



**AALBORG UNIVERSITY**  
DENMARK

**Aalborg Universitet**

## **Lyapunov Based-Distributed Fuzzy-Sliding Mode Control for Building Integrated-DC Microgrid with Plug-in Electric Vehicle**

Ghiasi, Mohammad Iman; Aliakbar Golkar, Masoud ; Hajizadeh, Amin

*Published in:*  
IEEE Access

*DOI (link to publication from Publisher):*  
[10.1109/ACCESS.2017.2689807](https://doi.org/10.1109/ACCESS.2017.2689807)

*Publication date:*  
2017

*Document Version*  
Publisher's PDF, also known as Version of record

[Link to publication from Aalborg University](#)

*Citation for published version (APA):*

Ghiasi, M. I., Aliakbar Golkar, M., & Hajizadeh, A. (2017). Lyapunov Based-Distributed Fuzzy-Sliding Mode Control for Building Integrated-DC Microgrid with Plug-in Electric Vehicle. *IEEE Access*, 5, 7746 - 7752. <https://doi.org/10.1109/ACCESS.2017.2689807>

### **General rights**

Copyright and moral rights for the publications made accessible in the public portal are retained by the authors and/or other copyright owners and it is a condition of accessing publications that users recognise and abide by the legal requirements associated with these rights.

- ? Users may download and print one copy of any publication from the public portal for the purpose of private study or research.
- ? You may not further distribute the material or use it for any profit-making activity or commercial gain
- ? You may freely distribute the URL identifying the publication in the public portal ?

### **Take down policy**

If you believe that this document breaches copyright please contact us at [vbn@aub.aau.dk](mailto:vbn@aub.aau.dk) providing details, and we will remove access to the work immediately and investigate your claim.

Received November 24, 2016, accepted December 14, 2016, date of publication April 19, 2017, date of current version June 7, 2017.

Digital Object Identifier 10.1109/ACCESS.2017.2689807

# Lyapunov Based-Distributed Fuzzy-Sliding Mode Control for Building Integrated-DC Microgrid With Plug-In Electric Vehicle

MOHAMMAD IMAN GHIASI<sup>1</sup>, MASOUD ALIAKBAR GOLKAR<sup>2</sup>,  
AND AMIN HAJIZADEH<sup>3</sup>, (Senior Member, IEEE)

<sup>1</sup>Department of Power Electrical Engineering, Science and Research Branch, Islamic Azad University, Tehran 1477893855, Iran

<sup>2</sup>Department of Power Electrical Engineering, K. N. Toosi University of Technology, Tehran 19697 64499, Iran

<sup>3</sup>Department of Energy Technology, Aalborg University, 6700 Aalborg, Denmark

Corresponding author: Masoud Aliakbar Golkar (masodgolkar@gmail.com)

**ABSTRACT** This paper presents a distributed control strategy based on fuzzy-sliding mode control (FSMC) for power control of an infrastructure integrated with a dc-microgrid, which includes photovoltaic, fuel cell, and energy storage systems with plug-in electric vehicles (PEVs). In order to implement the proposed control strategy, first, a general nonlinear modeling of a dc-microgrid based on related dc-dc converters to each dc power sources is introduced. Second, a power management strategy based on fuzzy control for regulating the power flow between the hybrid dc sources, PEVs is proposed. Third, to retain the balance between the requested power and the output power, adaptive FSMC strategy, for controlling the battery energy storage and fuel cell, is suggested. Finally, experimental results are presented to validate the potential of the proposed power flow control strategy.

**INDEX TERMS** DC-microgrid, power control, renewable energy, plug-in electric vehicle, fuzzy control, sliding mode control, renewable energy sources.

## I. INTRODUCTION

Interconnection of distributed power sources and energy storages has enabled the prospect of micro grids, both in ac as well as dc forms [1], [2]. Recently, infrastructure integrated-dc power sources have been getting more attention. This is due to higher implementation of dc energy storage systems, plug-in electric vehicles and dc renewable energy sources for residential and commercial applications. Furthermore, with considering of the global environmental sustainability and energy security all around the world, this should therefore come as a no surprise. As a result, the development of the smart grid technologies and implementation of dc microgrid, is becoming highly attractive as well as practical in the construction industry. In addition to that, the smart homes and the buildings are generally considered to have a proper combination of overall comfort, energy consumption and sustainability by utilizing intelligent as well as sustainable technologies. The dc connection of renewable energy sources offers greater controllability. It eliminates the need for synchronization and reactive power compensation, which are required for the ac installations [3], [4]. Furthermore, the dc interconnection is decoupled fully from the utility grid with

the use of power electronic converters. This enables a smooth transition between off and on grid-connected modes.

According to the published literature, it is evident that the integration of renewable energy sources with plug-in electric vehicles while also supplying power to the residential-complex is a complicated issue, which needs to be carefully addressed. In the published literature, from a power management point of view, different power controls have been studied to enhance the power flow [5], [6], fuzzy control [7]–[9], and predictive optimization [10]–[12]. The fuzzy controllers have been designed based on constant rules base and due to load change, it has not adaptive property. Moreover, the predictive control methods need more mathematical and complex implementation and could not be used for real time applications.

Furthermore, the proposed controllers are almost linear, while neither the stability analysis nor the robustness of the control structures have been examined, either during load power changing or during the charging and discharging of pev. Additionally, an experimental setup for the implementation of dc microgrid in an infrastructure application has also not been presented yet. Hence, in order to miti-

gate the power intermittency and the uncertainty of renewable resources, while also delivering a stable and reliable power supply for both, the utility and the local customers, it is imperative to design an advanced power control strategy for the infrastructure integrated-hybrid dc power sources with versatile loads.

In this paper, a fuzzy control structure for accommodation integrated hybrid power resources and plug-in electric vehicles (pevs) is developed for managing power between infrastructure, power sources (photovoltaic, fuel cell) and pevs. In order to build the hybrid power source combined with plug-in electric vehicles for the green buildings, the mathematical models of photovoltaic, fuel cell, battery and power converters are implemented in matlab/simulink environment. Furthermore, an adaptive fuzzy sliding power control strategy for dc-dc converter (which is connected to the battery energy storage system), is proposed to keep the power balance in the dc-link. In order to validate the response of power controller to achieve the energy balance characteristic, an experimental setup has been created. Finally, experimental analyses for different case studies are presented. If your paper is intended for a conference, please contact your conference editor concerning acceptable word processor formats for your particular conference.

## A. ABBREVIATIONS AND ACRONYMS

### Fuel Cell

r <sub>FC</sub>	fuel cell internal resistance[ $\Omega$ ];
v <sub>FC</sub>	fuel cell voltage [V];
i <sub>FC</sub>	fuel cell current [A];

### Battery

SOC	battery state of charge;
r <sub>Batt</sub>	battery internal resistance[ $\Omega$ ];
v <sub>Batt</sub>	battery voltage [V];
i <sub>Batt</sub>	battery current [A];

### Photovoltaic

r <sub>PV</sub>	photovoltaic internal resistance[ $\Omega$ ];
v <sub>PV</sub>	photovoltaic voltage [V];
i <sub>PV</sub>	photovoltaic current [A];

### DC/DC Converter

d <sub>FC</sub>	duty cycle of fuel cell DC-DC converter;
L <sub>FC</sub>	input inductor of fuel cell DC-DC converter [H];
d <sub>Batt</sub>	duty cycle of battery DC-DC converter;
L <sub>Batt</sub>	input inductor of battery DC-DC converter [H];
d <sub>PV</sub>	duty cycle of photovoltaic DC-DC converter;
L <sub>PV</sub>	input inductor of photovoltaic DC-DC converter [H];
C <sub>dc</sub>	DC-link capacitor [F];

### DC/AC Converter

L <sub>f</sub>	output filter inductor of DC-AC converter [H];
C <sub>f</sub>	output filter capacitor of DC-DC converter [F];

## Control Parameters

P <sub>demand</sub>	active power demand [Watt];
P <sub>FC</sub>	fuel cell power [Watt];
P <sub>batt</sub>	battery Power [Watt];
P <sub>EV</sub>	electric vehicle Power [Watt];
P <sub>PV</sub>	photovoltaic Power [Watt];
Q <sub>demand</sub>	reactive power demand [VAr];
i <sub>load</sub>	load current [A];
X(t)	state vector;
u(t)	input vector;
w(t)	input disturbance;
s	sliding surface;
m	rules number of fuzzy controller;
C <sub>j</sub>	consequent parameter of fuzzy controller;
$\mu_j$	weighting factor of fuzzy controller;
$\eta$	adaptive rate parameter;

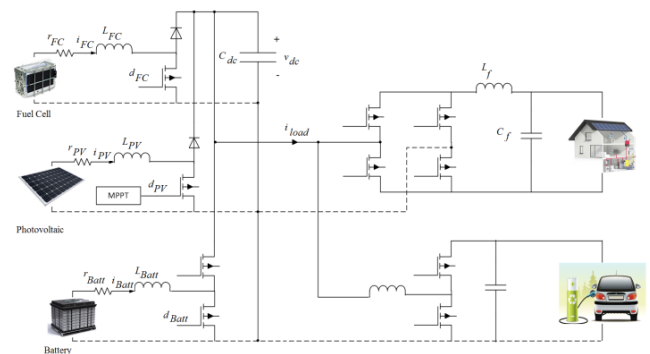

FIGURE 1. Configuration of Hybrid DC microgrid combined with Plug-in Electric Vehicle.

## II. PROPOSED SYSTEM FRAMEWORK DESCRIPTION

As the Figure 1 illustrates, the overall hybrid power system is composed of load, the power generation resources, energy storage and the PEV. In this paper, the power generation resources include photovoltaic and fuel cell, which are green technologies with zero CO<sub>2</sub> emission. The PEV system should be considered as a new form of distributed storage. It is combined with the other power sources and the controllable loads of the smart home. The detailed mathematical models of fuel cell, photovoltaic, battery system and power converters are available in literatures [9]–[12].

## III. POWER CONTROL STRATEGY

Power control strategy is required to keep power balance at all times between hybrid power sources, PEV, smart building and the power to/from the grid. This has to be done while satisfying the active and reactive power demanded by the home electrical load. In addition, to satisfy the power required by the load, it is important to consider the physical limitations of fuel cell and uncontrollable characteristics of photovoltaic power. Hence, in this part, the controller designs for the fuel cell and the energy storage are as follows.

**A. CONTROL OF FUEL CELL POWER SOURCE**

In the proposed power generation system, the fuel cell plays an important role. It has high reliability than other renewable energy sources. However, on the other hand, it has some physical and dynamical constraints that needs be taken into account for the control structure of the fuel cell. In this paper, a fuzzy control strategy is proposed for the fuel cell. In fact, it is a modified structure of controller, which has been published in [13]. The block diagram is shown in Figure 2 and the PEV and PV output powers are also contributing in determining the fuel cell output power. To obtain the output of the controller, the degrees of membership of the if-parts of all rules which they are shown in Figure 2, are evaluated. Finally, the then-parts of all rules are weighted and averaged by these degrees of membership. The core of the rule set for the fuzzy controller is illustrated in Table 1.

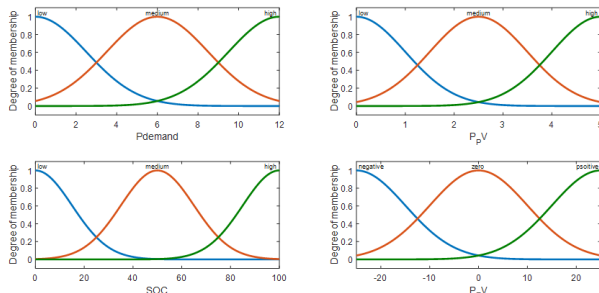
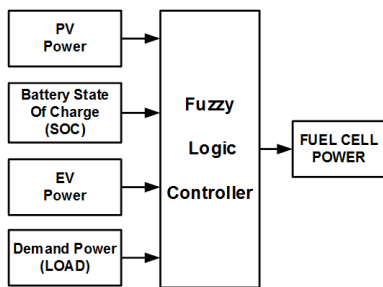

**FIGURE 2. Block diagram of Fuzzy Control Strategy and membership functions.**

**B. ADAPTIVE FUZZY SLIDING MODE CONTROL OF DC-DC CONVERTERS CONNECTED TO BATTERY ENERGY STORAGE AND FUEL CELL**

Due to slow variation in the fuel cell power, the energy storage is utilized to regulate the power in the DC-link. The batteries are connected to the DC-link through a bidirectional DC-DC converter. Two important objectives must be fulfilled by proper control of the DC-DC converter, i.e., regulation of battery voltage and providing the requested power from the battery system. For this purpose, the equation (1) is extracted according to Figure.1.

By rearranging the equation (2), the standard state space equation (2) is achieved:

$$L_{Batt} \frac{di_{Batt}}{dt} = d_{Batt}v_{Batt} - (1 - d_{Batt})v_{dc} - r_{Batt}i_{Batt}$$

**TABLE 1. The rule base of fuzzy power controller.**

Inputs of Fuzzy Controller				Output
P <sub>demand</sub>	SOC	P <sub>PV</sub>	P <sub>EV</sub>	P <sub>FC</sub>
low	low	low	negative	medium
medium	low	low	negative	high
medium	high	medium	positive	medium
medium	high	high	positive	low
high	high	low	Positive	medium
high	high	high	positive	low
high	low	low	positive	high
low	low	zero	positive	low
medium	low	zero	positive	medium
high	low	zero	positive	medium
medium	low	zero	negative	high
high	low	zero	negative	high
low	low	zero	negative	medium

$$C_{dc} \frac{dv_{dc}}{dt} = (1 - d_{Batt})i_{Batt} - i_{load}$$

$$L_{FC} \frac{di_{FC}}{dt} = d_{FC}v_{FC} - (1 - d_{FC})v_{dc} - r_{FC}i_{FC} \quad (1)$$

$$\dot{X}(t) = f(X(t)) + g(X(t))u(t) + w(t)$$

$$f(X(t)) = \begin{bmatrix} \frac{(v_{dc} + r_{Batt}i_{Batt})}{L_{Batt}i_{Batt}} \\ \frac{C_{dc}}{v_{dc} + r_{FC}i_{FC}} \\ \frac{L_{FC}}{L_{FC}} \end{bmatrix},$$

$$g(X(t)) = \begin{bmatrix} \frac{v_{dc} + v_{Batt}}{L_{Batt}i_{Batt}} \\ -\frac{C_{dc}}{v_{dc} + r_{FC}i_{FC}} \\ \frac{L_{FC}}{L_{FC}} \end{bmatrix}, \quad X(t) = \begin{bmatrix} i_{Batt} \\ v_{dc} \\ i_{FC} \end{bmatrix}$$

$$u = \begin{bmatrix} d_{Batt} \\ d_{FC} \end{bmatrix}, \quad w(t) = i_{load} \quad (2)$$

Therefore, in the above equations, f is the system matrix, g is the input matrix, X(t) is the state vector, u(t) is the input vector and w(t) is the input disturbance. From, the equation, it is clear that all matrixes and inputs are related to the system parameters. As shown, the control input is the duty cycle of DC-DC converters ( $d_{batt}$ ,  $d_{FC}$ ) and the input disturbance is the load current ( $i_{load}$ ) which includes the requested current from the house and the PEV charging/discharging current.

Inherently, the equation (4) is nonlinear and time varying. The input disturbance (loads) is unpredictable and it has stochastic nature because of charging and discharging period of PEV. Due to the mentioned properties, inaccurate mathematical models, unknown parameters and the need for a fast response during the transient power, the linear conventional controller cannot be utilized for stabilizing the DC-link power. Hence, in this paper an adaptive fuzzy sliding mode control [15] is proposed for controlling the DC-DC converter. By incorporating linguistic information from human experts, the fuzzy control can provide a good solution to these issues. Therefore, it, as an alternative to conventional control techniques, is gaining increased interest among both, the academic world as well as the industry. Despite its practical successes in many areas, fuzzy control seems to be deficient in formal analysis and robustness aspects. On the other hand, the sliding-mode control has been extensively used to control non-linear dynamic systems, mostly the systems that have uncertainty in model and disturbance. In the continuing pages, the details of adaptive fuzzy sliding mode control are introduced. In order to describe the sliding surface, following two functions are considered:

$$e = \begin{bmatrix} e_1 \\ e_2 \\ e_3 \end{bmatrix} = \begin{bmatrix} i_{Batt-ref} - i_{Batt} \\ v_{dc-ref} - v_{dc} \\ i_{FC-ref} - i_{FC} \end{bmatrix} \quad (3)$$

Where  $e$  is the phase plane variable.

Then based on the phase plane in (3), the sliding surface can be defined as [15]:

$$s = \left( \frac{d}{dt} + l \right) e = \frac{d}{dt} \begin{bmatrix} e_1 \\ e_2 \\ e_3 \end{bmatrix} + \lambda \begin{bmatrix} e_1 \\ e_2 \\ e_3 \end{bmatrix} \quad (4)$$

According to this criterion for sliding surface, the requested current (power) produced or absorbed by battery, the requested current from the fuel cell and the DC-link voltage are regulated. The control signals (dBatt, dFC) are fed to the pulse width modulator (PWM). In order to eliminate the chattering effect of sliding mode control on the control signals, a fuzzy control is used in order to form a fuzzy sliding mode control (FSMC) structure. In this structure,  $s$  and  $ds/dt$  are considered as inputs for fuzzy controller. Moreover, an adaptive law is implemented on difuzzification part to achieve the adaptive control structure. For implementing the adaptive FSMC, the output of fuzzy controllers is considered as follow:

$$u_{Fuzzy} = \frac{\sum_l \mu^j \cdot U^j}{\sum_l \mu^j} = \frac{\sum_l \mu^j \cdot C^j}{\sum_l \mu^j} \quad (5)$$

Then, the gradient-descent method is used for adjusting the parameter  $C_j$ :

$$C_{k+1}^j = C_k^j - \eta \frac{\partial S_k}{\partial C_k^j} \quad (6)$$

The symbol  $\eta$  is the learning rate parameter, and  $k$  indicates the number of learning iterations executed by the algorithm. In order to meet the stability of learning algorithm, the Lyapunov function based on sliding surface is considered, which is as follow [16]:

$$\begin{aligned} V_k &= \frac{1}{2} S_k^2 \\ \Delta V_k &= V_{k+1} - V_k = \frac{1}{2} (S_{k+1}^2 - S_k^2) \\ &= \frac{1}{2} (S_{k+1} - S_k)(S_{k+1} + S_k) \end{aligned} \quad (7)$$

From equation (9), the following equations are extracted:

$$\begin{aligned} \Delta S_k &= S_{k+1} - S_k = \frac{\partial S_k}{\partial C_k^j} \Delta C_k^j \\ \Delta C_k^j &= C_{k+1}^j - C_k^j = \eta \frac{\partial S_k}{\partial C_k^j} \end{aligned} \quad (8)$$

After replacing the equations (7) and (8), it is re-written:

$$\begin{aligned} \Delta V_k &= \frac{1}{2} (S_{k+1} - S_k)(S_{k+1} + S_k) = \frac{1}{2} (\Delta S_k) \cdot (S_{k+1} + S_k) \\ &= \frac{1}{2} (\Delta S_k) (2S_k + \Delta S_k) \\ &= \frac{1}{2} \frac{\partial S_k}{\partial C_k^j} \eta S_k \frac{\partial S_k}{\partial C_k^j} (-2S_k + \frac{\partial S_k}{\partial C_k^j} \eta S_k \frac{\partial S_k}{\partial C_k^j}) \\ &= \frac{1}{2} (S_k \frac{\partial S_k}{\partial C_k^j})^2 \left[ \left( \frac{\partial S_k}{\partial C_k^j} \right)^2 \eta^2 - 2\eta \right] \end{aligned} \quad (9)$$

Finally, in order to reach the Lyapunov stability, the following conditions need to be satisfied:

$$\Delta V_k < 0 \rightarrow \left( \frac{\partial S_k}{\partial C_k^j} \right)^2 \eta^2 - 2\eta < 0 \quad (10)$$

$$0 < \eta < \frac{2}{\left( \frac{\partial S_k}{\partial C_k^j} \right)^2} \quad (11)$$

#### IV. EXPERIMENTAL RESULTS AND STABILITY ANALYSIS OF PROPOSED CONTROLLER

For a residential building with solar panels, fuel cell and energy storage; the impact of PEV charging on the performance of proposed fuzzy controller, will depend on the capacity of the PEV battery, PV, fuel cell and energy storage. The battery pack in the building can be utilized to partially or fully charge the PEV battery to reduce the peak load. In order to implement the power control strategy, a laboratory scale of zero energy building has been created in the laboratory. A 13kWh 45Ah lithium-ion battery from SAFT is used for energy storage. Moreover, 15 kW PEMFC from BALARD is used as a main power source. Two 10kW DC electronic loads from Chroma are applied to emulate the house appliances. The specification of the PV system, the Li-Ion battery, PEMFC stack and the power electronic converter 'parameters including DC-DC and DC-AC converters are given



in [13] and [14]. The operation of the proposed PV/PEMFC/battery hybrid system model was examined under different operating, charging and discharging conditions of the PEV and simulation results are obtained for the time interval between 0 and 350 s. The power demand profile has a noteworthy effect on the performance of proposed control strategy. A practical load profile for a family of two, is measured for the resident application, as shown in Figure 3 (a). In order to simulate the PV model, the output power of an actual solar power system is used for a short time interval, which is shown in Figure 3(b). The output power of DC-DC converter is the maximum power of PV for each sampling time. It is observable from this load profile that the average power demand is 6 kW. However, because of the weather conditions, the output power of the PV system deviates from 5 to 7 kW. For this purpose, an experiment based on the requested load power and output power of solar panel (Figure 3) is performed. In Figure 4, power flow between fuel cell, energy storage, grid and photovoltaic is illustrated. As shown, all power resources with grid participate to supply load power. According to proposed fuzzy control strategy, the fuel cell power is generated smoothly; while the batteries and the photovoltaic can meet all the rest of load power concurrently. In order to evaluate the performance of proposed control strategies, the output power of PV is going towards zero for 50 seconds, between 150sec until 200 sec. In this case, the fuel cell, the batteries and the grid supply the power for load at the same time. Another case for study is the integration of PEV at time 100 sec. For this purpose, the PEV is connected with the DC-link in order to charge the batteries around to 4.5kW. At time 275 sec, the PEV is disconnected and according to the load power and PV power conditions, the fuel cell power decreases. The obtained results prove that the proposed control strategy could keep the power balance in this system and during power changes for each component, the robustness and stability is satisfied. In fact, during charging operation mode, the battery energy storage system is used to manage the power of the building. Thus, it can keep the balance between requested power from building and produced power from fuel cell and PV. Moreover, during the charging mode of PEV, the energy storage plays an important role in delivering enough power to PEV. As shown, after disconnecting the PEV, the battery switches to the charge operation mode for storing the extra power produced by the PV. In order to show the capability of proposed controller, battery's SOC and DC-link voltage are shown in Figure 5. The battery's SOC can be maintained at a reasonable level as seen in Figure 5 (a). From Figure 5 (b), it can be observed that the DC-link voltage control has been satisfied correctly and that it is nearly constant during integration of PEV, load and solar output power variations. Moreover, the chattering in the DC-link voltage due to implementation of fuzzy and sliding mode control has been reduced. Furthermore, the current and the voltage of the fuel cell is presented in Figure 6. The tracking capability of the fuel cell current controller

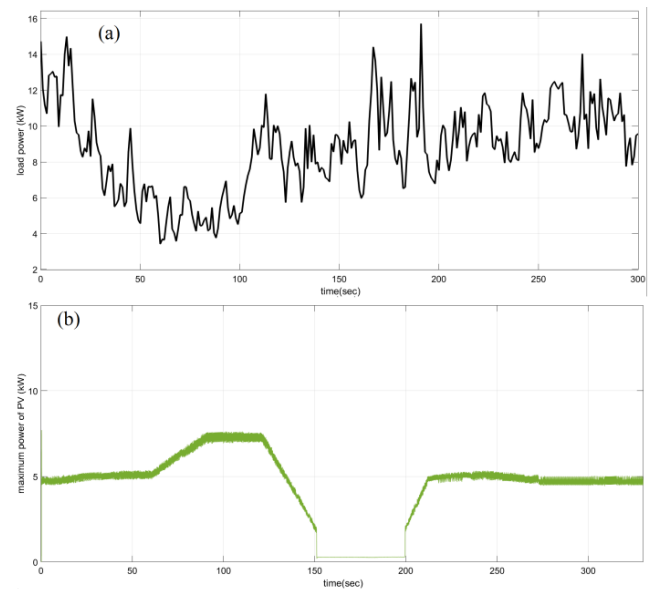

**FIGURE 3.** Load active power (a) and output power of solar panel (b) for resident application.

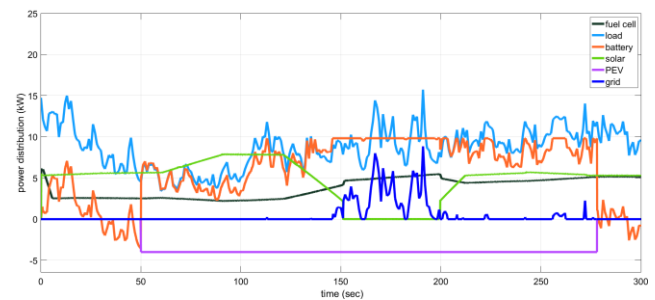

**FIGURE 4.** Power distribution between fuel cell, photovoltaic, load, grid and battery energy storage during charging of electric vehicle.

is illustrated in Figure 6 (a). It shows that the response of controller is very fast and it could track the reference values without any overshoot and very precisely. In Figure 6 (b), variation of the fuel cell voltage during changing fuel cell current has been demonstrated. As presented, the fuel cell operates in the linear region of operational characteristics, which satisfies the stability of the fuel cell during any change. Finally, the dynamic behavior of the proposed controller is investigated under vehicle-to-building charge injection. In this case, it is supposed that the PEV is connected to building to deliver part of power. Hence, the PEV is integrated with the building during the on-peak interval. Therefore, the PEV is connected to DC-link at time 60 sec. In Figure 7, the power distribution for each power resources and load power is shown. According to Figure 7, when the PEV is connected in the discharging period, the battery energy storage of building with PEV's battery, supply the load power during the on-peak interval concurrently. As observed from power distribution profile, the fuel cell power stays constant.

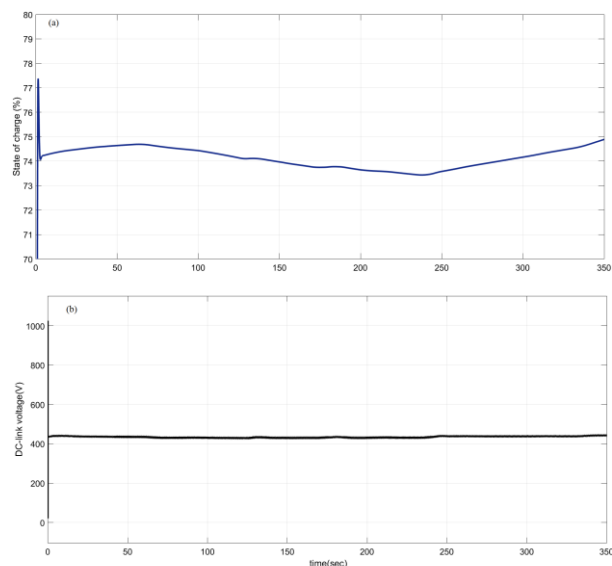

FIGURE 5. Battery's SOC (a) and DC-link voltage (b).

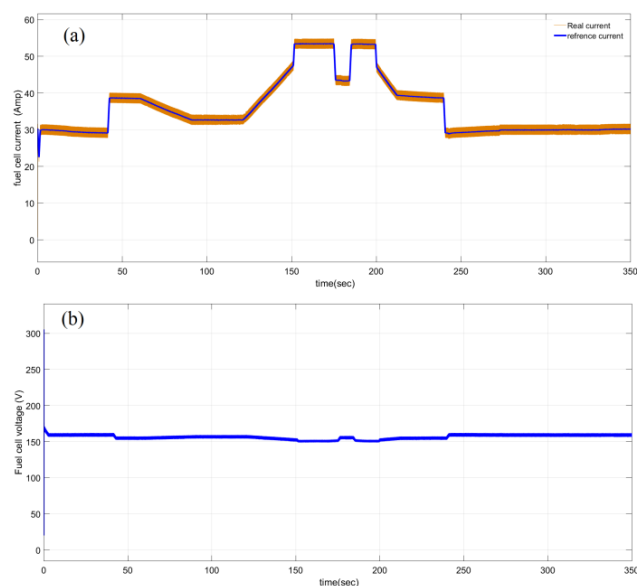

FIGURE 6. Fuel cell current and voltage.

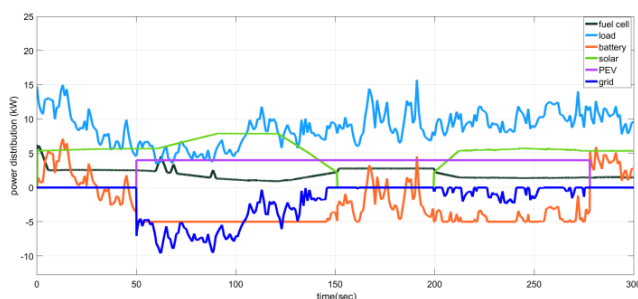

FIGURE 7. Power distribution between fuel cell, photovoltaic and battery energy storage during dis-charging of electric vehicle.

## V. CONCLUSION

In this paper, a power flow control of infrastructure-integrated hybrid power sources with plug-in electric vehicles in a smart

distribution system is scrutinized. The controllers design methodology for power converters is introduced in order to regulate the power flow from the power generation system to the load. Adaptive fuzzy sliding mode controllers have been designed for both fuel cell and battery's DC-DC converters to stabilize the DC-link voltage and track the reference currents of these power sources. Experimental results are illustrated to exemplify the effectiveness and the potential of the proposed control strategy during different load conditions, irradiance and states of charging and discharging of PEV.

## REFERENCES

- [1] H. Kakigano, Y. Miura, and T. Ise, "Configuration and control of a DC microgrid for residential houses," in *Proc. Asia-Pacific Transmiss. Distrib. Conf. Expo.*, Oct. 2009, pp. 1–4.
- [2] J. Khajepour, K. Sheshyekani, M. Hamzeh, and E. Afjei, "High-performance hybrid photovoltaic-battery system based on quasi-Z-source inverter: Application in microgrids," *IET Gener. Transm. Distrib.*, vol. 9, no. 10, pp. 895–902, 2015.
- [3] P. T. Baboli, M. Shahparasti, M. P. Moghaddam, M. R. Haghifam, and M. Mohamadian, "Energy management and operation modeling of hybrid AC-DC microgrid," *IET Gener. Transm. Distrib.*, vol. 8, no. 10, pp. 1700–1711, 2014.
- [4] M. Sechilariu, B. Wang, and F. Locment, "Building-integrated microgrid: Advanced local energy management for forthcoming smart power grid communication," *Energy Buildings*, vol. 59, pp. 236–243, Apr. 2013.
- [5] Z. Wang, L. Wang, A. Dounis, and R. Yang, "Integration of plug-in hybrid electric vehicles into energy and comfort management for smart building," *Energy Buildings*, vol. 47, pp. 260–266, Apr. 2012.
- [6] Z. Wang, R. Yang, and L. F. Wang, "Multi-agent intelligent controller design for smart and sustainable buildings," in *Proc. IEEE Syst. Conf.*, San Diego, CA, USA, Apr. 2010, pp. 277–282.
- [7] Y.-K. Chen, Y.-C. Wu, C.-C. Song, and Y.-S. Chen, "Design and implementation of energy management system with fuzzy control for DC microgrid systems," *IEEE Trans. Power Electron.*, vol. 28, no. 4, pp. 1563–1570, Apr. 2013.
- [8] V. Courtecuisse, J. Sprooten, B. Robyns, M. Petit, B. Francois, and J. Deuse, "A methodology to design a fuzzy logic based supervision of hybrid renewable energy systems," *Math. Comput. Simul.*, vol. 81, no. 2, pp. 208–224, 2010.
- [9] A. Dounis, P. Tiropanis, A. Argiriou, and A. Diamantis, "Intelligent control system for reconciliation of the energy savings with comfort in buildings using soft computing techniques," *Energy Buildings*, vol. 43, no. 1, pp. 66–74, Jan. 2011.
- [10] R. Negenborn, M. Houwing, J. D. Schutter, and J. Hellendoorn, "Model predictive control for residential energy resources using a mixed-logical dynamic model," in *Proc. IEEE Int. Conf. Netw., Sens. Control (ICNSC)*, Okayama, Japan, Mar. 2009, pp. 702–707.
- [11] B. Mayera, M. Killianb, and M. Kozek, "Management of hybrid energy supply systems in buildings using mixed-integer model predictive control," *Energy Convers. Manage.*, vol. 98, no. 1, pp. 470–483, 2015.
- [12] H. Huang, L. Chen, and E. Hu, "A new model predictive control scheme for energy and cost savings in commercial buildings: An airport terminal building case study," *Building Environ.*, vol. 89, pp. 203–216, Jul. 2015.
- [13] A. Hajizadeh and M. A. Golkar, "Control of Hybrid Fuel Cell/Energy Storage Distributed Generation System against Voltage Sag," *Int. J. Elect. Power Energy Syst.*, vol. 32, pp. 488–497, Jun. 2010.
- [14] A.-A. Bayod-Rújula and J.-A. Cebollero-Abian, "A novel MPPT method for PV systems with irradiance measurement," *Solar Energy*, vol. 109, pp. 95–104, Nov. 2014.
- [15] R.-J. Wai, "Fuzzy sliding-mode control using adaptive tuning technique," *IEEE Trans. Ind. Electron.*, vol. 54, no. 1, pp. 586–594, Feb. 2007.
- [16] C. T. Chen, *Linear System Theory and Design*. Oxford, U.K.: Oxford Univ. Press, 1995.



**MOHAMMAD IMAN GHIASI** was born in Tehran, Iran, in 1982. He received the B.Sc. and M.Sc. degrees in electrical engineering (power systems) from the K.N.T. University of Technology, Tehran, in 2004 and 2006, respectively. He is currently pursuing the Ph.D. degree in electrical engineering (power systems) with the Department of Power Electrical Engineering, Science and Research Tehran branch, Islamic Azad University. Since 1979, he has been involved in teaching and research with Islamic Azad University and Research Institute of Petroleum Industry. His research interests include distributed generation studies, smart grid, reactive power studies, loss calculations, and zero energy home studies. He is currently the advisor of the NIOC Electricity Board, the NISOC Electricity Board, and IFCO in the field of distribution systems.



**MASOUD ALIAKBAR GOLKAR** was born in Tehran, Iran, in 1954. He received the B.Sc. degree from the Sharif University of Technology, Tehran, in 1977, the M.Sc. degree from the Oklahoma State University, USA, in 1979, and the Ph.D. degree from the Imperial College of Science, Technology, and Medicine, The University of London, U.K., in 1986, all in electrical engineering (power systems). He was a part time Head of the Research Group for Distribution studies with the Electric Power Research Center for over ten years. From 2002 to 2005, he served as a Senior Lecturer with the Curtin University of Technology, Malaysia. Since 1979, he has been involved in teaching and research with K N Toosi University of Technology. His research interests include distributed generation studies, smart grid, reactive power studies, loss calculations, and reduction in distribution systems, power system studies, distribution system optimization and automation, voltage collapse studies, distribution systems study by probabilistic methods, renewable energy studies, and load and energy management. He is currently the Advisor of the Tehran Electricity Board, the Shiraz Electricity Board, and the Bandar Abbas Electricity Board in the field of distribution systems.



**AMIN HAJIZADEH** (S'03–M'10–SM'15) received the B.Sc. degree from the Ferdowsi University of Mashhad, Iran, in 2002, and the M.Sc. and Ph.D. degrees from the K.N.Toosi University of technology Tehran, Iran, in 2005 and 2010, all in electrical engineering. In 2009, he was a Visiting Ph.D. Student with the Department of Electrical Power Engineering, Norwegian University of Science and Technology, Trondheim, Norway. He was an Assistant Professor with the Shahrood University of Technology, Shahrood, Iran, from 2010 to 2014. He held a post-doctoral position with the Norwegian University of Science and Technology, Trondheim, Norway, from 2015 to 2016. Since 2016, he has been an Associate Professor with the Department of Energy Technology, Aalborg University. His current research interests include control of distributed energy resources, design and control of power electronic converters for microgrid, and marine power systems.

• • •