



1985

## Electrophysiologic Study of the Effect of phospholipase-C (Clostridium welchii-type) on Neuromuscular Transmission in the Mouse

Lukasz M. Konopka-Egan  
*Loyola University Chicago*

Follow this and additional works at: [https://ecommons.luc.edu/luc\\_diss](https://ecommons.luc.edu/luc_diss)

 Part of the [Medicine and Health Sciences Commons](#)

---

### Recommended Citation

Konopka-Egan, Lukasz M., "Electrophysiologic Study of the Effect of phospholipase-C (Clostridium welchii-type) on Neuromuscular Transmission in the Mouse" (1985). *Dissertations*. 2349.  
[https://ecommons.luc.edu/luc\\_diss/2349](https://ecommons.luc.edu/luc_diss/2349)

This Dissertation is brought to you for free and open access by the Theses and Dissertations at Loyola eCommons. It has been accepted for inclusion in Dissertations by an authorized administrator of Loyola eCommons. For more information, please contact [ecommons@luc.edu](mailto:ecommons@luc.edu).



This work is licensed under a [Creative Commons Attribution-NonCommercial-No Derivative Works 3.0 License](#).  
Copyright © 1985 Lukasz M. Konopka-Egan

ELECTROPHYSIOLOGIC STUDY OF THE EFFECT OF PHOSPHOLIPASE-C  
(CLOSTRIDIUM WELCHII-TYPE) ON NEUROMUSCULAR TRANSMISSION  
IN THE MOUSE

by

Lukasz M. Konopka-Egan

A Dissertation Submitted to the  
Faculty of the Graduate School  
Loyola University of Chicago in Partial Fulfillment  
of the Requirements for the Degree of  
Doctor of Philosophy  
October  
1985

**LOYOLA UNIVERSITY MEDICAL CENTER LIBRARY**

## ACKNOWLEDGMENTS

This dissertation is the culmination of a long struggle to learn and produce. This process would not have been possible without the dedication and support of many people. I would like to thank Professor A.G. Karczmar for allowing this experience to be conceived and executed, for he altered his plans to accommodate "one last student". In the early stages of my work, his guidance and support were invaluable in leading me towards a workable problem. In the latter stages of my work, his constructive criticism and deep scientific insight gave me direction and inspiration. I would like to thank Robert Carperter for his dedicated help in designing the set-up for the electronic hardware as well as for writing all of the on-line data-acquisition and analysis programs. I would like to thank the members of my committee for their critical input, especially Drs. Dun and Friedman, who readily shared their respective expertise and laboratory space. This work would not have been possible without the support of the secretaries, especially Mary Ann Jurgus, who facilitated the purchasing of equipment and allowed me the use of her word processing unit. Last, but not least, I would like to thank my wife, Mary, for her patience and love. Mary, in her unselfishness, was instrumental in the preparation of this dissertation, from editing, to typing, to the drawing of the schematics.

## VITA

The author, Lukasz Maciej Konopka-Egan, is the son of Wojciech and Regina (Kieda) Konopka. He was born in Poland on August 7, 1953, and immigrated to the U.S. in 1969.

He graduated from Gordon Technical High School in 1972 and from the University of Illinois in 1977. He received his Master of Arts degree from the University of Chicago in 1981. He began his graduate education at Loyola University of Chicago, Stritch School of Medicine in the Department of Pharmacology in July of 1980. In 1981, he was married to Mary D. Young.

As of January 1, 1986, the author will assume a post-doctoral fellowship in the laboratory of Prof. Rodney Parsons in the department of Anatomy and Neurobiology at the University of Vermont, College of Medicine.

While a graduate student at Loyola, the author was awarded a Loyola University of Chicago Basic Science Fellowship (1980-1985).

The author has been a member of the American Association for the Advancement of Science since 1983 and a member of the Chicago Area Evoked Potential Society since 1983.

## LIST OF TABLES

TABLE 0:	Composition of Ionically Varied Ringer Solutions..	56
TABLE 1:	mEPP Amplitudes and Frequencies.....	131
TABLE 2:	EPP Amplitudes and Waveform Analysis in Normal Ringer.....	138
TABLE 3:	EPP Amplitudes and Waveform Analysis in low Ca <sup>++</sup> /high Mg <sup>++</sup> .....	142
TABLE 4:	ACh Potential Amplitudes: Bath Applied and Microejected.....	149
TABLE 5:	Microejected Carbachol Potential Amplitudes and Waveform Analysis.....	160
TABLE 6:	Quantal Content Measurements Calculated by Two Methods.....	168
TABLE 7:	Amplitudes of the Electrotonic Potential and Membrane Resistance.....	173
TABLE 8:	Amplitudes and Waveform Analysis of EPCs.....	181

## LIST OF FIGURES

FIGURE 0: Phospholipases Action upon a Phospholipid.....	26
FIGURE 1: Compound Action Potential in dTc and TTX.....	118
FIGURE 2: PLC Effect on the Compound Action Potential in the Cut-muscle Preparation.....	120
FIGURE 3: PLC Effect on the Compound Action Potential in dTc Half-block.....	122
FIGURE 4: PLC Effect on the Compound Action Potential in the low Ca <sup>++</sup> /high Mg <sup>++</sup> Solution.....	124
FIGURE 5: The Effects of Differing Concentrations of PLC on the RMP.....	127
FIGURE 6: A mEPP Experiment.....	133
FIGURE 7: An mEPP Experiment Showing a Biphasic Effect.....	135
FIGURE 8: An EPP Experiment in dTc Half-block Solution.....	140
FIGURE 9: An EPP Experiment in low Ca <sup>++</sup> /high Mg <sup>++</sup> Solution.....	146
FIGURE 10: Bath-applied ACh Potential Experiment.....	152
FIGURE 11: Microejection ACh Potential Experiment.....	154
FIGURE 12: Microejected ACh Potential Waveforms.....	156
FIGURE 13: Microejected Carbachol Potential Experiment.....	162
FIGURE 14: Microejected Carbachol Potential Waveforms.....	164
FIGURE 15: Failure Method Quantal Content Experiment.....	170
FIGURE 16: Electrotonic Potential Experiment.....	175
FIGURE 17: Electrotonic Potential Waveforms.....	177

FIGURE 18: Voltage Clamp Experiment.....183  
FIGURE 19: Voltage Clamp Waveforms.....185  
FIGURE 20: Voltage Clamp Experiment without Washout.....188  
FIGURE 21: Voltage Clamp Waveforms from Experiment without  
Washout.....190

## LIST OF SCHEMATICS

SCHEMATIC 1:	Overall Recording Set-up.....	59
SCHEMATIC 2:	Data Acquisition Diagram.....	66
SCHEMATIC 3:	Compound Action Potential Set-up.....	79
SCHEMATIC 4:	RMP Set-up.....	83
SCHEMATIC 5:	mEPP Set-up.....	86
SCHEMATIC 6:	Bath-applied ACh Potential Set-up.....	89
SCHEMATIC 7:	Microejection ACh and Carbachol Potential Set-up.....	93
SCHEMATIC 8:	Quantal Content Recording Set-up.....	102
SCHEMATIC 9:	Electrotonic Potential Recording Set-up...	107
SCHEMATIC 10:	End-plate Current Recording Set-up.....	112



# TABLE OF CONTENTS

	Page
ACKNOWLEDGMENTS.....	ii
VITA.....	iii
LIST OF TABLES.....	iv
LIST OF FIGURES.....	v
LIST OF SCHEMATICS.....	vii
Chapter	
I. LITERATURE REVIEW.....	1
Anatomy of the neuromyal junction.....	1
Physiology of the neuromyal junction.....	5
Acetylcholine synthesis.....	6
Axonal action potential.....	8
Miniature endplate potential.....	13
Endplate potential.....	16
Endplate current.....	17
Pharmacology of the neuromyal junction.....	21
History of phospholipids.....	24
Action of Phospholipases.....	25
General Biochemistry of Phospholipases.....	29
Phospholipases A1 and A2.....	29
Phospholipase C.....	31
Phospholipase D.....	32

	The effects of phospholipases A1, A2, D & C on tissue models.....	34
	Ionic mechanisms involved in PLC activity.....	40
	Membrane lipids and proteins.....	43
	Membrane lipids and fluidity.....	43
	Proteins of the membrane.....	46
	Membrane fluidity and proteins.....	47
	Drugs and membrane fluidity.....	48
	Purpose.....	51
	Working hypothesis.....	52
	Experimental goals.....	52
II.	METHODS.....	55
	Animals used in experimentation.....	55
	Dissection of phrenic nerve-diaphragm.....	55
	Perfusion system and solutions.....	58
	Description of the overall schematic.....	58
	General description of the recording system.....	62
	Computerized data acquisition and analysis.....	65
	Description of acquisition programs.....	65
	Description of analysis programs.....	70
	Description of statistics.....	72
	General electrophysiologic methods.....	74
	Microelectrodes.....	74
	Localization of the end-plates.....	75
	Experimental paradigm.....	77
	Recording the compound action potential.....	81

	Recording the resting membrane potential.....	85
	Recording the miniature end-plate potential.....	85
	Recording the end-plate potential.....	88
	Recording the ACh potential.....	91
	Recording quantal content.....	96
	Recording the carbachol potential.....	105
	Recording the electrotonic potential.....	105
	Voltage clamp.....	109
III.	RESULTS.....	116
	Compound axonal action potential.....	116
	Resting membrane potential.....	126
	Miniature end-plate potential.....	129
	End-plate potential.....	144
	Acetylcholine potential.....	151
	Carbachol potential.....	159
	Quantal content.....	166
	Electrotonic potential.....	179
	Voltage clamp.....	179
	Summary of Results.....	192
IV.	DISCUSSION.....	194
	Compound axonal action potential.....	194
	Miniature end-plate potential.....	196
	Quantal content.....	199
	End-plate potential.....	204
	Acetylcholine potential.....	205

	Voltage clamp.....	207
	Electrotonic potential.....	211
V.	CONCLUSION.....	212
VI.	REFERENCES.....	214
VII.	APPENDIX I.....	235
VIII.	APPENDIX II.....	239
IX.	APPENDIX III.....	246
X.	APPENDIX IV.....	248

## LITERATURE REVIEW

### ANATOMY OF THE NEUROMYAL JUNCTION

The skeletal neuromuscular junction (NMJ) is defined as an area where a motorneuron abuts a muscle cell. Amphibian and mammalian NMJs are the subjects of the most extensive electrophysiological studies. The reason for their popularity is the anatomy of the junction which lends itself to investigation by microelectrode techniques. The two main components of the structure are: a) the axon with its terminal and b) the muscle with its post-synaptic receptor area. Gross light microscopic examination reveals a large, white cable-like structure (nerve fibers) which seems to melt into muscle cells characterized by a light red color and striations. The contact area of an individual axon with a muscle cell will appear to be more dense than the surrounding areas. This dense area is the junctional region, a structure characteristic of chemical synapses. It reveals its complexity only under electronmicroscopic investigation.

Upon such investigations, three distinct regions become apparent, the terminal, the cleft and the post-synaptic membrane. Immediately, presynaptically, the nerve terminal is free of a myelin sheet covering, creating a space of about 1.5  $\mu\text{m}$  where the nerve terminal is exposed to

the immediate environment (Bowden and Duchon, 1976). The nerve terminal appears to be embedded in the sarcoplasm of the muscle. The interior of the nerve terminal is filled with dense vesicular structures with a diameter of about 50 nm (deRobertis et al., 1954). In this case, these vesicles are thought to contain a neurotransmitter--acetylcholine. There are approximately 15,000 molecules of ACh per vesicle (MacIntosh et al., 1976). The pre-synaptic membrane is separated from the post-synaptic membrane by a space called the synaptic cleft. This is the area through which the neurotransmitter must travel to reach receptors located in the post-synaptic membrane. This post-synaptic membrane is specialized i.e., different from the extra-junctional membrane. Typically, the postsynaptic membrane is folded, forming clefts 0.5 to 0.7  $\mu\text{m}$  wide, thus increasing the surface area of the membrane. The extent of folding and the width of the cleft differs, depending on the species and the type of muscle investigated (Zacks, 1973). The crests of the junctional folds are covered with protein structures, identified as receptors by means of radiolabelled  $\alpha$ -BTX. These receptors are most dense in the region of the folds, extending only a short distance into their necks (Fertuck et al., 1974). The average density of the receptors at the mammalian endplate was calculated to be 3000/ $\mu\text{m}$ . Each receptor-channel complex is composed of five peptide chains arranged in a rosette-type of configuration with a diameter

of about 85 Å (Kistler et al., 1982).

An acetylcholine receptor-channel complex is arranged with the recognition sites for the transmitter located only on the outer membrane surface. del Castillo et al. (1955) has shown that only externally applied ACh will produce a response. Experiments evaluating ACh receptor-kinetics conclude that two molecules of ACh are needed to open one channel (Dreyer et al., 1978). This work was supported by biochemical studies, showing that each ACh receptor-channel complex has two almost identical ( $\alpha$ ) sub-units (Karlin, 1980). It is worth mentioning that despite the biochemical studies performed predominantly on the electric organs of either the Torpedo Californica, Torpedo Marmorata or, to a lesser extent, on the fresh water electric eel, both biochemically and physiologically, these receptors have proved to be related to mammalian, neuro-muscular receptors (Lindstrom et al., 1979; Lindstrom et al., 1979).

Besides the ACh receptor-channel complexes protruding into the junctional cleft, there are other proteins which play an essential role in the physiology of the NMJ. These proteins are acetylcholinesterases (AChEs). The location of these enzymes is in association with both pre- and post-junctional membranes with a greater concentration found at the latter site (Koelle et al., 1967). It appears that these enzymes are not integrated into the membranes, but rather coat them (Hall et al., 1971). Although not

completely understood, different species of these enzymes were identified (Hall, 1973). Using radio-labelled diisopropylfluorophosphonate (DFP), it has been estimated that the number of active hydrolytic sites per motor-endplate region is approximately the same as the number of ACh receptors (Barnard et al., 1971). Acetylcholinesterases are among the most efficient enzymes known, being capable of hydrolyzing a molecule of ACh in 80-100 microseconds (Wilson et al., 1961).



## PHYSIOLOGY OF THE NEUROMUSCULAR JUNCTION

Before a muscle becomes excited, enabling it to contract, the action potential propagates down the axon. When the action potential reaches the terminal, the electrical signal is transduced from an electrical to a chemical signal. As the chemical signal, a neurotransmitter (ACh) is released, ACh molecules travel from the release sites in the pre-synaptic membrane and through the synaptic cleft. Upon reaching their destination in the post-synaptic membrane, they bind with the receptors and activate the ionic channels. This leads to depolarization which in turn may or may not result in a muscle action potential. Muscle action potential generation depends upon the size of the depolarization relative to the threshold level. The depolarization level depends upon many processes: the amount of ACh released, the activity of AChEs, the integrity of the receptors and ionic channels, and the resting membrane potentials level as related to the membrane integrity. All of the above mentioned processes have been studied extensively and will be briefly reviewed here. More time will be devoted to those processes potentially involved in the effects of PLC on the NMJ (for a description of PLC activity, see the section on phospholipases).

## ACh Synthesis

Acetylcholine is synthesized from choline and acetylcoenzyme A in cholinergic axon terminals. This synthesis is catalyzed by the enzyme choline-o-acetyltransferase. This enzyme is believed to be synthesized in the cell body and then transported to the axon terminal (Ekstrom et al., 1971). In the terminal, some of the enzyme is found to be associated with membranes; it is speculated that these may be vesicular membranes (Fonnum, 1973).

Acetylcoenzyme A is synthesized in the mitochondria of the axon terminals under the direction of pyruvate dehydrogenase (Bremer, 1969). Since the inner mitochondrial membrane is impermeable to acetylcoenzyme A, investigators are uncertain how acetylcoenzyme A enters the cytosol (Tucek, 1967).

In motor neurons, small amounts of choline appears to be present in the axon terminals (Potter, 1970). The bulk of choline needed for the synthesis of acetylcholine is derived from the external environment. It appears that the extra-cellular concentration of choline remains constant (Bligh, 1952). Evidence suggests that at least 50% of ACh released at the terminal and then hydrolyzed by AChE, is reabsorbed into the axon terminal (Potter, 1970). The extracellular choline concentration is maintained principally by diet. Some is synthesized in the liver

(Bremer, 1961); the newest information suggests that some of it may come from phospholipid metabolism (Blusztajn and Wurtman, 1983; also see below).

Membrane phospholipids are a large, potential, choline depot. As it will be mentioned later, approximately 40% of the synaptic membrane phospholipids are in the form of phosphatidylcholine and 30% in the form of phosphatidylethanolamine (Barenholz, 1985). Both of these phospholipids are potential donors of choline. Choline may be generated from phosphatidylcholine by means of phospholipase D activity, or by means of phospholipase C activity, followed by the dephosphorylation by alkaline phosphatase. On the other hand, phosphatidylmethanolamine must first be converted to phosphocholine by serial methylations. The enzymes involved are one and two phosphatidylethanolamine N-methyltransferases (for review, see Blusztajn and Wurtman, 1983).

Choline, being a charged molecule, is not very lipid soluble. Thus, in order for it to re-enter the pre-synaptic cytosol, a special mechanism of transport must be present. A high affinity carrier system for the re-uptake of ACh was identified (Yamamura et al., 1972). It is suggested that the high affinity transport may be linked to the choline acetylation pathway. Therefore, substances which cannot be acetylated will not be picked up by this system. This supports the evidence that ACh is taken up by means of a

slow not a high affinity uptake system (Kuhar et al., 1974). The modulation of the fast choline uptake system has been demonstrated. Collier et al. (1969) has shown that there is a significant increase in the rate of choline uptake following the invasion of nerve impulses into the nerve terminals. This higher rate of uptake may be linked to an increase in axoplasmic  $\text{Na}^+$  (Yamamura et al., 1973). Also, an increase in ACh release was linked to the stimulation of high affinity transport mechanisms (Collier et al., 1974).

#### Axonal Action Potential

An axonal action potential is a self-propagating wave. Its polarity is the reverse of the resting membrane potential. The triggering mechanisms depend upon the system analyzed: they can be generated by the activation of a sensory transducer, by a voluntary decision made at higher centers or by a stimulating electrode. In this study, the axons of the phrenic nerve involved are principally  $\alpha$ -motoneurons. The  $\alpha$ -motoneurons range with respect to the diameter (9-20  $\mu\text{m}$ ) and conduction velocity (50-120 m/s) (Boyd et al., 1968). Conduction velocity is a temperature sensitive phenomenon, i.e., with decreasing temperature, there is a decrease in the velocity followed by a complete block (Paintal, 1965).

For the first time, in the early 1950s, Hodgkin and

Huxley were able to identify by means of the voltage clamp method, the ionic species involved in action potential generation (Hodgkin and Huxley, 1952 a-d). They identified two primary currents,  $\text{Na}^+$  and  $\text{K}^+$ . The first inward current, which reversed at +60 mV, was shown to be the  $\text{Na}^+$  current. The late currents, with an outward direction, reversing at a greater negativity than -60 mV, were  $\text{K}^+$  currents. They also showed the presence of a leakage current. Their work on the giant squid axon provided a framework for understanding voltage dependent changes in membrane permeability involved in the generation of the action potential.

In myelinated axons, a very specialized region, the node of Ranvier, is a gap between tightly wrapped, Schwann cells, measuring 1  $\mu\text{m}$  and containing 100 times more sodium channels as the unmyelinated fibers. It is the only area of the axon which is exposed to the external environment. In their early work, Huxley and Stampfi (1949) showed that in the regions between the nodes, the current was very small compared to the currents near or at the nodes. This observation gave the impression of a current jumping from node to node, thus, the name saltatory conduction.

There are many drugs that alter the action potential. Selective ionic channel blockers, like TEA, have different effects depending upon the mode of application. Extracellularly, TEA decreased the size of the  $\text{K}^+$  current in a dose dependent manner (Hille, 1967). Internally applied

TEA appeared to alter the kinetics of the  $K^+$  current, interacting only with open ionic channels. This block was shown to be partially reversed by an increase in the external  $K^+$  (Armstrong, 1972).

$Na^+$  channels are blocked selectively by nanomolar concentrations of tetrodotoxin (TTX) and saxitoxin (STX). When internally applied, these drugs show no efficacy (Narahashi, 1971). Local anesthetics are effective in blocking  $Na^+$  currents. This block seems to be voltage dependent (Strichartz, 1973). It is believed that anesthetics must enter the membrane before they can exert their action, because quaternary derivatives of these compounds are effective only from the inside (Frazier et al., 1970).

Toxins from the plant and animal kingdoms were found to play a role in altering gating processes. For example, scorpion venoms slow or abolish the  $Na^+$  channel inactivation, bringing about long duration action potentials (Koppenhofer et al., 1968; Narahashi, 1971; Witkop et al., 1984). Other toxins, such as butrachotoxin, shift the voltage dependence and slow the kinetics of  $Na^+$  channel activation (Seyama et al., 1976; Khodorow et al., 1975).

For many years, it was known that the  $Ca^{++}$  concentration had an effect upon the threshold of excitation in nerve action potential generation. Subsequently, some information has come to light regarding this phenomenon. By

means of voltage clamp experiments, it was shown that conductance-voltage curves for  $\text{Na}^+$  and  $\text{K}^+$  were shifted with different  $\text{Ca}^{++}$  concentrations (Hille, 1968). These experiments were used to estimate the amount of negative surface charge by using gating processes as detectors of electrical fields. The estimated density for negative charges about  $\text{Na}^+$  and  $\text{K}^+$  channels showed a trend pointing to 3 times as many negative charges associated with  $\text{Na}^+$  as with  $\text{K}^+$  (Vogel, 1974). An increasing  $\text{Ca}^{++}$  concentration may be perceived in hyperpolarization of the membrane or an increase in the membrane's electrical field near the channels. This change in the electrical field by screening negative charges near the  $\text{Na}^+$  channels by  $\text{Ca}^{++}$ , may alter the gating processes, leading to an elevated threshold of activation (Cahalan, 1978; Hille, 1985). Recently, the adaptability of axons to various challenges has been investigated by comparing the myelinated to the unmyelinated axons.

Non-myelinated fibers are considered to have uniformly organized membranes capable of impulse propagation. Myelinated axons, however, appear to have a very complex structure, which only now is understood in terms of its functional organization. The Schwann cells in the peripheral nervous system form compact, spirally arranged membranes with very high resistance and low tranverse capacitance. Thus, the only area capable of generating

ionic currents is the internodal region. These regions appear to be specialized in terms of their ionic channel's organization. Tritium-labelled saxitoxin, used to label Na<sup>+</sup> channels, revealed that under the myelin sheath, the density of these structures decreases from 10<sup>4</sup>/μm<sup>2</sup> to less than 25/μm<sup>2</sup>, according to the distance from the nodal region. Although there is growing evidence that voltage sensitive K<sup>+</sup> channels might not be involved in classical repolarization in myelinated mammalian axons (Brisman, 1980), they might be involved in rapid deactivation of Na<sup>+</sup> channels together with K<sup>+</sup> carried leakage current, flowing through more selective voltage independent channels. The presence of voltage sensitive K<sup>+</sup> channels is rare in the mature internodal region. However, in the developing pre-myelinated or injured, demyelinated axon, the presence of voltage sensitive channels is observed (Waxman and Foster, 1980; Chin et al., 1980). The contribution of K<sup>+</sup> channels to action potential electrogenesis changes with development; during pre-myelination, action potential integrity is dependent upon the K<sup>+</sup> channels. The significance of K<sup>+</sup> channels lessens with myelination. These observations point to the physiologic flexibility and complexity of the axonal membrane, action potential generation and propagation. There is also indirect evidence suggesting changes in axonal membrane fluidity. Bostock and Sears (1978) showed that in axons demyelinated by means of Diphtheria toxin, there is



continuous uninterrupted conduction. The axon's adaptive response to demyelination, by Diphtheria toxin, is a return to the pre-myelinated state, as once present in early development, with Na<sup>+</sup> and K<sup>+</sup> channels spread throughout the demyelinated region (Coria et al., 1984). These reorganizations undoubtedly involve changes in the microviscosity of the membrane in the affected area; however, to date, there is no literature addressing this issue.

#### Miniature Endplate Potentials (mEPP)

Classically, there are two ways by which ACh can be released from the nerve terminal; ACh can be released in response to an axonal action potential; and ACh can be liberated spontaneously. In 1951, Fatt and Katz first described these spontaneous potentials, or miniature endplate potentials (mEPPs). They found that these events were subthreshold in nature. Their size was reduced by curare (d-tubocurarine) and increased by prostigmine. Temperature and osmotic pressure increase resulted in an increased frequency of mEPPs. A study of Na<sup>+</sup> and Ca<sup>++</sup> effects upon these events indicated their independence from Ca<sup>++</sup>. A reduction in Na<sup>+</sup> concentration, however, decreased the size of the mEPPs.

The amplitudes of mEPPs are distributed in the normal fashion within a small range. Studies of various muscle

types in many different species, including man, show the above mentioned properties (see a review by Hubbard, 1973).

Under normal conditions, the amplitude of mEPPs depends upon the input impedance of the muscle fiber, which partially depends upon the diameter of the muscle fiber (Katz et al., 1957). When the muscle diameter decreases, the mEPP amplitude increases. Also, the amplitude of the mEPP can be enhanced by means of the inactivation of AChE, allowing more ACh molecules to interact with more ACh receptors. The location of a recording electrode is of importance; e.g., one observes a decrease in the amplitude by moving the electrode away from the end-plate region (Ginsborg, 1960). The mEPP is considered to represent a quantum of ACh, an integral number released in response to the axonal action potential. It is widely believed that the quantal release, as observed in a single mEPP, corresponds to one vesicle (deRobertis, 1964). This led to the postulation of the quantal hypothesis (Fatt & Katz, 1952; del Castillo and Katz, 1954; Liley, 1956). Recently, electrophysiologists (Kriebel et al., 1976; Kriebel et al., 1978) and biochemists (Israel et al., 1979) have challenged this hypothesis (for further discussion of the above topics, see the methods and discussion). In addition to ACh, the vesicle contains an acidic protein and ATP (Whittaker et al., 1979). This protein has been named "vesiculin". At this time, it is not clear what physiologic functions may be

ascribed to vesiculin and ATP.

The mEPPs frequency, a purely pre-synaptic phenomenon, can be influenced by many factors: increasing the  $Mg^{++}$  and reducing  $Ca^{++}$ , reduces the frequency of mEPPs; but generally, this effect is less significant than that obtained with regard to the evoked release (Hubbard et al., 1968). It appears that divalent cations like  $Ba^{++}$ ,  $Sr^{++}$ ,  $Co^{++}$  and  $Mn^{++}$  are capable of substituting for  $Ca^{++}$  in its absence. In its presence, however, a competition between the bivalent ions is observed, resulting in a reduction in the mEPPs frequency (Elmqvist and Feldman, 1966). An increase in  $K^+$  at the terminal ends, resulting in depolarization, exhibits an increase in the mEPP frequency that is enhanced by a reduction in  $Na^+$ .

Many drugs can also increase the mEPP frequency. For example, cardiac glycosides, catecholamines, and phenobarbitone, all increase the frequency of mEPPs (Birks and Cohen, 1968; Kuba, 1970).  $Ca^{++}$  ionophores, like X-537A, also have a potentiating effect (Kita and Van der Kloot, 1974). It is believed that this effect is mediated, at least in part, via an increase in intracellular  $Ca^{++}$ .

Venoms from different sources are found to be powerful ACh releasers, though they vary in terms of their mode of action. Some, such as the Black Widow spider venom, increase the frequency of mEPPs to the point of depletion (Longenecker et al., 1970); whereas, others like Taiwan-

banded Krait venom, produce a biphasic effect. The first phase is characterized by a rapid increase in the mEPP frequency followed, in the second phase, by a decrease (Chang et al., 1979). The agents found to decrease mEPP amplitude are numerous. They vary from toxins like Botulinum to endogenously occurring compounds like adenosine (Spitzer, 1972; Ginsborg and Hirst, 1972).

#### Endplate Potential (EPP)

According to the vesicular hypothesis, EPPs are composed of many unitary events (quanta) and are very similar in shape to mEPPs (Katz, 1969). The frequency of the EPPs is, of course, directly dependent upon the frequency of axon stimulation. The amplitude, however, depends upon a variety of factors. Boyd and Martin (1955) reported that the amplitude of EPPs decreases with an increase in the distance from the junction. This is related to the time course of the potential change which is determined by the passive electrical properties of the membrane (Fatt and Katz, 1951). The number of units composing EPPs were decreased with an increase in the concentration of  $Mg^{++}$  and a decrease in  $Ca^{++}$ , leading to a smaller amplitude. An increase in the  $Ca^{++}$  concentration of the Ringer, resulted in an increase in the quantum content. Boyd and Martin (1955) also observed that EPPs are temperature dependent. In curarized muscle, lowering the

bath temperature decreased the amplitudes of the EPPs; however, in a  $Mg^{++}$  blocked preparation, the opposite effect was seen; i.e., the amplitude of the EPPs increased with a decreased temperature. Lowering the temperature also increases the half decay-time of the EPPs.

The EPP's amplitude can be enhanced by increasing the quantal content; for example, cesium ions increase the amplitude of the axonal action potentials, thereby increasing acetylcholine release (Ginsborg et al., 1968). Drugs like tetraethylammonium, aminopyridines and guanidine, enhance ACh release by extending the duration of the axonal action potential (Koketsu, 1958; Horn et al., 1979). Another way of increasing the amplitude of EPPs and prolonging its decay-phase is by increasing the effective ACh concentration at the synaptic cleft. This may be accomplished using AChE-blockers. There are many compounds with the ability to inhibit AChE; they range from reversible, clinically-used drugs, like neostigmine, to potent, almost irreversible, organophosphorus drugs, like DFP.

#### Endplate Current (EPC)

The recording of EPPs with an intracellular microelectrode provides a useful measure of the amount of acetylcholine released from the nerve terminal and some gross appreciation for the post-synaptic membrane integrity;

it is, however, less useful in studying the mechanisms by which ACh-receptor complexes cause ionic current flow. More useful tools, in this respect, are concentration jump relaxation, voltage jump relaxation, noise analysis and single channel patch clamp recording. All of these methods are used to analyze ionic channel activity either indirectly, i.e., concentration jump relaxation, or directly, single-channel patch clamp analysis. In this work, concentration jump relaxation or the recording of the end-plate current (EPC), which is achieved by means of the voltage clamp (Takeuchi and Takeuchi, 1959) was used. There are similarities and differences between EPCs, EPPs, mEPCs, and mEPPs. Some of these will be pointed out.

The EPC amplitude is linearly related to the EPP amplitude in a narrow range, for example, in the amphibian neuromyal junction. This relationship holds up to 50 mA and 15 mV, whereas in the mammalian preparation, this relationship is valid up to 25 mA and 10 mV (McLachlan and Martin, 1981). The relationship between the holding potential and peak EPC amplitude is non-linear (Magleby and Stevens, 1972). In the case of elementary events (mEPCs), it was found that the linear relationship held (Anderson, 1973). Hyperpolarization of the post-synaptic membrane results in a decrease in the synchrony of conductance initiation as a result of the slowing of the EPC's growth phase (Magleby et al., 1972); thus a decrease in the

amplitude is expected.

As the temperature decreases, the amplitude of elementary events stays the same, while the amplitude of mEPCs decrease (Anderson and Stevens, 1973). Magleby and Stevens (1972) described the falling or decay-phase of the EPC in terms of a single, exponential time constant. Anderson and Stevens (1973) demonstrated that this decay is probably a measure of the randomly distributed lifetime of the ACh activated ionic channels, thus, suggesting that a change in the decay-time may reflect a change in the channel activity. This observation is supported by independent techniques, such as, noise analysis and patch clamp studies (Anderson and Stevens, 1973 & Neher and Steinbach, 1978). In accordance with this concept anticholinesterases enhances mEPC and EPC amplitudes (Gage et al., 1975).

The dependence of the decay-time upon decreased temperature and hyperpolarization has been established (Magleby and Stevens, 1972; Gage et al., 1975); both of these effects increase the decay-time of the EPC. Generally, acetylcholinesterases, as it may be predicted, increased the decay-time of EPCs and mEPCs (Eccles et al., 1942; Fatt and Katz, 1952). However, neostigmine was reported to shorten the decay-time (Kordas et al., 1975); whereas, physostigmine and DFP prolong it (Kordas et al., 1975; Kuba et al., 1974). There is a long list of agents involved in altering the exponential decay-phase of EPCs and

mEPCs (for a recent review, see Lambert et al., 1983). Some agents shorten the exponential decay; for example, d-tubocurarine, which acts in a voltage dependent fashion (Manalis, 1977), or pancuronium which prolongs the exponential decay and also alters its monophasic configuration to a biphasic configuration (Katz and Miledi, 1978). Other compounds, like short chain alcohols, prolong the decay-phase without alteration of its exponential form (Gage et al., 1975).



## PHARMACOLOGY OF THE NEUROMYAL JUNCTION

Neuromyal junctions, both amphibian and mammalian, have been used extensively as models in studies of drug effect upon synaptic transmission. Most of the studies involve drugs with very specific actions, i.e., receptor or channel blockers and agonists. In the section on the physiology of the neuromyal junction, the author concentrated upon drug effects which may resemble the activity of PLC, used in this study, in order to speculate on the possible mechanisms involved in PLC activity. It is important, however, to mention, generally, other well described pharmacologic agents (for a review, see Karczmar, 1966; Bowman, 1980). There are no specific inhibitors of ACh synthesis. Some compounds show a weak or a relatively unspecific inhibitory action; these are alpha-keto acids (Nachmason and John, 1944), barbiturates (Marks, 1956) and nitrogen mustards (Barron et al., 1948). High and low affinity choline transports across the membrane, on the other hand, are inhibited by several compounds. The best known is hemicholinium (HC-3). All of the compounds, in this group, contain choline-like moieties, for which Schueler coined the term "hemicholiniums". Besides being uptake blockers, some of these compounds also have post-junctional effects, e.g. HC-3 has a curarie-like effect (Bowman, 1980).

Acetylcholine esterase inhibitors are numerous and

qualitatively have a similar effect. The difference lies in their activity as defined by their structure; for example, lipid solubility is a factor determining the peripheral or central effect of compounds, such as, neostigmine and physostigmine, respectively. Another important factor is the time-course of action, ranging from the short reversible inhibition of AChE, by edrophonium to the long-lasting, irreversible block by DFP. There also appears to be selectivity in terms of the cholinergic sites. Most of the compounds, with the exception of edrophonium, have an effect upon the parasympathetic neuro-effector junctions (for a good review see Karczmar, 1966; Miyamoto, 1978).

Based upon the type of block produced, neuromuscular blockers can be divided into two groups: depolarizing and non-depolarizing. The first depolarizing blockers discovered were methonium compounds (Zaimis, 1954), followed by succinylcholine, carbonylcholine, etc. Although the mechanism of their action is complex, these drugs interact with the nicotinic receptors while depolarizing the post-synaptic membrane. For example, after opening the channels, decamethonium was shown to have a direct channel blocking effect (Adams and Sakman, 1978).

Depending on their action upon endplate current (EPC), ACh activity inhibitors may be grouped into two classes: competitive antagonists, such as d-tubocurarine, which reduces the amplitude of the EPC but does not alter its

course (Albuquerque et al., 1978) and non-competitive allosteric antagonists, such as belladonna alkaloids (Adler et al., 1976), local anesthetics (Adams, 1975), etc., that alter both the amplitude and the time-course of the EPC. They also were found to alter the synaptic current-voltage relationship.

In describing the pharmacology of the neuromuscular junction, one cannot help but mention the phenomenon of desensitization, described first by Katz and Thesleff (1957). Briefly stated, with repeated application of the agonist, there appears to be a diminution of the post-synaptic signal. On a microscopic level, the deactivation of the ionic channels appears to be analogous to  $\text{Na}^+$  inactivation; but probably, what this involves is the multiplicity of unresponsive states of those proteins formed slowly as the result of stimulation and that recover only during rest. This has been shown by both the conventional voltage clamp method (Feltz and Trautmann, 1982) and by single channel measurements (Sakmann et al., 1980).

## HISTORY OF PHOSPHOLIPIDS

The first observation implicating phosphorus as being bound to fatty substances was made in 1811, by L.N. Vaugeulin, as he investigated substances extracted from the brain; however, the true father of phospholipid chemistry is J.L.W. Thudichum as he carried out the fundamental work on the brain's chemical constitution. He isolated and attempted to classify many phospholipid fractions on the basis of their nitrogen-phosphorus ratio. Later, many of the substances which he separated from the brain were shown to be mixtures.

From brain tissue, Thudichum isolated a phospholipid which he designated as sphingomyelin. He was able to characterize it in terms of its constituents--mainly, the bases sphingosine and choline in addition to phosphoric acid and fatty acid. He also argued that "protagan" was not a distinctive substance but rather a mixture. Some years later, he was proven correct, when in 1927, MacLean discovered that "protagon" was a mixture of sphingomyelin and a cerebroside.

The knowledge of phospholipids progressed slowly because of difficulties with fractionation, the absence of structural information and the popularity of carbohydrate research. In the late 1950s, there was a revitalization in phospholipid research; first, because of improvements in techniques, but more importantly, because lipids became

fashionable. With the enhanced interest in membranes and their composition, it became obvious that many membranes consisted largely of phospholipids and that phospholipid metabolism had to be elucidated. We now know that lipids and related compounds are essential in the functioning of the membrane's machinery; moreover, it is becoming apparent that phospholipids play a role in the transport of ions across membranes and serve as substrates for the de novo synthesis of acetylcholine.

#### Action of Phospholipases

The enzymatic action of phospholipases upon phospholipids is illustrated in Figure 0.

The structure of phospholipids is based on a three carbon backbone originating from glycerol. These carbons are numbered from three to one, starting with the phosphate-attached carbon. The "X" in Figure 0 represents any of the typical radicals. The terminology of phospholipids is derived from the characteristic radical; for example, if "X" is choline, then the phospholipid in question is named phosphatidylcholine.

The nomenclature of phospholipases has been standardized. The enzymes affecting the ester bond on carbon-1 (C1) and carbon-2 (C2) are referred to as phospholipase A1 (PLA1) and phospholipase A2 (PLA2), respectively. Two types of phospholipases affecting the

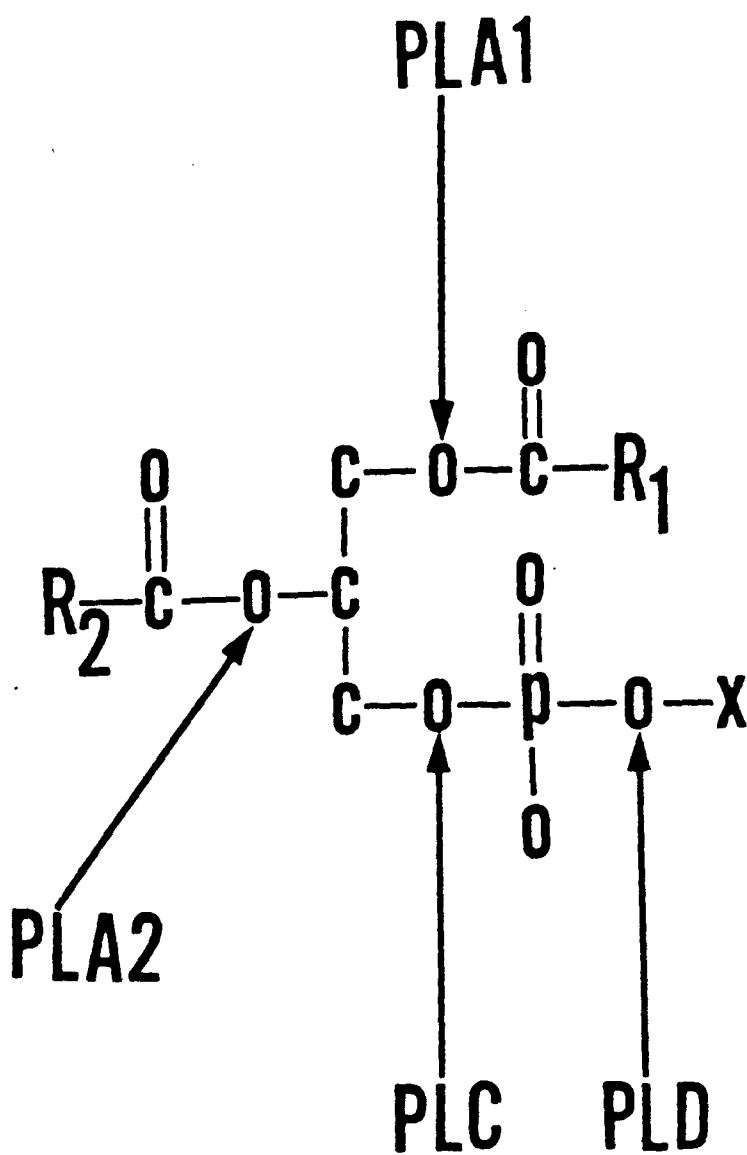
## FIGURE 0

Structure of a phospholipid with specific phospholipase actions upon it.

$R_1$  = Phospholipid moiety.

$R_2$  = Phospholipid moiety.

X = Non-phospholipid moiety.



chain originating from C3 act similarly to PLA1 and PLA2 by cleaving ester bonds and liberating phosphate containing compounds (P-X). In the case of phospholipase D (PLD), its action upon a phospholipid results in the liberation of the X-side chain, leaving behind phosphatidic acid.



## GENERAL BIOCHEMISTRY OF PHOSPHOLIPASES

## Phospholipases A1 and A2

A short review of work carried out to establish the efficacy and properties of phospholipases follows:

Phospholipase A1 and A2, enzymes which hydrolyze ester linkages on C1 and C2, respectively, of the diacylglycerophosphoryl base, have been purified from many sources, e.g., snake and bee venoms, bacteria and many mammalian tissues. In 1971, Scandella purified an enzyme with a specific PLA1 activity, which was 1,200 times more active than the original material of Escherichia coli where PLA1 was present in the outer membranes of the bacterium; this enzyme was found to have a molecular weight of approximately 60,000. It is inhibited by Na<sup>+</sup> and activated by Ca<sup>++</sup> (this is not true for all species of PLA1; see below). Its optimal pH is 8.0. Raybin et al. (1972) studied an enzyme (PLA) specific for the carbon-1 position of phospholipids which was obtained from the spores of Bacillus megathenium. He purified the enzyme 170 times and found no need for Ca<sup>++</sup> as an activator.

Phospholipase A1 is widespread throughout mammalian tissue, as it is found in practically every subcellular fraction of the cell (Gatt et al., 1973). The properties of PLA1 differ depending on its location and the pH optimum. For example, brain PLA1 is heat labile and does not exhibit

Ca<sup>++</sup> dependence for its activation; while PLA1 from guinea pig pancreas has a pH optimum of 6.0 and is inhibited by Ca<sup>++</sup> (White et al., 1971). Rat liver PLA1, found in plasma membranes and microsomal fractions, exhibited a pH optimum of 9.0 and was found to be activated by Ca<sup>++</sup> (Newkirk et al., 1971), as does PLA1 derived from E. coli.

PLA2 is probably the most studied lipase. Depending on the source, its molecular weight may vary from 8,400 (Salach, 1971) to almost 30,000 (Wells et al., 1969). Pancreatic PLA2 has been completely sequenced; it is a single chain protein with six disulfide bridges (deHaas et al., 1971). At the C-end of the chain, there is a concentration of basic amino acids whose cleavage renders this enzyme inactive (Scanu et al., 1969). It has been demonstrated that pancreatic PLA2 has a Ca<sup>++</sup> requirement for activation (Augustyn, 1970). However, Vipora russellii phospholipase was found to be inhibited by Ca<sup>++</sup> and other divalent cations (Slotboom, 1970). The optimal substrate for PLA2s depends on the source of the PLA2. PLA2 from Laticauda semifasciata exhibits a high specificity for phosphatidylethanolamine as a preferred substrate (deHaas, 1968). The properties of PLA2s obtained from several mammalian sources have been described, including PLA2s of the arteries, heart muscle, and liver mitochondria of different species. It appears that all of these enzymes have a basic pH optimum activated by Ca<sup>++</sup> and have an

affinity for phosphatidylethanolamine as a substrate. However, enzymes located in the lysosomal fraction of liver, and human and rat brain have pH optima in the acidic range and are inhibited by  $\text{Ca}^{++}$ . More specific localization studies show that rat hepatocytes contain mitochondrial PLA2 with a basic pH optimum and  $\text{Ca}^{++}$  dependency; while it is primarily localized in the outer membrane (Nachbaur, 1972), there also seems to be significant activity present in the inner membrane. Many mammalian tissues contain both PLA1 and PLA2; in the case of rat liver plasma membranes, PLA1 and PLA2 are activated by  $\text{Ca}^{++}$ , but the relative activity of these enzymes is dependent upon the substrate used. PLA2 had a high specificity for phosphatidylglycerol, whereas PLA1 was more active in the presence of phosphatidylethanolamine (Newkirk, 1973).

#### Phospholipase C (PLC)

In 1971, Zwaal et al. purified PLC from Bacillus cereus. This purification generated a product with a molecular weight of 21-25,000 Daltons. This enzyme required  $\text{Ca}^{++}$  for activation. PLC did not hemolyze erythrocytes, but could degrade phospholipids of erythrocyte ghosts (Gatt, 1973). Casu et al. (1971) prepared a purified form of PLC from Clostridium perfringens: its molecular weight was estimated at 90,000; and its activity was dependent on  $\text{Ca}^{++}$  ions. This PLC differed from the enzyme derived from

Bacillus cereus in that it had strong hemolytic activity. PLC degraded phospholipids present in fragments of purified myelin (McIlwain, 1971); as much as 70% to 90% of phosphatidylethanolamine, phosphatidylcholine and sphingomyelin was degraded; but only a small amount (14%) of phosphatidylserine was affected. Koeugh (1972) found PLC in the microsomes and cytosol of bovine brain. Hostetler et al. (1980) carried out a very extensive study of PLC involving the analysis of many rat tissues: adipose tissue, brain, diaphragm, duodenum, heart, ileum, jejunum, kidney, liver, lung, skeletal muscle and spleen. They found that all of these tissues exhibited PLC activity. These enzymes appeared to have optimal activity in an acidic pH.

#### Phospholipase D (PLD)

For a long time, the only source of PLD was from plant homogenates such as cabbage, sugar beets, spinach, cottonseed and peanut seed (Kates et al., 1963). PLD from these sources showed a broad range of activities toward phospholipids; in order of decreasing hydrolysis rate these phospholipids were lecithin, phosphatidylethanolamine and phosphatidylserine. This enzyme exhibited optimal activity at an acidic optimum pH; but there was variability in this respect, as the true optimum depended on the source (Einset et al., 1958; Tookey, 1956). It has been shown that PLD requires  $\text{Ca}^{++}$  for activation and that other divalent cations

cannot substitute for  $\text{Ca}^{++}$ . Besides having hydrolytic properties, as described above, PLD also exhibits transferase activity which, in the presence of alcohols such as glycerol, methanol and ethanol, aids in the transfer of a substrate, i.e., lecithin or phosphatidylethanolamine, to the acceptor alcohol (Yang et al., 1967). PLD is present in mammalian tissues; e.g., Chalifour, et al. (1980) reported the presence of PLD in rat brains. They purified this PLD and showed that it possessed dual activity, i.e., hydrolytic and transferase properties. It has been reported that activation of PLD from rat brain and lung microsomes was undetectable without the presence of detergents, like bile acids or unsaturated fatty acids (Chalifour et al., 1980). Chalifour et al. (1982) carried out further studies the activation phenomenon as they investigated the activity of PLD in many rat tissues: brain, epididymal fat pad, heart, intestinal mucosa, kidney, liver, lung, skeletal muscle, spleen and testes. As measured by the formation of phosphatidic acid from  $\text{H}^3\text{-I-phosphatidylcholine}$ , all of these tissues exhibited PLD activity. In addition, it became apparent that the activation of PLD could be accomplished by means of unsaturated, long chain fatty acids naturally occurring in its environment.

## Effects of Phospholipases A<sub>1</sub>, A<sub>2</sub>, D and C on Tissue Models

In 1966, Albuquerque and Thesleff studied the effects of phospholipase C on the electrical properties of skeletal muscle membrane. They used two models, innervated and denervated skeletal muscle of the rat. They also compared the action of PLC on slow versus fast muscle in the chicken and rat. Considering the resting membrane potential, input resistance, action potential and acetylcholine sensitivity, they found that with doses higher than 1.5  $\mu\text{g/ml}$ , there was a significant fall in the membrane resistance over time. In the rat and the chicken, the most significant effect was found in the case of the fast muscle. Denervated muscle, whether fast or slow, was more resistant to the effects of phospholipase-C on membrane resistance. Within one hour after applying 1.5  $\mu\text{g/ml}$  of PLC, the action potential was found to be totally and irreversibly blocked; innervated and denervated muscles were equally sensitive to this effect of PLC. There was no effect on the input resistance (IR) and the resting membrane potential (RMP). Acetylcholine sensitivity was reduced with a PLC concentration which abolished the electrical excitability of the membrane. Subsequently, Albuquerque et al. (1967) investigated the interaction of divalent cations with PLC treated mammalian skeletal muscular membrane. PLC's inhibition of action potential generation was somewhat similar to the action of local anesthetics (Shanes et al., 1959); but it differed in

that PLC had a pronounced effect upon the RMP. The investigators found that after PLC application, washing did not restore action potential generation. However, by increasing the calcium concentration from 2 mM to 15 mM, there was repolarization of the membrane followed by restoration of the action potential. Analysis of the latter, by means of low sodium Ringer perfusion and a specific sodium channel blocker (tetrodotoxin) indicated that this action potential was sodium generated. Calcium's effects were antagonized by ions such as caesium and rubidium.

Watson et al. (1976), in their investigation of the denervation sensitivity phenomenon, found that PLC (5  $\mu\text{g/ml}$ ) and phospholipase D (PLD 5  $\mu\text{g/ml}$ ) had a similar effect on muscle contraction as did the homogenate, 2  $\mu\text{g/ml}$ , of the denervated muscle. By investigating the contraction response of skeletal muscle to ACh applied in the bath, they observed an approximately two-fold increase in contracture with denervated muscle cytosol, PLC and PLD. Phospholipase A and other enzymes like trypsin, collagenase and protease, were shown to have no effect. Also, to exclude the possibility that the effect might be due to the anticholinesterase activity of PLC or PLD, ACh was substituted with carbachol; it was found that there was no difference in the effect of PLC or PLD on either the ACh or carbachol responses. The RMP was monitored throughout the

experiment and there was no significant effect of PLC or PLD on the RMP. The authors ascribed the potentiation effect of PLC, PLD and cytosol to their interaction with membrane phospholipids resulting in the unmasking of spare receptors.

Harborne et al. (1978) directly addressed the issue of PLC, cytosol and pepsin-induced increase in ACh and carbachol sensitivity being related to the availability of spare receptor. They too measured isometric muscle contraction generated by ACh perfusion and monitored the RMP.

Harborne et al. (1978) incubated the preparation in  $\alpha$ -bungarotoxin at a concentration of .001 g/l. Subsequently, a block of the response to ACh was observed. The PLC treatment followed. It was observed that there was a recovery of the response; but its magnitude was 28% less than the amplitude of the ACh response of the controls. In the absence of an  $\alpha$ -bungarotoxin block, PLC treatment potentiated the ACh response by 104% above the control. These results seemed to support the spare receptor hypothesis. The drug concentrations and the effects obtained by these two groups of investigators cannot be readily compared because the units were expressed not in  $\mu\text{g/ml}$  but rather in units of activity per ml (u/ml).

The studies mentioned above concerned the post-junctional effect of PLC and PLD. Using microelectrode techniques with the sciatic nerve/sartorius muscle of the frog, Ohta and Karczmar (1981) and Ohta et al. (1981)



explored both the pre- and post-synaptic effects of PLC. They found that the RMP and the membrane resistance did not change with a drug concentration of .1-1  $\mu\text{g/ml}$ ; however, at a concentration of 3  $\mu\text{g/ml}$ , the RMP and input impedance were reduced; a reversal of this effect was not observed within 1 hour of washing. The effects of PLC upon the excitatory post-synaptic current (EPC) were dose and time dependent; i.e. a higher concentration required less time for the onset of the peak drug effect. The increase in the response was in the range of 10% as compared to the control. However, inhibition of the response was observed with continuing drug application. Similar effects were observed in the experiments involving the analysis of the excitatory post-synaptic potential (EPP). It was also noted that the shapes of the waveforms (EPC, EPP) were affected by the drug: while the upstroke was not changed, the decay was prolonged. The investigation of the ACh potential pointed to some differences between the effects of PLC on the EPP, EPC and ACh response; the augmentation effect on the ACh potential was not as extensive. The peak influence of PLC upon the ACh potential compared to the EPP differed temporally. Also, there was no secondary diminution of PLC induced potentiation. When the effect of PLC on the spontaneous release of ACh was investigated, it was observed that PLC at a concentration of .3  $\mu\text{g/ml}$  significantly increased the frequency of mEPPs by 105%; it increased the amplitude of

mEPPs by 20-30%. The time course of the effect was very similar to that of the effect of PLC on the EPP and EPC. Calculated by means of the failure method, the quantal content showed an augmentation; this effect was reversed with washout. An investigation of  $Ca^{++}$ 's role in the effect of PLC was conducted; it was found that PLC had a potentiating effect in low, normal and high  $Ca^{++}$ ; but, the highest increase occurred in the low  $Ca^{++}$  solution. When drugs effecting  $Ca^{++}$  flux such as dantrolene were used, PLC did not induce potentiation as it prevented PLC action on the EPP and EPC amplitude; also, dantrolene prevented the augmenting effect of PLC on the quantal content. Verapamil inhibited the quantal content augmentation observed with PLC and blocked the potentiation of EPC and EPP amplitudes. Finally, used in low concentrations verapamil decreased the duration of PLC augmentation. The study also demonstrated the  $Ca^{++}$  dependence of PLC facilitation on the spontaneous and evoked ACh release. It was suggested that PLC, on the one hand and dantrolene and verapamil on the other had opposing effects upon  $Ca^{++}$  involvement in neurotransmitter release phenomena.

The earlier studies, (Nelson, 1958; Narahashi and Tobias, 1964) in which crude preparations of PLC were used upon frog nerve fiber and lobster giant axon, showed that PLC caused gradual membrane depolarization and an eventual block of the action potential conduction. Rosenberg and

Condrea (1968), by using a more purified preparation of PLC from Clostridium welchii in a concentration of 90 u/ml for 30 minutes, found that there was no significant change in the conduction and shape of the action potential. They concluded that axonal conduction and membrane permeability can be maintained in the presence of extensive phospholipid splitting; 100% sphingomyelin, 84% lecithin and 50% ethanolamine. Depending on the experimental condition, PLC from Clostridium welchii could eliminate from 85-100% of the phosphorylated bases with 87% to 93% of the diglycerides remaining within the membrane (Rosenberg, 1970). This result suggests the role of phospholipids play in the function of axonal membranes. However, purified PLC had no effect when applied to the outside of the squid axon (Rosenberg and Condrea, 1968). Internal application of this purified enzyme depolarized the membrane and blocked signal conduction (Tasaki and Takenaka, 1964). Hinzen (1977) studied the effects of PLC and PLA upon Aplysia neurons by means of the voltage clamp technique. He analyzed the ionic conductance and currents resulting from an internal application of pure PLC and PLA. He found that PLA rapidly decreased the membrane potential and resistance and markedly depressed the peak transient current; there was little effect upon the late, outward current. The PLC that was used was obtained from two sources: PLC obtained from Bacillus cereus, caused strong hyperpolarization, decrease

in the membrane resistance, and marked increase in the late, outward current; while PLC obtained from Clostridium welchii caused a marked increase in the resting membrane resistance (RMR) as well as hyperpolarization. The external application of these enzymes was ineffective. The conclusion drawn from the data was that phospholipases, from different sources, have distinct pharmacological actions which differ depending on the preferred substrate of the phospholipase in question.

#### Ionic Mechanisms Involved in PLC Activity

The effects of PLC originating from Clostridium welchii on the frog skin was examined by Yorio et al. (1976), who found that at 50  $\mu\text{g/ml}$  PLC exerted a reversible activating effect upon transepithelial  $\text{Na}^+$  transport as reflected by means of the potentiation of a short circuit current. This PLC activity was abolished by means of simultaneous perfusion with amiloride (.0001 M), a specific inhibitor of  $\text{Na}^+$  transport across such epithelia (Bentley, 1968). Yorio et al. (1976) also found that aldosterone appeared to have an additive effect with PLC. The conclusion drawn from the data implicates this highly specific enzyme, PLC, in a selective activity promoting reversible activation of  $\text{Na}^+$  influx. In 1983, Philipson et al. investigated the effects of PLC obtained from both sources, i.e., Clostridium perfringens and Bacillus cereus, upon

cardiac sarcolemmal vesicles. Sarcoplasmic vesicles loaded with  $\text{Na}^+$  were exposed to PLC, 0.25-5 u/ml; then, the vesicles were exposed to a  $\text{Ca}^{++}$  uptake medium, containing 45 mM  $\text{CaCl}_2$ . The  $\text{Ca}^{++}$ - $\text{Na}^+$  exchange reaction was stopped by adding KCl and  $\text{LaCl}_3$ . Thin layer chromatography was used to analyze the phospholipids. Electron microscopy was also performed. The results indicate that both types of PLC have an activating effect upon  $\text{Na}^+$ - $\text{Ca}^{++}$  exchange. This effect differed quantitatively depending on the origin of the enzyme. The enzyme obtained from Clostridium perfringens had a greater effect upon the  $\text{Na}^+$ - $\text{Ca}^{++}$  exchange than that obtained from Bacillus cereus. There was also an increase of passive  $\text{Ca}^{++}$  flux with the former. The analysis of phospholipids before and after PLC treatment revealed that the main substrates for the enzymatic activity were phosphatidylcholine, phosphatidylethanolamine and sphingomyelin, while other phospholipids, i.e., phosphatidylserine and phosphatidylinositol were left relatively intact. Electron microscopy revealed gross changes in the PLC treated vesicles. The authors expressed their surprise that "such severe structural damage can demonstrate enhanced transport activity."

PLC has also been tested with respect to additional systems and it was found to inhibit the activity of several

transport enzymes, for example,  $\text{Na}^+\text{-K}^+\text{-ATPase}$  (DePont, 1978) of red blood cells,  $\text{Ca}_2\text{-MgO}_2\text{-ATPase}$  (Roelofsen, 1977) of the sarcoplasmic reticulum and  $\text{K}^+\text{-H}^+\text{-ATPase}$  (Schrijen, 1981) in gastric cells.

## MEMBRANE LIPIDS AND PROTEINS

### Membrane Lipids and Fluidity

In reviewing the literature concerned with the physical properties of membranes, such as fluidity, microviscosity and ordering versus disordering, one has a great deal of difficulty understanding the true significance of the descriptive terms above. It seems that fluidity is an all encompassing term. Fluidity describes the diffusion of molecules in a lateral, as well as, transverse direction, the flexibility of acyl chains and the rotational movement of proteins; whereas, microviscosity refers to a very small portion of the membrane i.e., the environment about the receptor proteins. The terms ordering and disordering appear to reflect the functional state of the membrane; for example, an increase in fluidity corresponds to ordering rather than disordering.

Several types of investigative techniques are used in studying the membrane. First, electrophysiologic methods, though indirect, are a more physiologic way of measuring the effect of drugs upon lipid membranes (Gage et al., 1974). Second, a biochemical method of investigation involves the use of a probe in the form of a potentially excitable substance capable of entering into the membrane. This probe can be of any chemical structure as long as it will respond with motion to activation, e.g., by a magnetic field.

Another method used is electron-spin-resonance. In this method, spin labels are derived from a natural membrane component to which a nitroxid group is attached. Still another method is the fluorescence-polarization technique; in this case, a membrane-bound dye, excited by polarized light, emits a light pattern; the amount of light emitted depends upon the fluidity of the membrane, i.e., a reduction in emission means increased fluidity. These studies do not evaluate the functional integrity of the membranes, but rather, directly measure their physical state.

Fluidity is influenced by the chemical composition of the membrane. Cholesterol has been shown to be one of the main lipid rigidifiers in natural membranes (Shinitzky et al., 1976). Cholesterol associates more readily with some lipids than others; for example, sphingomyelin and cholesterol have a greater affinity for each other than lipids like phosphatidylcholine (Dekruijff et al., 1974). The cholesterol/phospholipid ratio was shown to be a good index of membrane fluidity with cholesterol being a rigidifying moiety (Cooper, 1977).

During membrane biogenesis, the selection of saturated and unsaturated fatty acids in the membrane structure contributes to the degree of membrane fluidity. This structure can then be modified by enzyme "desaturases" which can increase or decrease the number of double bonds (Oshino et al., 1972) and modulate the length of the fatty acids



(Dickens et al., 1982). The first insertion of one double bond into a fully saturated fatty acid has a much greater fluidizing effect than any subsequent insertions (Stubbs, et al., 1981).

Individual phospholipids, having varied physiochemical properties, contribute differently to the fluidity of membranes. For example, lecithin contributes to fluidization, whereas sphingomyelin contributes to rigidification (Shinitzky, 1974). Phosphatidylethanolamine is another membrane rigidifier; however, when it is methylated by membrane bound enzymes to form phosphatidylcholine, membrane fluidity increases (Hirata and Axelrod, 1980). Other lipids like phosphatidylserine and phosphatidylinositol are relatively unsaturated and may be compared to lecithin (Shinitzky et al., 1979); whereas sphingoglycolipids are similar to sphingomyelin and can be considered as lipid rigidifiers. Synaptic membranes, as compared to others, have a lower cholesterol/phospholipid ratio, a higher lipid/protein ratio and a higher ganglioside level (Dod et al., 1968). Depending on the type of preparation, the composition of the synaptic membranes vary greatly in terms of their specific phospholipids. For example, the quantity of phosphatidylserine varies from 8% (Harris, unpublished observation) to 18% (Hitzemann et al., 1983).

The phospholipids of the synaptic membranes appear to be asymmetrically distributed, with phosphatidylcholine localized at the outer surface, and phosphatidylethanolamine as well as phosphatidylserine predominantly on the inner surface (Fontaine et al., 1980).

### Proteins of the Membrane

Proteins embedded in the membranes may be divided into two types, integral proteins and peripheral proteins. These two types differ in several ways: Although peripheral proteins have a relatively consistent molecular weight, integral proteins vary greatly in molecular weight (Lenar, 1970). Integral proteins are assumed to be critically involved in the structural integrity of the membrane and are difficult to dissociate from the membranes. They are also found to protrude into one or both aqueous phases. On the other hand, peripheral proteins are easily dissociated after treating membranes with mild chelating agents, and when dissociated, are totally free of lipids (Singer & Nicolson, 1972).

The position of a membrane protein is under thermodynamic control (Tanford, 1978). Hydrophobic forces maintain the protein within the membrane while hydrophilic forces pull it out. These two membrane forces combine to establish the protein's position of equilibrium. Conceptually, altering the strength of either one of these

forces will lead to a modification in the protein position within the membrane, exposing it to the aqueous phase or hiding it in the lipid phase. Membrane modification can lead to observable changes in the protein's behavior as it was noted by Borochoy and Shinitzky (1976). They formulated a "vertical displacement hypothesis" which states that rigidification of the membrane results in the vertical displacement of the membranes towards the aqueous side.

Within the membranes, other protein mobilities include the lateral and the rotational diffusions. A substantial portion of membrane proteins may appear immobile (Shinitzky, 1983); however, these proteins can move when associated with metabolic processes (Edelman, 1976); or for example, micro-aggregation of receptors in the case of the hormone-receptor interaction (Schlessinger, 1980). Rotational diffusion of membranes is related to the immediate environment of the lipids. Bienvenue et al. (1977) has shown, using choline esters of spin-labelled fatty acids in a preparation of the electric organ of a Torpedo, that despite a highly clustered organization of proteins in the post-synaptic region, there is lipid-mediated fluidity. This fluidity may be effected by changes in microviscosity.

#### Membrane Fluidity and Proteins

Several studies have addressed the question of how fluidity effects the membrane receptors. Generally

speaking, the receptors involved in neuronal communication are most effected by changes in membrane microviscosity (Heron et al., 1981). Ligand binding studies have shown that in crude, mouse forebrain membranes, when the fluidity of the membrane was increased by incubation with lecithin, the binding was decreased; whereas in the case of rigidifying treatment with cholesterol, the binding increased (Hershkowitz, 1982). Changes in the membrane potential were observed to alter membrane fluidity with depolarization, decreasing viscosity (Corda et al., 1982) and increasing viscosity with hyperpolarization (Georgescauld et al., 1978).

More permanent rigidifying changes in membrane fluidity were observed in aging. These changes were associated with an alteration in the constituents of the membrane. Significant increases in cholesterol, sphingomyelin and glycosphingolipids were observed (Rouser and Yamamoto, 1968). Also, there were changes in the degree of saturation of the lipid chains (Hubbard and Garrett, 1980).

#### Drugs and membrane fluidity

Many drugs have been investigated in terms of their effects on membrane properties, i.e., its organization. General anesthetics, like halothane and methoxyflurane, were shown to have disordering effects on the membranes

(Mastrangelo et al., 1978). Local anesthetics and other drugs showed varied effects depending on the type of membrane preparation (Neal et al., 1976) and drug used (Butler et al., 1973); for example, xylocaine exerted weak disordering effects on the membranes of RBCs (Hubbell et al., 1970) while other local anesthetics had no effect upon synthetic membranes and liposomes (Rosenberg et al., 1977). Barbiturates and related drugs were shown to have a biphasic effect in terms of their action on the membrane. This effect was membrane-content dependent; for example, in low cholesterol membranes, chlorpromazine had an ordering effect; whereas in high cholesterol membranes disordering occurred (Pang et al., 1978). Normal, branched and secondary alcohols of up to 8 carbon units had a disordering effect upon membranes. Ethanol, because of its importance in the everyday life of many members of the population, has been studied extensively. Using the techniques described above, it was shown that ethanol generally has a disordering effect upon membranes (Chin et al., 1977; Harris et al., 1980). It was shown by Chin et al. (1981) that the disordering properties of ethanol can be antagonized by cholesterol, suggesting that ethanol may have a greater effect upon fluid membranes. Chin et al. (1978) showed also an increased cholesterol content in the synaptic membranes of mice chronically treated with ethanol. In addition, myelin, as compared to synaptic membranes, was sensitive to

ethanol treatment (Harris et al., 1982). A hypothesis has been developed which states that alcohols have a preferential effect upon fluid membranes. Chronic administration may lead to rigidification of the membrane's structure through a change in the lipid to cholesterol ratio.

Electrophysiologic studies of general anesthetics, local anesthetics, barbiturates and alcohols of different chain length, upon synaptic membranes, directed at relating electrophysiology and membrane phospholipids have been extensive (Beam, 1976; Torda et al., 1976; Gage et al., 1975 and Gage and Hammil, 1981). The general effect of these compounds is dose and lipid solubility dependent. A decrease in the amplitude and increase in the rate of decay was observed in the synaptic signals, MEPPs and EPPs. Some interesting observations have been made by Gage et al. (1975) in studying the effects of ethanol upon neuromyal transmission. They observed a prolonged lifetime of endplate channels expressed by the prolonged miniature endplate current's (EPC) decay-time. They proposed that the closing of open ionic channels was slowed. They attributed these findings to alcohol's interaction with membrane lipids, more specifically, to changing the membrane's dielectric constant through its incorporation into the lipid bilayer.

## PURPOSE

Phospholipase C (PLC) is ubiquitous in mammalian systems (Hostetla, 1980). Its functional importance is not clear; biochemically, it is a specific enzyme involved in cleaving the diester bond on the third carbon in the phospholipid moiety. Hokin and Hokin (1954) discovered that P32 is incorporated into phosphatidate as a result of acetylcholine (ACh) and noradrenaline (NE) stimulation (Hokin, 1969). This discovery directed investigators towards a hypothesis postulated by Michell (1975), which suggests that receptor-stimulated breakdown of phosphatidylinositol via PLC might be implicated in a general mechanism of increasing cytosolic  $Ca^{++}$  concentration. Other investigators proposed that PLC may be involved in unmasking spare receptors (Watson et al., 1976 and Harborne et al., 1978). Ohta and Karczmar (1981) investigated these hypotheses in the amphibian neuromyal junction (NMJ). They found that in this preparation PLC has a complex action as pre- and post-synaptic effects were seen. In addition, they found that PLC had an effect on the membrane's calcium permeability. They hypothesized that this result was due to an alteration in membrane fluidity.

The working hypothesis of this thesis is based upon these facts and/or assumptions:

- 1) Phospholipids are an integral part of neuromyal membranes.
- 2) Phospholipids are closely associated with proteins.
- 3) Receptor-ion channel complexes are made of proteins embedded in the lipid layers.

This then leads to the hypothesis that alterations of the membrane lipid structures should have an effect upon the functional integrity of a system.

#### Working Hypothesis

Hydrolysis of the phospholipids in the pre- and post-synaptic mammalian membranes will result in an alteration of transmission at the neuromyal junction. Phospholipase C, an enzyme that has a well-documented effect on phospholipids, and appropriate electrophysiological methods will be used as tools in examining this hypothesis.

#### Experimental Goals

1. To observe if PLC from Clostridium welchii has an effect upon the mammalian NMJ affecting neuromyal transmission.



2. If the above is true, investigate the effect of PLC on pre- and post-synaptic indicators of neuromyal transmission.

A. Pre-synaptic effect evaluation

1. Extracellular compound axonal action potential recording
2. Intracellular recording
  - a. mEPP frequency
  - b. quantal content evaluation by two methods:
    - i) low  $Ca^{++}$ /high  $Mg^{++}$
    - ii) dtc-induced half-block

B. Post-synaptic effect evaluation

1. Dose response relative to RMP
2. Effect of PLC upon
  - a. EPP amplitude
  - b. EPP waveform, i.e. rise and decay-time
  - c. EPC amplitude

- d. EPC waveform, i.e. decay-times
- e. mEPP amplitude
- f. ACh potential
- g. Carbachol potential
- h. Electrotonic potential

## METHODS

### Experimental Animals

Male CF1 mice were obtained from the Charles River Breeding Laboratory. The mean weight of the animals was 39 grams. Mice with gross organ pathologies were not used. The animals acclimatized for 2 weeks before they were used for experimentation. All of the experiments began at the same time of day.

### Dissection of the Phrenic Nerve-Diaphragm Preparation

A mouse was decapitated and strapped to the dissection table by the limbs. The skin was incised down the ventral midline and separated from the abdominal and thoracic body wall. The pectoralis muscle groups were removed from the ribcage. The abdominal perineum was cut away from the ribcage. A midline, caudal cut was made along the sternum. To one side, a lateral cut was made, leaving the diaphragm attached to one or two ribs. The phrenic nerve was identified by following the nerve rostrally to the region of the thymus. In that region, the nerve was ligated and cut proximally to the site of ligation. The same procedure was followed on the other side of the animal. A dorsal cut liberated the diaphragm. With both phrenic nerves attached, the diaphragm was transferred into a chamber containing Ringer solution. There, the diaphragm

## TABLE 0

This table shows the composition of the perfusates used in the present work.

RINGER PERFUSATES

COMPONENTS OF NORMAL AND MODIFIED RINGER - LOCKE SOLUTIONS

EMPLOYED IN THIS STUDY WERE AS FOLLOWS:

<u>COMPONENTS</u>	<u>NORMAL RINGER</u>	<u>LOW Ca<sup>++</sup>/HIGH Mg<sup>++</sup> RINGER</u>
NaCl	136.8 mM	136.8 mM
KCl	5.0 mM	5.0 mM
CaCl <sub>2</sub> .2H <sub>2</sub> O	2.0 mM	0.23 mM
MgCl <sub>2</sub> .6H <sub>2</sub> O	1.0 mM	11.0 mM
NaHCO <sub>3</sub>	12.0 mM	12.0 mM
NaH <sub>2</sub> PO <sub>4</sub>	1.0 mM	1.0 mM
D-GLUCOSE	11.0 mM	11.0 mM

was separated into two hemistruclures; and the superficial connective tissue, covering the muscle, was carefully dissected (Hasuo, personal communication).

### Perfusion

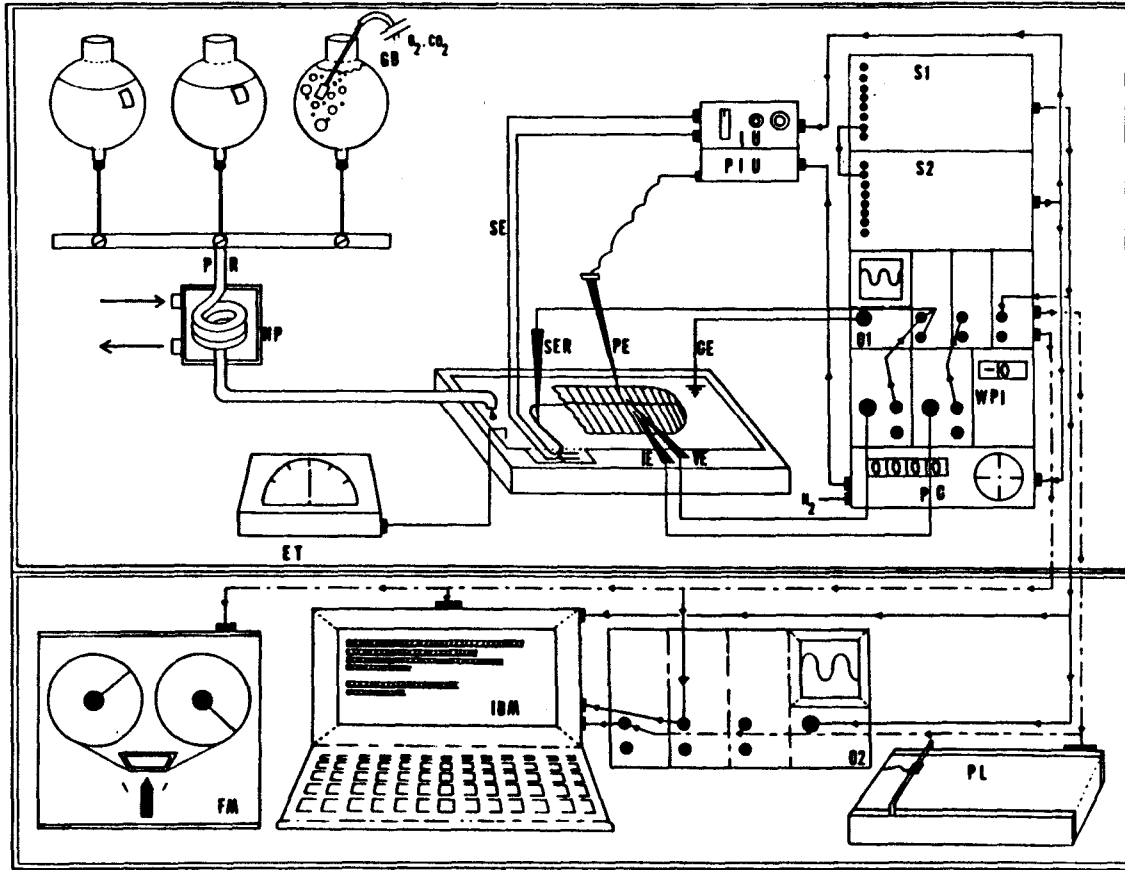
After dissection, the preparation was equilibrated in oxygenated (95% O<sub>2</sub>, 5% CO<sub>2</sub>) Ringer-Locke solution for 15 minutes. Following this time, the tissue was pinned into an experimental chamber, with a volume of approximately 2.5 ml. This chamber was continuously perfused at a rate of 3-4.5 ml/min. By warming the perfusing solution, the perfusate was maintained at 30° C. The drug containing solutions and ionically altered solutions were perfused by the same route (Table 0); a different reservoir (R) was used in each case. Solution types were changed by opening a different stopcock on the perfusion regulating system (PRS). (for a visual description, see the overall scheme.)

### Description of the Overall Experimental Scheme

To give the reader a general idea of the equipment layout, this schematic (Schematic 1) represents the whole recording system. The scheme can be divided into two portions: the top portion consists of the electronic equipment within the Faraday's cage. The lower portion mostly contains the monitoring and acquisition equipment outside the cage. The section within the cage, consists of

**SCHEMATIC 1**

Combination of all the experimental methods used in the present work. For a detailed description, see the text. For a description of the equipment and abbreviations, see the appendix.





a tissue bath which is perfused by oxygenated Ringer solutions of different composition. (see the section on the perfusing system). The perfusate's temperature is maintained by warmed water pumped through a chamber containing the coiled perfusate line (temperature chamber) The temperature is monitored by an electronic thermometer (ET) The center of the scheme is occupied by the tissue bath with a hemidiaphragm and phrenic nerve. The muscle is pinned to the bottom of the chamber lined with silicone (Elastomer by Sylgard). The nerve enters a stimulation chamber which is separated from the main muscle containing chamber by a silicone grease wall. The stimulation chamber contains two silver wire electrodes bathed in paraffin; the nerve is in contact with both wires. These two electrodes receive input from the stimulator, S-88, via the isolation unit (IU). The stimulation of the nerve is utilized in the EPP, EPC and CAP experiments. There are four glass electrodes shown in this scheme. The action potential recording glass electrode is shown abutting the phrenic nerve; the signal from that electrode is recorded by the differential amplifier of the oscilloscope and referenced to the ground electrode (CE) (for a detailed description of this recording, see the methods for the compound axonal potential). There are two electrodes inserted into the muscle cell: a voltage following, glass electrode (VR) and a current injection, glass electrode (IE). Both of these

electrodes are connected to the WPI-7000 mainframe. The WPI unit was used in all of the intracellular recordings, including the voltage clamp experiments. The (IE) was used in the voltage clamp experiments, as well as, the electrotonic potential experiments. The pressure ejection, glass electrode (PE) is the fourth electrode shown in the scheme. It was used in the ACh and carbachol potential experiments; it received pressure input from a pressure unit (PIU), which in turn received a command pulse of variable amplitude and duration from the main picospritzer module. The picospritzer is triggered by the S-88 stimulator. Monitoring and amplification of the physiologic signals for recording is done by oscilloscope (O1).

Outside of the cage, the system consists of a pen-recorder (PL), used for RMP monitoring; the oscilloscope (O2), for monitoring the physiologic signals outside the cage; an IBM-XT PC computer for data acquisition, storage and analysis; and a FM tape recorder (FM) for the storage of analog data. The broken lines leading from the "cage" are signal conducting lines and the solid line is a trigger signal. This pattern is followed in all the schematics.

#### General description of the Recording Systems

This electrophysiologic set-up consisted of a WPI-7000 mainframe with individual modules (see Schematic 1). One module, a WPI-S7071A, was used as a current pump in the

voltage clamp experiments, with a probe capable of passing 10 microamperes. This module also facilitated the recording of voltage changes. The second module, a WPI-S7050A, was a voltage follower with a differential amplifier. It was used in voltage recording experiments as well as in voltage clamp experiments. In the voltage clamp experiments, this module was used as a voltage sensor which then commanded the current pump to inject the current needed to follow the voltage. The third module was a S-7100A control module which allowed the measurement of electrode resistance at the tip. The resistance measurement was displayed on the digital screen. This also facilitated the measurement of the RMP by means of two different probes i.e., current and voltage probes. Besides voltage measurements, the current injected into a cell was measured by means of a digital current follower.

The Tektronix 5103N oscilloscope (01) was used for several purposes. First, it monitored the voltage change due to signal generation and the RMP. In compound action potential recording, it served as a differential amplifier. Finally, it served as an amplifier for the analogue plotter (PL), FM tape recorder (FM) and computer input.

Two Grass S-88 stimulators (S1 & S2) were used for (a) stimulation of the phrenic nerve via the isolation unit (IU), (b) triggering the computer, (c) triggering the oscilloscope, (d) pulse generation in the electrotonic

potential recording and (e) triggering the picospritzer. An electronic thermometer (ET) was used for continuous monitoring of the bath temperature.

## COMPUTERIZED DATA ACQUISITION AND ANALYSIS

### Data Acquisition Programs

This computerized system was IBM-XT PC based; (see Schematic 2) it consisted of two functional components: 1) an on-line acquisition system and 2) a data analysis system (see Schematic 2). Depending on the experiment performed, the on-line data acquisition system consisted of at least two channels of analogue input. For example, the "GET MEPP" program utilized the analogue input in such a way that after the input was converted to a digital signal by the Tecmar Labtender Board (A-D), the program continuously monitored the average baseline. The experimenter determined the threshold at which a given data sample was to be considered an mEPP. The threshold level was used as a trigger by the computer. An mEPP fulfilling the threshold requirements, would be considered as a data sample.

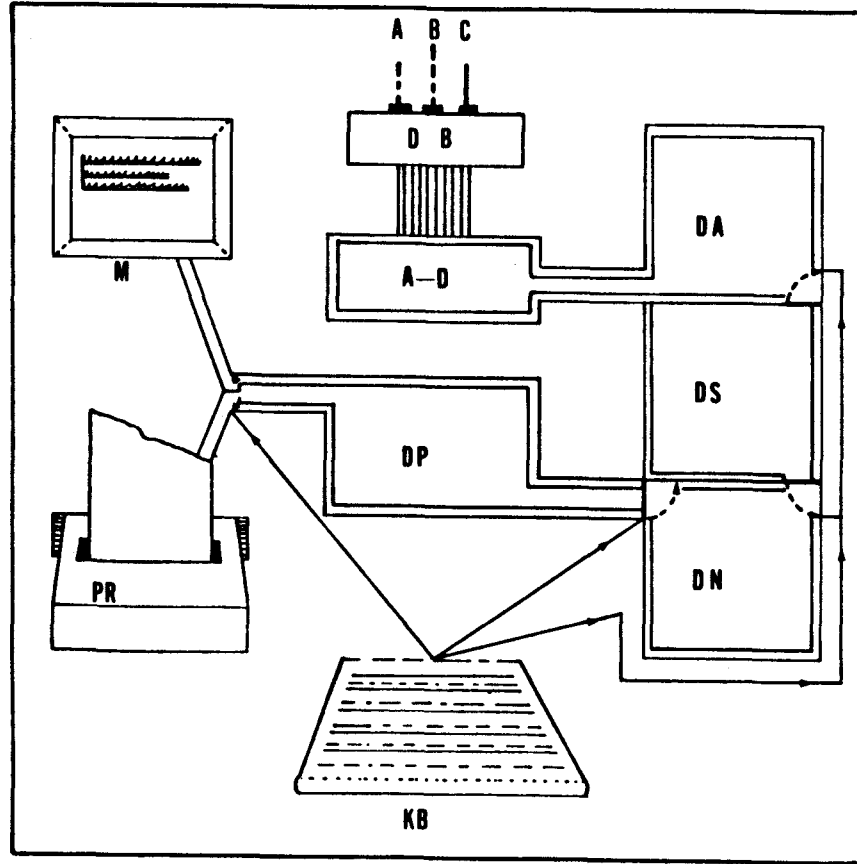
There are three evaluations performed upon this sample: 1) the amplitude of the sample was calculated as compared to the average baseline; 2) the number of events (mEPPs) was counted; and 3) the total waveform may have been saved. Each of these procedures was performed in five second intervals, at the end of which the data was stored into corresponding storage files. Each of these storage files was independent of the other with individually assigned addresses, i.e., "MEPPEVG.D" for the amplitude,

## SCHEMATIC 2

Data acquisition system based upon the IBM-XT PC. A, B & C represent inputs from the amplifier in the Faraday's cage. They carry trigger signals (solid lines), data signals (broken lines), such as the mEPP, EPP, EPC and DC data signals e.g., the RMP.

These signals enter the diode box (DB) containing Zenner diodes. The diodes eliminate signals greater than + 5V and prevent damage to the computer boards.

The A to D (A-D) is a Tecmar board, serving as an analogue to the digital converter. Digitization of the signal is under data acquisition control, which in turn is subordinate to the keyboard (KB) commands. Acquired data may be stored, analyzed and then, plotted. Plotting may be done on the Monitor (M) or on the digital printer (PR). The operation of the printer and the monitor are interdependent and controlled by the experimenter from the keyboard. The arrows leading from the keyboard to the interdepartmental transition gates represent the experimenter's control flexibility over the above mentioned processes.



"EPPCUT.P" for frequency and "MEPPAMP.D" for the whole waveform. Another type of input into the computer in this program is a DC input responsible for keeping track of the RMP. The RMP, in the other programs, was sampled every five seconds and its file (RMP.D) updated.

Another set of programs has been written to accommodate a collection of evoked responses. These are EPPs, EPCs, pressure generated potentials, electrotonic potentials, ACh potentials, carbachol potentials and action potentials. All of these programs utilize a trigger signal which allows the acquisition programs to be activated, i.e., to begin sampling. This trigger signal was a square pulse of at least 2 volts in amplitude and 1 millisecond duration, generated by a Grass S-88. The computer responds to the falling phase of the square pulse as the signal to start sampling from the physiologic signal channel. The delay adjustment on the Grass S-88 allows the manipulation of the response's appearance with respect to the time window so that the experimenter may eliminate stimulation artifact from a given sample.

There are two program types which may be used for the evoked response acquisition experiments: one is written in the computer language, BASICA and utilizes an 8 bit board; the other is written in APL and utilizes a 12 bit board. Because the BASICA programs were written first, the initial thesis work was done utilizing these programs. This



program, named EPX, was organized to collect the amplitude of a given waveform as compared to the baseline. This program provides an option that allows the investigator to collect the whole waveform for every specified time interval. The RMP was evaluated throughout the experiment. The interval at which the RMP was sampled was again, set by the investigator. The data storage was organized into three files with addresses: "control", "drug", "washout". During the experiment, one must change the data-flow from the control file to the drug file to the washout file.

Although the APL program (WORK2) was less complicated to use, it did not have the computer-analyzed RMP synchronized with the waveform acquisition; however, the RMP could be monitored by a pen-recorder or visual inspection of the digital output from the WPI-7000. In this program, the data were stored in one file; thus, the experimenter had to record the time of drug application, washout, etc. The advantage of this program was that it was very user-friendly and was very simple to run. Also, it gave one the option of either previewing data as it was collected or storing it automatically. One had the additional flexibility of analyzing the signals through a wide range of time windows, starting with 2.5 milliseconds/division extending through

minutes. The polarity of the signal was of no consequence; both positive and negative signals could be stored with equal ease.

#### Description of the Analysis Programs

The most comprehensive analysis system was written in BASICA, for this language is capable of plotting, by means of the TIMEGRAPH program, the response amplitude over time, the RMP over time (TIMERMP), the average collected waveforms (WAVERAGE) and calculating the 50% rise-time, and the 50% and 75% decay-times.

In the experiments in which the quantal content was measured, one of two methods was used, the failure or variance method, depending on the experiment (see below for details). In the case of the failure method, the quantal content could be calculated by the AMPEVOKE program. This program was later altered by employing a subroutine to calculate the quantal content by the variance method.

The mEPP programs were written in the language "C". The mEPP analysis programs were as follows: the AVGFRQPLT program plots the mEPP frequency collected during the five second intervals; it plots the frequency over time. The AVGAMPPLT allows for a plot of the average amplitude during the five second intervals, over time. Finally, the AVGRMPPLT displays the RMP, over time.

The APL programs were the most easily modified for experimental needs, making possible the analysis of positive and negative peaks. When these programs were used, either a single or an averaged waveform could be retrieved from the memory. Also, the data could be sent directly to the statistical analysis program which could perform a paired or unpaired Student t-test. Like the others, i.e. BASIC or "C", programs in this language are capable of plotting the amplitude over time. Here again, as in the C programs, it is up to the investigator to designate the times of different experimental phases.

## Description of the Statistical Analysis

The data were gathered via on-line analysis of a digitized signal. This signal was evaluated as to amplitude and waveform, as well as, the frequency, as in the case of mEPPs. This analysis was performed in designated time-windows, for example, 10 minutes in the case of EPPs.

The raw (unaveraged) data were temporarily stored in specifically designed bins of memory, addressed as "control", "drug" and "washout". Next, the data were transferred onto the floppy disc. From this disc, the data were analyzed, using programs developed in the experimenter's laboratory that allowed graphic interpretation. The flexibility provided by the graphic programs allowed the experimenter to interpret of the data in the average-over-time format: individual plots of amplitude over time, frequency over time, etc. were made for intra- and inter-experimental analysis.

First, we analyzed the data by comparing the control parameter to the PLC application parameter. Then, we calculated the percentage of change. These three pieces of information, i.e., the average control, the average PLC response and the percentage of change, were then included in a pool of other similar experiments. Statistical analysis was performed upon the pooled averaged control and the pooled averaged PLC response. The tables summarizing these results contain values for the pooled averaged control and

PLC effect from several different experiments. For evaluating the null hypothesis, we used the two-tailed, paired, Student t-test. The percentage of change was an average of the pooled data.

In a given experiment, the preliminary work allowed one to execute the Ruhling recommendations (Ruhling, 1980). The Ruhling recommendations state that at the onset of experimentation, one should choose the alpha and beta values. Then, after establishing the variance from the previous results, one can calculate the appropriate number (n) of experiments. These recommendations were followed throughout this project.

## GENERAL ELECTROPHYSIOLOGIC METHODS

## Microelectrodes

WPI, glass capillary tubes of two types were used; one had thick walls and a small opening with an outside diameter of 1.2 mm and an inside diameter of 0.58 mm. The other had thin walls and a large opening with an outside diameter of 1.0 mm and an inside diameter of 0.68 mm. It was found that the thick-walled microelectrodes were more useful for intracellular recording for they would penetrate the muscle membrane with greater ease, leading to more stable recordings.

Several methods were used to fill the microelectrode with 3 M KCl. Direct injection of 3 M KCl into a freshly pulled electrode was convenient, but frustrating: to extrude the bubbles, the electrode had to be tapped; this frequently ended in breakage (Ohta, personal communication). Since many electrodes had to be prepared at one time, boiling the electrodes in distilled water and storing them in 3 M KCl for equilibration proved to be time consuming (Nishimura, personal communication). Also, with time, boiled electrodes tended to become dull, leading to difficult muscle penetration. The most successful method, in the hands of this investigator, was to fill the electrode with distilled water via capillary action until the tip was full. The rest was filled with 3M KCl. Fifteen minutes of equilibration

was sufficient to have a sharp and bubble-free electrode.

The microelectrodes used for pressure ejection were filled with drugs by direct injection. All of the electrodes were pulled on a PN3 horizontal puller.

Intracellular electrodes, used in voltage and current recordings, had a tip resistance between 10-30 Mohms. The electrodes used in the current injection had resistances below 10 Mohms; the pressure ejection electrodes exhibited 1-5 Mohms of resistance. The extracellular electrodes, used for compound action potential recording, were made by pulling a high resistance electrode, (100 Mohms) and then breaking the tip. To ensure a controlled breaking process, the microelectrode was mounted in a micromanipulator and advanced against a glass shield until the electrode broke, the goal being to achieve a square-end microelectrode. Then, the electrode was finely polished in the electrode puller; the tip size could also be adjusted by repeated exposure to heat.

These methods of microelectrode preparation were employed in this laboratory, previously, and described in published papers (Schinnick-Gallagher and Jacobs, 1976; Ohta et al., 1981; Ohta and Karczmar, 1981).

#### Localization of Endplates

A Nikon microscope with an amplification of 80x gave little guidance as the density of endplates in close

proximity to axons is quite high. So, in that region, random penetrations were performed. A rise-time of 1 msec or less was used as the criterion for correct electrode positioning (Gallagher, 1972).



## Experimental Paradigm

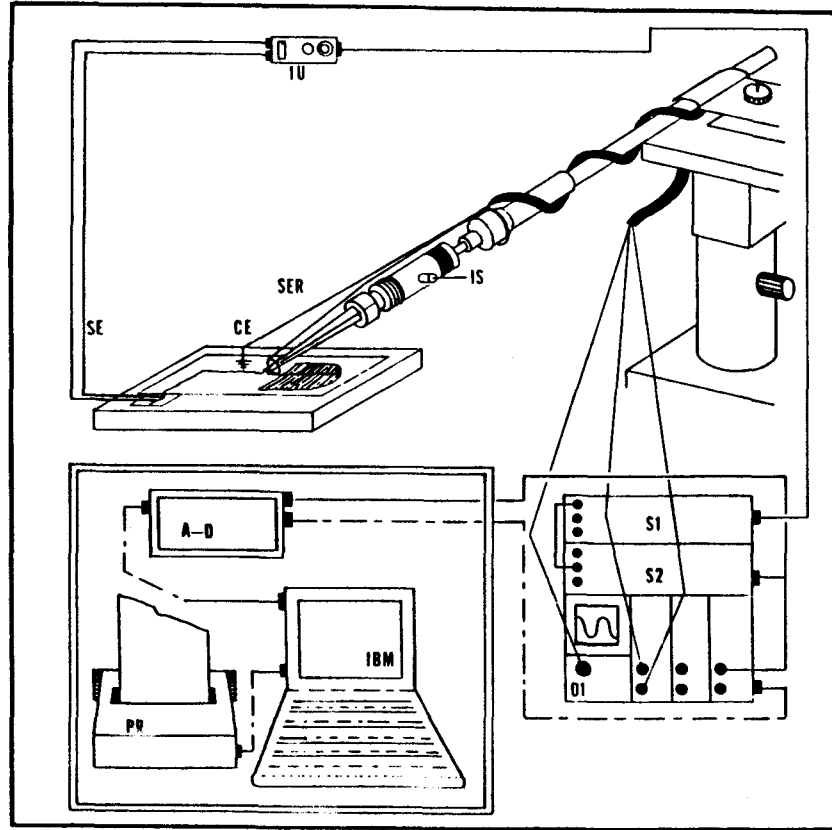
In each of the experiments involving intracellular recording, only the cells with a RMP more negative than -60 mV were used. Before recording the actual control, a period of 5 minutes was used. If the cell showed instability by a shifting RMP, the electrode was withdrawn and a new cell was located. The actual, recorded, control period was 10 minutes. The drug application time varied from 15 minutes, in the early phases of this work, to 30 min in the later phases. The reason for the change was twofold. First, in the experiments involving low  $Ca^{++}$ /high  $Mg^{++}$  in the presence of 0.1 u/ml of PLC, the stability of the cells was limited; one could rarely maintain a stable recording for longer than 20 minutes; however, this was possible in other experiments. Secondly, sometimes during the washout, a potentiation response, greater than that recorded during drug application, was observed; (see Results). In order to understand this phenomenon, the drug was applied for a longer length of time.

In general, the paradigm consisted of 5-10 minutes of control recording, followed by 15-30 minutes of drug application. In some experiments, when the cell remained

stable, recordings were performed throughout the washout period. Usually, however, fasciculations were observed, during the washout period, leading to dislodgement or displacement of the electrode.

**SCHEMATIC 3**

Recording of the compound action potential. For a detailed description, see the text.



## Recording the Compound Action Potential

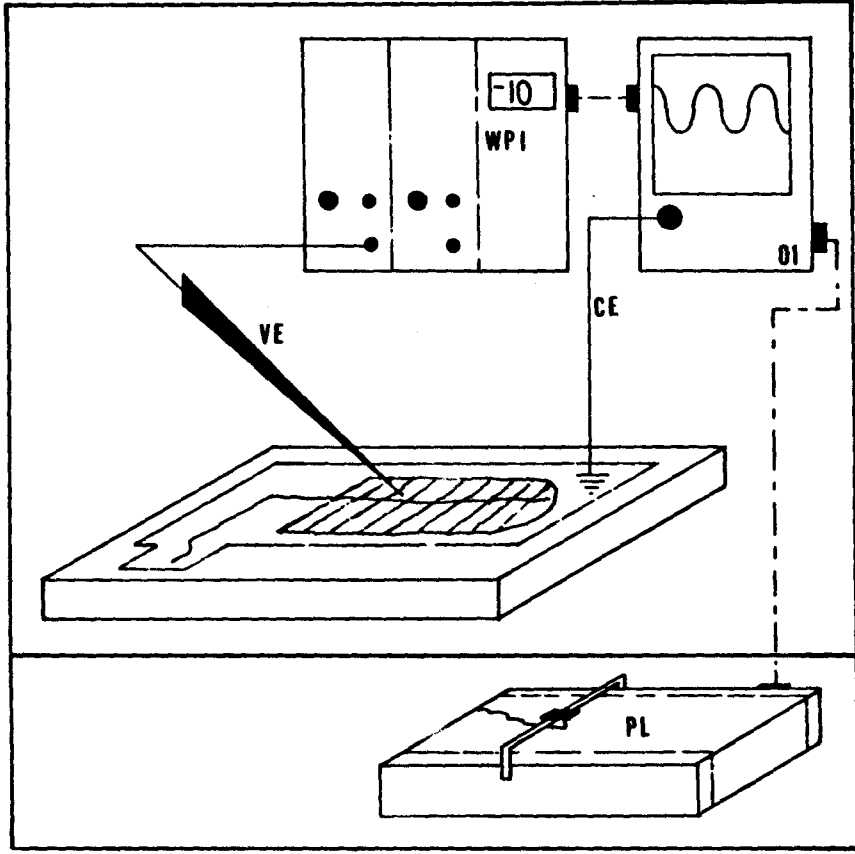
Several methods of recording the axonal action potential (AP) were utilized. First, an attempt was made to record the pre-junctional action potential together with the extracellular EPP, using the method described by Katz and Miledi (1965). In this method, KCl-filled electrodes with 5 Mohms resistance were placed at the endplate regions. The muscle was immobilized with 11 mM MgCl<sub>2</sub>, and the AP with the EPP wave recorded. However, this method was unsuccessful in generating any consistent response. A cut-muscle preparation was also tried, but was similarly unsuccessful. Next, a modified version of the Randic et al. (1964) method was tried; in this method, wire electrodes for both stimulation and recording were used. The electrodes were positioned in different locations on the nerve and separated from each other by silicone grease. In between the stimulating and recording electrodes, a ground electrode was located. Muscle contraction was inhibited by 3  $\mu$ M dTc. Although frequently successful, this method was unreliable and plagued with leakage of the Ringer solution along the nerve into the oil chamber, resulting in a large artifact.

Finally, the method of Jiang (personal communication) modified by the author, showed to be easy and very reliable. As shown in Schematic 3, the recording electrode included an electrode holder designed for the patch-clamp

technique. It consisted of an airtight electrode mounting which served as an outlet through which suction could be applied (IS). The electrode holder had a silver wire which entered into the electrode when the latter was in place. This wire was connected to the female portion of the electrode holder. On the outside of the electrode, another silver wire was looped 1.0 cm from the tip of the electrode. This wire was secured to the plastic body of the electrode holder so that it was electrically separate from the interelectrode wire. These two wires constitute the (+) and (-) inputs to the differential amplifier. A third wire, also silver and placed away from the two recording wires, served as a common ground (CE). The recording was done by sucking a portion of the nerve into the 1 mm glass electrode tip with a diameter approximately equal to the diameter of the nerve. To insure that the electrode did not injure the nerve, the tip was fire polished. The recording was done in a preparation where muscle contraction was prevented by transversely cutting the muscle fibers, in the presence of low  $\text{Ca}^{++}$ /high  $\text{Mg}^{++}$  and of 1-3  $\mu\text{M}$  dTc. The recording arrangement was as follows: the positive, negative and ground inputs were fed into a differential amplifier of a Tektronix oscilloscope, 5103N (01). This oscilloscope also served as an amplifier for the computer input (IBM-XT). After amplification, the signal from the recording electrode entered an A to D converter (Labtender by Tecmar) (A-D).

## SCHEMATIC 4

RMP recording by the pen-recorder (PR). The voltage recording electrode (VE) is positioned in the region of the endplate. The ground electrode (CE) is located in the bath. A WPI-7000 unit was used. An oscilloscope (O1) served as a monitor and DC amplifier.





Then after digitization, the signal was stored in the computer's memory for retrieval and analysis. Nerve stimulation was carried out by applying a square pulse three times above the threshold, with a duration of .01 milliseconds; a Grass S-88 (S1) was used. Generation of this pulse was triggered by another Grass S-88 (S2) which simultaneously triggered the computer program to sample the data and initiated the oscilloscope sweep to begin. The second stimulator facilitated the delay adjustment in sampling by the computer.

#### Recording the Resting Membrane Potential (RMP)

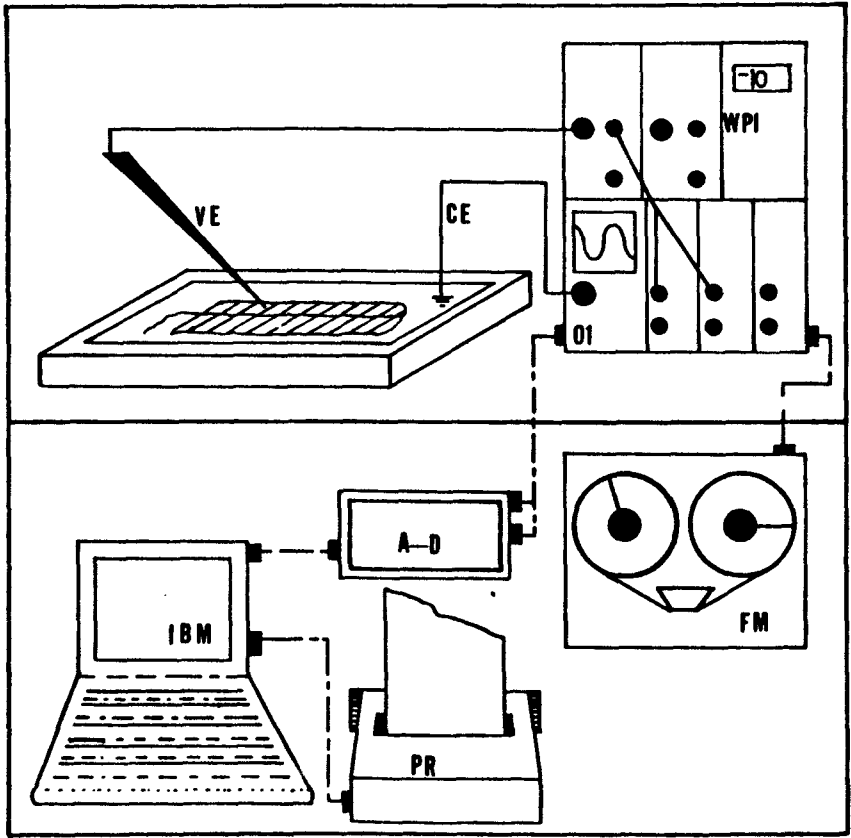
The resting membrane potential (RMP) was recorded by inserting an appropriate microelectrode into the junctional area. The location of the electrode relative to the post-synaptic membrane was verified by observing the mEPPs, as described previously. After establishing the stability of the cell's RMP, PLC perfusion was initiated; the concentrations ranged from 0.01 u/ml to 50 u/ml. The recording was performed by an analogue pen-recorder. Schematic 4 shows the recording set-up.

#### Recording the Miniature Endplate Potentials (mEPP)

The mEPPs were recorded with an intracellular electrode positioned in the endplate region, (see the General Methods for a detailed description.) Since the

## SCHEMATIC 5

Recording set-up used in the mEPP recordings. The microelectrode is located in the junctional region, facilitating RMP and signal recording. After being amplified (O1), the two signals enter the IBM's AD board; after these signals are converted to digitized signals, they are stored on the disc. The mEPP signal also is stored in its analogue form on tape by the Velter FM tape recorder (FM). After the experiment, the signal was re-played into the IBM for repeated analysis. Analysis of the data was performed after each experiment.



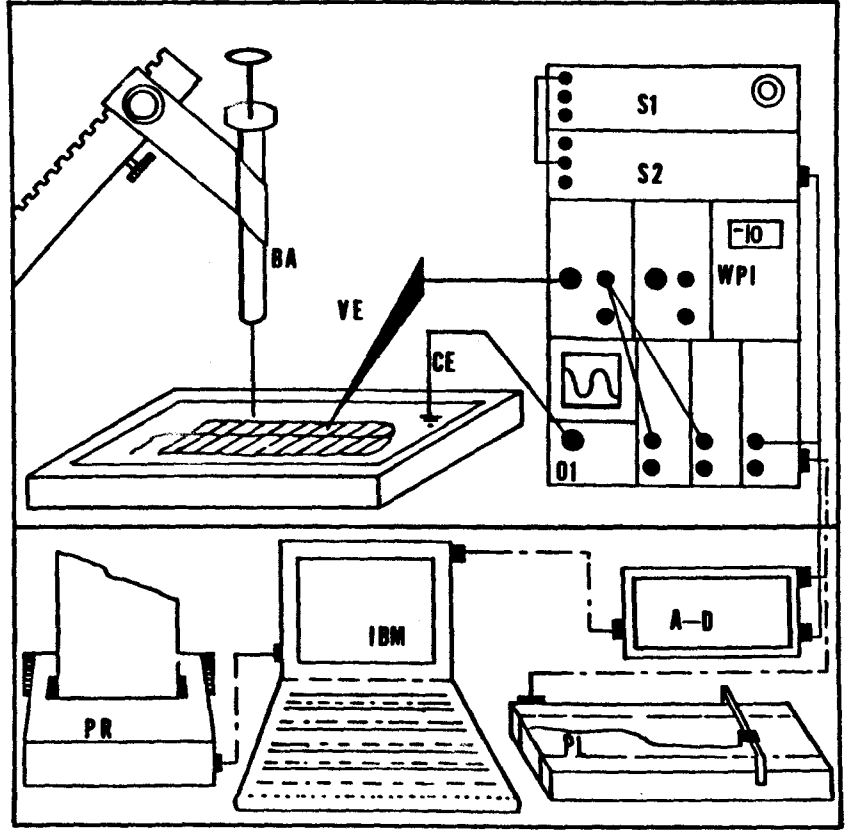
amplitude of mEPPs was generally around 1 mV and because the computer program used to acquire data was triggered by the threshold set by the investigator, it was important to have a recording relatively free of baseline noise. This was accomplished by selecting an electrode with a sharp tip and relatively low resistance. By doing this, it was possible to reduce the noise level to about 5-10% of the signal, thus allowing for a threshold setting at about 65% of the signal. In the few cases where the noise level changed during the experiment, the threshold could be readjusted. However, if there was an apparent shift in the computer-recorded frequency and/or if the amplitude was in conflict with the investigator's observations, the experiment was re-entered into the computer from the FM tape recorder, used as a back-up system, and the two recordings were compared. However, in the case of this work, only one experiment had to be re-evaluated. The schematic of the recording set-up is prepresented in Schematic 5.

#### Recording the Endplate Potential (EPP)

EPP analysis was performed in two different Ringer solutions. One solution contained a high  $Mg^{++}$  (11 mM) and a low  $Ca^{++}$  concentration (.1 mM), the other contained dTc, 1-3  $\mu M$ . The recording set-up was similar to that used in the Quantal Content Analysis. An acquisition program written in BASICA was used. The individual waveforms were collected

## SCHEMATIC 6

ACh potential by bath application. Immediately prior to ACh injection, the experimenter presses a manual trigger on the S-88 to initiate the recording through the voltage recording electrode (VE). The signals (EPPs & RMPs) are seen on the oscilloscope screen. After amplification, the signal travels to an A to D board; it is then stored on the disc and/or printed. The RMP is monitored by the pen-recorder and the digital read-out from the WPI-S7100A.



every minute; thus, 10 waveforms were collected during the control period and 30 during PLC application. The rate at which the computer sampled the waveforms was dependent upon the memory available for this specific function. The waveforms were analyzed as to their amplitude, rise-time and 50%, as well as, 75% decay-times. Failures occurred in the experiments where low  $\text{Ca}^{++}$ /high  $\text{Mg}^{++}$  were used. Since the computer program for the analysis of the EPP amplitudes was unable to eliminate these failures, a histogram program was written. This program's function was to plot the number of EPPs as related to their amplitude (histogram). This program also gave a qualitative and quantitative indication of whether or not the amplitude of the EPPs changed in the presence of high  $\text{Mg}^{++}$  and low  $\text{Ca}^{++}$ , during PLC application. In a solution containing dTc, the recording of EPPs was carried out as described above; the only difference between the two experiments was that the latter did not contain failures.

#### Recording the ACh Potential

The evaluation of the ACh potential is useful for recording a post-synaptic response and evaluating endplate sensitivity without involving pre-synaptic structures. There are several ways which this response can be elicited. Bath-applied ACh leads to depolarization. This approach was tried; but, probably due to desensitization, it

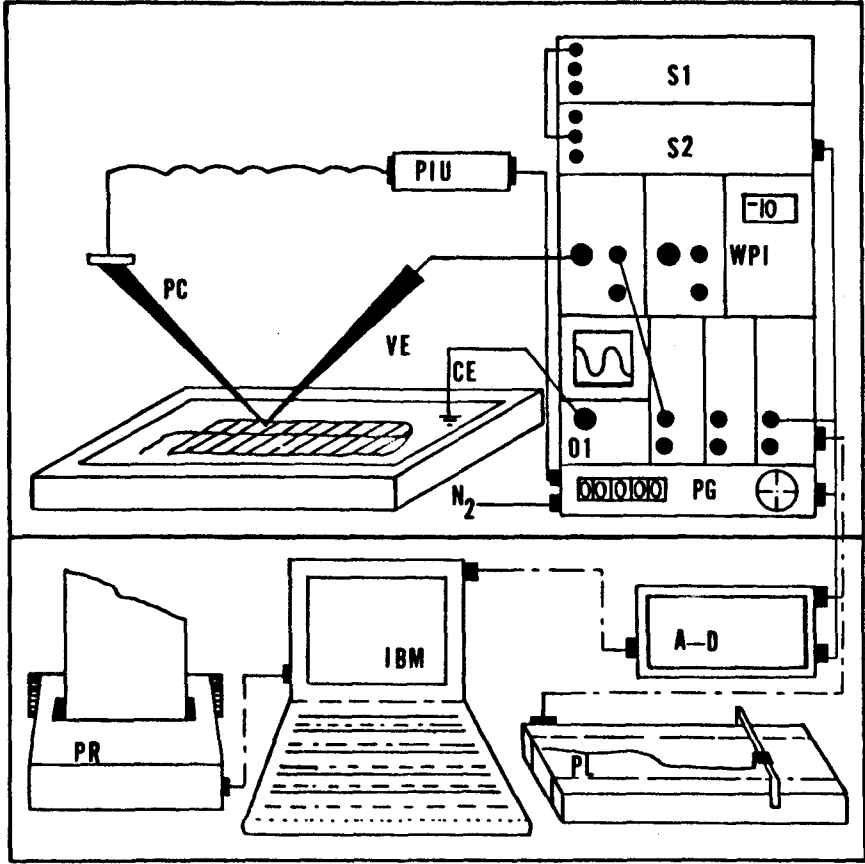
was found that consistent recordings were difficult to obtain. A modified method used 0.1 M ACh dissolved in Ringer solution injected directly into the bath. This injection was performed manually by a microliter syringe positioned in a given area of the bath by means of a micromanipulator. The positioning of the syringe did not change, nor did the volume injected; the only variable was the pressure with which ACh was ejected. Even that parameter became constant with practice. This method was found to be more successful in obtaining consistent responses. Ultimately, the concentration of ACh used varied from 0.1-0.05 M. After localization of the endplate by the mEPP rise-time criteria (Gallagher, 1972) and stabilization of the RMP, ACh was injected into the bath, starting with a low concentration that was gradually increased to where a response was recorded without generating a muscle contraction. Consecutive injections were separated by 10 minute intervals of wash. Upon obtaining a set of two good, control recordings, PLC perfusion was initiated; another set of injections followed. As in the compound action potential recordings, the data were collected by an APL program. Just prior to the injection of ACh the experimenter initiated the recording (see Schematic 6).

Iontophoretic application of ACh was attempted; but the success was minimal. It was difficult to get close enough to the junctional region to generate a consistent



## SCHEMATIC 7

Acquisition of ACh and carbachol potentials. Microejection is done by a "Picospritzer I" by General Valve Corporation, for the ejection through the pressure ejection electrode (PE). This unit utilizes  $N_2$  as a gas source. The Picospritzer is triggered by a square pulse of 1 ms duration and 5 V amplitude generated by the Grass S-88 stimulator (S1); the other channel of the S-88 stimulator is used for the computer trigger. Both channels are synchronized and triggered by a second Grass S-88 stimulator (S2). The other arrangements were similar to those in both applications of ACh.



potential. A variety of ACh-containing electrodes were tried, as well as, two different means of injection: an iontophoretic unit and two Grass S-88s were used for retention and ejection currents.

The most successful method utilized the "picospritzer" (pressure ejection) for microejection; it has been suggested that this method is more predictable than the iontophoretic method in terms of quantitative delivery (Woody et al., 1979).

The ejection electrode was pulled with a tip resistance of 100 Mohms. Then, controlled breakage of the electrode tip was performed. The electrode was filled with 0.01 M ACh. The placement of the electrode was controlled by a micromanipulator. As described previously, the endplate region was localized. Then, the ejection electrode was positioned in close proximity to the recording electrode. If due to leakage of ACh, depolarization was observed, the electrode was changed. The amount of pressure used for ejection remained constant; the ejection duration varied. The goal was to obtain a sizable response without the generation of a muscle twitch. The programs used for acquisition and analysis of the data were written in APL (for the recording, see Schematic 7)

## Recording the Quantal Content

In this thesis, two methods were used to evaluate the quantal content: the failure method and the variance method. The following is a short description of the theoretical background for each of these methods.

The empirical observations were carried out by del Castillo and Katz (1954), leading to the quantal hypothesis. They demonstrated that the endplate potential can be reduced to a unit identical to the mEPP. This was accomplished by increasing the  $Mg^{++}$  and decreasing the  $Ca^{++}$  concentration in the perfusing solution. By analyzing the amplitudes of these responses, it appeared that they were distributed in such a way as to be described by the Poisson distribution expression. This expression is a special case of binomial distribution. In this case, although the number of release sites ( $n$ ) is large, the probability is small that a single quantum ( $p$ ) will be released. The average quanta released ( $m$ ) per trial is then described by the equation:

$$m = pn$$

The rule of thumb describing this relationship is:

$$p \leq 0.05 \text{ and } n \geq 100$$

(Junge, 1981).

The failure method of calculating quantal content is restricted to the conditions described above, i.e., in the perfusate, transmitter release has been inhibited by low  $Ca^{++}$  and high  $Mg^{++}$  concentrations. Where  $m$  is the mean

number of quanta liberated by an impulse, the probability of an EPP occurring with (x) quanta is given by the equation:

$$P_x = e^{-m} m^x / x!$$

A direct method of quantal content estimate (m) may be represented as follows:

$$m = \text{EPP amplitude} / \text{mEPP amplitude}$$

With 0 quanta or failures, the probability of an EPP occurring can be expressed as:

$$p = e^{-m}$$

By solving for m, one obtains:

$$m = \ln(N/N_0)$$

This expression was described by del Castillo and Katz (1954). If the Poisson relationship held, then:

$$m = \text{EPP amplitude} / \text{mEPP amplitude} = \ln(N/N_0)$$

The latter equation was used, in this dissertation, for the quantal content estimate by the failure method.

In the experiments in which dTc was used to prevent muscle contraction, the variance method of quantal analysis was employed (Warnick et al., 1978). As in these experiments, it was impossible to use a direct method of measurement because of the EPP suppression by dTc and the

inability of the acquisition program to perform simultaneously both mEPP and EPP collection.

The variance method is based on the assumption that the variance of the EPP (VEPP):

$$VEPP = EPP = SD^2$$

where:

$$SD = \sqrt{VEPP}$$

Thus, the coefficient of the variation (CV):

$$CV = \sqrt{VEPP}/EPP$$

Then:

$$CV = SD/EPP$$

By definition, (see also del Castillo and Katz, 1954c) the quantal content of the EPP is:

$$m = 1/CV^2$$

(del Castillo and Katz, 1954c).

This, of course, is an indirect method of estimation and is subject to more error than the direct method; however, by using a larger number of samples (greater than 100) the estimate improves (Boyd and Martin, 1956).

With high amplitude EPPs, the proportionality between the quantal content and the amplitude becomes less linear (Martin, 1966). This problem can be solved in two ways: The amplitude correction factor derived by Martin (1955) may be used or sufficient concentrations of dTc can be employed to prevent the mean amplitude of EPPs from surpassing approximately 5 mV, the point of non-linearity. The latter solution was employed in this work.

In order to test the Poisson versus the binomial-type of distribution, one must collect mEPPs and EPPs from the same junction, followed by the calculation for p and n. This, then, will facilitate the analysis of the quantal distribution by the Chi square test. If the experimental distribution is the same as the one predicted by the distribution of Poisson release, then one can be confident of the assumption. The method for testing the binomial versus Poisson distributions is described by Johnson and Wernig (1971). Briefly, m is estimated by the equation:

$$m = \text{total number of quanta released/number of trials.}$$

Where mEPPs and EPPs are recorded (low Ca<sup>++</sup>/high Mg<sup>++</sup>) for the binomial calculation, the probability of release can be determined by:

$$p = 1 - \delta^2/m$$

$\delta^2$  = the variance of a series of (N) trials.

n = readily releasable stores and can be calculated by:

$$n = m/p.$$

The number of failures (no) predicted by the binomial distribution is:

$$no = N - (1 - p)^n$$

To calculate the number of responses in the bins of 1, 2 and 3 quanta, etc. as predicted by binomial distribution, one can use:

$$n_x = m_x - 1 [m - p(x - 1)/x(1 - p)]$$

where  $n_x$  represents the frequency of each x value, i.e.,  $x_1$ ,  $x_2$ ,  $x_3$ , etc., during a series of trials (N). In the Poisson distribution, the number of failures (no) can be calculated by:

$$n_0 = Ne^{-m}$$

while the frequency of each x value during N trials can be calculated:

$$n_x = n_x - 1 (m/x).$$

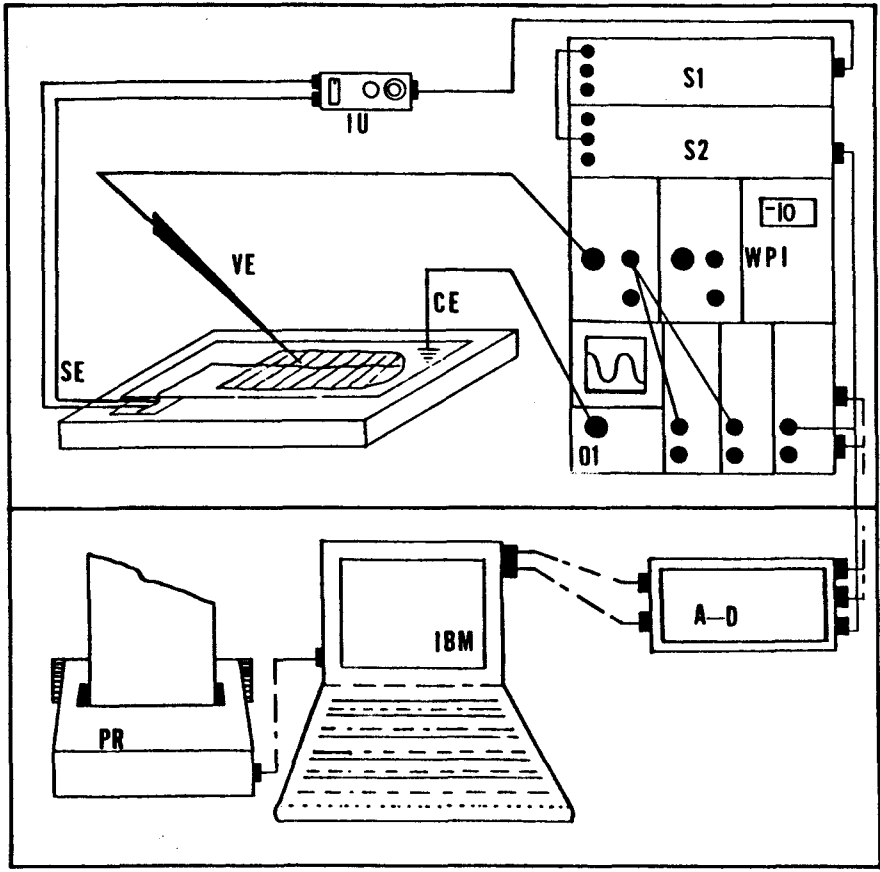


The choice of methods used for (m) estimation was based upon the need to be consistent with the methods of Ohta and Karczmar (1981) so that the results from the amphibian and mammalian preparations could be compared. In this dissertation, the methods used for estimating the quantal content depend upon the assumption implied by the Poisson-type distribution of neurotransmitter release at the neuromuscular junction under study. The transmitter release may be better described by the binomial distribution, in which case the significance of the results, although not exact, may be attributed to the real difference in (m) (Tiedt et al., 1978, Warnick et al., 1978).

Since the phrenic nerve-diaphragm preparation is frequently used for electrophysiologic studies, including quantal content analysis, the Poisson distribution assumption is well accepted (see Beranek and Vyskocil, 1966; Banker et al., 1982). The author could not perform the Johnson and Werning test for binomial versus Poisson distribution for two reasons: It was difficult to record the mEPP and EPP in dTc half-block Ringer solution because the amplitude of the mEPPs was lost in base-line noise. Also, the on-line computer acquisition system was incapable of simultaneously recording mEPPs and EPPs. The test's prerequisite for estimating (m) is the simultaneous recording of EPPs and mEPPs.

## SCHEMATIC 8

Quantal Content and EPP recording. The signal generated by the Grass S-88 (S1) results in a recording of the EPP. The EPP, together with the RMP signal, is amplified by the oscilloscope 5103N (01). The Tecmar A to D converter facilitates computer acquisition and analysis. The hard copy of the data is acquired by a dot matrix printer (PR). The S-88 (S1) also serves as a trigger for the oscilloscope and computer.



The recording system consisted of an electrode inserted into the junctional area, the criteria for which have been described earlier. The perfusion of either high  $Mg^{++}$ /low  $Ca^{++}$  or dTc was initiated. Generally, 15 minutes of perfusion was sufficient to prevent muscle contraction. If during perfusion, the electrode was dislodged due to a muscle twitch, the EPP waveform was used as the criterion for junction location in the dTc experiments. As described earlier, the phrenic nerve was stimulated by a square pulse. The waveform data and RMP data were amplified by the oscilloscope amplifier, Tektronix 5103N (01), and digitized by a Tecmar A to D converter. BASICA programs were used for the acquisition and analysis of the waveforms (see Schematic 8).

The failure method experiments were analyzed by a program which identified the total number of trials in each bin, i.e., "control", "drug" and "wash". Depending on the waveform of the signal following the trigger pulse, it was possible to identify either an EPP or a failure. The data were stored for calculation of (m) according to the formula:

$$m = \ln(N/N_0)$$

The variance method program used a variable bin according to the time established by the experimenter. Since the control period was 10 minutes long, the data were

analyzed in 10 minute bins. The experimenter was interested in the period of peak drug effect; then, that period of time was used in the pooled data analysis (see the section on statistical analysis). The peak drug effect was identified by an amplitude change in the EPPs. The variance method data were acquired in the same way as in the failure experiments; the formula used for m calculation was:

$$m = 1/CV^2$$

#### Recording the Carbachol Potential

The carbachol experiments were performed by microejection of the drug into the junctional area. The ejection, recording and analysis systems were the same as in the ACh potential experiments. The ejection electrode was filled with 0.2 M carbachol; after establishing a stable recording, the experiment was initiated.

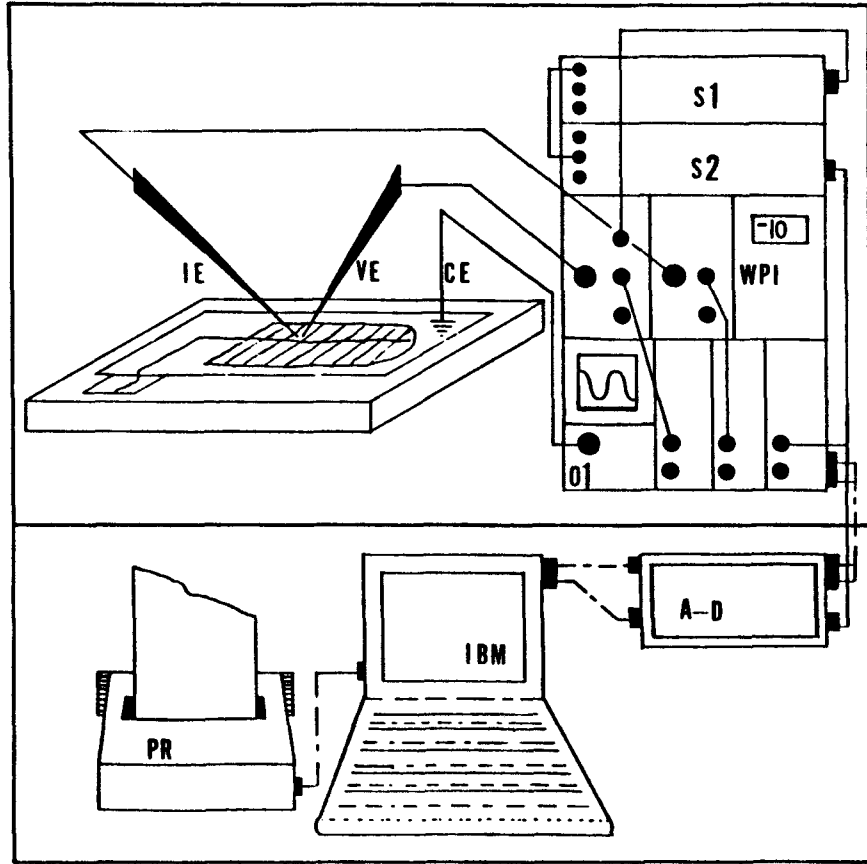
#### Recording the Electrotonic Potential

The measurement of the post-synaptic membrane's passive properties was similar to that carried out by Gallagher et al. (1976). Two electrodes were inserted into the same muscle cell. Their position in relation to the junctional region was established by recording mEPPs from both electrodes on separate channels of oscilloscope (01) (see the overall schematic). The criteria, for acceptable

placement of the electrodes, were the same as those employed in the mEPP studies. One electrode was used to monitor voltage, whereas the other was used to inject current. Generally, as the second electrode was introduced into the cell, the RMP decreased by 5-15 mV. Upon establishment of the cell's stability, as described previously, the recording was initiated (Schematic 9 shows the recording set-up).

## SCHEMATIC 9

Electrotonic potential monitoring. Electrode (VE) is used for the voltage recording, whereas electrode (VI) is used as a current injection electrode. An S-88 (S1) stimulator was used for the square pulse injection into the module, resulting in a linear amount of current. Another S-88 (S2) was used for a synchronized triggering of the oscilloscope and the computer. An APL program was used for collection and analysis of this data.





The current injected was linear with the voltage applied to the external input in the S-7050A module; it was monitored on oscilloscope (01). The second trace, the electrotonic potential trace, was recorded by the APL acquisition and analysis programs. Current tracings were not stored. The RMP of the cell was monitored by the pen-recorder.

### Voltage Clamp

There are several electrophysiologic methods used to evaluate synaptic currents. These are: concentration jump relaxation, i.e., EPC or mEPC; voltage jump relaxation; noise analysis and patch-clamp single-channel recording. All of these techniques have their advantages and drawbacks. Briefly, voltage jump relaxation is based upon the observation that the amount of current flowing through a membrane depends upon the agonist concentration and the membrane potential. At a given constant concentration of agonist, when the membrane potential is decreased (hyperpolarized), there will be an increase in the inward current and in the outward currents during the decay-time. The net current flow will depend upon the change in the driving force, as well as, upon the net time during which the channels are open. During the voltage jump, the decay-time is used as a measure of the mean open-channel lifetime. The problem with this technique is that one must

be concerned with the concentration of the drug in the synaptic region; a level that is too high may complicate the kinetics of the channel activity, namely, opening rates may interfere with closing rates. Desensitization may also play a role.

The noise analysis method was developed based on a discovery by Katz and Miledi (1970). They found that ACh applied to the neuromuscular junction increases the "noisiness" during depolarization. They ascribed this phenomenon to random channel activity. By recording current in the above situation and then subjecting it to Fourier analysis, one is able to plot spectral density in terms of the frequency. At low frequencies, the plot is flat and at high frequencies, it drops; at the point of the drop, the frequency ( $f_c$ ) is related to the half-life of the channels ( $\tau$ ) by:

$$\tau = 1/2 f_c$$

(Anderson & Stevens, 1973)

This analysis also provides an estimate of single channel conductance ( $\gamma$ ) by using:

$$\gamma = \text{Var} (I) / u_1(V - V_{eq})pT$$

(Anderson & Stevens, 1973)

where:

VarI = variance of current fluctuation about the mean.

U<sub>1</sub> = mean current induced by a drug at the holding potential V.

V = holding potential.

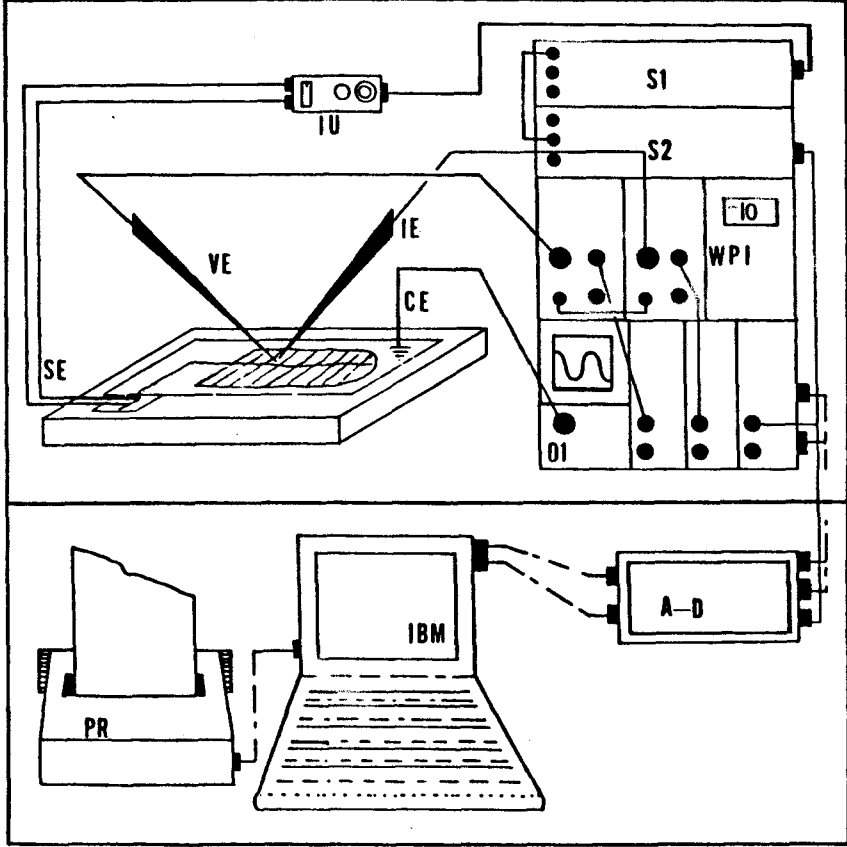
V<sub>eq</sub> = Equilibrium Potential for the drug.

pT = the fraction of the closed channels (it increases with an increase in the drug concentration).

Because it utilizes a small patch of membrane sealed at the tip of the recording electrode, the patch clamp technique allows for the recording of single channel activity. By filling the pipette with agonist, one can measure currents generated by agonist/receptor interaction. The duration of these currents is related to the lifetime of the given channel.

## SCHEMATIC 10

Voltage clamp experiments. This schematic is basically the same as the electrotonic potential schematic except for the feedback (V-clamp) amplifier and nerve stimulator.



This work employs the concentration jump relaxation technique, where a sudden increase in agonist concentration results in synaptic current flow. The duration of this current flow is related to the lifetime of individual channels. These channels will stay open for a random, exponentially distributed period. The rising phase of current represents a number of channels opening as a function of time. The falling or decay-phase represents the distribution of closing channels. The exponential time constant ( $\tau$ ) is thus a representation of the mean channel, open-time. This hypothesis has been supported by independent techniques, such as, noise analysis and patch clamp recordings (Anderson & Stevens, 1973; and Neher & Steinbach, 1978). In order to avoid problems with agonist diffusion into the recepto-ionic channel site, the pressure ejection, EPC method was used.

Two modules of the WPI-7000 mainframe were used for the voltage clamp experiment (see Schematic 10). The S-7050A module was used as a voltage monitor; its function was to sense the intracellular potential and compare it with the command provided. For example, when an EPP was generated by stimulation of the phrenic nerve, the change in voltage was sensed and applied to the negative feedback amplifier. Amplified, this difference was applied to the second module S-7071A which served as a current pump. The current was measured and recorded. In these experiments, the cell's RMP

was held at -65 mV. The impaling technique was the same as described previously with regard to the methods employed in recording the electrotonic potential methods. After the stability of the cell was established, the clamp circuit was activated and the negative feedback was increased to the point where the EPP voltage was reduced to 80-90% of its control value. The negative feedback was increased as far as possible without provoking oscillation. The speed of the current response was also adjusted. This was done by means of the negative capacity adjustment; this adjustment was made judiciously to obtain as fast a response as possible without producing ringing (Linder & Quastel, 1977). The acquisition and analysis data programs were written in APL.

## RESULTS

### Compound Action Potential

The purpose of these experiments was to analyze the effect of PLC upon the axonal action potential as expressed through the measurement of the compound action potential. It is assumed that in the event that PLC alters the axonal conduction, there will be a change significant enough to be observed via the compound action potential. The compound action potential was measured in a variety of preparations. In these preparations muscle contraction was blocked by (1) the cut-muscle method (Barstad & Lilleheil, 1968), (2) dTc half-block and (3) magnesium block. The experimenter's aim in using these three approaches was to eliminate the possible differential PLC effect by employing varied experimental conditions. Figure 1 shows a typical compound action potential. The first plate (A) shows a compound action potential (CAP) with an observable muscle twitch. The second plate (B) shows a CAP when exposed to dTc, 3.0  $\mu$ M. This is followed in (C), by the application of tetrodotoxin (TTX), 20 nM. Total inhibition of the CAP by TTX is seen. As would be predicted, the CAP was sensitive to the stimulation intensity; but, there was no great variation in its amplitude when the intensity was varied from the threshold level to three times that level.

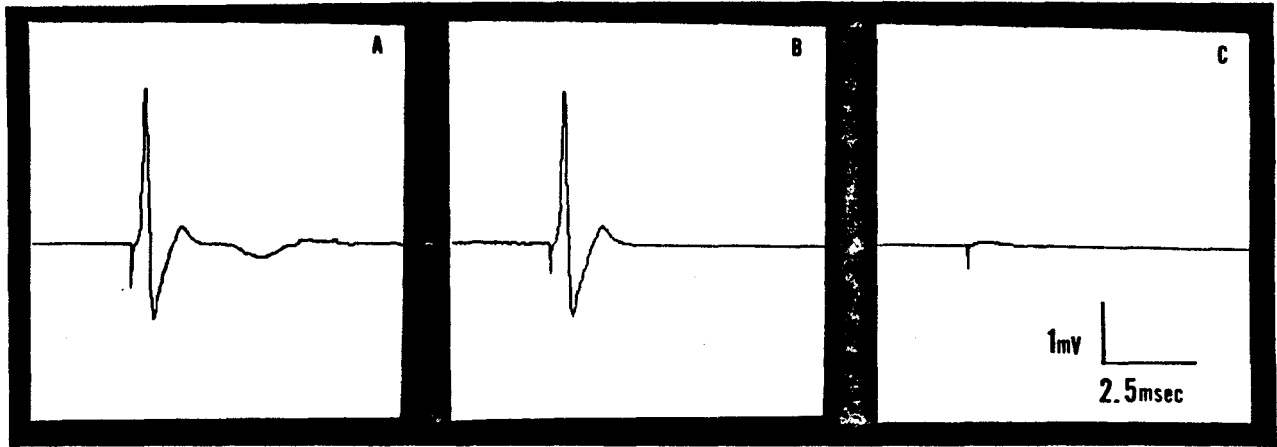


in terms of its axonal type. In the preparations of cut-muscle, curarized muscle, and  $Mg^{++}$  blocked muscle, the application of PLC (.1 u/ml) did not show any significant effect upon the CAP. The washout phase of these experiments was also unaltered, as shown in Figures 2, 3 and 4.

## FIGURE 1

Recording of the compound action potential.

- A - Control recording with the muscle twitch present.
- B - Recording of the same potential with 3  $\mu$ M dTc.
- C - Recording after perfusion with 20 nM TTX.



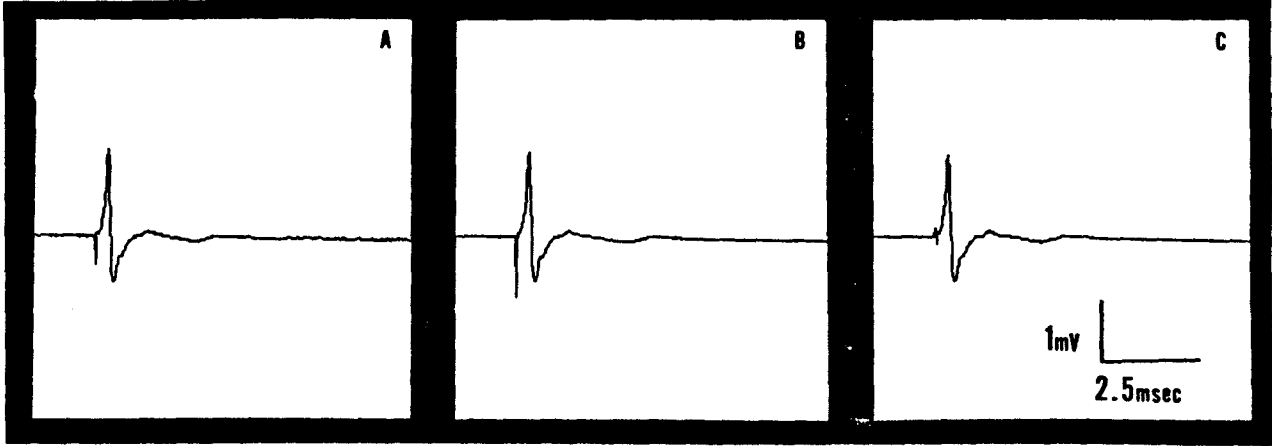
## FIGURE 2

Recording of the compound action potential in the cut-muscle preparation.

A - Control recording.

B - Recording at the end of the .1 u/ml PLC perfusion period (30 minutes).

C - Recording at the end of the washout period (30 minutes).



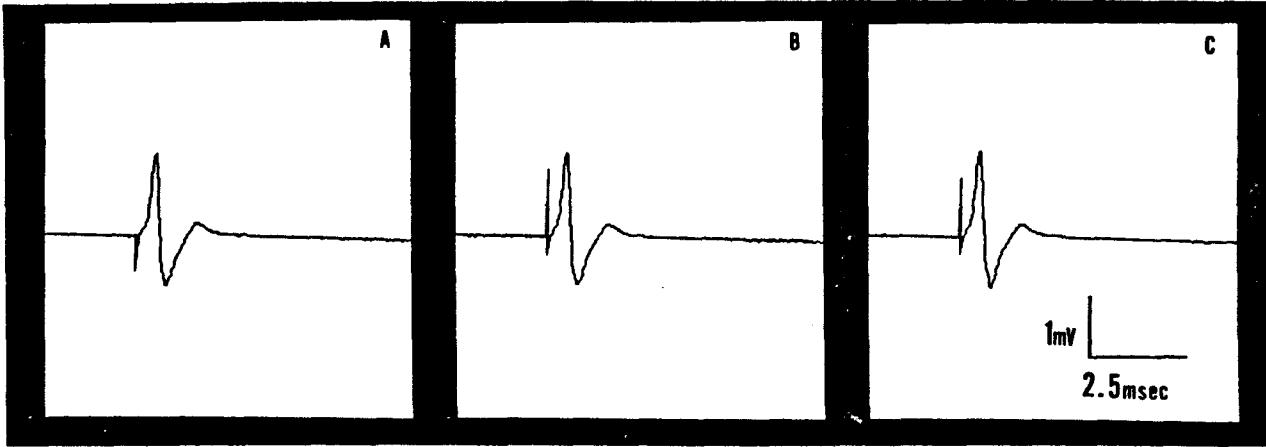
## FIGURE 3

Recording of the compound action potential in the dTc half-blocked (3  $\mu$ M) preparation.

A - Recording of the control period.

B - Recording at the end of PLC .1  $\mu$ /ml application period (30 minutes).

C - Recording at the end of the washout period (30 minutes).



## FIGURE 4

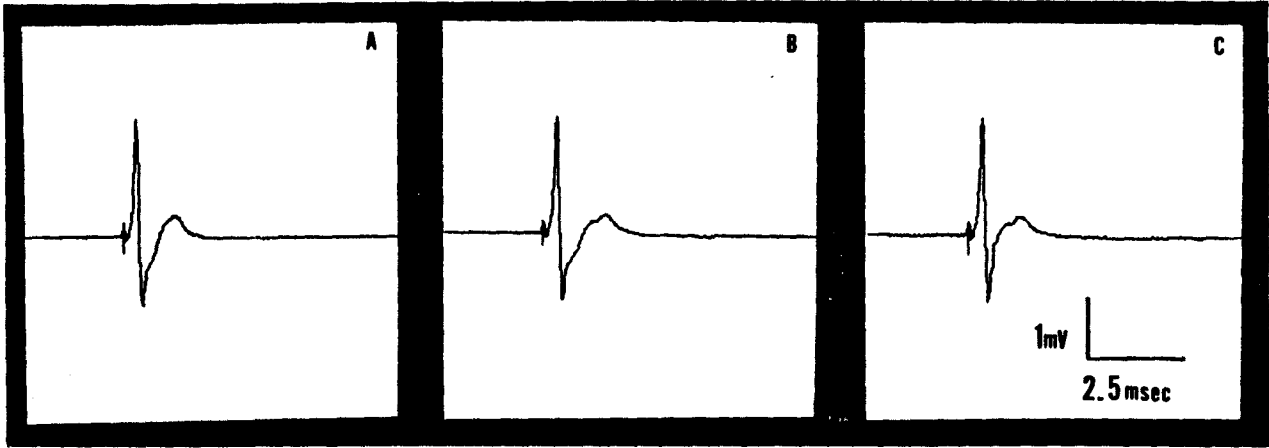
Recording of the compound action potential in the altered Ringer solution (low  $\text{Ca}^{++}$ /high  $\text{Mg}^{++}$ ).

A - Recording during the control period.

B - Recording at the end of PLC application (30 minutes).

C - Recording at the end of the washout period (30 minutes).





These experiments, demonstrate that PLC in concentrations of .1 u/ml (which proved effective in creating an action on neuromyal transmission; see below) has no effect upon the amplitude or configuration of the CAP. These data are in agreement with those of Rosenberg (1970), who found that despite releasing from 85-100% of phosphorylated bases, by means of 40-50 u/ml of PLC from Clostridium welchii, there was no effect upon axonal function.

The figures also show that the conduction velocity does not appear to be changed. However, the greater the resolution in time, the more apparent the difference might become. Unfortunately, this recording system was unable to facilitate that analysis.

#### Resting Membrane Potential (RMP)

PLC was used in different concentrations, ranging from 0.01 u/ml to 50 u/ml, to establish its effect upon the RMP (Figure 5).

## FIGURE 5

Analogue plots of the RMP in different concentrations of PLC. The arrows indicate the onset of perfusion with PLC.

A - Tracing of the RMP where 50 u/ml of PLC was applied. One observes depolarization followed by the loss of the cell (n = 4).

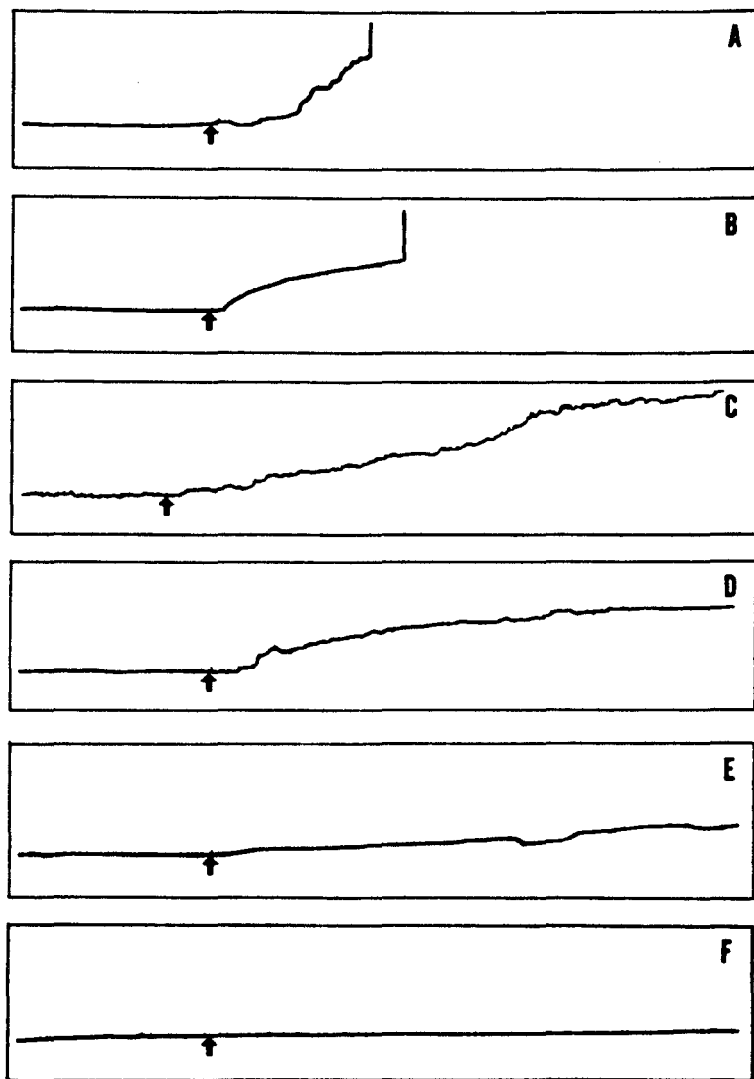
B - Tracing of the RMP where 25 u/ml of PLC was applied. Depolarization is observed followed by the loss of the cell (n = 3).

C - Tracing of the RMP where 10 u/ml of PLC was applied. Depolarization did not result in the loss of the cell (n = 3) for the duration of the experiment.

D - Recording of the RMP where 5 u/ml of PLC was applied (n = 3).

E - Recording of the RMP where 1 u/ml of PLC was applied (n = 3). There is some depolarization.

F - RMP recording where 0.1 u/ml of PLC was used. No apparent depolarization was observed (n = 3).



10mv |  
2min

It was important to find a concentration of PLC which would exert a minimal effect on the RMP and yet have an effect upon synaptic events, e.g., the mEPP frequency. Since the goal of this study was to evaluate synaptic events, it was important to eliminate as many variables as possible; thus, the investigator's concern with RMP instability resulting from drug application. It was found that 0.01 to 0.1 u/ml concentrations of PLC had a minimal effect upon the RMP. However, concentrations below 0.1 u/ml showed no significant change upon other parameters, such as the mEPP frequency in the 30 minute drug application period (see below). The 0.1 u/ml concentration was potent in its effect upon synaptic events and yet did not significantly change the RMP during the PLC application period. Therefore, this concentration was used in all of the experiments. It should be pointed out that after boiling the PLC for 10 minutes, the PLC was deactivated and its effect upon the RMP at concentrations of 25 u/ml, abolished.

#### Miniature Endplate Potential (mEPP)

Three sets of data were collected in these experiments: the mEPP frequency, the mEPP amplitude and the RMP. From the combined results, it appears that a change in the mEPP frequency and amplitude could occur without a significant shift in the RMP. The most pronounced effect was an increase in the mEPP frequency. Table #1 shows the

averaged mEPP frequency during the control period compared to the period of peak drug effect; the release of vesicles was potentiated by a statistically significant 60% increase in the frequency above the control level.

## TABLE 1

The table shows the results of the averaged mEPP frequency/5 secs.  $\pm$  SE and mEPP amplitude  $\pm$  SE, during the control and drug phases. The percentage of change from the control is also shown.  $p \leq 0.05$ , indicated by an asterisk.  $n = 9$ .

	CONTROL	PLC-TREATED	%
mEPP frequency/5sec	4.80 ± 0.3	8.10 ± 1.5 *	+64
mEPP amplitude (mV)	1.32 ± 0.11	1.45 ± 0.13 *	+12
	n=9		



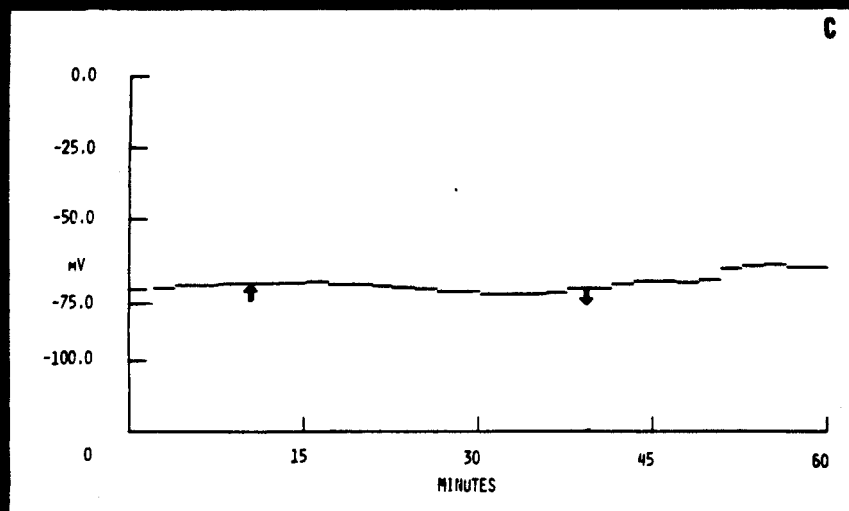
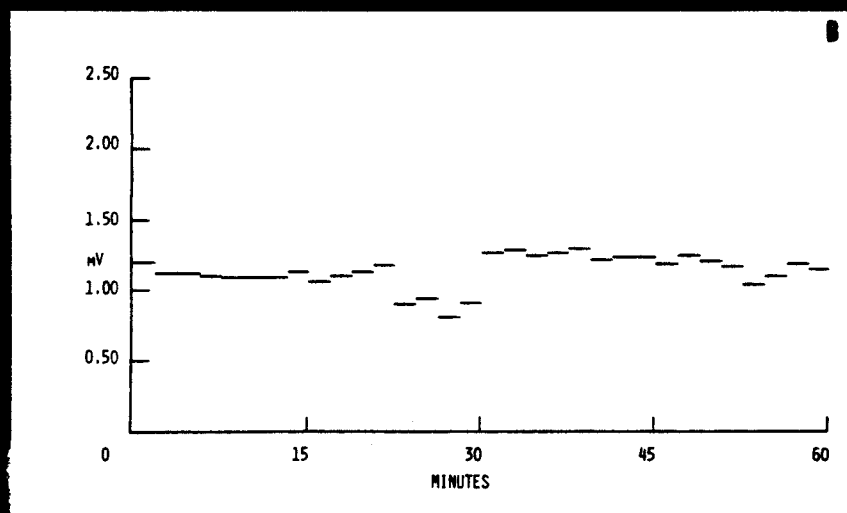
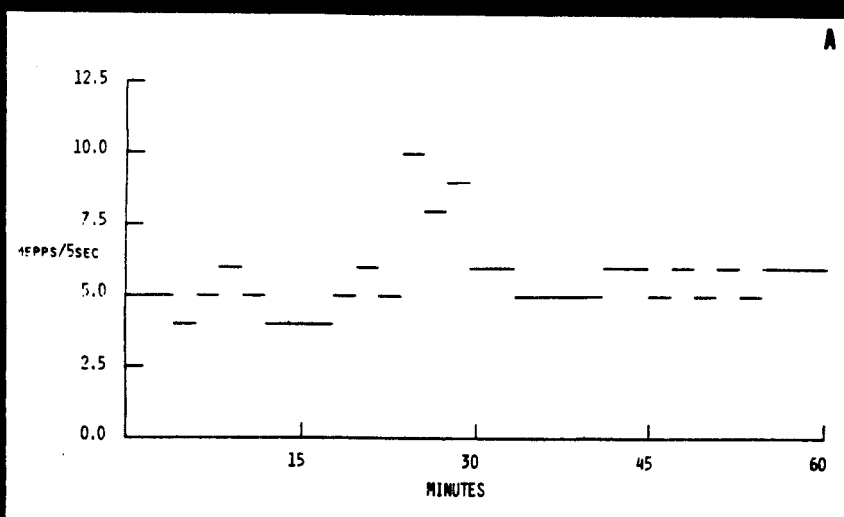
**FIGURE 6**

mEPP experiment.

A - Frequency graph of mEPPs/5 seconds.

B - Amplitude graph of mEPPs.

C - RMP graph; the arrows indicate the onset of PLC (.1 u/ml) perfusion and the beginning of washout. Note the inverse relationship between the frequency and the amplitude.



## FIGURE 7

mEPP experiment.

A - Frequency graph of mEPPs/5 seconds.

B - Amplitude graph.

C - RMP; the arrows indicate the onset of PLC (0.1 u/ml) application and the beginning of the washout. Note the potentiating effect of the washout.

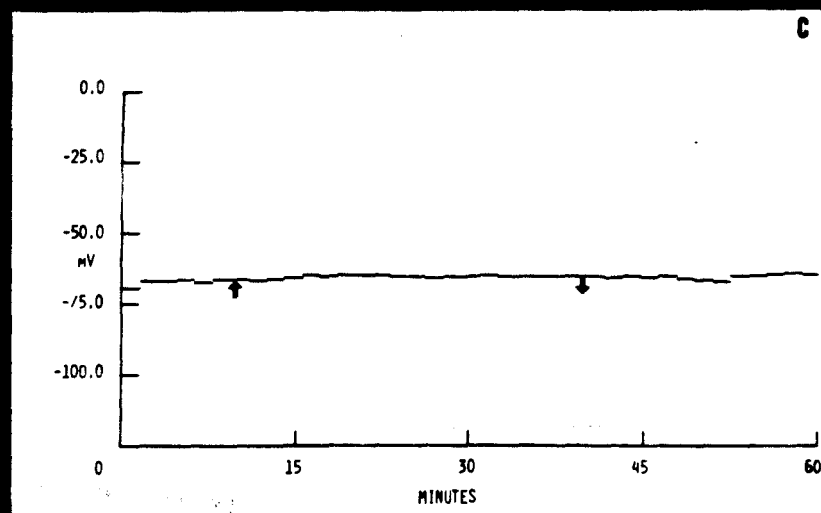
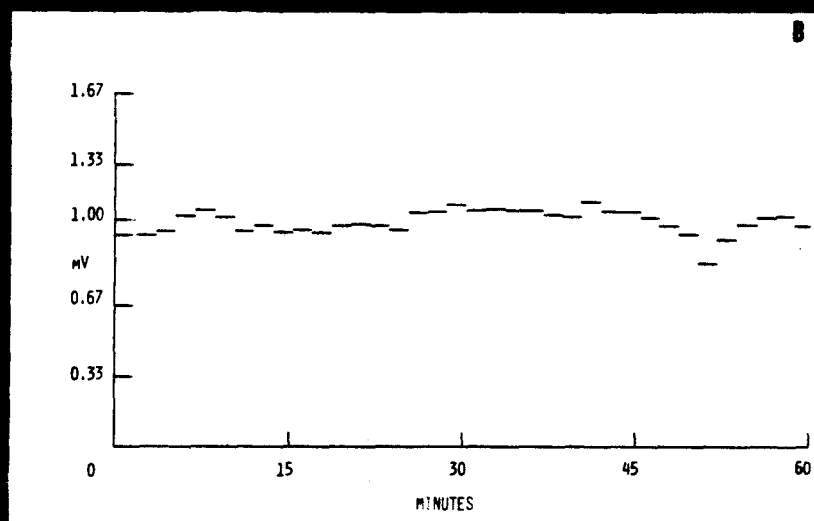
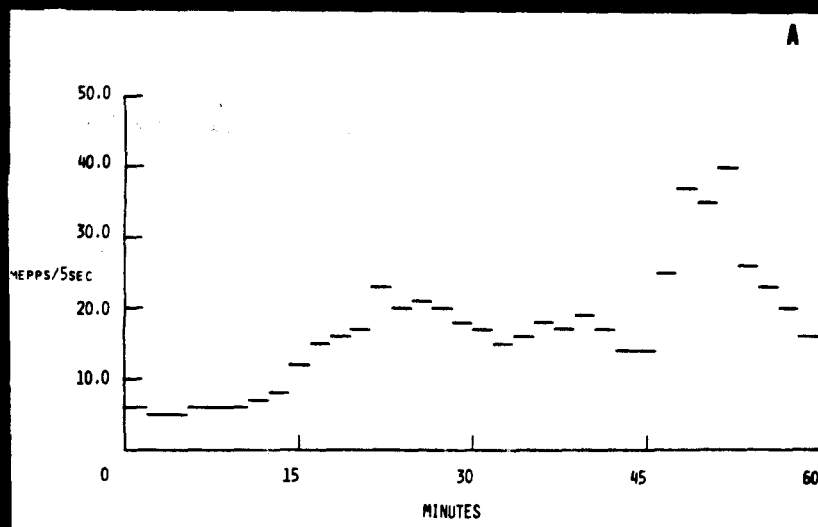


Figure 6 shows an example of a typical experiment. The top plate (A) is a graph of the mEPPs average frequency collected in five second intervals for the duration of the experiment. Each horizontal bar represents the average frequency of mEPPs per 108 seconds. The arrows indicate the onset of drug application and the onset of the washout phase. The effect of PLC upon the mEPP frequency was clear cut; though statistically significant, the effect of PLC upon the amplitude was less extensive amounting to 10% as shown in Table 1.

The second plate (B) represents a plot of amplitudes collected in five second intervals over time. The horizontal bars represent the average amplitude during 108 seconds. Finally, the third plate (C) represents the recording of the RMP over time. From these figures, it appears that PLC's most significant effect is upon the frequency of mEPPs. The amplitude appears to be less affected. Moreover, there appears to be an inverse relationship between the amplitude and the frequency of the mEPPs during the maximal PLC-induced increase in mEPP frequency.

TABLE 2

This table shows the pooled EPP amplitudes in (mV) during the phases of the control and peak drug effect, as well as, the percentage of change from the control, as calculated for each experiment. During the control and peak drug effect, the amplitude, the 50% rise-time in (ms) and the 50% and 75% decay-times were calculated for these experiments with the percentage of change calculated.  $p < 0.05$ . Statistically significant results are indicated by an asterisk.

n = 9.

	CONTROL	PLC-TREATED	%
EPP AMPLITUDE (mV)	1.6 ± 0.26	2.0 ± 0.34 *	+24
50% RISE-TIME (mS)	0.43 ± 0.08	0.49 ± 0.1	
50% DECAY-TIME (mS)	1.1 ± 0.06	1.3 ± 0.1 *	+21
75% DECAY-TIME (mS)	2.1 ± 0.1	2.6 ± 0.2 *	+24
	n=9		

## FIGURE 8

EPP experiment performed in half-block (1-3  $\mu\text{M}$ ) dTc.

A - Plot of the averaged amplitudes.

B - RMP during the experiment with the arrows indicating the onset of (0.1  $\mu\text{M}$ ) PLC application.

C - Actual averaged waveforms collected during the control period. The 50% and 75% decay-times and the 50% rise-times are also shown.

D - Actual averaged waveform collected at the end of the drug application period.



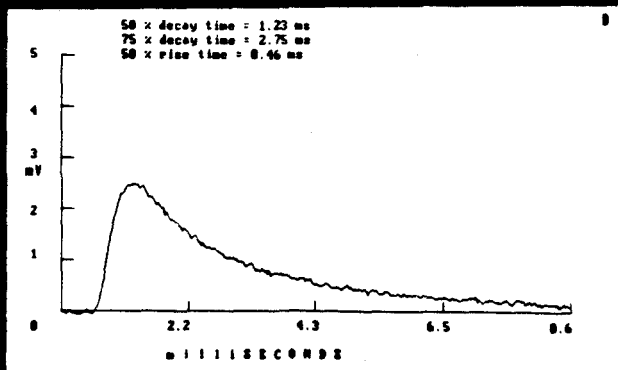
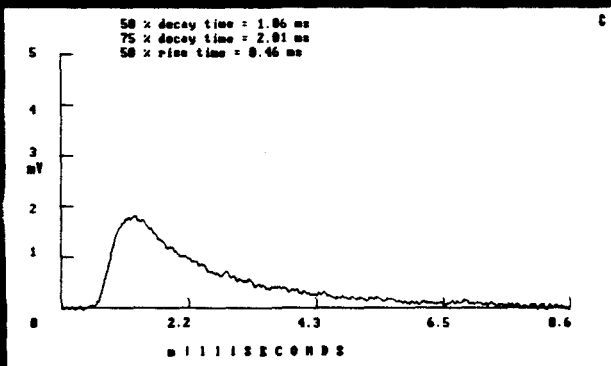
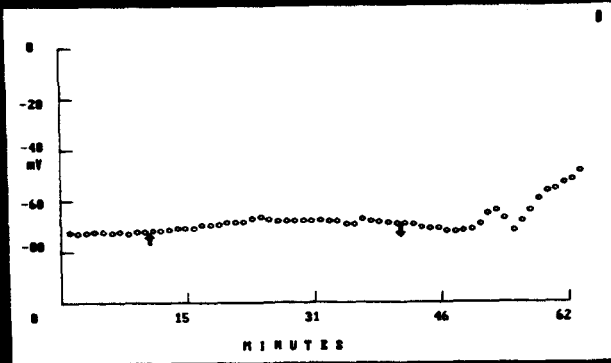
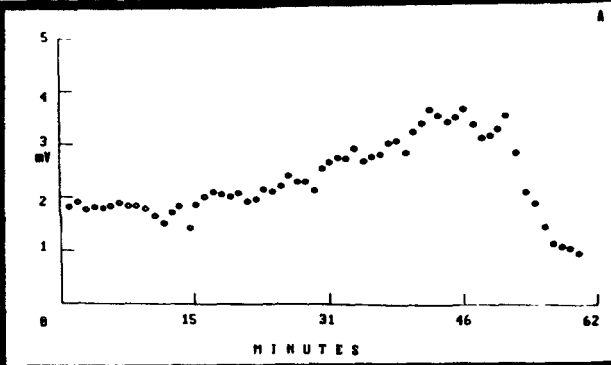


TABLE 3

This table shows the results of the EPP's amplitude (mV), rise-time and decay-time (ms) analysis in low Ca<sup>++</sup>/high Mg<sup>++</sup> Ringer. The averaged 50% and 75% decay-times  $\pm$  SE are shown during the control and drug periods, as is the percentage of change as compared to the control.  $p \leq 0.05$ , indicated by an asterisk.  $n = 9$ .

	CONTROL	PLC-TREATED	%
EPP AMPLITUDE (mV)	2.3 ± 0.4	3.0 ± 0.5 *	+41
50% RISE-TIME (mS)	0.43 ± 0.02	0.42 ± 0.01	
50% DECAY-TIME (mS)	0.88 ± 0.1	1.10 ± 0.1 *	+28
75% DECAY-TIME (mS)	1.60 ± 0.15	2.10 ± 0.27 *	+31
	n=9		

Figure 7 shows another experiment in which an interesting phenomenon was observed, i.e., a biphasic effect of PLC on the mEPP frequency. In plate (A) a primary potentiation of the mEPP frequency can be seen followed by an even greater enhancement during the washout phase. Observations of this type, led the investigator to extend the duration of PLC application. Plate (B) shows the correlation of the mEPP frequency and the amplitude during the frequency changes. As observed in the previous figure (Figure 6), there seems to be an inverse relationship between the frequency of mEPPs and the amplitude. Plate C shows that there was no change in the RMP.

#### Endplate Potential (EPP)

In Table 2, the pooled data concerns EPP amplitudes, recorded in a dTc Ringer. They indicate a statistically significant mean 24% increase in the amplitude due to the action of PLC (n = 9). As it may be seen in the Figure 8, there is a progressive increase in the EPP amplitude after initiation of PLC application (Plate A). There is also a statistically significant prolongation of the EPPs (see Table 2). The two measurements were carried out with respect to the decay-time, as visual inspection of the actual waveforms indicates the appearance of a "prolonged

tail". To test whether the later portion of the decay decreased at a slower rate, the 75% decay-time was also measured. It appeared that PLC caused a 21% increase in the mean 50% decay-time and 24% increase in the mean 75% decay-time. The rise-times showed no change.

## FIGURE 9

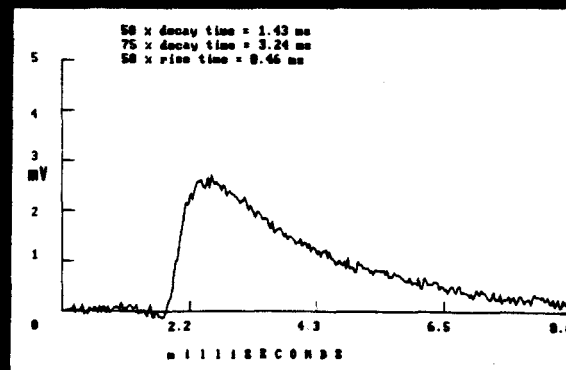
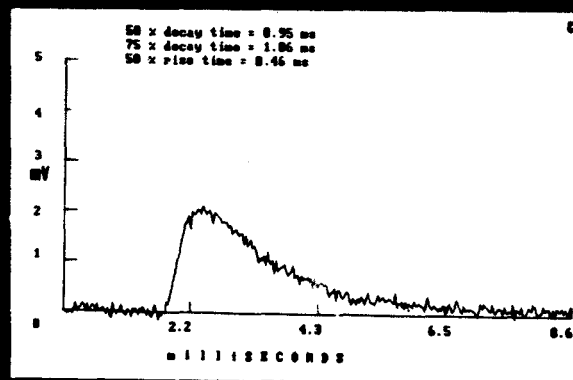
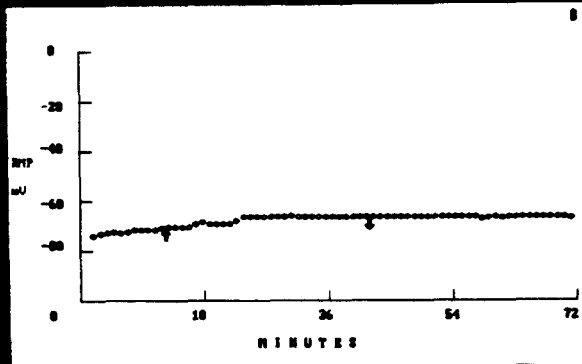
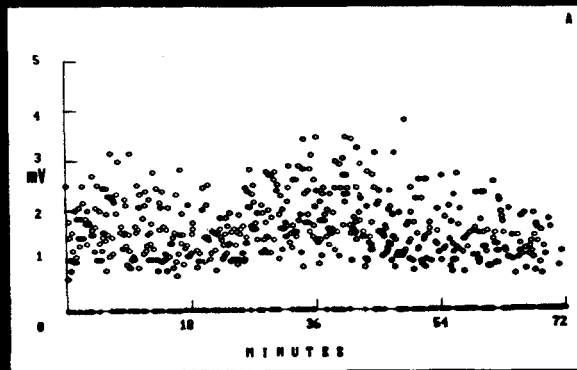
EPP amplitude experiment in the modified Ringer (low  $\text{Ca}^{++}$ /high  $\text{Mg}^{++}$ ) solution.

A - Amplitudes collected during the experiment; the failures are indicated as (0 mV).

B - Averaged RMP during the experiment with the arrows indicating the onset of (0.1  $\mu\text{g/ml}$ ) PLC perfusion and the onset of washout.

C - Amplitude histogram during the control period.

D - Amplitude histogram during drug application, indicating a shift in the EPP amplitude.



A typical example of PLC's action on the waveform is shown in Figure 8. Plate (C) shows an EPP waveform composed of individual EPPs during the control period, the drug period (D), the 50% rise-time, as well as, the 50% and 75% decay-times are indicated.

In high  $Mg^{++}$ /low  $Ca^{++}$  solution, the evaluation of the EPPs was performed (see Table 3); the averaged amplitude of the EPPs shows a significant increase, 41% above the control level. As compared to the control, the 50% and 75% decay-times were prolonged by 28% and 31%, respectively; there was no change in the rise-time. A typical experiment is shown in Figure 9. Plate (A) represents a plot of individual EPP amplitudes for the duration of the experiment. By visual inspection, with time, one observes a shift in the EPP amplitudes together with a reduction in the number of failures. The bottom plates show a histogram analysis of the amplitudes. The top histogram (C) shows the distribution of amplitudes in the control phase of the experiment; the bottom histogram (D) shows the amplitude distribution during PLC application. With the appearance of large EPPs in the 9 mV range, it is apparent that PLC induced a shift in amplitude.



TABLE 4

This table shows the results of two methods used in generating the ACh potential i.e., bath-applied and microejected. The averaged amplitudes (mV)  $\pm$  SE and the percentage of change from the mean are shown for both the control and drug phases.  $p \leq 0.05$ , indicated by an asterisk.  $n_1 = 6$ , the number of experiments in the bath applied ACh potential experiments.  $n_2 = 4$ , the number of experiments in the microejection ACh potential experiments.

	CONTROL	PLC-TREATED	%
BATH APPLIED ACh AMPLITUDE (mV)	3.6 ± 0.69  n=6	5.7 ± 0.60 *	+59
MICROEJECTION ACh AMPLITUDE (mV)	3.8 ± 1.8  n=4	6.7 ± 2.4 *	+82

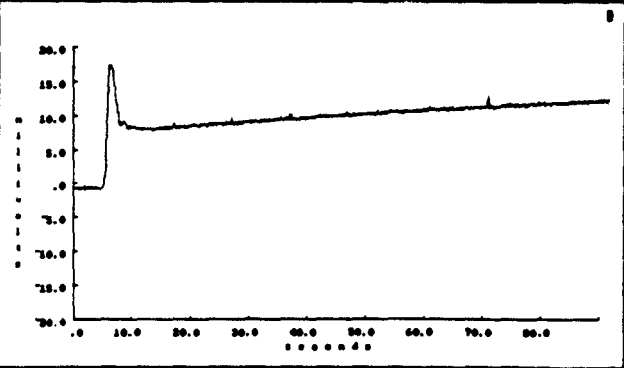
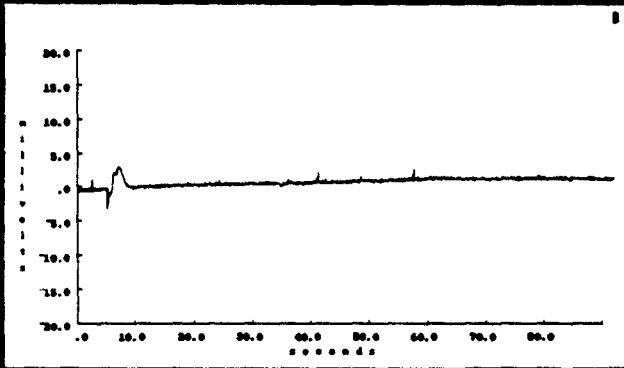
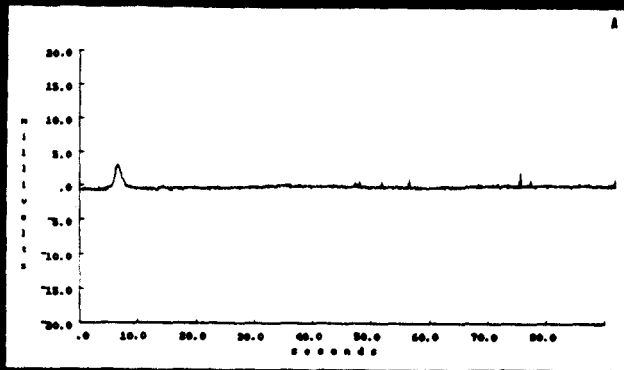
## ACh Potential

Both bath-applied and pressure-ejected ACh potential experiments show consistent results; they both indicate an increase in the ACh potential during PLC application. Table 4 shows the grouped data for both types of experiments; in bath-applied ACh experiments, the mean amplitude increased from 3.6 mV to 5.7 mV (approximately a 60% increase); this change was significant. In the case of the pressure-applied ACh experiments, the increase was from 3.8 mV to 6.7 mV, an 82% increase. This change was also significant. An example of each type of experiment is shown in Figures 10 and 11. Figure 10 shows two control recordings, plates (A) and (B), separated from each other by 10 minute washout periods. The second set of waveforms, shown in plates (C) and (D), were generated during PLC application; the first waveform (Plate C) was generated by applying ACh after 10 minutes of PLC application; approximately a threefold increase in size occurred. The last figure in the series, plate (D), shows the affect of ACh application after 20 minutes of exposure to PLC. Compared to the previous response, this response is potentiated still more; however, the depolarization did not return to the baseline. This particular phenomenon, where the RMP remained depolarized, was frequent in bath-applied ACh experiments, particularly during the second half (20 minutes) of PLC application.

## FIGURE 10

Bath-applied ACh experiment.

- A - ACh potential during the control phase.
- B - Control trace 10 minutes following A.
- C - ACh potential after 10 minutes of PLC application.
- D - ACh potential after 20 minutes of PLC application. This recording did not return to the control RMP.



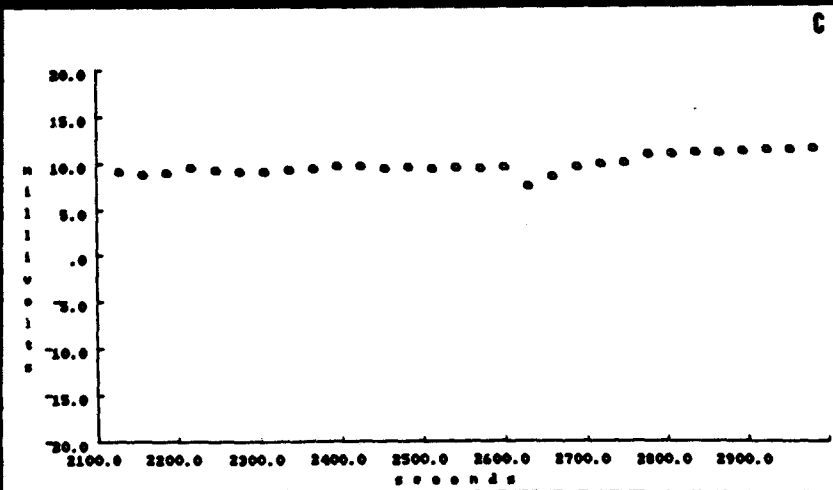
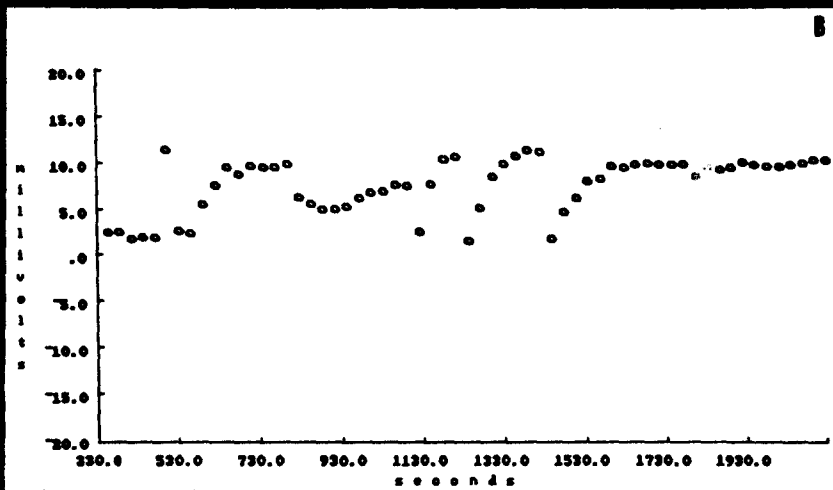
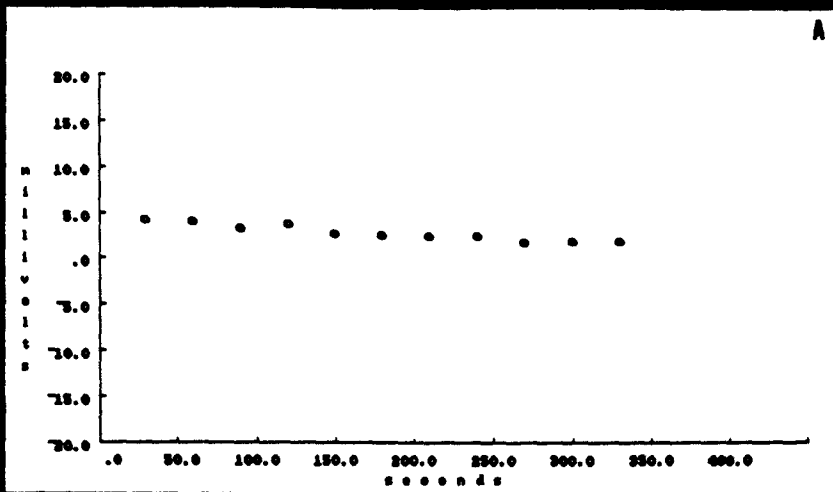
**FIGURE 11**

Pressure generated ACh potential. The circles indicate the individual amplitudes of ACh potentials.

A - Control period.

B - PLC (0.1  $\mu$ /ml) application period.

C - Washout period.

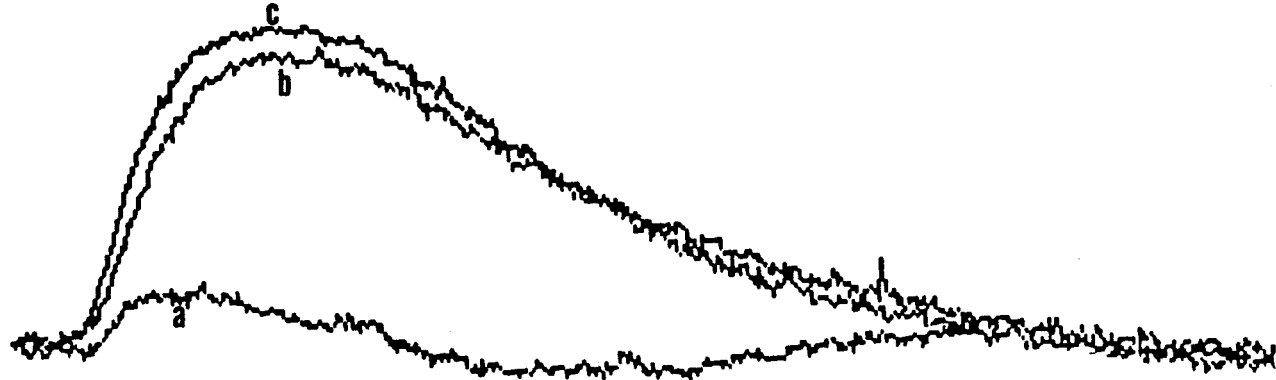


**FIGURE 12**

Averaged waveforms recorded during the individual experimental periods in Figure 11.

- a) Control period.
- b) PLC application period.
- c) Washout period.





5mV  
100msec

A typical experiment with pressure-applied ACh is shown in Figure 11. The first plate (A) shows the individual amplitudes of the ACh potential during the control phase. The second plate (B) shows the amplitudes of individual ACh potentials recorded during the PLC phase. During PLC application, the examination of individual waveforms revealed no change other than a change in amplitude. It is interesting to observe the early increase in amplitude variability following PLC application. It is also interesting to observe the stability of the response towards the end of PLC application and during washout.

The actual waveforms of the averaged responses obtained during the control period, the last phase of the drug period and the washout period, are represented in Figure 12. There was a marked potentiation of amplitude from the control level (2.8 mV), to the level recorded during drug treatment (9.2 mV), and to the level recorded during the washout (10.9 mV).

## Carbachol Potential

In view of the results observed with the ACh potential, to eliminate the possibility that PLC potentiated the ACh amplitude due to acetylcholinesterase (AChE) inhibition, the carbachol potential experiments were conducted, as carbachol is not hydrolyzed by AChE. Table 5 shows the data pooled from 5 experiments; the mean control amplitude was 2.9 mV and the amplitude recorded during peak drug effect was 4.9 mV, an increase of 69%. The mean 50% decay-time for the two phases is also indicated. The mean control decay-time was 0.14 seconds compared to the mean drug decay-time of 0.18 seconds. Figure 13 shows a typical experiment. There are three plates, showing individual amplitudes over the duration of each given experimental phase. The first plate (A) represents the control phase; the mean amplitude amounted to 1.76 mV. Plate (B) shows the drug application phase; at the end of the drug application period, the mean amplitude was 3.76 mV. Finally, plate (C) shows the washout phase with a mean amplitude of 4.5 mV.

The actual waveforms are shown in Figure 14. The three averaged waveforms are shown superimposed upon each other. A significant potentiation of amplitude can be observed between the control, drug and washout phases.

TABLE 5

This table shows the averaged amplitude of the carbachol potential in (mV) and the 50% decay-times generated by microejection, during the control and drug periods  $\pm$  SE. The percentage of change from the control is also indicated.  $p \leq 0.5$ .  $n = 5$ .

	CONTROL	PLC-TREATED	%
MICROEJECTION CARB. AMPLITUDE (mV)	2.9 ± 0.82	4.96 ± 1.4 *	+69
50% DECAY-TIME (S)	0.14 ± 0.01	0.18 ± 0.01 *	+33
	n=5		

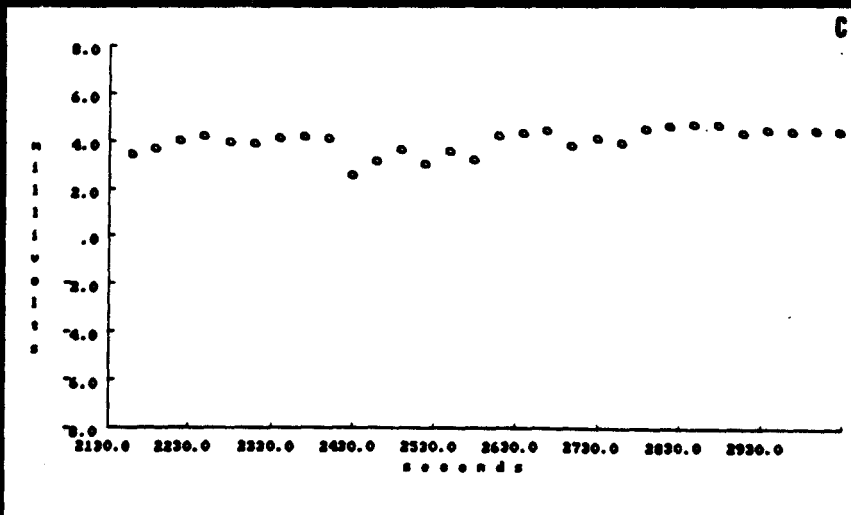
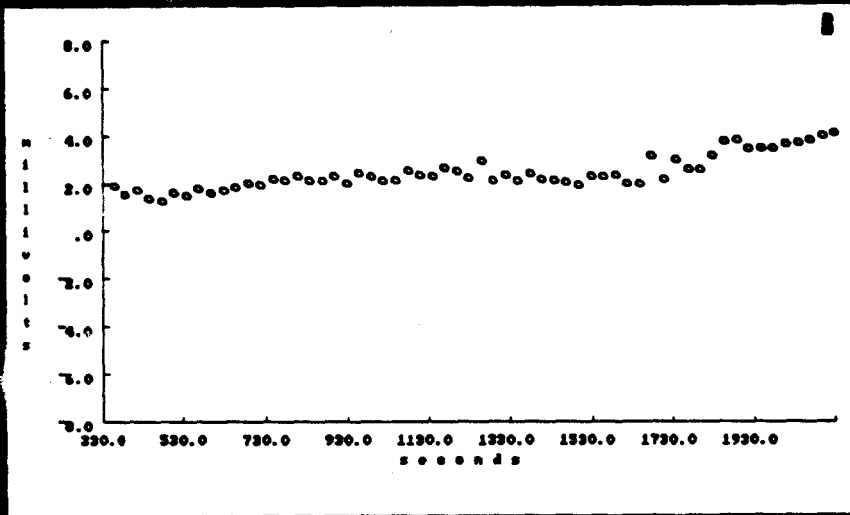
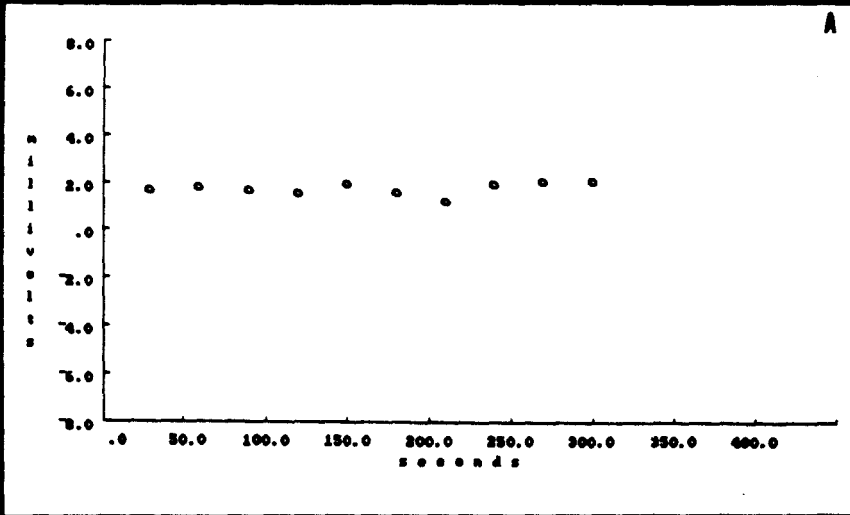
**FIGURE 13**

Pressure generated carbachol potential. Each circle represents an individual amplitude.

A - Control period.

B - (0.1 u/ml) PLC application period.

C - Washout period.

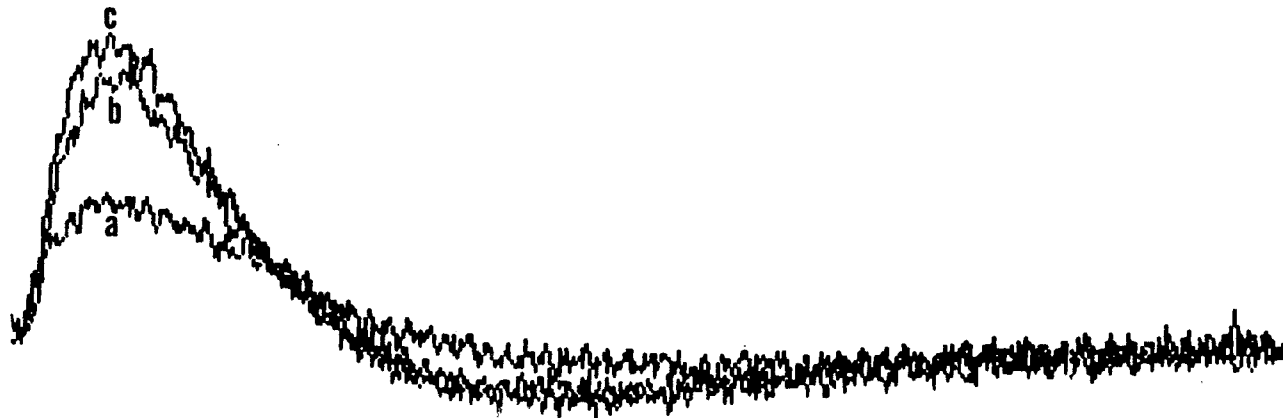


**FIGURE 14**

Averaged waveforms collected during the periods indicated in Figure 13.

- a) Control period.
- b) PLC application period.
- c) Washout period.





2 mV  
200 msec

## Quantal Content

Two methods for estimating the Quantal Content ( $m$ ) were used:

In the failure method, muscle contraction was prevented by using Ringer solution that contained 11 mM Mg<sup>++</sup> and .1 mM Ca<sup>++</sup>. This modified Ringer solution allowed a decreased release of ACh; occasionally, the endplate failed to respond to the axonal action potential. It was found that 0.1 u/ml PLC increased the ( $m$ ) value by 32% (see Table 6); this change was highly significant. The table shows the mean quantal content of nine experiments in both control and drug phases. The ( $m$ ) was calculated according to the formula:

$$m = \ln (N/No)$$

Where N is the total number of trials and No is the total number of failures.

An example of a typical experiment is shown in Figure 15. The top plate (A) shows a plot of EPP amplitudes recorded throughout the experiment. Each circle represents a specific EPP amplitude. The failures are represented by 0 mV amplitudes. The arrows indicate the time of PLC application and the washout period. Visual inspection indicates that there was a decreased number of failures during drug application and an increase in the amplitude of the EPPs (see the section on EPPs). The lower plate (B) represents the RMP values (mV) recorded for the duration of

the experiment; the arrows indicate the time of drug (PLC) perfusion and the time of washout initiation. It is apparent from the figure that during the experiment, there was very little change in the cell's stability, as indicated by the RMP (Plate B). Each circle, here, represents a mean RMP over a one minute interval.

TABLE 6

The quantal content was ( $m$ ) calculated by two methods: the normal Ringer/variance method and the low  $\text{Ca}^{++}$ /high  $\text{Mg}^{++}$ /failure method. The Quantal Content ( $m$ ) was calculated during the control and drug application periods; the percentage of change from the control is indicated. Each  $m \pm \text{SE}$  represents the averaged results of  $n = 9$  experiments for the normal Ringer;  $n = 8$  for low  $\text{Ca}^{++}$ /high  $\text{Mg}^{++}$ .  $p \leq 0.05$ , and is indicated by an asterisk.

	CONTROL QUANTAL CONTENT	PLC-TREATED QUANTAL CONTENT	%
NORMAL RINGER	m = 65 ± 11 n=9	m = 79 ± 12 * n=9	+23
LOW Ca <sup>++</sup> /HIGH Mg <sup>++</sup> RINGER	m = 1.8 ± 0.3 n=9	m = 2.3 ± 0.3 * n=9	+32

## FIGURE 15

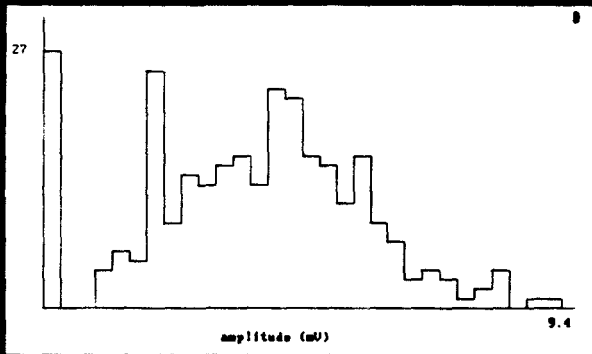
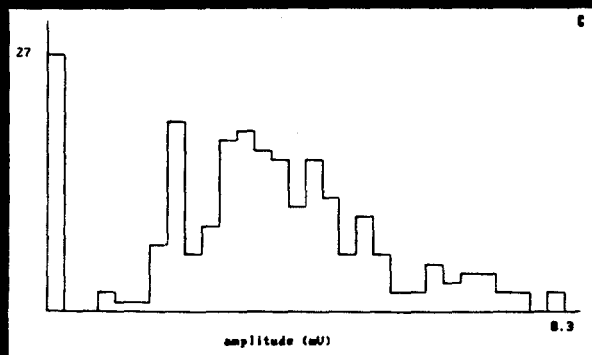
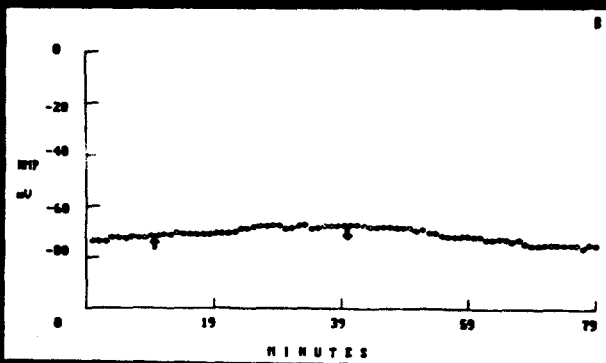
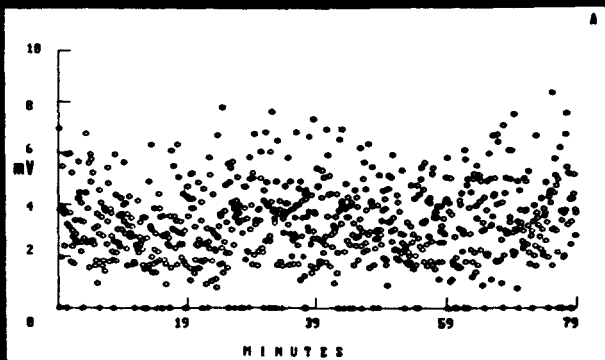
Quantal content experiment where the failure method was used.

A - Amplitudes with circles representing individual EPPs.

B - RMP during the experiment. Each circle represents the RMP during one minute. The arrows indicate the initiation of the (0.1 u/ml) PLC application and the washout period.

C - Averaged EPP waveform (without failures). The EPP rise-time and decay-times are indicated.

D - Averaged EPP waveform (without failures) collected during the end of the drug application period.



Examples of the actual EPP waveforms are represented in Figure 15. Plate (C) shows a typical waveform collected at the end of the control period. Plate (D) shows a typical waveform recorded at the end of PLC application. An increase in the amplitude and an increase in the duration of the decay-phase was observed.

The other method employed to evaluate the quantal content ( $m$ ) was that of del Castillo and Katz (1954) as modified by Warnick et al. (1978). The formula used for the estimation of ( $m$ ) was:

$$m = 1/CV^2$$

where CV is the coefficient of variation.

As with the results obtained in the failure method (see Table 6), from the control period to the drug period, there was an 23% increase in the quantal content ( $m$ ). This increase was significant. Here again, data are pooled from nine independent experiments. (For a typical experiment see Figure 8.)



## TABLE 7

This table shows the results of the electrotonic potential experiments, the mean amplitude (mV)  $\pm$  SE and the mean membrane resistance (Kohms)  $\pm$  SE, during the control and drug phases. The control and drug phases do not differ from each other.  $p \leq 0.05$ .  $n = 6$ .

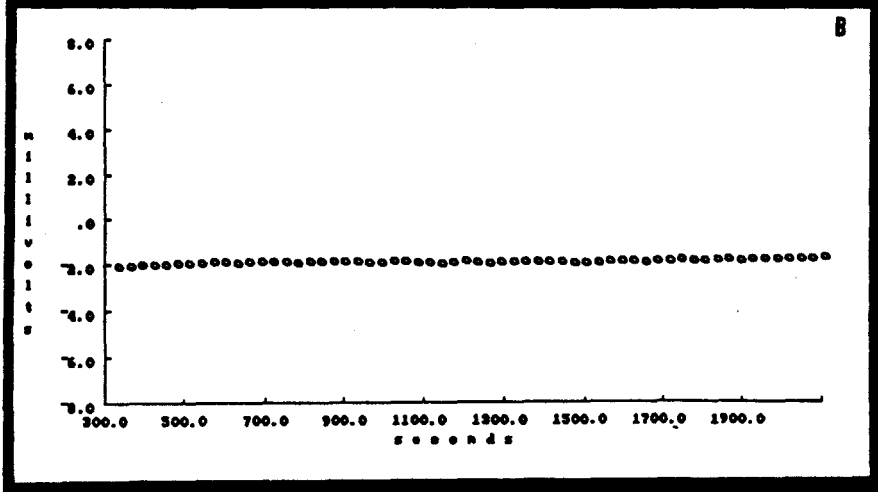
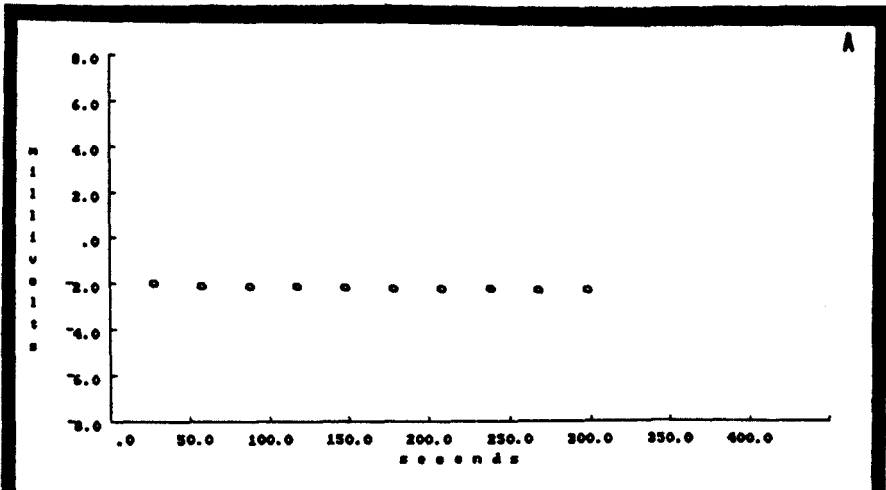
	CONTROL	PLC-TREATED
AMPLITUDE (mV)	4.9 ± 0.58	4.8 ± 0.54
MEMBRANE RESISTANCE (kOHM)	3.7 ± 0.41	3.6 ± 0.50
	n=6	

## FIGURE 16

Electrotonic potential with circles representing individual waveform amplitudes.

A - Control period.

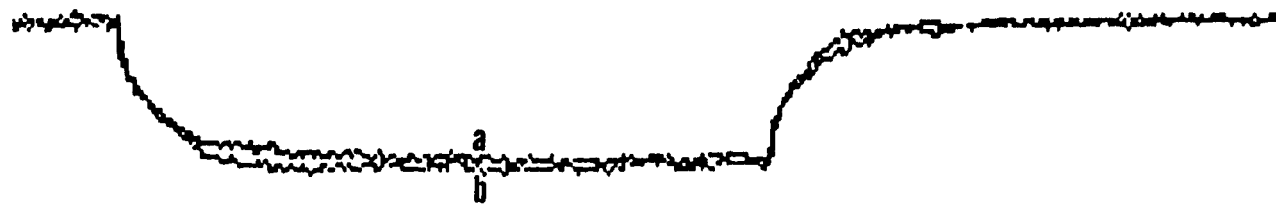
B - PLC application period (0.1 u/ml).



**FIGURE 17**

Averaged electrotonic waveform from the control and the end of the drug period.

- a) Control period.
- b) Washout period.



2mV  
10msec

## Electrotonic Potential

The study of the electrotonic potential was employed to eliminate the possibility that PLC's action upon post-synaptic membranes resulting from a change in the membrane resistance. The recording of the electrotonic potential, during PLC perfusion, showed no significant change in either the electrotonic potential or the membrane time constant.

Table 7 shows the pooled data for the electrotonic potential, the peak-negative amplitude during the control and drug phases, as well as, the calculated input resistance. During drug application, the peak amplitude of the potential and the input resistance were unchanged.

Figure 16 is an example of a typical experiment where the individual amplitudes of electrotonic potentials are shown plotted over the duration of the experiment. The top plate (A) shows the control portion of the experiment followed by (B) PLC application.

The actual waveforms recorded are shown in Figure 17, where the averaged waveforms of the control period and drug period are superimposed upon each other. There was no significant change in the appearance of the waveforms.

## Voltage Clamp

In the voltage clamp studies, the amplitude and the evoked waveform decay were analyzed via computer programs similar to those utilized in the evaluation of the EPPs.

However, in the voltage clamp studies, the voltage clamp circuit was used to maintain a very stable RMP and to record the current responsible for the EPPs (see Methods). In Table 8, the pooled current amplitudes, during the control and the peak drug periods, are shown to have a net increase of 12%. The other information in the table includes a 28% increase in the averaged 50% decay-time of the EPCs.

A typical experiment is shown in Figure 18, where the amplitudes of individual EPCs are plotted against time. The top plate (A) is the control period. This is followed by the PLC application period (B). The last two plates illustrate the events of the washout periods. It can be seen that there is a strong trend towards an increase in the current amplitude, especially in the washout period (Plate C). Plate (D) shows further increase in the amplitude followed by a loss of the clamp.

The actual averaged waveforms can be seen in Figure 19; the waveforms illustrate superimposed averaged EPCs. It can be seen that there is a gradual increase in the amplitude of the EPCs during the various experimental phases. The first amplitude representing a marked increase over the control period, is seen at the end of drug application; the next marked increase is seen at the end of the washout phase; the largest being seen during the late washout phase just prior to the loss of clamp integrity.



TABLE 8

This table shows the results of the voltage clamp experiments. The averaged amplitudes are shown in (nA)  $\pm$  SE during the control and drug phases. Also, the 50% decay-times were calculated during the two phases. The percentage of change from the control is shown.  $p < 0.05$ , indicated by an asterisk.  $n = 5$ .

	CONTROL	PLC-TREATED	%
AMPLITUDE (nA)	8.7 ± 1.5	9.9 ± 1.9 *	+12
50% DECAY (mS)	7.8 ± 1.7	9.6 ± 1.6 *	+28
	n=5		

## FIGURE 18

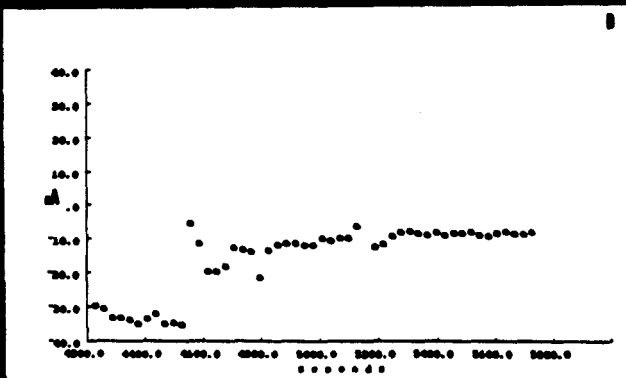
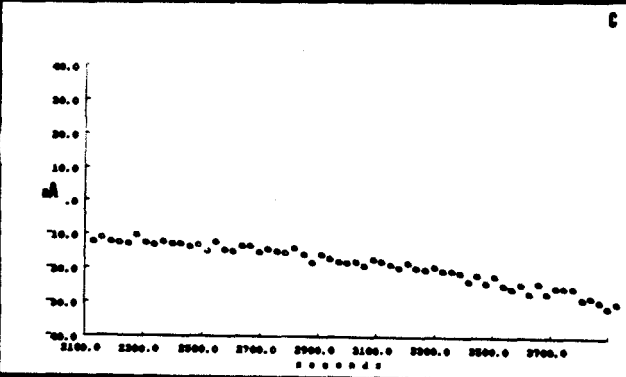
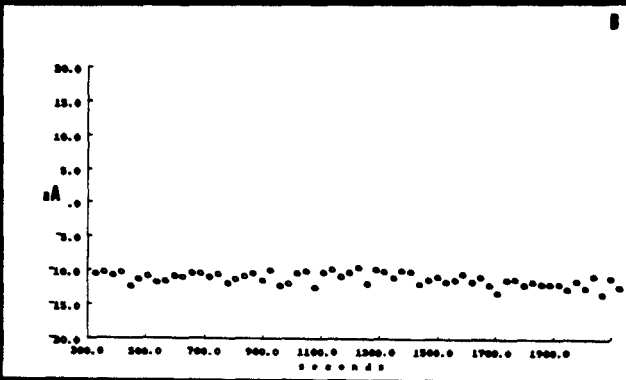
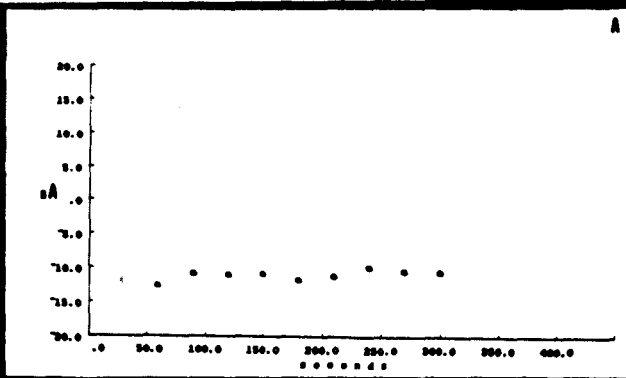
Voltage clamp experiment. The circles represent individual current amplitudes.

A - Control period.

B - PLC (0.1  $\mu$ /ml) application period.

C - Washout period.

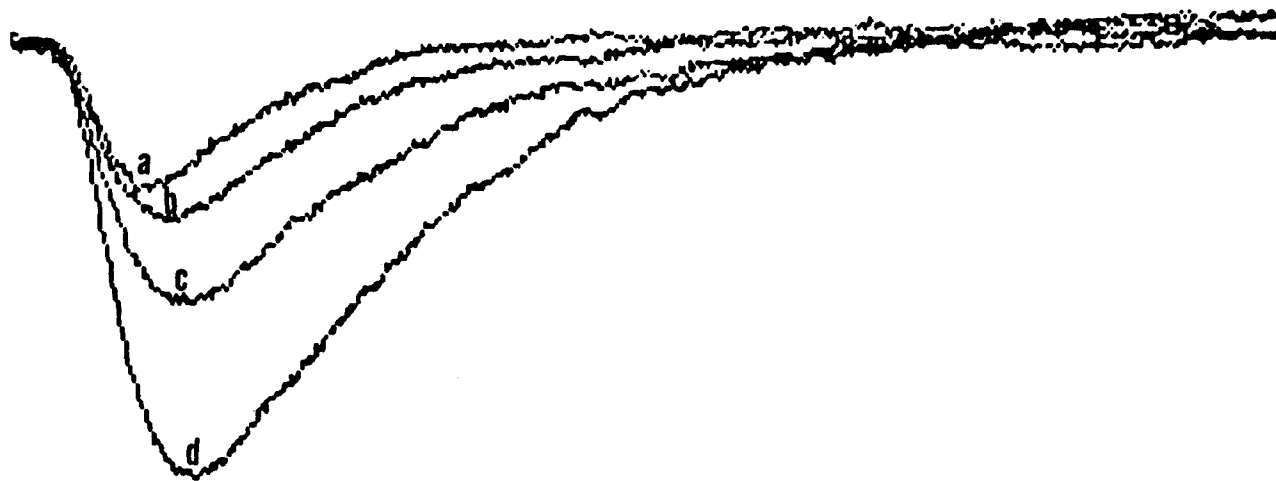
D - Continued washout, ending with a loss of the clamp.



## FIGURE 19

Averaged waveforms from the experiment in Figure 18.

- a) Control period.
- b) PLC application period.
- c) Washout period.
- d) Continued washout period.



10 nA  
2.5 msec

Since potentiation during washout was a recurring phenomenon (see the results concerning mEPP frequency and amplitude), it was interesting to see if a long PLC application period, would result in similar potentiation. Figure 20 shows a typical experiment in which the washout phase was substituted for prolonged PLC application.

The top plate (A) shows a control period followed by two plates representing PLC application periods, (B) and (C). As we can see, there was the typical increase in the EPC amplitude during the early PLC application period (B). Plate (C) shows the continuation of PLC application, ending with a loss of the cell's membrane integrity. The average waveforms obtained in this experiment, are shown in Figure-21. These waveforms are averaged during the control period, at the end of first drug application and during the prolonged PLC application, just prior to the loss of the cell's membrane integrity. It is apparent that there is a potentiating effect in the presence of PLC; however, it does not appear to be as great as during the washout potentiation period. The statistical significance of this difference was not established, for the primary objective of this study was not a comparison between the washout-induced potentiation of PLC application and the prolonged PLC application. However, in the future, it would be interesting to analyze the difference between the potentiation due to washout and the potentiation due to prolonged PLC application.

## FIGURE 20

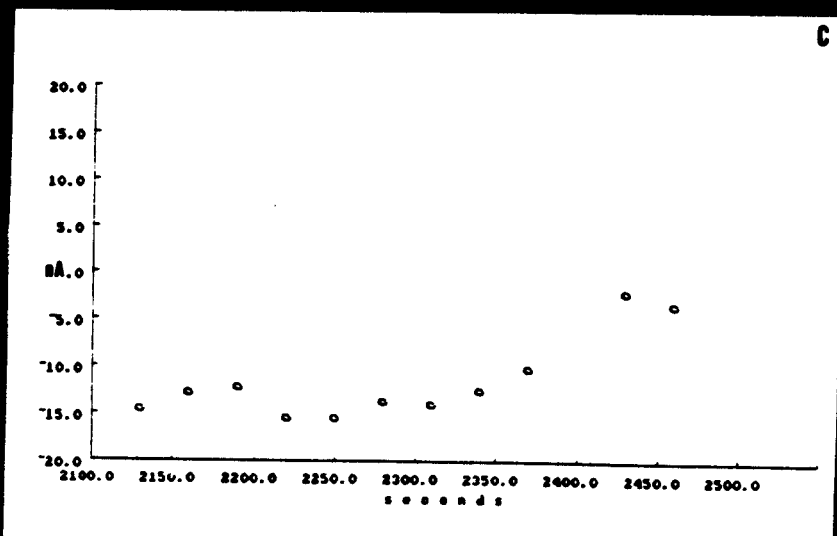
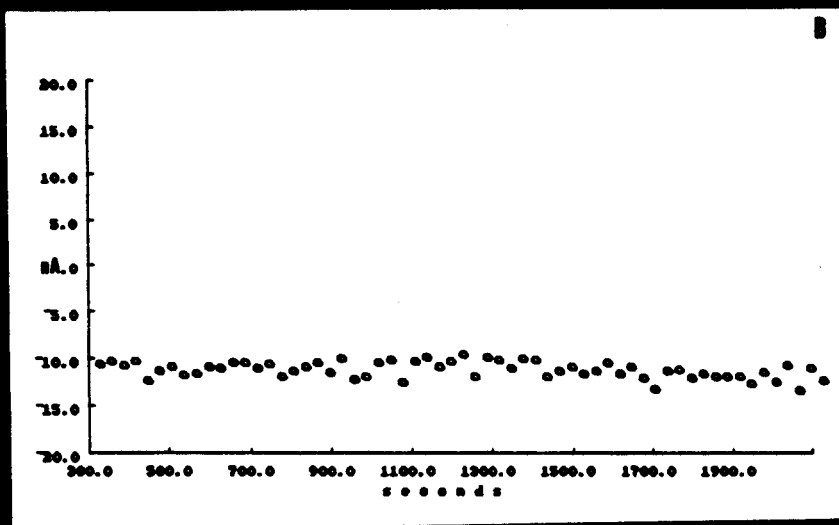
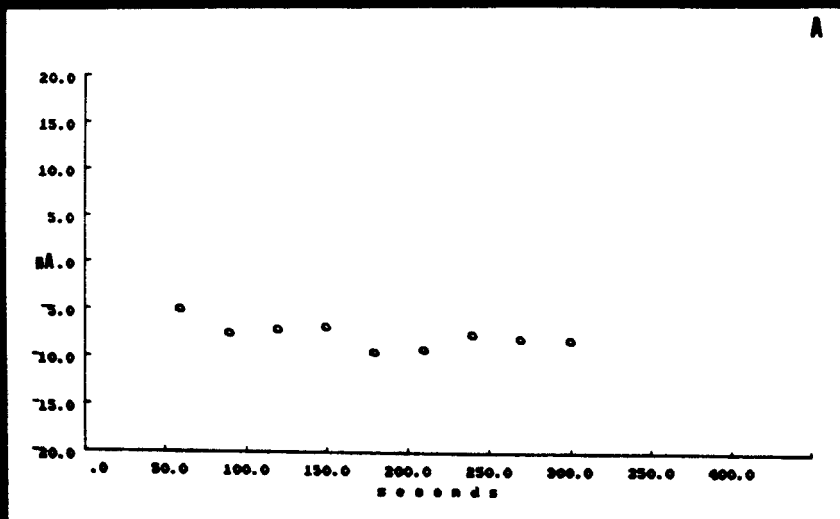
Voltage clamp experiment. The circles represent individual current amplitudes.

A - Control period.

B - PLC (0.1  $\mu$ /ml) application period.

C - Prolonged PLC application, ending with the loss of the cell.

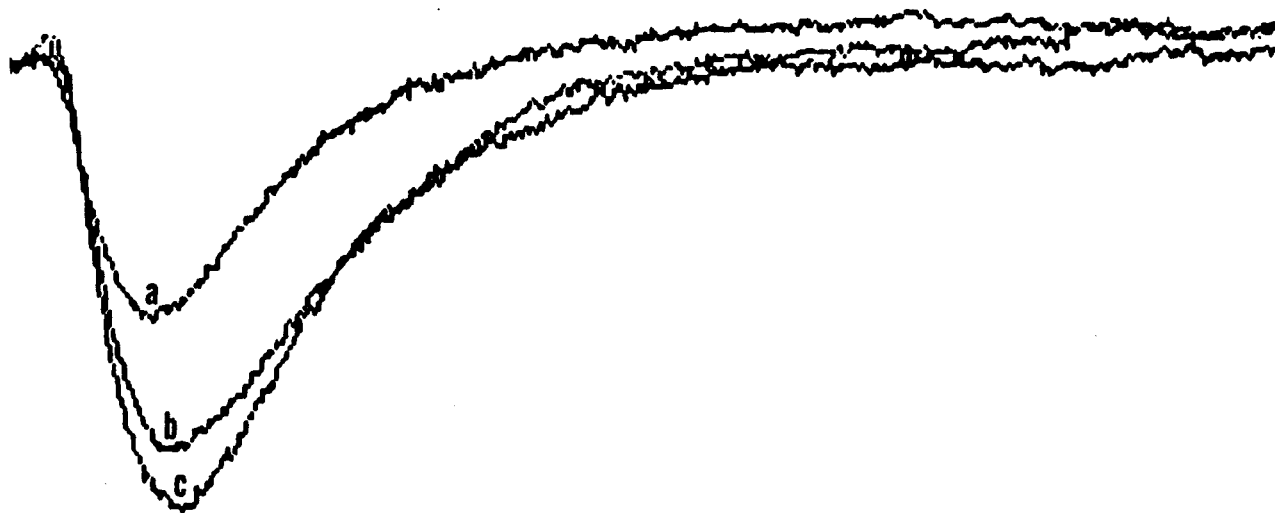




**FIGURE 21**

Averaged waveforms from the periods in Figure 20.

- a) Control period.
- b) PLC application period.
- c) Continued PLC application period.



5nA  
2.5 msec

## Summary of Results

- 1 The resting membrane potential was depolarized by applying 50-1 u/ml PLC. This effect was time dependent with higher concentrations depolarizing the membrane sooner. A concentration of 0.1 u/ml was found to be the most effective in generating a synaptic response without a depolarizing effect. The rest of the experiments were performed with 0.1 u/ml PLC.
- 2 In the cut-muscle preparation, the dTc-blocked preparation and the low  $\text{Ca}^{++}$ /high  $\text{Mg}^{++}$  solution, the recorded compound action potential was not affected by PLC.
- 3 The miniature endplate potentials were enhanced by PLC. Their amplitude increased significantly, by 12%; the frequency was increased significantly, by 64%.
- 4 The quantal content by the failure and variance methods showed a significant increase in the presence of PLC. A 23% increase was seen in the normal Ringer solution and 32% in the low  $\text{Ca}^{++}$ /high  $\text{Mg}^{++}$  solution.
- 5 Acetylcholine depolarization by bath-application was enhanced significantly, 59%, in the presence of PLC. The pressure ejected ACh potential was also increased significantly, by 82%.
- 6 The carbachol potential generated by microejection was significantly increased above the control, 69%, by the

- action of PLC. The wave analysis of this waveform showed a significant 33% increase in the 50% decay-time.
- 7 In the electrotonic analysis studies, neither the potential amplitude, nor the membrane input resistance showed any significant change in the presence of PLC.
- 8 The endplate current analysis showed a significant 12% increase in the amplitude and a 28% increase in the 50% decay-time due to the action of PLC.
- 9 The endplate potentials analyzed in PLC and normal Ringer, and in PLC and low  $\text{Ca}^{++}$ /high  $\text{Mg}^{++}$  Ringer, showed a significant increase in the amplitude, 24% and 41% respectively. The waveform analysis, under the above circumstances, showed a significant increase in the 50% decay-time, 21% and 28% respectively, and 75% decay-time, 24% and 31% respectively.

## DISCUSSION

The discussion is organized chronologically to follow the physiologic events at the neuromyal junction, i.e., the pre-synaptic effects of PLC will be discussed first, followed by the postsynaptic effects.

### Compound Axonal Action Potential

As was discussed in the introduction, axons are apparently very resistant systems. They are able to maintain conduction during insults, such as Diphtheria toxin demyelination or extensive dephospholipidation by phospholipases. The mechanisms involved are not well understood; yet, they may be related to the insult-induced fluidity change of the axonal membrane that allows for the reorganization of the Na<sup>+</sup> and K<sup>+</sup> channels. This reorganization shows significant adaptability as it allows for a shift from the saltatory to non-saltatory conduction.

In phospholipase studies using PLC from Clostridium welchii, PLD from cabbage and PLA from Ringhals venom, Rosenberg et al., (1968), found that axons exposed to concentrations of PLC as high as 90 u/ml for 30 minutes, showed no effect upon the axonal action potential. PLD was also ineffective in interfering with axonal conduction. The PLA effect, resulting in an irreversible conduction block, was attributed to the toxic action of the lysophosphatides and free fatty acids.

The above results appear to be consistent with the observations of the present work. It was shown that exposing the phrenic nerve to PLC, from Clostridium welchii at concentrations of 0.1 u/ml for 30 minutes, did not produce any significant change in the amplitude or waveform characteristics of the compound action potential. It is possible that the treatment used in this work was not severe enough to generate electrophysiologically observable changes; it appears that there is a relatively high threshold of resistance to change.

Considering the focus of this study, synaptic transmission, it might have been more useful to investigate pre-junctional currents, resulting from the action potential's invasion of the axon terminal. Brigant and Mallart (1982) have shown that there are three distinct types of currents present in the region of the axon terminal. These three currents were identified by their location and pharmacology. Na<sup>+</sup> currents were found to be localized specifically in the pre-terminal region, implying that Na<sup>+</sup> channels involved in action potential generation are localized there; the current was blocked by TTX. K<sup>+</sup> channels were located at the terminal parts of the axonal ending. This particular K<sup>+</sup> current was blocked by TEA and aminopyridines. Ca<sup>++</sup> currents were unmasked by K<sup>+</sup> channel blockers; they were located in close proximity to K<sup>+</sup> channels. It would be of great interest to analyze the

effects of PLC action upon these individual currents, especially in light of studies by Ohta and Karczmar (1981) that suggest a pre-synaptic increase in  $Ca^{++}$  influx. Unfortunately, because of the anatomy of the preparation, this dissertation work did not lend itself to this type of analysis. The phrenic nerve-diaphragm preparation of the mouse is composed of very tightly organized muscle with axonal terminals visually impossible to identify. Furthermore, with an extracellular electrode, access to these terminals is practically impossible because of the tough, connective tissue barrier. A much better preparation for this type of investigation would be the intrathoracic muscle, the triangularis sterni, used by Brigant et al., (1982). This muscle is ideal for electrophysiologic work on the nerve terminal; however, its dissection tends to be rather difficult (McArdle et al., 1981).

#### Miniature Endplate Potential (mEPP)

The increase in the mEPP amplitude, observed in this study, may have two components: a pre-synaptic, PLC-induced facilitatory effect and a post-synaptic effect.

The amplitude of mEPPs may be increased by several processes. As mentioned earlier, the increase in frequency may lead to an increased probability that several quanta will be simultaneously released, leading to summation. Also, there is a possibility that the content of individual



vesicles was altered by either a direct or indirect effect. PLC, by altering the synaptic membrane permeability, conceivably altered the packaging mechanisms. Also, PLC, by directly entering into the cytosol, may have had an effect upon the vesicles. Rosenberg et al. (1968) showed that PLC was capable of entering into the cytosol of the giant squid axon.

The increase in mEPP amplitude may also be related to a possible inhibition of AChE. However, the carbachol potential studies indicate that this mechanism cannot be a major factor. Another possibility leading to an increase in the amplitude of mEPPs lies in the unmasking of extra receptors in the junctional area, a hypothesis proposed by Harborne et al. (1978) in their studies on the action of PLC.

The increase in mEPP frequency is a  $Ca^{++}$  dependent pre-synaptic phenomenon. Thus, alteration of the micro-environment, in the area of the pre-synaptic terminal, will influence the spontaneous release of ACh. It has been shown by Hubbard et al. (1962) that hyperpolarization of the axon terminal has no effect upon the mEPP frequency; however, depolarization results in an initial increase in mEPP frequency (Bowman, 1980). The depolarization of the axon terminal could be caused by PLC in several ways: PLC might have a direct effect upon pre-synaptic terminals, resulting in an alteration in membrane properties that lead to

depolarization. There may be a structural difference in the membrane of pre- and post-synaptic structures with the former being more sensitive to PLC than the latter. This depolarization may be directly related to the quantal content increase.

Furthermore, the augmentation in the number of vesicles released per given time (mEPP frequency) may result in an increase in the ACh concentration within the synaptic region which, in turn, may lead to pre-synaptic, ACh receptor stimulation. This hypothesis depends upon the pre-synaptic presence of ACh receptors, and of course, on whether these are facilitatory or inhibitory. There are confusing reports on the facilitatory and inhibitory properties of pre-synaptic receptors in the NMJ preparation; for example, the data of Ganguly et al. (1979) suggest that there are excitatory pre-synaptic receptors that facilitate the release of ACh. On the other hand, Abbs et al. (1981) showed the presence of muscarinic inhibitory receptors. These conflicting results were explained by questioning the sensitivity of the methods used for measuring the amount of ACh released. Others have suggested a total absence of pre-synaptic receptors in the phrenic nerve-diaphragm preparation (Gundersen et al., 1980).

The third possibility is related to the author's unpublished observations. It was observed that not only was there an increased amplitude in individual mEPPs, but also,

augmented duration (half decay-time) of the mEPPs. This may lead to a transient increase in the extracellular  $K^+$  concentration, resulting in pre-synaptic  $K^+$  depolarization.

The hypothetical depolarization mechanisms suggested to be involved in the PLC effect on the nerve terminal are directly related to the  $Ca^{++}$  currents, as was shown by Brigant and Mallart (1982).  $Ca^{++}$  currents ultimately are responsible for the increase in mEPP frequency observed as a results of PLC activity. Ohta and Karczmar (1981) showed that the pre-synaptic effects of PLC, i.e., mEPP frequency augmentation, is blocked by  $Ca^{++}$  channel blockers. It is possible that PLC's pre-synaptic activity may involve the generation of endogenous  $Ca^{++}$  ionophores, such as phosphatidic acid, which in turn may lead to an increase in the intracellular  $Ca^{++}$ , resulting in the augmentation of the mEPP frequency (Ohta et al., 1981).

#### Quantal Content

Quantal content measurements, based upon del Castillo's and Katz' (1954) quantal hypothesis, have been challenged by studies done by Kriebel et al. (1974), Werning (1975) and others. They suggest that the classic mEPP is not the smallest unit of quanta released; rather the mEPP is composed of even smaller units which are called subunits. The evidence supporting the subunit hypothesis consists of populations of small mEPPs and the presence of multiple

peaks in the plots of mEPP amplitude histograms. The studies of Kriebel et al. (1974), Kriebel et al. (1976) and Kriebel (1978), in which subunit amplitudes did not change, have not accounted for the post-synaptic effect. They have shown that colchicine, increased  $Ca^{++}$  or  $Mg^{++}$  and increased temperature produce a reduction in the mEPP mode amplitude without changing the subunit amplitude. They interpreted these results as suggesting that the smallest unit is not the mEPP but rather the smEPP. However, studies of Mambrini et al. (1964) showed that increased  $Ca^{++}$ , applied iontophoretically, results in a decreased ACh potential. It is possible that this effect was mediated by the activation of AChE (Hofer et al., 1984).

Magleby et al. (1980), demonstrated that  $Ca^{++}$ , in concentrations of 2-10 mM, can decrease a single channel current by about 30%. A similar argument can be made for the effect of colchicine. Anwyl et al. (1977) showed a decrease in post-synaptic sensitivity as a result of colchicine treatment. Temperature would also be expected to have a post-synaptic effect (Dreyer et al., 1976). Furthermore, Magelby et al. (1981), while investigating the subunit hypothesis in the frog and mouse-hemidiaphragm, found that they were able to record, occasionally, what appeared to be subunit populations. However, by using the statistical method for evaluating data regularity, i.e., autocorrelation, they found that the peaks were not

regularly spaced as required by the subunit hypothesis. They concluded that, "It thus appears to us that there is little, if any, electrophysiological evidence that the mEPP is composed of subunits." They acknowledged, however, that there are anomalous mEPPs which could be perceived as subunits of mEPPs.

There is a body of biochemical experiments suggesting that the vesicular hypothesis may be false, i.e., that the unloading of vesicular contents results in and is the only source of mEPPs. By studying the vesicular and extravesicular ACh concentrations in the electric organ of the Torpedo, Israel and his collaborators (1972) found that due to K<sup>+</sup> stimulation, extravesicular ACh was depleted, followed by the vesicular ACh. They also observed that vesicular fusion with the pre-synaptic terminal membrane is not always associated with ACh release. Thus, they focused on a different phenomenon which appeared to be consistent in all experiments--an increased pre-synaptic membrane particle density as a result of pre-synaptic electrical stimulation, resulting in ACh release. After isolation, they were able to incorporate these particles into artificial membrane systems. When filled with ACh and treated with Ca<sup>++</sup>, these membrane systems released the ACh from within (Dunant and Israel, 1985). These studies may not undermine the quantal hypothesis, as one can easily envision a quantal-type release generated by individual or synchronous release of

ACh through the action of presynaptically embedded proteins, especially if their structures are comparable to ionic channels.

The present work has shown an increased quantal content as a result of PLC application in two different environments: the low  $\text{Ca}^{++}$ /high  $\text{Mg}^{++}$  solution used in the failure method; and in a normal Ringer solution, where dTc half-block was used to prevent muscle contraction and the variance method was employed for quantal content calculation. It is apparent that PLC caused a greater increase in quantal content--9%--in the low  $\text{Ca}^{++}$ /high  $\text{Mg}^{++}$  solution than in the normal Ringer. These results may not be significant when interpreted in isolation (see the results for a discussion); however, they are supported by the EPP amplitude and waveform analysis data collected in the two different solutions (low  $\text{Ca}^{++}$  /high  $\text{Mg}^{++}$  and Ringer). This discrepancy may be due to PLC's sensitivity to  $\text{Ca}^{++}$ .

It has been shown that Clostridium welchii secretes two types of lipases (VandenBosch, 1978). One is specific for sphingomyelin and the other for PLC, which hydrolyzes phosphatidylcholine, as well as, sphingomyelin (Paston et al., 1968). The former enzyme was shown to be independent of  $\text{Ca}^{++}$  for activation; as a matter of fact, 1 mM  $\text{Ca}^{++}$  totally inhibited its activity (Paston et al., 1968).

The other PLC enzyme which degraded phosphatidylcholine and sphingomyelin requires 5-10 mM  $\text{Ca}^{++}$  for optimal activity (Takahashi et al., 1974).

The PLC used in this work was assayed by Sigma. Their assay method involves the utilization of 5 mM  $\text{CaCl}_2$ .  $\text{CaCl}_2$ , of course, would inactivate the sphingomyelin-specific lipase and prevent its detection. Thus, there is the possibility of having purchased samples contaminated by PLC other than phosphatidylcholine-specific PLC.

When a Ringer-Locke solution with a normal (2 mM)  $\text{Ca}^{++}$  component was used, the PLC would be fully active and the data unaffected by the sphingomyelin-specific PLC. On the other hand, low  $\text{Ca}^{++}$  solution containing .235 mM of  $\text{Ca}^{++}$ , would allow for the expression of the sphingomyelin-specific PLC.

The ionic sensitivity of the two PLCs may be indicative of different mechanisms involved in the two methods for quantal content measurements. It was observed that in the preparation perfused with low  $\text{Ca}^{++}$ /high  $\text{Mg}^{++}$  Ringer solution, the intracellular recordings were very unstable. Because of depolarization and/or muscle fasciculation, it was very difficult to maintain the cell's integrity. This observation appears to substantiate the membrane stabilizing properties of  $\text{Ca}^{++}$ . Albuquerque et al. (1968) showed that by increasing the  $\text{Ca}^{++}$  concentration of the Ringer solution to 15 mM, they were able to reverse

PLC's inhibitory effect upon muscle action potential generation. This finding suggests the significance of this cation for membrane stability, as well as, its involvement in hydro-phylic phospholipid head groups during passive ion transport in the electrogenic membrane (Goldman, 1964).

### Endplate Potential (EPP)

The form of the EPP, recorded post-synaptically with an intracellular electrode, depends on two processes: pre-synaptic activation, resulting in neurotransmitter release, leading to the generation of the EPP by the post-synaptic membrane. For a true representation of the communication between the pre-synaptic and post-synaptic structures, it is essential to have integrity of the post-synaptic membrane. Thus, the amplitude of the EPPs depends upon the amount of ACh released, the activity of AChE, the passive membrane properties of the post-synaptic membrane and the availability of excitable, ACh receptor-ionic channel complexes. The results of the present work indicate that PLC increases the quantal content, implying an increase in the number of ACh molecules released per pre-synaptic stimulation. Assuming that the other variables are constant, the increase of the number of ACh molecules in the synaptic cleft may lead to potentiation of the EPP by increasing the number of activated ionic channels. Hartzell et al. (1975), using a snake skeletal muscle preparation and



iontophoretic ACh application, showed that post-synaptic potentiation occurred only when there was inhibition of AChE. They proposed that ACh mediated post-synaptic potentiation occurs only when ACh quanta are not isolated and are allowed to diffuse laterally. These isolating properties were attributed to AChE. PLC may alter the effect of AChE activity on ACh. By changing the composition of membrane phospholipids, the microenvironment of AChE molecules may be rendered less active or inactive resulting in an enhanced response. In the present work, PLC's anti-AChE effect is further supported by recordings in both the normal Ringer solution and the low  $\text{Ca}^{++}$ /high  $\text{Mg}^{++}$  solution where there was a significant prolongation of the EPP's decay-phase. To further investigate the potentiation of the EPP by the activity of PLC and the anti-AChE mechanism, possibly involved in this activity, the experimenter evaluated the action of PLC on bath-applied ACh, pressure-generated ACh potentials and the carbachol responses.

#### Acetylcholine Potential (ACh Potential)

In the EPP study, the pre-synaptic structures were among the most important variables. In order to eliminate their influence, ACh was applied independently of the pre-synaptic release. Nevertheless, because there are pre-synaptic structures, one cannot totally eliminate their influence; as mentioned earlier, PLC has a significant

pre-synaptic effect. As in the EPP studies, the ACh potential studies demonstrate amplitude potentiation, implying that PLC has a post-synaptic effect. This amplitude potentiation, again, could be attributed to AChE inhibition. There is, however, another possibility: since the ACh is applied into the bath, there is no restriction on its diffusion. This may lead to the activation of the extrajunctional receptors, whose depolarization might influence junctional depolarization. This observation agrees with the studies of Harborne et al. (1978), who showed that PLC unmasked extra-junctional spare receptors. Because of the ejection electrode's position and the response's time-course, pressure applied ACh is more like a synaptic than a extra-synaptic response. Again, in the case of the bath-applied preparation, PLC potentiates the ACh amplitude. In regard to this effect, one must not forget the possible direct-receptor sensitizing phenomenon suggested in the early 1950s by Koppányi and Karczmar. In recent years, a large body of evidence has been gathered that gives strong support for the sensitizing phenomenon. Experiments involving sympathetic ganglion cells with nicotinic responses, amphibian (Akasu et al., 1981) and mammalian neuromuscular preparations (Ewald, 1976) showed potentiation with exogenous (Lamber & Parsons, 1970), as well as endogenous (Akasu et al., 1981) substances.

To eliminate the influence of AChE upon the response, a carbachol potential was used. Carbachol is a nicotinic agonist, insensitive to AChE activity (Goodman et al., 1980). In this paradigm, PLC's effect on the carbachol response was very similar to that in the ACh potential. The carbachol potential's amplitude was increased by 69%, whereas, the amplitude of the ACh response increased 82%. This quantitative difference between the two sets of data may support the hypothesis that PLC's inhibition of AChE contributes to its action.

#### Volatage Clamp

The voltage clamp studies evaluate the influence of PLC upon the ACh receptor-ionic channel complexes. There was a significant increase in the EPC amplitude by the action of PLC. Since this paradigm involves pre-synaptic structures, the amplitude potentiation may be attributed to the pre-synaptic increase in ACh release (Hartzell et al., 1975). Anti-AChE action may also play a role in PLC activity (Gage et al., 1968). The carbachol potential studies, however, suggest that PLC's anti-AChE role may not be the sole contributor to EPC amplitude enhancement. It is not unreasonable to speculate that PLC may have an effect upon the post-synaptic membrane, influencing the function of ACh receptor-ionic channel complexes. This effect was observed in the analysis of EPP waveforms where the

decay-phase was prolonged. The analysis of the EPC waveforms revealed that the decay-phase was also significantly prolonged. Gage et al. (1974) found an effect very similar to those presented in the present work. In their studies of aliphatic alcohols on the conductance change caused by ACh, they found that ACh increased the current amplitude without changing the exponential decay; however, the decay-time was prolonged. The voltage sensitivity of these channels was unchanged. Gage proposed that alcohol molecules become incorporated into and alter the function of the channel's microenvironment slowing the gating processes of individual channels. The mechanism proposed as an explanation for this phenomenon was an increase in the membrane's dielectric constant.

The concept of an altered membrane dielectric constant is clouded by the complex physics of dielectrics; thus, the mathematic model will not be discussed in detail. Simply, the dielectric constant is the ratio between measured capacitance in a capacitor with a given material between its plates, and the capacitance of a perfect capacitor with a vacuum between its plates. Every material has a dielectric constant; they range from 6 for porcelain to 2.9 for beeswax to 1.0 for stream water (The Handbook of Chemistry and Physics, 65th Edition, 1984-1985, p. E-31-55, CRC Press). Direct studies have shown that the dielectric constant may play a role in the functional properties of membranes.

After the dielectric constant of the membrane increases through the incorporation of chlorinated hydrocarbon (1-chlorodecane), there was an enhanced membrane permeability (Dilger et al., 1979). If PLC action upon the junctional membranes alters the membrane dielectric constant, then, one would expect to observe changes in membrane permeability and/or capacitance.

The present studies do not show a significant change in the membrane resistance. The time constant also appears unchanged, implying no observable change in the capacitance. Under these circumstances, an explanation is difficult to find. If one assumes that the dielectric constant is indeed altered, then the capacitance must be involved. This involvement, however, may be small enough to be undetected, but large enough to influence the decay-rate (Gage et al., 1975).

Another possibility involves the vertical displacement hypothesis of Borochoy and Shinitzky (1976) (see the introduction for details). A phospholipase, like PLA<sub>2</sub>, was found to decrease membrane fluidity (Liu et al., 1983). Phospholipase C may act in a similar way. An increase in membrane rigidity may lead to vertical displacement of the newly formed receptors. This process may enhance the new receptor's arrival at the surface, resulting in a larger

density of receptors. This has been shown by binding studies of cholinergic receptors following cholesterol treatment of the membranes (Hershkowitz, 1982).

The altered morphology and physiology of post-synaptic membrane's may result from rigidification. The post-junctional membrane is a heterogeneous structure in both receptor distribution and morphology. The top of the post-junctional membrane has a high density of filamentous structures (Brisk, 1966) and is packed with receptors. The receptors at the bottom of the folds, however, are much less dense (10% of the top) and are indistinguishable from the extrajunctional receptors (Salpeter et al., 1983). These two receptor types differ. It appears that the unit conductance of the junctional receptor-ionic channel complexes (RICC) is 20-30 pS while extracellular RICCs exhibit a unit conductance of 10 pS; also the opening time for junctional RICCs is 2-3 times shorter than the extrajunctional RICCs (Dreyer et al., 1976; Dreyer et al., 1976). Thus, after modifying the post-synaptic architecture by PLC application, one may observe a less defined structural organization, allowing ACh to reach a heterogeneous population of junctional and extrajunctional receptors.

## Electrotonic Potential

A hyperpolarizing pulse was used to check the effects of PLC, in concentrations of 0.1  $\mu$ /ml, upon the neuromuscular preparation used over the duration of drug application. When the preparation survived the duration of the experiment, there was no significant change in the resistance or the waveform. An unusually high number of preparations were not able to be maintained throughout the experiment (70%). Though the current/voltage relationship was not obtained, it is possible that the hyperpolarizing current had an effect upon the activity of PLC.

## CONCLUSION

This study has shown that PLC from Clostridium welchii has a complex effect upon the neuromyal junction of a mouse, phrenic nerve-diaphragm preparation. Generally, in concentrations of .1 u/ml applied for 15-30 minutes at 30<sup>0</sup> C, this enzyme did not show a post-synaptic depolarizing effect; higher concentrations caused a depolarizing effect which appeared to be dependent upon the duration of application. The depolarizing effect was not reversible with the wash. Heat deactivated PLC, in a concentration of 25 u/ml, had no depolarizing effect.

Pre-synaptically, PLC, .1 u/ml, caused a 64% increase in the frequency of mEPPs. This mechanism may be Ca<sup>++</sup> dependent (Ohta and Karczmar, 1981). The quantal content increased in both the normal Ringer and low Ca<sup>++</sup>/high Mg<sup>++</sup> Ringer, 23% and 32%, respectively. This difference may be due to PLC's sensitivity to Ca<sup>++</sup>. There was no observed effect of PLC at .1 u/ml upon the compound axonal potential.

Post-synaptically, both the ACh potential and the carbachol potentials were enhanced by PLC. These results are in agreement with those of Watson et al. (1976) and Harborne et al. (1978), who proposed that PLC may unmask the spare receptors. Other augmenting mechanisms may involve a direct sensitization of receptor-ionic channel complexes or anti-cholinesterase activity. The electrotonic potential



experiments showed no PLC effect at .1 u/ml on the waveform; however, both the EPP and EPC decay-times were increased. This increase in the EPP and EPC decay-times suggests the involvement of PLC in the alteration of channel kinetics. Since decay-time is an indicator of the average channel lifetime, prolongation of this phase implies an enhanced average time during which a channel is open. The mechanism involved may be related to the specific biochemical action of PLC. Since most of the phosphatidylcholine molecules are located in the outside layer of the membrane and phosphatidylcholine is an important component of the membrane, PLC activity might result in perturbation of this system. This perturbation might lead to the modification of membrane fluidity which in turn might be correlated to the observed channel effects.

Considering the fact that PLC had influence upon both pre- and post-synaptic events, it is not surprising to see PLC's influence upon the "mixed effects". The mEPP amplitude was enhanced by 12%, the EPP amplitude was enhanced by 24% and the EPC was increased by 12%.

This study points to the importance of membrane phospholipids in signal processing. Although phospholipid membranes may not play a direct role in carrying ionic species during signal generation, phosphatidylcholine, in particular, appears to play an integral role in the maintenance of the protein's functional integrity.

## REFERENCES

- Abbs, E.T. and Joseph, D.M. (1981) The effects of atropine and oxotremorine on acetylcholine release in rat phrenic nerve-diaphragm preparation. *Br. J. Pharmacol.* 73:481-483.
- Adams, P.R. (1975). A model for the procaine endplate current. *J. Physiol.* 246:61-65.
- Adams, P.R. and Sakmann, B. (1978). Decamethonium both opens and blocks endplate channels. *Proc. Nat. Acad. Sci.* 75:2994-2998.
- Adler, M and Albuquerque, E. (1976). An analysis of the action at atropine and scopolamine on the end-plate current of frog sartorius muscle. *J. Pharmacol. Exp. Ther.* 196:360-372.
- Akasu, T. and Karczmar, A.G. (1980). Effect of anticholinesterases and of sodium fluoride on neuromyal desensitization. *Neuropharmacol.* 19:393-403.
- Albuquerque, E.X.; Eldefrawi, A.T.; Eldefrawi, M.E. and Tsai, M.C. (1978). Amentadine: Neuromuscular blockade by suppression of ionic conductance at the acetylcholine receptor. *Science* 199: 788-790.
- Albuquerque, E.X. and Thesleff, S. (1968). The effect of calcium on the skeletal muscle membrane after treatment with phospholipase C. *Acta Physiol. Scand.* 72:310-321.
- Albuquerque, E.X. and Thesleff, S. (1966). Influence of phospholipase C on some electrical properties of the skeletal muscle membrane. *J. Physiol.* 190:123-137.
- Anderson, C.R. and Stevens, C.F. (1973). Voltage clamp analysis of acetylcholine produced endplate current fluctuations at frog neuromuscular junction. *J. Physiol.* 235:655-691.
- Anwyl, R. and Narahashi, T. (1977). Action at colchicine, cytochalasin B, sodium thiopental, and decanol on the acetylcholine receptor. *Neurosci. Abstr.* 3:369.
- Augustyn, J.M. and Elliot, W.B. (1970). Isolation of a phospholipase A from Agkistrodon piscivorus venom. *Biochim. Biophys. Acta* 206:98-108.
- Banker, B.Q., Kelly, S.S. and Robbins, N. (1983). Neuromuscular transmission and correlative morphology in young and old mice. *J. Physiol.* 339:355-377.

- Barenholz, Y. (1985). Sphingomyelin-lecithin balance in membranes. In: Physiology of Membrane Fluidity, Vol. I.
- Barnard, E.A.; Wieckowski, J. and Chiu, T. (1971). Cholinergic receptor molecules and cholinesterase molecules at skeletal muscle junction. *Nature* 239:207-209.
- Barron, E.S.G.; Bartlett, G.R. and Miller, A.B. (1948). Effects of nitrogen mustard on enzymes and tissue metabolism. *J. Exp. Med.* 87:489-501.
- Barstad, J.A.B. and Lilleheil, G. (1968). Transversally cut diaphragm preparation from rat. *Arch. Int. Pharmacodyn.* 175:372-390.
- Beam, K.D. (1976). A voltage-clamp study of the effects of two lidocaine derivatives on the timecourse of end-plate currents. *J. Physiol.* 258:279-300.
- Bentley, P.J. (1968). Amiloride: A potent inhibitor of sodium transport across the toad bladder. *J. Physiol.* 195:317-330.
- Beranek, R. and Vyskocil, F. (1967). The action of tubocurarine and atropine on the normal and denervated rat diaphragm. *J. Physiol.* 188:53-66.
- Betty, Q.; Banker, S.; Kelly, S. and Robbins, N. (1982). Neuromuscular transmission and correlatives morphology in young and old mice. *J. Physiol.* 339:335-375.
- Bienvenue, A.; Rousset, A.; Kato, G. and Devaux, P.F. (1977). Fluidity of lipids next to the acetylcholine receptor Protein of Torpedo membrane fragments. *Biochem.* 16:841-845.
- Birks, R.I. (1966). The fine structure of motor-endings at frog myoneural junction. *Ann. NY Acad. Sci.* 135:8-26.
- Birks, R.I. and Cohen, M.W. (1968). The influence of internal sodium on the behavior of motor-endings. *Proc. of Roy. Soc.* 170:401-421.
- Birks, R.I. and Cohen, M.W. (1969). The action at sodium pump inhibitors on neuromuscular transmission. *Proceeding at Royal Soc.* 170:381-399.
- Bligh, J. (1952). The level of free choline in plasma. *J. Physiol.* 117:234-240.

- Blusztajn, J.K. and Wurtman, R.J. (1983). Choline and cholinergic neurons. *Science* 221:614-619.
- Borochoy, H. and Shinitzky, M. (1976). Vertical displacement of membrane proteins mediated by changes in microviscosity. *Proc. Natl. Acad. Sci.* 73:4526-4530.
- Bostock, H. and Sears, R. (1976). Continuous conduction in demyelinated mammalian nerve fibers. *Nature* 263:786-787.
- Bowden, R.E.M. and Duchon, L.W. (1976). The anatomy and pathology of the neuromuscular junction. In: *Neuromuscular junction. Handbook of experimental Pharmacology*. Vol. 42, pp. 23-97.
- Bowman, W.C. (1980). *Pharmacology of neuromuscular function*. J. Wright and Sons.
- Boyd, I.A. and Davey, P. (1968). *Composition of peripheral nerves*. Livingstone, Edinburgh.
- Boyd, I.A. and Martin, A.R. (1956). The end-plate potential in mammalian muscle. *J. Physiol.* 132:74-91.
- Boyd, I.A. and Martin, A.R. (1959). Membrane contents of mammalian muscle fibers. *J. Physiol.* 147:450-457.
- Bremer, J. and Greenberg, D.M. (1961). Methyl transferring enzyme system of microsomes in biosynthesis of lecithin. *Biochem. Biophys. Acta* 46:205-216.
- Bremer, J. (1969). Pyruvate dehydrogenase, substrate specificity and product inhibition. *Eur. J. Bioch.* 8:535-540.
- Brigant, J.L. and Mallart, A. (1982). Presynaptic currents in mouse motor ending. *J. Physiol.* 333:619-636.
- Brismar, T. (1980). Potential clamp analysis of membrane currents in rat myelinated nerve fibers. *J. Physiol.* 298:171-184.
- Butler, K.W. and Schneider, H. (1973). The effects of local anesthetics on lipid monolayers. *Arch. Biochim. Biophys.* 154:548-554.
- Cahalan, M. (1978). Voltage clamp studies on the node of Ranvier. In: *"Physiology and Pathobiology of Axons"*, N.Y. Raven Press, 155-168.

- Casu, A.; Pala, V.; Monacelli, R. and Manni, G. (1971). Structure of membranes. *Ital. J. Biochem.* 20:166-178.
- Chalifour, R.J. and Kanter, J.N. (1980). Microsomal phospholipase D of rat brain and lung tissues. *Biochem. Biophys. Res. Comm.* 96:742-747.
- Chalifour, R. and Kanter, J.N. (1982). Fatty acid activation and temperature perturbation of rat brain microsomal phospholipase D. *J. Neurochem.*, 39:299-305.
- Chang, C.G.; Huang, M.C. and Lee, C.Y. (1973). Mutual antagonism between barbituric acid and  $\alpha$ -bungarotoxin. *Nature* 243:166-167
- Chin, J.H. and Goldstein, D.B. (1977). Drug tolerance in biomembranes. *Science* 196:684-689.
- Chin, J.H. and Goldstein, D.B. (1977). Effect of low concentrations of ethanol on fluidity of erythrocytes and brain membranes. *Mol. Pharmacol.* 13:435-441.
- Chin, J.H. and Goldstein, D.B. (1980). Effects of aliphatic alcohols and aldehydes on fluidity of spin-labelled-synaptosomal plasma membranes. *Adv. Exp. Med. Biol.* 132:1715-1719.
- Chin, J.H. and Goldstein, D.B. (1981). Membrane-disordering action of ethanol: variation in membrane cholesterol content and depth of spin-labelled probe. *Mol. Pharmacol.* 19:425-431.
- Chiu, S.Y. and Ritchie, J.M. (1980). Potassium channels in nodal and internodal axonal membrane of mammalian myelinated fibers. *Nature* 284:170-171.
- Chiu, S.Y. and Ritchie, J.M. (1979). Quantitative description of membrane currents in rabbit myelinated nerve. *J. Physiol.* 292:149-166.
- Collier, B. and Katz, H.S. (1974). ACh synthesis from recaptured choline by a synaptic ganglion. *J. Physiol.* 230:639-655.
- Cooper, R.A. (1977). Abnormalities of cell membrane fluidity in the pathogenesis of disease. *N. Engl. J. Med.* 197:371-378.
- Corda, D.; Pasternak, C. and Shinitzky, M. (1982) Increase in lipid microviscosity at vesicles upon creation of membrane potential. *J. Membrane Biol.* 65:232-237.

- Coria, F.; Berciano, J. and LaFazga, M. (1984). Axon membrane remodeling in the lead-induced demyelinating neuropathy of the rat. *Brain Res.* 291:369-373.
- DeHass, G.H.; Postema, N.M.; Nicuwenhuizen, W. and Van Deenen, L.L.M. (1968). Purification and properties of phospholipase A from porcine pancreas. *Biochim. Biophys. Acta* 159:103-117.
- Dekruijff, B.; Van Dijck, B.W.M.; Demel and R.A.; Schuijff, A. (1974). Non-random distribution of cholesterol in phosphotidylcholine bilayers. *Biochim. Biophys. Acta* 356:1-11.
- DelCastillo, J. and Katz, B. (1954). Statistical factors involved in neuromuscular facilitation and depression. *J. Physiol.* 135:574-585.
- DePont, J.J.; Van Prooijen-Van Eden, A. and Bonting, S.L. (1978). Role of negatively charged phospholipids in highly purified (Na<sup>+</sup>-K<sup>+</sup>) ATPase from rabbit kidney outer medulla. *Biochim. Biophys. Acta* 508:464-477.
- Dickens, B.F. and Thompson, G.A. (1982). Phospholipid molecular species alteration in microsomal membranes as initial key step during cellular acclimation to low temperature. *Biochem.* 21:3604-3610.
- Dilger, J.P. and McLaughlin, S.G.A. (1979). The dielectric constant of phospholipid bilayers and permeability of membranes to ions. *Science* 206:1196-1199.
- Dod, B.J. and Gray, G.M. (1968). The lipid composition of rat liver plasma membranes. *Biochim. Biophys. Acta* 150:397-403.
- Dreyer, F., Pepper, K. and Sterz, R. (1978). Determination of dose response curves by quantitative iontophoresis at frog neuromuscular junction. *J. Physiol.* 281:395-419.
- Dreyer, F.; Miller, D.; Peper, R. and Sterz, R. (1976). The M. amolyoideus of the mouse as a convenient mammalian muscle preparation. A study of junctional - extrajunctional acetylcholine receptors by noise analysis and cooperativity. *Pflugers Arch.* 367:115-122.
- Dreyer, F.; Walther, C. and Peper, K. (1976). Junctional and extrajunctional acetylcholine receptors in normal and developed frog muscle fibers. *Pflugers Arch.* 366:1-9.

- Dunant, Y. and Israel, M. (1985). The release of acetylcholine. *Sci. Am.* 252:58-65.
- Eccles, J.C.; Katz, B. and Kuffler, S.W. (1942). Effect of eserine on neuromuscular transmission. *J. Neurophys.* 5:211-230.
- Edelman, G.M. (1976). Surface modulation in cell recognition and cell growth. *Science* 192:218-220.
- Einset, E. and Clark, W.L. (1958). The enzymatically catalyzed release of choline from lecithin. *J. Biol. Chem.*, 213:703-715.
- Ekstrom, J. and Emmelins, N. (1971). Movement of choline acetyltransferase in axons disconnected from their cell bodies. *J. Physiol.* 216:247-256.
- Elmqvist, D. and Feldman, D.S. (1966). Influence of ionic environment on acetylcholine release from the motor nerve terminals. *Acta Physiol. Sci.* 67:34-42.
- Elmqvist, D. and Quastel, D.M.J. (1965). A quantitative study of end-plate potentials in isolated human muscle. *J. Physiol.* 178:505-529.
- Enomoto, K. and Maeno, T. (1981). A microcomputer system for on-line analysis of the end-plate potential data. *Brain Research Bull.* 7:97-99.
- Fambrough, D.M. (1979). Control of acetylcholine receptors in skeletal muscle. *Physiological Rev.* 59:165-227.
- Fatt, P. and Katz, B. (1951). An analysis of the endplate potential recorded with an intracellular electrode. *J. Physiol.* 115:320-350.
- Feltz, A. and Trautmann, A. (1982). Desensitization at the frog neuromuscular junction: A biphasic process. *J. Physiol.* 322:257-272.
- Fertuck, H.C. and Salpeter, M.M. (1974). Localization of ACh receptors at mouse motor endplates. *Proc. Natl. Acad. Sci.* 71:1376-1378.
- Fonnum, F. (1973). Recent developments in biochemical investigations of cholinergic transmission. *Brain Research* 62:497-507.
- Fontaine, R.M.; Harris, R.A. and Schroeder, F. (1980). Aminophospholipid asymmetry in murine synaptosomal plasma membranes. *J. Biol. Chem.* 244:5528-5536.

- Frazier, D.T.; Narahashi, T. and Yamaoka, M. (1970). The site of action and active form of local anesthetics. *J. Pharmacol. Exp. Ther.* 171:45-51.
- Futerman, A.H.; Low, M.G. and Silman, I. (1983). A hydrophobic dimer of acetylcholinesterase from Torpedo californica electric organ is solubilized by phosphatidylinositol-specific phospholipase C. *Neuroscience Lett.* 40:87-89.
- Gage, P.W. (1976). Generation of end-plate potentials. *Physiol. Rev.* 56:177-247.
- Gage, P.W. and Armstrong, C.M. (1968). Miniature end-plate currents in voltage-clamped muscle fiber. *Nature* 218:363-365.
- Gage, P.W. and Hamill, M. (1981). Effects of anesthetics on ion channels in synapses. *Int. Rev. Physiol.* 25:1-45.
- Gage, P.W. and McBurney, R.N. (1975). Effect of membrane potential, temperature and neostigmine on the conductance change at the toad neuromuscular junction. *J. Physiol.* 244:375-407.
- Gage, P.W.; McBurney, R.N. and Schneider, G.T. (1975). Effects of some aliphatic alcohols on the conductance change caused by quantum of acetylcholine at the toad end-plate. *J. Physiol.* 244:409-429.
- Gallagher, J.P. (1972). Ph.D. Dissertation. Action of catechol and phenol. Loyola University.
- Gallagher, J.P. and Karczmar, A.G. (1973). A direct facilitatory action for dopamine at neuromuscular junction. *Neuropharmacol.* 12:783-791.
- Ganguly, D. and Das, M. (1979). Effects of oxotremorine demonstrate presynaptic muscarinic and dopaminergic receptors on motor nerve terminals. *Nature* 278:645-646.
- Gatt, S. and Barenholz, Y. (1973). Enzymes of complex lipid metabolism. *Ann. Rev. Biochem.* 42:61-90.
- Georgescauld, D. and Dclohier, A. (1978). Transient fluorescence signals from pyrene labelled pike nerves during action potential. *Biochem. Biophys. Res. Commun.* 85:1186-1190.
- Ginsborg, B.L. (1960). Spontaneous activity in muscle fibers of the chick. *J. Physiol.* 150:707-717.



- Ginsborg, B.L. and Hirst, G.D.S. (1972). The effects of adenosine on the release of the transmitter from the phrenic nerve. *J. Physiol.* 224:629-645.
- Goldman, D.E. (1964). A molecular structural basis for the excitation properties of axons. *Biophys. J.* 4:167-188.
- Goodman, A.; Goodman, L.S. and Gilman, A. (1980). *The Pharmacological Basis of Therapeutics.* Macmillan Publishing Co.
- Gundersen, C.B. and Jenden, D.J. (1980). Oxotremorine does not enhance acetylcholine release from rat diaphragm preparation. *Br. J. Pharmacol.* 70:8-10.
- Hall, A.W. (1973). Multiple forms of acetylcholinesterase and their distribution in end-plate region of rat diaphragm. *J. Neurobiol.* 4:343-361.
- Hall, Z.W. and Kelly, R.B. (1971). Enzymatic detachment of endplate acetylcholinesterases from muscle. *Nature* 237:62.
- Harborne, J.; Smith, M.E. and Jones, R. (1978). The effect of hydrolytic enzymes on the acetylcholine sensitivity of the skeletal muscle cell membrane. *Pflugers Arch.* 377:147-153.
- Harris, R.A. and Schroeder, F. (1982). Effects of barbiturates and ethanol on the physical properties of brain membranes. *J. Pharmacol. Exp. Ther.* 223:424-432.
- Harris, R.A. and Schroeder, F. (1981). Ethanol and physical properties of brain membranes. *Mol. Pharmacol.* 20:128-137.
- Hartzell, H.C.; Kuffler, S.W. and Yoshikami, . (1975). Postsynaptic potentiation: interaction between quantal of acetylcholine at the skeletal muscle synapse. *J. Physiol.* 251:427-463.
- Heron, D.S.; Israel, M. and Shinitzky, M. (1981). Lipid induced modulation of opiate receptors in mouse brain membranes. *Eur. J. Pharmacol.* 72:361-367.
- HersHKovitz, M.; Zwiers, H. and Gispen, W.H. (1982). The effect of ACTH on rat brain synaptic plasma membrane lipid fluidity. *Biochim. Biophys. Acta* 692:495-501.
- Hille, B. (1967). Quaternary ammonium ions that block the potassium channel of nerves. *Biophys. Soc. Abstr.* 19:12.

- Hille, B. (1967). The selective inhibition of delayed potassium currents in nerve by tetraethylammonium. *J. Gen. Physiol.* 50:1287-1302.
- Hille, B. (1985). Ionic channels at excitable membranes. Sinauer Ass.
- Hinzen, D.H. and Tave, L. (1977). Membrane properties of *Aplysia* neurons intracellularly injected with phospholipases A and C. *J. Physiol.* 268:21-34.
- Hirata, F. and Axelrod, J. (1980). Phospholipid methylation and biological signal transmission. *Science* 209:1082-1084.
- Hitzmann, R.J. and Johnson, D.A. (1983). Developmental changes in synaptic membrane lipid composition and fluidity. *Neurochem. Res.* 8:121-135.
- Hodgkin, A.L. and Huxley, A.F. (1952a). The component of membrane conductance in the giant axon of *Loligo*. *J. Physiol.* 116:449-472.
- Hodgkin, A.L. and Huxley, A.F. (1952b). The components of membrane conductance in the giant axon of *Loligo*. *J. Physiol.* 116:473-496.
- Hodgkin, A.L. and Huxley, A.F. (1952c). The dual effect of membrane potential on sodium conductance in the giant axon of *loligo*. *J. Physiol.* 116:497-506.
- Hodgkin, A.L. and Huxley, A.F. (1952d). A quantitative description of membrane current and its application to conduction and excitation in nerve. *J. Physiol.* 117:500-544.
- Hofer, P.; Fringeli, U.P. and Hopff, W.H. (1984). Activation of acetylcholinesterase by monovalent ( $\text{Na}^+$ ,  $\text{K}^+$ ) and divalent ( $\text{Ca}^{++}$ ,  $\text{Mg}^{++}$ ) cations. *Biochem.* 23:2730-2734.
- Horn, A.S.; Lambert J.J. and Marshall, I.G. (1979). A comparison of the facilitatory action of 4-aminopyridine methiodide and 4-aminopyridine on neuromuscular junction. *British J. Pharmacol.* 65:53-62.
- Hostetler, K.Y. and Hall, L.B. (1980). Phospholipase C activity of rat tissues. *Biochem. Biophys. Res. Comm.* 96:388-394.
- Hubbard, J.I. and Wills, W.D. (1962). Hyperpolarization of mammalian motor nerve terminals. *J. Physiol.* 163:115-137.

- Hubbard, J.I. and Schmidt, R.F. (1962). An electrophysiological investigation of mammalian motor nerve terminals. *J. Physiol.* 166:145-167.
- Hubbard, J.I.; Jones, S.F. and Landau, E.M. (1968). On the mechanism by which calcium and magnesium affect the release at transmitter. *J. Physiol.* 196:75-86.
- Hubbard, J.I. (1973). Microphysiology of vertebrate neuromuscular transmission. *Physiol. Rev.* 53:674-723.
- Hubbard, R.E. and Garratt, C.J. (1980). The composition and fluidity at adipocyte membranes prepared from young and adult rats. *Biochim. Biophys. Acta* 600:701-711.
- Hubbell, W.L.; Metcalfe, J.C. and McConnell, H.M. (1970). The interaction of small molecules with spin-labelled erythrocyte membranes. *Biochim. Biophys. Acta* 219:415-425.
- Huxley, A.F. and Stampfi, R. (1949). Evidence for saltatory conduction in peripheral myelinated nerve fibers. *J. Physiol.* 108:315-339.
- Israel, M.; Lesbats, B. and Manaranche, R. (1972). Variations d-acetylcholine en relation avec l'evolution de la decharge pendant la stimulation de l'organe electrique de la Torpille. *C.V. Lebd. Acad. Sci. (Paris)* 275:2957-2960.
- Israel, M.; Dunant, Y. and Manaranche R. (1979). The present status of the vesicular hypothesis. *Prog. Neurobiol.* 13:237-275.
- Johnson, E.W. and Wernig, A. (1971). The binomial nature of transmitter release of the crayfish neuromuscular junction. *J. Physiol.* 218:757-767
- Junge, D. (1981). Nerve and muscle excitation. Sinauer Ass. Inc.
- Kaibara, K.; Kuba, K.; Koketsu, K. and Karczmar, A.G. (1978). The mode of action of fluoride ions on neuromuscular transmission in frogs. *Neuropharmacol.* 17:335-339.
- Karczmar, A.G. (1966). Neuromuscular pharmacology. *Ann. Rev. Pharmacol.* 7:241-276.
- Karlin, A. (1980). Molecular properties of nicotinic ACh receptors. In: *The Cell Surface and Neuronal Function*. N.Y. Elsevier/North Holland, 191-260.

- Kates, M. (1954). Lecithinase systems in sugar beet, spinach, cabbage and carrot. *Can. J. Biochem. Physiol.*, 32:571-583.
- Katz, B. (1966). *Nerve, muscle and synapse*. McGraw-Hill, New York.
- Katz, B. (1969). The release of neural transmitter substances. Charles C. Thomas, Publ., Springfield, IL.
- Katz, B. and Miledi, R. (1978). A re-examination of curare action at the motor endplate. *Proc. R. Soc. London* 203:119-133.
- Katz, B. and Miledi, R. (1970). Membrane noise produced by acetylcholine. *Nature* 226:962-963.
- Katz, B. and Miledi, R. (1965). Propagation of electric activity in motor nerve terminals. *Proc. Roy. Soc.* 161:453-482.
- Katz, B. and Thesleff, S. (1957). A study of desensitization produced by acetylcholine at motor endplate. *J. Physiol.* 138:63-80.
- Katz, B. and Thesleff, S. (1957). On the factors which determine the amplitude of the mEPPs. *J. Physiol.* 137:267-278.
- Khodorov, B.I.; Peganov, E.M.; Revenko, S.V. and Shishkova, L.D. (1975). Sodium currents in voltage clamped nerve fiber of frog under the combined action of batrachotoxin and procaine. *Brain Res.* 84:541-546.
- Kistler, J.; Stroud, M.W. and Klymkowsky, R.A. (1982). Structure and function of acetylcholine receptor. *Biophys. J.* 37:371-383.
- Kistler, J. and Stroud, R.M. (1981). Crystalline arrays of membrane-bound ACh receptor. *Proc. Natl. Acad. Sci.* 78:3678-3682.
- Kita, H. and Van der Kloot, W. (1974). Calcium ionophore X-537A increases spontaneous and phasic quantal release of ACh at frog neuromuscular junction. *Nature* 250:658-660.
- Koelle, G.B.; Davis, R. and Gromadski, C.G. (1967). Electron microscope localization of cholinesterases by means of gold salt. *Ann. N.Y. Acad. Sci.* 144:613-625.

- Koeugh, K.M.W. and Thompson, W. (1972). Soluble and particulate forms of phosphoinositide phosphodiesterase in ox brain. *Biochim. Biophys. Acta* 270:324-336.
- Koh-ichi, E. and Takashi, M. (1981). A microcomputer system for on-line analysis of the endplate potential data. *Brain Res. Bul.* 7:97-99.
- Koppany, Theodore; Karczmar, Alexander G. and King, Theodore O. (1947). The effect of tetraethylpyrophosphate on sympathetic ganglionic activity. *Science* 106:492-493.
- Koppany, T. and Karczmar Alexander G. (1951). Contribution to the study of the mechanism of action of cholinesterase inhibitors. *J. Pharm. Exp. Therap.* 101:327-343.
- Koppenhofer, E. and Schmidt, H. (1968). Die Wirkung von skovpiongift auf die Ionenströme des Ranvierschen Schuurrings. *Pflügers Arch.* 303:150-161.
- Kordas, M. (1969). The effects of membrane depolarization on the time course of the endplate current in frog sartorius muscle. *J. Physiol.* 193:213-218.
- Korey, A. and Hamilton, J.T. (1974). The effects of replacement of  $K^+$  by caesium ions on neuromuscular blockade of the rat diaphragm in vitro. *Can. J. Physiol. Pharmacol.* 52:61-69.
- Kriebel, M.E. and Gross, C.E. (1974). Multimodal distribution of frog miniature end-plate potentials in adult denervated tadpole leg. *J. Gen. Physiol.* 64:85-103.
- Kriebel, M.E.; Lladós, R. and Matteson, D. (1976). Spontaneous subminiature end-plate potentials in mouse diaphragm muscle. *J. Physiol.* 262:553-581.
- Kriebel, M.E.; Matteson, D.R. and Pappas, S. (1978). Acetylcholine content in physiologically fatigued frog nerve muscle preparation. *Gen. Pharmac.* 9:229-234.
- Kuba, K. (1970). Effects of catecholamines on the neuromuscular junction in the rat diaphragm. *J. Physiol.* 211:551-570.
- Kuba, K.; Albuquerque, E.X. and Barnard, E.A. (1974). Study of the irreversible cholinesterase inhibitor, DFP, on time course of endplate currents in frog sartorius muscle. *J. Pharmacol. Exp. Ther.* 189:499-512.

- Kuba, K.; Chikazawa, K. and Koketsu, K. (1976). Novel action of a piperazine derivative on the endplate of the frog. *Jpn. J. Physiol.* 26:159-175.
- Kuhar, M.H. and Simon, I.R. (1974). ACh uptake. *J. Neurochim.* 22:1135-1138.
- Lambert, J. (1983). Drug-induced modification of ionic conductance at the neuromuscular junction. *Ann. Rev. Pharmacol. Toxicol.* 23:505-539.
- Lenard, Y. (1970). Protein and glycolipid components of human erythrocyte membranes. *Biochem.* 9:1129-1132.
- Liley, A.W. (1956). The effects of presynaptic polarization on the spontaneous activity at the mammalian neuromuscular junction. *J. Physiol.* 134:427-443.
- Linder, T.M. and Quastel, D.M.J. (1977). A voltage clamp study of the permeability change induced by quanta of transmitter at the mouse endplate. *J. Physiol.* 281:535-556.
- Lindstrom, J.; Merlie, J. and Yogeewarau, G. (1979b). Biochemical properties of ACh receptor subunits from *torpedo californica*. *Biochem.* 18:4465-4470.
- Lindstrom, J.; Walter, B. and Einarson, B. (1979). Immunochemical similarities between subunits acetylcholine receptors from *torpedo*, *electrophorus* and mammalian muscle. *Biochem.* 18:4470-4480.
- Liu, M.S.; Sonjay, G. and Yongsok, Y. (1983). Change in membrane lipid fluidity induced by phospholipase A activation. *Life Sci.* 33:1995-2002.
- Longenecker, H.E.; Hurlbut, W.P. and Mauro, A. (1970). Effects of black widow spider venom on the frog neuromuscular junction. *Nature* 225:701-703.
- MacIntosh, F.C. and Collier, B. (1976). Neurochemistry of cholinergic terminals. In: *Neuromuscular Junction. Handbook of Experimental Pharmacology*. Vol. 42, pp. 99-228.
- Magleby, K.L. and Stevens, C.F. (1972). Quantitative description of end-plate currents. *J. Physiol.* 223:173-197.

- Magleby, K.L. and Stevens, C.F. (1973). The effect of voltage on the time course of end-plate currents. *J. Physiol.* 223:151-171.
- Magleby, K.L. and Miller, D.C. (1981). Is the quantum of transmitter release composed of subunits? *J. Physiol.* 311:267-287.
- Mallart, A. (1984). Pre-synaptic currents in frog motor endings. *Pflugers Arch. Pharmacol.* 400:8-13.
- Manalis, R.S. (1977). Voltage dependent effect of curare on the frog neuromuscular junction. *Nature* 267:366-368.
- Marks, B.H. (1956). Effects of barbiturates on acetylation. *Science* 123:332-333.
- Martin, A.R. (1955). A further study of the statistical composition of the endplate potential. *J. Physiol.* 130:114-122.
- Martin, A.R. (1966). Quantal nature of synaptic transmission. *Physiol. Rev.* 46:51-70.
- Mastraugelo, C.J. and Trudell, J.R. (1978). Effect of clinical concentration of nalathane on phospholipid-cholesterol membrane fluidity. *Mol. Pharmacol.* 14:463-467.
- McArdle, J.J.; Angaut-Petit, D.; Mallart, A.; Bournaud, R.; Faille, L. and Brigant, J.L. (1981). Advantages of the triangularis sterni muscle of the mouse for investigations of synaptic phenomena. *J. Neurosci. Meth.* 4:109-115.
- McIlwain, D.L. and Rapport, M.M. (1971). The effects of phospholipase C on purified myelin. *Biochim. Biophys. Acta* 239:71-80.
- McLachlan, E.M. (1978). The statistics of transmitter release at chemical synapses. *Int. Rev. Physiol.* 17:49-117.
- McLachlan, E. and Martin, A.R. (1981). Non-linear summation of end-plate potentials in the frog and mouse. *J. Physiol.* 311:307-324.
- Michell, R.H. (1975). Inositol phospholipids and cell surface receptor function. *Biochim. Biophys. Acta* 415:81-147.
- Miyamoto, M.D. (1978). The action of cholinergic drugs on motor nerve terminals. *Pharmacol. Rev.* 29:221-247.

- Nachbaur, J.; Colbean, A. and Vignais, P.M. (1972). Distribution of membrane-confined phospholipase A in the rat hepatocyte. *Biochim. Biophys.* 274:426-446.
- Nachmansohn, D. and John, H.M. (1944). Inhibition of choline acetylase by alpha-keto acids. *Proc. Sc. Exp. Biol. Med.* 57:361-362.
- Narahashi, T. (1974). Chemicals as tools in the study of excitable membranes, *Physiol. Rev.* 54:814-889.
- Narahashi, T. and Tobias, J.M. (1964). Properties of axon membrane as affected by cobra venom, digitonin and proteases. *Am. J. Physiol.* 207:1441-1446.
- Neal, M.J.; Poluastzek, C.F. and Smith, I.C. (1976). Influence of anesthetics and cholinesteral on the degree of molecular organization and mobility of ox brain white matter. *Mol. Pharmacol.* 12:144-155.
- Neher, E. and Steinbach, J.H. (1978). Local anesthetics transiently block currents through single acetylcholine-receptor channels. *J. Physiol.* 277:153-176.
- Nelson, P.G. (1958). Effects of certain enzymes on node of Ranvier excitability with observations on submicroscopic structure. *J. Cell Comp. Physiol.* 52:127-145.
- Newkirk, J.D. and Waite, M. (1971). Identification of a phospholipase A1 in plasma membranes of rat liver. *Biochim. Biophys. Acta* 225:224-233.
- Newkirk, J.D. and Waite, M. (1973). Phospholipid hydrolysis by phospholipase A1 and A2 in plasma membranes and microsomes of rat liver. *Biochim. Biophys. Acta* 298:562-576.
- Ohta, Y.; Karczmar, G.S. and Karczmar, A.G. (1981). Phospholipids and amphibian neuromyal transmission. Eighth Internl. Congress of Pharmacol. July, 646.
- Ohta, Y. and Karczmar, A.G. (1981). Pre- and post-synaptic effects of phospholipase C on amphibian neuromyal transmission. *Fed. Proc.* 40:261.
- Ohta, Y. and Karczmar, A.G. (1984). Pre- and post-synaptic effects of phospholipase C on neuromyal transmission. (In preparation).
- Oshino, N. and Sato, R. (1972). The dietary control of the microsomal CoA desaturation enzyme system in rat liver. *Arch Biochem. Biophys.* 149:369-374.



- Paintal, A.S. (1965). Block of conduction in mammalian myelinated nerve fibers by low temperatures. *J. Physiol.* 180:1-19.
- Pang, K.Y. and Miller, K.W. (1978). Cholesterol modulates the effects of membrane pertubers in phospholipid vesicles and biomembranes. *Biochim. Biophys. Acta* 511:1-19.
- Paston, I; Macchia, V. and Katzen, R. (1968). A phospholipase specific for sphingomyelin from *Clostridium perfringens*. *J. Biol. Chem.* 243:3750-3755.
- Patan, W.D. and Wand, D.R. (1967). The margin of safety at neuromuscular transmission. *J. Physiol.* 191:59-90.
- Pestronk, A. and Drachman, D.B. (1980). Lithium reduces the number of acetylcholine receptors in skeletal muscle. *Science* 210:342.
- Philipson, K.D.; Frank, J.S. and Nishimoto, A. (1983). Effects of phospholipase C on the Na-Ca exchange and Ca permeability of cardiac sarcolemmal vesicles. *J. Biol. Chem.* 258:5905-5910.
- Potter, L.T. (1970). Synthesis, storage and release of <sup>14</sup>C-ACh in isolated rat diaphragm muscle. *J. Physiol.* 206:145-166.
- Randic, M. and Straughan, D.W. (1964). Antidromic activity in the rat phrenic nerve-diaphragm preparation. *J. Physiol.* 173:130-148.
- Raybink, D.M.; Bertsch, L.L. and Kornberg, A. (1972). A phospholipase in *Bacillus megaterium* unique to spores and sporangia. *Biochem.* 11:1754-1760.
- Ritchie, J.M and Rogart, R.B. (1977). Density of sodium channels in mammalian myelinated nerve fibers and nature of the axonal membrane under the myelin sheath. *Proc. Natl. Acad. Sci. (U.S.A.)* 74:211.
- de Robertis, E. (1964). Electron microscope and chemical study of binding sites of brain biogenic amines. *Prog. Brain Res.* 8:118-136.
- de Robertis, E. and Bennett, H.S. (1954). Submicroscopic vesicular component in the synapse. *Fed. Proc.* 13:35

- Roelfsen, B. and Schatzmann, H.J. (1977). The lipid requirement of the (Ca-Mg) - ATPase in the human erythrocyte membrane as studied by various highly purified phospholipases. *Biochim. Biophys. Acta* 464: 17-36.
- Rosenberg, P. (1970). Function of phospholipids in axons: Depletion of membrane phosphorus by treatment with Phospholipase C. *Toxicon* 8:235-243.
- Rosenberg, P. and Candrea, E. (1968). Maintenance of axonal conduction and membrane permeability in presence of extensive phospholipid splitting. *Biochem. Pharmacol.* 17:2033-2044.
- Rosenberg, P.; Jansson, J.E. and Gipenberg, J. (1977). Effects of halothane, thiopental and lidocaine on fluidity of synaptic membranes and artificial phospholipid membranes. *Anesthesiology* 46:322-326.
- Rouser, G. and Yamamoto, A. (1968). Curvilinear regression course of human brain lipid composition changes with age. *Lipid* 3:284-290.
- Ruhling, R.P. (1980). Statistical interpretation of research results. *Am. Lab.* 12:129-134.
- Sakai, M.; Swartz, E. and Woody, C.D. (1979). Controlled micro-release of pharmacological agents: measurements of volume ejected in vitro through fine tipped glass microelectrodes by pressure. *J. Pharmacol.* 18:209-213.
- Sakmann, B.; Patzak, J. and Neher, E. (1980). Single acetylcholine-activator channels show burst-kinetics in presence of desensitizing concentrations of agonist. *Nature* 286:71-73.
- Salach, J.I.; Turini, P.; Seng, R.; Hauber, J. and Singer, T.P. (1971). Phospholipase C of snake venoms. *J. Biol. Chem.* 246:331-339.
- Salpeter, M.D. and Harris, R. (1983). Distribution and turnover rate of acetylcholine receptors throughout the junction folds at a vertebrate neuromuscular junction. *J. Cell. Biol.* 96:1781-1785.
- Scandella, C.J. and Kronberg, A. (1971). A membrane-bound phospholipase A1 purified from Escherichia coli: *Biochem.* 10:4447-4456.

- Scanu, A.M.; Van Deenen, L.L.M. and DeHaas, G.H. (1969). Optical rotary dispersion and circular dichroism of phospholipase A2 and its symogen from porcine pancreas. *Biochim. Biophys. Acta* 181:471-473.
- Schlessinger, J. (1980). The mechanisms and role of hormone induced clustering of membrane receptors. *Trends Biochem. Sci.* 5:210-213.
- Schrijen, J.J.; Omachi, A.; Van Groningen-Luyben, W.A.H.M. and DePont, J.H.H.M. (1981). Studies on (K-H) - ATPase effects of phospholipase C treatment. *Biochim. Biophys. Acta* 649:1-12.
- Seyana, I. and Narahashi, T. (1976). Sodium conductance kinetics of squid axon membranes poisoned by grayanotoxin. *I. Biophys. J.* 16:87.
- Shanes, A.M.; Freygang, W.H. and Amatnick, E. (1959). Anesthetic and calcium action in the voltage clamped squid giant axon. *J. Gen. Physiol.* 42:793-802.
- Shinitzky, M. (1983). Membrane fluidity and receptor function. *Biomembranes* 12.
- Shinitzky, M. and Barenholz, Y. (1974). Dynamics of the hydrocarbon layer in liposomes of lecithin and sphingomyelin containing diacetylphosphate. *J. Biol. Chem.* 249:2652-2661.
- Shinitzky, M. and Barenholz, Y. (1978). Fluidity of cell membranes. *Int. Rev. Cytol.* 60:121-140.
- Shinitzky, M. and Henkart, P. (1979). Fluidity of cell membranes: current concepts and trends. *Int. Rev. Cyto.* 60:121-151.
- Shinnick-Gallagher, P. and Jacobs, R.S. (1976). An analysis of the sub-synaptic site of action of theophylline on isolated cat tenuissimus muscle. *J. Pharmacol. Exp. Ther.* 197:647-652.
- Singer, S.J. and Nicolson, G.L. (1972). The fluid mosaic model of the structure of cell membranes. *Science* 175:720-728.
- Slotboom, A.J.; DeHaas, G.H.; Bonsen, D.D.M.; Burbach-Westerhuis, G.J. and VanDeenen, L.L.M. (1970). Hydrolysis of phosphoglycerides by purified lipase preparations. *Chem. Phys. Lip.* 4:14-29.

- Spitzer, N. (1972). Minature endplate potentials of mammalian neuromuscular junction poisoned by botulinum toxin. *Nature* 237:26-27.
- Strichartz, G.R. (1973). The inhibition of sodium currents in myelinated nerve by quaternary derivatives of lidocaine. *J. Gen. Physiol.* 62:37-57.
- Stubos, C.; Kouyama, T. and Kinoshita, K. Jr. (1981). Effect of double bonds on the dynamic properties of the hydrocarbon region of lecithin bilayers. *Biochem.* 20:4257-4262.
- Takahashi, T.; Sugahara, T. and Ohgaka (1974). Purification of *Clostridium perfringens* PLC ( -toxin) by affinity chromatography on agarose-linked egg-yolk lipoprotein. *Biochem. Biophys. Acta* 351:155-171.
- Takeuchi, A. and Takeuchi, N. (1959). Active phase of frog end-plate potential. *J. Neurophysiol.* 22:395-441.
- Tanford, C. (1978). The hydrophobic effect on the organization of living matter. *Science* 200:1012-1015.
- Tasaki, I. and Takenaka, T. (1964). Effects of various potassium salts and proteases upon excitability on intracellularly perfused squid giant axon. *Proc. Natl. Acad. Sci. U.S.A.* 52:804-810.
- Tiedt, T.N.; Albuquerque, E.X.; Hudson, C.S. and Rash, J.E. (1978). Neostigmine-induced alterations at the mammalian neuromuscular junction. *J. Pharmacol. Exp. Ther.* 205:326-339.
- Tookey, H.L. and Balls, A.K. (1956). Plant phospholipase D. *J. Biol. Chem.* 218:213-239.
- Torda, T.A. and Gage, P.W. (1976). Effect of barbiturates on synaptic currents. *Anesth. Intens. Care* 4:199-202.
- Tucek, S. (1967). Subcellular distribution of acetyl-CoA synthetase, ATP citrate lyase, fumarate hydratase, and lactate dehydrogenase in mammalian brain tissue. *J. Neurochem.* 14:531-545.
- Van den Bosch, H. (1978). "Phospholipases", Phospholipids. Hawthorne Ansell.
- Vogel, W. (1974). Calcium and lanthanum effects at the modal membrane. *Pflügers Arch.* 350:25-39.

- Warnick, J.E. and Albuquerque, E. (1978). Changes in genotype expression, development and the effects of chronic penicillamine treatment on electrical properties at the posterior latissimus dorsi muscle in two lines at normal and dystrophic chickens. *Exp. Neurol.* 63: 135-162.
- Watson, J.E.; Gordon, T.; Jones, R. and Smith, M. (1976). The effect of muscle extracts on the contracture response of skeletal muscle to acetylcholine. *Pflugers Arch. Pharmacol.* 363:161-166.
- Waxman, S.G. and Foster, R.E. (1980). Ionic channel distribution and heterogeneity of the axon membrane in myelinated fibers. *Brain Res. Rev.* 2:205-234.
- Wells, M.A. and Hanahan, D.J. (1969). Studies on phospholipase A1, isolation and characterization of two enzymes from Crotalus adamanteus venom. *Biochem.* 8: 414-424.
- Wernig, A. (1975). Estimates of statistical release parameters from crayfish and frog neuromuscular junctions. *J. Physiol.* 244:207-221.
- White, D.A.; Pounder, O.J. and Hawthorne, J.N. (1971). Phospholipase A1 activity of guinea pig pancreas. *Biochim. Biophys. Acta* 242:99-107.
- Whittaker, V.P.; Dowdall, M.J. and Dowe, G.H.C. (1974). Proteins at cholinergic synaptic vesicles from the electric organ of torpedo. *Brain Res.* 75:115-131.
- Wilson, I.B. and Harrison, M.A. (1961). Turnover number of acetylcholinesterase. *J. Biol. Chem.* 236:2292-2295.
- Witkop, B. and Brossi, A. (1984). Natural toxins and drug development. *Alfreda Benzon Symposium 20 Copenhagen.*
- Yamamura, H.I. and Snyder, S.H. (1973). Affinity transport of choline into synaptosomes of rat brain. *J. Neurochem.* 21:1355-1374.
- Yang, S.; Freer, F. and Benson, S. (1967). Transphosphatidylation by phospholipase D. *J. Biol. Chem.*, 242:477-484.
- Yorio, T. and Bentley, P.J. (1976). Stimulation of active Na<sup>+</sup> transport by phospholipase C. *Nature* 261:722-724.
- Zaimis, E. (1954). Transmission and block at the motor endplate and in autonomic ganglia. *Pharmacol. Rev.* 6:53-57.

Zwaal, R.F.A.; Roelofsen, B.; Comfurius, P. and Van Deenen, L.L.M. (1971). Complete purification and some properties of phospholipase C from Bacillus cereus. Biochim. Biophys. Acta 233:474-479.

APPENDIX I

## APPENDIX I

## Components of the recording system:

A & B: amplified analogue inputs

A-D: A to D converter by Tecmar (Labtender)

BA: bath application of Ach

C: trigger pulse.

CE: common electrode

DA: data acquisition program

DB: zenner diode box

DN: data analysis program

DP: data plotting program

DS: data storage program

ET: electronic thermometer VSI (73A)

FM: FM tape recorder VETTER (Mod. D)



GB: gas bubbler

HP: heating perfusion HAAKE (FSe)

IE: current recording electrode

IBM: IMB XT PC

IS: internal suction for CAP electrode

IU: isolation unit Grass (SIU5)

KB: keyboard (IBM)

M: monitor (IBM)

N<sub>2</sub>: nitrogen gas tank

O<sub>1</sub>: oscilloscope & amplifier Tektronix (5103N)

O<sub>2</sub>: oscilloscope Tektronix (3A3)

PE: pressure ejection electrode

PIU: pressure isolation unit

PR: digital printer IBM

PRS: perfusion regulating system

S<sub>1</sub> & S<sub>2</sub>: stimulators Grass (S-88)

SE: stimulating electrode in oil chamber

SER: suction recording electrode

VR: voltage recording electrode

WPI: preamplifier unit WPI with S-7050A, S7071A,  
S7100A

APPENDIX II

## APPENDIX II

Programs written in BASICA:

TIMEGRPH: plots collected data, i.e., EPPs amplitudes versus the time duration of the experiment.

TIMERMP: plots the RMP amplitude versus the time duration of the experiment.

BAKUPDATA.1: back-ups data (both EPP & RMP) from the hard disc to the soft disc.

EPX: collects on-line EPP and RMP data.

AMPEVOK: calculates the quantal content from the failure and variance method experiments.

WAVERAGE.2: averages individual waveforms and calculates the 50% rise-time and the 50 & 75% decay-times.

Programs written in "C":

AVGFRQPLT: This program plots the mEPP frequency versus time.

AVGAMPPLT: plots the mEPP amplitude versus time.

AVGRMPPLT: plots the RMP versus time.

CLGSP: clears the plots saved on the disc.

PRGSP: prints all of the graphic screens saved on the disc.

DEXPD: transfers the data from the hard to the soft discs.

GETMEPP: collects the mEPP data.

Programs written in APL:

WORK2: is a general directory for storing "working" data, i.e., collecting programs. They do not have names, but rather are addressed by pressing the F keys from the keyboard. They are:

- F<sub>1</sub>: Retrieve a specified waveform from the hard disc.
- F<sub>2</sub>: Clean the graphics from the screen.
- F<sub>3</sub>: Switch the operation to the text for a choice of the next function.
- F<sub>4</sub>: Switch the computer operation to the graphics mode.
- F<sub>5</sub>: Switch the computer to the data collecting mode.
- F<sub>6</sub>: Save a specific waveform on the hard disc.
- F<sub>7</sub>: Plot the data on the monitor screen.
- F<sub>8</sub>: Plot the axis of the graph on the monitor screen.
- F<sub>9</sub>: Plot the data via the dot matrix printer.
- F<sub>10</sub>: Set the parameters for data acquisition, i.e., sensitivity, time gain, etc.

More programs written in APL. These programs are addressed by pressing Ctr and an F key:

F<sub>1</sub>: erases the saved waveforms.

F<sub>2</sub>: allows for a change in the plot title.

F<sub>3</sub>: averages the waveforms as designated by the experimenter.

F<sub>4</sub>: resets the averager to 0.

F<sub>5</sub>: reads the maximums of the saved waveforms.

F<sub>6</sub>: plots waveform amplitudes over-time.

F<sub>7</sub>: plots the averaged data.

F<sub>8</sub>: backs-up onto a soft disc and retrieves data points from that disc.

F<sub>9</sub>: automatically saves waveforms onto the hard disc.

TTEST: is a directory which contains programs designed for statistical analysis. These programs are addressed by pressing F keys and Ctr from the keyboard.

F<sub>1</sub>: analyzes two groups of data from the hard disc as defined by the experimenter.

F<sub>2</sub>: calculates t-test values, i.e., SD, SE, t, p, etc. for the data entered from the keyboard.

F<sub>3</sub>: estimates the sample size needed to achieve the desired significance, when given the variance.

F<sub>4</sub>: allows for the entry of data from the keyboard.

Some commands needed for editing data and changing from the acquisition mode to the calculation mode:

Ctr & T: allows one to set-up tabs for the data intended for elimination.

Ctr & D: eliminates the specified data.

Ctr & E: shifts the mode of operation from data acquisition to calculation.



APPENDIX III

### Appendix III

This appendix contains the names of the enzymes, used in the text of this dissertation, and the number assigned to them by the INB Enzyme Commission.

Acetylcholinesterase: (AChE) (E.C. 3.1.1.7)

Phospholipase A<sub>1</sub>: (PLA1) (E.C. 3.1.1.32)

Phospholipase A<sub>2</sub>: (PLA2) (E.C. 3.1.1.4)

Phospholipase C: (PLC) (E.C. 3.1.1.5)

Phospholipase D: (PLD) (E.C. 3.1.4.39)

APPENDIX IV

#### Appendix IV

Drugs and enzymes used in the present work:

Acetylcholine chloride (ACh)

Carbamylocholine (Carb)

Phospholipase C (PLC) type XII

Tetrodotoxin (TTX)

d-Tubocurarine chloride (dTc)

All of the drugs were purchased from the Sigma company.

APPROVAL SHEET

The dissertation submitted by Lukasz M. Konopka-Egan has been read and approved by the following committee:

Dr. Alexander G. Karczmar, Director  
Professor of Pharmacology, Loyola University

Dr. Michael Collins  
Professor of Biochemistry, Loyola University

Dr. Nae Dun  
Associate Professor of Pharmacology, Loyola University

Dr. Alexander Friedman  
Professor of Pharmacology, Loyola University

Dr. Jay Z. Yeh  
Professor of Pharmacology, Northwestern University

The final copies have been examined by the director of the dissertation and the signature which appears below verifies the fact that any necessary changes have been incorporated and that the dissertation is now given final approval by the Committee with reference to content and form.

The dissertation is, therefore, accepted in partial fulfillment of the requirements for the degree of Doctor of Philosophy.

12/2/85  
Date

  
Director's Signature