

MAR 26 1997

TEXAS STATE
DOCUMENTS

Integrated Brush Management Systems (IBMS): Strategies and Economics

C. Wayne Hanselka, Wayne T. Hamilton and J. Richard Conner*

An Integrated Brush Management System (IBMS) is a strategic plan for long-range, integrated brush and weed management. An IBMS begins with the setting of management objectives based on an inventory of range resources, the identification of problems, and the economic analysis of alternative solutions. Those management objectives must consider all enterprises affected by brush management, such as wildlife and livestock management.

IBMS involve long-term planning (10 to 20 years) so that the biological processes influenced

by treatments can be fully assessed as they affect production.

The steps in establishing an IBMS are:

1. identifying problems;
2. setting objectives;
3. conducting a resource inventory;
4. considering alternative management strategies;
5. analyzing the economics of treatment alternatives; and
6. using feedback and experience to improve the system.

These steps are explained fully in L-5146, "Integrated Brush Management Systems (IBMS) for Texas," available from the Texas Agricultural Extension Service. Steps 4 and 5 will be addressed in this publi-

cation. The selection of the appropriate brush management technologies should follow examples given, and should be made with the use of the EXSEL brush management decision-aid software. This software also projects the responses of target brush and weeds and associated vegetation over the planning period.

Decision-making Charts for Target Species

After the characteristics of the brush problem (species, density, canopy cover) have been determined as part of the IBMS inventory process, the most technically feasible brush management alternatives can be developed to meet specific goals. Some of these decisions may require specialized expertise; however, many of the basic

*Associate Department Head and Extension Program Leader for Rangeland Ecology and Management; Director, Center for Grazingland and Ranch Management; and Professor of Rangeland Ecology and Management and Agricultural Economics; Texas A&M University System.

decisions can and should be made by ranch personnel who are most familiar with the situation.

Several decision-aid flow charts have been developed as examples of the IBMS planning process. The primary elements of these flow charts are the nature of the problem, applicable technologies for initial (primary) and follow-up (secondary) treatments, and contingency considerations. Such information is most easily developed when the brush problem is a single species stand, and when a background of research information and management experience is available. However, acceptable treatments for multiple species in the same stand can be identified by determining the best technologies for individual species and selecting those that are most generally applicable.

Mesquite

The flow chart for mesquite or twisted acacia (Fig. 1) is an example of an appropriate question/answer sequence for decision making. The chart shows the nature of the problem (the density, growth form, size and distribution of the target species), which is critical to identifying technically feasible treatment alternatives. The first decision point establishes whether reseeding is necessary. If not, the flow chart proceeds to an evaluation of methods that selectively control honey mesquite and twisted acacia. The next decision asks for an evaluation of the pricklypear problem. If pricklypear is also a problem, certain methods (such as chaining, roller chopping or rootplowing) that may control mesquite but worsen the pricklypear problem are eliminated,

or sequenced after an initial pricklypear control treatment. This logic also may be applied in reverse. If the management goal is to reduce the mesquite problem and increase the availability of pricklypear (for wildlife habitat or emergency livestock feed), then a negative answer at the pricklypear decision point leads to appropriate technologies for consideration. The flow chart was developed for south Texas; pricklypear may not be as influential in developing a system for north Texas. It is important to use tailor-made flow charts for different areas and conditions.

Making use of feedback keeps the planning process flexible and dynamic. As brush is managed over time, the nature of the brush problem changes, which in turn dictates changes in the control methods used. For example, if the answer to the "burning viable option?" question is no, a loop feeds back into the flow chart so that new problem characteristics and the entire array of applicable alternative treatments can be reconsidered.

Huisache

A similar decision-aid flow chart for huisache is presented in Figure 2. Notice that the influence of soils is a primary consideration in developing huisache management systems. For example, rootplowing and individual plant grubbing are discouraged on clay sites because they leave the soil surface extremely rough and present management problems for many years following treatment. Also, the efficacy of soil-applied herbicides decreases as soil clay content increases.

Macartney Rose

Macartney rose may grow as scattered plants or isolated clumps that can be treated individually, or in dense stands that require broadcast treatment (Fig. 3). Alternatives have been developed by research and producer experience for treating each kind of Macartney rose stand. Treatments must be carefully selected because primary methods vary in initial effectiveness and cost, and each requires a different method and timing of secondary treatment.

Alternatives for treating small areas with light-to-moderate cover of Macartney rose regrowth are prescribed burning, or herbicide applications followed by prescribed burning. Therefore, the option for prescribed burning immediately follows the description for light-to-moderate brush stands. This requires managers to consider all aspects of prescribed burn as they may apply to their specific operation and management goals (for example, expected response of wildlife may be considered a positive attribute).

Once the basic flow charts are developed for target plant species, appropriate decision points for each of the alternative technologies become obvious. Feedback mechanisms keep the planning flexible through the time period selected for evaluating the practices. For example, if the original undisturbed stand of Macartney rose has been reduced by mechanical methods, and prescribed burning is not a viable option, the flow chart feeds back to the original problem characteristics. The same feedback loop works in case a prescribed burn is missed, and provides a working continuum for management planning.

MESQUITE OR TWISTED ACACIA > 50% OF BRUSH COVER

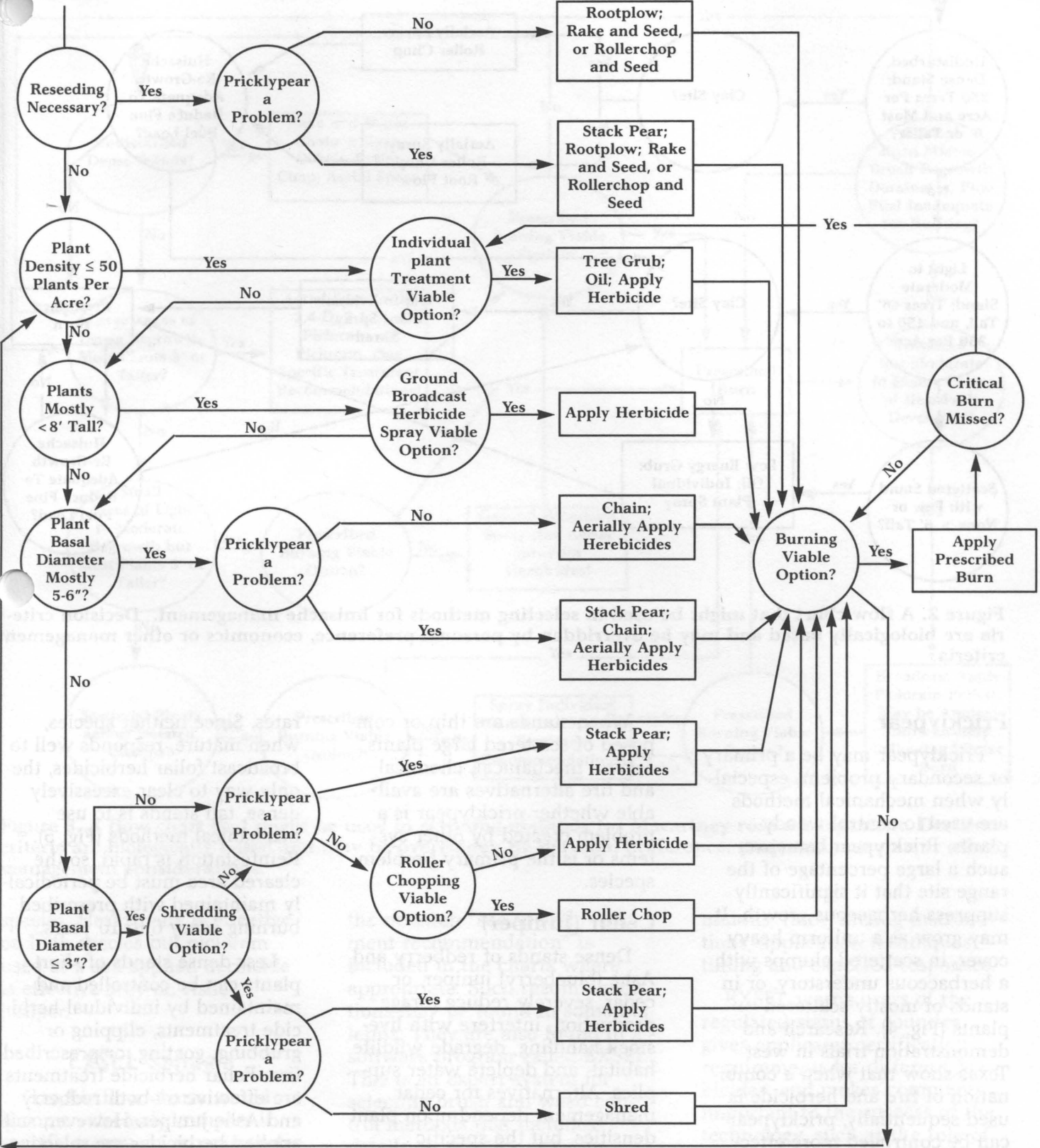

Figure 1. A flow chart that might be used in selecting methods for mesquite and twisted acacia management in South Texas. Decision criteria are biologically based and may be overridden by personal preference, economics or other management criteria.

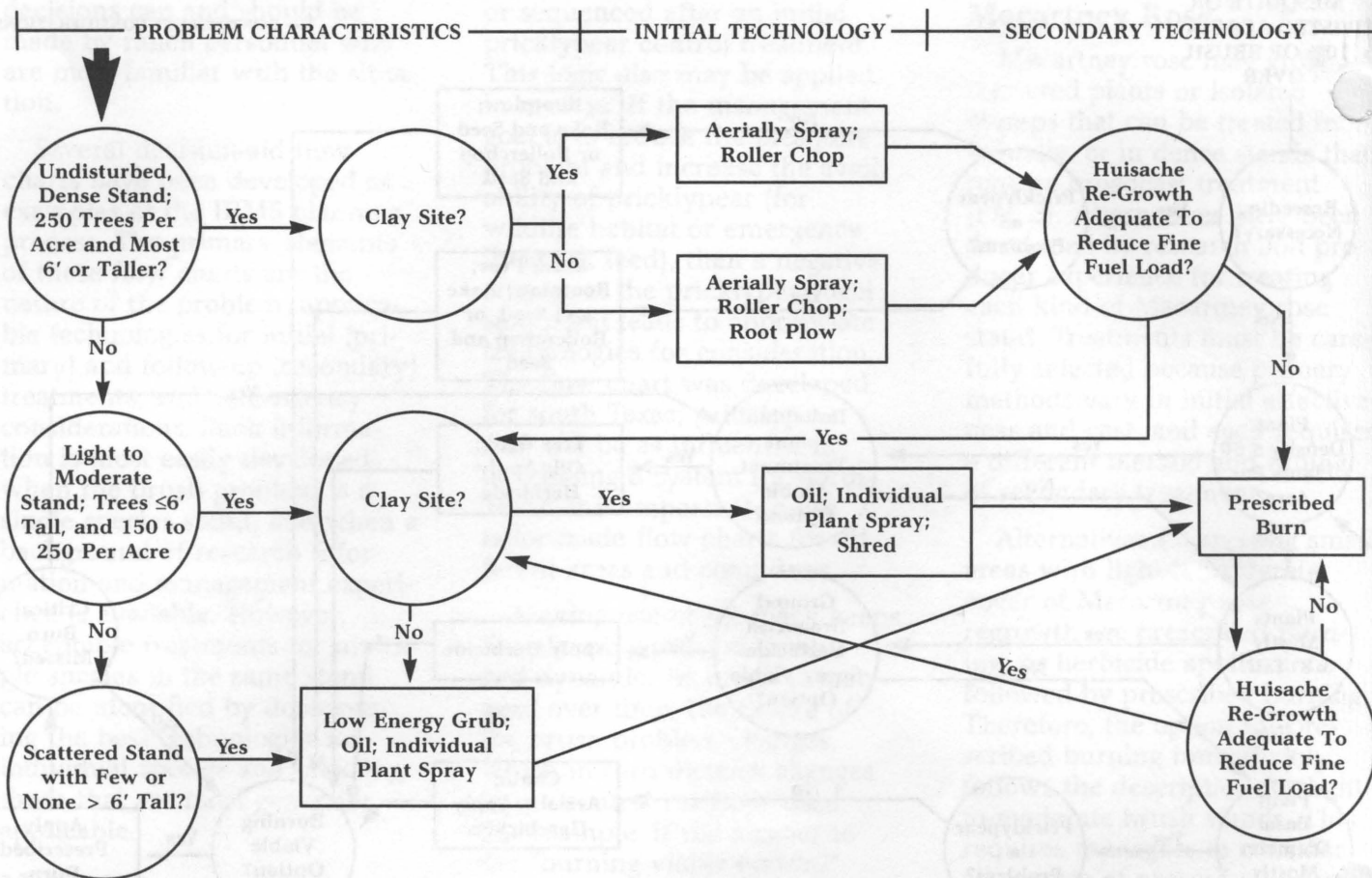

Figure 2. A flow chart that might be used in selecting methods for huisache management. Decision criteria are biologically based and may be overridden by personal preference, economics or other management criteria.

Pricklypear

Pricklypear may be a primary or secondary problem, especially when mechanical methods are used to control woody plants. Pricklypear can cover such a large percentage of the range site that it significantly suppress herbaceous growth. It may grow as a uniform heavy cover, in scattered clumps with a herbaceous understory, or in stands of mostly scattered plants (Fig. 4). Research and demonstration trials in west Texas show that when a combination of fire and herbicide is used sequentially, pricklypear can be controlled more effectively and with less herbicide.

When stands are thin or composed of scattered large plants, several mechanical, chemical and fire alternatives are available whether pricklypear is a problem created by other systems or is the primary problem species.

Cedar (Juniper)

Dense stands of redberry and Ashe (blueberry) juniper, or cedar, severely reduce forage production, interfere with livestock handling, degrade wildlife habitat, and deplete water supplies. Alternatives for cedar management depend upon plant densities, but the specific species involved affects efficacy

rates. Since neither species, when mature, responds well to broadcast foliar herbicides, the only way to clear excessively dense, tall stands is to use mechanical methods (Fig. 5). Reinfestation is rapid, so the cleared area must be periodically maintained with prescribed burning every 6 to 10 years.

Less dense stands of short plants can be controlled and maintained by individual herbicide treatments, clipping or grubbing, goating, or prescribed fire. Foliar herbicide treatments are effective on both redberry and Ashe juniper. However, soil-applied herbicides are selective depending upon the cedar

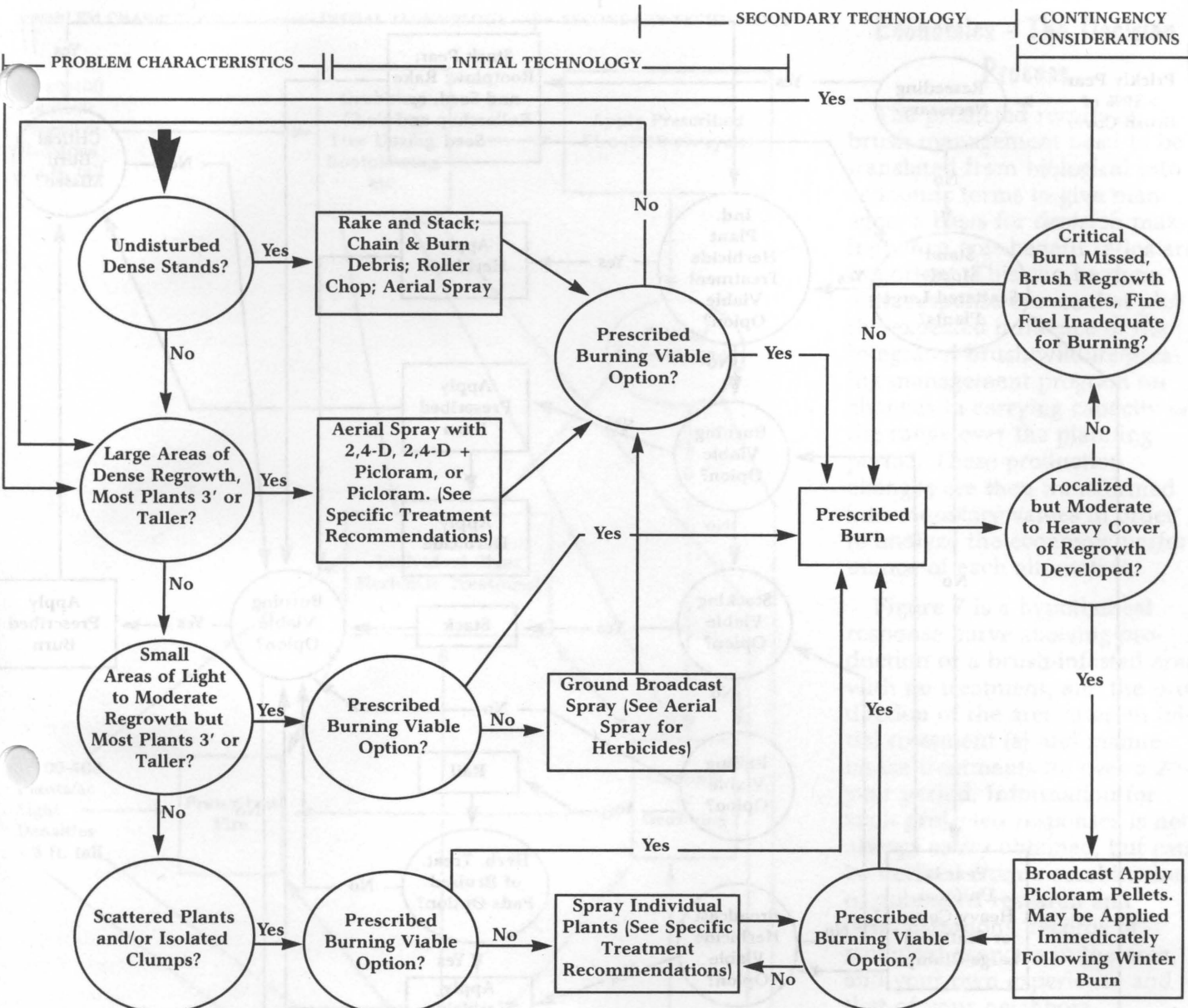

Figure 3. A flow chart that might be used in selecting methods for Macartney rose management. Decision criteria are biologically based and may be overridden by personal preference, projected outcome or other management considerations.

species. Hexazinone is effective on both species but picloram used as a soil-applied herbicide is effective only on Ashe juniper.

EXSEL Software

Graphic flow charts would become extremely complex if specific treatment recommendations were included; therefore,

the notation "see specific treatment recommendation" is included in the charts where appropriate. Such recommendations may be found in some bulletins. They are also found in a software program called EXSEL. This is an expert system for selecting brush and weed control methods that includes details on practice selection, specific herbicides and combi-

nations, rates, mixing instructions, application techniques, timing and expected responses.

EXSEL warns users of the regulated status of counties, gives applicator certification requirements for different herbicides, and makes comments important to the success of the technology, such as the role of soil moisture, the need for

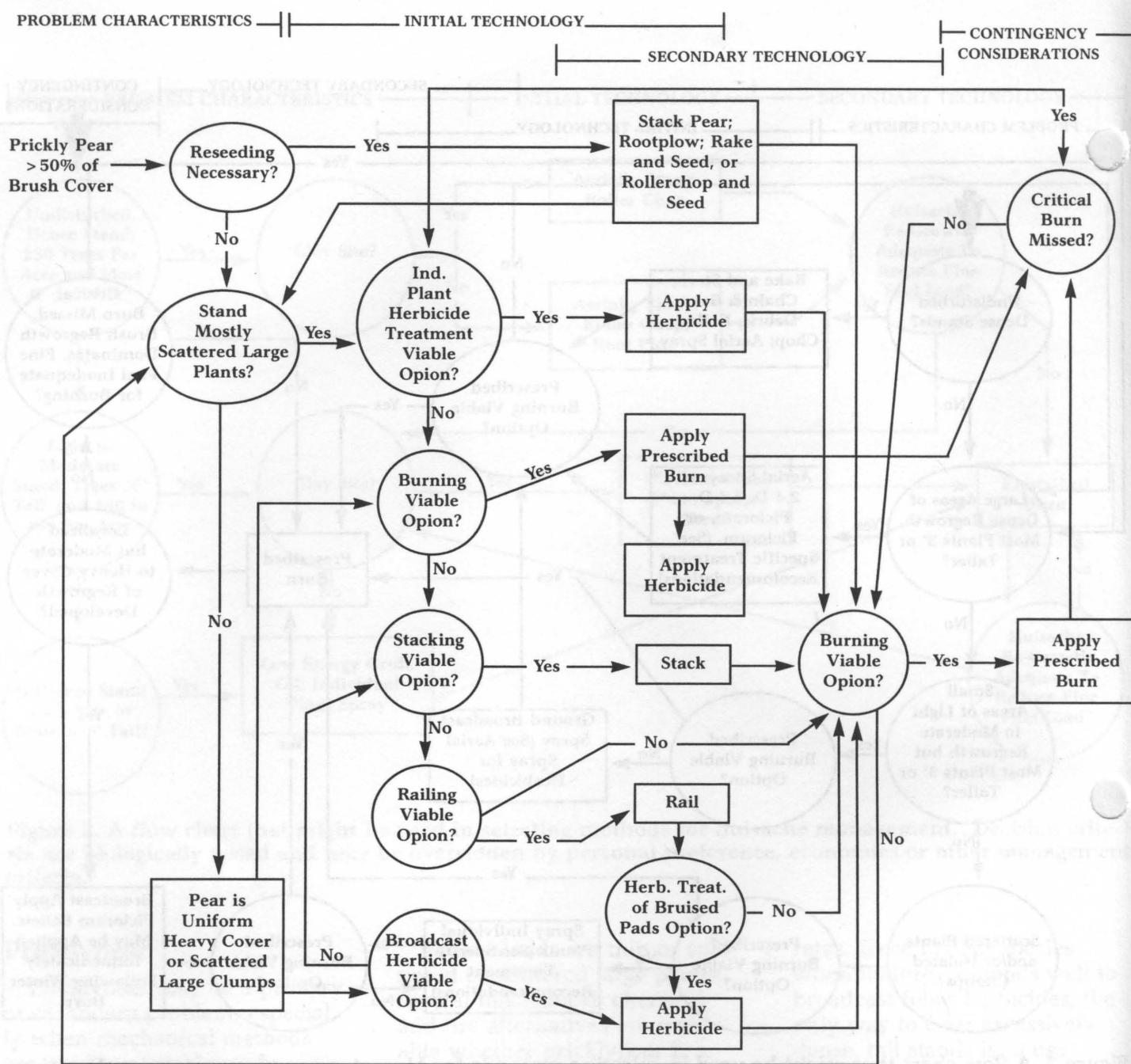

Figure 4. A flow chart that might be used in selecting methods for pricklypear management.

reseeding, etc. The software considers factors such as the nature of the brush problem; soil texture and depth; plant density, height and stem diameter; soil moisture; topography; viability of aerial application; need for reseeding; and acceptable level of treatment efficacy (target plant mortality) in matching the problem with appropriate technology (Fig. 6).

EXSEL is updated as needed to include technology changes and additions.

This decision-aid software prompts the user to provide information on the essential factors that must be considered when making brush and weed management decisions. Once the required information is entered, EXSEL can identify the most technically feasible

mechanical or chemical technology for overcoming the problem, and determine whether prescribed fire is a feasible alternative. EXSEL reports the expected responses of vegetation to various treatments. For example, the software shows when the maximum production increase should occur after treatment, how long this level of production will last, and wh

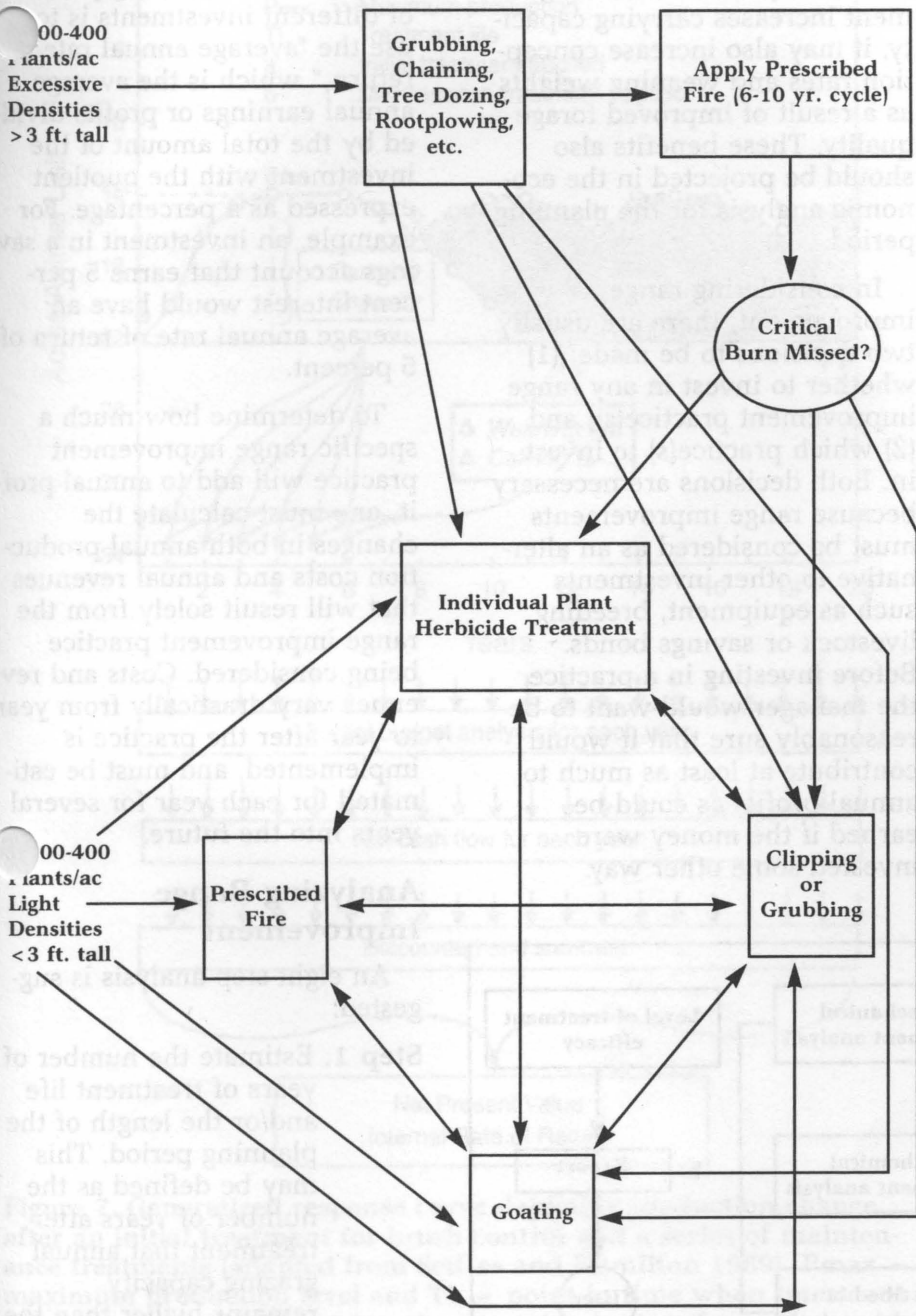

Figure 5. Decision-making options for managing cedar.

production will return to pre-treatment levels. This helps users compare the economics of alternative treatments.

EXSEL can be purchased from the Texas Agricultural Extension Service. Contact your

county Extension agent or the Range Specialists' office at (409) 845-2755. Using the flow charts in this bulletin together with the EXSEL software is the best way to select the most appropriate brush or weed control technology.

Economics - The Decision Process

The predicted results of brush management need to be translated from biological into economic terms to give managers a basis for decision making when cost-benefit ratios are important. This can be done with response curves that plot the expected influence of the integrated brush/wildlife/grazing management program on changes in carrying capacity of the range over the planning period. These production changes are then transformed into monetary values in order to analyze the economic performance of each alternative.

Figure 7 is a hypothetical response curve showing production of a brush-infested area with no treatment, and the production of the area after an initial treatment (a) and maintenance treatments (b) over a 20-year period. Information for such projected responses is not always easily obtained, but can be derived from a combination of published research and demonstrations, records of technical agencies in the area, and your own experience and that of your neighbors.

The shaded area of the curve is important. Benefits from the initial treatment reached the highest level in years 3 through 6, but declined thereafter to year 12. Maintenance treatments can stretch the benefits far beyond the original planning period, and are essential if an IBMS is to show financial success.

Managers should consider that not controlling brush at all could result in lower carrying capacity, poorer animal performance, and higher variable

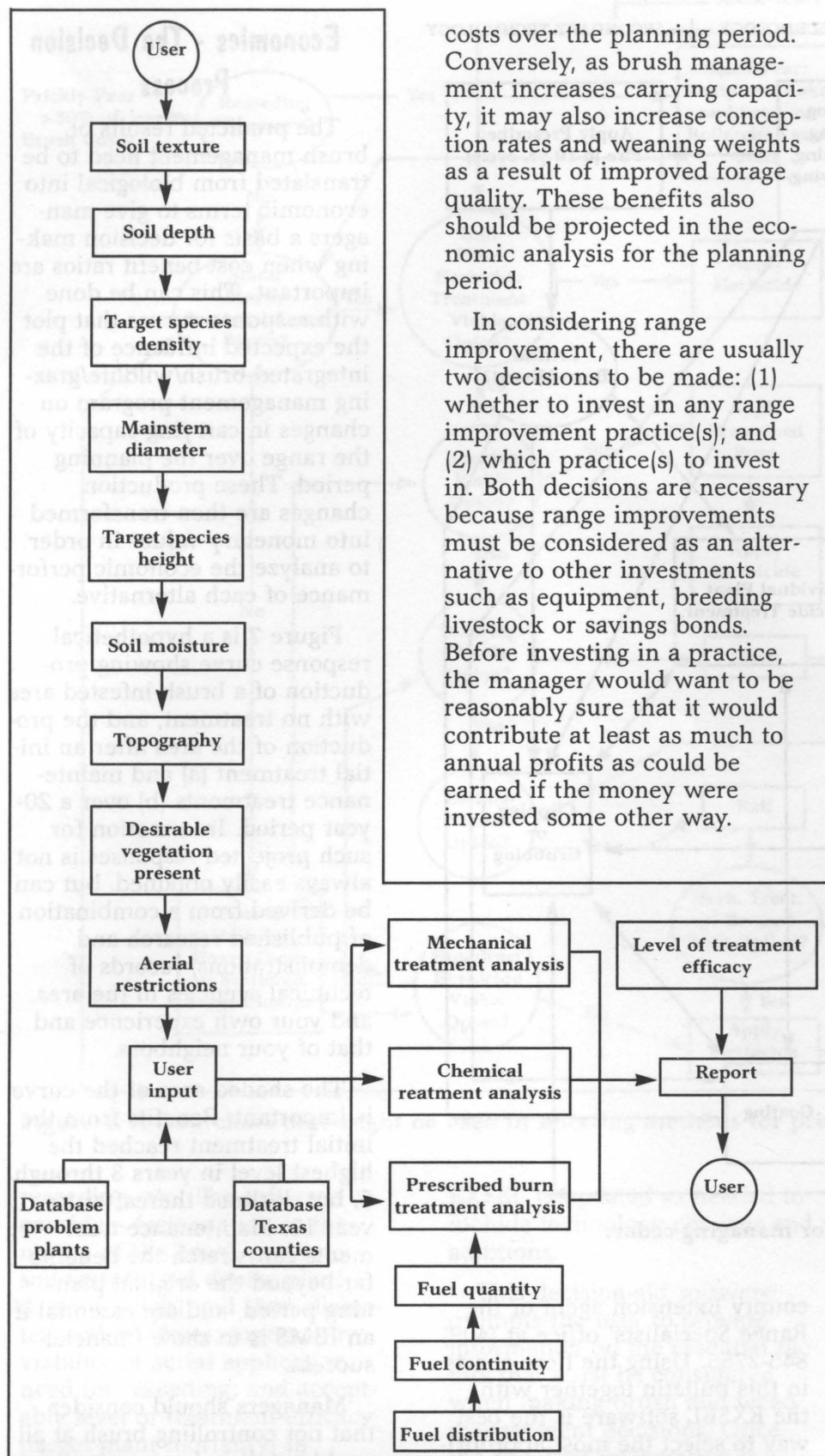

Figure 6. User input and output components of EXSEL, an expert system for brush and weed control technology selection (from Hamilton et al. 1993).

costs over the planning period. Conversely, as brush management increases carrying capacity, it may also increase conception rates and weaning weights as a result of improved forage quality. These benefits also should be projected in the economic analysis for the planning period.

In considering range improvement, there are usually two decisions to be made: (1) whether to invest in any range improvement practice(s); and (2) which practice(s) to invest in. Both decisions are necessary because range improvements must be considered as an alternative to other investments such as equipment, breeding livestock or savings bonds. Before investing in a practice, the manager would want to be reasonably sure that it would contribute at least as much to annual profits as could be earned if the money were invested some other way.

One way to compare the annual income earning potential of different investments is to use the "average annual rate of return," which is the average annual earnings or profits divided by the total amount of the investment with the quotient expressed as a percentage. For example, an investment in a savings account that earns 5 percent interest would have an average annual rate of return of 5 percent.

To determine how much a specific range improvement practice will add to annual profit, one must calculate the changes in both annual production costs and annual revenues that will result solely from the range improvement practice being considered. Costs and revenues vary drastically from year to year after the practice is implemented, and must be estimated for each year for several years into the future.

Analyzing Range Improvement

An eight-step analysis is suggested:

Step 1. Estimate the number of years of treatment life and/or the length of the planning period. This may be defined as the number of years after treatment that annual grazing capacity remains higher than the original grazing capacity. In practice this is usually 8 to 15 years.

Step 2. Estimate annual production levels and receipts from saleable products for the original and subsequent years in the planning period. The number of cows (from the response curve),

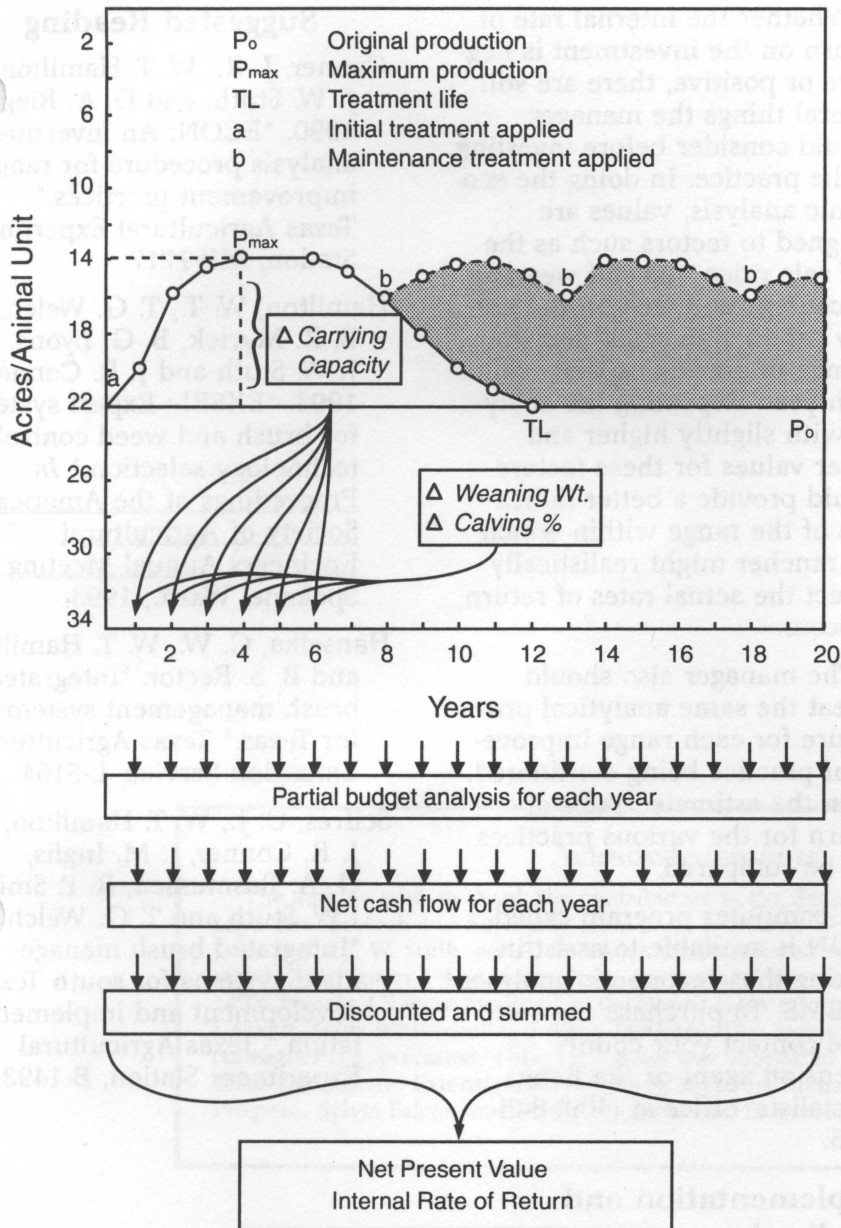

Figure 7. Generalized response curve depicting production change after an initial treatment for brush control and a series of maintenance treatments (adapted from Scifres and Hamilton 1989). P_{max} = maximum production level and TL = point in time when treatment effect is exhausted. These functions provide basic information needed for economic analysis of range improvement practices in general, including prescribed burning.

total annual production (number x weaning percentage x the average sale weight per calf for each year in the planning period), and annual receipts are estimated as annual production multiplied by the average annual sale price per pound of calf.

Step 3. Estimate the change in annual revenues due to the range improvement practice by subtracting the sales receipts in the original year from the sales receipts for each subsequent year in the planning period.

Step 4. Estimate the cost of implementing the practice and the year in which costs will be incurred.

Step 5. Estimate the changes in annual production costs due to the range improvement program and the year in which they will be incurred. These include annual costs per herd, changes in costs due to more livestock being stocked, and changes in per head costs due to the program. Then subtract original year production costs from subsequent year costs.

Step 6. Determine the net cash flow for each year by subtracting total practice implementation costs and changes in production costs from the change in sales receipts.

Step 7. Discount the net cash flow for each year to account for the differences throughout the planning period and the rate of return on the money that could be obtained if it were used in an alternative investment. Then sum the discounted net cash flows.

Step 8. If the sum of the discounted net cash flow is zero or positive, then the range improvement practice is estimated to be economically feasible. If the sum is zero, then the investment in the range improvement practice is estimated to earn exactly the same average annual rate of return as the alternative investment. If the sum is greater than zero, then the range improvement practice is estimated to produce an average annual rate of return that is greater than the alternative. If the sum is negative, the range improvement practice is estimated to produce an average annual rate of return that is less than the specified rate of the alternative. The internal rate of return of the investment is the alternative annual rate of return which results in the sum of the discounted net cash flows equaling exactly zero.

Whether the internal rate of return on the investment is negative or positive, there are still several things the manager should consider before investing in the practice. In doing the economic analysis, values are assigned to factors such as the calf sale price, the calf weaning percentage and weight, the per cow production costs, and the change in grazing capacity for each year. Repeating the analysis with slightly higher and lower values for these factors would provide a better indication of the range within which the rancher might realistically expect the actual rates of return to occur.

The manager also should repeat the same analytical procedure for each range improvement practice being considered. Then the estimated rates of return for the various practices can be compared.

A computer program called ECON is available to assist in making these economic analyses of IBMS. To purchase the software contact your county Extension agent or the Range Specialists' office at (409) 845-2755.

Implementation and Feedback

When a brush management system is implemented, information from actual results obtained should be used to improve the future accuracy of the planning process. In this way, IBMS becomes a planning continuum that provides for increasingly better decision making.

Suggested Reading

- Conner, J. R., W. T. Hamilton, J. W. Stuth, and D. A. Rieg. 1990. "ECON: An investment analysis procedure for range improvement practices." Texas Agricultural Experiment Station, MP-1717
- Hamilton, W. T., T. G. Welch, B. R. Myrick, B. G. Lyons, J. W. Stuth and J. R. Conner. 1993. "EXSEL: Expert system for brush and weed control technology selection." *In Proceedings of the American Society of Agricultural Engineers Annual Meeting.* Spokane, Wash., 1993.
- Hanselka, C. W., W. T. Hamilton and B. S. Rector. "Integrated brush management systems for Texas." Texas Agricultural Extension Service, L-5164
- Scifres, C. J., W. T. Hamilton, J. R. Conner, J. M. Inglis, G. A. Rasmussen, R. P. Smith, J. W. Stuth and T. G. Welch. "Integrated brush management systems for south Texas: development and implementation." Texas Agricultural Experiment Station, B-1493.

Acknowledgments

The authors wish to thank the contributors to the development of the IBMS concept. The research and Extension team of C. J. Scifres, W. T. Hamilton, J. R. Conner, J. M. Inglis, J. W. Stuth, and T. G. Welch developed and refined the concept since the mid-1970s. Figures 1-4 are from Texas Agricultural Experiment Station publication B-1493. Figures 4-5 were modified or developed from information provided by Darrell Ueckert, Steve Whisenant and Allan McGinty. The cooperation of these authors and colleagues is appreciated. This publication was supported by a grant from the 1996 Texas Agricultural Extension Service Integrated Pest Management mini-grants Program. Sylvia Falcón and Corby Craig assisted in developing the manuscript.

Step 7. Discount the net cash flow for each year to account for the difference throughout the planning period and the rate of return on the money that could be obtained if it were used in an alternative investment. Then sum the discounted net cash flows.

Step 8. If the sum of the discounted net cash flows is positive, then the range improvement practice is estimated to be economically feasible. If the sum is zero, then the investment in the range improvement practice is estimated to earn exactly the same average annual rate of return as the alternative investment. If the sum is greater than zero,

Whether the internal rate of return on the investment is negative or positive, there are still several things the manager should consider before investing in the practice. In doing the economic analysis, values are assigned to factors such as the calf sale price, the calf weaning percentage and weight, the cow production cost, and the change in grazing capacity for each year. Repeating the analysis with slightly higher and lower values for these factors would provide a better estimation of the range within which the rancher might realistically expect the actual rates of return to occur.

The manager who should repeat the same analytical procedure for each range improvement practice being considered.

Suggested Reading

Conner, J. R., W. T. Hamilton, J. W. Smith and D. A. Slaughter. 1986. "ECON: An investment analysis procedure for range improvement practices." Texas Agricultural Experiment Station, MP-1717.

Hamilton, W. T., T. G. Welch, B. R. Myrick, B. G. Lyons, J. W. Smith and J. R. Conner. 1993. "EXSEL: Expert system for brush and weed control technology selection." In Proceedings of the American Society of Agricultural Engineers Annual Meeting, Spokane, Wash., 1993.

Hanselka, L. W., W. T. Hamilton and J. R. Conner. "Integrated brush management systems for Texas." Texas Agricultural Extension Service, L-5164.

return for the various practices can be estimated. The manager who should repeat the same analytical procedure for each range improvement practice being considered.

Implications and Conclusions

When a brush management system is implemented, a manager should be able to estimate the return on investment. This return can be used to improve the accuracy of the planning process. In this way, EXSEL becomes a planning continuum that provides for increasingly better decision making.

Educational programs of the Texas Agricultural Extension Service are open to all people without regard to race, color, sex, disability, religion, age or national origin.