



ASIA TURBOMACHINERY & PUMP SYMPOSIUM
SINGAPORE | 22 - 25 FEBRUARY 2016
M A R I N A B A Y S A N D S



REGIONAL MACHINERY BEST PRACTICES

BY WILLIAM E FORSTHOFFER
MICHAEL SEAN FORSTHOFFER

FORSTHOFFER ASSOCIATES, INC.

**The Crossings
1098 Washington Crossing Road – Suite 4
Washington Crossing, Pennsylvania 18977**

**(215) 321-1907
(215) 321-1908
FAX (215) 321-1909**

**ATPS 2016 TUTORIAL
REGIONAL MACHINERY BEST PRACTICES
BY WILLIAM E FORSTHOFFER
MICHAEL SEAN FORSTHOFFER**

This presentation will cover the following major topic FAI Best Practices to allow the attendee to assure that new and existing Machinery and their Systems are of the highest safety and reliability:

- Pre- Bid Meetings for Critical Machinery Selection
- Effective FAT (Factory Acceptance Testing) Methods
- Pump Best Practices
- Compressor Best Practices
- Auxiliary System Best Practices
- Plant Predictive & Proactive Maintenance Best Practices

Over the last 26 years we have been frustrated by the low implementation rate of recommendations made to management by site machinery specialists world-wide (less than 50%). This fact is responsible for publication our Machinery Best Practice Handbooks. These Handbooks contains over 350 Machinery Best Practices (Not contained in Industry – API etc. Specifications) beginning with Project Best Practices, focusing on specific Machinery Type (Pumps, Compressors etc.) and Seal Best Practices and concluding with Commissioning, Preventive and Predictive Best Practices.

- Each Best Practice and Lesson Learned, responsible for the Best Practice, is presented in clear and concise terms.
- Each Best Practice has benchmarks to prove that results have optimized safety, reliability and profits.
- Supporting information for each Best Practice is presented to ensure timely management implementation of recommendations.

Based on our experience in the region (Since 1988), we have selected key best practices that will significantly increase your plant's machinery safety and reliability and assure management implementation.

**ATPS 2016 TUTORIAL
REGIONAL MACHINERY BEST PRACTICES
INDEX**

<u>Tab</u>	<u>Description</u>
1	BP 1.1 Early Input Of Lessons Learned
2	BP 1.6 ITB Preparation Guidelines
3	BP 2.7 Operate In The EROE (Equipment Reliability Operating Envelope)
4	BP 3.9 Screen For Centrifugal Compressor Impeller Design During The Pre – Bid Meeting
5	BP 7.11 Always Test Oil System Relief Valves On The Oil Console and Not On PSV Test Rig
6	BP 7.14 Install Dual SS Accumulators In Critical Service Lube Oil Systems
7	BP 9.1 End User's Must Be Proactive In The Project Phase For Optimum Reliability
8	BP 11.7 Trend all rotating equipment performance (Head, Flow & Efficiency)

B.P. 1.1 : Input Machinery Lessons Learned to the project team during the Project Pre- Feed Phase.

Obtain Plant, Company and Industry (From Seminar Attendance & Publications) Lessons Learned and incorporate these “Lessons Learned” into the Project Scope during the Pre Feed Phase to assure that the “Cost of Incorporation” will be included in the project scope.

Define the associated Best Practice for each lesson learned and note these BP’s on the appropriate Machinery Data Sheet on a special page to assure they are included in all quoting Suppliers Scope and Costs. This action will assure that all Supplier content will be equal.

Do not accept exceptions to any of the required Best Practices. If a certain Supplier refuses to incorporate any or all of the Best Practices, remove them from the Bidders List for this particular Project and explain why they were removed.

Confirm that all required Best Practices are included in the Suppliers Final Bids and the Purchase order to eliminate any Project Schedule Delays and Cost Adders.

L.L: Failure to incorporate “Lessons Learned” during the Pre –Feed Phase of the project will result in lower plant safety, reliability, and revenue and/or extended project schedule and can result in supplier cost adders.

Not having specific Lessons Learned defined as Best Practices in the Invitation to Bid has resulted in the following issues during the Project:

- Significant differences in Supplier Scope
- Significant difference in Supplier Costs resulting in frequent Low Cost Bid (And most usually lower Scope) Acceptance
- Possible required Supplier Scope Changes during the Project resulting in Schedule Delays and/or high Cost Adders

Note that Industry Specifications (API) and Company Specifications are not written for specific plant conditions and locations and will not include all the necessary Best Practices.

BENCHMARKS:

This Best Practice has been used by the writer since 1990 and has been incorporated into the following projects with the benefits noted above:

- MEGA Ethylene Plant
- MEGA Butyl Rubber Plant
- Methanol Plants
- Refinery Hydrocracker Recycle Compressor
- Oil and Gas Booster Compressor Trains
- Small (Modular) LNG Plants

This practice has resulted in minimum bid decision time for large compression trains (10 weeks from issue of ITB). Life Cycle cost savings exceed \$ 5,000,000.00 per year for the present process unit size.

SUPPORTING MATERIAL:

As someone who has been involved with projects as a rotating equipment vendor, end user and consultant since 1970, I have had the opportunity to see custom designed rotating equipment projects from all industry viewpoints. Regardless of your position, you will face the challenges of company profit optimization, depleted workforce experience levels and time constraints.

My initial involvement with rotating equipment projects began in 1970 as a project engineer for a centrifugal compressor vendor where I was responsible for project management of all process compressor applications. This interesting and busy portion of my career taught me many valuable lessons and the challenges and associated action required to survive this experience. 'Vendor lessons learned' are detailed in Figure 1.1.1.

- Time constraints forced the acceptance of what was on the data sheet
- The tendency was to think inside the flanges of the compressor only and not consider the process
- Questions to the end user/contractor were minimal based upon competitive pressures and time constraints
- Copying from past jobs 'cut and paste' was a necessity to minimize engineering hours and Today (21st Century) is electronic cut and paste
- Contractor/end user questions diminished valuable engineering time. There was little time or money for visits to client plants unless there were significant design problems

Figure 1.1.1 Vendor lessons learned

It was interesting to note that in my next industry position as a corporate rotating equipment specialist for a major oil, gas and chemical company, I observed that the characteristics noted above were present in all equipment companies regardless of global location or final product. However, in my new position there were also many challenges as noted in Figure 1.1.2.

- Time constraints forced acceptance of what was on the process data sheet without time to question the basis for the stated conditions
- The tendency initially was to think inside the machinery flanges, but eventually it was understood that all equipment is directly influenced by the process
- Contact with the client (plant where the equipment will be installed) was minimal based on project team pressures for schedule milestones
- Company specification contents were increasing rapidly since all company divisions and plants were required to review specifications and therefore naturally contribute something
- There was limited project budget for visits to client plants unless there were equipment design problems.

Figure 1.1.2 End user lessons learned

Review Figures 1.1.1 and 1.1.2 and observe the similarities all imposed by time and budget constraints. Also, observe how the involved individuals seldom have the opportunity to observe how their client operates and what their objectives are.

Since 1990, as a rotating equipment consultant engaged in troubleshooting, machinery selection and revamps and site specific operator, maintenance and engineering training, I have other challenges but the similarities are striking and the challenges are the same. These facts are noted in Figure 1.1.3.

- Both vendors and clients have limited experience bases
- Decisions are made quickly, often without benefit of all the pertinent facts
- Most projects are run on the basis of minimum capital investment and not life cycle cost
- Implementation of action plans is slow
- Vendor and end user's interface infrequently – usually only during field failures

Figure 1.1.3 Contractor/consultant lessons learned

Based on my experience, I have learned, most of the time the hard way, that all three of these groups (vendors, contractors and end users) have the same objective but different means of obtaining that objective. Figure 1.1.4 presents these facts.

Everyone has the objective of maximum profits but the means to accomplish this end is different:

- Vendor – designs for minimum cost
- Contractor – engineers and installs for minimum cost
- End user – must operate the custom designed equipment 24/7 for 30 years Therefore, the end users objectives can be directly opposed to the vendor’s and contractors!!!

Figure 1.1.4 The objective – maximum profits

It is important to remember these facts at all times during the entire project. The information contained in the following figure should be the basis for convincing the Project Team that all decisions regarding equipment purchase should be made on the basis of Process Unit life cycle cost and not capital cost and/or schedule considerations. The specific objectives of the end user are presented in Figure 1.1.5.

- Maximum machine reliability
- Minimum operating cost
- Minimum time to repair

These objectives result in..... maximum up time
which will yield maximum revenue
andmaximum profits
For the entire life cycle of the process unit!!

Figure 1.1.5 End user – Specific Objectives for Maximum Profit

The most important factor in life cycle cost considerations is daily revenue and obtaining this figure should be the number one priority in the early stages of the project. It will be a key fact in obtaining management support for your project action plans. Figure 1.1.6 presents these facts.

- Is the amount of revenue obtained in 24 hours of operation
- Trip of an un-spared item = exposure to revenue loss
- Daily revenue values can range from 1MM\$ to 5 MM\$+
- Always justify Project Scope requirements on the basis of daily revenue loss
- Assign an Actual Daily Revenue Loss amount to each proposed Best Practice if it is not implemented

Figure 1.1.6 Daily revenue

Therefore, the company life cycle revenue and profit, potential will be a result of incorporating all of your project best practice requirements into the project action plan at the first opportunity before the first project budget estimate is prepared. Figure 1.1.7 shows the advantages of incorporating this philosophy as early as possible into the project.

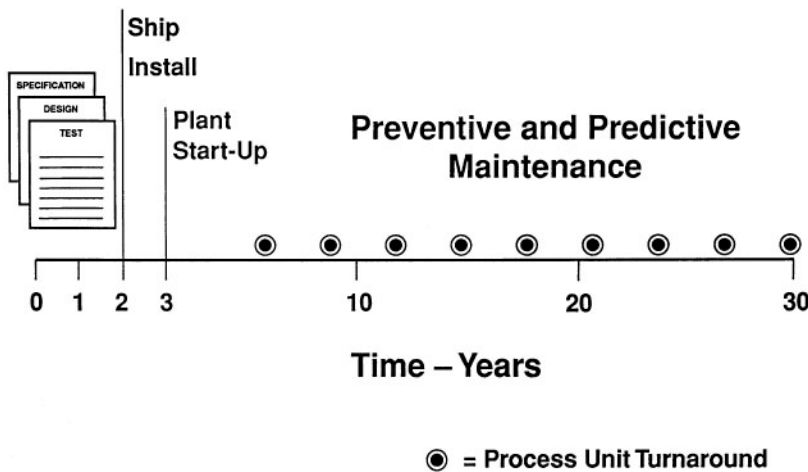

Figure 1.1.7 The life span of rotating equipment

This action should be taken when the project is first announced and the project team is assembled. The approach taken during the first 3–6 months after the initial project kick off will determine the level of reliability and life cycle cost savings for the entire life of the process unit (over 30 years). Most important is the necessity of establishing immediate creditability with the project team so that your ideas are implemented.

Hopefully, the above information will be of use in your project involvement in terms of lessons learned. The resulting best practices should be developed into a project philosophy that will eliminate all the issues noted above and will obtain and maintain your management's support throughout the entire project from the pre-feed phase to field operation.

Note that while this book is concerned with rotating equipment Best Practices, many of the principles in this Book are equally applicable to all assets included in a project.

B.P. 1.6 : Carefully state instructions to Quoting Vendors in the Invitation to Bid (ITB) Document.

The ITB is the only communication sent to quoting Vendors prior to discussions and/or meetings.

Clear Instructions are essential to minimum Vendor/Contractor/End User discussions and will greatly reduce time in determining the successful bidder.

Be sure to include final accepted Specifications, Data Sheets, Best Practices accepted for the Project and especially Pre- Bid (Bid Clarification) Meeting Instructions.

L.L: Absence or lack of ITB Vendor Instructions results in endless meetings, discussions and emails

Not accurately stating Vendor Instructions in the ITB will result in the following issues:

- Exceeding scheduled time for Bid review and Vendor Recommendations
- Unequal Technical Content in Vendor Bids
- Potential Reliability Issues resulting from lack of a detailed Bid review.(Bid Clarification Meetings)
- Excessive amount of exceptions to specifications, data sheets and Best Practices

BENCHMARKS:

This Best Practice has been used by the writer, especially for Critical (Un-Spared) equipment since the 1970's and assures optimum safety & reliability and maximum revenue over the life of the process. It has been incorporated Globally in all Upstream and Downstream Projects.

This approach has resulted in a “teamwork” spirit between EP&C's, Vendors and End Users because all parties know the rules and work mutually towards the stated objectives in the ITB Instructions.

SUPPORTING MATERIAL:

- Incorporate all project team accepted items (Design Audit, Best Practices, Pre-Bid Meetings, and Test Requirements etc.)
- Include Pre- Bid Meeting Instructions (when, where and who attends)
- Include Design Audit Details (when, where and who attends)
- Define discipline and experience requirements for all participants in all scheduled meetings
- Note penalty for non-compliance (eg, bid not accepted)

Figure 1.6.1 ITB instructions to vendors

B.P. 2.7: Operate centrifugal pumps within the “Equipment Reliability Operating Envelope” (EROE) to achieve maximum mean time between failure (MTBF).

The Equipment Reliability Operating Envelope (EROE) also called the “Heart of the Curve” assures maximum centrifugal pump MTBF by avoiding all operating areas of hydraulic disturbances.

We define the general EROE range as + 10% to -50% in flow from the pump Best Efficiency Point.

This range will be reduced for double flow pumps and high speed inducer (see B.P: 2.6) pumps.

Please refer to the supporting material below for additional details.

L.L: Failure to establish EROE limits will lead to low MTBF of centrifugal pumps We have found that approximately 80% of centrifugal pump reliability reduction (Sources of low MTBF) are due to process changes causing the pump to operate in either a high flow or low flow range that exposes the pump to hydraulic disturbances and resulting low MTBF.

Establishing operator EROE targets for all critical site pumps and all Bad Actor Pumps (Pumps with one or more component failures per year) will assure optimum centrifugal pump safety and MTBF's.

BENCHMARKS:

The writer has used this best practice since the late 1990's in refineries, chemical plants and in SAGD (Steam Assisted Gravity Drainage) applications in heavy oil fields. Once this best practice had been implemented, pump MTBF's that were less than 12 months (“Bad Actors”) were improved to greater than 80 months.

SUPPORTING MATERIAL:

EFFECTS OF THE PROCESS ON PUMP RELIABILITY AND MTBF

The effect of the process on machinery reliability is often neglected as a root cause of machinery failure. It is a fact that process condition changes can cause damage and/or failure to every major machinery component. For this discussion, the most common type of Driven Equipment — Pumps will be used.

There are two (2) major classifications of pumps, positive displacement and kinetic, centrifugal types being the most common. A positive displacement pump is shown in Figure 2.7.1. A centrifugal pump is shown in Figure 2.7.2

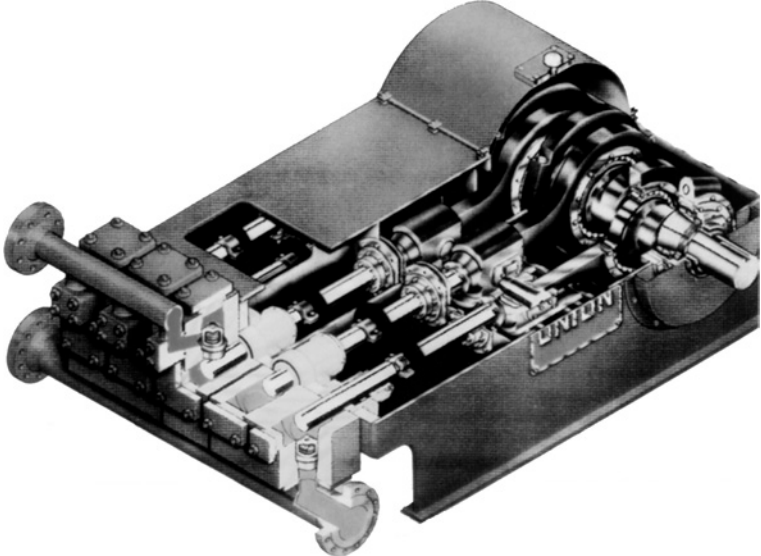

Figure 2.7.1 Positive displacement plunger pump

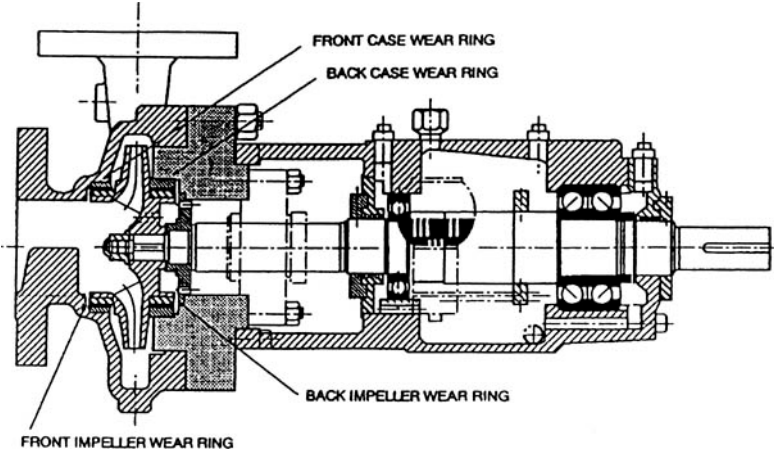

Figure 2.7.2 Centrifugal pump

It is most important to remember that all driven equipment (pumps, compressors, fans, etc.) react to the process system requirements. They do only what the process requires. This fact is noted in Figure 2.7.3 for pumps.

- Pumps produce the pressure required by the process
- The flow rate for the required pressure is dependent on the pump's characteristic

Figure 2.7.3 Pump performance

Centrifugal (Kinetic) Pumps and Their Drivers

Centrifugal pumps increase the pressure of the liquid by using rotating blades to increase the velocity of a liquid and then reduce the velocity of the liquid in the volute. Refer again to Figure 2.7.2.

A good analogy to this procedure is a football (soccer) game. When the ball (liquid molecule) is kicked, the leg (vane) increases its velocity. When the goal tender (volute), hopefully, catches the ball, its velocity is significantly reduced and the pressure in the ball (molecule) is increased. If an instant replay "freeze shot" picture is taken of the ball at this instant, the volume of the ball is reduced and the pressure is increased.

The characteristics of any centrifugal pump then are significantly different from positive displacement pumps and are noted in Figure 2.7.4.

- Variable flow
- Fixed differential pressure produced for a specific flow*
- Does not require a pressure limiting device
- Flow varies with differential pressure ($P_1 - P_2$) and/or specific gravity

*assuring specific gravity is constant

Figure 2.7.4 Centrifugal pump characteristics

Refer again to Figure 2.7.3 and note that all pumps react to the process requirements. Based on the characteristics of centrifugal pumps noted in Figure 2.7.4, the flow rate of all types of centrifugal pumps is affected by the Process System. This fact is shown in Figure 2.7.5.

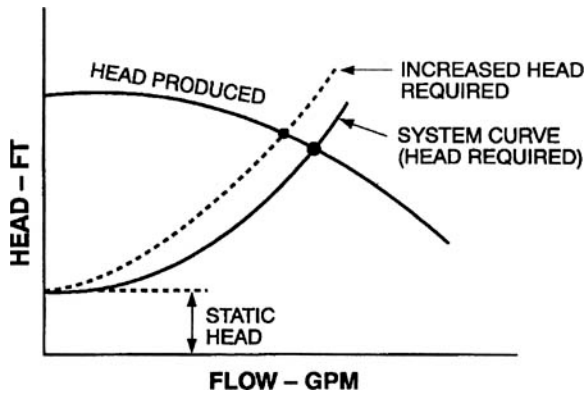

Figure 2.7.5 A centrifugal pump in a process system

Therefore, the flow rate of any centrifugal pump is affected by the process system. A typical process system with a centrifugal pump installed, is shown in Figure 2.7.6.

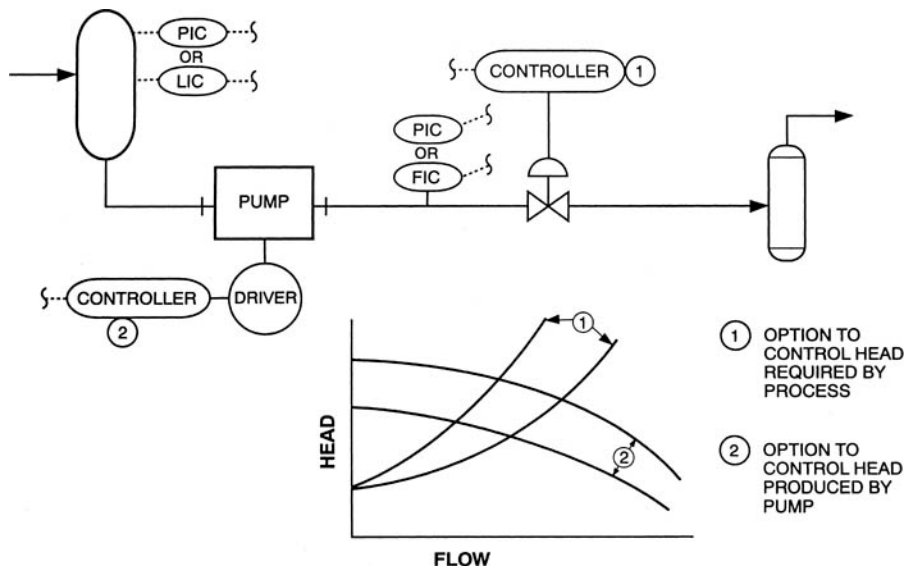

Figure 2.7.6 Centrifugal pump control options

The differential pressure required (proportional to head) by any process system is the result of the pressure & liquid level in the suction and discharge vessel and the system resistance (pressure drop) in the suction and discharge piping.

Therefore, the differential pressure required by the process can be changed by adjusting a control valve in the discharge line. Any of the following process variables (P.V.) shown in Figure 2.7.6, can be controlled:

- Level
- Pressure
- Flow

As shown in Figure 2.7.5, changing the head required by the process (differential pressure divided by specific gravity), will change the flow rate of any centrifugal pump!

Refer to Figure 2.7.7 and it can be observed that all types of mechanical failures can occur based on where the pump is operating based on the process requirements.

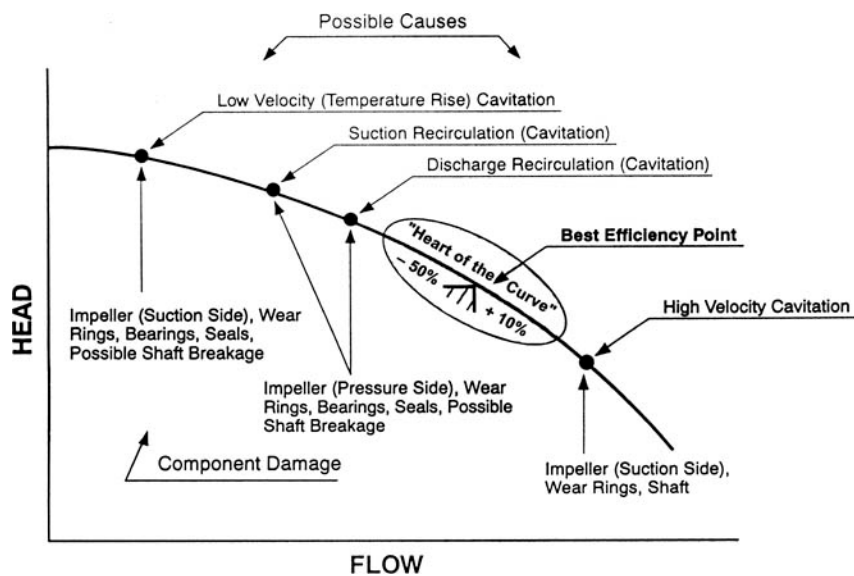

Figure 2.7.7 Centrifugal pump component damage and causes as a function of operating point

Since greater than 95% of the pumps used in this refinery are centrifugal, their operating flow will be affected by the process. Please refer to Figure 2.7.8 which shows centrifugal pump reliability and flow rate is affected by process system changes.

- Is affected by process system changes (system resistance and S.G.)
- It is not affected by the operators!
- Increased differential pressure ($P_2 - P_1$) means reduced flow rate
- Decreased differential pressure ($P_2 - P_1$) means increased flow rate

Figure 2.7.8 Centrifugal pump reliability

At this point it should be easy to see how we can condition monitor the centrifugal pump operating point. Refer to Figure 2.7.9.

- Monitor flow and check with reliability unit (RERU) for Significant changes
- Flow can also be monitored by:
 - Control valve position
 - Motor amps
 - Steam turbine valve position

Figure 2.7.9 Centrifugal pump practical condition monitoring

Driver reliability (motors, steam turbine and diesel engines) can also be affected by the process when centrifugal driven equipment (pumps, compressor and fans) are used.

Refer to Figure 2.7.10 and observe a typical centrifugal pump curve.

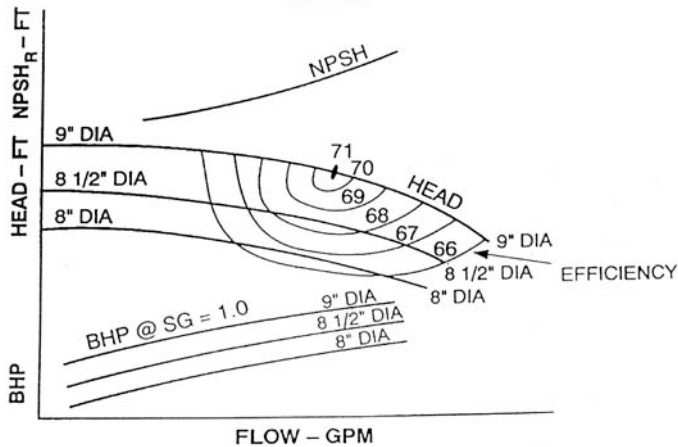

Figure 2.7.10 A typical centrifugal pump performance curve

Since the flow rate will be determined by the process requirements, the power (BHP) required by the driver will also be affected. What would occur if an 8 ½" diameter impeller were used and the head (differential pressure) required by the process was low? Answer: Since the pressure differential required is low, the flow rate will increase and for the 8 ½" diameter impeller, the power required by the driver (BHP) will increase.

Therefore, a motor can trip out on overload, a steam turbine's speed can reduce or a diesel engine can trip on high engine temperature. These facts are shown in Figure 2.7.11.

- Motors can trip on overload
- Steam turbines can reduce speed
- Diesel engines can trip on high engine temperature

Figure 2.7.11 Effect of the process on drivers

Auxiliary System Reliability is also affected by process changes. Auxiliary systems support the equipment and their components by providing ... clean, cool fluid to the components at the correct differential pressure, temperature and flow rate.

Typical auxiliary systems are:

- Lube Oil Systems
- Seal Flush System
- Seal Steam Quench System
- Cooling Water System

The reliability of machinery components (bearings, seals, etc.) is directly related to the reliability of the auxiliary system. In many cases, the root cause of the component failure is found in the supporting auxiliary system.

As an example, changes in auxiliary system supply temperature, resulting from cooling water temperature or ambient air temperature changes, can be the root cause of component failure. Figure 2.7.12 presents these facts.

- Is directly related to auxiliary system reliability
- Auxiliary system reliability is affected by process condition changes
- “Root causes” of component failure are often found in the auxiliary system

Figure 2.7.12 Effect of the process on drivers

As a result, the condition of all the auxiliary systems supporting a piece of equipment must be monitored. Please refer to Figure 2.7.13.

- Monitor auxiliary system condition
- Inspect auxiliary system during component replacement

Figure 2.7.13 Always “think system”

EROE (Equipment Reliability Operating Envelope) DETERMINATION

As noted in Figure 2.7.14, process changes will vary the flow of any centrifugal pump. If the centrifugal pump flow is too high or too low hydraulic disturbances will be present that can change the pumped fluid pressure and/or temperature. Since the majority of Mechanical Seal applications use the pumped fluid in the seal chamber, the seal chamber pressure and/or temperature will be affected. These changes will directly impact Mechanical Seal Life and Reliability.

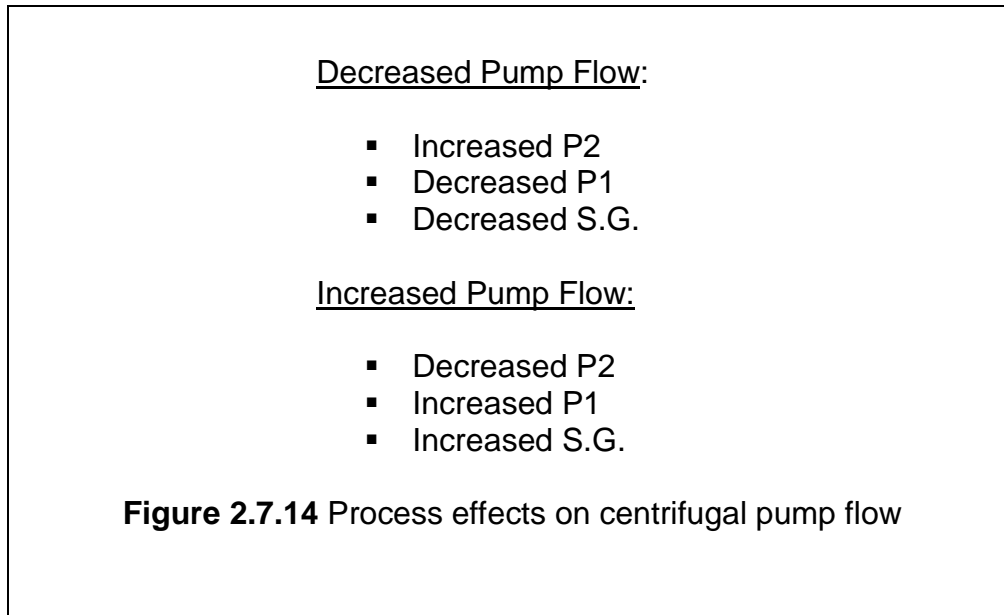

Figure 2.7.15 shows a typical centrifugal pump head vs. flow curve with the following items noted:

- The “Desirable Region” of Operation – Heart of the Curve or EROE
- Regions of Hydraulic Disturbances – On the upper portion of the curve
- The Pump Components affected – On the lower portion of the curve

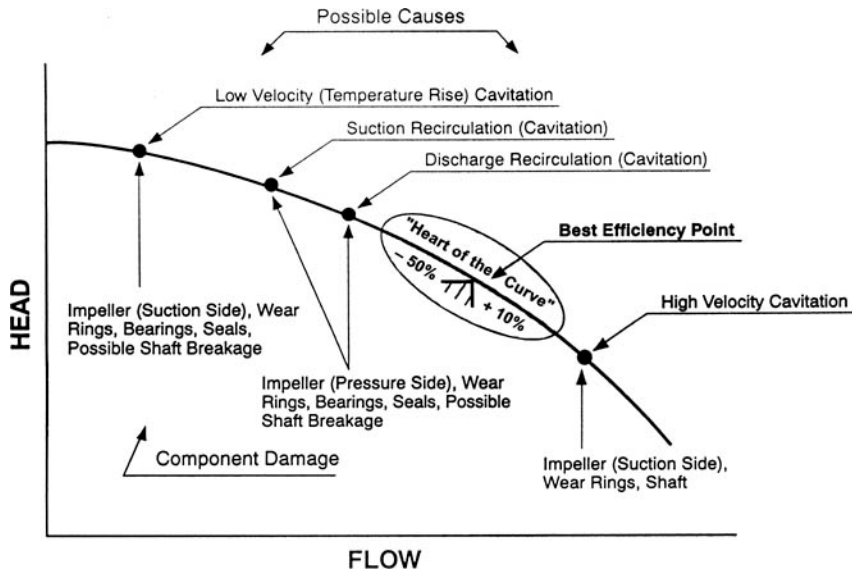

Figure 2.7.15 Centrifugal pump head vs. flow curve

The “Heart of the Curve” is the flow region for any centrifugal pump that will be free of Hydraulic Disturbances and where the seal fluid should be free of vapor if the seal fluid conditions stated on the Pump and Seal Data Sheets are present during pump field operation.

This Flow Region is also called the:

EROE – The Equipment Reliability Operating Envelope

Figure 2.7.16 presents facts concerning the EROE.

1. The eroe flow range is + 10% and – 50% of the pump best efficiency point (bep) flow
 2. All “bad actor pumps” – (more than one component failure per year) should be checked for eroe
 3. To determine that the pump is operating in eroe:
 - Calculate the pump head required
 - Measure the flow
 - Plot the intersection of head & flow on the pump shop test curve
- Figure 2.7.16** E.R.O.E. Facts

In many Pump installations, a flow meter is not installed and a suction pressure gauge is not installed. A calibrated suction pressure gauge can be installed in the suction pipe drain connection (Always present). **Be sure to obtain a MOC (Management of Change) & Work Permit and any other plant required permission prior to installing a suction pressure gauge as the pumped fluid could be sour (H2S), Flammable and/or Carcinogenic.**

If a flow meter is not installed, Figure 2.7.17 defines the options available to determine the pump flow so the EROE can be obtained.

1. Measure motor amps and calculate power
2. Record control valve position, valve differential pressure, fluid s.g. and calculate valve flow (pump flow)
3. Measure pump pipe differential temperature and calculate pump efficiency
4. Obtain an ultrasonic flowmeter to measure flow
5. For items 1 & 3, locate the calculated value (power or efficiency) on the pump test curve to determine pump flow

Figure 2.7.17 Available pump flow determination options

The flow values in Figure 2.7.17 can be determined by hand calculations using the equations available in any pump text (Power Equation & Pump Temperature Rise Equation).

It can be seen that the EROE will provide a reasonable guide that usually will eliminate Hydraulic disturbances that can cause seal chamber pressures and temperatures to change and lead to premature seal wear and/or failure. Note that the stated EROE low flow range can be reduced if the pump or fluid have any of the following characteristics noted in Figure 2.7.18.

- Pumps with suction specific speeds > 8,000 (customary units)
- Double suction pumps
- Water pumps with low npsh margin
- Fluids with s.g. < 0.7
- Pumps with Inducers

Figure 2.7.18 Factors that can reduce low flow eroe range

Therefore, we always recommend that the first step in seal condition monitoring be determination of pump operation within its EROE. If the “Bad Actor” Pump is operating outside its EROE, we recommend the action shown in Figure 2.7.19.

- Consult operations to determine if process changes can be made to operate in eroe
- Define target eroe parameters for operations (flow, amps, control valve postion, delta T)

Figure 2.7.19 If a centrifugal pump is outside its EROE

If seal reliability does not improve when operating within the EROE, further investigation is required concerning the process conditions in the seal chamber and/or flush system.

B.P. 7.11: Always test oil system relief valves on the oil console and not on the PSV Test Rig to assure that the settings are not lower than specified.

All oil system relief valves are the modulating type.

Modulating type relief valves start to open at the specified set point but require additional pressure (“Accumulation”) to open fully.

PSV Test Rigs are set up for “Poppet” type relief valves that open fully at their set point.

Frequently, oil system relief valve set points are set erroneously for their full open set point on the PSV Test Rig which results in the relief valves opening prematurely when re-installed on the oil console.

Using a calibrated pressure gauge and testing the relief valves on the oil console saves time and assures the proper setting.

L.L: Many unit trips have been traced back to improper setting of relief valves that caused them to open at lower than set pressures which required the auxiliary pump to start. Starting of the auxiliary pump was either too late or caused control valve instability resulting in a low oil pressure trip and a unit trip.

BENCHMARKS:

The writer has used this best practice since the early 1980’s when he was commissioning a large petrochemical plant. Since that time, this advice when implemented has resulted in plant oil system and unit reliabilities above 99.7%.

SUPPORTING MATERIAL:

Relief valves for positive displacement pumps

Since positive displacement pumps are not self-limiting, i.e., they can produce increasing pressure if sufficient driver power is available, a device to limit pump pressure and horsepower is required.

The function of a relief valve as a protection device is to limit pump discharge pressure and horsepower to a specified value without generating any valve instabilities and to positively reseal. While the function of a relief valve is simple enough, valve chatter (instability) and failure to positively reseal can cause the shutdown of the critical equipment. Relief valve chatter can cause high pressure pulses that will activate shutdown pressure switches and damage valve seats and plugs.

The inability to reseal properly will introduce an ‘equivalent orifice’ into the system that will reduce or totally eliminate the system flow to the critical system components.

Experience has shown that a sliding piston type relief valve, which is a modulating device, as opposed to a spring loaded poppet valve, which is an on-off device, meets the requirements of stability and positive shutoff for liquid auxiliary system service. A typical relief valve used is shown in Figure 7.11.1. A sizing chart for this type of relief valve is shown in Figure 7.11.12. Relief valve set pressure is usually set 10% above the pump maximum discharge pressure. However, the maximum pressure ratings of all system components must also be considered.

Given the maximum pump flow and the relief valve set pressure, the maximum system pressure can be determined as follows:

Maximum system pressure = relief valve set pressure + relief valve overpressure.
 Relief valve overpressure is the valve pressure drop necessary to pass full pump flow.
 For the present example using a 2" valve:

1. Maximum pump discharge pressure = 200 PSIG
2. Relief valve set pressure (cracking pressure) = 1.1 × 200 = 220 PSIG
3. Maximum system overpressure = 220 PSIG + 25 PSIG = 245 PSIG (from Figure 7.11.2 for Y spring and 86 GPM flow)

Note that the overpressure values are viscosity sensitive and can be used up to a viscosity of 500 SSU. Above this value, the overpressure can be estimated to vary by the relationship:

$$\begin{aligned} \text{overpressure}_{@ \text{viscosity}} &= \text{overpressure}_{@ 500 \text{ SSU}} \times \sqrt[4]{\frac{\text{viscosity}}{500 \text{ SSU}}} \\ &= 35 \text{ psi} \sqrt[4]{\frac{1000}{500}} \\ &= 35 \text{ psi} \times 1.19 \\ &= 42 \text{ psi} \end{aligned}$$

Therefore, the maximum pressure at 1000 SSU will be 262 psi or 19%.

Relief valve overpressure expressed as a percentage of relief valve set point is defined as *accumulation*. Typical values of accumulation vary between 10 and 20%.

DIMENSIONS

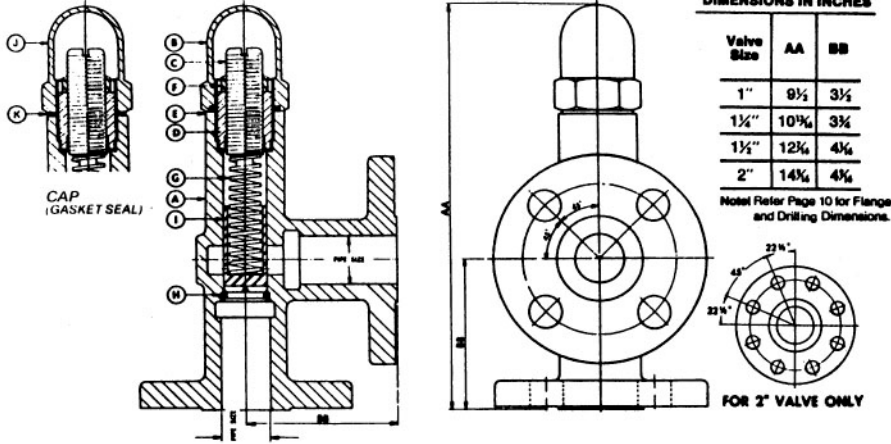

PARTS LIST

SYM.	NAME	MODEL	VALVE SIZE			
			1"	1 1/2"	1 1/2"	2"
A	BODY	VJF, VJF-SP VBF VSF VSSF	500-F 500-BF 500-SF 500-SSF	600-F 600-BF 600-SF 600-SSF	700-F 700-BF 700-SF 700-SSF	800-F 800-BF 800-SF 800-SSF
B	CAP (GASKET SEAL)	VJF, VJF-SP VBF VSF VSSF	501-R 501-BR 501-SR 501-SS	601-R 601-BR 601-SR 601-SS	701-R 701-BR 701-SR 701-SS	801-R 801-BR 801-SR 801-SS
C	ADJUSTING SCREW	VJF, VBF VSF, VJF-SP VSSF	502-B 502-S 502-SS	602-B 602-S 602-SS	702-B 702-S 702-SS	802-B 802-S 802-SS
D	RETAINER	VJF, VBF VSF, VJF-SP VSSF	503-B 503-S 503-SS	603-B 603-S 603-SS	703-B 703-S 703-SS	803-B 803-S 803-SS
E	O-RING †	VJF, VJF-SP VBF, VSF VSSF	504-* 504-RT	604-* 604-RT	704-* 704-RT	804-* 804-RT
F	LOCKNUT	VJF, VJF-SP VBF, VSF VSSF	505-S 505-SS	605-S 605-SS	705-S 705-SS	805-S 805-SS
G	SPRING †	ALL MODELS	507-**	607-**	707-**	807-**
H	STOP RING	VJF, VBF VJF-SP, VSF VSSF	508-B 508-S 508-SS	608-B 608-S 608-SS	708-B 708-S 708-SS	808-B 808-S 808-SS
I	PISTON †	416 STAINLESS STEEL HARDENED STEEL 316 STAINLESS STEEL	506-A 506-S 506-SS	606-A 606-S 606-SS	706-A 706-S 706-SS	806-A 806-S 806-SS
J	CAP (GASKET SEAL)	VJF, VJF-SP VBF VSF	501 501-B 501-S	601 601-B 601-S	701 701-B 701-S	801 801-B 801-S
K	GASKET †	VJF, VBF VJF-SP, VSF	504 504-S	604 604-S	704 704-S	804 804-S

*See O-ring selection chart
 **See spring pressure chart
 † Recommended spare parts

Figure 7.11.1 Modulating relief valve (Courtesy of Fulflow Specialties Co. Inc.)

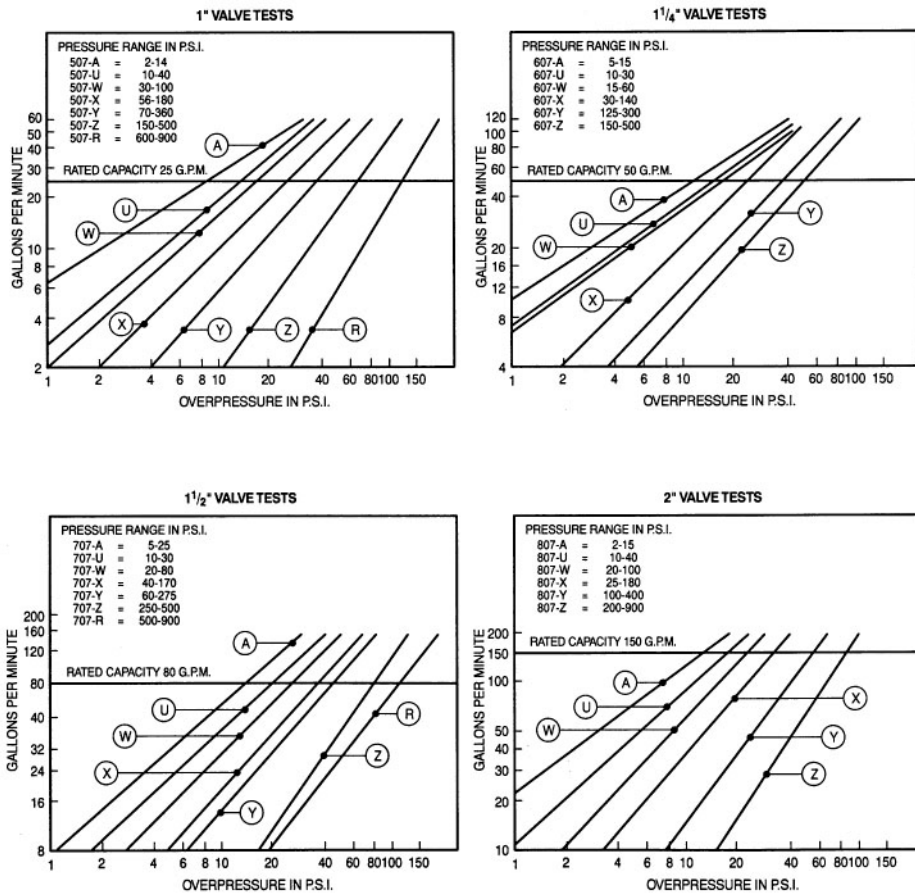

Figure 7.11.2 Relief valve sizing chart (Courtesy of Fulflow Specialties Co. Inc.)

B.P. 7.14: Install dual SS accumulators in Critical Equipment lube oil systems to positively prevent unit low oil pressure trips during transient events.

Even a properly designed lube oil system will eventually experience trips during transient events due to the following facts:

- The bypass (Backpressure) valve response will change (Packing friction)
- The bypass (Backpressure) valve sensing line pulsation valve can become clogged
- The auxiliary pump start time will increase (Electrical system changes)

Installation of two (2) Stainless Steel accumulators each sized for 4 seconds of oil supply will prevent unit low pressure trips and allow plant personnel to check accumulator pre-charge and bladder condition periodically (every 3 months) without taking the accumulator function out of service.

It is also recommended that an orifice bypass line with a globe valve be installed around (In parallel) the accumulator supply line for personnel use to assure that the accumulator is put back into service slowly to prevent a decrease in oil pressure.

Oil systems can be easily modified for installation of an accumulator during a turnaround.

L.L: Lube oil systems installed without accumulators will eventually cause critical (Un-spared) unit trips that will expose the end user to significant revenue losses.

It has been the writer's experience that clients with critical lube oil systems without accumulators eventually install them after experiencing unit trips that can easily justify the modification costs.

BENCHMARKS:

This best practice has been used by the writer since the 1990's when FAI performed numerous field audits for auxiliary systems. Installed accumulators immediately increased critical unit MTBF's and made large increases in unit reliability.

SUPPORTING MATERIAL:

An accumulator is simply a vessel which compensates for rapid short term flow disturbances in the auxiliary system. Most accumulators contain bladders (see Figure 7.14.1). It is important to remember that transient disturbances are on the order of micro seconds and usually less than five seconds in duration.

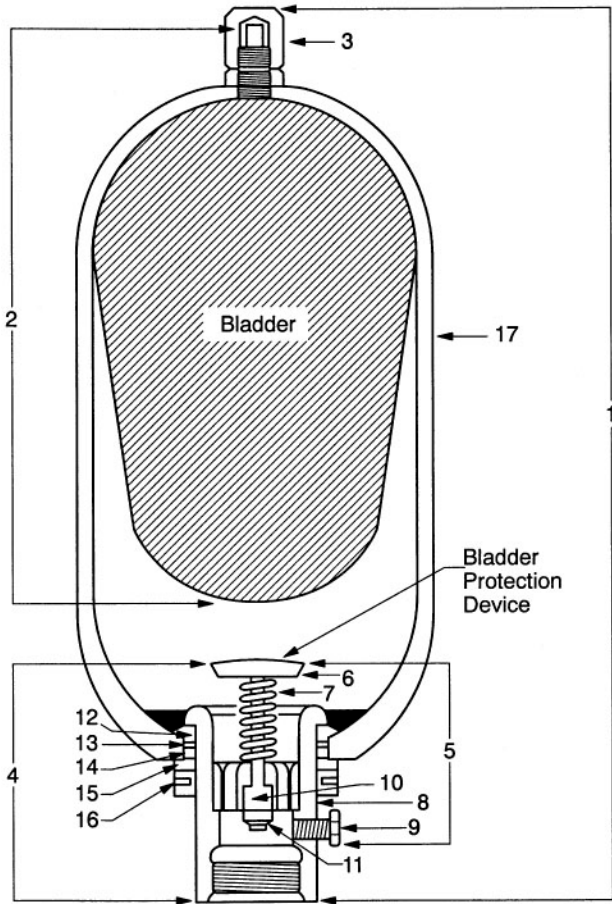

Figure 7.14.1 Typical oil system accumulator (Courtesy of Greer)

A schematic for a pre-charged accumulator is shown in Figure 7.14.2.

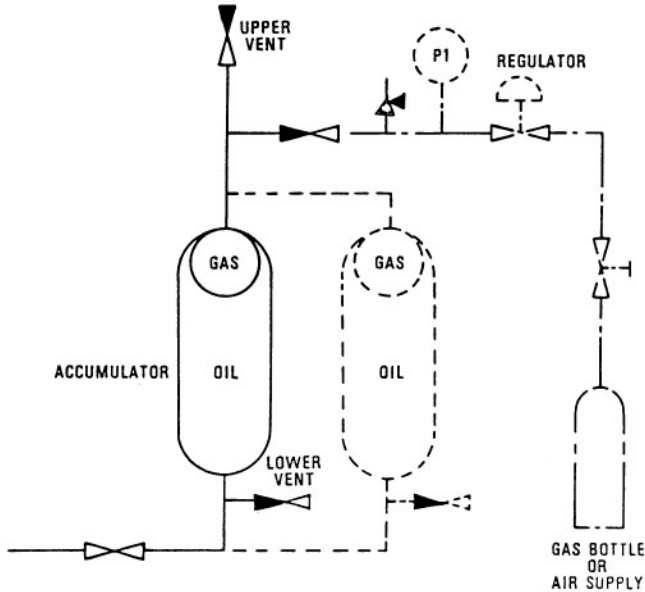

Figure 7.14.2 Accumulator precharging arrangement (Courtesy of Elliott Co.)

The pre-charge pressure is set at the pressure that the volume of the accumulator flow is required in the system. (This value is usually around 60–70% of the normal header pressure in which the accumulator is installed.) The quantity of oil available from a pre-charged accumulator is extremely low.

As an example, a system with a flow capacity of 120 GPM has a motor driven auxiliary pump that requires three seconds to attain full speed when started by a pressure switch or transmitter at 140 PSIG. Normal header pressure equals 160 PSIG. Determine the amount of oil required to prevent the pump header pressure from falling below 100 PSIG and the number of pre-charged 10 gallon accumulators required. (See Figure 7.14.3.)

Many times an accumulator is improperly sized because of the misconception that its stated size is in fact the capacity contained therein. Actual capacity in any accumulator is equal to the internal volume minus the gas volume over the liquid volume. Typically these values are 50% of the stated capacity or less.

Given:

- System required flow = 120 GPM
- System pressure at accumulator (at which accumulator effect is desired) = 140 PSIG – 154.7 PSIA (P₂)
- Gas precharge pressure (pressure at which accumulator oil flow ceases, assuming system pressure does not fall below this level) = 110 PSIG = 124.7 PSIA (P₁)
- Volume of accumulator = 9 gallons (V_a) (accounts for volume of internal parts)

Determine:

- Amount of oil required
- Number of 10 gallon accumulators required

Amount of oil required:

- System flow per second = $\frac{120 \text{ Gal/Min}}{60 \text{ Sec/Min}}$
= 2 Gal/Sec

Figure 7.14.3 Accumulator sizing

- Oil required = 3 Sec. × 2 Gal/Sec
= 6 Gallons
- Volume of oil entering system for each 10 gallon accumulator.

$$V_{oil} = (V_a) \left[1 - \left(\frac{P_1}{P_2} \right) \right]$$

$$= (9 \text{ Gal}) \left[1 - \left(\frac{124.7}{154.7} \right) \right]$$

= 1.75 Gal. per accumulator

- Number of 10 gallon accumulators required

$$\text{Number of 10 gallon accumulators} = \frac{\text{Oil quantity required}}{\text{Quantity available per accum.}}$$

$$= \frac{6 \text{ Gal.}}{1.75 \text{ Gal.}}$$

= 3.42 accumulators required

= four 10 Gal. accumulators

This is a large number of accumulators and is caused by:

The conservative setting of P2 and the neglect of the effect of system control valves and partial auxiliary pump flow during pump acceleration.

Let's set P2 just (1 PSIG) below the normal header setting and recalculate the number of accumulators required.

$$V_{oil} = (9 \text{ Gal}) \left[1 - \left(\frac{124.7}{175.7} \right) \right]$$

= 2.6 Gal/accumulator

= 3 accumulators required

The above example demonstrates the importance of properly sizing an accumulator.

Figure 7.14.3 Continued – accumulator sizing

System reliability considerations

Concerning auxiliary system control and instrumentation, a number of reliability considerations are worthy of mention.

Control valve instability

Control valve instability can be the result of many factors. To name a few; improper valve sizing, improper valve actuators, air in hydraulic lines or water in pneumatic lines. Control valve sensing lines should always be supplied with bleeders to assure that liquid in pneumatic lines or air in hydraulic lines is not present. Presence of these fluids will usually cause instability in the system. Control valve hunting is usually a result of improper controller setting on systems with pneumatic actuators. Attention is drawn to instruction books to insure that proper settings are maintained. Frequently direct acting control valves exhibit instabilities (hunting on transient system changes). If checks for

air prove inconclusive, it is recommended that a snubber device mentioned previously be incorporated in the system to prevent instabilities. Some manufacturers install orifices which sufficiently dampen the system. If systems suddenly act up where problems previously did not exist, any snubber device or orifice installed in the sensor line should be checked immediately for plugging.

Excessive valve stem friction

Control valves should be stroked as frequently as possible to assure minimum valve stem friction. Excessive valve stem friction can cause control valve instabilities or unit trips.

Control valve excessive noise or unit trips

Squealing noises suddenly produced from control valves may indicate valve operation at low travel (C_v) conditions. Valves installed in bypass functions that exhibit this characteristic may be signaling excessive flow to the unit. Remember the concept of control valves being crude flow meters. Observation of valve travel periodically during operation of the unit will indicate any significant flow changes.

Control valve sensing lines

Frequently, plugged or closed control valve sensing lines can be a root cause of auxiliary system problems. If a sensing line that is dead ended (see Figure 7.13.7) is plugged or closed at its source, a bypass valve will not respond to system flow changes and could cause a unit shutdown. Conversely, if a valve sensing line has a bleed orifice back to the reservoir (to assure proper oil viscosity in low temperature regions), plugging or closing the supply line will cause a bypass valve to fully close rendering it inoperable and may force open the relief valve in a positive displacement pump system.

Valve actuator failure modes

Auxiliary system control valve failure modes should be designed to prevent critical equipment shutdown in case of actuator failure. Operators should observe valve stem travel and pressure gauges to confirm valve actuator condition. In the event of actuator failure, the control valve should be designed for isolation and bypass while on line. This design will permit valve or actuator change out without shutting down the critical equipment. During control valve on line maintenance, an operator should be constantly present to monitor and modulate the control valve manual bypass as required.

Accumulator considerations

Concerning accumulators, checks should be made when unit is shut down for accumulator bladder condition if supplied with bladders. One area which can cause significant problems in auxiliary systems are accumulators supplied with a continuous charge. That is, charge lines (nitrogen or air) that come directly from a plant utility system. Any rupture of a diaphragm will provide a means for entrance of charge gas directly into the lube system. Most plant utility lines contain pipe scale that could easily

plug systems and cause significant critical equipment damage.

In addition, the following reliability factors should be noted (refer to Figure 7.14.2):

- Be sure to install a check valve upstream of the accumulators to assure all accumulator oil is delivered to the desired components.
- Accumulators should be checked periodically (monthly) for proper pre-charge and bladder condition by isolating and draining the accumulator. Note that the accumulator pre-charge pressure cannot be determined while on line
- When refilling the accumulators, care must be taken not to suddenly open the supply valve. Best practice is to install an orificed bypass valve to be used for filling the accumulator.
- Best practice is also to install two (2) full size accumulators to assure that one accumulator is always on line during monthly checks.

B.P. 9.1: To assure optimum safety and reliability of dry gas seal systems, end user's must be proactive in the project phase or during seal system modifications to specify:

- All possible operating, start up and upset conditions on the seal data sheet
- Required system design details by incorporating all site, company and industry lessons learned into the project or revamp specification
- A detailed (P & ID) and data sheet to quoting machinery vendors that will completely specify system and component design

Allowing the EP& C (Contractor) and/or machinery vendor to design the dry gas seal system will expose the plant to safety and reliability issues that cannot be known by other parties.

Following the guidelines completely in this best practice and requiring compliance with all specified details will assure a safe and trouble-free system of the highest reliability.

L.L: Failure to consider specific plant operating conditions and seal system lessons learned has resulted in dry gas seal systems of low MTBF (Less than 12 months) and large revenue losses.

The following examples highlight omitted details in dry gas seal specifications that have resulted in seal MTBF's less than 12 months:

- Failure to identify the actual gas properties (Sour gas, gas composition)
- Failure to identify saturated seal gas conditions at start-up, upset or operating conditions
- Failure to properly specify maximum flare header pressure
- Failure to define the actual dew point of supplied Nitrogen for intermediate & separation gas
- Failure to prohibit the use of orifices in the secondary vent resulting in seal pressure reversals
- Failure to specify oil sampling devices in the secondary seal vent port (Sight glasses, valves or automatic drainers) leading to secondary seal oil contamination and eventual failure.

BENCHMARKS:

The writer has used this best practice since the late 1990's to specify dry gas seal system requirements during projects and for field modifications. This approach has resulted in dry gas seal systems of the highest safety levels and reliability. (Seal MTBF's greater than 90 months).

SUPPORTING MATERIAL:

Dry Gas Seal (DGS) systems have been used for the past two decades, and are specified by many end users as the seal of choice for most compressor applications. One would therefore think that seal and system designs are well-known and proven. However, experience shows that failures

are still quite common. For instance, in 2007, FAI dealt with nearly 50 DGS failures.

These failures raise several questions. Are they all caused by “foreign material” contamination or ingestion? Are they connected with improper seal selection or unreliable system hardware? Who is responsible: seal vendors, compressor vendors, or end-users?

In reviewing DGS failures experienced in 2006 and previous years, the conclusion is that in a majority of cases, the root cause is that the seal and system configuration were not designed to handle all the actual site operating conditions, including startup, shut-down and upsets that should and could have been anticipated.

The end-user has the most complete knowledge of the process and plant operating procedures. Therefore, he or she needs to be proactive in terms of project DGS requirements, and specify the type of seal and system most suited to the plant and application, based on his or her knowledge and experience. Seal and compressor vendor input and experience are obviously required, but neglecting to evaluate the proposed system in detail against all operating modes subjects the user to the risk of unacceptable downtime and revenue losses, particularly in the “mega plants” being built today.

Figure 9.1.1 shows a recommended “Best Practice” P & ID for a tandem dry gas seal system in a critical (unspared) application used in a large plant of high daily revenue (greater than \$1MM/day).

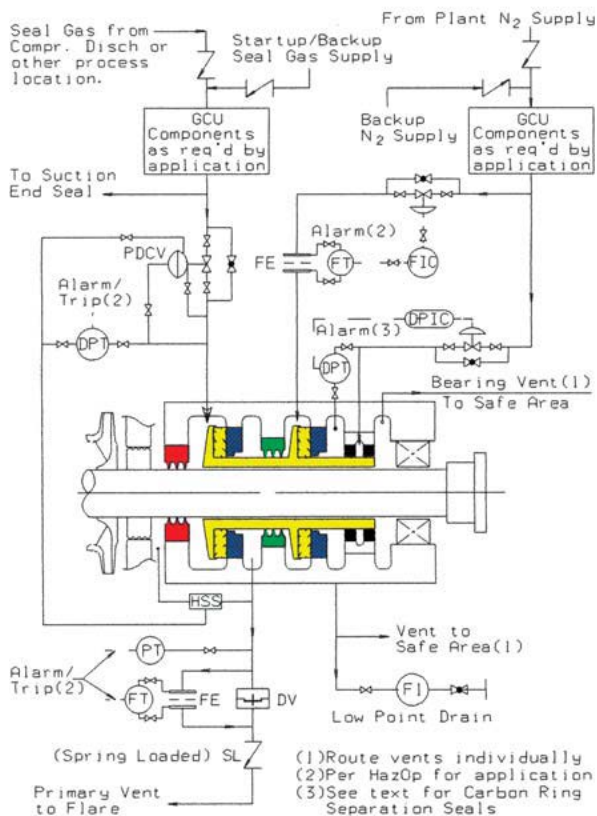

Figure 9.1.1 Best Practice Tandem Seal P & ID

The reliability of critical equipment is dependent on the reliability of each component in every auxiliary system connected with the critical equipment unit. How do we maximize critical equipment reliability? The easiest way is to eliminate the auxiliary systems. Imagine the opportunity to eliminate all of the components; pumps, filters, reservoirs, etc. and thereby increase reliability and hopefully, the safety of the equipment. The gas seal as used in compressor applications affords the opportunity to achieve these objectives. However, the gas seal is still part of a system and the entire gas seal system must be properly specified, designed, maintained and operated to achieve the objectives of optimum safety and reliability of the critical equipment.

In this section, the principles of gas seal design will be discussed and applied to various gas seal system types. In addition, best practices will be discussed for saturated gas systems as well as shutdown philosophies.

System function

The function of a gas seal system is naturally the same as a liquid seal system. The function of a fluid seal system, remembering that a fluid can be a liquid or a gas is to continuously supply clean fluid to each specified seal interface point at the required differential pressure, temperature, and flow rate. Therefore, one would

expect the design of a gas seal and a liquid seal to be very similar, which, in fact, they are. Then why are their systems so different?

Comparison of a liquid and gas sealing system

Figure 9.1.2 shows a liquid sealing system. Compare this system to Figure 9.1.3 which shows a gas seal system, if the same compressor were retrofitted for a gas seal. WOW!! What a difference. Why are there such a small amount of components for the gas seal system? As an aid, refer to Figure 9.1.4 which shows a typical pump liquid flush system as specified by the American Petroleum Institute. This system incorporates a liquid mechanical seal and utilizes pump discharge liquid as a flush for the seal. Refer now to Figure 9.1.3 and observe the similarities. It should be evident that a gas seal system is simplified in compressor applications over a liquid seal system merely because the gas seal utilizes the process fluid. This is exactly the same case for a pump. By using the process fluid, and not a liquid, one can eliminate the need to separate liquid from a gas, thereby totally eliminating the need for a liquid supply system and the need for a contaminated liquid (sour oil), drain system.

NOTE
 LEVEL IN OIL TANK IS
 MAINTAINED APPROX. 14"
 ABOVE CENTERLINE OF
 COMPRESSOR SHAFT

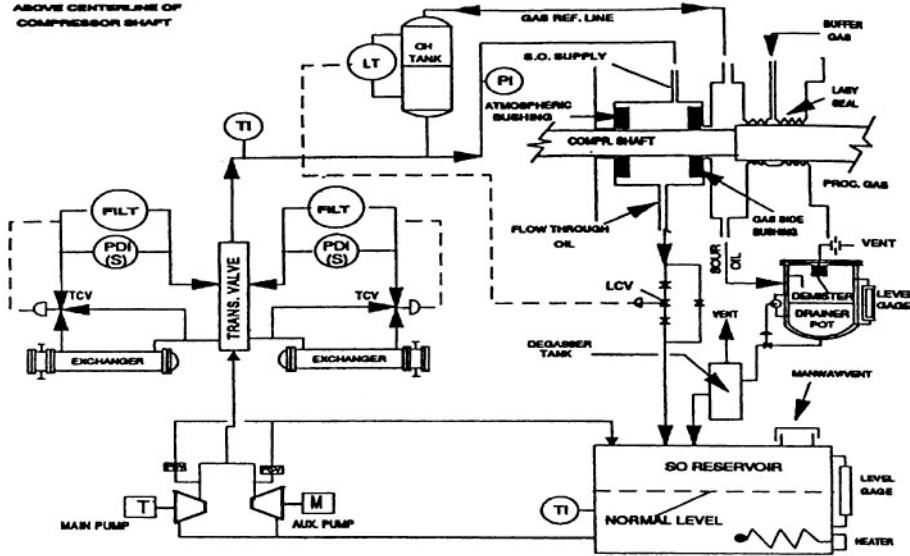

Figure 9.1.2 Typical seal oil system for clearance bushing seal (Courtesy of M.E. Crane Consultant)

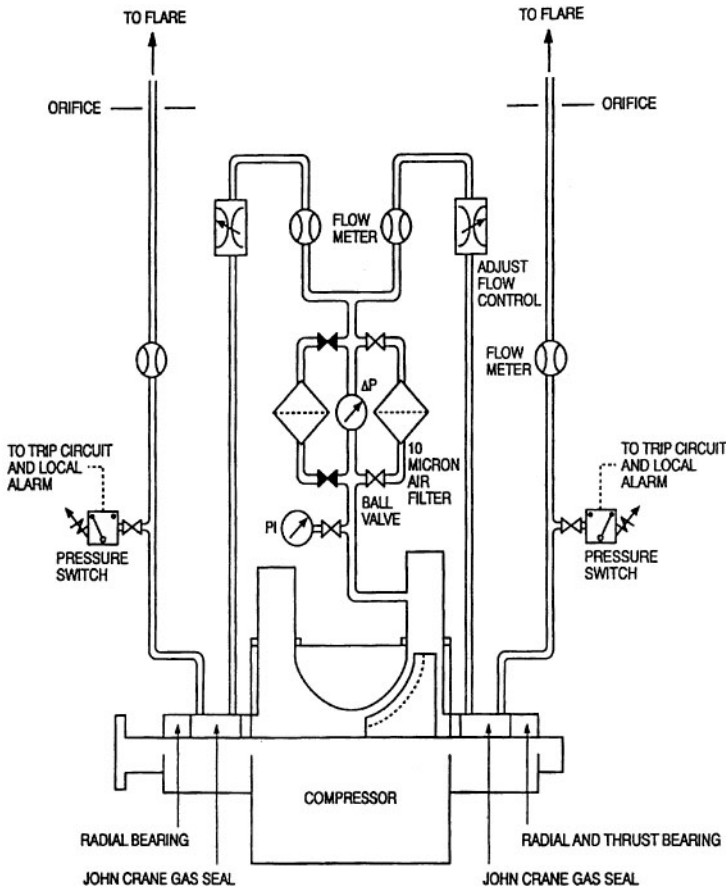

Figure 9.1.3 Typical gas seal system for dry air or inert gas (Courtesy of John Crane Co.)

Referring back to Figure 9.1.2, therefore, we can see that the following major components are eliminated:

1. The seal oil reservoir
2. The pumping units
3. The exchangers
4. The temperature control valves
5. The overhead tank
6. The drain pot
7. The degassing tank
8. All control valves
9. A significant amount of instrumentation

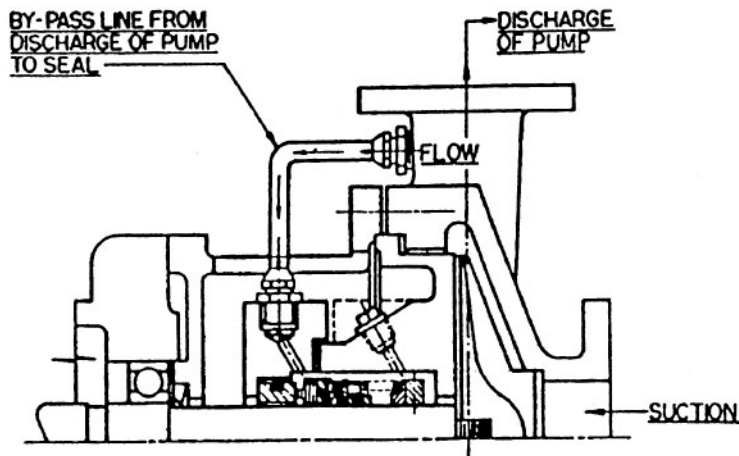

Figure 9.1.4 Liquid seal flush (Courtesy of John Crane Co.)

Referring back to the function definition of the gas seal system, all requirements are met. 'Continuously supplying fluid' is met by utilizing the discharge pressure of the compressor. The requirements for 'specified differential pressure, temperature and flow rate' are met by the design of the seal itself which can accommodate high differential pressures, high temperatures, and is sized to maintain a flow rate that will remove frictional heat necessary to maintain seal reliability. The only requirement not met is that of supplying a clean dry fluid, and this can be seen in Figure 9.1.3. This requirement is met by using a dual system coalescing filter.

When one considers all the advantages, the next question to ask is, okay, what are the disadvantages? Naturally, there are disadvantages. However, proper design of the gas seal system can minimize and eliminate many of the disadvantages. Do not forget that the requirements for any system mandate proper specification, design, manufacture, operation and maintenance. One can never eliminate these requirements in any critical equipment system.

Considerations for system design

As mentioned above, there are disadvantages to a gas seal system which are not insurmountable but must be considered in the design of such a system. These considerations

are as follows:

Sensitivity to dirt – since clearances between seal faces are usually less than 0.0005 inch and seal design is essential to proper operation, the fluid passing between the faces must be clean (5–10 microns maximum particle size). If it is not, the small grooves (indentations) necessary for seal face separation will become plugged thus causing face contact and seal failure.

Sensitivity to saturated gas – saturated fluids increase the probability of groove (indentation) blockage.

Lift-off speed – as will be explained below, a minimum speed is required for operation. Care must be taken in variable speed operation to assure that operation is always above this speed. It is recommended that the seal test be conducted for a period at turning gear speed to confirm proper ‘lift off’ followed by seal face inspection.

Positive prevention of toxic gas leaks to atmosphere – since all seals leak, the system must be designed to preclude the possibility of toxic or flammable gas leaks out of the system. This will be discussed in detail below.

Possible oil ingestion from the lube system – a suitable separation seal must be provided to eliminate the possibility of oil ingestion from the bearings. Whenever a gas seal system is utilized, the design of the critical equipment by definition incorporates a separate lube oil and seal system. Consideration must be given during the design or retrofit phases to the separation between the liquid (lube) and gas seal system.

‘O’ ring (secondary seal components) design and maintenance – most seal vendors state that ‘O’ ring life is limited and should be changed every five years for operating seals as well as spare seals. The writer’s experience has shown that dry gas ‘O’ ring seals can exceed this limit. It is recommended that seal vendors be required to provide references for similar applications prior to making a decision to change out the seals after five years.

If all of the above considerations are incorporated in the design of a gas seal system, its reliability has the potential to exceed that of a liquid seal system and the operating costs can be reduced.

Before moving to the next section, however, one must consider that relative reliability between gas and liquid seal systems are a function of proper specification, design, etc. as mentioned previously. A properly designed liquid seal system that is operated and maintained can achieve reliabilities of a gas seal system. Also, when one considers operating costs of the two systems, various factors must be considered. While the loss of costly seal oil is positively eliminated, with a gas seal system (assuming oil ingestion from the lube system does not occur) the loss of process gas, while minimal, can be expensive. It is argued that the loss of process gas from a liquid seal system through drainer vents and degassing tank vents, is also significant. While this may be true in many cases, a properly specified, designed and operated liquid seal system can minimize process gas leakage such that it is equal or even less than that of a gas seal.

There is no question that gas seal systems contain far fewer components and are easier to

maintain than liquid seal systems. These systems will be used extensively in the years ahead. The intention of this discussion is to point out that existing liquid seal systems that cannot be justified for retrofit or cannot be retrofitted easily, can be modified to minimize outward gas leakage and optimize safety and reliability.

Dry gas seal design

Principles of operation

The intention of this sub-section is to present a brief detail of the principles of operation of a dry gas seal in a conceptual form. The reader is directed to any of the good literature available on this subject for a detailed review of gas seal design. Refer to Figure 9.1.5.

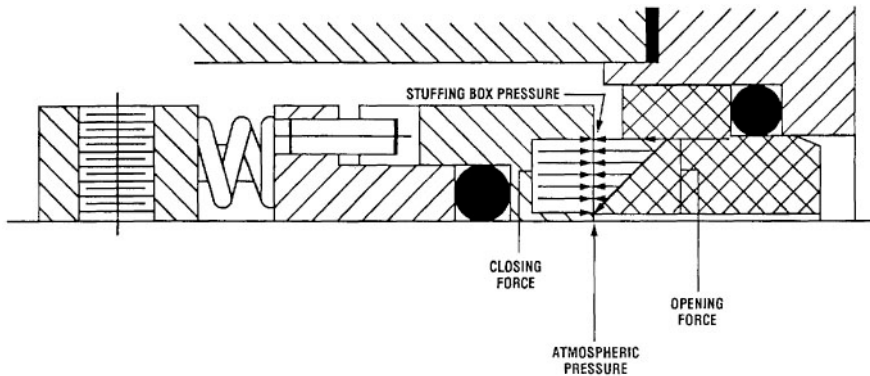

Figure 9.1.5 Typical pump single mechanical seal

Figure 9.1.5 shows a mechanical seal utilized for pump applications, while Figure 9.1.6 shows a dry gas mechanical seal utilized for compressor application. The seal designs appear to be almost identical. Close attention to Figure 9.1.6, however, will show reliefs of the rotating face of the seal.

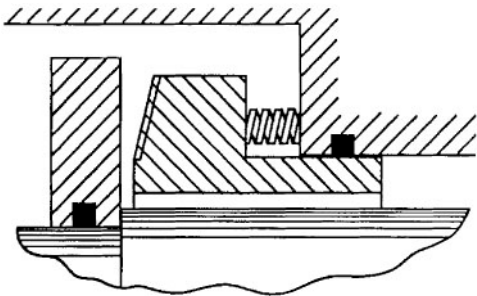

Figure 9.1.6 Typical design for curved face – spiral groove non-contact seal; curvature may alternately be on rotor (Courtesy of John Crane Co.)

Considering that both seals operate on a fluid may give some hint as to why the designs are very similar. The objective of seal designs is to positively minimize leakage while removing frictional heat to obtain reliable continuous operation of the seal. In a liquid application, the heat is removed by the fluid which passes between the rotating and stationary faces and the seal flush and changes from a liquid to gaseous state (heat of vaporization). This is precisely why all seals are said to leak and explains the recent movement in the industry to sealless

pumps in toxic or flammable service. If the fluid between the rotating faces now becomes a gas, its capacity to absorb frictional heat is significantly less than that of a liquid. Therefore an 'equivalent orifice' must continuously exist between the faces to reduce friction and allow a sufficient amount of fluid to pass and thus take away the heat. The problem obviously is how to obtain this 'equivalent orifice'. There are many different designs of gas seals. However, regardless of the design, the dynamic action of the rotating face must create a dynamic opening force that will overcome the static closing forces acting on the seal to create an opening and hence 'equivalent orifice'.

Refer to Figure 9.1.7 which shows a typical gas dry seal face. Notice the spiral grooves in this picture, they are typically machined at a depth of 100–400 micro inches.

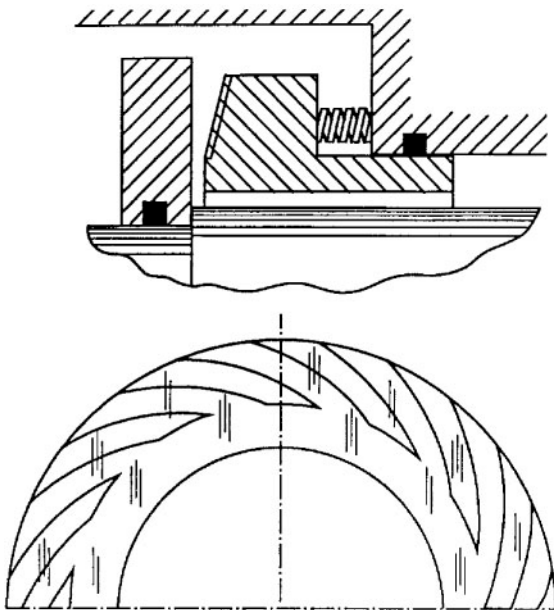

Figure 9.1.7 Dry gas seal. Top: typical design for curved face – spiral groove non-contact seal; curvature may alternately be on rotor; Bottom: Typical spiral groove pattern on face of seal typical non-contact gas seal (Courtesy of John Crane Co.)

When rotating, these vanes create a high head low flow impeller that pumps gas into the area between the stationary and the rotating face, thereby increasing the pressure between the faces. When this pressure is greater than the static pressure holding the faces together, the faces will separate thus forming an equivalent orifice. In this specific seal design, the annulus below the vanes forms a tight face such that under static (stationary) conditions, zero leakage can be obtained if the seal is properly pressure balanced. Refer to Figure 9.1.8 for a force diagram that shows how this operation occurs.

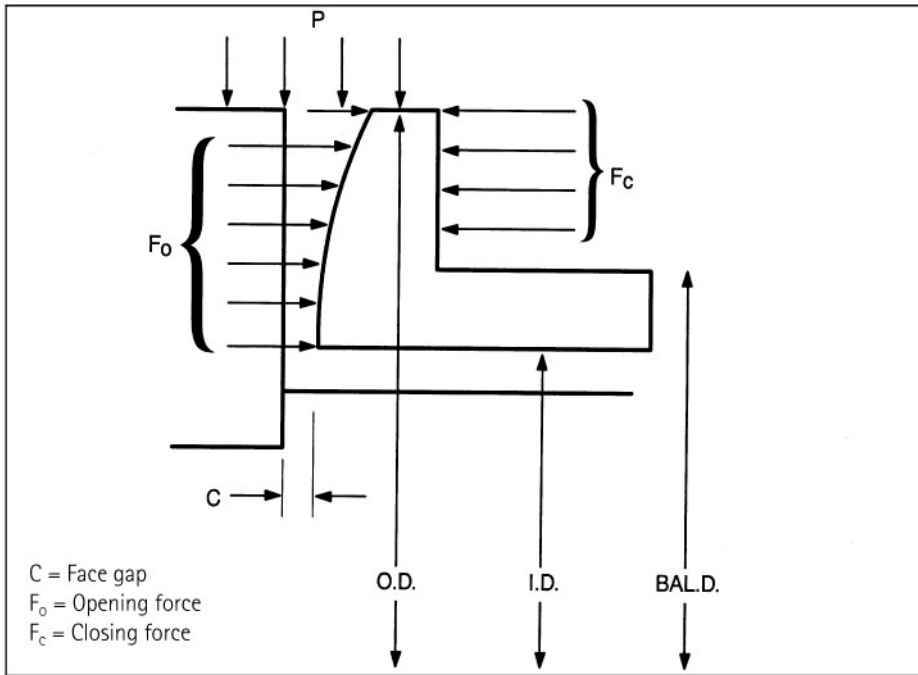

Figure 9.1.8 Hydrostatic force balance on seal stator ($F_c = F_o$) (Courtesy of John Crane Co.)

In Figure 9.1.7, the rotation of the face must be counter-clockwise to force the gas into the passages and create an opening (F_o) force. This design is known as a 'uni-directional' design and requires that the faces always operate in this direction. Alternative face designs are available that all rotate in either direction and they are known as 'bi-directional' designs.

Ranges of operation

Essentially, gas seals can be designed to operate at speeds and pressure differentials equal to or greater than those of liquid seals. Present state-of-the-art (2010) limits seal face differentials to approximately 17,250 kPa (2,500 psi) and rubbing speeds to approximately 122 meters/second (400 feet/second). Temperatures of operation can reach as high as 538°C (1,000°F). Where seal face differential exceeds these values, seals can be used in series (tandem) to meet specifications provided sufficient axial space is available in the seal housing.

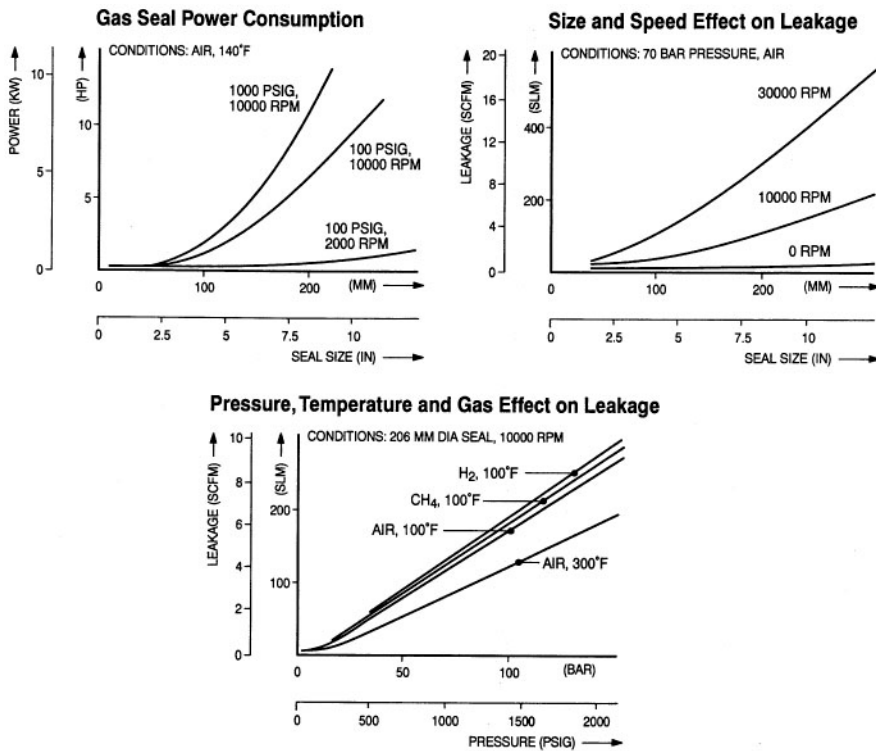

Figure 9.1.9 Dry gas seal leakage rates (Courtesy of John Crane Co.)

Leakage rates

Since the gas seal when operating forms an equivalent orifice, whose differential is equal to the supply pressure minus the seal reference pressure, there will always be a certain amount of leakage. Refer to Figure 9.1.9 for leakage graphs.

It can be stated in general that for most compressor applications with suction pressures on the order of 3,450 kPa (500 psi) and below, leakage can be maintained on the order of one standard cubic foot per minute per seal. For a high pressure application 17,250 kPa (2,500 psi), differential leakage values can be as high as 8.5 Nm³/hr (5 SCFM) per seal. As in any seal design, the total leakage is equal to the leakage across the seal faces and any leakage across secondary seals (O-rings, etc.). There have been reported incidence of explosive O-ring failure on rapid decompression of systems incorporating gas seals, thus resulting in excessive leakage. Consideration must be given to the system in order to tailor system decompression times in order to meet the requirements of the secondary seals. As previously mentioned, all gas seals will leak, but not until the face 'lifts off'. This speed known, oddly enough, as 'lift off speed' is usually less than 500 rpm. Caution must be exercised in variable speed applications to assure the system prevents the operation of the variable speed driver below this minimum lift off value. One recommendation concerning instrumentation is to provide one or two thermocouples in the stationary face of each seal to measure seal face temperature. This information is very valuable in determining lift off speed and condition of the grooves in the rotating seal face. Any clogging of these grooves will result in a higher face temperature and will be a good indication of requirement for seal maintenance.

Gas seal system types

As mentioned in this section, in order to assure the safety and reliability of gas seals, the system must be properly specified and designed. Listed below are typical gas seal system applications in use today.

Low/medium pressure applications – dry air or inert gas

Figure 9.1.3 shows such a system. This system incorporating a single dry gas seal is identical to that of a liquid pump flush system incorporating relatively clean fluid that meets the requirements of the seal in terms of temperature and pressure. This system takes the motive fluid from the discharge of the compressor through dual filters (ten microns or less) incorporating a differential pressure gage and proportions equal flow through flow meters to each seal on the compressor. Compressors are usually pressure balanced such that the pressure on each end is approximately equal to the suction pressure of the compressor. The clean gas then enters the seal chamber and has two main paths:

- A. Through the internal labyrinth back to the compressor. Note that the majority of supplied gas takes this path for cooling purposes (99%).
- B. Across the seal face and back to either the suction of the compressor or to vent.

Since the gas in this application is inert, it can be vented directly to the atmosphere or can be put back to the compressor suction. It must be noted, however, that this port is next to the journal bearing. Therefore a means of positively preventing entry of lube oil into this port must be provided in order to prevent the loss of lube oil or prevent the ingestion of lube oil into the compressor if this line is referenced back to the compressor suction. A suitable design must be incorporated for this bushing. Typically called a disaster bushing, it serves a dual purpose of isolating the lube system from the seal system and providing a means to minimize leakage of process fluid into the lube system in the event of a gas seal failure. In this system, a pressure switch upstream of an orifice in a vent line is used as an alarm and a shutdown to monitor flow. This switch uses the concept of an equivalent vessel in that increased seal leakage will increase the rate of supply versus demand flow in the equivalent vessel (pipe) and result in a higher pressure. When a high flow is reached, the orifice and pressure switch setting are thus sized and selected to alarm and shut down the unit if necessary. As in any system, close attention to changes in operating parameters are required. Flow meters must be properly sized and maintained clean such that relative changes in the flows can be detected in order to adequately plan for seal maintenance.

High pressure applications

In this application, for pressures in excess of 6,895 kPa (1,000 psi), a tandem seal arrangement or series seal arrangement is usually used. Since failure of the inner seal would cause significant upset of the seal system, and large amounts of gas escaping to the atmosphere, a backup seal is employed. Refer to Figure 9.1.10 which shows a triple dry gas tandem seal. For present designs up to 17,250 kPa (2500 psi), double tandem seals are proven and used.

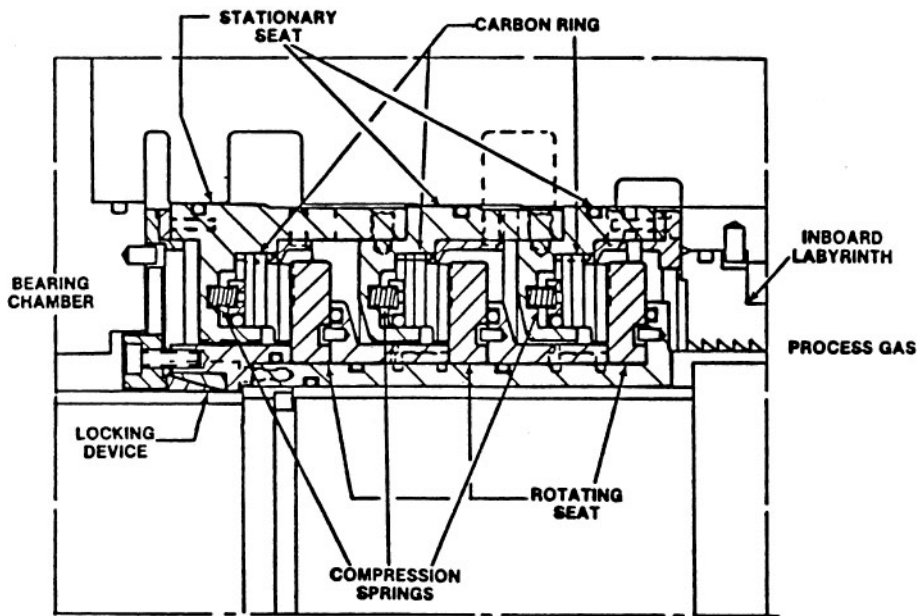

Figure 9.1.10 Dry gas seal: a triple tandem dry gas seal arrangement (Courtesy of Dresser-Rand Corp.)

The arrangement is essentially the same as low/medium pressure applications except that a backup seal is used in place of the disaster bushing. Most designs still incorporate a disaster bushing between the backup seal and the bearing cavity known these days as the barrier seal. Attention in this design must be given to control of the inter-stage pressure between the primary and backup seal. Experience has shown that low differentials across the backup seal can significantly decrease its life. As in the case of liquid seals, a minimum pressure in the cavity between the seals of 172-207 kPa (25–30 psi) is usually specified. This is achieved by properly sizing the orifice in the vent or reference line back to the suction to assure this pressure is maintained. All instrumentation and filtration are identical to that of the previous system.

Dual seal and system options for toxic and/or flammable gas applications

There are many field proven options available today for use in toxic and/or flammable gas applications. In this section we will discuss the following systems:

- Tandem seals for dry gas applications
- Tandem seals for saturated gas applications
- Tandem seals with interstage labyrinth and nitrogen separation gas
- Double seal system for dry gas or saturated gas applications

Tandem seals for dry gas applications

The tandem seal arrangement for this application is shown in Figure 9.1.11 and a schematic of this seal in the compressor seal housing is shown in Figure 9.1.12. Gas from the compressor discharge enters the port closest to the compressor labyrinth end) and the majority of the gas enters the compressor thru this labyrinth. To assure that process

gas, which is not treated by the dry gas system, does not enter the seal chamber, (velocities across the labyrinth should be maintained between 6-15 m/sec (20–50 ft/sec). It is the writer's experience that considering labyrinth wear, the design should be closer to 15m/sec (50 ft/sec).

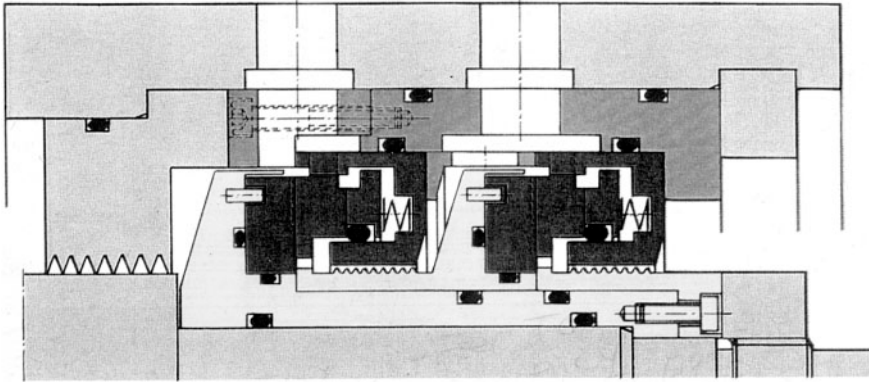

Figure 9.1.11 Tandem seal (Courtesy of Flowserve Corp.)

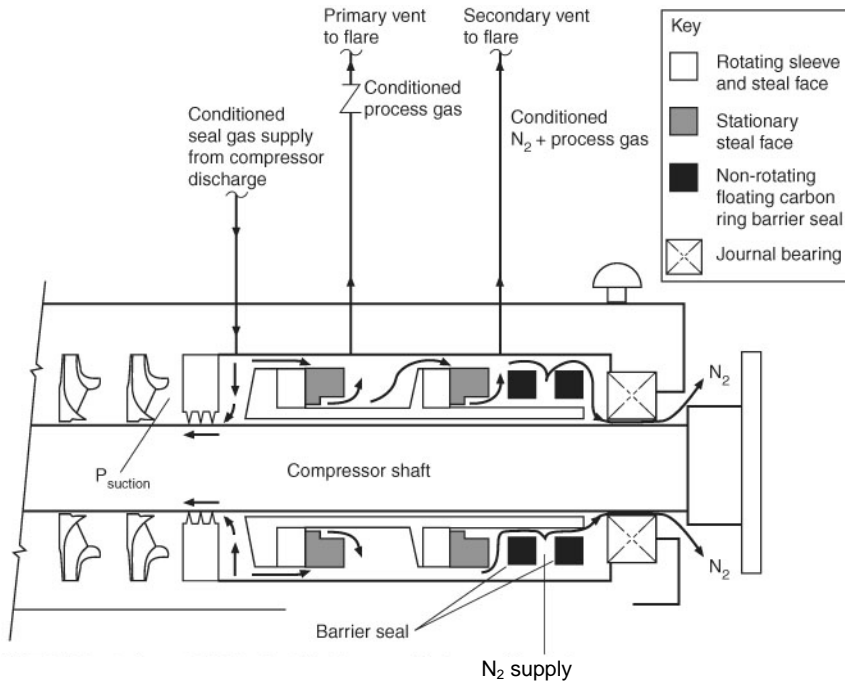

Figure 9.1.12 Tandem seal and barrier seal typical housing arrangement

Approximately 1.7-3.4 Nm³/hr (1-2 SCFM) flow (standard cubic feet per minute) leak across the first tandem seal faces (primary seal) and exit through the primary vent. Based on the backpressure of the primary vent system, 1.7 Nm³/hr (1 SCFM) or less will pass through the second tandem seal faces (secondary seal) and exit through the secondary vent. To assure that oil mist from the bearing housing does not enter the dry gas seal chamber and that seal gas does not escape to atmosphere, an additional barrier seal is used and provided with pressurized nitrogen at approximately 35 kPa (5 psi).

A typical seal system for this arrangement is shown in Figure 9.1.13. As previously mentioned, dry gas seal reliability depends on the condition of the gas entering the seal faces. The function of the seal gas supply system for any dry gas seal option is to continuously supply clean, dry gas to the seal faces. During start-up, when the compressor is not operating with sufficient pressure to supply the seals, an alternate source of gas or a gas pressure booster system should be provided. These items are shown in Figure 9.1.13 and are typical for any type of dry gas seal application. Note that the following options exist regarding the primary, secondary vent and barrier seal instrumentation and components:

- Primary seal vent triple redundant (2 of 3 voting) flow or differential pressure alarm and shutdown
- Primary seal vent rupture discs in parallel with vent line to rupture at a set pressure and prevent excessive pressure to the secondary seal on primary seal failure
- Spring loaded exercise valves in the primary vent line to exert a backpressure on the primary seal to close the faces in the event of dynamic 'O' ring hang-up
- Secondary vent line flow or differential pressure alarms and trips
- Barrier seal supply pressure alarm and permissive not to start the lube oil system until barrier seal minimum pressure is established.

Tandem seals for saturated gas applications

The tandem seal arrangement for this application can be exactly the same as that shown in Figures 9.1.11 and 9.1.12 for the dry gas application. The changes required for a saturated gas are solely in the seal system. A typical system is shown in Figure 9.1.14 and incorporates a cooler, separator and heater in addition to the normal components used for a dry gas application to assure that saturated gas does not enter the seal chamber. Typical values for the cooler are to reduce the gas temperature to 30°F below the saturation temperature of the gas. The typical dimensions for the separator vessel, complete with a demister, are 460mm (18 inches) diameter and 1.8 meters (6 feet) high. The typical requirements for the heater are to reheat the gas to 15°C (30°F) above the saturation temperature. Temperature transmitters are provided upstream and downstream of the cooler and downstream of the heater. As a precaution, in the event of cooler or heater malfunction, a dual filter/coalescer, complete with a drain back to the suction is provided.

Tandem seals with interstage labyrinth

The present (2010) industry 'best practice' tandem seal arrangement for dry or saturated gas applications is shown in Figure 9.1.15. This arrangement features a labyrinth between the primary and secondary seals. This action assures that gas vented from the secondary seal will always be nitrogen since the nitrogen supplied between the primary and secondary seals is differential pressure controlled to always be at a higher pressure than the primary seal vent thus assuring that only nitrogen will be in the chamber between the primary and secondary seals. Figure 9.1.16 shows a typical nitrogen supply system used with this tandem seal configuration.

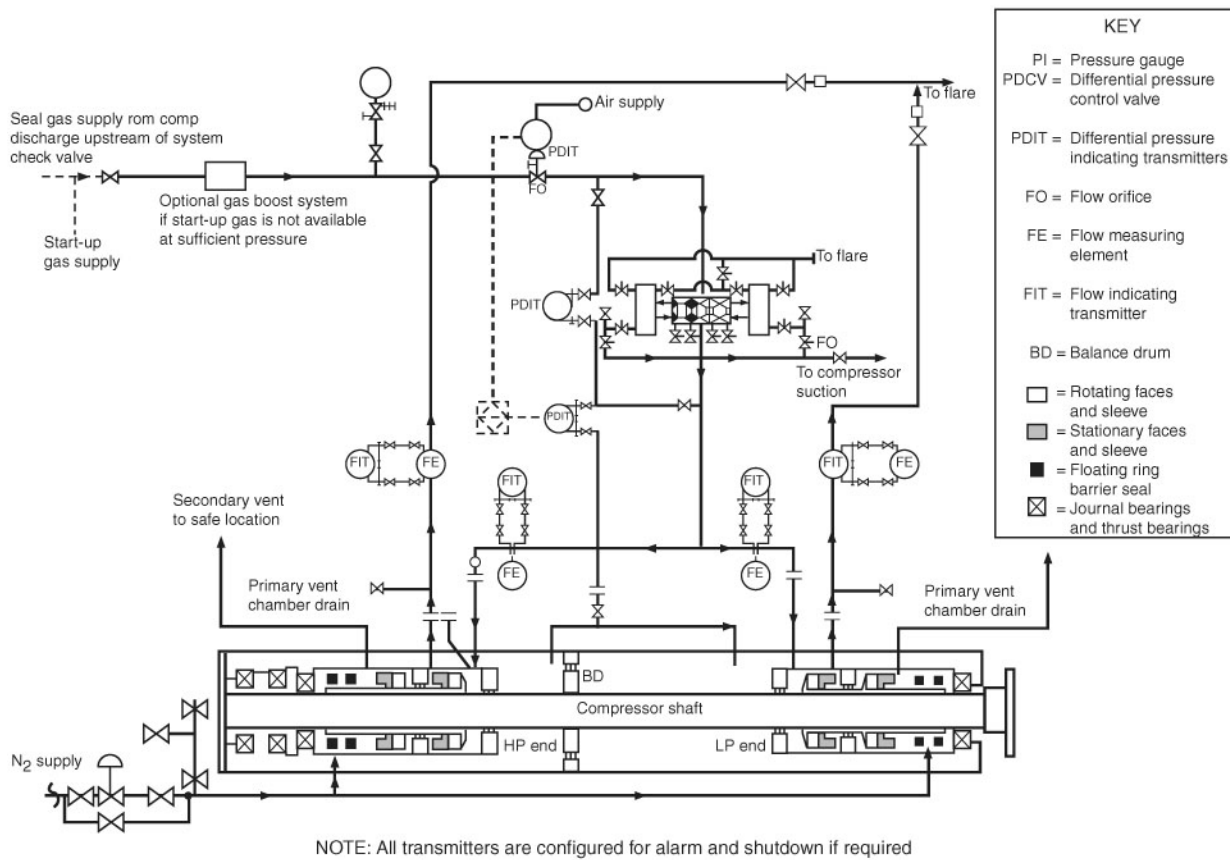

Figure 9.1.13 Typical tandem seal system for saturated process gas

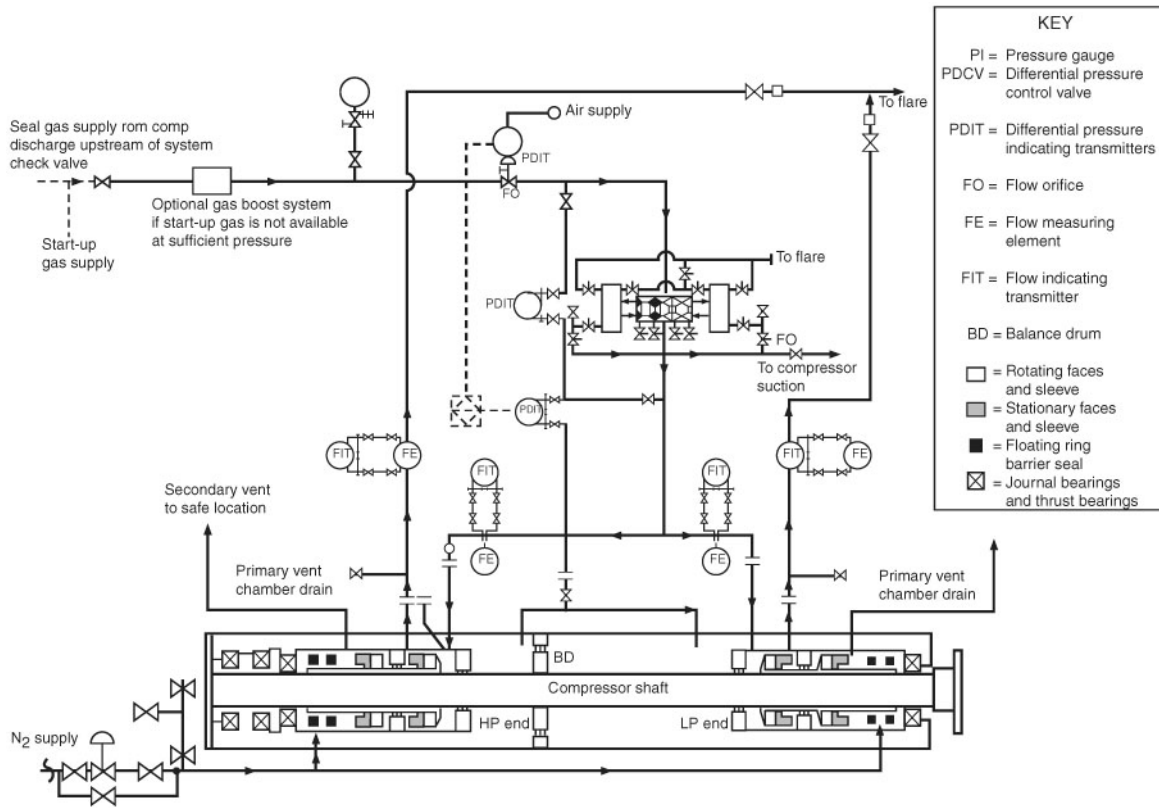

Figure 9.1.14 Typical tandem seal system for dry process gas

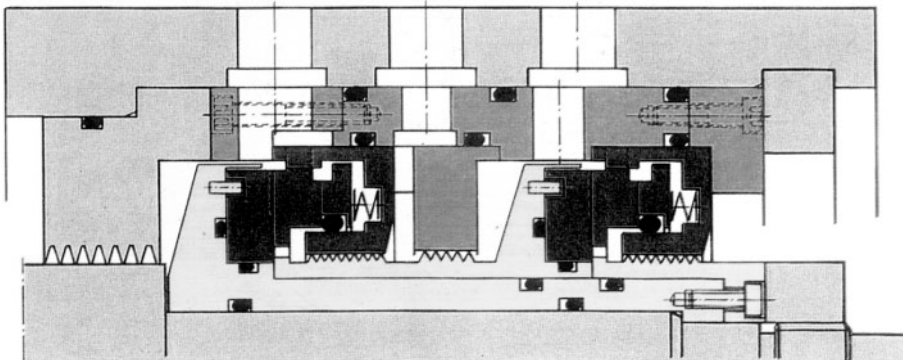

Figure 9.1.15 Tandem seal with interstage labyrinth (Courtesy of Flowserve Corp.)

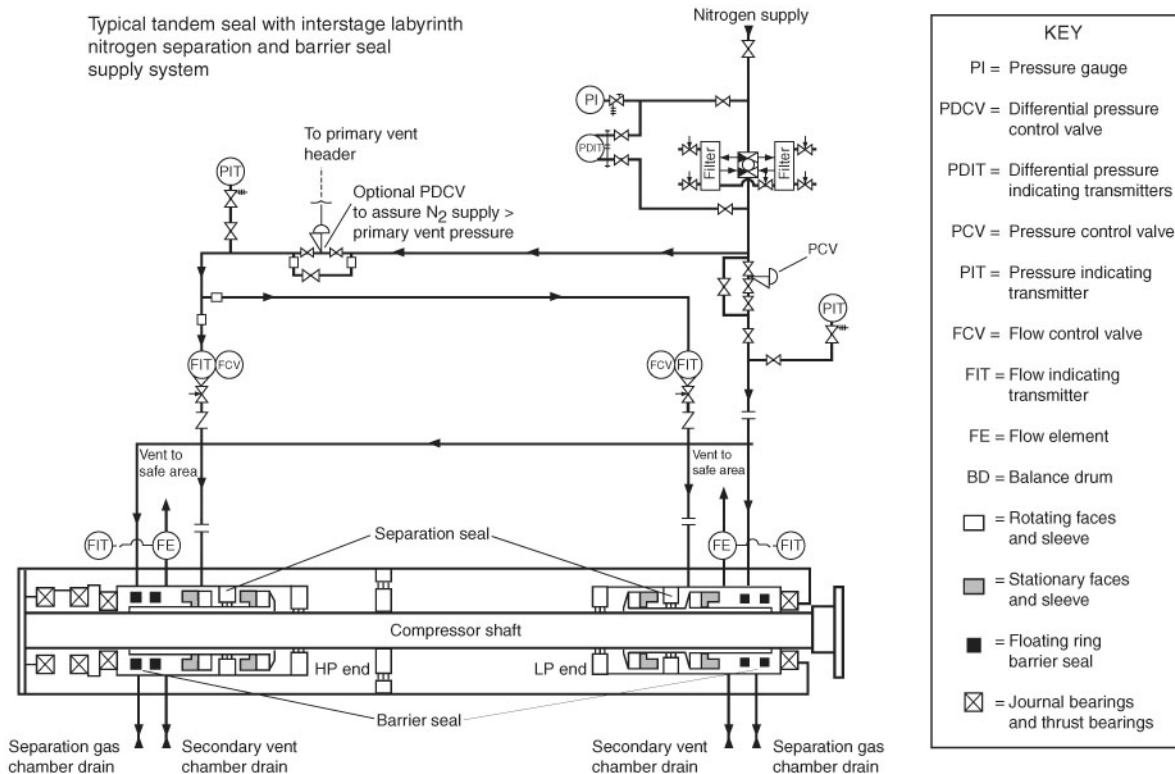

Figure 9.1.16 Typical tandem seal system with an interstage labyrinth-nitrogen supply

Double seal system for dry gas or saturated gas application

Figure 9.1.17 depicts a double seal used in either dry gas or saturated gas applications where the process gas is not permitted to exit the compressor case. For this application process gas can be used, after it is conditioned, or an external source can be used if it is compatible with the process gas. If the gas used between the seals is toxic or flammable, a suitable barrier seal, provided with nitrogen, as shown in Figure 9.1.12 must be used. The seal systems previously shown will be used for the supply of conditioned gas to the seals as required by the condition of the seal gas (dry or saturated).

Summary

Since there are significant advantages to the use of dry gas seals, many units are being retrofitted in the field which incorporates this system. In many cases, significant payouts can be realized.

If a unit is to be retrofitted, it is strongly recommended that the design of the gas seal be thoroughly audited to assure safety and reliability. As mentioned in this section, retrofitting from a liquid to a gas seal system renders the unit a separate system type unit, that is, a separate lube and gas seal system. Naturally, loss of lube oil into the seal system will result in significant costs and could result in seal damage or failure by accumulating debris between the seal rotating and the stationary faces. The adequate design of the separation barriers between the lube and seal face must be thoroughly examined and audited to assure reliable and safe operation of this system. Many unscheduled field shutdowns and

safety situations have resulted from the improper design of the lube system, seal system separation labyrinth. In addition to the above considerations, a critical speed analysis, rotor response and stability analysis (if the operating discharge pressure is above 3,450 kPa (500 psi) should always be conducted when retrofitting from liquid to dry gas seals.

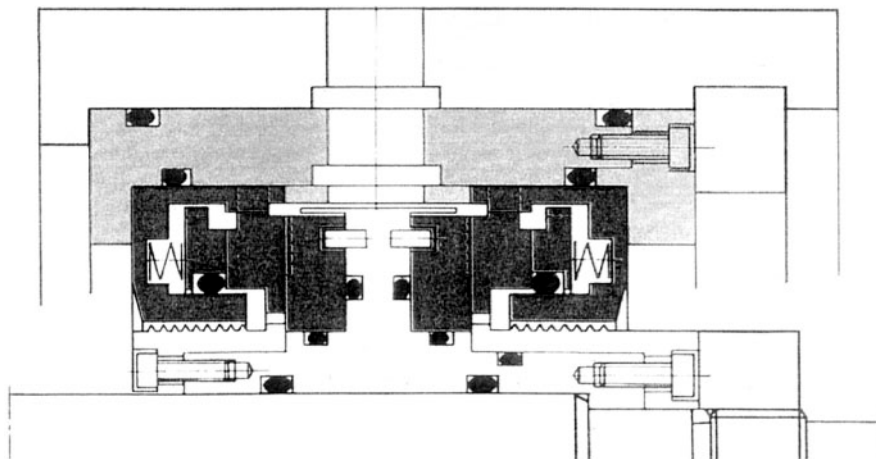

Figure 9.1.17 Double seal (Courtesy of Flowserve Corp.)

B.P. 11.7: Continuously monitor all dynamic equipment performance (Pumps, Compressors, Steam and Gas Turbines) to prevent component failures and to optimize component MTBF's, unit safety & reliability.

Approximately 80% of machinery component failures are related to process condition changes.

Failure to monitor, calculate and trend machinery performance (Efficiency, Flow Rate, Head, and Power) will lead to false root cause analysis conclusions and reduced component MTBF's.

Programs are available for all machinery types to download measured performance parameters (Pressures, Temperatures, Flows and Power), perform required calculations and trend Efficiency, Flow, Head and Power to determine:

- If operating condition changes are possible to optimize machinery performance
- If machinery internal inspection is required and the predicted maintenance requirements
- If machinery maintenance can be extended to the next turnaround

L.L: Failure to trend machinery operating points and performance indicators reduces machinery safety and reliability

As previously stated 80% of component failure root causes lie in the effects of the process.

Failure to integrate the machinery operating point and internal performance to mechanical effects (Vibration, Temperature etc.) impact component MTBF by not identifying the root causes of the reliability issues.

BENCHMARKS:

The writer has used this best practice since 1984 while being involved with the start-up of a large petrochemical complex to identify pump operation outside the EROE (See B.P: 2.7) and compressor and steam turbine internal fouling issues for on-line cleaning without the necessity of shut downs.

SUPPORTING MATERIAL:

Refer to the following Best Practices for supporting material concerning performance monitoring & Trending:

- Pumps -----B.P: 2.7
- Compressors-----B.P: 3.14, 3.17 & 3.27

- Steam Turbines -----B.P: 5.4 & 5.13
- Gas Turbines -----B.P: 6.9 & 6.10