

Walking Speed detection from 5G Prototype System

Bahareh Gholampooryazdi

School of Electrical Engineering

Thesis submitted for examination for the degree of Master of
Science in Technology.

Espoo 22.5.2017

Thesis supervisor and advisor:

Prof. Stephan Sigg

Author: Bahareh Gholampooryazdi

Title: Walking Speed detection from 5G Prototype System

Date: 22.5.2017

Language: English

Number of pages: 6+63

Department of Communication and Networking

Professorship:

Supervisor and advisor: Prof. Stephan Sigg

While most RF-sensing approaches proposed in the literature rely on short-distance indoor point-to-point instrumentation, actual large-scale installation of RF sensing suggests the use of ubiquitously available cellular systems. In particular, the 5th generation of the wireless communication standard (5G) is envisioned as a universal communication means also for Internet of Things devices.

This thesis presents an investigation of device-free environmental perception capabilities in a 5G prototype system in two cases; walking speed and human presence detection, and elaborate a comparison with the former case and acceleration sensing analysis. This thesis attempts to analyze the perception capabilities of 5G system in order to recognize human mostly common activities and presence detection near transceiver devices which the instrumentation exploits a device-free system capable of detect activities without carrying devices capitalizing on environmental RF-noise. This is done via the study of existing and related literature. After that, the implementation and evaluation of walking speed and presence detection is described in details. In addition, evaluation consists of utilizing a prototypical 5G system with 52 OFDM carriers over 12.48 MHz bandwidth at 3.45 GHz, which we consider the impact of the number and choice of channels and compare the recognition performance with acceleration-based sensing. It was concluded that in realistic settings with five subjects, accurate recognition of activities and environmental situations can be a reliable implicit service of future 5G installations.

Keywords: walking speed; ambulatory; presence detection; OFDM waveforms
; acceleration; 5G network

Acknowledgements

I would like to express my appreciation to Dr. Stephan Sigg. Thanks for giving me the opportunity to be part of the Ambient Intelligence Group and guiding me wisely with the great thoughts and providing great helps during the whole process with the data, experiments, and the great ideas and also your patience and understanding. I could never make it without your help.

My gratitude also goes to the Comnet Lab. Viktor Nässi, Kalle Ruttik, Jussi Kertulla, thank you for the help with the experiments, setups, the advice and the ideas. It is an honor to work with you. Besides, I would like to thank Ambient Intelligent group members especially, Le Ngu Nguyen and Muneeba Raja for all their kindness, guidance and great supports.

The most special thanks goes to my boyfriend and best friend, Navid Shamsizadeh. You have always been there supporting and encouraging me, You have enlightened my life. Thank you.

Otaniemi, 22.5.2017

Bahareh Gholampooryazdi

Contents

Abstract	ii
Acknowledgements	iii
Contents	iv
Abbreviations	vi
1 Introduction	1
1.1 Research Methods	1
1.2 Structure of Thesis	2
2 Background	3
2.1 Activity Detection from RF	3
2.1.1 RSSI based	4
2.1.2 Specialized Hardware Based	6
2.1.3 Radar Based	8
2.1.4 CSI Based	9
2.2 Presence Detection	10
2.3 Acceleration Sensing	11
2.3.1 Sensor Specification	12
2.3.2 Attachment Location	13
2.4 Activities and Features Selection	14
2.5 OFDM and 5G System Characteristics	18
2.5.1 Key Requirements for RF Interfaces of 5G	18
2.5.2 5G Sub-Frame Structure	19
2.5.3 5G Waveform Selection	20
2.5.4 OFDM Overview	21
2.5.5 OFDM Enhancements for 5G	22
2.6 Conclusions	24
3 Walking Speed Recognition	25
3.1 Motivation	25
3.2 Research Methodology	25
3.3 System Description	25
3.4 Experimental Procedure	26
3.5 Data Collection	28
3.5.1 RF Data	28
3.5.2 Acceleration Data	28
3.6 Data process	28
3.6.1 Frequency Domain Analysis	28
3.6.2 Feature Extraction	31
3.6.3 Windowing Mechanism	31
3.7 Data Analysis	33

3.7.1	Classification	33
3.8	Conclusion	33
4	Presence Detection	35
4.1	Motivation	35
4.2	Research Methodology	35
4.3	System Description	35
4.4	Experimental Procedure	35
4.5	Data Collection	37
4.6	Data Process	38
4.6.1	Feature Extraction	38
4.6.2	Sliding Window Mechanism	38
4.7	Data Analysis	38
4.8	Conclusion	39
5	Results	40
5.1	Walking Speed Detection	40
5.2	Presence Detection	41
6	Conclusion	46
	References	47
A	Appendix	54
A.1	Classification Learner application in MATLAB	54
A.1.1	Train Classification Models	54
A.1.2	Choose Validation Scheme	54
A.1.3	Compare and Improve Classification Models	57
A.1.4	Export Classification Model to Predict New Data	57
A.2	k-Nearest Neighbors Algorithm	59
A.3	Cross Validation	59
A.4	USRP, Software Defined Radio Device	62
A.4.1	USRP X310	62

Abbreviations

Abbreviations

RF	Radio Frequency
5G	5th Generation
USRP	Universal Software Radio Peripheral
OFDM	Orthogonal Frequency Division Multiplexing
RSSI	Received Signal Strength Indicator
CSI	Channel State Information
DfP	Device-Free Passive
DFAR	Device-Free Activity Recognition
FMCW	Frequency Modulated Carrier Wave
UWB	Ultra-Wideband
NICs	Network Interface Cards
FD	Dall Detection
AP	Access Point
MP	Monitoring Point
PHY	Physical Layer
MEMs	Microelectromechanical Systems
IMU	Inertial Measurement Units
FFT	Fast Fourier Transform
DFT	Discrete Fourier Transform
DWT	Discrete Wavelet Transform
NR	New Radio
TR	Technical Report
3GPP	Third Generation Partnership Project
TTI	Transmission Time Interval
URLLC	Ultra Reliable Low Latency Communication
SF	Sub-Frame
FDD	Frequency Division Duplex
TDD	Time Division Duplex
SINR	Signal-to-Interference-Plus-Noise Ratio
SQNR	Signal-to-Quantization Noise Ratio
CDF	Cumulative Distribution Function
MIMO	Multiple-In-Multiple-out
OCI	Other-Cell Interference
DMRS	DeModulation Reference Signal
LTE	Long Term Evolution
LTE-A	Long Term Evolution Advanced
RAT	Remote Access Trojan
CP	Cyclic Prefix
ISI	Inter-symbol Interference
ZP-OFDM	Zero Padding Orthogonal Frequency Division Multiplexing
PAPR	Peak-to-Average Power Ratio
ADC	Analog-Digital Convertor
DAC	Digital-Analog Convertor
Tx	Transmitter
Rx	Receiver
KNN	K-Nearest-Neighbors algorithm
WiFi	Wireless Fidelity
BPS	barometric pressure sensors

1 Introduction

5G cellular networks are assumed to be the key enabler and infrastructure provider in the ICT industry and the backbone of IoT [1]. The shared access of 5G systems to the wireless channel and communication envisions environmental perception [2, 3, 4]. However, unlike classical RF-sensing approaches that exploit WiFi, the distance between transceivers is hugely larger in cellular systems. 5G technology will revolutionize ubiquitous and pervasive sensing by providing a significantly larger number of devices to generate RF-traffic and will operate at higher frequency and larger bandwidth [6]. It in fact aims to create a complex and advanced scenarios of heterogeneous networks, enable to provide vast majority of ubiquitous perception services [63]. One of the key challenges of upcoming 5G technologies is implementation of accurate and reliable channel models to aid optimization systems accounting for practical operating conditions [63].

Recognition of environmental perception especially utilizing radio frequency fluctuations has become undemanding [3]. In fact, human movement and existence in adjacent of radio signal can influence the radio strength and change the communication patterns on received signal. Then radio based activity recognition is accomplished by irregularities in signal pattern caused by channel characteristics and body fluctuations [62]. Human activity recognition may be accomplished with various modalities listed as received signal strength, channel state based detection, recognition by software defined radio devices, perception via radar, wearable sensors and etc. .

The main factor in common of the beginning four groups is that they have device-free mechanism which means that it is non sensor-based and do not need any extra carried device or sensor to detect activities and they exploit radio frequency fluctuations.

1.1 Research Methods

During this thesis, we analyze walking speed and presence detection from a 5G prototype system which was employed in Communications and Networking Lab. in Aalto University. Then, we conduct three different case studies by collecting data from RF for two purpose of walking speed and human presence detection and evaluating data from accelerometer to compare with RF walking speed data. To support the theoretical part, technical actual experiments are carried out with different scenarios and 5G waveform (enhanced OFDM) as data transmission over 12.48 MHz bandwidth at 3.45 GHz. In the course of our testing, we evaluated the impact of various combinations of OFDM carriers which we select different number of them to achieve better accuracy. This thesis uses many signal processing and machine learning techniques and algorithms with a realistic setting in order to approach reliable recognition accuracy which will be utilized for environmental perception for upcoming 5G technology.

1.2 Structure of Thesis

This thesis is divided into six chapters including this introductory chapter. In chapter 2, we discuss about the literature review of the work done in related area. Chapter 3 will represents the required steps for walking speed recognition including data collection we obtained from both 5G system and acceleration data and data process step covering the filtering methods and sliding mechanism applied on the data to make it suitable for classification analysis. After implementation, section 3.7 will be defining the validation process of the Walking-Speed case. Chapter 4, will focus on presence detection scenario with detail information about system characteristics and data process. In the continuity of the validation part, chapter 5 will focus on the usability of the implemented solution and achieved results. Finally, in the last chapter 6, we will summarize the thesis, and discuss about the next steps relative to the topic.

2 Background

This chapter gives a literature review of the previous experiments and studies regarding human activity recognition using different sensing devices and data analysis. First we explain experiments used RF sensing devices and device-free presence detection techniques exploited in different studies with various categories. Secondly we describe acceleration sensing for motion detection. In next section, we focus on detail information about different features selection and applied machine learning algorithms used for data classification. Eventually, we describe characteristics of proposed 5G system which include OFDM for data transmission in detail in the later chapter.

2.1 Activity Detection from RF

The device-free approach identifying as a technique which can detect fluctuations caused by human movements without wearing devices or sensors is recently becoming popular. Systems based on device-free recognition works by monitoring and processing changes in the received physical signals. Device-free systems utilize radio frequency (RF) signals to transport information through air from transmitter antenna to receiver antenna. The propagation of RF signals has amplitude, frequency, and phase which the first one indicates strength of the RF signal [59].

Device-free sensing methods has many benefits comparing with traditional approaches like sensor and device attached techniques. One of the main advantages is having less cost due to using only radio with embedded signal strength measurement tools with no additional sensing hardware. Moreover, it provides deep knowledge of wireless links and transmission channels and leads to beneficial exploitation of physical and environmental phenomena for detecting human movements and activities. In addition, the power consumption depends on transmission rate and application; Although the device-free sensing approach may not replace actual sensors, the addition of information achieved from RF phenomena (will be explained in following paragraph) like fading-induced information which employ many benefits in a sense of pervasive applications [9].

In fact, they are two main phenomena called fading and shadowing which are caused radio frequency transmission. They affect mostly amplitude and power of the signal in the receive side which can have both useful or destructive impacts on signal strength. They can increase RF signal potentiality by affecting its strength [9].

When the receiver receives multiple sub-divisions of signal propagating from transmitter which every division take separate path, multipath effect happens. It will take different time for each sub division to reach to transmitter because of various distances due to bouncing with obstacles [60]. Moreover, multipath leads to another fact called fading. When RF signals encounters propagation media (various paths), distortion of a transmitted carrier-modulated RF signal occurs which is sometimes referred to as multipath induced fading [60]. Fading conducts another phenomenon which is shadow fading. Shadowing is the effect that the received signal power fluctuates due to objects obstructing the propagation path and penetration of

obstacles between transmitter and receiver [61].

Consequently, RF signal analysis can take advantages of fading and shadowing. Multipath allows radio waves effectively to go through obstacles by getting around them, thereby increasing the radio coverage area occurs. Moreover, by proper processing of the multipath signals, with smart or adaptive antennas, the exploitation of received power can be increased [9]. The constructively advantages of RF signals capabilities can lead to effective motion and activity detection from signal fluctuations [9]. The radio signals could be used to capture the variation in the environment especially caused by human movements as the human body can scatter or reflect RF propagation causes fluctuations of a signal at the receiver. More technically, human body have impacts on signal strength (amplitude) changes in neighborhood of RF signals with different frequencies employed. There have been many studies employing RF signals to track and detect human activities and movements. Device-free human detection systems can play a critical role for emerging internet of things (IoT) services such as smart spaces, human-computer interaction, smart health monitoring systems and asset security [8].

Based on [7], existing work on device-free human activity recognition and localization from RF signal fluctuations can be divided into four main categories: Received Signal Strength Indicator (RSSI) based, specialized hardware based, radar based, and CSI based [7]. The first one indicates received signal strength indicator (RSSI) which is a measurement of the power present in a received radio signal. The next one is exploitation of hardware devices as transceivers for data transmission and analysis. In addition, conducting radar technology can lead to an effective way of motion detection and the last one which is utilizing channel state information of transmitted signals in order to detect and track motions and activities and extract useful information from channels [7].

2.1.1 RSSI based

RSSI can be obtained from MAC layer in ZigBee, WiFi and other wireless technologies and it is a useful tool to measure the relative quality of a received signal. Hence it is an indicator of power level that the RF signal is receiving from transmitter. With the observation that different human activities result in various wireless communication patterns between transmitter and receiver, we can extract RSSI values to analyze signal [7, 18]. There have been an investigation on RSSI value exploitation for human activity recognition systems take advantages of signal strength fluctuations coming from human movements [10, 11, 4].

Authors in [12] proposed a device-free activity recognition approach based on RSSI values but in network layer (recieveing packet with link state information) which includes information about channel. According to [12], they can classify the moving direction, moving state, and moving velocity based on the metrics of link state information (packet delivery ratio and time intervals) [12].

According to studies, there are several challenges on RSSI investigation for activity recognition comparing with other methods. Authors in [14] claimed that these challenges include dealing with signal propagation issue due to multipath

interference, medium access control and various noises in wireless links; examination of different gestures, activities and their entities from various humans and also solving the problem of noisy fluctuations of signal due to interference of other people in vicinity of transceivers and finally exploiting energy efficient methods and techniques in favor of mobile communication devices [14]. In the other hand; according to [10], the exploitation of frequency domain features from RSSI based activity recognition is critical due to the noisy channel of data transmission and low accuracy of RSSI values [10]. In particular, RSSI is sensitive to RF signal propagation effects.

Besides the challenges, there has been successful evaluations on RSSI-based detection including [10, 13, 14]. In [10], they have evaluated many scenarios including a comparison of active and passive continuous signal based as well as active RSSI-based Device-free activity recognition (DFAR) system regarding the recognition of simple activities, walking speeds, localization of conducted activities [10]. Notably, active DFAR systems exploits transmitter device for detection in contrast with passive DFAR which incorporates only ambient signals. Furthermore, they evaluated the results for both active and passive continuous signal-based DFAR. The former one refers to a signals modulated into wireless carrier and the latter one indicates feature-based information extracting from Received Signal Strength Indicator (RSSI) [10]. The authors achieved comparable accuracies by investigation on various scenarios besides all RF signal propagation challenges. They showed that active continuous signal-based DFAR is potentially the easiest case for RF-based DFAR [10].

According to [13], device-free activity and presence recognition can be obtained from received RSSI values which is measured in receiver side by deploying all sub carriers of received signal which has taken various paths to reach transmitter. Based on their study, the system has the potential of sensing the presence of subjects in adjacent of transceivers (mobile phone), Figure 1. The authors claimed two main benefit of the utilized system, first the capability of operating with no need of carrying the device and operation in dark environments which no dependence on using camera or other visual and audio sensors [13].

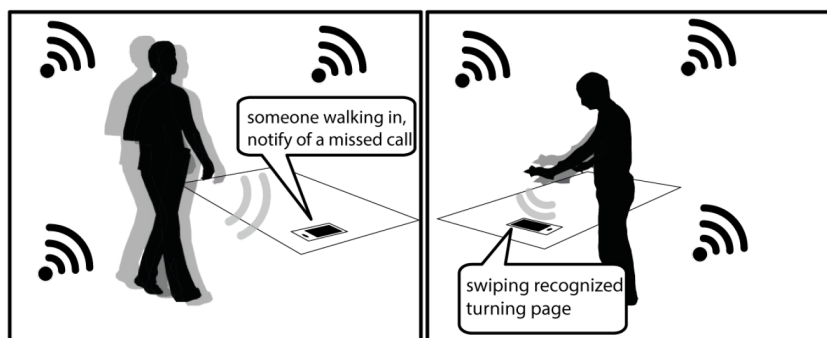

Figure 1: The figure indicates two different scenarios utilized to extract RSSI values: user walks in vicinity of smart phone with no interaction with device (left) and the subject walks and employ smart phone as well (right) [13].

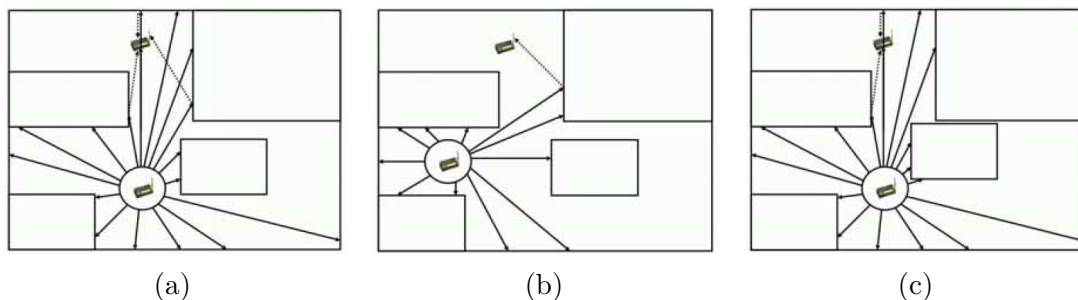

Figure 2: The figure shows three different multipath effects occurs during experiments. The (a) shows two transceivers (transmitter and receiver) locating in front of each other in an indoor environment with reflected paths. (b) indicates the different situation which transmitter location is changed while data transmission includes obstacles leads to multipath transmission and (c) reveals the use case when the place of an obstacle is changed and it got closer to transmitter in the right side. The lines represented paths, arrows identify radio signal propagation through wireless link; and dashed lines show sample reflected paths [9].

They are two main channel characteristics (multipath fading and shadowing) which can be utilized on wireless links for activity detection and recognition. Authors have shown these concepts by an example employed on their experiments (see Figure 2). Based on the study, they considered three main scenarios including : transceivers placing in line-of-sight of each other, placement of transmitter with obstacles and obstacle location change to be closer to transmitter.

(Figure 2 (a)), reveals the case which fluctuations of signal is changed duo to both noise and attenuation from environment (placing many obstacles) and motion of transceivers which the former one leads to more impairment on received signal and the latter one causes small scale fading which have continuous impacts on all the paths traversed by signal. For this scenario, a densely indoor environment is utilized. Figure 2 (b) reveals the second scenario which the transmitter is placed in non-line-of sight of receiver with obstacles during transmission paths which cause fading of the received signal. They are again two different fading impacts occur. The first one relate to movement in vicinity of transceivers which has smaller fading effect compared to second fading impact which is placement and movements of subject through line-of-sight of paths which leads to fading in a larger scale. The reason for small values in RSSI from transceiver fading is the fact that not all paths would be effected by fading and it only affects some of them. Fig. 2 (c) indicates the third case when the placement of one obstacle is changed and the impacts on received signal strength because of bounding one of the reflected paths [9].

2.1.2 Specialized Hardware Based

Software defined radio devices can be exploited to collect fine-grained radio signals [15, 16, 17, 3]. Authors in [73] claimed that fine-grained radio frequency channels are more effective and efficient because, it will provide the accessibility of dividing the

channel into smaller sub-channels and allocate different nodes to access different sub-channels simultaneously. Many studies suggested various software defined radio devices which among them Universal Software Radio Peripheral (USRP) is one of the most popular one used for detection and can investigate on device-free motion offs extra hardware [18]. Human activities can be recognized by monitoring changes in wireless (e.g., WiFi) signals in which WiFi based human activity recognition systems are capable of building patterns which enable them to recognize relative motions and activities [3]. Pu et al. [3] claimed that the system (WiSee) can recognize nine body gestures connecting to home WiFi interacting with devices by influencing the Doppler shift of wireless signals. WiSee is a gesture recognition system, which can detect activities, occur in homes employing wireless signals since they are capable of passing walls and are non-line-of-sight. They have investigated on six scenarios (see Figure 3). Based on the paper, they have extracted a rich set of gesture information from wireless signals using only two wireless sources (simple WiFi routers) with a high accuracy of 95%; however, their approach is non-localization because they do not have no mechanism for obtaining location of a person and the system can only detect the presence of humans or recognize gestures and activities [3].

In paper [18], the authors presented a device-free WiFi-based gesture recognition system (WiGeR) using WiFi router (TP-LINK TL-WR842N) by leveraging the fluctuations in the channel state information (CSI) of WiFi signals caused by hand motions. Based on [18], they employed high throughput antennas in transmitter hardware (the WiFi router) in order to improve efficiency and accuracy of hand motion detection through multiple walls. In addition, they extracted CSI from any common WiFi router and then filter out the noise to obtain the CSI fluctuations caused by hand motions. Accordingly, they have extracted one single carrier from each 30 sub-carriers (they leveraged only amplitude of channel characteristics) because of OFDM mechanism and their implementation of a 2*3 MIMO. According to their study; however, WiFi-based gesture recognition systems lack security and are still limited in their sensing capabilities through multiple walls, they have presented their system capable of providing user security and device selection mechanisms. The authors also stated that beside SDR-based devices, which are costly and not secure enough, their mechanism requires only an access point (a WiFi router) which are simply available.

There has been a remarkable study on designing specific radio-frequency device for gesture recognition in [17]. The system is called AllSee which uses a specially designed analog circuit to extract the amplitude of the received signals to recognize gestures [17]. According to study, AllSee has three main characteristics. Firstly, it operates on battery-free devices, which make the mechanism energy efficient. Secondly, it can enable gesture recognition constantly on mobile devices and finally, it provides small form-factor consumer electronics without the need for input hardware like keypad [17].

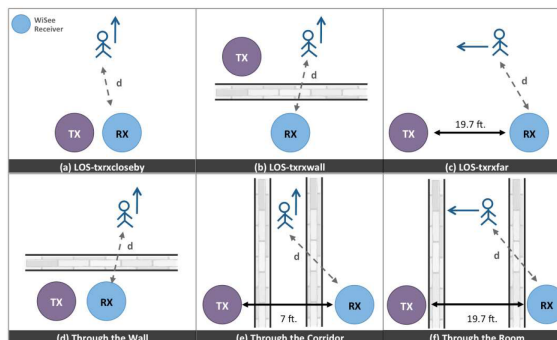

Figure 3: WiSee gesture recognition scenario [3].

2.1.3 Radar Based

Radio detection and ranging (radar) is a wideband used for movements detection which can operate both in ultra-high-frequency (UHF) or microwave part of the radio-frequency (RF) [88]. Even though, human activity can be recognized from different type of sensors and devices as we mentioned before (e. g. wearable sensors, SDR devices and etc.), authors in [74] claimed that, radar-based activity recognition privileges other approaches. Firstly, it can operate in a dark environment which key characteristics of signals which can be obtained without utilizing visual devices like camera. Secondly, the privacy is preserved based. Moreover, it can be used for great distances and with multiple walls in the middle. Capability of recognizing more fine-grained activities or any faults on gait recognition causing by any impairments on activities is another advantage based on [74]. Moreover, authors in [24] stated that radar based detection can be really useful in circumstances with poor visibility.

Radar-based systems attain gait recognition by exploiting patterns from activities and movements in micro-Doppler performed for different activities. Based on [74] when a radar transmits an electromagnetic signal to a targeted subject, the fluctuations of signal will be changed and it returns back to the radar. Fluctuations in the properties of the received signal reflect the characteristics of subject. When the target moves with a constant speed, the carrier frequency of the returned signal will be shifted. This is known as the Doppler effect. Consequently, if the subject has other movements like vibration or rotation then it could generate sidebands on the returned signal, which is called Micro-Doppler effect.

[74] stated Micro-Doppler effects can be attained mostly from continuous wave (CW), frequency modulated continuous wave (FMCW) and pulse Doppler radar. The authors also claimed that one of the challenges of using radar-based systems is their sensitivity to frequency band of transmitted signal which in lower frequency bands, fluctuations might not be detectable which requires them to use high frequencies. WiTrack employed specially designed Frequency Modulated Carrier Wave (FMCW) signals to track human movements behind the walls with a resolution of approximately 20cm [19, 20]. According to [19], WiFi signals have much narrower bandwidth compared to the specially designed radar signals such as FMCW or Ultra-wideband (UWB) signals [19].

In fact, Micro-Doppler mechanism is frequency modulation about the central Doppler causing by fluctuations of some parts of subjects. These fluctuation can be vibration or rotation which occurs in mobility conditions of human (periodic motions) which leads to specific micro-doppler signature. They are two successfully studies [75, 76] that achieve high accuracy of 92% and 90% respectively by applying proper machine learning algorithms and pattern recognition techniques. The former study employed spectrum as input data (using Doppler features) to distinguish performed directly towards radar. The latter one utilized multistatic radar system for recognition which employ micro-Doppler features.

2.1.4 CSI Based

In OFDM scenario, each subcarrier is multiplied by a constant gain and OFDM technique simplifies the equalization process of all received subcarriers by using channel state information (CSI). CSI is used in MIMO transmission which include multiple antennas in transmitter and receiver, which channel carries the information of a matrix created MIMO transmission and knowledge about error rate refers to signal-to-noise-ratio. In wireless communication system, channels for data transmission have some specific characteristics which can be used in order to detect and identify signals achieving from different human movements. These extracted information from channels is called channel state information which is basically analysis of signal behavior while traverse the path between transceivers. The main measurements extracted from channels are amplitude and phase of every sub carrier [72]. There have been many studies exploiting CSI values in order to track and detect human activities [28, 32, 29, 27].

WiHear utilizes WiFi signals in order to detect spoken words while people talk. It extracts CSI values from lip movements and directional antennas are exploited to receive CSI fluctuations caused by lip motions [32]. E-eyes system is another mechanism utilizing both WiFi devices and CSI values in order to detect human activities. Authors in claimed that their system is capable of uniquely detecting walking movements occurs in home environment and indoor position of subjects by extracting fine grained CSI values (values extracted from various sub channels instead of single channel) [31].

There is a successful study using CSI mechanism in order to detect human activities. The system is called CARM (CSI-based human activity monitoring system). Based on the study, there is a significant change which makes CARM special and is converting CSI values collected from human motions to speed information by using a fact that they are various speeds specialized for each individual. The CARM operates in a way of collecting CSI values from human motions and investigate on finding the correlation between speed and movement based on Hidden Markov Model [30]. In addition, WiFall is another notable work exploiting CSI values for human detection. Their objectives based on the study includes two main phase. First, they extract amplitude and phase values from sub channels and then they apply machine-learning algorithms. Finally, they employ falling detection mechanism to distinguish falling

from other movements [23].

Figure 4 presents an overview of WiFall influences CSI to indicate human activities. The WiFall system consists of three main phases: sensing, learning, and alerting. In the sensing phase, the transmitter (Access Point, AP) sends the signals. The receiver (Monitoring Point, MP) collects the wireless physical information CSIs, and sends them to the next phase. Learning phase contains three important modules: data processing, profile construction, activity decision module. In the final phase, fall detection mechanism is operating in order to discriminate falling values from various movements [23].

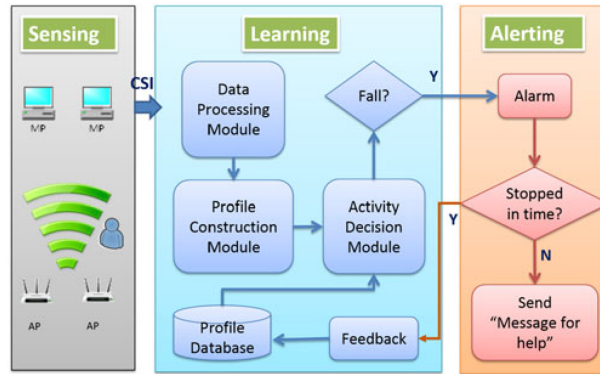

Figure 4: Overview of WiFall system architecture [23].

Comparing to RSSI recognition, CSI is more meaningful in a way that it is a fine-grained mechanism (allocation of smaller sub carriers in channel instead of a single carrier) from the physical layer consisting of amplitude and phase values of each sub carrier. In addition, sub carriers in CSI scenario can traverse in various paths while reaching to transmitter which cause sub carriers obtaining different amplitude and phase values. The other advantage of CSI utilization is collection of multiple CSI values at the same time [33].

2.2 Presence Detection

Signal fluctuations as we mentioned in previous section can take impacts of human presence and movements near to transmitter and receivers leveraging the fact that each person has a pattern of movement which can cause irregularities in signal being useful for detection. In order to quantify the information in terms of human presence, there have been different human presence detection methods. Authors in [34] suggested a novel method for presence detection based on information entropy (expected value (average) of the information contained in each message) extracted from a sequence of received signal strength samples based (RSSI) on radio frequency without modifying the original environment in contrast with other presence detection solutions which incorporate sensors for human detection [34]. There is another notable study, which exploits RF signals in order to recognize human presence neighboring transceiver devices based on anomaly detection of human presence which is finding

patterns in data that do not conform to expected behavior and are often refer to observations, exceptions and anomalies based on the utilized application [36].

According to [34], the main method which they conducted is based on Shannon information entropy [35] in order to quantify the information in terms of human presence from a set of principal components. The RSSI variation over multiple radio links is used as a basis for extraction of expected components. The process is in a way that the information entropy measures of the randomness. In a case of non-existence of any subject, the entropy of the radio signals values has a maximum value. Then the presence of a human reduces the value of expected received RSSI, within a lower entropy value [34].

Their proposed method includes home monitoring device and wireless nodes (smart power outlets and light switches). The controller device regularly checks the wireless nodes in order to collect RSSI values. When the wireless nodes achieve the request from control nodes, they send a message including RSSI values to other nodes in its vicinity. The request is received on the controller's input and by other nodes. Nodes accordingly will update their RSSI table with new received values. The operation is being terminated when all nodes finish sending their commands (RSSI values) to neighboring nodes [34].

In addition, there has been another method exploiting RF signals in order to recognize human presence neighboring transceiver devices [36]. The paper proposed an accurate technique for detecting human presence based on non-parametric statistical anomaly detection. In particular, authors considered an individual data instance as anomalous with respect to the rest of the data. Based on the article, the mechanism consists of some control units, which identify the signal strength characteristics in a case of no subject in the environment, and then they send the information to application servers in order to recognize any anomalies in the signal strength due to human motion activity. The monitoring points are updated to be able to capture all information from environment.

Figure 5 shows an overview of utilized method for presence detection employed in [36]. It shows the location of multiple transmitters and receivers placed in the environment. They are also monitoring nodes (MPs) and an application server which collects all the information from control units (MPs). The main operation is done by application server which utilized received data to deploy required detection tasks [36].

2.3 Acceleration Sensing

They have been many studies conducting worn sensors in order to identify, track and detect human activities. The acceleration sensing is mainly depends on two vital factors: the attachment location of sensor and selected activity [37]. Generally, the main factor of using accelerations is an increase of magnitude occurs on body from the head to the ankle [38]. Accelerometers are widely integrated into wearable systems in order to identify various activities. For instance, some studies used the Fitbit One and Actical accelerometers as a separate smart device for activity recognition [64] and some others employed mobile phones exploited acceleration sensing. Data from ubiquitous sensors play an important role in identifying activities

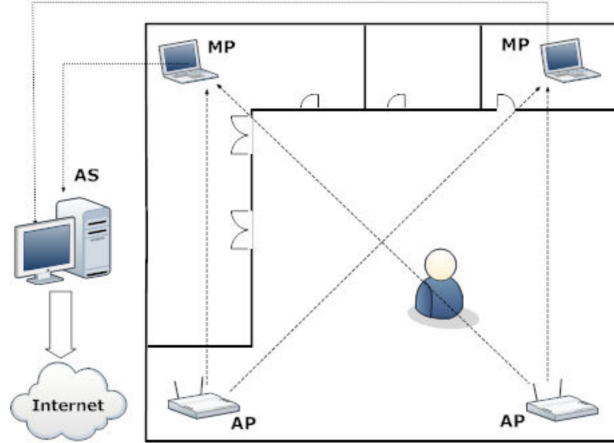

Figure 5: Typical device-free system for presence detection [36].

and employ required tools and methods to detect and track them. It has been shown that they are two main characteristics for acceleration sensing; sensor specification and attachment location, which should be obtained in order to get high accuracy and good recognition capabilities [39, 64].

There is a successful study for step analysis in walking speed from accelerometer data, which examined the effect of walking speed on the accuracy of an accelerometer-based monitor in ambulatory individuals poststroke and compared the effect of the position (waist versus ankle) on the accuracy of the monitor. In this study, it is shown that both location of accelerometer and sensor specification should be taken into considerations for accurate qualification. They employed a FitBit One device in order to collect data and they have also reviewed the effects of using different accelerometer devices. The authors claimed that the accelerometer position on the body that may affect the step count accuracy at slow walking speeds and an accelerometer can be improved for slower walking speeds when positioned at the ankle. Their findings suggest that the accelerometer is more accurate as walking speed increases from 0.3 to 0.9 m/s. In addition, the accelerometer is more accurate with ankle position on body, versus the waist, at the slower speeds (0.3- 0.6 m/s) [64].

2.3.1 Sensor Specification

There is an emerging trend of using smart devices to monitor health issues. Many researchers investigated on using accelerometer sensing capabilities in order to monitor acts and movements. These devices employ wireless sensors for collecting environmental data and devices utilize wireless communications protocols such as Bluetooth for data exchanges. The production of specific individual gait pattern for human activity recognition motivates many researchers to use small sensors like accelerometers to extract handful information for activity recognition capabilities. Many different types of devices have been used in recognizing various activities but it matters to select most suitable device in favor of related activity [65, 66]. For example, mobile phone motion sensors are an easy and popular way for activity recognition (mostly

used for ambulatory activities) by various placements on body [67, 68]. For the other type of wearable devices, wrist worn motion sensors are widely used which the acceleration and gyroscope sensors are embedded in a smart device with extra abilities like monitoring heartbeat or step counter and etc. [70].

For motion sensors, we can mention to accelerometer as the most popular one for activity recognition. Particularly, an accelerometer is an electromechanical device that will measure acceleration forces. These forces may be static, like the constant force of gravity pulling at feet, or they could be dynamic - caused by moving or vibrating the accelerometer. In addition, the other sensor, which assist acceleration sensing, is gyroscope, which measure angular velocity. Human body produces a cyclic motion with different partitions, which each partition repeats in every cycle. While using accelerometer and angular velocity, the cyclic pattern of human movements can affect the signature of extracted signals from aforementioned sensors [39].

There has been another study, which uses barometer combined with the accelerometer to recognize movements occurs using stairs: walking upstairs and downstairs. They employed barometric pressure sensors (BPS), which serves as an altimeter combined with a ReSense sensor, which incorporates a 6 degree-of-freedom inertial measurement unit (IMU). They claimed that using barometer causes the addition of the altitude information, which significantly increases the classification accuracy and leads to clear distinction between walking upstairs and downstairs [69].

2.3.2 Attachment Location

Different movements from body segments can be sensed by attached inertial sensors to body. The position of wearable motion sensors plays an important role in motion recognition. According to [69], they are two main categories of activities: simple and complex, which identify the suitable body location according to body movements. The former one indicates the daily activities that can be easily recognized like walking, biking, writing, sitting and standing. The latter one refers to activities which may include hand gestures; for instance, eating, smoking, drinking. Authors in [69] claimed that for complex activities additional sensor to accelerometer is also required because hand movements are also involved.

For a special case of walking speed, a vast majority of inertial sensors and configurations has been deployed in estimating walking speed according to [41]. Authors claimed that most body motion during human gait occurs in the lower limbs; therefore, most of the reviewed studies chose to attach the inertial sensors on the thigh and the shank or the foot of the subjects. One study [41] attempted to capture the motion with an accelerometer attached to the chest. Two studies [42, 43] utilized sensors attached at the lower spine to estimate the walking speed. One study additionally used a force/moment sensor [44] as an assisting tool in the system.

According to [39], they are three critical factors for sensor location on body for recognizing different walking speeds, which need to be obtained. Firstly, the correlation between the sensor calculation and the walking speed. In particular, the characteristics of acceleration and angular velocity are different from location to location even if we obtained the same walking speed in different locations. Moreover,

the practicality of extracted walking speed data from sensors needs to be taken into consideration first in selecting a most suitable sensor in favor of selected activity because a walking speed estimation algorithm extracts walking speed information from these characteristics and therefore is sensor location dependent. Secondly, relativity of desired body location and sensor should be attained. The differences ultimately affect the walking speed estimation accuracy and robustness of the algorithm. Finally, Robustness to the interference caused by the abnormal body motions. Authors claimed that any anomalous motions from body would generate errors in the estimated walking speed [39].

Paper [38] also has done notable evaluation of the optimal location of accelerometers for the detection of daily common used activities which include walking, jogging on a motorized treadmill, sitting, lying, standing and walking upstairs and downstairs. Data is collected from six locations on the body, namely the chest, left hip, left wrist, left thigh, left foot and lower back. In addition, they have compared and reviewed successful studies involving activity detection using accelerometers with different locations on body. They have indicated that there is a large variety of placements employed for acceleration perception which also includes placements of multiple accelerometers attached at various body segments [38].

2.4 Activities and Features Selection

There is a notable study [46] which attempts to address the problem of complex activity recognition (cf. section 2.3.2) by using time series extracted from multiple sensors. Authors assumed that each activity has a specific pattern in time series which is called shapelets and a complex activity is composed of a set of simple activity patterns (i.e., shapelets) that are sequential with overlap or without it overtime. The authors built a category of shapelets, to obtain simple activities, and then present three shapelet-based models to recognize sequential, over-lapped, and generic complex activities.

Based on [46], Figure 6 shows an example of two ambulatory activities (e.g., walking and jogging) on the time series collected from a smart phone accelerometer. According to the gait cycle theory (during movement, body scatters and reflects signal strength in a shape of special periodic pattern that shows support and non-support phases produces the body motions. The basic unit of measurement in gait analysis is the gait cycle (GC) or stride), walking and jogging have different patterns that are reflected in the time series. Moreover, they presented categories of selected features based on the relativity of feature and chosen activity. The following list shows five main categories of features utilized in experiments [46].

1. Statical features: min, max, mean, variance, median, and standard deviation values. These basic features commonly refer to the amplitude information.
2. Time and frequency features: auto-correlation, mean-crossing rate, spectral entropy, spectral energy, and wavelet entropy values. These features commonly refer to the time and frequency domain information.

3. Structure features: FFT, DFT, and DWT values. These features can represent the structure of sequences and address amplitude scaling and time warping issues.
4. Peak and segment features: intensity, Kurtosis and peak frequency values of the sequences. These features can capture the interrelationships among data points in a sequence.
5. Coordinate features: radial, polar angle and spherical coordinate; radius, azimuth, and elevation (cylindrical coordinates). They are useful in order to identify the suitable position of sensors.

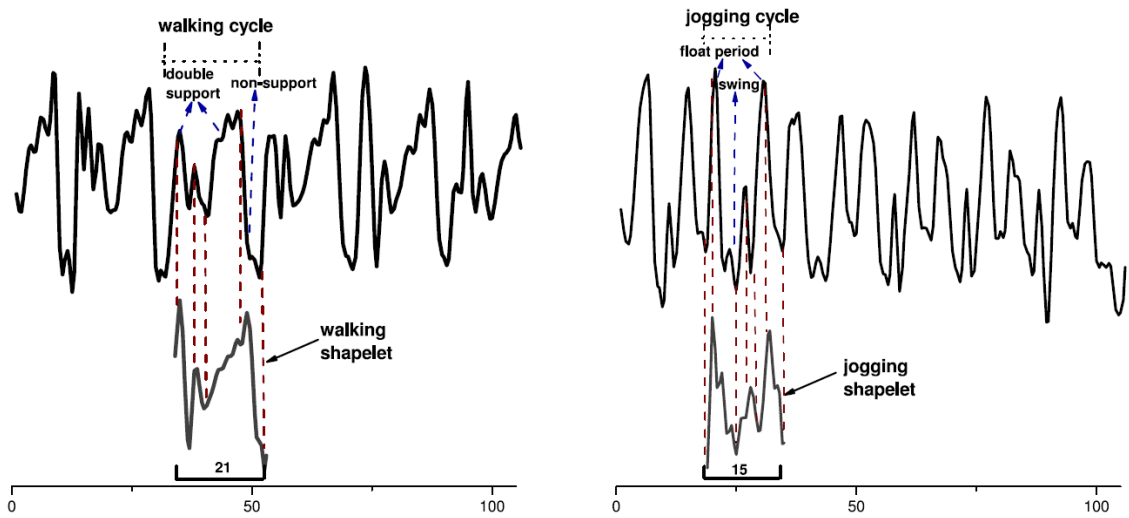

Figure 6: Shapelet of walking and jogging data collected from accelerometer Y-axis [46].

There is another study [10], which introduced features employed for activity recognition from fluctuations in the signal strength of a received RF-signal. According to [10], the following features (with their relative formulas) or their combinations based on their characteristics can be utilized in order to achieving high accuracy and best distinction among activities.

The mean value over a window applied to a signal strength indicates the arithmetic average of the values in the received signal strength obtained by summing the values and dividing by the number of values over window length. Authors believed that it provides the mean values using for ambulatory activity recognition like standing. The mean feature is really useful in a sense that it includes each value in data as variables for measurements.

$$Mean(W_t) = \sum_{s_i \in W_t} \frac{S_i}{|W_t|} \quad (1)$$

Variance is the expectations of the squared of the scattered variables (s_i over window of W_t) from mean values. Variance measure the scattering amount of data.

Authors suggested that it can provides information about vitality of received signal and estimate changes in a receiver's vicinity like human body movements.

$$Var(W_t) = \sqrt{\frac{\sum_{s_i \in W_t} (S_i - Mean(W_t^2))}{|W_t|}} \quad (2)$$

The count of zero crossings counts number of times signal crosses zero over relevant window sections. It measures the fluctuation in a received signal's strength. Authors in [10] claimed that it can be useful in order to count movements in proximity of a receiver because zero crossings happens each time that the received signal strength intensity (RSSI) gradient changes (increase or decrease). So it looks for values passes through zero over a window.

$$g(s_i) = \begin{cases} 0 & \text{if } sgn(s_i - 1) = sgn(s_i) \\ 1 & \text{otherwise} \end{cases}$$

$$ZeroCross(W_t) = \sum_{s_i \in W_t} g(s_i) \quad (3)$$

The standard deviation is the square root of the variance, which identify how far the data is spread and measures the volatility of signal strength which can be used instead of variance.

$$Std(W_t) = \sqrt{Var(W_t)} \quad (4)$$

Median is the feature tool which is more useful for data sets having values which differs largely from others(outliers) and skewed data because median divides the data to two separate categories of high values and low values based on magnitude achieving. Then median becomes robust for data sets with outliers The ordered set of samples are defined as below:

$$W_{t,ord} = \bar{s}_1, \dots, \bar{s}_{|W_t|}; i < j \Rightarrow s_i \leq s_j \quad (5)$$

Then the median is derived :

$$Med(W_t) = s \lceil |W_{t,ord}| / 2 \rceil \quad (6)$$

The normalized spectral energy is a measurement of the energy at various frequencies of the received signal. It measures the cyclic patterns of motions of ambulatory activities such as walking, running or cycling which produce a periodic signature can be really useful for recognition (gait analysis).

$$E_i = \sum_{k=1}^n P_i(k)^2 \quad (7)$$

$P_i(k)$ is the expected probability or dominance of a spectral band k:

$$P_i(k) = \frac{FFT_i(k)^2}{\sum_{j=1}^n FFT_i(j)^2} \quad (8)$$

Then the k-th frequency component is as follows:

$$FFT_i(k) = \sum_{t=(i-1)n+1}^n s(t) e^{-j\frac{2\pi}{N}Kt} \quad (9)$$

The minimum and maximum values represents least and most values of signal strength over a window.

$$Min(W_t) = s_i \in W_t \text{ with } \forall s_j \in W_t : s_i \leq s_j$$

$$Max(W_t) = s_i \in W_t \text{ with } \forall s_j \in W_t : s_i \geq s_j \quad (10)$$

The root mean square (RMS) is defined as the generalized mean with exponent two as it clears from its name. [38].

$$RMS(W_t) = \sqrt{\frac{1}{|W_t|} \sum_{s_i \in W_t} |W_t|^2} \quad (11)$$

Skewness is a measure of the asymmetry of the data around the sample mean. If skewness is negative, the data are distributed more to the left of the mean and if skewness is positive, the data are spread out more to the right [38]. $E(t)$ represents the expected value of the quantity of window components.

$$S = \frac{E(s_i - Mean(W_t))^3}{std(W_t)^3} \quad (12)$$

It is the measurement of how the frequency peak components on data can be sharpened in a distributed data. The normal value of kurtosis is 3 which can varied by how far data is scattered. Basically, kurtosis is getting higher value than 3 if the data components achieve more similar values and it gets lower value of 3 if the data components consist of more scattered data even with outliers (having largely greater values compared to normal values of data).

$$K = \frac{E(s_i - Mean(W_t))^4}{std(W_t)^4} \quad (13)$$

In addition; in [38], the authors have done a literature review in order to find the relative features based on whole-body ambulatory activities (activities related to amount of walking or steps taken over time) besides other works mentioned in 2.3.2. They are different feature sets used in studies but among them, the number of research using feature set of mean, std, rms, var and energy for activity classes of walking, sitting, lying and running are more than others which indicates the popularity of these features employing for ambulatory activities. It is notable that they are also two studies among reviewed study which utilized skewness and kurtosis added by other features in order to recognizing activity set of lying, walking, sitting, running and cycling [37, 71].

There is a study [77] shows that RMS is a handful feature that can be used for especially walking pattern recognition and as input for classifiers. Because; by different subjects and their various fluctuations, the frequency band is changing. Therefore the root mean square of detail coefficient is sufficient feature to extract. The authors also claimed that the Mean metric can be utilized in order to identify activities which also includes no actions in a process like running and standing with no movements which this feature can distinguish interval with activity and while user has stopped. Another study also reveals that Standard Deviation (STD), has been extensively used for activity recognition [78].

2.5 OFDM and 5G System Characteristics

2.5.1 Key Requirements for RF Interfaces of 5G

5G is the advanced and updated version of mobile wireless technologies and standards based on IEEE802.11 that will be widely used for IoT services and wireless technologies and enhanced models and mechanisms for them by employing advanced technologies. According to studies, there have been some essential requirements for 5G network implementation which all together are expected to leverage usage of new radio access technologies and new core network.

- **Increased bandwidth:** One of the key enablers of 5G communication systems is significant high data rate known as bandwidth. The spectrum available for mobile systems have wide variety of wave bands which ranges from microwave bands (less than 6 GHz), centimeter and mm wave bands (28-300 GHz) and wide carrier bandwidths of the order of 1 GHz are possible. However, 5G deployments provide both macro layer and micro layer. The former one refers to microwave bands that provides control plane signaling and the latter one indicate the mm-wave band that carries user plane traffic.
- **Large scale multiple-in-multiple-out antenna arrays at base station** [48, 49]. The use of higher frequencies in 5G network enables 5G system to deploy massive scale antenna arrays in transmitter side for provision of array gain which lead to significantly conquer path loss and allocate spatial multiplexing gain. Based on [49], typical antenna numbers under consideration for the base station employed various values ranging from 256 to 1024 for the mm-wave bands. The antennas consist of cross polarized elements arranged in a two-dimensional array (2D). The array may also consist of constituent sub-arrays [49]. The antenna elements may further consist of groups of dipoles to achieve the desired gain.
- **Advances in MIMO.** The use of 2D arrays and multiuser precoding enables synchronous transmission to multiple users distributed. The number of simultaneous users is limited by the maximum number of spatial streams the base station and environment can support. This is in turn dependent upon the user locations and signal processing methods deployed [50].

- Network density increase: There is a belief [51] that, dependent on the short range path-loss scenario, an unlimited increase in the number of small cells may be counter-productive due to other-cell interference (OCI). This will result in traffic offloading to small cells (with coverage in the tens of meters) especially for indoor hot-spots and dense urban micro cells. High density deployments of small cells will off load the user plane traffic but will still need macro cell coverage (in the microwave bands) to carry the control plane traffic. Increasing cell density may also result in increased other cell interference that will in turn affect any capacity gains.
- New wave-forms: Although Orthogonal frequency division multiplexing(OFDM) has been a great technique and is suitable for large data transmission, there are many ideas for new 5G wave-forms that could bring additional advantages to the new cellular system under certain conditions which will be discussed in Sec. 2.5.3 and 2.5.5 and the references therein. 4G operates OFDM for data transmission because of high spectrum efficiency. It provides excellent spectrum efficiency, it can be processed and handled with the processing levels achievable in current mobile handsets, and it operates well with high data rate stream occupying wide bandwidths. It operates well in situations where there is selective fading. But there are several advantages to the use of new wave-forms for 5G. OFDM requires the use of a cyclic prefix and this occupies space within the data streams. One of the key requirements is the availability of processing power. As such new 5G wave-forms that require additional processing power, but are able to provide additional advantages are still viable.

High frequency has a significant impact on channel characteristics while employing on wireless communication systems, which leads to consideration of many researchers to investigate on channel models. Authors in [63] presented accurate model of shadowing caused by human body presence in an office environment; exploiting 5G network topologies which employ high frequency of 60 GHz link with a high data rate. In this study, it has been shown that the human body has a strong influence on the propagation of mmWaves signals, which is one of the key factor of future 5G communication systems because of employment of high data rate transmission. Their investigation results in effectiveness of Multiple shadowing effects with utilizing higher frequency of 60 GHz being useful to be employed in future 5G systems [63].

2.5.2 5G Sub-Frame Structure

Authors in [6] proposed a 5G frame structure which elaborates main characteristics clearly. Based on the description on the paper and Figure 7, they are some characteristics of the frame structure listed as following:

- Separate Control and Data channel in Time Domain: As it can be seen from the Figure 7, There are two completely separated parts of entire data and control segment. This separation will make the effective pipeline design. These two channel can be sent simultaneously without any effect on their process.

Because one module is responsible for handling control part and another module will monitor the data transmission. This design has two main benefit : decreased latency and power efficient.

- Existence of downlink (DL) and uplink (UL) control channel in every frame: They are two separate sub frame in control part which always are included in each transmitted frame.
- DMRS (DeModulation Reference Signal): The first symbol in data channel is reserved for DMRS. Zadoff-chu sequence because of cross-correlation characteristics of channel.
- Large Subcarrier Spacing: The space between sub carriers is far bigger than previous utilized communication systems (4G) which leads to robustness of systems to impairments especially phase damage. This option results in employment of high frequency up to 60 GHz.

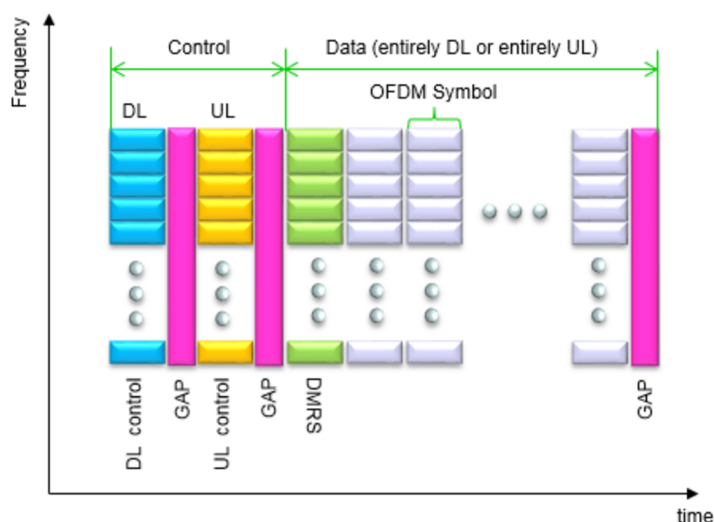

Figure 7: 5G frame structure [6].

2.5.3 5G Waveform Selection

According to [54], the selection of the transmitted radio waveforms for 5G (RAT) communication networks is crucial because of its impacts on transceiver complexity. The authors claimed that the exploited waveform should have the following key requirements that need to be supported by the modulation scheme and overall waveform [54]:

1. The new wave form should be compatible to be transmitted in channels with massive data rate and very large bandwidth. It should cover low, medium and high bandwidths (below 3 GHz and up to 6 GHz).

2. Able to provide low latency and energy consumption transmissions for long and short data bursts, i.e. very short Transmission Time Intervals, TTIs, are needed.
3. Since the control part is separated from data part, the wave form should have the compatibility of quick control over between uplink and downlink.

2.5.4 OFDM Overview

Orthogonal Frequency Division Multiplexing, is a form of signal modulation that distributes the data over a large number of carriers that are spaced apart at certain frequencies and each carrier is modulated at a low rate. This provides the orthogonality in which overcome the demodulation, and frequency selective fading. The orthogonality is achieved by applying inverse fast Fourier transform (IFFT) modulation scheme. The modulated OFDM signal is indicated as follows [57]:

$$y(t) = \sum_{-\infty}^{\infty} \left[\sum_{k=0}^{N-1} x_{k,n} e^{j2\pi k(t-nT_u)/T_u} \right] \cdot \text{rect} \left[\frac{t-nT_u}{T_u} \right] \quad (14)$$

where N is the IFFT length, $x_{k,n} \in \{ x_{0,n}, x_{1,n}, \dots, x_{N-1,n} \}$ is zero mean i.i.d. subcarrier sample sequence which forms the n th OFDM symbol and T_u is the time duration of useful samples in OFDM symbols. The effect of the rectangular window is represented as weighted and shifted sinc function in the power spectral density (PSD) of OFDM signal as follows [56]:

$$P(f)_y = T_u \sum_{k=0}^{N-1} E \left[|x_k|^2 \right] \left| \text{sinc} \left[ft_u - k \right] \right|^2 \quad (15)$$

In (2), each sinc-function represents one subcarrier. In the discrete-time model, the Dirichlet kernel, $\frac{\sin(\pi Nf)}{N \sin(\pi f)}$, should be used. However, the sinc model is justified because the effects of the analogue filter sections of the transmitter should be taken into consideration.

According to the last part of OFDM (prefix), they are two different techniques: one is adding cyclic prefix (CP) and the other one is zero padding (ZP). They both have some advantages and disadvantages will be described in following paragraphs with their related formulas.

In fact, the sinc function produces strong ripples around its center. Hence, orthogonality is required to prevent overlap between sub carriers OFDM subcarriers. Orthogonality is maintained during sub carrier transmission by adding a cyclic prefix which also can identify the starting point of each sub carriers. Besides the issue of orthogonality maintenance, there are other issues which should be handled in order to sufficient OFDM transmission. One of them is Inter-carrier Interference between Subcarriers (ICI) which is caused by multipath fading and doppler effect and can be solved by sufficient windowing methods. The other one is High Peak to Average Power Ratio (PAPR) in which the IFFT block attains a spiky power spectrum and can be fixed by applying proper filtering mechanisms [54].

CP refers to guard times between each two pairs of neighboring sub carriers which contains no information inside and it is usually used to preserve orthogonality and allocate multipath-prone channel and reliable synchronized process. The basic idea is to replicate part of the OFDM time-domain waveform from the back to the front to create a guard period. The duration of the guard time T_g should be larger than delay spread to prevent overlapping of sub carriers (also called inter-symbol interference (ISI)) then it will increase the total OFDM symbol duration to $T_s = T_u + T_{CP}$, where T_{CP} is the duration of CP. Besides the simple implementation of CP and good synchronization, it is capable of causing possible nulls at sub-carriers in fading channel and it increases required transmission bandwidth. The new generated symbol is referred as CP-OFDM symbol and it can be expressed in the following form:

$$y(t) = \sum_{-\infty}^{\infty} \sum_{k=0}^{N-1} x_{k,n} e^{j2\pi k(t-nT_s-T_{cp})/T_u} \cdot \text{rect}\left[\frac{t-nT_s}{T_s}\right] \quad (16)$$

Because the data samples of CP are copied data, their FFT components are contained in the interval $[0, N-1]$ [26]. Consequently, the PSD of CP-OFDM is evaluated as follows:

$$P(y)_f = T_s \sum_{k=0}^{N-1} E\left[|x_k|^2\right] \left| \text{sinc}\left[T_s\left(f - \frac{k}{T_u}\right)\right] \right|^2 \quad (17)$$

Let $q = \frac{T_{cp}}{T_u}$, then $\frac{T_s}{T_u} = 1 + q$. Equation (4) can then be rewritten as follows:

$$P(f)_y = T_s \sum_{k=0}^{N-1} E\left[|x_k|^2\right] \left| \text{sinc}\left[ft_u - k\right] \frac{\cos[q\pi(T_u f - k)]}{1 + q} + \frac{\cos[\pi(T_u f - k)]}{(1 + 1/q)} \text{sinc}[q(T_u f - k)] \right|^2 \quad (18)$$

As a result, the CP changes the zero intersections of the sinc function. In (5), the cosine factor changes the position of sidelobe peaks of OFDM spectrum, that is, at the middle between two subcarrier centres, the value changes by the additional term $(\cos[q\pi(T_u f - k)])/(1 + q)$.

There is an alternative case of guard interval, which is the zero padding (ZP) model. In a ZP-OFDM system, the guard interval is filled with zeros instead of cycled data samples [56]. As a result, the spectrum of ZP-OFDM scheme is similar to the case of OFDM without CP, and (2) is valid to represent the ZP-OFDM scheme. However, the normalisation factor T_u has to be replaced by T_s to model the time extension. One the benefits of ZP is if the frequency response at the subcarriers frequency is zero (deep fading), then a transient response is still available [57].

2.5.5 OFDM Enhancements for 5G

While most of the wireless systems have employed many benefits of using orthogonal frequency division multiplexing (OFDM) scheme as the basis of physical layer; the enhancement of OFDM to be compatible with new cognitive radio systems,

comes into consideration. OFDM is commonly considered also as the first candidate technology for advanced cognitive radio, dynamic spectrum use including the 5G system development.

In one hand, the major advantage of OFDM is its robustness against multi path propagation. Thus, it is suitable to be implemented in wireless environments. The introduction of cyclic prefix made OFDM system resistance to time dispersion. OFDM symbol rate is low since a data stream is divided into several parallel streams before transmission. This makes the fading is slow enough for the channel to be considered as constant during one OFDM symbol interval [57]. Cyclic prefix is a crucial feature of OFDM used to combat the inter-symbol interference (ISI) and inter-channel-interference (ICI) introduced by the multi-path channel through which the signal is propagated. The basic idea is to replicate part of the OFDM time-domain waveform from the back to the front to create a guard period. The duration of the guard period T_g should be longer than the worst-case delay spread of the target multi-path environment. The use of a cyclic prefix instead of a plain guard interval, simplifies the channel equalization in the demodulator [57].

In the other hand, one of the major disadvantages of OFDM is its requirement for high peak-to-average power ratio (PAPR). High PAPR not only brings higher requirements on transmitter Power Amplifier (PA) linearity, but also reduces the amplifier efficiency. Secondly, the synchronization error can destroy the orthogonality and cause interference. Phase noise error and Doppler shift can cause degradation to OFDM system. Hence, a lot of effort is required to design accurate frequency synchronizers for OFDM to be sufficient for 5G network systems. Therefore, various side lobe suppression techniques have been proposed in the literature to mitigate these effects [57]. Authors in [58] also explained; since many subcarrier samples are added via inverse fast Fourier transformation (IFFT) operation to OFDM, it has high peak values in time domain. This demerit results in lower power efficiency of the network devices because a high PAPR causes large back off at the input of the power amplifier and it will lead to lower signal-to-quantization noise ratio (SQNR) of the analog-digital convertor (ADC) and digital-analog convertor (DAC) while degrading the efficiency of the power amplifier in the transmitter.

Authors in [58] proposed Discrete Fourier Transform – spread – OFDM (DFT-s-OFDM) as a candidate for new 5G systems which they claimed it is a solution for conversion of serial to parallel data transmission in time which the former one is in a shape of single carrier transmission [58]. According to paper, this candidate (DFT-s-OFDM) affects usability of OFDM in a good way for 5G because of having many benefits in terms of decreasing PAPR. DFT-s-OFDM is the implementation method of single carrier-FDMA in the frequency domain, which performs DFT-based precoding before IFFT modulation in the OFDM modulation process. This indeed leads to significant benefits in terms of lower PAPR, inherent frequency diversity in wideband transmission and having lower sensitivity to frequency offsets and time-selectivity [58]. Authors in [54] also believe that DFT-s-OFDM is flexible to be used in 5G networks because it is adopted to uplink scheme of the 3GPP Long Term Evolution (LTE) and it is technically similar to Orthogonal Frequency Division Multiple Access (OFDMA) [54].

2.6 Conclusions

In this chapter, we have discussed several interesting and notable studies that are related to our work. However, those research studies exploit many device-free techniques in order to detect and analyze human behavior. Our study is unique in a way that we investigated on a 5G prototype system in order to recognize human walking speed. From our analysis, we also highlight the human presence detection in vicinity of Transceiver 5G devices leading to the identification of pros and cons of using the system for human motion recognition in potential of IoT new technologies.

3 Walking Speed Recognition

3.1 Motivation

In this section, we investigate the use of channel state information experimentally collected from a 5G prototype system to perform recognition of human walking speed in an indoor environment. We conducted three different classes of speeds, taking into account the comparison between recognition via radio frequency and acceleration sensor on carried mobile phone. We evaluated the impact of sub channel count by employing various number of carriers. We applied features and the classification performance (with various algorithms) is investigated. We has an opprtunity to conduct actual realistic experiments leads to optimal classification of our data. To the best of our knowledge, walking speed recognition from 5G properties approach has not been used in activity recognition community, particularly for speed perception. The research on walking speed detection is enlightened by three objectives:

First of all, the technologies that can be employed to provide potential activity capability (USRP devices, 5G system characteristics, etc.). Secondly, evaluation of sub carriers influences in better data transmission to handle noise and impairments. Moreover, accurate experimental setup (testing experiments several times). Finally, Applying the most proper feature sets and classification algorithms.

3.2 Research Methodology

The first section of this chapter describe our experimental testbed and the details of the utilized system properties. We then discuss the data collection process, which consists of two phases: RF and acceleration sensing, including tools we developed for this purpose. Finally, we will focus on the processing we performed on the data which includes four main segments being described in 3.5.

3.3 System Description

Two USRP NI 2932 devices (covering center frequencies from 400 MHz to 4.4 GHz) were used as Tx and Rx devices with a maximum RF-bandwidth of 40 MHz (see Appendix A.4). The TPLINK omni-directional transmitter antenna features a gain of 18 dBi and in receiver side a planar antenna with a gain of 5 dBi was employed (Figure 8 (a) and (b)). We executed measurements in an indoor corridor (Figure 8 (c)) with multiple office rooms placing in corridor. The height, width and length of corridor are 2.5 m, 2.2 m and 27 m respectively covering corridors, rooms and cubicles and the material of wall is bricks. Tx and Rx devices have been positioned over the floor at a height of 1.5 m in line-of-sight of each other at a distance of 20 m. The 5G prototype system has specific characteristics listed in Table 1. The utilized bandwidth based on Table 1 is 12.48 MHz.

Table 1: 5G prototype system characteristics

Characteristics	Value
Center Frequency	3.45 GHz
OFDM carriers	73 (52 for data)
One OFDM symbol length	$4.16\mu s$
Sub-carrier spacing	240kHz
Carrier Bandwidth	12.48MHz



(a) Transmitter

(b) Receiver

(c) Set-up

Figure 8: (a) Shows the employed transmitter with a laptop in order to control data transmission. (b) Illustrates receiver side with an employed monitor to control data transmission and (c) shows the corridor which experiments were executed and the arrow indicates the distance between Tx and Rx

In this scenario, we evaluate the impact of various number of OFDM carriers as multiple channel of data transmission. We employed channel state information (multiple sub-carriers in OFDM mechanism) and investigate on analysis the best situation for data transmission in our system based on the number of utilized carriers.

3.4 Experimental Procedure

In order to detect walking speed, we measured features(details in 3.6.2) from five young healthy persons including three males and two females aged 23-30. Each person walked the same distance at three speeds: slow (0.7 meters per seconds (m/s), medium (1.3 m/s) and fast (2.2 m/s)). The idea behind choosing these speeds is gait transition from human walking and running. Individuals have two distinct gaits (walking and running) and the natural transition point from walking to running is 2.2m/s [52]. We used a Metronome to help participants maintaining walking speed during experiments. Participants practiced using metronome before the experiments. Before the actual evaluation began, the participants were asked to perform a practice task in which they walked straight for approximately 20 m. They were given the following rules: 1) walk to the sound of the metronome, 2) face straight ahead while walking. In the actual evaluation, each participant walked straight for 20 m with three different speeds as mentioned above. They were instructed to stand at the

Table 2: Walking Speed Setting

Speed	Time	Metronome value
Slow 0.7 ms	28 seconds	each 50cm was set with 60 bpm
Medium 1.3ms	16s	each 50cm was set with 120 bpm
Fast 2.2ms	10s	each 80cm was set with 120 bpm

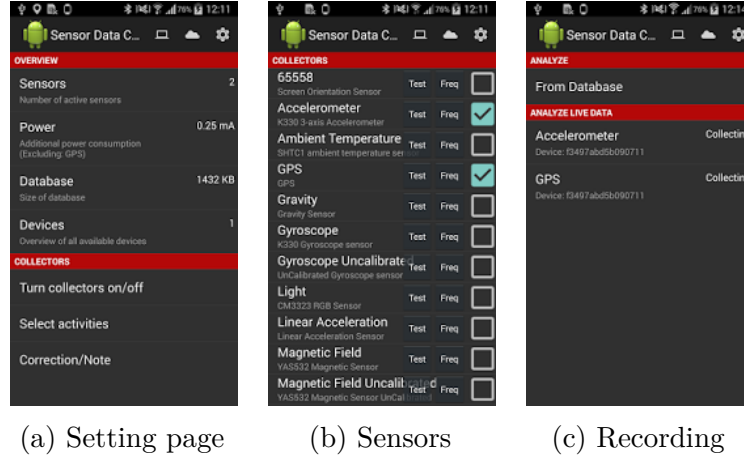

(a) Setting page (b) Sensors (c) Recording

Figure 9: Sensor data collector application [53].

starting point and jump for a second in order to make the data easier for recognition of beginning and ending of actual transmitted data. As further orientation, the ground was marked with a tape in distances of 1 meter and 50cm between transmitter and receiver. In Table 2, the details of each speed required time and distance and metronome values has been indicated. Particularly, each metronome value (beat per minute) was assigned to specific speed which was also set with marks on the floor.

For acceleration sensing, Sensor Data Collector application from Android [53] is used to collect the data from accelerometer and gyroscope (see Figure 9). This application is capable of recording data in csv format which is easy to import on MATLAB application for data process. As you can see from the figure, They are a wide variety of sensors of the wearable device which can be used (see Figure 9 (b)). Moreover, the user interface is in a way that user can track sampling rate and record several sensors simultaneously [53].

Mobile phone was in airplane mode, Wi-Fi was off, and Samsung Galaxy S5 was used. The phone recorded only acceleration sequences and it was not utilizing the RF interfaces. The subjects wore the phone in the front pocket of their trouser, which is a reasonable location for walking speed estimation, since sensing at the lower spine of the body has been shown to achieve higher accuracy for walking speed estimation. Since we aimed to achieve realistic accuracy, we accepted possible sensor displacement or rotation as natural measurement noise.

Table 3: Show an example of slow speed sample attributes

Attributes	Values
cslow1	10390601x1
islow1	10390601x1
rslow1	10390601x1
gridslow1	73x142337
fftslow1	64x142337

3.5 Data Collection

The data was collected in two phases: retrieving data from RF signals and collecting data from accelerometer.

3.5.1 RF Data

The RF data were collected from five subjects, 3 males and two women aged between 25-32. We collected 45 samples from three walking speeds classes in total which each activity includes 3 samples. The users were given a brief introduction of the different speeds, direction and using metronome. Table 3 shows an example of a slow speed sample attributes extracted from one subject. As you can see from the figure, they are three arrays of complex, imaginary and real values of raw data which has been changed to matrix for further process(see section 3.6). The gridslow1 array is a matrix with size of 73x142337 in picture which identifies carriers and OFDMs. In addition, fftslow1 is matrix prepared for data process but with FFT size of 64 (see section 3.6).

3.5.2 Acceleration Data

Sensor data collector enabled us to collect the data from the mobile phone accelerometer and process it with MATLAB on computer. we gathered the 3-dimensional acceleration data from the accelerometer on mobile Android phone. Each user performed the experiments 5 times for each set of walking speeds classes while carrying mobile phone in front pocket of their trousers. I asked subjects to jump for the first 2 seconds of starting to walk and finishing the distance.

3.6 Data process

3.6.1 Frequency Domain Analysis

Figure 10 shows the data transformation to be shaped as a matrix. The received data is a sequence of OFDM symbols with a gap of 200 μ s between each in time domain. As you can see from the figure, the initial data has separated control and data part which are a pipeline of OFDM symbols consist of 64 carriers for each (cf. section 2.5.3). Then, we applied FFT with a size of 64; but for data process, we could only use 52 potential subcarriers due to FFT characteristics, 12 of them

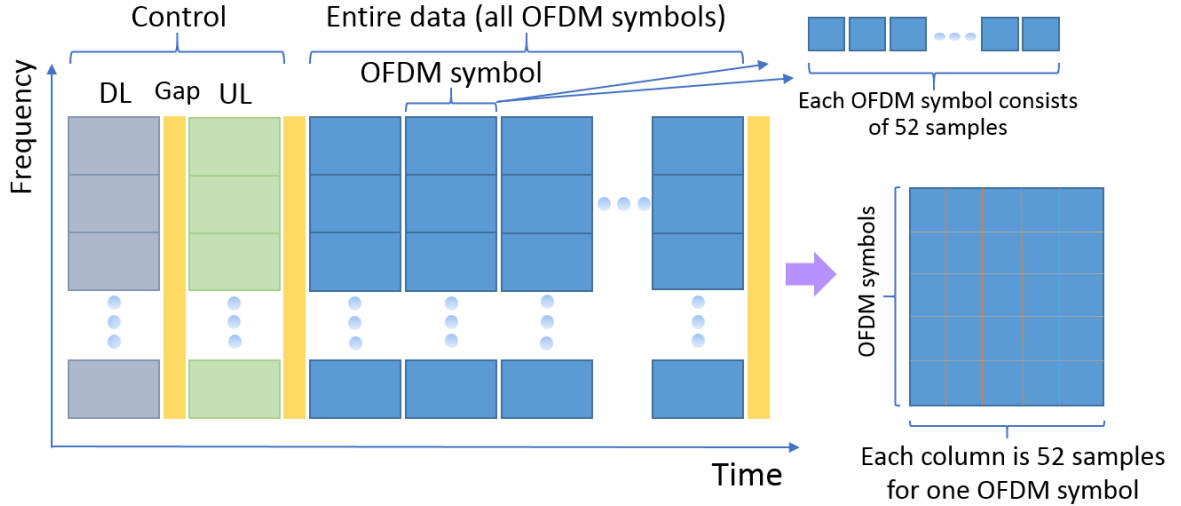

Figure 10: OFDM carriers and symbols as transmitted data in 5G prototype system.

are unused (sometimes referred to as 'Virtual carriers' or 'null carriers' [79]). After FFT implementation, we took 12 sub carriers from our matrices as you can see in figure 11 (the 12 virtual carriers are shown as a blue bar in the middle of carrier in left side figure). It shows an example data sample of slow class from one subject. The matrix in the left side is before applying FFT (5G system characteristics as having separate control part.) and the one in the right side reveals only 52 potential sub carriers.

we removed the 12 carriers which were information-less by visualizing the matrix of OFDMs and carriers using the `imagesc` syntax in MATLAB to obtain the useful carriers and

Then we constructed five different use cases to investigate the impact of different number of channels:

- Extracting only one carrier to analyze and compare with single channel data transition
- Utilizing 13 carriers which were selected in a distributed order.
- Extracting 26 carriers which is half of all carriers.
- Extracting 39 carriers.
- Employing all 52 carriers.

It is notable that, selected carriers were equally distributed among all carriers and in order to compare with acceleration case we also constructed sixth case to elaborate acceleration sensing result. After frequency domain signal processing, we obtained data for extracting features.

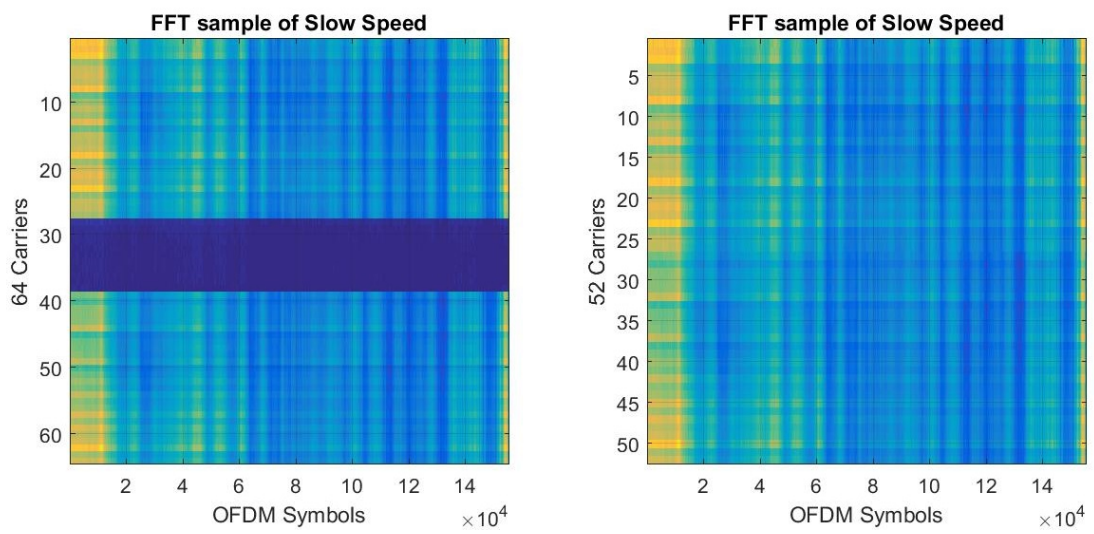

Figure 11: FFT sample of slow speed exploited from one subject before and after removing virtual sub carriers.

3.6.2 Feature Extraction

We apply similar features in all cases considered, but adapted to the respective recognition systems. In particular, we exploit both time and frequency domain features and investigated mean, standard deviation, variance, root of the mean squared (rms), frequency spectral entropy, kurtosis and skewness. From these, we manually exploited various combinations in order to identify those which are most characteristic to describe the respective recognition cases.

For acceleration sensing, we identified and extracted distinct features in the accelerometer data for each specific walking speed that I wanted to detect. I utilized the same feature sets as walking speeds from RF evaluation. First I obtained the magnitude from data which consists of only y and z-axis components since x-axis is for detecting left and right and it is used if we want to make turns while walking for features in time domain consisting of Mean, Rms, Var, Std, Kurtosis, Skewness. In addition, I used only y-axis for Entropy which is frequency domain feature. The output is a row vector consisting of 6 entries which I used for classification part in next section.

3.6.3 Windowing Mechanism

Windowing is a core requirement for stream processing applications to perform set-based operations and feature extraction. The window "slides" across the time series, with no overlaps. and it is moving horizontally while it is getting the feature values of each column (OFDM carriers). Windowing mechanism includes two phases. First, by applying the function of window =Feature(matrix,[],1) : it operates along the columns of X and returns the feature value of each column which is carriers of one OFDM symbol in matrix (arrows in figure 12). Then our feature vector goes along the rows of matrix and returns the feature value of each window sized row. So each feature gets the values vertically based on the window size while the window is moving forward and all the windows have a fixed length. Figure 12 shows a representative example of windowing mechanism on a matrix which includes OFDM symbols as columns which each one has 52 carriers as rows. It is notable due to different use cases for OFDM walking speed, we applied our window length on different size of OFDM carriers.

The feature vectors are deployed to FFT values which store all feature values in separate rows of an array being used for classification. We employed windowing mechanism in a loop function with a size of iterations (size of signal divided by selected window size) in MATLAB workspace. Each the window mechanism is applied to signal and store feature values in an array consisting of 7 columns for feature value and a column for labeling classes of activity (0, 1 and 2 which represents slow, medium and fast speed). The feature array further will be used for classification.

We investigated on different window sizes which includes from very small ones up to big ones to evaluate the best result and highest accuracies. For example, we applied window length of 20 or 30 which means (3.87 ms and 5.91 ms window length) over data which we did not get high accuracy as we expected because the data length was big and we required bigger window to include more values in order

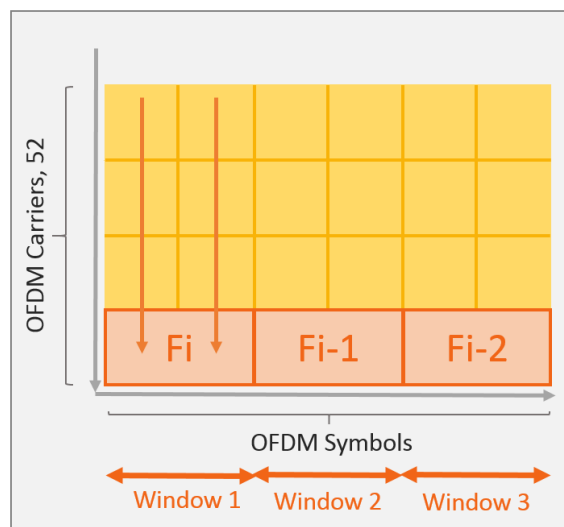

Figure 12: Windowing mechanism example. Sequence of features which are indicated by F_i, F_{i-1}, \dots are applied to each window slice

to find the maximum value and peak of accuracy for avoiding fault measurements for classification described in next section. On the other hand, we also analyze data with really big window length like 5000 or 10000 which refers to 1.0167 s and 2.033 s respectively. Thus, the best result was via window length of 20 milliseconds. In the OFDM system, this window length translates to 100 OFDM symbols and $20338\mu\text{s}$, due to the gaps in the recording added to data length.

3.7 Data Analysis

3.7.1 Classification

Classification was conducted exploiting the Matlab Classification Learner toolbox (see Appendix A.1). For classification algorithm, we selected KNN classifier which the best result achieved (see Appendix A.2). The choice of different classifiers has historical reasons as investigations have been started in different projects. In any case, since optimized toolboxes have been utilized in both cases, we do not expect significant impact on the classification results if methods were changed. For the presence-detection case, we exploited five samples for each case (four cases) which we took one testing set (including 1 sample from each case) in a different day from training subsets. Consequently, we applied leave-one-subject-out cross validation. Finally, for the recognition of walking speed with acceleration and RF-data, we divided the data into 5 subsets, one for each subject, and again we employed leave-one-subject-out cross validation(see Appendix A.3).

Figure 13 is a schematic representation of Leave-one-person-out-cross-validation. The figure shows training set which is split into 5 subsets, one for each subject and the process of training and testing is repeated five times. In each iteration, one subset is used to test a prediction model that is trained on the other 4 subsets. The estimated parameters of the training are used to classify the single removed observation. The main process repeated 5 times so that each observation was removed and classified once.

Then, for classification part, we merged four tables from four subjects (each one includes 7 feature attributes and its label (0,1 or 2)) as training set. Then we applied KNN algorithm from Classification Learner tool in MATLAB to our training data set. Next, we imported the KNN model to MATLAB workspace (see A.1.4). Accordingly, we applied the function from our exported train model to the testing set.

3.8 Conclusion

In this chapter, we evaluated walking speed detection in six different scenarios including various number of channels count and we compared the results with acceleration sensing. Results from RF are evaluated in section 5. We have done the realistic actual experiments in order to elaborate our results using a 5G prototype system which is capable of high carrier frequency of 3.45 GHz. Data process has been done in Matlab application.

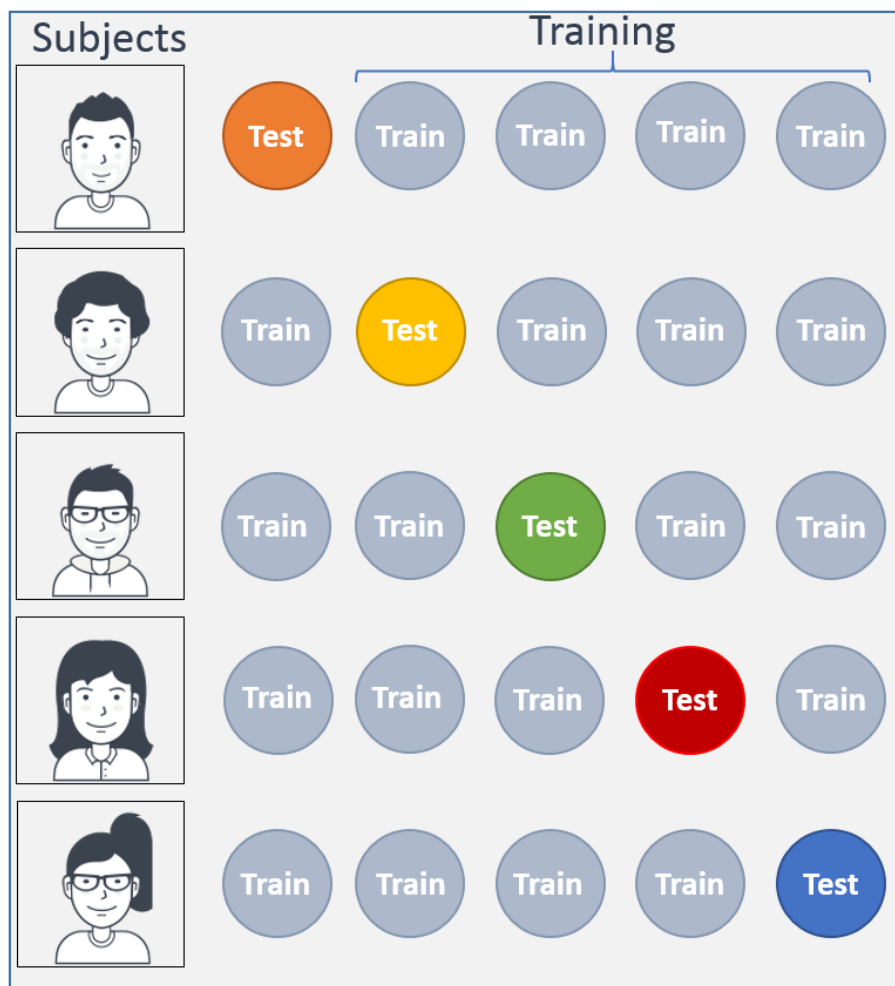

Figure 13: Schematic representation of Leave-one-out-cross-validation of walking speed detection

4 Presence Detection

4.1 Motivation

This chapter evaluates the investigation of human presence detection from a 5G prototype system exploits human body special impacts on signal signatures which can reflect the radio signals by making attenuation on signal in the radio propagation signature while posing in vicinity of transceivers. The presence of a human subject in the monitoring room, within the wireless network range, results in significant received signal strength variations at the receiver’s input. Consequently, it inspired us to design and implement the through walls system using similar settings (5G prototype system but with updated version of USRP devices) like walking speed recognition to evaluate the human presence in vicinity of transceiver devices. The impact of impairments of subject in adjacent of transceivers is analyzed by conducting various cases; subject near transmitter, subject movements close to receiver.

4.2 Research Methodology

This section is organized as follows. Section 2 provides detailed description of experimental testbed. presents the system architecture. Then we describe the data collection process, including all scenarios proposed and tools developed. Section 4.6 discusses the whole data process which categorized as following FFT analysis part, feature extraction, windowing mechanism and classification.

4.3 System Description

For this experiment, we used universal software radio peripherals (USRP) devices for the instrumentations; USRP X310, covering center frequency up to 6GHz as transmitter (Tx) and receiver (Rx) (see Appendix A.4.1). We utilized TPLINK omni-directional antennas with a gain of 18 dBi in both Tx and Rx sides. Tx and Rx are positioned in two distinct office rooms, separated by a concrete wall (see Figure 14).

In contrast to other radio-based systems exploited for human activity recognition, it features a large sub-carrier spacing (240 KHz) to enable shorter symbol length. Consequently, this large sub-carrier spacing enables the system to operate at higher carrier frequencies and with improved robustness to phase noise compared to LTE systems [6].

4.4 Experimental Procedure

We investigated the detection of presence in indoor environments in which the transmit and receive devices are separated by furniture and a wall. In addition, we were careful to conduct the experiment on days where the offices have been partly occupied by other subjects to cover natural environmental noise. In the experiment we distinguish between an office in occupied or non-occupied state. In the occupied state, a person was moving freely in the office while in the non-occupied state, the



Figure 14: The figure shows Rx and Tx side (respectively) which are separated with a wall in middle.

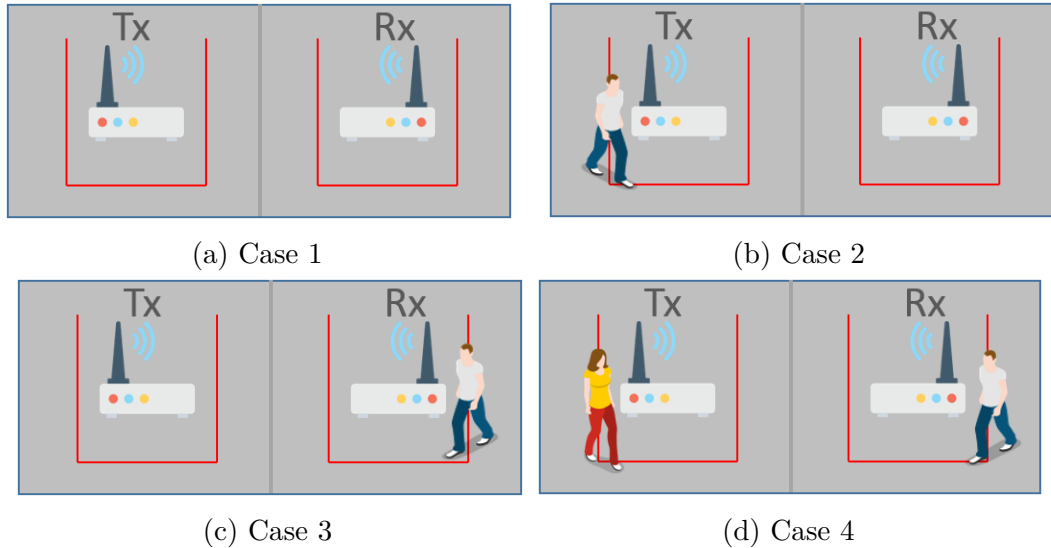

Figure 15: The four cases considered for presence detection covering two neighboring office rooms.

office was only occupied by occasional other workers sitting and working in front of their computers. In addition, we generated special cases in which another subject is walking in proximity of the transmitter in order to investigate whether movement farther away from the receive device would impair the recognition performance. Measurements have been taken over a number of days and on several times of day. The four different cases considered are depicted in Figure 15.

- Office with Rx device is occupied by office workers but no subject walks or moves in the proximity of Tx and Rx.
- A single subject moves freely in the proximity of Tx (noisy case).
- A single subject moves freely in the proximity of Rx while no subject moves near Tx.
- A single subject moves freely in the proximity of Rx and another subject moves freely in the proximity of Tx (noisy case).

We repeated each of the four cases five times over the course of several days where each recording lasted for at least five minutes. Both environments are natural office environments and differed from each other in the furniture installed (cf. figure 14).

4.5 Data Collection

For the data collection, set of normal human movements (Walking) and the absence of human activity were collected. The duration of experiments took about one hour and 40 minutes but in different times and days from all 4 cases (discussed in previous section); this includes 5 data instances for each case (each one lasting 5 minutes).

Maximum number of two subjects performed the activities in entire area of Rx and Tx neighboring, as shown by the red line in Figure 14, and represents the normal walking movements of a single person around the experiments test-bed. Just like RF data in waling speed procedure, The raw data consists of all complex, imaginary and real values which is transformed to a matrix after FFT implementation.

4.6 Data Process

For data process, we followed the same procedure as walking speed in a way that we applied FFT to data and reshaped them as a matrix then we put features vectors and create tables using for classification. All the process has been done in MATLAB. We constructed FFT attributes of raw data as a shape of matrix which consists of only 52 subcarrier for each sample to be processed.

4.6.1 Feature Extraction

For the presence detection case from the same prototype OFDM system, we again applied the same feature sets to data for classification procedure in next step (including: Mean, Rms, Var, Entropy, Std, Skewness and Kurtosis). In addition, we added more features including : minimum and maximum value of signal strength over the window and median value. The feature vectors are deployed to FFT values.

4.6.2 Sliding Window Mechanism

All the process of windowing is like previous experiment(walking speed). In the presence detection scenario, we applied the above features over a window of 60 milliseconds length. In the OFDM system, this window length translates to 300 OFDM symbols and $60814\mu s$, due to the gaps in the recording added to data length. The feature vectors are deployed to FFT values which store all feature values in separate rows of an array being used for classification.

The feature vectors are deployed again to FFT values which store all feature values in separate rows of an array being used for classification. We employed windowing mechanism in a loop function with a size of iterations (size of signal divided by selected window size) in MATLAB workspace. Each time the window mechanism is applied to signal and store feature values in an array consisting of nine columns for feature value and a column for labeling classes of activity (0, 1, 2 and 3 which represents class A, class B, class C and class D(see Table 4)). The feature array further will be used for classification.

4.7 Data Analysis

Classification was conducted exploiting the Matlab Classification Learner toolbox. For the presence-detection case, we exploited five samples for each case (four cases) which we took one testing set (including 1 sample from each case) in a different day from training subsets. Consequently, we applied leave-one-subject-out cross validation.

For classification procedure, we put four tables from four subjects (each one includes 9 feature attributes and its label (0,1,2 and 3)) as training set. Then we applied KNN algorithm from Classification Learner tool in MATLAB to our training data set. Next, we imported the KNN model to MATLAB workspace (see [A.1.4](#)). Accordingly, we applied the function from our exported trained model to the testing set.

4.8 Conclusion

So far, we have discussed the whole process of walking speed detection in details in this section. It is concluded that the 5G prototype system is capable of recognizing human movements in vicinity of transceivers especially receiver device in noisy environments like work office. The results are indicated in next section.

5 Results

In this section, we present the evaluation of our proposed technique for all three use-cases (Walking Speed, Acceleration Sensing and Presence Detection) showing that it satisfies the design goals of being accurate, and robust against the changes in the environment.

5.1 Walking Speed Detection

In this case, we investigate the accuracy for walking-speed recognition from our 5G prototype system and compare the achieved accuracy with inertial-measurement-based acceleration sensing and recognition of walking speed. In addition, we investigated the impact of the number of carriers considered on the recognition performance.

We exploited various combinations of carriers and carrier count selected and compared the results achieved to the accuracy reached for acceleration sensing. For this purpose, we constructed six cases in which selected carriers were equally distributed between all carriers. Case (a) features only a single carrier (26th, center carrier). Case (b), case (c), case (d) and case (e) represent thirteen, twenty-six, thirty-nine and 52 carriers, respectively. Case (f), finally, represents acceleration data. Results are summarized in Figure 16.

The confusion matrix for case (a) (Figure 16 (a)) reveals that slow speed is well distinguished from fast speed but medium speed is partly confused with fast speed and also slow speed. The overall accuracy achieved in this case is 0.662. This single-carrier case is most similar to traditional RSSI-based recognition but with higher sampling frequency and sampling accuracy. We gradually increase the number of OFDM carriers considered from case (b) to (e) which, in turn is rewarded by an increase in the recognition accuracy up to 0.946 in the 26-carrier case. With thirteen carriers (case (b)), already the confusion between medium and fast speed can be reduced, resulting in a higher average accuracy of 0.68. However, medium speed still possesses low accuracy of 75%. This trend continues with the consideration of further carriers and results in a rise in accuracy with each additional 13 carriers considered. Figure 16 (c) displays the third case in which we can observe the highest accuracy for slow, intermediate and fast speed (94% and 95% respectively). For the fourth scenario, we considered thirty-nine carriers and we achieved an average accuracy of 92.66% (Figure 16 (d)). We examine the fifth case by exploiting all fifty-two carriers over OFDM symbols, which results in a drop of 0.06 in accuracy (see Figure 16 (e)). We account this to the overlapping and, due to noise, partly contradictory information obtained from the neighboring carriers. According to figure 16 (c), the best result is achieved when we applied only half of the available carriers (26), leaving a spacing of one carrier between each considered OFDM carrier.

We also plot the confusion matrix for the acceleration case (case (f) in figure 16 (f)) for comparison. The overall accuracy achieved is 0.7033, which demonstrates that we are able to reach comparable, or potentially better accuracy from RF-sensing than what is possible from classic acceleration sensing. As can be seen from figure 16 (e),

accuracies of 67% and 72% are observable from slow and medium speed due to their interference. However, acceleration-based process was able to infer the speeds with an average accuracy of 70% only.

Figure 17 reveals a three dimensional (3D) plot of the best result achieved from third case which includes 26 carriers. We applied many combination to achieve the best visualization of features compound which the figure shows the utilized Kurtosis, Rms and Mean as three selected features. Besides the little interferes of slow class with medium and fast, they are well distinguished. In addition, it shows that slow and medium classes are more clustered and fast speed class is more scattered which reveals that people could attain slow and medium speeds more similar to each other. As we can see from figure 17, Rms is the best feature to show discrimination of three sets of classes. Rms is placed in Y-axis and show that since humans can achieve similar velocities with lower speed than 2 m/s for our third case (fast speed) the data is more scattered. As we discussed in 2.4, Rms can discriminate walking patterns while mean feature utilized mostly to employ for activities like lying, sitting and standing.

Figure 18 represents a bar chart of all achieved accuracy in which it shows that when we increase the number of carriers from 26 to 39, there is a slight lower accuracy of 3% and for the fifth case (all 52 carriers) it declines to 88% which is due to distortion of signals and noise added to the signal as it propagates through a transmission medium with bigger size of transmitted data (adding more OFDM carriers will increase size of data). But, it is still robust to noise and can recognize the walking speed with an accuracy of 88%.

5.2 Presence Detection

For presence detection, we utilized 26 equally distributed carriers from all 52 carriers¹. Table ?? shows the overall accuracy achieved for all cases. Accordingly, we conducted five cases by combining various scenarios to evaluate the results.

- Class A indicates the classification of only case 1 and 3 (subject next to Rx and no subject close to Tx).
- Class B represents the classification of the combined (case 1 and 2) and (case 3 and 4).
- Class C shows the classification of combined (case 1 and 2), 3 and 4
- Class D represents three cases of 1, 3 and 4
- Finally, the last case elaborates all four cases

¹see section 5.1 for a discussion of the impact of the choice of OFDM carriers



Figure 16: Confusion matrices of three walking speeds recognized by K-NN classifier for all six cases have been indicated in this figure. Average accuracy is also shown for each case.

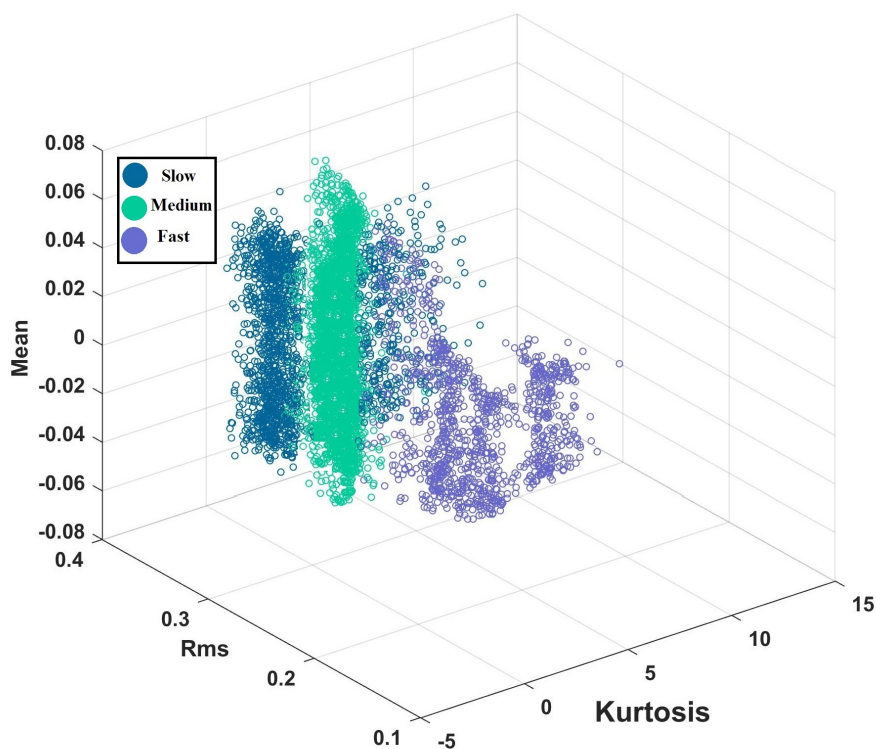

Figure 17: 3D plot of three selected features through all speeds for the best case (26 carriers). It reveals that beside the slight interference between slow, medium and fast speed, they are well distinguished.

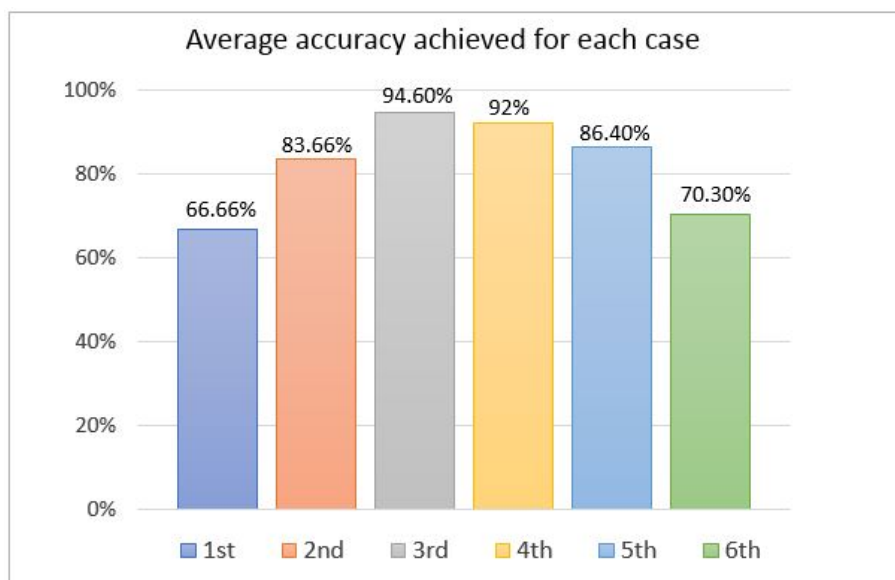

Figure 18: It indicated the achieved accuracy of all six cases in a given order from left to right.

Table 4: Accuracy achieved for different set of classes of presence detection

Set of classes	Accuracy
(A) case 1 and 3	0.928
(B) case 1+2 and 3+4	0.798
(C) case 1+2, 3 and 4	0.729
(D) case 1, 3 and 4	0.82
(E) case 1, 2, 3 and 4	0.697

As it can be seen from table ??, the best result is achieved for the non-noisy recognition case (A) where no subject caused noise close to the transmitter. However, movement farther away from the receiver has only small impact on the recognition accuracy. We can see this by including the cases where a person has been moving close to the Tx side. We observed that, despite the noise generated by the person in proximity to the transmitter, the recognition performance is degraded only gently to 0.798. The system is robust to such environmental noise and can still detect the overall situation correctly. It is observable from both Figure 19 and table 4 that case D has a better accuracy compared to case B and C which is due to removing the case when subject is in adjacent of Tx (case 2). It is notable that the class B has less accuracy compared to class A because of more noise which is added due to getting case 3 and 4 as separate cases. Finally, in favor of our expectation is case E which includes more impairments on received signal due to more noise causes by environment which has nearly similar accuracy compared to case B with a drop of 0.032.

The confusion matrix for case (a) (Figure 19 (a)) reveals that case 1 is well distinguished from case 3 due to non existence of subject in adjacent of TX. but medium speed is partly confused with fast speed. We the number of OFDM carriers considered from case (b) to (e) which, in turn is rewarded by an increase in the recognition accuracy up to 0.946 in the 26-carrier case.

Class B shows the combination of (case 1+2) and (3+4) as two single cases, which the overall accuracy of 79% is achieved. As we discussed before we have a drop of 13% in accuracy because of adding the situation of subject movement around Tx. It can be seen from Figure 19 (c),(d) that both class C and D employed three sets of cases which we used case(1 and 2) as single case for class C which results in a rise of 1% for recall value of case 3. The overall accuracy achieved for class E is 0.68, which demonstrates that we are still able to reach comparable accuracy compared to other classes (see Figure 19 (e)). The best result achieved when we applied only case 1 and 3 and the worst accuracy gained from utilizing all cases in class E.

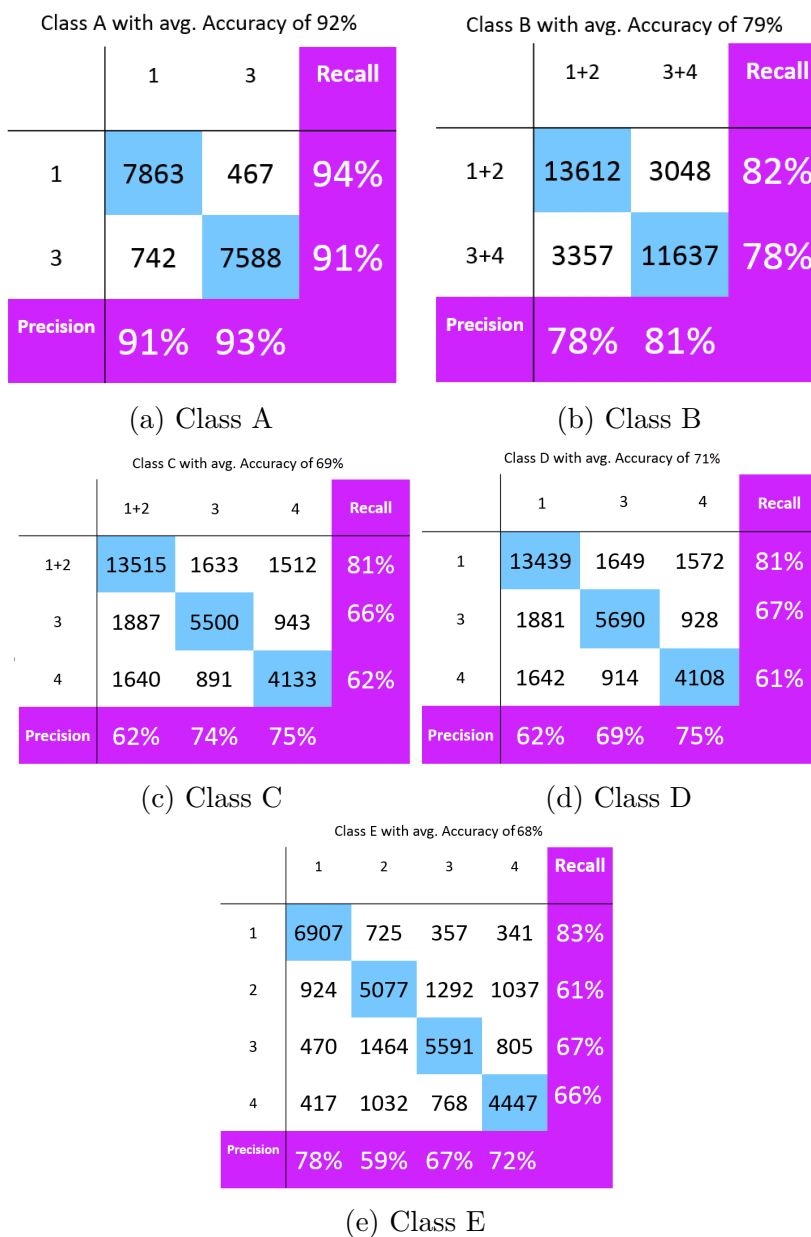

Figure 19: Confusion matrices of different classes conducted for human presence detection recognized by KNN classifier for all four cases have been indicated in this figure. Average accuracy is also shown for each case.

6 Conclusion

This work has presented the potential usage of OFDM waveforms in 5G system as valuable tools to develop improvised motion detection systems. This concept is of significant interest in many applicative fields such as wellness and fitness monitoring and health-care perception from mobile phones. Experimental results have demonstrated a reliable performance for both activity detection and classification of data. Real hardware experiments were conducted to compare the performance of two body-worn accelerometer device and radio frequency signals while using multi-carrier waveforms (ofdm) between transmitter and receiver. We conclude that the distinction of simultaneously conducted activities from multiple subjects is feasible with exploiting radio frequency signal, accelerometer measurements and simple data processing algorithms.

We reviewed literature in the beginning from RF modalities, inertial acceleration sensing and 5G systems main characteristics to compare the results achieved in this thesis to the state-of-the-art. Then, we conducted extensive experiments in typical indoor environments including a corridor for walking speed analysis and two work places for presence detection evaluation. All data process has been done in MATLAB application with support of signal processing toolbox and Classification Learner tool. We process the OFDM values with multiple carriers both for walking speed and presence detection in five scenarios including various number of carriers.

We evaluated the results in real environments achieving accurate detection capability reaching 92.8% and 95% in two study cases respectively. The results showed promising performance in terms of accuracy for ubiquitous motion detection in cellular systems and from IoT-class devices. The results show high potential of the technology for improved and ubiquitous motion detection. In particular, we demonstrated excellent walking speed recognition accuracy considering three respective classes. The accuracy is comparable or superior to accelerometer-based walking speed detection. We observe that, while accuracy in walking speed recognition has already been nearly at level with inertial sensing approaches, exploiting further carriers over a larger bandwidth combined with low noise in the signal reception have the potential to achieve comparable or even better recognition accuracy. By exploitation of five cases of RF analysis from Walking speed, we achieved the best accuracy when we applied only 26 carriers for data process.

Future steps include the consideration of more fine-grained activities and gestures with a further advanced prototype system, then also exploiting Multiple-In-Multiple-Out (MIMO) transmission utilizing multiple antennas. We also aim to apply higher frequency up to 15 GHz and evaluate activity detection performance of system since the prototype 5G system is capable to operate at high frequencies. In addition, we will also analyze recognition capabilities of proposed system in various environments like different indoor work places and various human activities and outdoor locations and with longer distances between Tx and Rx to evaluate the results.

References

- [1] Li, Rongpeng, et al. Intelligent 5G: When Cellular Networks Meet Artificial Intelligence. *IEEE Wireless Communications*, 2017
- [2] Savazzi, Stefano, et al. Device-Free Radio Vision for Assisted Living: Leveraging wireless channel quality information for human sensing. *IEEE Signal Processing Magazine* 33.2 (2016): 45-58.
- [3] Pu Q, Gupta S, et al. Whole-home gesture recognition using wireless signals. *In Proceedings of the 19th annual international conference on Mobile computing & networking* 2013 Sep 30 (pp. 27-38). ACM.
- [4] Fadel Adib and Dina Katabi. See through walls with WiFi! *SIGCOMM Comput. Commun. Rev.* 43,4, 2013.
- [5] Shi, Stephan Sigg, et al. Activity recognition from radio frequency data: Multi-stage recognition and features. *Vehicular Technology Conference (VTC Fall) 2012 IEEE*. IEEE, 2012.
- [6] Mogensen, Preben, et al. 5G small cell optimized radio design. *Globecom Workshops (GC Wkshps), 2013 IEEE*. IEEE, 2013.
- [7] Wang, Wei, et al. Understanding and modeling of wifi signal based human activity recognition. *Proceedings of the 21st annual international conference on mobile computing and networking*. ACM, 2015.
- [8] Zhou, Zimu, et al. Omnidirectional coverage for device-free passive human detection. *IEEE Transactions on Parallel and Distributed Systems* 25.7 (2014): 1819-1829.
- [9] Woyach, Kristen, et al. Sensorless sensing in wireless networks: Implementation and measurements. *Modeling and Optimization in Mobile, Ad Hoc and Wireless Networks, 2006 4th International Symposium on*. IEEE, 2006.
- [10] S. Sigg, S. Shi, et al. Leveraging RF-channel fluctuation for activity recognition: active and passive systems, continuous and RSSI-based signal features. *In Proceedings of MoMM, Vienna Austria, Dec. 2013*.
- [11] S. Sen, B. Radunovic, et al. Spot localization using phy layer information. *In Proceedings of 10th Annual International Conference on Mobile Systems, Applications, and Services UK*, Jun. 2012.
- [12] Huang, Xiaoxia, and Mingwei Dai. Indoor Device-Free Activity Recognition Based on Radio Signal. *IEEE Transactions on Vehicular Technology* (2016).
- [13] S. Sigg, Ulf Blanke, et al. The telepathic phone: Frictionless activity recognition from wifi-rssi. *Pervasive Computing and Communications (PerCom), 2014 IEEE International Conference on*. IEEE, 2014.

- [14] Abdelnasser, Heba, et al. Wigest: A ubiquitous wifi-based gesture recognition system. *Computer Communications (INFOCOM), 2015 IEEE Conference*. IEEE, 2015.
- [15] D. Huang, R. Nandakumar, and S. Gollakota. Feasibility and limits of Wi-Fi imaging. *In Proceedings of ACM SenSys*, pages 266–279, 2014.
- [16] K. R. Joshi, S. S. Hong, and S. Katti. Pinpoint: Localizing interfering radios. *In Proceedings of Usenix NSDI* pages 241–253, 2013.
- [17] B. Kellogg, V. Talla, and S. Gollakota. Bringing gesture recognition to all devices. *In Proceedings of Usenix NSDI*, 2014.
- [18] Al-qaness, Mohammed Abdulaziz Aide, and Fangmin Li. WiGeR: WiFi-based gesture recognition system. *ISPRS International Journal of Geo-Information* 5.6 (2016): 92.
- [19] F. Adib, Z. Kabelac, and D. Katabi. Multi-person motion tracking via RF body reflections. *In Proceedings of Usenix NSDI*, 2015.
- [20] F. Adib, Z. Kabelac, et al. 3D tracking via body radio reflections. *In Proceedings of Usenix NSDI*, 2013.
- [21] B. Lyonnet, C. Ioana, and M. G. Amin. Human gait classification using microdoppler time-frequency signal representations. *In Proceedings of IEEE Radar Conference*, pages 915–919, 2010.
- [22] P. Van Dorp and F. Groen. Feature-based human motion parameter estimation with radar. *IET Radar, Sonar & Navigation* , 2(2):135–145, 2008.
- [23] Wang, Yuxi, et al. Wifall: Device-free fall detection by wireless networks. *IEEE Transactions on Mobile Computing* 16.2 (2017): 581-594.
- [24] D. Halperin, W. Hu, et al. Tool release: Gathering 802.11n traces with channel state information. *ACM SIGCOMM CCR*, 41(1):53 , 2011.
- [25] S. Sen, J. Lee, et al. Avoiding multipath to revive inbuilding WiFi localization. *In Proceeding of ACM MobiSys*, pages 249–262, 2013.
- [26] Z. Yang, Z. Zhou, and Y. Liu. From RSSI to CSI: Indoor localization via channel response. *ACM Computing Surveys*, 46(2):25, 2013.
- [27] Z. Zhou, Z. Yang, et al. Towards omnidirectional passive human detection. *In Proceedings of IEEE INFOCOM*, pages 3057–3065, 2013.
- [28] C. Han, K. Wu, et al. Wifall: Device-free fall detection by wireless networks. *In Proceedings of IEEE INFOCOM*, pages 271–279, 2014.
- [29] W. Xi, J. Zhao, et al. Electronic frog eye: Counting crowd using WiFi. *In Proceedings of IEEE INFOCOM*, 2014.

- [30] Wang, Wei, et al. Wang, Wei, et al. Understanding and modeling of wifi signal based human activity recognition. *Proceedings of the 21st annual international conference on mobile computing and networking. ACM, 2015.*
- [31] Wang, Yan, et al. WE-eyes: device-free location-oriented activity identification using fine-grained wifi signatures. *Proceedings of the 20th annual international conference on Mobile computing and networking. ACM, 2014.*
- [32] G. Wang, Y. Zou, et al. We can hear you with Wi-Fi! *In Proceedings of ACM MobiCom, 2014.*
- [33] Wu, Kaishun, et al. CSI-based indoor localization. *IEEE Transactions on Parallel and Distributed Systems 24.7 (2013): 1300-1309.*
- [34] Mrazovac, Bojan, et al. Reaching the next level of indoor human presence detection: An rf based solution. *Telecommunication in Modern Satellite, Cable and Broadcasting Services (TELSIKS), 2013 11th International Conference on. Vol. 1. IEEE, 2013.*
- [35] Shannon, C.E. A mathematical theory of communication *The Bell System Tech. Journal, vol. 27, pp. 379-423/623-656, 1948.*
- [36] Kosba, Ahmed E., et al. Robust WLAN device-free passive motion detection. *Wireless Communications and Networking Conference (WCNC), 2012 IEEE. IEEE, 2012.*
- [37] Atallah, L., et al. Sensor positioning for activity recognition using wearable accelerometers. *IEEE Trans. Biomed. Circuits Syst.* 2011, 5, 320–329.
- [38] Cleland, Ian, et al. Optimal placement of accelerometers for the detection of everyday activities. *Sensors 13.7 (2013): 9183-9200.*
- [39] Yang, Shuozhi, and Qingguo Li. Inertial sensor-based methods in walking speed estimation: A systematic review. *Sensors 12.5 (2012): 6102-6116.*
- [40] Sabatini, A. Computational Intelligence for Movement Sciences: Neural Networks, Support Vector Machines and Other Emerging Techniques. *Idea Group Inc.: Hershey, PA, USA, 2006; pp. 70–100.*
- [41] Song, Y., Shin, S., et al. Speed estimation from a tri-axial accelerometer using neural networks. *In Proceedings of 29th Annual International Conference of the IEEE Engineering in Medicine and Biology Society, Lyon, France , 23–36 August 2007; pp. 3224–3227.*
- [42] Aminian, K., Robert, et al. Estimation of speed and incline of walking using neural network. *IEEE Transa. Instrum. Meas.* 1995, 44, 743–746.

- [43] Yeoh, W., Pek, I., et al. Ambulatory monitoring of human posture and walking speed using wearable accelerometer sensors. *In Proceedings of 30th Annual International Conference of the IEEE Engineering in Medicine and Biology Society*, Vancouver, BC, Canada, 20–24 August 2008; pp. 5184–5187.
- [44] Martin, S., van Asseldonk, et al. Ambulatory estimation of foot placement during walking using inertial sensors. *J. Biomech.* 2010, 43, 3138–3143.
- [45] P.Esling, C. Agon, Time-series data mining *ACM Comput.Surv.*45 (1)(2012)12.
- [46] Liu, Li, et al. Complex activity recognition using time series pattern dictionary learned from ubiquitous sensors. *Information Sciences* 340 (2016): 41-57.
- [47] Shafi, Mansoor, et al. 5G: A Tutorial Overview of Standards, Trials, Challenges, Deployment and Practice. *IEEE Journal on Selected Areas in Communications* (2017).
- [48] E. G. Larsson et al. Massive MIMO for next generation wireless systems *IEEE Commun. Mag.*, vol. 52, no. no.2, pp. 186–195, February 2014.
- [49] Rusek, Fredrik, et al. Scaling up MIMO: Opportunities and challenges with very large arrays *IEEE Signal Processing Magazine*, vol. 30, no. 1, pp. 40–60, Jan 2013.
- [50] Raschkowski, L. , et al. Directional propagation measurements and modeling in an urban environment at 3.7 GHz. *Signals, Systems and Computers, 2016 50th Asilomar Conference on. IEEE, 2016.*
- [51] Zhang, Xinchun, et al.. Downlink cellular network analysis with multi-slope path loss models *IEEE Transactions on Communications*, vol. 63, no. 5, pp. 1881–1894, May 2015.
- [52] Long LL III, Srinivasan M. Walking, running, and resting under time, distance, and average speed constraints:optimality of walk–run–rest mixtures. *JRSocInterface*10:20120980,2013 <http://dx.doi.org/10.1098/rsif.2012.0980>
- [53] <https://play.google.com/store/apps/details?id=de.unima.ar.collector>
- [54] Berardinelli, Gilberto, et al. On the potential of OFDM enhancements as 5G waveforms. *Vehicular Technology Conference (VTC Spring), 2014 IEEE 79th. IEEE, 2014.*
- [55] Pun M, Morelli M, Kuo C. Multi-Carrier Techniques For BroadbandWireless Communications: A Signal Processing Perspectives. *Imperial College Press: 57 Shelton Street Covent Garden London WC2H 9HE, 2007.*
- [56] Van Waterschoot T, Le Nir V, et al. Analytical expressions for the power spectral density of CP-OFDM and ZP-OFDM signals. *Signal Processing Letters, IEEE* 2010; 17(4): 371–374.

- [57] Loulou, AlaaEddin, and Markku Renfors. Enhanced OFDM for fragmented spectrum use in 5G systems. *Transactions on Emerging Telecommunications Technologies* 26.1 (2015): 31-45.
- [58] Michailow N, Matthe M, et al. Generalized frequency division multiplexing for 5th generation cellular networks. *Communications, IEEE Transactions on* 2014; 62(9): 3045-3061.
- [59] RF signals. [Online]. Available: <http://etutorials.org/Networking/wn/Chapter+3.+Radio+Frequency+and+Light+Signal+Fundamentals+The+Invisible+Medium/Understanding+RF+Signals/>
- [60] Fading. [Online]. Available: <https://en.wikipedia.org/wiki/Fading>
- [61] Terng-Yin Hsu and Chen-Yi Lee Effects of shadowing, multipath fading, antenna diversity in DS/CDMA for cellular mobile radio with reverse-link power control. *GLOBECOM 97. IEEE Global Telecommunications Conference. Conference Record, Phoenix, AZ, 1997, pp. 894-898 vol.2.*
- [62] Wang, Shuangquan, and Gang Zhou. A review on radio based activity recognition. *Digital Communications and Networks* 1.1 (2015): 20-29.
- [63] Cassioli, Dajana, and Nikola Rendeovski. A statistical model for the shadowing induced by human bodies in the proximity of a mmWaves radio link. *Communications Workshops (ICC), 2014 IEEE International Conference on.* IEEE, 2014.
- [64] Klassen, Tara D., et al. Stepping Up" Activity Poststroke: Ankle-Positioned Accelerometer Can Accurately Record Steps During Slow Walking. *Physical therapy* 96.3 (2016): 355.
- [65] Incel, Ozlem Durmaz, et al. A review and taxonomy of activity recognition on mobile phones. *BioNanoScience* 3.2 (2013): 145-171.
- [66] Khan, W.Z., Xiang, Y., et al. Mobile phone sensing systems: A survey. *IEEE Commun. Surv. Tutor.* 2013, 15, 402-427.
- [67] Bieber, G.,Fernholz, N., et al. Smart Watches for Home Interaction Services. *In HCI International 2013-Posters' Extended Abstracts; Springer: Berlin/Heidelberg, Germany, 2013; pp. 293-297.*
- [68] Mortazavi, B.J., Pourhomayoun, et al. Determining the single best axis for exercise repetition recognition and counting on smartwatches. *In Proceedings of the 2014 11th International Conference on Wearable and Implantable Body Sensor Networks (BSN), Zurich, Switzerland, 16-19 June 2014; pp. 33-38.*
- [69] Moncada-Torres, A., et al. Activity classification based on inertial and barometric pressure sensors at different anatomical locations. *Physiological measurement* 35.7 (2014): 1245.

- [70] Shoaib, Muhammad, et al. Complex human activity recognition using smart-phone and wrist-worn motion sensors. *Sensors* 16.4 (2016): 426.
- [71] Parkka, J., et al. Activity classification using realistic data from wearable sensors. *IEEE Trans. Inf. Technol. Biomed.* 2006, 10, 119–128.
- [72] Rappaport, T.S. Wireless Communications, Principles and Practice. *Prentice Hall: Bergen, NJ, USA, 1996.*
- [73] Tan, Kun, et al. Fine-grained channel access in wireless LAN. *ACM SIGCOMM Computer Communication Review. Vol. 40. No. 4. ACM, 2010.*
- [74] Gurbuz, Sevgi Zubeyde, et al. Micro-Doppler-based in-home aided and unaided walking recognition with multiple radar and sonar systems. *IET Radar, Sonar Navigation* (2016).
- [75] Y. Kim and H. Ling Human activity classification based on micro-Doppler signatures using a support vector machine *IEEE Trans. Geosci. Remote Sens.*, vol. 47, no. 5, pp. 13281337, 2009.
- [76] Fioranelli, Francesco, et al. Classification of unarmed/armed personnel using the NetRAD multistatic radar for micro-Doppler and singular value decomposition features. *IEEE Geoscience and Remote Sensing Letters*, vol. 12, iss. 9, Sept. 2015, pp. 1933 – 1937.
- [77] Sekine, M., Tamura, et al. Classification of Walking Pattern Using Acceleration Waveform in Elderly People. *In Proceedings of the 22nd Annual IEEE International Conference of the Engineering in Medicine and Biology Society, Chicago, MI, USA, 23–28 July 2000; Volume 2, pp. 1356–1359.*
- [78] Kawahara, H.S.Y., et al. Context-Aware Collaborative Filtering Algorithm for Real World Oriented Content Delivery Service. *In Proceedings of 7th International Conference Ubiquitous Computing, Tokyo, Japan, 11–14 September 2005.*
- [79] IEEE Standard for Information Technology-Telecommunications and Information Exchange Between Systems-Local and Metropolitan Area Networks-Specific Requirements—Part 11: Wireless LAN Medium Access Control (MAC) and Physical Layer (PHY) Specifications, clause 17. *IEEE Std 802.11-2007 (Revision of IEEE Std 802.11-1999), 2007, pp. 591–635.*
- [80] Cross Validation. [Online]. Available: [https://en.wikipedia.org/wiki/Cross-validation_\(statistics\)](https://en.wikipedia.org/wiki/Cross-validation_(statistics))
- [81] USRP 2932. [Online]. Available: <http://www.ni.com/datasheet/pdf/en/ds-355>
- [82] USRP X310. [Online]. Available: <https://www.ettus.com/product/details/X310-KIT>

- [83] KNN algorithm. [Online]. Available: <http://www.kdnuggets.com/2016/01/implementing-your-own-knn-using-python.html>
- [84] KNN algorithm [Online]. Available: https://en.wikipedia.org/wiki/K-nearest_neighbors_algorithm
- [85] Export. [Online]. Available: <https://se.mathworks.com/help/stats/export-classification-model-for-use-with-new-data.html>
- [86] Classification. [Online]. Available: <https://se.mathworks.com/help/stats/train-classification-models-in-classification-learner-app.html>
- [87] Sensor Data Collector. [Online]. Available: <https://play.google.com/store/apps/details?id=de.unima.ar.collector>
- [88] Radar [Online]. Available: https://en.wikipedia.org/wiki/Radar_signal_characteristics.

A Appendix

A.1 Classification Learner application in MATLAB

The Classification Learner app trains models to classify data. Using this app, you can explore supervised machine learning using various classifiers. You can explore your data, select features, specify validation schemes, train models, and assess results. You can perform automated training to search for the best classification model type, including decision trees, discriminant analysis, support vector machines, logistic regression, nearest neighbors, and ensemble classification. You can perform supervised machine learning by supplying a known set of input data (observations or examples) and known responses to the data (e.g., labels or classes). You use the data to train a model that generates predictions for the response to new data. To use the model with new data, or to learn about programmatic classification, you can export the model to the workspace or generate MATLAB code to recreate the trained model. Following list describes a brief tutorial of how to run Classification Learner in MATLAB [86].

A.1.1 Train Classification Models

- It has an option of automatically train multiple classifiers which you can quickly try a selection of models.
- It is also possible to train individual classifiers, check Manual Classifier Training.
 - On the Apps tab, in the Math, Statistics and Optimization group, click Classification Learner.
 - Click New Session and select data from the workspace or from file. We also need to define a response variable and variables to use as predictors. See Select Data and Validation for Classification Problem.
 - On the Classification Learner tab, in the Model Type section, there is another option of employ all classifiers with clicking on All Quick-To-Train button.
 - Click Train (Figure A2).
A selection of model types appears in the History list. When they finish training, the highest accuracy score is highlighted in a box (Figure A3).
 - Click models in the history list to explore results in the plots.

A.1.2 Choose Validation Scheme

Validation scheme is required to analyze and process the data, which you can see on the right side of the Figure A1 and it consists of three main parts: Cross validation, Hold out validation and No validation. The main reason of validation is protection against overfitting and miscalculations [86].

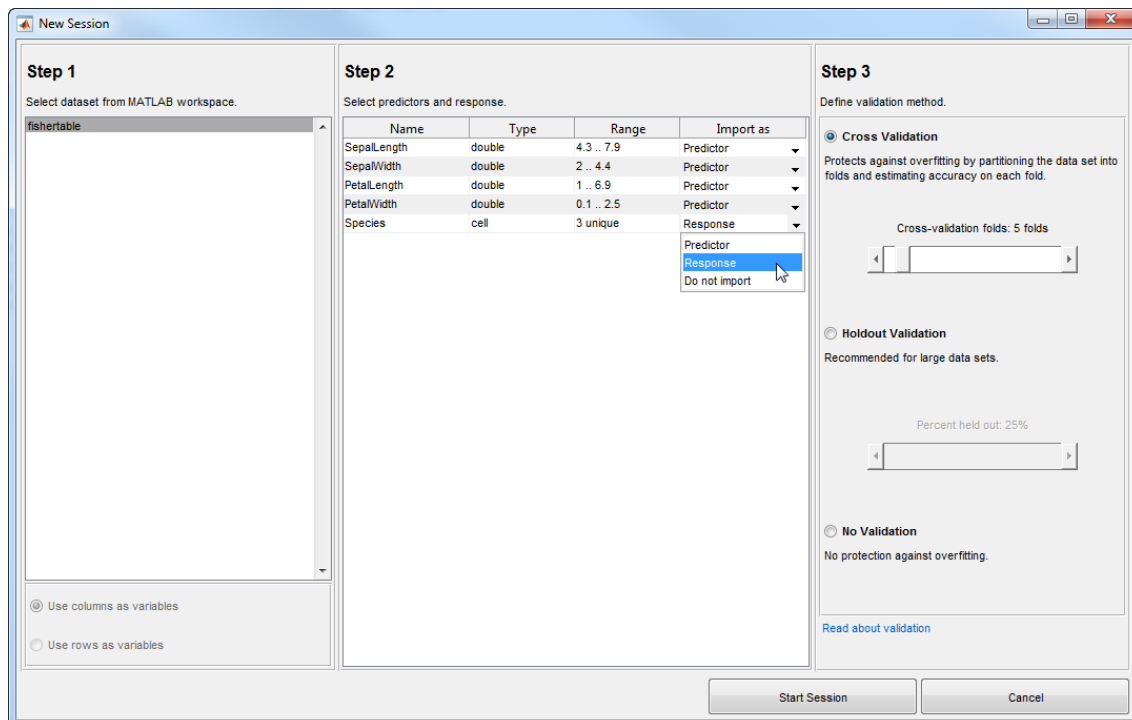

Figure A1: Setup Classification Dialog [86].

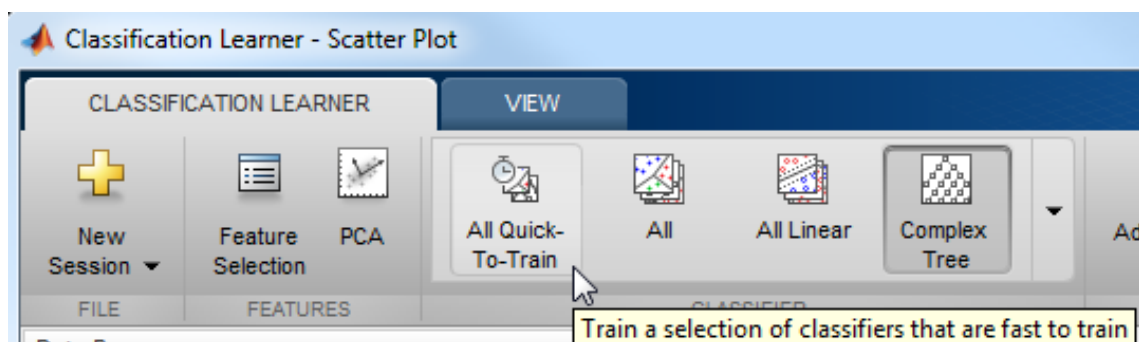

Figure A2: Train classifiers [86].

▼ History		
1	☆ Tree Complex Tree	Accuracy: 69.1% 2/2 features
2	☆ Tree Medium Tree	Accuracy: 64.0% 2/2 features
3	☆ Tree Simple Tree	Accuracy: 58.7% 2/2 features
4	☆ KNN Fine KNN	Accuracy: 74.5% 2/2 features
5	☆ KNN Medium KNN	Accuracy: 71.6% 2/2 features
6	☆ KNN Coarse KNN	Accuracy: 56.8% 2/2 features
7	☆ KNN Cosine KNN	Accuracy: 58.4% 2/2 features
8	☆ KNN Cubic KNN	Accuracy: 71.9% 2/2 features
9	☆ KNN Weighted KNN	Accuracy: 77.5% 2/2 features

Figure A3: History of trained classifiers with their accuracies [86].

- Cross-Validation: Select a number of folds (or divisions) to divide the data set using the slider control.

If you choose k folds, then the app:

- Partitions the data into k disjoint sets or folds.
- For each fold:
 - * Trains a model using the out-of-fold observations.
 - * Assesses model performance using in-fold data.
- Calculates the average test error over all folds.

This method gives a good estimate of the predictive accuracy of the final model trained with all the data. It requires multiple fits but makes efficient use of all the data, so it is recommended for small data sets.

- Holdout Validation: Select a percentage of the data to use as a test set using the slider control. The app trains a model on the training set and assesses its performance with the test set. The model used for validation is based on only a portion of the data, so Holdout Validation is recommended only for large data sets. The final model is trained with the full data set.
- No Validation: No protection against over fitting. The app uses all of the data for training and computes the error rate on the same data. Without any test data, you get an unrealistic estimate of the model's performance on new data. That is, the training sample accuracy is likely to be unrealistically high, and the predictive accuracy is likely to be lower.

A.1.3 Compare and Improve Classification Models

The Figure A4 shows the application with a history list containing various classifier types. It shows the scatter plot of an example which each class is identified with specific color. On the top right of figure, we can choose to see the data after or before predicted model. In addition, we have access to see only incorrect or correct values on scatterplot as well. There is an option of selecting , PCA (reduce dimensionality), or new parameter settings improve the model and try training all model types with the new settings. By clicking feature selection, we can select the best model in the history and changing different features to choose the best combination of them [86].

A.1.4 Export Classification Model to Predict New Data

There is another option in Classification Learner tool in MATLAB, which we can export the trained model structure to work space of MATLAB to make further predictions manually, and having a chance to changes the variables accordingly. The exported structure consists of classification object and a function for prediction. There is a function to use the exported classifier to make predictions for new data, T, as follows [85]:

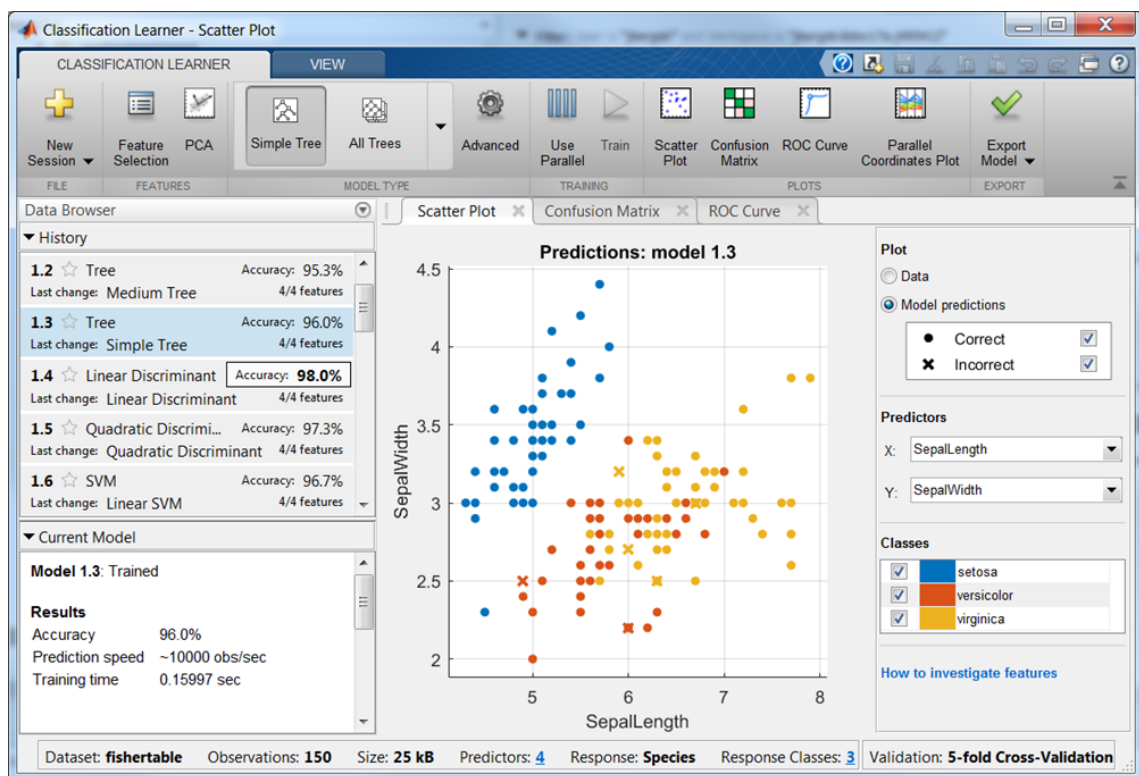

Figure A4: History of trained classifiers with their accuracies [86].

`yfit = C.predictFcn(T)`

where `C` is the name of variable, e.g., `trainedModel` of `knn` algorithm (we only can export one trained classifiers). This is important to match the data type as the original trained model (matrix or table) and it is also important to ensure the data (`T`) contains the same predictor names as training data. The `predictFcn` ignores additional variables in tables. In addition, if a matrix is being trained, it must contain the same predictor columns or rows as training data, in the same order and format. We can also extract the classification object from the exported structure for further analysis (e.g., `trainedModel.ClassificationSVM`, `trainedModel.ClassificationTree`, etc., depending on your model type) [85]

A.2 k-Nearest Neighbors Algorithm

K-Nearest-Neighbors (KNN) is an algorithm that classifies data sets based on their similarity with neighbors. `K` is the number of data set items utilized for the classification. The algorithm consists of two main objectives: A distance measure to determine the similarities and identifying value of `K` [84].

K-Nearest-Neighbors (KNN) is an algorithm that classifies data sets based on their similarity with neighbors. `K` is the number of data set items utilized for the classification. The algorithm consists of two main objectives: A distance measure to determine the similarities and finding distance between any two pairs, identification of value of `K` to find the nearest neighbors based on distances of any two points and giving the value on a class labels based on neighboring list(see Figure A5) [83].

The neighbors are taken from a set of objects for which the class (for `kNN` classification) or the object property value (for `kNN` regression) is known. This can be thought of as the training set for the algorithm, though no explicit training step is required. For the given attributes: $A = X_1, X_2, \dots, X_D$, where `D` is the dimension of the data, prediction of the corresponding classification is group of $G = Y_1, Y_2, \dots, Y_n$ is needed by using the proximity metric over `K` items in `D` dimension that defines the similarities of attributes [84].

They are three main advantages of KNN algorithms. Firstly, it can be applied to the data from any distribution; for example, data does not have to be separable with a linear partition. Secondly, it is very simple and reliable algorithm and finally, it is a handful classification for big size data. In the other hand, one of the drawbacks is being dependent to `K` value for classifications; also, it does not exploit training stage and all the work is done during the test stage [84].

A.3 Cross Validation

It is in a way that the data is broken into partitions and some sub groups are chosen for training and other partitions for testing sets and it has an advantage of avoiding overlapping test sets and not cause the entire data set to be used while training data [80].

kNN Algorithm

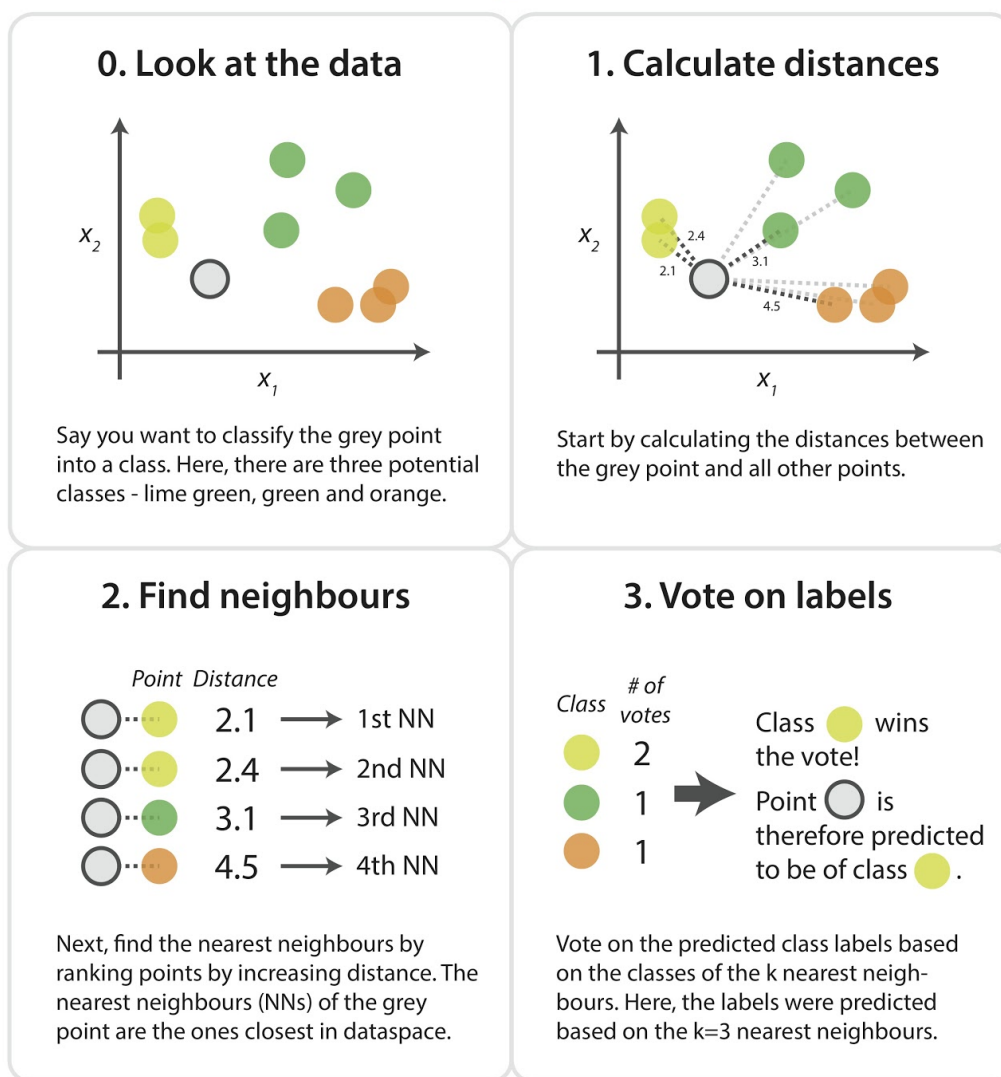

Figure A5: An example of KNN classification [83].

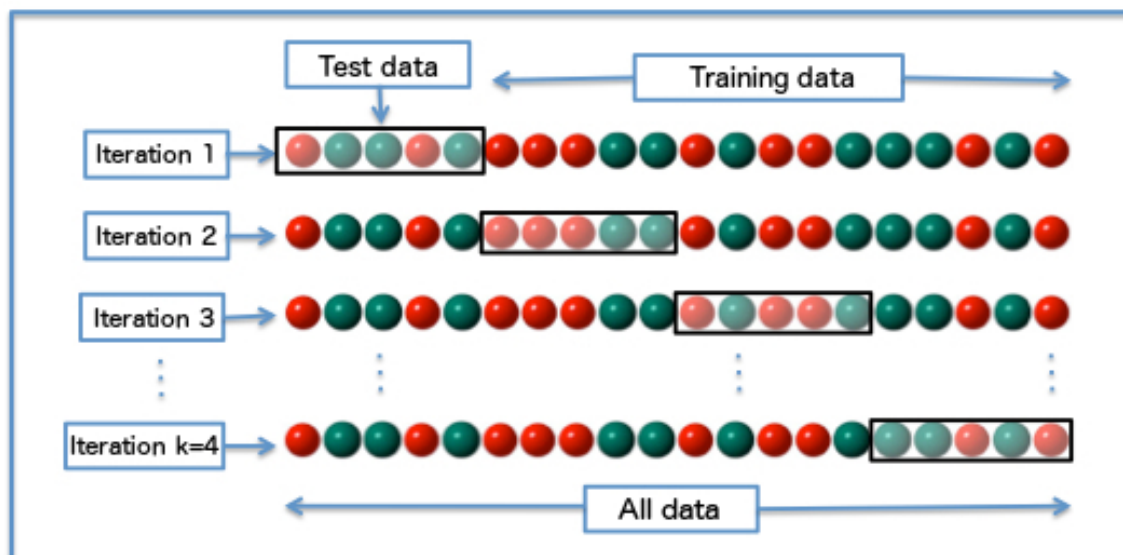

Figure A6: An example of K-fold-cross-validation [80].

The **holdout method** It is the simple way which data set is divided to only two partitions including the training and testing sets. Training set is used to train the classifier and Test set is used to estimate the error rate of the trained classifier [80].

K-fold cross validation The data set is divided into k partitions or folds, and the holdout method is repeated k times. Each time, one of the k folds is used as the test set and the other $k-1$ subsets are for training set. The advantage of this method is that every data point is only one time in a test set and gets to be in a training set $k-1$ times [80].

Leave-one-out cross validation It is another type of K-fold cross validation, which the data set, is split into N partitions of size 1. So that each partition is used systematically for testing exactly once whereas the remaining partitions are used for training (Figure A6) [80].

A.4 USRP, Software Defined Radio Device

NI USRP-292x and 293x software defined radio transceivers are deployed for wireless communications teaching and research using radio frequency signals across a wide range of frequencies with up to 20 MHz of real-time bandwidth and plug-and-play MIMO support and mostly used for environmental perception. these devices are used for rapid prototyping applications such as record and playback, physical layer communication, spectrum monitoring, and more. These version of USRP enables a broad range of RF applications covering standards like ZigBee, WiFi (802.11) and etc [81].

A.4.1 USRP X310

USRP X300 and X310 are the updated advanced version of USRPs which are employed for next generation wireless communications systems (Cellular/WiFi). Which have many benefits like high performance by deploying up to 160MHz bandwidth and DC covers up to 6 GHz. They also utilize Multiple High-Speed Interface options like extended bandwidth and lower latency applications such as PHY/MAC research. In addition, user can add additional features that can add to device as extra daughterboards to provide high-accuracy frequency reference and synchronization [82].