

ISSN: 2088-6799



# PROCEEDINGS

## International Seminar

LANGUAGE MAINTENANCE AND SHIFT III

July 2–3, 2013

Revised Edition



Master Program in Linguistics, Diponegoro University  
in Collaboration with  
Balai Bahasa Provinsi Jawa Tengah

ISSN: 2088-6799



# PROCEEDINGS

## International Seminar LANGUAGE MAINTENANCE AND SHIFT III

July 2–3, 2013

Revised Edition



**Editors:**  
Jee Sun Nam  
Agus Subiyanto  
Nurhayati

Master Program in Linguistics, Diponegoro University  
in Collaboration with  
Balai Bahasa Provinsi Jawa Tengah

## **Editors' Note**

In the international seminar on Language Maintenance and Shift III, there are some new issues. First, the committee changes the previous theme into "Investigating Local Wisdom through Indigenous Language". Through the new theme, the committee invites language practitioners to discuss the problems concerning the importance of maintaining indigenous languages because the languages function as a means of expressing local wisdom. Second, the seminar uses the new label, LAMAS, the acronym which was proposed by Prof. Dr. Bambang Kaswanti Purwo in the previous seminar, to make the participants easily remember it. Third, most of the keynote speakers come from various institutions. Those are Dr. Johnny Tjia (Summer Institute of Linguistics, Indonesia-International), Prof. Jee Sun Nam, Ph.D (Hankuk University of Foreign Studies, Korea), Prof. Dr. Mahsun, M.S. (Badan Pengembangan dan Pembinaan Bahasa, Jakarta, Indonesia), Prof. Dr. Bambang Kaswanti Purwo (Atma Jaya Catholic University, Jakarta-Indonesia), Prof. Dr. I Dewa Putu Wijana (Gadjah Mada University, Yogyakarta, Indonesia), Prof. Drs. Ketut Artawa, M.A., Ph.D (Udayana University, Denpasar, Indonesia), and Dr. Suharno, M.Ed. (Diponegoro University, Semarang, Indonesia).

There are 113 participants who present the papers covering various topic areas. Those are 38 papers on sociolinguistics, 14 papers on morphology, 13 papers on applied linguistics, 8 papers on anthropological linguistics, 8 papers on discourse analysis, 8 papers on cognitive linguistics, 7 papers on ethnography of communication, and 7 papers on computational linguistics.

We would like to thank the seminar committee for putting together the seminar that gave rise to this collection of papers. Thanks also go to the head and secretary of the Master Program in Linguistics Diponegoro University, without whom the seminar would not have been possible.

## **Editors' Note for Revised Edition**

There are some changes in this revised edition. First, we enclose the article by Prof. Jee Sun Nam, Ph.D entitled "Retrieving Local Wisdom in Korean with the Support of Corpus Processing Software" on page 555. Second, we delete the article by Yusup Irawan 'Tiga Syarat Menuju Fonetik Modern' as he cancelled his status as a participant. These changes have an impact on the change of table of contents.

## CONTENTS

<b>EDITORS' NOTE</b> .....	i
<b>EDITORS' NOTE FOR REVISED EDITION</b> .....	ii
<b>CONTENTS</b> .....	iii
<b>SCHEDULE OF THE INTERNATIONAL SEMINAR “LAMAS III”</b> .....	xiv
ISU KEBERTAHANAN DALAM USAHA PENCAGARAN BAHASA <i>Johnny Tjia</i> .....	1
KEARIFAN LOKAL: PERTARUNGAN ANTARA TEKS IDEAL DAN TEKS SOSIAL <i>Ketut Artawa</i> .....	15
KEBANGGAAN BERBAHASA SEBAGAIMANA YANG TEREKSEKSI DALAM WACANA TEKA-TEKI <i>I Dewa Putu Wijana</i> .....	26
SYNTACTICO-SEMANTIC CLASSIFICATION OF SENTIMENT WORDS IN THE ELECTRONIC DICTIONARY DECO <i>Won-Fill Jung, Eunhae Son, Jee-Sun Nam, Jaemog Song</i> .....	31
INCORPORATING LOCAL WISDOM INTO ENGLISH LANGUAGE TEACHING (ELT) <i>Suharno</i> .....	37
THE WEALTH CONCEPT OF JAVANESE SOCIETY: ANTHROPOLOGICAL LINGUISTICS APPROACH IN CUBLAK-CUBLAK SUWENG FOLKSONG <i>Aan Setyawan</i> .....	42
BAHASA PERMOHONAN DI DALAM TRADISI KLIWONAN DI “SUMUR BERKAH” DESA WONOYOSO KABUPATEN PEKALONGAN <i>Abadi Supriatin</i> .....	47
PENGGUNAAN BAHASA DAERAH DALAM IKLAN LAYANAN MASYARAKAT SEBAGAI ALAT PEMERTAHANAN BUDAYA BANGSA (STUDI KASUS DI KOTA SERANG PROVINSI BANTEN) <i>Ade Husnul Mawadah</i> .....	51
MULTICULTURAL ENGLISH CURRICULUM ACCOMODATING LOCAL WISDOM <i>Agnes Widyaningrum</i> .....	56
TINDAK ILOKUSI PROPAGANDA CAGUB-CAWAGUB JAWA TENGAH PERIODE 2013-2018 <i>Agus Edy Laksono</i> .....	61

MOTION-DIRECTION SERIAL VERB CONSTRUCTIONS IN JAVANESE: A LEXICAL-FUNCTIONAL APPROACH <i>Agus Subiyanto</i> .....	65
DO BANJARESE WOMEN AND MEN SPEAK DIFFERENTLY? <i>Agustina Lestary</i> .....	70
STUDENTS’ MOTIVES IN SWITCHING FROM ENGLISH TO INDONESIAN OR JAVANESE IN A FOREIGN LANGUAGE SETTING <i>Almira Irwaniyanti Utami</i> .....	74
THE IMPORTANCE OF NOTICING IN IMPROVING EFL STUDENTS’ WRITING SKILLS <i>Amrih Bekti Utami</i> .....	79
FENOMENA SOSIOLINGUISTIK BAHASA JAWA PESISIR SEBAGAI CERMIN KEARIFAN LOKAL <i>Anandha</i> .....	82
ALIH KODE DAN CAMPUR KODE PADA CERAMAH BUDAYA EMHA AINUN NAJIB <i>Anang Febri Priambada</i> .....	87
A LYRIC’S WORTH IN GESANG’S “CAPING GUNUNG” <i>Ariya Jati</i> .....	92
KEARIFAN LOKAL MITIGASI BENCANA DALAM TRADISI SASTRA LISAN NUSANTARA <i>Asih Prihandini and N. Denny Nugraha</i> .....	97
JAVANESE VIEW ON EDUCATION: AN ETNOLINGUISTIC STUDY <i>Atin Kurniawati</i> .....	102
TRANSLATION UNIT IN THE TRANSLATION OF AL-QURAN INTO INDONESIA <i>Baharuddin</i> .....	106
THE IDENTITY OF JAVANESE PEOPLE (A STUDY ON SELAMATAN IN EAST JAVA, ETHNOLINGUISTICS PERSPECTIVE) <i>Bambang Hariyanto</i> .....	111
METAPHORICAL SWITCHING: A LINGUISTIC REPERTOIRE OF MUSLIM JAVANESE PRIESTS <i>Bernadetta Yuniati Akbariah</i> .....	115

THE INFLUENCE OF TRADITIONAL MAIDS’ JAVANESE TO CHILDREN’S LANGUAGE (A CASE STUDY AT KAMPUNG KENTENG, KEJIWAN, WONOSOBO) <i>Christina</i> .....	120
LOCAL WISDOM IN JAVANESE PROVERBS (A COGNITIVE LINGUISTIC APPROACH) <i>Deli Nirmala</i> .....	124
JAVANESE EXPRESSIONS AS LOCAL WISDOM MANIFESTATION <i>Dian Swastika</i> .....	129
PEKALONGAN DIALECT IN RAPROX BAND LYRICS <i>Didik Santoso</i> .....	133
THEMATIC STRUCTURE SHIFT FOUND IN ENGLISH - INDONESIAN TRANSLATION OF OBAMA’S SPEECH IN INDONESIA UNIVERSITY <i>Diyah Fitri Wulandari</i> .....	137
SANTRI’S LANGUAGE ATTITUDE TOWARD JAVANESE LANGUAGE ON PESANTREN TEACHING WITHIN THE CONTEXT OF JAVANESE LANGUAGE MAINTENANCE <i>Dwi Wulandari and Wiwik Sundari</i> .....	141
THE TRANSLATION OF SHALL IN THE INDONESIAN VERSION OF ASEAN CHARTER: A PRELIMINARY RESEARCH ON PATTERNS AND CONSEQUENCES OF MODAL TRANSLATION <i>Dyka Santi Des Anditya</i> .....	146
PERGESERAN PENGGUNAAN KEIGO KHUSUSNYA PADA PENGGUNAAN HONORIFIC TITLE (呼称) DAN PERUBAHAN HUBUNGAN ATASAN DAN BAWAHAN YANG TERJADI PADA PERUSAHAAN JEPANG <i>Elisa Carolina Marion</i> .....	151
STUDENTS’ DERIVATION MASTERY AND THEIR ABILITY IN ANSWERING READING QUESTIONS <i>Emilia Ninik Aydawati</i> .....	156
CONTRASTIVE ANALYSIS OF PROVERBS IN INDONESIAN AND ENGLISH: AN ANTHROPOLOGICAL LINGUISTIC STUDY <i>Endang Setyowati</i> .....	159
VARIASI BAHASA DALAM SINETRON TUKANG BUBUR NAIK HAJI (TBNH) KAJIAN ETNOGRAFI KOMUNIKASI <i>Endang Sri Wahyuni and Khrishandini</i> .....	164

PERUBAHAN KATA GANTI ORANG KEDUA DALAM BAHASA JAWA <i>Endro Nugroho Wasono Aji</i> .....	168
Pengenalan Ungkapan-ungkapan Bahasa Jawa: Suatu Upaya Pemertahanan Bangsa <i>Enita Istriwati</i> .....	172
Bentuk dan Fungsi Kalimat Tanya dalam Talk Show “Indonesia Lawyers Club” <i>Erlita Rusnaningtias</i> .....	177
Kata Serapan dalam Bahasa Jepang: Upaya Bangsa Jepang dalam Pemeliharaan Bahasa dan Terjadinya Pergeseran Bahasa sesuai Budaya Lokal <i>Esther Hersline Palandi</i> .....	182
Pergeseran Bahasa Hokkian dalam Upacara Te Pai di Indonesia <i>Fandy Prasetya Kusuma</i> .....	187
Using Thematic Progression Patterns with Cooperative Learning Method (TP-CL) to Improve the Writing Skill of the English Department Students of UTM in the Academic Year 2011/2012 <i>Farikah</i> .....	192
Penggunaan Bahasa dalam Ranah Jual Beli di Pasar Terapung Lok Baintan Kabupaten Banjar Kalimantan Selatan <i>Fatchul Mu’in</i> .....	197
Pendekatan Emik-etik terhadap Upacara Pasak Indong Suku Tidung di Desa Salimbatu, Kecamatan Tanjung Palas Tengah, Kalimantan Utara Kajian Linguistik Antropologi <i>Fitriansyah</i> .....	201
Presupposition Analysis of the Question in Mata Najwa “Politik Selebriti” Episode <i>Habiba Al Umami</i> .....	205
Tuturan Pamali dalam Tradisi Lisan Masyarakat Banjar <i>Hatmiati</i> .....	210
Kesalahan dalam Penentuan Jenis Kalimat dalam Bahasa Indonesia: Studi Kasus Mahasiswa TPB IPB <i>Henny Krishnawati and Defina</i> .....	215



MUATAN SOSIO-KULTURAL DAN POLITIS DALAM BAHASA DARI SEGI ETNOGRAFI <i>Herudjati Purwoko</i> .....	220
PERGESERAN PEMAKAIAN PRONOMINA PERSONA DALAM BAHASA INDONESIA INFORMAL REMAJA: STUDI KASUS FILM TANGKAPLAH DAKU KAU KUJITAK (1987) DAN BANGUN LAGI DONG, LUPUS (2013) <i>Icuk Prayogi</i> .....	225
THE ETHNOGRAPHY OF COMMUNICATION APPROACH TOWARDS THE MOTIVATORS’ SPEECH IN ORIFLAME <i>Ida Hendriyani</i> .....	230
PRANOTOCORO AS ONE OF THE SYMBOL OF JAVANESE CULTURE THAT BECOMES DIMINISH FROM DAY TO DAY <i>Ikha Adhi Wijaya</i> .....	235
SEMANTIC SHIFT ON MALAY WORDS IN CLASSICAL MALAY TEXT HIKAYAT HANG TUAH COMPARE TO MODERN MALAY (INDONESIAN LANGUAGE) AND THE RELATION TO CULTURAL CONTEXT <i>Ikmi Nur Oktavianti</i> .....	240
THE CREATION OF LANGUAGE THROUGH MOTTO (THE STUDY OF LANGUAGE AND ENTREPRENEURSHIP IN A MOTTO OF ACADEMIC INSTITUTION) <i>Juanda and M. Rayhan Bustam</i> .....	245
PENATAAN ULANG KAMUS DIALEK BANYUMASAN; SEBUAH SUMBANGAN LEKSIKOGRAFIS BAGI UPAYA PEMERTAHANAN DIALEK (RE-ORGANISATION OF BANYUMAS DIALECT DICTIONARY; LEXICOGRAPHIC CONTRIBUTION TO DIALECT PRESERVATION) <i>Kahar Dwi Prihantono</i> .....	250
STYLE AND REGISTER USED AT PONDOK PESANTREN (A DIMENSION OF SOSIOLINGUISTICS) <i>Kharisma Puspita Sari</i> .....	255
MODEL PEMBELAJARAN KOOPERATIF TEKNIK STUDENT TEAMS ACHIEVEMENT DIVISIONS (STAD) UNTUK MENINGKATKAN KETERAMPILAN MENULIS NARASI MAHASISWA ASING DI UNIVERSITAS SEBELAS MARET <i>Kundharu Saddhono</i> .....	259
LINGUISTIC ADAPTATION OF BAJO IN SUMBAWA ISLAND: A PRELIMINARY STUDY FOR SOCIAL MOTIVATION OF LANGUAGE CHANGE <i>Lalu Erwan Husnan</i> .....	263

SOSIALISASI DAN KEBIJAKAN ATAS KEBERAGAMAN BAHASA PADA MASYARAKAT TENGGER JAWA TIMUR: SEBUAH FENOMENA KEARIFAN LOKAL <i>Layli Hamida</i> .....	267
TARLING MUSIC AS A MEANS OF MAINTAINING INDIGENOUS JAVANESE LANGUAGE AT NORTHERN COAST (PANTURA) IN THE PROVINCES OF WEST JAVA AND CENTRAL JAVA <i>Leksito Rini</i> .....	271
A REFLECTION OF LANGUAGE ATTITUDE TOWARD KID CARTOONS: A CASE STUDY OF FIRST GRADERS IN MARSUDIRINI ELEMENTARY SCHOOL <i>Maria Christiani sugiarso</i> .....	274
THE FEATURES OF JAVANESE WOMEN SPEECH: A SOCIOLINGUISTICS STUDY BASED ON LAKOFF'S THEORY <i>Maria Yosephin Widarti Lestari</i> .....	279
STRATEGI INTERAKSI EKSTRA-TEKSTUAL GURU UNTUK MENINGKATKAN PEMAHAMAN TEKSTUAL SISWA TUNA GRAHITA <i>Masitha Achmad Syukri</i> .....	283
GENERASI MUDA JAWA PERKOTAAN KAGOK DENGAN BAHASA JAWANYA SENDIRI <i>M. Suryadi</i> .....	288
THE ANALYSIS OF FACE WANTS AS SELF IMAGE USED BY AGNES MONICA IN KICK ANDY SHOW <i>Mastuti Ajeng Subianti</i> .....	292
PENGGUNAAN BAHASA JAWA PADA UPACARA TUMURUNING KEMBARMAYANG SEBAGAI CERMINAN KEARIFAN BUDAYA JAWA <i>Meka Nitrit Kawasari</i> .....	295
PEMERTAHANAN DAN REVITALISASI BAHASA JAWA DIALEK BANTEN <i>Meti Istimurti</i> .....	300
KESENIAN JARANAN SEBAGAI BENTUK PEMERTAHANAN BAHASA JAWA <i>Miza Rahmatika Aini</i> .....	305
KO AND RIKA IN JAVANESE OF TEGAL <i>Mualimin</i> .....	309
A SOCIAL CONTEXT OF SASAK PERSONAL PRONOUNS <i>Muhammad</i> .....	313

PEDAGOGONOLOGIS SEBUAH KAJIAN FONOLOGI DAN ILMU PENDIDIKAN <i>Muhammad Nanang Qosim</i> .....	318
TINDAK TUTUR PERSUASIF DAN PROVOKATIF DALAM WACANA SPANDUK KAMPANYE PILKADA JAWA TENGAH TAHUN 2013 <i>Muhammad Rohmadi</i> .....	322
THE USE OF PERSONAL NAMES IN NAMING PRODUCTS <i>Muhammad Zulkarnain Ashya Hifa</i> .....	327
VERBA “MIRIP TAKUT” DALAM BAHASA MELAYU ASAHAN <i>Mulyadi</i> .....	331
GEJALA INKORPORASI PADA BAHASA MEDIA CETAK <i>Mulyono</i> .....	336
A FEMINIST STYLISTIC READING OF TRIYANTO TRIWIKROMO’S “TUJUH BELAS AGUSTUS TANPA TAHUN” <i>Mytha Candria</i> .....	341
PENGUNAAN BAHASA INGGRIS DALAM IKLAN MAKANAN DAN MINUMAN: PELUANG ATAUKAH ANCAMAN? <i>Neli Purwani</i> .....	346
BANJARESE IDEOLOGIES PORTRAYED IN SI PALUI <i>Ninuk Krismanti</i> .....	351
WOMEN, LANGUAGE AND CULTURAL CHANGE <i>Nungki Heriyati</i> .....	356
PENGARUH DIALEK LOKAL TERHADAP BAHASA MANDARIN YANG DIGUNAKAN MASYARAKAT TIONGHUA DI PURWOKERTO <i>Nunung Supriadi</i> .....	361
(RE)-READING A KARTINI’S LETTER USING CRITICAL DISCOURSE ANALYSIS <i>Nurhayati</i> .....	365
NAFAS BAHASA JAWA DI JAGAT MAYA <i>P. Ari Subagyo</i> .....	370
METAFORA SEBAGAI NASIHAT DALAM HOROSKOP JAWA: STUDI LINGUISTIK ANTROPOLOGIS <i>Prayudha</i> .....	375

ANNOTATION MODEL FOR LOANWORDS IN INDONESIAN CORPUS: A LOCAL GRAMMAR FRAMEWORK <i>Prihantoro</i> .....	380
PELESTARIAN BAHASA BALI DALAM PENDIDIKAN FORMAL: PERSPEKTIF POLITIK DAN REGULASI <i>Putu Sutama</i> .....	385
TINJAUAN RELATIVITAS BAHASA DALAM LAGU KERONCONG <i>Ratih Kusumaningsari</i> .....	390
KAJIAN PENERJEMAHAN IDEOLOGI DENGAN PENDEKATAN APPRAISAL <i>Retno Hendrastuti</i> .....	395
THE STRATEGY OF THE TEXT AND THE STRUCTURAL RELATIONS TO EXERCISE SUNDANESE CRITICS’ IDEOLOGICAL HEGEMONY <i>Retno Purwani Sari and Tatan Tawami</i> .....	400
PENGASINGAN RAMBU PETUNJUK DI PUSAT-PUSAT PERBELANJAAN DI SURABAYA <i>Retno Wulandari Setyaningsih</i> .....	403
SIKAP BERBAHASA PARA SISWA SEKOLAH DASAR ISLAM TERPADU KABUPATEN BANDUNG DALAM KONTEK MULTIBAHASA <i>Riadi Darwis</i> .....	408
IMPLEMENTATION OF ENGLISH LEARNING MODEL BASED ON NEGATIVE ANXIETY REDUCTION THROUGH CONSTRUCTIVISM THEORY IN BANJARBARU SENIOR HIGH SCHOOLS <i>Ridha Fadillah</i> .....	412
BAHASA JAWA DALAM SLOGAN-SLOGAN CALON GUBERNUR DAN WAKIL GUBERNUR JAWA TENGAH TAHUN 2013 <i>Rini Esti Utami</i> .....	417
PEMERTAHANAN BAHASA DAERAH SEBAGAI UPAYA MENINGKATKAN KETAHANAN BUDAYA <i>Rukni Setyawati</i> .....	422
ICT (WEB. DESIGN) AND JAVANESE LANGUAGE LEARNING IN INDONESIA: REVITALIZATION INDIGENOUS LANGUAGES <i>Ruth Hastutiningsih</i> .....	426
ANALYSIS OF IDIOMATIC EMOTION EXPRESSIONS DETECTED FROM ONLINE MOVIE REVIEWS <i>Sai-Rom Kim, Hae-Yun Lee, and Jeusun Nam</i> .....	431

LANGUAGE MAINTENANCE OF BALINESE MOTHER TONGUE THROUGH THE TRADITIONAL STORY TELLING (MESATUA) IN BATU BULAN VILLAGE, GIANYAR <i>Sang Ayu Isnur Maharani and I Komang Sumaryana Putra</i> .....	436
THE USE OF COHESIVE DEVICES IN RELATION TO THE QUALITY OF THE STUDENTS’ ARGUMENTATIVE WRITING <i>Sari Kusumaningrum</i> .....	441
DEVELOPING ISLAMIC-CONTENT BASED READING COMPREHENSION MATERIALS FOR ISLAMIC HIGHER EDUCATION <i>Sirajul Munir</i> .....	446
TIPOLOGI SINTAKSIS: URUTAN KATA DAN FRASA BAHASA BANJAR DAN IMPLIKASINYA <i>Siti Jamzaroh</i> .....	450
LANGUAGE MAINTENANCE AND SHIFT: HOW JAVANESE PRESERVED AND SHIFTED IN INDUSTRIAL AREA CASE STUDY IN NIKOMAS COMPANY <i>Siti Suharsih</i> .....	456
METAFORA YANG DIGUNAKAN OLEH DALANG DALAM MELAKONKAN WAYANG KULIT <i>Sogimin</i> .....	461
REFLEKSI KEDUDUKAN PEREMPUAN MINANGDALAM PITARUAH AYAH <i>Sri Andika Putri</i> .....	465
PANTUN BUKA PALANG PINTU: KEARIFAN LOKAL DALAM PERNIKAHAN ADAT BETAWI <i>Sri Sulihingtyas D.</i> .....	470
PERUNDUNGAN BAHASA DAERAH MELALUI PENGGUNAAN LOGAT DIALEK DALAM TAYANGAN SINETRON DI TELEVISI <i>Sri Wahyuni</i> .....	474
INDONESIAN NOUN PHRASE=NOUN+NOUN: A SEMANTIC PERSPECTIVE <i>Suparto</i> .....	479
SOLIDARITAS (TU) DAN KESOPANAN (VOUS) DALAM BAHASA JAWA SEBAGAI WUJUD KEARIFAN LOKAL <i>Surono</i> .....	484
LANGUAGE AND SAFETY <i>Sutarsih</i> .....	489

CONFORMITY TOWARDS LOCAL WISDOM AMONG THE SAME INDIGENOUS LANGUAGE SPEAKERS <i>Swany Chiakrawati</i> .....	492
LOSS OF WORDS IN MANDAILINGNESE <i>Syahron Lubis</i> .....	496
A SURVEY ON MOTIVATIONAL ORIENTATION IN LEARNING EFL OF PUBLIC ADMINISTRATION POST GRADUATE STUDENTS OF JENDERAL SOEDIRMAN UNIVERSITY <i>Syaifur Rochman</i> .....	501
ANALISIS KESANTUNAN BERBAHASA PADA KASET PASAMBAHAN ADAT ALEK MARAPULAI BALERONG GRUP JAKARTA: SEBUAH KARAKTERISTIK KEARIFAN LOKAL ETNIS MINANGKABAU <i>Syamsurizal</i> .....	505
THE LOSS OF IDENTITY OF SOME SUNDANESE CHILDREN IN BOGOR CITY DUE TO LACK OF EXPOSURE TO SUNDANESE LANGUAGE <i>Tatie Soedewo</i> .....	510
A STUDY ON STUDENTS’ ABILITY IN CONDUCTING CONVERSATION WITH NATIVE SPEAKERS: CROSS CULTURAL ASPECT AND ADJUSTMENT <i>Titi Rokhayati</i> .....	515
COMPANY’S PARTICIPATION IN THE LOCAL LANGUAGE RETENTION <i>Tubiyono</i> .....	520
ANALISIS WACANA PERCAKAPAN SIARAN “ON AIR” RADIO DANGDUT INDONESIA: PENDEKATAN PRAGMATIK <i>Wiwik Wijayanti</i> .....	525
DISCOURSE CONNECTORS IN ARGUMENTATIVE WRITINGS PRODUCED BY INDONESIAN EFL UNIVERSITY STUDENTS <i>Wuwuh Andayani</i> .....	530
PEMILIHAN BAHASA KELUARGA MUDA DI DESA KLOPODUWUR CERMIN PEMERTAHANAN IDENTITAS DAN EKSISTENSI BAHASA <i>Yenny Budhi Listianingrum</i> .....	535
RHETORICAL STRATEGIES IN FLOUTING GRICE’S MAXIMS AS FOUND IN “PYGMALION”. <i>Yenny Hartanto</i> .....	540
MOTHER'S TONGUE INFLUENCE TOWARDS NAMING IN KEBONADEM VILLAGE <i>Yozar Firdaus Amrullah</i> .....	545

THE EVOLUTION OF A CHRISTIAN TEXT FROM SEVENTEENTH-CENTURY MALAY TO MODERN-DAY INDONESIAN: A HISTORICAL LINGUISTICS STUDY FROM THE PERSPECTIVE OF TRANSFORMATIONAL-GENERATIVE MODEL <i>Yudha Thianto</i> .....	550
RETRIEVING LOCAL WISDOM IN KOREAN WITH THE SUPPORT OF CORPUS PROCESSING SOFTWARE <i>Jee-Sun Nam</i> .....	555

**SCHEDULE OF THE INTERNATIONAL SEMINAR  
"LANGUAGE MAINTENANCE AND SHIFT III (LAMAS III)"**

**DAY 1 (July 2, 2013)**

TIME	ACTIVITIES		ROOM
	NAME	TITLE	
09.30 – 10.45 WIB	REGISTRATION		PAKOEBUWONO
10.45 – 11.00 WIB	OPENING		PAKOEBUWONO
11.00 – 11.30 WIB	KEYNOTE SPEECH		PAKOEBUWONO
	Prof. Dr. Mahsun, M.S.		
11.30 – 12.30 WIB	LUNCH AND PRAY		PAKOEBUWONO
12.30 – 14.00 WIB	PLENNARY SESSION 1		PAKOEBUWONO
	Prof. Jee Sun Nam, Ph.D.	RETRIEVING LOCAL WISDOM IN KOREAN WITH THE SUPPORT OF CORPUS PROCESSING SOFTWARE	
	Dr. Johnny Tjia	ISU KEBERTAHANAN DALAM USAHA PENCAGARAN BAHASA	
	Dr. Suharno, M.Ed.	INCORPORATING LOCAL WISDOM INTO ENGLISH LANGUAGE TEACHING (ELT)	
	Moderator : J. Herudjati Purwoko, Ph.D		
14.00 – 15.30 WIB	PARRALEL SESSION 1 A		PAKOEBUWONO
	Kahar Dwi Prihantono	PENATAAN ULANG KAMUS DIALEK BANYUMASAN; SEBUAH SUMBANGAN LEKSIKOGRAFIS BAGI UPAYA PEMERTAHANAN DIALEK (RE-ORGANISATION OF BANYUMAS DIALECT DICTIONARY; LEXICOGRAPHIC CONTRIBUTION TO DIALECT PRESERVATION)	
	Mualimin	KO AND RIKA IN JAVANESE OF TEGAL	
	Rukni Setyawati	PEMERTAHANAN BAHASA DAERAH SEBAGAI UPAYA MENINGKATKAN KETAHANAN BUDAYA	
	Retno Wulandari Setyaningsih	PENGASINGAN RAMBU PETUNJUK DI PUSAT-PUSAT PERBELANJAAN DI SURABAYA	
14.00 – 15.30 WIB	PARRALEL SESSION 1 B		PAKOEBUWONO
	Herudjati Purwoko	MUATAN SOSIO-KULTURAL DAN POLITIS DALAM BAHASA DARI SEGI ETNOGRAFI	
	Syahron Lubis	LOSS OF WORDS IN MANDAILINGNESE	
	M. Suryadi	GENERASI MUDA JAWA PERKOTAAN KAGOK DENGAN BAHASA JAWANYA SENDIRI	
	Fatchul Mu'in	PENGGUNAAN BAHASA DALAM RANAH JUAL BELI DI PASAR TERAPUNG LOK BAIN TAN KABUPATEN BANJAR KALIMANTAN SELATAN	



TIME	NAME	TITLE	ROOM
14.00 – 15.30 WIB	<b>PARRALEL SESSION 1 C</b>		CEMPAKA
	Neli Purwani	PENGGUNAAN BAHASA INGGRIS DALAM IKLAN MAKANAN DAN MINUMAN: PELUANG ATAUKAH ANCAMAN?	
	Ikmi nur Oktavianti	SEMANTIC SHIFT ON MALAY WORDS IN CLASSICAL MALAY TEXT HIKAYAT HANG TUAH COMPARE TO MODERN MALAY (INDONESIAN LANGUAGE) AND THE RELATION TO CULTURAL CONTEXT	
	Nunung Supriadi	PENGARUH DIALEK LOKAL TERHADAP BAHASA MANDARIN YANG DIGUNAKAN MASYARAKAT TIONGHUA DI PURWOKERTO	
	Agustina Lestary	DO BANJARESE WOMEN AND MEN SPEAK DIFFERENTLY?	
14.00 – 15.30 WIB	<b>PARRALEL SESSION 1 D</b>		MELATI
	Esther Hesline Palandi	KATA SERAPAN DALAM BAHASA JEPANG: UPAYA BANGSA JEPANG DALAM PEMELIHARAAN BAHASA DAN TERJADINYA PERGESERAN BAHASA SESUAI BUDAYA LOKAL	
	Maria Yosephin Widarti Lestari	THE FEATURES OF JAVANESE WOMEN SPEECH: A SOCIOLINGUISTICS STUDY BASED ON LAKOFF'S THEORY	
	Meti Istimurti	PEMERTAHANAN DAN REVITALISASI BAHASA JAWA DIALEK BANTEN	
	Retno Purwani Sari Dan Tatan Tawami	THE STRATEGY OF THE TEXT AND THE STRUCTURAL RELATIONS TO EXERCISE SUNDANESE CRITICS' IDEOLOGICAL HEGEMONY	
14.00 – 15.30 WIB	<b>PARRALEL SESSION 1 E</b>		BOUGENVILLE
	Layli Hamida	SOSIALISASI DAN KEBIJAKAN ATAS KEBERAGAMAN BAHASA PADA MASYARAKAT TENGGER JAWA TIMUR: SEBUAH FENOMENA KEARIFAN LOKAL	
	Dwi Wulandari dan Wiwik Sundari	SANTRI'S LANGUAGE ATTITUDE TOWARD JAVANESE LANGUAGE ON PESANTREN TEACHING WITHIN THE CONTEXT OF JAVANESE LANGUAGE MAINTENANCE	
	Kharisma Puspita Sari	STYLE AND REGISTER USED AT PONDOK PESANTREN (A DIMENSION OF SOCIOLINGUISTICS)	
	Anandha	FENOMENA SOSIOLINGUISTIK BAHASA JAWA PESISIR SEBAGAI CERMIN KEARIFAN LOKAL	
15.30 – 16.00 WIB	<b>BREAK AND PRAY</b>		PAKOEJUWONO

TIME	NAME	TITLE	ROOM
16.00 – 17.30 WIB	<b>PARRALEL SESSION 2 A</b>		PAKOEBUWONO
	Surono	SOLIDARITAS (TU) DAN KESOPANAN (VOUS) DALAM BAHASA JAWA SEBAGAI WUJUD KEARIFAN LOKAL	
	Riadi Darwis	SIKAP BERBAHASA PARA SISWA SEKOLAH DASAR ISLAM TERPADU KABUPATEN BANDUNG DALAM KONTEKS MULTIBAHASA	
	Fandy Prasetya Kusuma	PERGESERAN BAHASA HOKKIAN DALAM UPACARA TE PAI DI INDONESIA	
	Elisa Carolina Marion	PERGESERAN PENGGUNAAN KEIGO KHUSUSNYA PADA PENGGUNAAN HONORIFIC TITLE (呼称) DAN PERUBAHAN HUBUNGAN ATASAN DAN BAWAHAN YANG TERJADI PADA PERUSAHAAN JEPANG	
16.00 – 17.30 WIB	<b>PARRALEL SESSION 2 B</b>		PAKOEBUWONO
	Dian Swastika	JAVANESE EXPRESSIONS AS LOCAL WISDOM MANIFESTATION	
	Meka Nitrit Kawasari	PENGGUNAAN BAHASA JAWA PADA UPACARA TUMURUNING KEMBARMAYANG SEBAGAI CERMINAN KEARIFAN BUDAYA JAWA	
	Endang Setyowati	CONTRASTIVE ANALYSIS OF PROVERBS IN INDONESIAN AND ENGLISH: AN ANTHROPOLOGICAL LINGUISTIC STUDY	
Prayudha	METAFORA SEBAGAI NASIHAT DALAM HOROSKOP JAWA: STUDI LINGUISTIK ANTROPOLOGIS		
16.00 – 17.30 WIB	<b>PARRALEL SESSION 2 C</b>		CEMPAKA
	Sri Sulihingtyas D.	PANTUN BUKA PALANG PINTU: KEARIFAN LOKAL DALAM PERNIKAHAN ADAT BETAWI	
	Hatmiati	TUTURAN PAMALI DALAM TRADISI LISAN MASYARAKAT BANJAR	
	Atin Kurniawati	JAVANESE VIEW ON EDUCATION: AN ETNOLINGUISTIC STUDY	
Muhammad	A SOCIAL CONTEXT OF SASAK PERSONAL PRONOUNS		
16.00 – 17.30 WIB	<b>PARRALEL SESSION 2 D</b>		MELATI
	Habiba Al Umami	PRESUPPOSITION ANALYSIS OF THE QUESTION IN MATA NAJWA "POLITIK SELEBRITI" EPISODE	
	Muhammad Rohmadi	TINDAK TUTUR PERSUASIF DAN PROVOKATIF DALAM WACANA SPANDUK KAMPANYE PILKADA JAWA TENGAH TAHUN 2013	
	Endro nugroho wasono aji	PERUBAHAN KATA GANTI ORANG KEDUA DALAM BAHASA JAWA	
Yenny budhi listianingrum	PEMILIHAN BAHASA KELUARGA MUDA DI DESA KLOPODUWUR CERMIN PEMERTAHANAN IDENTITAS DAN EKSISTENSI BAHASA		

TIME	NAME	TITLE	ROOM
16.00 – 17.30 WIB	<b>PARRALEL SESSION 2 E</b>		BOUGENVILLE
	Sri wahyuni	PERUNDUNGAN BAHASA DAERAH MELALUI PENGGUNAAN LOGAT DIALEK DALAM TAYANGAN SINETRON DI TELEVISI	
	Lalu erwan husnan	LINGUISTIC ADAPTATION OF BAJO IN SUMBAWA ISLAND: A PRELIMINARY STUDY FOR SOCIAL MOTIVATION OF LANGUAGE CHANGE	
	Tubiyono	COMPANY'S PARTICIPATION IN THE LOCAL LANGUAGE RETENTION	
	Endang sri wahyuni dan khrishandini	VARIASI BAHASA DALAM SINETRON TUKANG BUBUR NAIK HAJI (TBNH) KAJIAN ETNOGRAFI KOMUNIKASI	
17.30 – 18.30 WIB	<b>BREAK AND PRAY</b>		PAKOEBUWONO
18.30 – 19.30 WIB	<b>PARALLEL SESSION 2 F-1</b>		PAKOEBUWONO A
	Rini Esti Utami	BAHASA JAWA DALAM SLOGAN-SLOGAN CALON GUBERNUR DAN WAKIL GUBERNUR JAWA TENGAH TAHUN 2013	
	Miza Rahmatika Aini	KESENIAN JARANAN SEBAGAI BENTUK PEMERTAHANAN BAHASA JAWA	
	Putu Utama	PELESTARIAN BAHASA BALI DALAM PENDIDIKAN FORMAL: PERSPEKTIF POLITIK DAN REGULASI	
	Leksito Rini	TARLING MUSIC AS A MEANS OF MAINTAINING INDIGENOUS JAVANESE LANGUAGE AT NORTHERN COAST (PANTURA) IN THE PROVINCES OF WEST JAVA AND CENTRAL JAVA	
	Enita Istriwati	PENGENALAN UNGKAPAN-UNGKAPAN BAHASA JAWA: SUATU UPAYA PEMERTAHANAN BANGSA	
	Icuk Prayogi	PERGESERAN PEMAKAIAN PRONOMINA PERSONA DALAM BAHASA INDONESIA INFORMAL REMAJA: STUDI KASUS FILM TANGKAPLAH DAKU KAU KUJITAK (1987) DAN BANGUN LAGI DONG, LUPUS (2013)	

TIME	NAME	TITLE	ROOM
18.30 – 19.30 WIB	<b>PARALLEL SESSION 2 F-2</b>		PAKOEBUWONO B
	Ikha Adhi Wijaya	PRANOTOCORO AS ONE OF THE SYMBOL OF JAVANESE CULTURE THAT BECOMES DIMINISH FROM DAY TO DAY	
	Siti Suharsih	LANGUAGE MAINTENANCE AND SHIFT: HOW JAVANESE PRESERVED AND SHIFTED IN INDUSTRIAL AREA CASE STUDY IN NIKOMAS COMPANY	
	Sang Ayu Isnu Maharani dan I Komang Sumaryana Putra	LANGUAGE MAINTENANCE OF BALINESE MOTHER TONGUE THROUGH THE TRADITIONAL STORY TELLING (MESATUA) IN BATU BULAN VILLAGE, GIANYAR	
	Sutarsih	LANGUAGE AND SAFETY	
	Anang Febri Priambada	ALIH KODE DAN CAMPUR KODE PADA CERAMAH BUDAYA EMHA AINUN NAJIB	
	Didik Santoso	PEKALONGAN DIALECT IN RAPROX BAND LYRICS	
	Maria Christiani sugiarto	A REFLECTION OF LANGUAGE ATTITUDE TOWARD KID CARTOONS: A CASE STUDY OF FIRST GRADERS IN MARSUDIRINI ELEMENTARY SCHOOL	
18.30 – 19.30 WIB	<b>PARALLEL SESSION 2 F-3</b>		PAKOEBUWONO C
	Asih Prihandini dan N. Denny Nugraha	KEARIFAN LOKAL MITIGASI BENCANA DALAM TRADISI SASTRA LISAN NUSANTARA	
	Yozar Firdaus Amrullah	MOTHER'S TONGUE INFLUENCE TOWARDS NAMING IN KEBONADEM VILLAGE	
	Muhammad Zulkarnain Ashya hifa	THE USE OF PERSONAL NAMES IN NAMING PRODUCTS	
	Ida Hendriyani	THE ETHNOGRAPHY OF COMMUNICATION APPROACH TOWARDS THE MOTIVATORS' SPEECH IN ORIFLAME	
	Bambang Hariyanto	THE IDENTITY OF JAVANESE PEOPLE (A STUDY ON SELAMATAN IN EAST JAVA, ETHNOLINGUISTICS PERSPECTIVE)	
	Abadi Supriatin	BAHASA PERMOHONAN DI DALAM TRADISI KLIWONAN DI "SUMUR BERKAH" DESA WONOYOSO KABUPATEN PEKALONGAN	
	Mastuti Ajeng Subianti	THE ANALYSIS OF FACE WANTS AS SELF IMAGE USED BY AGNES MONICA IN KICK ANDY SHOW	

TIME	NAME	TITLE	ROOM
18.30 – 19.30 WIB	<b>PARALLEL SESSION 2 F-4</b>		PAKOEBUWONO D
	Wuwuh Andayani	DISCOURSE CONNECTORS IN ARGUMENTATIVE WRITINGS PRODUCED BY INDONESIAN EFL UNIVERSITY STUDENTS	
	Muhammad Nanang Qosim	PEDAGOGONOLOGIS SEBUAH KAJIAN FONOLOGI DAN ILMU PENDIDIKAN	
	Juanda dan M. Rayhan Bustam	THE CREATION OF LANGUAGE THROUGH MOTTO (THE STUDY OF LANGUAGE AND ENTREPRENEURSHIP IN A MOTTO OF ACADEMIC INSTITUTION)	
	Fitriansyah	PENDEKATAN EMIK-ETIK TERHADAP UPACARA PASAK INDONG SUKU TIDUNG DI DESA SALIMBATU, KECAMATAN TANJUNG PALAS TENGAH, KALIMANTAN UTARA KAJIAN LINGUISTIK ANTROPOLOGI	
	Sogimin	METAFORA YANG DIGUNAKAN OLEH DALANG DALAM MELAKONKAN WAYANG KULIT	
18.30 – 19.30 WIB	<b>PARALLEL SESSION 2 F-5</b>		PAKOEBUWONO E
	Henny Krishnawati dan Defina	KESALAHAN DALAM PENENTUAN JENIS KALIMAT DALAM BAHASA INDONESIA: STUDI KASUS MAHASISWA TPB IPB	
	Emilia Ninik Aydawati	STUDENTS' DERIVATION MASTERY AND THEIR ABILITY IN ANSWERING READING QUESTIONS	
	Masitha Achmad Syukri	STRATEGI INTERAKSI EKSTRA-TEKSTUAL GURU UNTUK MENINGKATKAN PEMAHAMAN TEKSTUAL SISWA TUNA GRAHITA	
	Titi Rokhayati	A STUDY ON STUDENTS' ABILITY IN CONDUCTING CONVERSATION WITH NATIVE SPEAKERS: CROSS CULTURAL ASPECT AND ADJUSTMENT	
	Sari Kusumaningrum	THE USE OF COHESIVE DEVICES IN RELATION TO THE QUALITY OF THE STUDENTS' ARGUMENTATIVE WRITING	
19.30 – 21.00 WIB	<b>PARRALEL SESSION 3 A</b>		PAKOEBUWONO
	P. Ari Subagyo	NAFAS BAHASA JAWA DI JAGAT MAYA	
	Sri Andika Putri	REFLEKSI KEDUDUKAN PEREMPUAN MINANG DALAM PITARUAH AYAH	
	Erlita Rusnaningtias	BENTUK DAN FUNGSI KALIMAT TANYA DALAM TALK SHOW "INDONESIA LAWYERS CLUB"	
	Ninuk Krismanti	BANJARESE IDEOLOGIES PORTRAYED IN SI PALUI	

TIME	NAME	TITLE	ROOM
19.30 – 21.00 WIB	<b>PARRALEL SESSION 3 B</b>		PAKOEBUWONO
	Nungki Heriyati	WOMEN, LANGUAGE AND CULTURAL CHANGE	
	Nurhayati	(RE)-READING A KARTINI'S LETTER USING CRITICAL DISCOURSE ANALYSIS	
	Wiwik Wijayanti	ANALISIS WACANA PERCAKAPAN SIARAN "ON AIR" RADIO DANGDUT INDONESIA: PENDEKATAN PRAGMATIK	
	Yenny Hartanto	RHETORICAL STRATEGIES IN FLOUTING GRICE'S MAXIMS AS FOUND IN "PYGMALION".	
19.30 – 21.00 WIB	<b>PARRALEL SESSION 3 C</b>		CEMPAKA
	Deli Nirmala	LOCAL WISDOM IN JAVANESE PROVERBS (A COGNITIVE LINGUISTIC APPROACH)	
	Ratih Kusumaningsari	TINJAUAN RELATIVITAS BAHASA DALAM LAGU KERONCONG	
	Aan Setyawan	THE WEALTH CONCEPT OF JAVANESE SOCIETY: ANTHROPOLOGICAL LINGUISTICS APPROACH IN CUBLAK-CUBLAK SUWENG FOLKSONG	
	Tatie Soedewo	THE LOSS OF IDENTITY OF SOME SUNDANESE CHILDREN IN BOGOR CITY DUE TO LACK OF EXPOSURE TO SUNDANESE LANGUAGE	
19.30 – 21.00 WIB	<b>PARRALEL SESSION 3 D</b>		MELATI
	Ridha Fadillah	IMPLEMENTATION OF ENGLISH LEARNING MODEL BASED ON NEGATIVE ANXIETY REDUCTION THROUGH CONSTRUCTIVISM THEORY IN BANJARBARU SENIOR HIGH SCHOOLS	
	Kundharu Saddhono	MODEL PEMBELAJARAN KOOPERATIF TEKNIK STUDENT TEAMS ACHIEVEMENT DIVISIONS (STAD) UNTUK MENINGKATKAN KETERAMPILAN MENULIS NARASI MAHASISWA ASING DI UNIVERSITAS SEBELAS MARET	
	Farikah	USING THEMATIC PROGRESSION PATTERNS WITH COOPERATIVE LEARNING METHOD (TP-CL) TO IMPROVE THE WRITING SKILL OF THE ENGLISH DEPARTMENT STUDENTS OF UTM IN THE ACADEMIC YEAR 2011/2012	
	Amrih Bkti Utami	THE IMPORTANCE OF NOTICING IN IMPROVING EFL STUDENTS' WRITING SKILLS	

TIME	NAME	TITLE	ROOM
19.30 – 21.00 WIB	<b>PARRALEL SESSION 3 E</b>		BOUGENVILLE
	Yudha Thianto	THE EVOLUTION OF A CHRISTIAN TEXT FROM SEVENTEENTH-CENTURY MALAY TO MODERN-DAY INDONESIAN: A HISTORICAL LINGUISTICS STUDY FROM THE PERSPECTIVE OF TRANSFORMATIONAL-GENERATIVE MODEL	
	Suparto	INDONESIAN NOUN PHRASE=NOUN+NOUN: A SEMANTIC PERSPECTIVE	
	Won-Fill Jung, Eunchae Son, Jaemog Song Dan Jeesun Nam	SYNTACTICO-SEMANTIC CLASSIFICATION OF SENTIMENT WORDS IN THE ELECTRONIC DICTIONARY DECO	
	Sai-Rom Kim, Jeesun Nam Dan Hae-Yun Lee	ANALYSIS OF IDIOMATIC EMOTION EXPRESSIONS DETECTED FROM ONLINE MOVIE REVIEWS	

**DAY 2 (July 3, 2013)**

TIME	ACTIVITIES		ROOM
	NAME	TITLE	
08.00 – 09.30 WIB	<b>PARRALEL SESSION 4 A</b>		ANGGREK 1
	Diyah Fitri Wulandari	THEMATIC STRUCTURE SHIFT FOUND IN ENGLISH - INDONESIAN TRANSLATION OF OBAMA'S SPEECH IN INDONESIA UNIVERSITY	
	Retno Hendrastuti	KAJIAN PENERJEMAHAN IDEOLOGI DENGAN PENDEKATAN APPRAISAL	
	Dyka Santi Des Anditya	THE TRANSLATION OF SHALL IN THE INDONESIAN VERSION OF ASEAN CHARTER: A PRELIMINARY RESEARCH ON PATTERNS AND CONSEQUENCES OF MODAL TRANSLATION	
	Baharuddin	TRANSLATION UNIT IN THE TRANSLATION OF AL-QURAN INTO INDONESIA	
08.00 – 09.30 WIB	<b>PARRALEL SESSION 4 B</b>		ANGGREK 2
	Mulyadi	VERBA "MIRIP TAKUT" DALAM BAHASA MELAYU ASAHAN	
	Agus Subiyanto	MOTION-DIRECTION SERIAL VERB CONSTRUCTIONS IN JAVANESE: A LEXICAL FUNCTIONAL APPROACH	
	Siti Jamzaroh	TIPOLOGI SINTAKSIS: URUTAN KATA DAN FRASA BAHASA BANJAR DAN IMPLIKASINYA	
	Mulyono	GEJALA INKORPORASI PADA BAHASA MEDIA CETAK	

TIME	NAME	TITLE	ROOM	
08.00 – 09.30 WIB	<b>PARRALEL SESSION 4 C</b>			ANGGREK 3
	Mytha Candria	A FEMINIST STYLISTIC READING OF TRIYANTO TRIWIKROMO'S "TUJUH BELAS AGUSTUS TANPA TAHUN"		
	Ariya Jati	A LYRIC'S WORTH IN GESANG'S "CAPING GUNUNG"		
	Agus Edy Laksono	TINDAK ILOKUSI PROPAGANDA CAGUB-CAWAGUB JAWA TENGAH PERIODE 2013-2018		
	Ade Husnul Mawadah	PENGGUNAAN BAHASA DAERAH DALAM IKLAN LAYANAN MASYARAKAT SEBAGAI ALAT PEMERTAHANAN BUDAYA BANGSA (STUDI KASUS DI KOTA SERANG PROVINSI BANTEN)		
TIME	NAME	TITLE	ROOM	
08.00 – 09.30 WIB	<b>PARRALEL SESSION 4 D</b>			MELATI
	Christina	THE INFLUENCE OF TRADITIONAL MAIDS' JAVANESE TO CHILDREN'S LANGUAGE (A CASE STUDY AT KAMPUNG KENTENG, KEJIWAN, WONOSOBO)		
	Bernadetta Yuniati Akbariah	METAPHORICAL SWITCHING: A LINGUISTIC REPERTOIRE OF MUSLIM JAVANESE PRIESTS		
	Swany Chiakrawati	CONFORMITY TOWARDS LOCAL WISDOM AMONG THE SAME INDIGENOUS LANGUAGE SPEAKERS		
	Syaifur Rochman	A SURVEY ON MOTIVATIONAL ORIENTATION IN LEARNING EFL OF PUBLIC ADMINISTRATION POST GRADUATE STUDENTS OF JENDERAL SORDIRMAN UNIVERSITY		
	Syamsurizal	ANALISIS KESANTUNAN BERBAHASA PADA KASET PASAMBAHAN ADAT ALEK MARAPULAI BALERONG GRUP JAKARTA: SEBUAH KARAKTERISTIK KEARIFAN LOKAL ETNIS MINANGKABAU		
08.00 – 09.30 WIB	<b>PARRALEL SESSION 4 E</b>			BOUGENVILLE
	Agnes Widyaningrum	MULTICULTURAL ENGLISH CURRICULUM ACCOMODATATING LOCAL WISDOM		
	Ruth Hastutiningsih	ICT (WEB. DESIGN) AND JAVANESE LANGUAGE LEARNING IN INDONESIA: REVITALIZATION INDIGENOUS LANGUAGES		
	Prihantoro	ANNOTATION MODEL FOR LOANWORDS IN INDONESIAN CORPUS: A LOCAL GRAMMAR FRAMEWORK		
	Sirajul Munir	DEVELOPING ISLAMIC-CONTENT BASED READING COMPREHENSION MATERIALS FOR ISLAMIC HIGHER EDUCATION		
09.30 – 10.00 WIB	<b>BREAK</b>			ANGGREK



<b>TIME</b>	<b>NAME</b>	<b>TITLE</b>	<b>ROOM</b>
10.00 – 11.30 WIB	<b>PLENNARY 2</b>		ANGGREK
	Prof. Dr. Bambang Kaswanti Purwo	ON UNDERSTANDING LOCAL WISDOM THROUGH RIDDLES IN JAVANESE, SUNDANESE, AND WOISIKA LANGUAGE	
	Prof. Dr. I Dewa Putu Wijana, S.U., M.A.	KEBANGGAN BERBAHASA SEBAGAIMANA YANG TEREFLAKSI DALAM WACANA TEKA-TEKI	
	Prof. Drs. Ketut Artawa, MA., Ph.D.	KEARIFAN LOKAL: PERTARUNGAN ANTARA TEKS IDEAL DAN TEKS SOSIAL	
	<b>Moderator</b> : Dr. Agus Subyanto, M.A.		
11.30 – 12.00 WIB	<b>CLOSING</b>		ANGGREK

## MOTION-DIRECTION SERIAL VERB CONSTRUCTIONS IN JAVANESE: A LEXICAL-FUNCTIONAL APPROACH

Agus Subiyanto

Faculty of Humanities Diponegoro University, Semarang

Email: [subaling@gmail.com](mailto:subaling@gmail.com)

### Abstract

*Motion-direction serialization (MDS) is a type of verb serialization that involves motion and directional verbs. This type of verb serialization commonly occurs in serializing languages including Javanese. This paper aims to discuss the characteristics and syntactic structure of MDS in Javanese. The syntactic structure, which comprises constituent and functional structures, is presented by using the theory of lexical-functional grammar (LFG). By adopting the lexical conceptual structure, the writer presents a model of functional structure to explain the syntactic and semantic relation between the motion verb and the directional verb in MDS. The data used in this study were taken from the novel "Suparto Brata's Omnibus: Kumpulan Roman" written by Suparto Brata (2007). In addition, this paper also used spoken data from two Javanese native speakers of the Surakarta dialect. The result shows that MDS in Javanese shares the same SUBJ argument, aspect, and negation. This shows that MDS expresses a single event. The LFG analysis of MDS shows that the directional verb has an X-COMP function, which is semantically represented as DIRECTION in the functional structure. The use of lexical conceptual structure in lexical entry and functional structure can clearly show the semantic and syntactic relation of the verbs involved in MDS.*

**Key words:** motion-direction serialization, Javanese, lexical-functional grammar

### 1. Introduction

The term 'serialization' in this paper refers to Durie (1988:3) stating that serialization is composed of two or more verbs juxtaposed in such a way that they behave as a single predicate. These verbs share one or more core arguments, and neither verb is subordinate to the other. In addition, the verbs are not connected with any marker of subordination or coordination, and they do not have a separate scope for tense, mood, aspect, illocutionary force and negation.

Based on the semantic relation of their verbs, serial verb constructions (SVCs) can be distinguished into several types one of which is motion-direction. This verb serialization is composed of a deictic verb and a directional verb, or a manner of motion verb and a directional verb. Motion-direction serialization is commonly found in serializing languages (see Durie, 1997). In other words, if a language has SVCs, it will have the motion type. This is due to the fact that basic motion verbs such as 'go' and 'come', are the most serializable verbs (see Aikhenvald, 2006:48).

This paper aims to discuss motion-direction verb serializations in Javanese. The questions addressed in the paper are as follows. Firstly, what are the characteristics of motion-direction verb serialization in Javanese. Secondly, how to describe the syntactic and semantic structure of motion-direction SVCs within the framework of lexical functional grammar. By adopting Andrews and Manning's (1999) and Sudmuk's (2005) model of lexical conceptual structure (LCS) within the lexical entry and functional structure, this paper will present a model of parallel structures for motion-direction SVCs in Javanese.

### 2. Theoretical Review

Lexical Functional Grammar or LFG for short is a theory of non-transformational generative linguistics initially developed by Bresnan and Kaplan in 1970's. This theory has been extensively developed by lexical-functional linguists such as Bresnan (2001), Dalrymple (2001), Choi (1997), dan, Kroeger (1993, 2004), and Falk (2001), to discuss various complex syntactic, semantic, and even pragmatic structures (see, among others, Butt (1995, 1997), Choi (1997)

LFG assumes that language is best described by using parallel structures that represent different facets or levels of linguistic organization and information (Dalrymple, 2001). Among the levels of

representation in LFG are constituent structure (c-structure) and functional structure (-structure). These levels of representation correspond to each other to describe the syntactic structure of a language. C-structure is a surface phrase structure, conveying category information, and information on precedence and dominance of constituents. In LFG, c-structure is described by adopting the principles of X-bar theory in that every syntactic structure is endocentric or has a head. F-structure represents grammatical relations such as SUBJ and OBJ and semantic roles of arguments required by a verb predicate. In this study, f-structure is described by using a lexical conceptual structure (LCS) in that the semantic relation of the verbs involved in motion-direction serialization can be described.

### 3. Research Method

The data for this paper were taken from a Javanese novel entitled *Suparto Brata's Omnibus: Kumpulan Roman* written by Suparto Brata (2007). To collect the data, the writer used an observation method with a note-taking technique. In addition, this paper also used spoken data from two Javanese native speakers of the Surakarta dialect. The spoken data were collected by using an interview method with an elicitation technique. To analyze the data, the writer used referential, distributional, and reflective-introspective methods (Sudaryanto, 1993).

### 4. Characteristics of Motion-Direction SVCs in Javanese

Motion-direction SVCs in Javanese are composed of a deictic verb and a directional verb, or a manner of motion verb and a directional verb. In other words, these constructions have directional verbs occurring as the second verb, and deictic or manner of motion verbs as the first verb. In this case, motion verbs are the ones expressing 'situation containing movement or maintenance of a stationary location' (Givon, 1984:61). Motion verbs can be deictic verbs, such as *lunga* 'go' and *teka* 'come', or manner of motion verbs, such as *mlayu* 'run', *mlaku* 'walk', *mbrangkang* 'crawl' and *mlangkah* 'step'. Meanwhile, directional verbs or path verbs can be distinguished into source path verbs, such as the verb *mrene* 'move overhere', goal path verbs, such as the verbs *metu* 'go out' and *mrana* 'move there', and route path verbs as the verbs *nyabrang* 'cross', *ngubengi* 'surround', *nengen* 'move to the right', and *ngalor* 'move to the north' (see Pancheva, 2009:9-10)

Constructions in (1) to (4) below are some examples of motion SVCs in Javanese. In (1), the verb *lunga* 'go' is deictic verb, and the verb *mrana* 'move there' expresses the directional meaning. Meanwhile, the verbs *mlaku* 'walk' in (2), *mlangkah* 'step' in (3), and *mlayu* 'run' in (4) are manner of motion verbs. These verbs are followed respectively with direction verbs, which are *nyabrang* 'cross', *maju* 'move forward', and *ngubengi* 'surround'

- (1) *Dheweke arep lunga mrana sore iki*  
3SG FUT go move there afternoon this  
'He will go there this afternoon'
- (2) *Astirin mlaku nyabrang dalam ...* (Brata, 2007: 54)  
NAME walk cross street  
'Astirin was walking across the street'
- (3) *Sing kathok irengora isa mlangkah maju*  
REL shorts black NEG can step move forward  
'The one wearing black shorts can not step forward'
- (4) *Hartono mlayu ngubengi lapangan*  
NAME run surround field  
'Hartono is running round the field'

The verbs composing motion-direction SVCs above share the same SUBJ argument, aspect, mood and polarity. In the constructions above, the verbs cannot be separated with an aspect, mood, or negation marker. In this case, the aspect, mood, or negation marker comes before the first verb to modify not only the first verb but also the second one. This shows that the two verbs express a single macro event, which is composed of two subevents. This is different from a structure of coordination, which shows separate events, as in (5).

- (5) *Saben esuk Hartono mlayu lan ngubengi lapangan*  
 Everyday morning NAME run and surround field  
 'Hartono runs and (he) surrounds the field every morning'

The verbs in the construction above, which are *mlayu* 'run' and *ngubengi* 'surround', express two separate events, which are the event of running and the event of surrounding. This shows that an SVC is different from a coordination structure. Unlike a coordination structure, SVCs form a single event as the verbs have a semantic integration.

### 5. Constituent and Functional Structure of Motion-Direction SVCs in Javanese

Before analyzing motion-direction SVCs, we should know the grammatical function of the second verb forming a motion-direction SVC. As mentioned in the previous section, the verbs in motion-direction SVCs share the same SUBJ. In these constructions the SUBJ of the second verb is controlled by the SUBJ of the first verb. This controlled SUBJ of the second verb implies that the verb has an open function, which can be X-complement (X-COMP) or X-adjunct (X-ADJ). X-COMP is an open argument function, and X-ADJ is an open non-argument function. Argument function is the one required by a verb predicate, whereas non-argument function is the one not required by the verb predicate. In motion-direction SVCs, the second verb should be treated as X-COMP as it is required by the first verb to complete a directed motion expression. As an X-COMP, the second verb should come directly after the first verb, and therefore, moving the second verb to the positions before SUBJ, as in (6), results in an ungrammatical sentence.

- (6) \**ngubengi lapangan dheweke mlayu*  
 surround field 3SG run  
 'He runs round the field'

The example above shows that the directional verb cannot be separated from the first verb. This shows that the directional verb has the X-COMP function, with the first verb as the head. This confirms the characteristic of complement stating that it comes closer to the head (see Newson et.al, 2006). Based on this argument, sentence (4) will have a constituent structure as in (7) below.

(7) C-structure of Sentence (4)

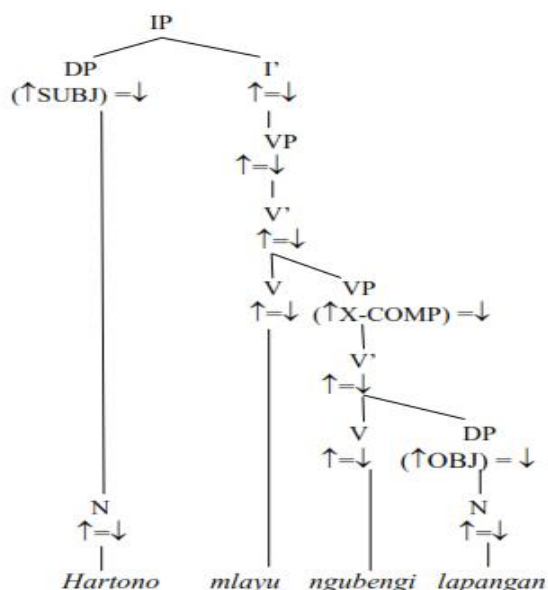

The c-structure above shows that the directional verb *ngubengi* and its OBJ *lapangan* function as X-COMP, and so they have the VP category parallel with the V category *mlayu* 'run', which is the

head. Note that the c-structure in LFG is completed with up and down arrows ( $\uparrow\downarrow$ ) showing the information flow. The up arrow shows the mother node, whereas the down arrow represents the self node.

In addition to the c-structure as given above, an LFG analysis should give the f-structure, which gives information about grammatical functions and their relation with the semantic roles. The f-structure is based on the information from the lexical entry. The following is the lexical entry for sentence (4).

(8) Lexical Entry

- (a) *Hartono* :N ( $\uparrow$ LCS REL) = 'HARTONO'
- (b) *lapangan* : N ( $\uparrow$ LCS REL) = 'FIELD'
- (c) *mlayu* : V ( $\uparrow$ LCS REL) = 'RUN'
- ( $\uparrow$ LCS AGENT) = ( $\uparrow$ SUBJ LCS)
- ( $\uparrow$ LCS DIRECTION) = ( $\uparrow$ X-COMP LCS)
- ( $\uparrow$ SUBJ) = ( $\uparrow$ X-COMP SUBJ)
- (d) *ngubengi* V ( $\uparrow$ LCS REL) = 'SURROUND'
- ( $\uparrow$ LCS AGENT) = ( $\uparrow$ SUBJ LCS)
- ( $\uparrow$ LCS THEME) = ( $\uparrow$ OBJ LCS)

The lexical entry above contains information about the lexical category, the meaning, the arguments required, as well as the cross referencing between grammatical functions and semantic roles. In the lexical entry, every lexicon has a relation (REL) function, which is PRED-attribute in the standar model (see Dalrymple, 2001; Subiyanto, 2013). This model of lexical entry, adopted from Sudmuk (2005) and Andrews and Manning (1999), replaces the PRED-attribute with LCS and a list of argument structures. The advantage of using this model is that it can capture the semantic relation between the motion verb and the directional verb in motion-direction serial verb constructions. Based on the lexical entry above, then the f-structure can be presented, as seen in (9) below.

(9) F-structure

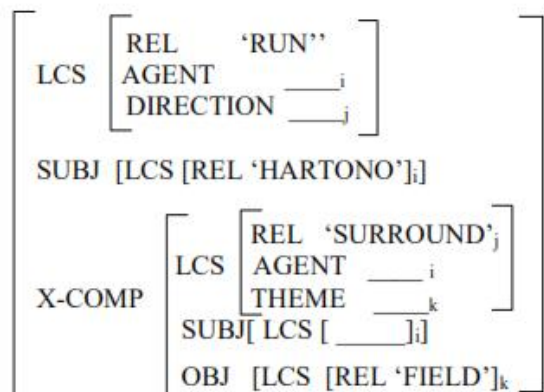

The f-structure above contains information of syntactic and semantic structures and the relation between these two structures. The syntactic structure relates to the grammatical functions like SUBJ, OBJ, and X-COMP, whereas the semantic structure relates to the semantic roles like AGENT and THEME, and the semantic information of the second verb attached to the first verb. Semantically, the verb meaning RUN needs AGENT and DIRECTION. The AGENT has the SUBJ function, whereas the verb that expresses DIRECTION has the X-COMP function.

The model of f-structure in (9) is the same as the one for motion-direction SVCs involving a deictic verb as in (1). In this sentence the deictic verb functions as the head, whereas the directional verb has an X-COMP function, which is semantically the DIRECTION.

**6. Conclusion**

Motion-direction SVCs in Javanese express a single event. This event is composed of two subevents, which are a motion event and a directional event. Syntactically, motion-direction SVCs form a



**Master Program in Linguistics, Diponegoro University  
in Collaboration with  
Balai Bahasa Provinsi Jawa Tengah**

**Jalan Imam Bardjo, S.H. No.5 Semarang  
Telp/Fax +62-24-8448717  
Email: [seminarlinguistics@gmail.com](mailto:seminarlinguistics@gmail.com)  
Website: [www.mli.undip.ac.id](http://www.mli.undip.ac.id)**

