

University of Windsor

Scholarship at UWindsor

Electronic Theses and Dissertations

Theses, Dissertations, and Major Papers

2017

A PHYSICAL DEMANDS COMPARISON OF THREE DIRECT-CURRENT RIGHT ANGLE POWER TOOL TIGHTENING STRATEGIES

Christian Lee Steingraber
University of Windsor

Follow this and additional works at: <https://scholar.uwindsor.ca/etd>

Recommended Citation

Steingraber, Christian Lee, "A PHYSICAL DEMANDS COMPARISON OF THREE DIRECT-CURRENT RIGHT ANGLE POWER TOOL TIGHTENING STRATEGIES" (2017). *Electronic Theses and Dissertations*. 6018.
<https://scholar.uwindsor.ca/etd/6018>

This online database contains the full-text of PhD dissertations and Masters' theses of University of Windsor students from 1954 forward. These documents are made available for personal study and research purposes only, in accordance with the Canadian Copyright Act and the Creative Commons license—CC BY-NC-ND (Attribution, Non-Commercial, No Derivative Works). Under this license, works must always be attributed to the copyright holder (original author), cannot be used for any commercial purposes, and may not be altered. Any other use would require the permission of the copyright holder. Students may inquire about withdrawing their dissertation and/or thesis from this database. For additional inquiries, please contact the repository administrator via email (scholarship@uwindsor.ca) or by telephone at 519-253-3000ext. 3208.

A PHYSICAL DEMANDS COMPARISON OF
THREE DIRECT-CURRENT RIGHT ANGLE POWER TOOL TIGHTENING
STRATEGIES

By

Christian Steingraber

A Thesis
Submitted to the Faculty of Graduate Studies
through the Faculty of Human Kinetics
in Partial Fulfillment of the Requirements for
the Degree of Masters of Human Kinetics
at the University of Windsor

Windsor, Ontario, Canada

2017

© 2017 Christian Steingraber

A PHYSICAL DEMANDS COMPARISON OF
THREE DIRECT-CURRENT RIGHT ANGLE POWER TOOL TIGHTENING
STRATEGIES

By

Christian Steingraber

APPROVED BY:

Z. Pasek
Department of Mechanical, Automotive and Materials Engineering

D. Andrews
Department of Kinesiology

J. Cort, Advisor
Department of Kinesiology

April 21st, 2017

DECLARATION OF ORIGINALITY

I hereby certify that I am the sole author of this thesis and that no part of this thesis has been published or submitted for publication.

I certify that, to the best of my knowledge, my thesis does not infringe upon anyone's copyright nor violate any proprietary rights and that any ideas, techniques, quotations, or any other material from the work of other people included in my thesis, published or otherwise, are fully acknowledged in accordance with the standard referencing practices. Furthermore, to the extent that I have included copyrighted material that surpasses the bounds of fair dealing within the meaning of the Canada Copyright Act, I certify that I have obtained a written permission from the copyright owner(s) to include such material(s) in my thesis and have included copies of such copyright clearances to my appendix.

I declare that this is a true copy of my thesis, including any final revisions, as approved by my thesis committee and the Graduate Studies office, and that this thesis has not been submitted for a higher degree to any other University or Institution.

ABSTRACT

The purpose of this study was to compare the physical demands associated with three direct-current (DC) right angle power tool tightening strategies. Thirty-six participants ($\bar{x} = 37.14$ years \pm 12.03) were assigned to one of two experimental groups: 1) Hard joint (30° , n=18), and, 2) Soft joint (540° , n=18). Within each experimental group, participants performed 36 trials, consisting of 3 tightening strategies, 3 target torques and 4 joint locations, in random order. Data from 3Dlinear sensor handle, motion capture markers, and Borg ratings were analyzed. Repeated measures ANOVA with Tukey's post hoc test were used to determine statistical significance ($p < 0.05$). Participants operating the TurboTight® fastening strategy experienced the least forces at the hand-handle interface, least joint angle displacements (shoulder & elbow angular displacement) as well as reported the lowest ratings of discomfort and strength.

ACKNOWLEDGEMENT

I would like to thank my family and friends for being so supportive throughout this long journey from High School, to an undergraduate degree to the final completion of my Master's. I appreciate the guidance, knowledge and support you have provided throughout the years which have shaped me into the person I am today. To my parents Ken and Rene, I cannot put into words how lucky I am to have you as my parents. You have given me the ability to shine in all aspects of life and I can only hope to provide a life for my child which is as good as the one you have given me. To my brother Jeremiah, I have always looked up to you as my older sibling. I appreciate your interest in all that I do and all the feedback you have provided me through this long journey.

I would like to thank my committee for agreeing to provide support and direction for my thesis work, Dr. Pasek and Dr. Andrews. Each of you have provided me with a great insight into the world of research and how to continually improve my knowledge base. I also want to thank my advisor, Dr. Joel Cort for his commitment to growing me as a person and scholar. I have learned several life lessons while working with you and this has allowed me to succeed in schooling as well as in life.

To Danielle DeVries, Jeff Lidstone, Paul Leuty and all my lab mates, thank you for your support and patience as we all advanced through our courses and lab work. It was a pleasure getting to know each and every one of you. Danielle thank you for working with me as we recruited participants and spent several hours in the lab collecting and processing the data. Also, thank-you to Don Clarke for all of the help you have given me in the lab. This study could not have been completed without your knowledge and expertise.

Lastly, I would like to thank my wife Natalie for providing the support and push needed to finish my schooling while living in a great home. Making sure I always came home to a clean house and full fridge. I cannot say enough how much I appreciate the sacrifices you have given me over the past few years. I can't wait to see what the next years bring to you, Ruby and me.

TABLE OF CONTENTS

| | |
|---|------|
| DECLARATION OF ORIGINALITY | iii |
| ABSTRACT..... | iv |
| ACKNOWLEDGEMENT | v |
| LIST OF FIGURES | viii |
| LIST OF APPENDICES..... | xii |
| LIST OF ABBREVIATIONS..... | xiii |
| Chapter 1: INTRODUCTION..... | 1 |
| 1.1 BACKGROUND..... | 1 |
| 1.2 STATEMENT OF THE PURPOSE..... | 3 |
| 1.3 HYPOTHESES | 3 |
| Chapter 2: LITERATURE REVIEW..... | 7 |
| 2.1 TOOLS | 7 |
| 2.1.1 TOOL TYPES | 7 |
| 2.1.2 PNEUMATIC POWER TOOLS..... | 8 |
| 2.1.3 DIRECT-CURRENT POWER TOOLS..... | 9 |
| 2.1.4 HAND PLACEMENT..... | 12 |
| 2.2 JOINTS..... | 17 |
| 2.2.1 JOINT TYPE..... | 17 |
| 2.2.2 JOINT TIGHTENING STRATEGIES..... | 17 |
| 2.3 WORKSTATION DESIGN..... | 22 |
| 2.3.1 FASTENER LOCATION | 22 |
| 2.3.2 POSTURES | 23 |
| 2.4 FORCES..... | 24 |
| 2.4.1 HAND/HANDLE FORCES..... | 24 |
| 2.5 Handle Displacement | 26 |
| 2.5.1 DISPLACEMENT-VELOCITY-ACCELERATION | 26 |
| 2.6 MOTION CAPTURE..... | 30 |
| 2.7 SUBJECTIVE RATINGS | 33 |
| 2.8 RATINGS OF PERCEIVED EXERTION USING POWER TOOLS | 35 |
| Chapter 3: METHODS | 37 |
| 3.1 PARTICIPANTS..... | 37 |

| | |
|--|-----|
| 3.2 INSTRUMENTATION AND DATA ACQUISITION | 38 |
| 3.3 EXPERIMENTAL PROCEDURE AND PROTOCOL..... | 40 |
| 3.4 DATA ANALYSIS | 43 |
| 3.5 STATISTICAL ANALYSIS | 44 |
| Chapter 4: RESULTS | 44 |
| 4.1 HANDLE DATA | 44 |
| 4.1.1 IMPULSE..... | 44 |
| 4.2 JOINT ANGLES | 53 |
| 4.2.1 ARM ADDUCTION | 53 |
| 4.2.2 ARM FLEXION..... | 55 |
| 4.2.3 ARM ROTATION..... | 60 |
| 4.2.4 ELBOW FLEXION..... | 61 |
| 4.3 BORG RATINGS | 68 |
| Chapter 5: DISCUSSION | 74 |
| 5.1 HANDLE FORCE IMPULSES | 74 |
| 5.2 JOINT ANGLES | 76 |
| 5.3 HANDLE DISPLACEMENT | 78 |
| 5.4 SUBJECTIVE RATINGS | 79 |
| 5.5 HYPOTHESES REVISTED | 80 |
| Chapter 6: CONCLUSION | 83 |
| 6.1 LIMITATIONS AND ASSUMPTIONS..... | 83 |
| 6.2 IMPLICATIONS FOR INDUSTRY..... | 85 |
| 6.3 FUTURE RESEARCH DIRECTIONS..... | 86 |
| REFERENCE LIST | 87 |
| APPENDIX A..... | 94 |
| APPENDIX B | 95 |
| APPENDIX C | 98 |
| APPENDIX D..... | 100 |
| APPENDIX E | 101 |
| VITA AUCTORIS | 104 |

LIST OF FIGURES

| | |
|---|----|
| Figure 1: Atlas Copco pistol grip power tool (Atlas Copco, 2014b) | 11 |
| Figure 2: Atlas Copco inline power tool (Atlas Copco, 2014a) | 11 |
| Figure 3: Atlas Copco right angle power tool (Atlas Copco, 2014c) | 11 |
| Figure 4: Single-stage joint tightening strategy (Atlas Copco Industrial Technique AB, 2013) | 13 |
| Figure 5: Two-Stage joint tightening strategy (Atlas Copco, 2005)..... | 14 |
| Figure 6: TurboTight(R) tightening strategy (Atlas Copco, 2013)..... | 15 |
| Figure 7: Right angle power tool hand placement (Kihlberg, Kjellberg & Lindbeck, 1994) | 16 |
| Figure 8: Spindle head angle versus torque level for both hard and soft joints (International Standards Organization, 1994)..... | 19 |
| Figure 9: Example of a reaction bar placed near the spindle head of a right angle power tool (Ingersoll Rand, 2008)..... | 22 |
| Figure 10: Forces occurring during right angle power tool operation (Lin et al., 2003a) | 25 |
| Figure 11: Percentage of operator acceptance compared to displacement (left) and discomfort ratings (right) (Kihlberg et al., 1994) | 28 |
| Figure 12: A) Inertial motion capture suit (Cloete & Scheffer, 2008), (B) Magnetic sensors (Roetenberg, 2006), (C) Optical motion capture suit (Kurihara, Hoshino, Yamane, & Nakamura, 2002), and (D) Mechanical motion capture suit (META Motion, 2014) | 33 |
| Figure 13: Borg’s Category-Ratio 10-point scale (Borg & Borg 2002) | 35 |

| | |
|---|----|
| Figure 14: Modified Borg 10-point scale used to determine participant exertion levels (Borg, 1982)..... | 38 |
| Figure 15: Instrumented handle 3D linear sensor directions | 39 |
| Figure 16: Independent variable matrix | 41 |
| Figure 17: Locations of the four joint location-orientations Location 1: Chestdown, Location 2: Thighdown, Location 3: Hightowards, Location 4: Waistdown | 42 |
| Figure 18: TSS tightening strategy identification of torque initiation, peak torque, tool shut-off and impulse. | 46 |
| Figure 19: Average force impulse (F_x) while operating TS, TSS and TT comparing target torque, and posture. Showing significant reduction in force impulse while operating TT.. | 49 |
| Figure 20: Average force impulse F_x , comparing the three tightening strategies between three increasing target torques as well as hard and soft joints. Significant reduction is found when operating hard joints as well as soft joints..... | 50 |
| Figure 21: Average force impulse F_x , comparing the three tightening strategies between posture and joint hardness. Soft and hard joints showed a reduction in force impulse while using TT compared to TS and TSS..... | 51 |
| Figure 22: Average Force F_y , comparing tightening strategy at the three target torques withiing hard and soft joint operation. TT resulted in the least handle force impulse at each target torque regardless of joint hardness..... | 52 |
| Figure 23: Average shoulder adduction angular displacement measured between torque initiation and 100 ms post target torque. TT results in the least displacement while operating on hard joints. | 56 |

Figure 24: Average arm flexion angular displacement measured between torque initiation and 100 ms post target torque, comparing tightening strategies and target torques while fastening on hard and soft joints. 57

Figure 25: Average arm flexion angular displacement measured between torque initiation and 100 ms post target torque, comparing postures and tightening strategies while operating on hard and soft joints. Regardless of posture, greater displacement was found with increasing target torque..... 59

Figure 26: Average arm rotation angular displacement measured from torque initiation to 100ms post target torque, comparing tightening strategy and posture within hard and soft joint operation. Significantly less displacement was found while operating TT on all postures except hightowards. TSS showed the greatest advantage in hightowards posture.. 62

Figure 27: Average arm rotation angular displacement measured from torque initiation to 100ms post target torque, comparing target torque within each posture operating on hard and soft joints. Angular displacement was shown to increase with greater target torque regardless of operator posture. 63

Figure 28: Average arm rotation angular displacement measured from torque initiation to 100ms post target torque, comparing tightening strategy during operation on hard and soft joints using increasing target torques. TT strategy was shown to have significantly less displacement compared to TS and TSS on hard joints. 64

Figure 29: Average elbow flexion angular displacement measured from torque initiation to 100ms post target torque, comparing target torque and posture within hard and soft

joint operation. Increasing torque was found to lead to increased angular displacement regardless of posture and joint hardness. 66

Figure 30: Average elbow flexion angular displacement measured from torque initiation to 100ms post target torque, comparing tightening strategy and posture within hard and soft joint operation. Operating on hard joints resulted in significantly less displacement while operating TT. Soft joints showed limited differences regardless of posture. 70

Figure 31: Average elbow flexion angular displacement measured from torque initiation to 100ms post target torque, comparing tightening strategy and target torque within hard and soft joint operation. Hard joint operation resulted in significantly less displacement while operating TT strategy compared to TS and TSS. 71

Figure 32: Subjective ratings for all participants comparing tightening strategies and target torque on hard and soft joints. TT resulted in the lowest ratings regardless of target torque on hard and soft joints. 72

Figure 33: Average subjective ratings comparing tightening strategies within each of the four postures. TT resulted in lower discomfort ratings compared to TS and TSS regardless of posture. 73

LIST OF APPENDICES

| | |
|---|-----|
| APPENDIX A. Script..... | 108 |
| APPENDIX B. Consent to Participate in Research Form..... | 109 |
| APPENDIX C. RAPT physical demands data collection sheets..... | 113 |
| APPENDIX D. Questionnaire used for identification of preexisting MSDs..... | 114 |
| APPENDIX E. Placement and location of motion capture markers..... | 115 |

LIST OF ABBREVIATIONS

CR: Category Ratio

DC: Direct-Current

ISO: International Standard Organization

ms: milliseconds

Nm: Newton Meters

N-s: Newton Seconds

RAPT: Right Angle Power Tool

RPM: Revolutions per minute

SIMM: Software for Interactive Muscle Modelling

STD: Standard Deviation

TT: TurboTight®

TS: Two-Stage

TSS: Two-Stage with Soft Stop

Chapter 1: INTRODUCTION

1.1 BACKGROUND

Automotive assembly operations using fasteners to secure parts are commonly associated with right angle power tool operation. According to Radwin, VanBergeijk and Armstrong (1989), Ford motor company estimated 75 percent of all power hand tools used in production involve nutrunners, also known as right angle power tools (RAPT). Recent data have shown that musculoskeletal injuries are commonly associated with power tool operation. In 2012, there were 40,760 hand tool-related injuries in US private industry according to the Bureau of Labor Statistics (2012). This number increased to 42,480 in 2013 (Bureau of Labor Statistics, 2013). These numbers indicate the necessity of research involving hand tool safety.

During automotive assembly, parts are commonly secured using right angle power tools to fasten bolts and nuts using high torques. Right angle power tools are designed with long handles which allow for a greater mechanical advantage when operating at high torques as opposed to pistol grip or inline power tools (Freivalds & Eklund, 1993). Power sources for right angle power tools in the past have mainly involved high pressure air (pneumatic). However, as technology advances, electrically (direct current) powered right angle tools are becoming the standard. Direct current (DC) power tools allow for increased specialization through modification of target torques, rundown profiles and joint type.

In order to identify the risk factors associated with right angle power tool operation, one must understand the interaction between the power tool and operator.

While operating right angle power tools to secure two or more parts, forces develop as a result of the fastening of a joint. During fastening, forces are passed from fastener to the RAPT handle which is held by the operator. Forces experienced by the operator are believed to be equal to the force applied at the joint multiplied by the length of tool handle (Lindqvist, 1993). If the operator does not provide enough force to the tool handle, handle displacement occurs. Once force experienced at the handle exceeds the operator's strength the chance of an upper extremity injury increases and can be further augmented with awkward postures and fatigue (Kim, 2012)

Past research involving right angle power tools have predominantly viewed the effects of reaction torque, handle displacement, hand forces and subjective ratings associated with pneumatic power tool operation. Many of these studies have investigated the influence of torque reactions on a number of parameters including pre-set torque level, run down speed, stiffness of the joint, shut-off mechanism and operator posture (Lindqvist; 1993, Kihlberg, Kjellberg, Lindbeck, 1993, 1994, 1995). In addition, physical capabilities of operators using pneumatic right angle power tools have been established based on mathematical modelling, subjective ratings and handle displacement by various researchers (Lin, Radwin, Fronczak, & Richard, 2003a; Lin, Radwin, & Richard, 2003). Lin, Radwin, Richard and Fronczak (2003b) developed a static and dynamic model for predicting operator response to impulsive torque reaction forces produced by rotating spindle power handle tools based on stiffness, mass moment of inertia and damping elements corresponding to the mechanical characteristics of the operator. Right angle power tool research conducted by Kihlberg, Kjellberg and Lindbeck (1995) has resulted in the development of acceptability limits for pneumatic right angle power tools based on

subjective ratings and handle displacements of participants. Although the research has produced valuable information in regards to right angle pneumatic power tool use, a lack of research on electrically powered right angle tools is of growing concern.

1.2 STATEMENT OF THE PURPOSE

The purpose of the current study was to evaluate the physical demands associated with three direct-current (DC) right angle power tool tightening strategies at various fastener location-orientations, target torques and joint types. With a number of manufacturing companies making a switch from pneumatic to DC powered tools, comparison between the tightening strategies is warranted. Several researchers have studied pneumatic power tool usage, however very few have used electrically powered right angle power tools. Through the findings of this study, researchers will have a better understanding of the physical demands associated with different DC tightening strategies. Furthermore, the findings provide empirical evidence on which tightening strategy provides the least demand on operators, in hopes of limiting the risk of injury associated with DC right angle power tool usage.

1.3 HYPOTHESES

1) Elbow displacement (surrogate of handle) will show a statistically significant ($p < 0.05$) interaction between fastening strategy and target torque measured from initiation of torque to 100 ms post peak torque.

Handle displacement is caused by a build-up of reaction forces developed during joint fastening. Assuming an operators hand, forearm and arm consist of three linked rigid segments, we can predict that handle displacement will result in angular displacement of

the elbow joint. Researchers have studied the effects of torque and tool shut-offs on reaction forces and handle displacement during pneumatic right angle power tool operation. Oh and Radwin (1997) used a single pneumatic power tool with fastening torques of 25, 40, 55 Nm and determined that the operator's ability to control handle displacement decreased as torque reaction forces increased. Furthermore, Oh and Radwin (1994) found greater handle displacement occurred when operating right angle tools on vertical workstations compared to operation on horizontal work surfaces. Additionally, Oh and Radwin (1997) found operating right angle power tools near the body in a vertical orientation increased tool stability, while horizontal orientations produced the greatest stability at further distances from the body. This demonstrates the effects of different factors on handle displacement. While past research has predominantly involved pneumatic power tools, it is expected that the current study will show similar findings in DC right angle power tool operators.

2) Shoulder joint angle displacement will show a statistically significant interaction between fastening strategy, target torque and posture as measured from initiation of torque to 100 ms following peak torque.

Research investigating the influence of right angle power tool usage on operator posture has predominantly focused on biomechanical modelling. Lindqvist (1993) developed a mass-spring model for the hand-arm system in order to identify the effect of RAPT usage. Lin, Radwin and Richard (2003) modelled power tool operators as a single-degree-of-freedom dynamic mechanical system in order to predict operator response to torque reaction force impulses. Human operators were modelled using mass, spring and damping elements to determine operator joint stiffness. In biomechanical models, the

interaction between the hand-arm system and power tool can be affected by the torque reactions resulting from right angle power tool use. Lin, McGorry, Dempsey and Chang (2006) determined greater tool displacement occurred when the tool was held 30 cm below elbow height and operated on a horizontal surface. As handle displacement occurs, the operator hand-arm system must be altered to accommodate the resulting displacement. Therefore, findings should show shoulder joint angle displacements (shoulder abduction/adduction, flexion/extension, rotation) show significant differences between tightening strategies, target torques and operator posture.

3) Subjective ratings will be greater for DC TSS compared to DC TS and DC TT fastening strategies ($p < 0.05$).

Subjective ratings have been used to identify differences of handle displacement and reaction forces produced during right angle power tool operation (Kihlberg, Kjellberg, & Lindbeck, 1995). Results from Kihlberg, Kjellberg, & Lindbeck (1995) determined that any participant who identified with a subjective rating of 9 or higher on a CR-20 Borg scale would not accept to operate a tool which resulted in greater than 6cm of handle displacement and resulting reaction forces. In comparison, if the handle displacement and reaction forces experienced by the participant resulted in a rating of 2 or lower on the CR-20 scale, all participants accepted the task. Furthermore, in order for 90% of all operators to accept a job using a right angle power tool, handle displacement of less than 3 cm was required. Based on Kihlberg, Kjellberg and Lindbeck's studies, participants will provide higher subjective ratings while operating at higher torques, and while experiencing increased handle displacement and handle forces.

4) Force impulse magnitudes occurring between initialization and target torque will be statistically lower ($p < 0.05$) when fastening the DC TT right angle power tool compared to DC TSS and DC TS fastening strategies.

According to Freivalds and Eklund (1993), the impulse of reaction torque is a more appropriate measure than peak torque when viewing reaction forces. This is due to impulse accounting for peak torque as well as the duration of reaction torques during a tool rundown. Research has shown impulse is influenced by tool power levels, torque levels, tightening strategies and joint stiffness (Kihlberg, Kjellberg & Lindbeck 1993, 1994, 1995; Ku, Radwin & Karsh, 2007; Lin & McGorry, 2009). If an underpowered tool is used to tighten a joint, an increase in time to peak torque will result, thus leading to an increased impulse (Freivalds & Eklund, 1993). The process by which a joint is fastened is known as the tightening strategy. Pneumatic power tool tightening strategies work as an on/off principle. Therefore, if the trigger is pulled, the spindle head will rotate until a joint is secured. Pulse tools operate by providing multiple bursts of power to tighten a joint. DC power tools work in a similar fashion to pulse tools where torque profiles allow for different levels of torque to be applied during a run down. Based on these principles, the DC TurboTight® strategy will provide statistically lower impulse reaction forces compared to DC single-stage and DC Two-Stage power tools.

Chapter 2: LITERATURE REVIEW

2.1 TOOLS

2.1.1 TOOL TYPES

During automotive assembly, operators use power tools, either powered pneumatically (air) or electrically using Direct-Current (DC), to help secure various parts. Traditionally, pneumatic tools have been the most common power tools used. However, as technology evolves, automotive manufacturers have gradually replaced pneumatic tools with DC based power tools. DC tools can be outfitted with transducers, allowing tool angle and torque recordings for greater control and feedback from each fastening. Furthermore, tool recordings can be used as feedback to reduce injury risk in addition to ensuring product quality.

Tool manufacturers produce pneumatic and DC power tools in various shapes and sizes including pistol grip, inline and right angle configurations. Pistol grip (Figure 1) and inline (Figure 2) tools are best used on low torque run downs, while completing fastenings located on vertical and horizontal surfaces, respectively. Fastenings requiring high torques primarily involve right angle power tools, regardless of orientation. As shown in Figure 3, right angle power tools with long handles provide operators with a mechanical advantage. The mechanical advantage, created by the increased moment arm from hand to pivot point, allows the operator to exert less force to counteract the moment created during joint fastening (Radwin, Vanbergeijk, & Armstrong, 1989). Furthermore, Radwin, Chourasia, Howery, Fronczak, Yen, Subedi & Sesto (2014), state that the ideal method to determine tool selection should consider the performing task, workstation

design, tool characteristics and human operator capacity. This review will focus on right angle power tools only.

2.1.2 PNEUMATIC POWER TOOLS

Pneumatic power tools use air pressure to generate spindle head torque to utilize in the fastening of a joint. The pull of a trigger allows an influx of air, causing the gear mechanisms in the tool to move, resulting in rotation of the spindle head. The air pressure and gear settings determine the constant velocity maintained by the spindle head rotation. Pneumatic power tools maintain spindle head rotation until the flow of air ceases due to the release of a trigger. Consequently, the operator must resist all reaction forces created during joint fastening while the trigger is initiated (Kihlberg, Kjellberg, & Lindbeck, 1993). If the operator does not release the trigger, extended exposure to the reaction forces may result in increased risk of injury. However, outfitting pneumatic tools with feedback mechanisms allows for pre-set shut-off to occur.

In order to limit forces experienced by operators using pneumatic power tools, Radwin, VanBergeijk and Armstrong (1989) identified two pneumatic shut-off mechanisms: stall and clutch. The first mechanism, stall shut-off, occurs following the rundown phase once a set torque resistance occurs. At the pre-set resistance, the tool stalls and the operator releases the throttle ensuring joint fastening is complete. Radwin, VanBergeuk & Armstrong (1989) found stall tools tended to have the longest torque reaction times, resulting in the operator experiencing the greatest reaction force. In comparison, Lin, Radwin, Fronczak, and Richard (2003b) found the maximum torque produced by a pneumatic power tool occurs once the motor stalls.

The second pneumatic power tool shut-off mechanism identified by Radwin, VanBergeuk and Armstrong (1989) is a mechanical clutch. Mechanical clutches involve disengaging tool air supply once a pre-set torque level is met (Schulze, Congleton, Koppa, & Huchingson, 1995). Lindqvist (1993) determined that the use of a mechanical clutch, which disengages at a pre-set low torque, followed by a slow increase and decrease of spindle head speed, leads to minimal torque reaction when using right angle power tools.

2.1.3 DIRECT-CURRENT POWER TOOLS

Direct-Current power tools operate in a similar fashion to pneumatic tools. However, once the operator engages the trigger of a DC tool, an electrical current powers a motor, leading to spindle head rotation. In addition, DC tools are equipped with transducers, allowing for the recording of fastener rotation angle and magnitude of output torque during joint securing phases (Potvin, Agnew, & Ver Woert, 2004). The use of transducers provides manufacturing engineers and ergonomists extensive feedback information pertaining to: tool usage, joint fastening, operator efficiency and other relevant information relating to individual workstations.

Unlike pneumatic power tools, tightening strategies for DC tools are completely programmable. Individual programs allow the control of the electrical motor speed at any given angle or time during a fastening run down. A run down is initiated when the operator engages the tool trigger, causing a brief spike on the torque output signal as the fastener is tightened, and is completed once the fastener and joint are firmly connected (Radwin et al., 1989). Snug fit is the commonly referred term for this firm connection. Following run down, the torque build-up phase begins. Direct-Current joint fastening

commonly involves Single-Stage or Two-Stage tightening strategies. A single-stage tightening strategy, as shown in

Figure 4, begins with a free spinning spindle head until reaction torque begins to build. Once the resistance occurs, the spindle head increases to a top speed, and ends once the tool shut-off following the reaching of target torque. A Two-Stage tightening strategy, shown in Figure 5, is identified as a free spinning spindle head, followed by an increase to a high speed, pause for ~50 ms, then a final increase to a lower spindle head speed until the final target torque is reached.

Atlas Copco's Quickstep is a version of a Two-Stage tightening strategy. Quickstep profiles display a high torque following a spindle head's initial resistance, followed by a second stage in which maintains a lower spindle head rotation speed until the final target is met (Atlas Copco, 2005). Unlike the Two-Stage tightening strategy, the Quickstep profile does not have a pause between stages one and two. A slight variation to Atlas Copco's Quickstep is the DC-Ergo ramp. The DC-Ergo ramp is also a Two-Stage strategy in which a constant increase in torque occurs during the second stage. This torque can be automatically set based on an input value and joint hardness. An advantage of this strategy is the operator experiences similar reaction torques for both soft and hard joints.

A tightening strategy known as TurboTight[®] (Figure 6) has been developed that differs from both single-stage and Two-Stage tightening strategies. TurboTight[®] uses the input of final torque, fastening angle or target torque and torque rate to calculate the required energy to fasten a joint (Atlas Copco, 2013). TurboTight[®] implementation has shown to reduce reaction forces as well as reduce cycle times (Atlas Copco, 2013).



Figure 1: Atlas Copco pistol grip power tool (Atlas Copco, 2014b)



Figure 2: Atlas Copco inline power tool (Atlas Copco, 2014a)



Figure 3: Atlas Copco right angle power tool (Atlas Copco, 2014c)

While most researchers identify the main risk of injury being the end of the torque build-up phase, others have also identified the return to zero torque as an issue. Atlas Copco's Soft Stop function works to reduce the end "jerk" associated with right angle power tool operation. Soft Stop works by sensing the final target torque and providing a series of off/on steps to achieve tool shut-off. Shutting off the tool, and turning it back on for short periods of time, creates a gradual shut-off, which leads to reduced jerk.

2.1.4 HAND PLACEMENT

During right angle power tool use, hand displacement and reaction forces occur. The placement of an operator's hand on the tool can influence the magnitude of hand reaction forces and handle displacement. It is common in the literature for the operator's right hand to be placed on the tool handle and the left hand palm placed above the spindle head, (Figure 7), (Kihlberg, Kjellberg and Lindbeck studies, (1993, 1994 and 1995). Using this hand placement, the right hand controls the trigger and the power source. The left hand, placed above the spindle head, helps control the tool and prevents the spindle head from slipping off the joint. Radwin, Chourasia, Howery, Fronczak, Yen, Subedi and Sesto (2014) and Lindqvist (1993), instructed their participants to place a hand on the trigger and grasp the tool near the spindle head with the other hand, rather than placing it on top of the tool. Lin, McGorry, Chang, and Dempsey (2007); and Lin, McGorry, & Chang, (2007) used a single hand to operate a right angle power tool, which was placed on a simulated handle, offset from the tool. Single hand power tool use was acceptable due to the low torques (< 26 Nm) performed in the study.

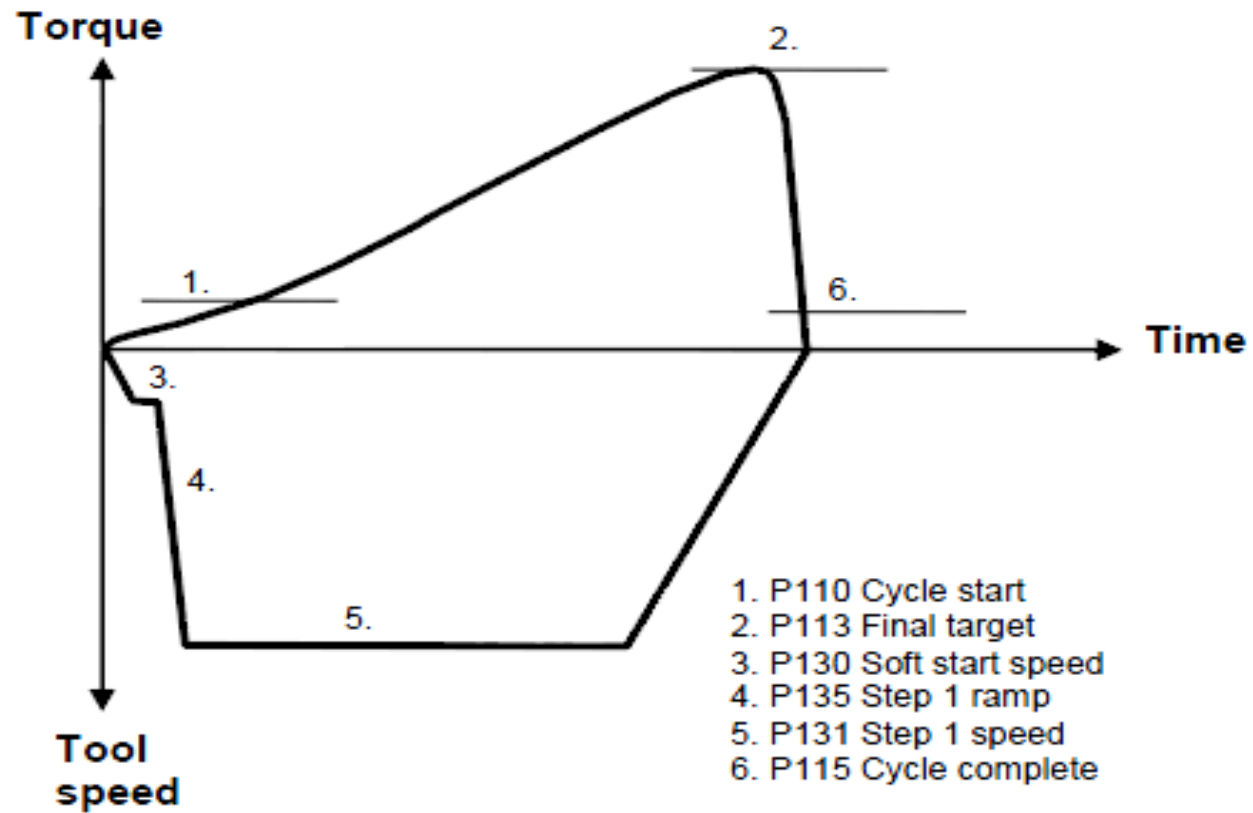

Figure 4: Single-stage joint tightening strategy (Atlas Copco Industrial Technique AB, 2013)

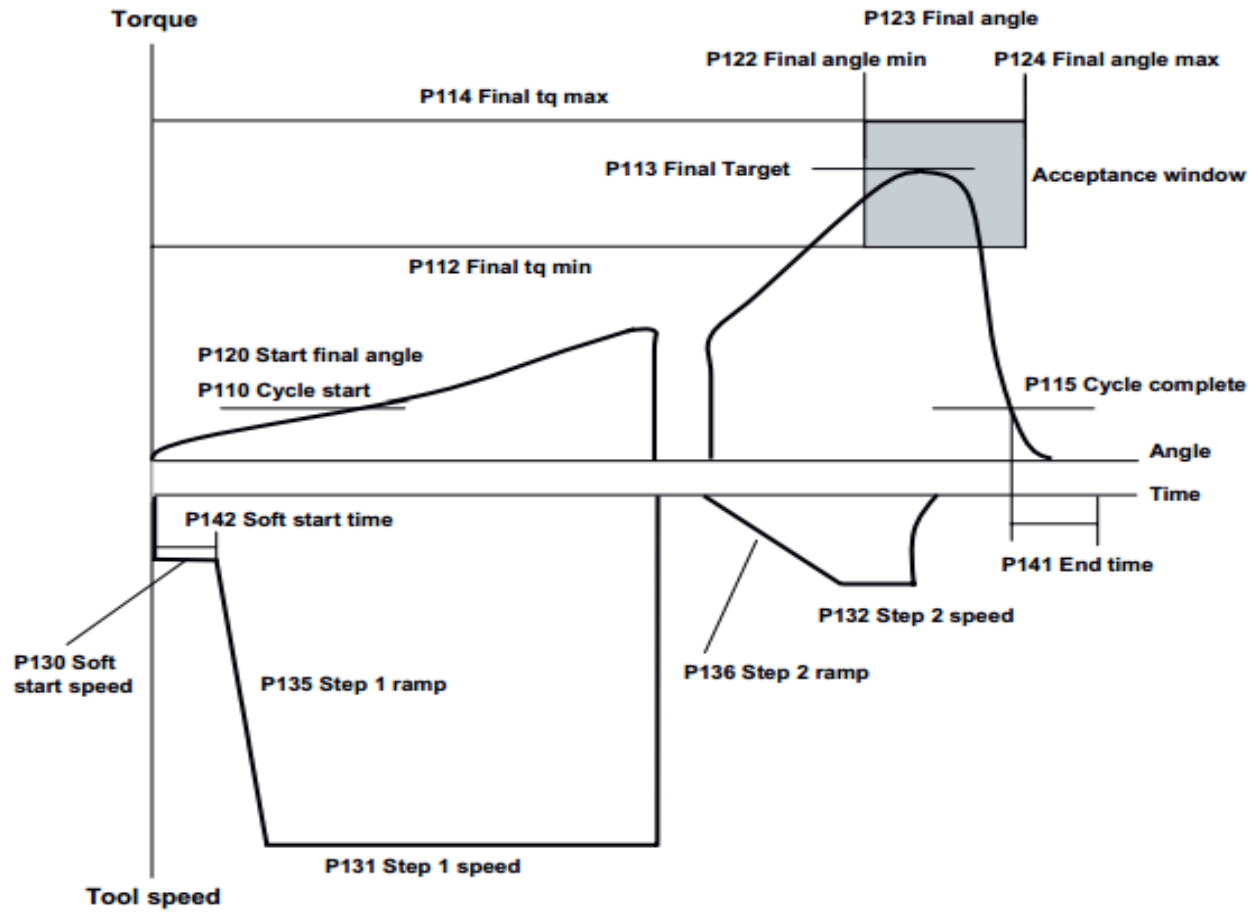

Figure 5: Two-Stage joint tightening strategy (Atlas Copco, 2005)

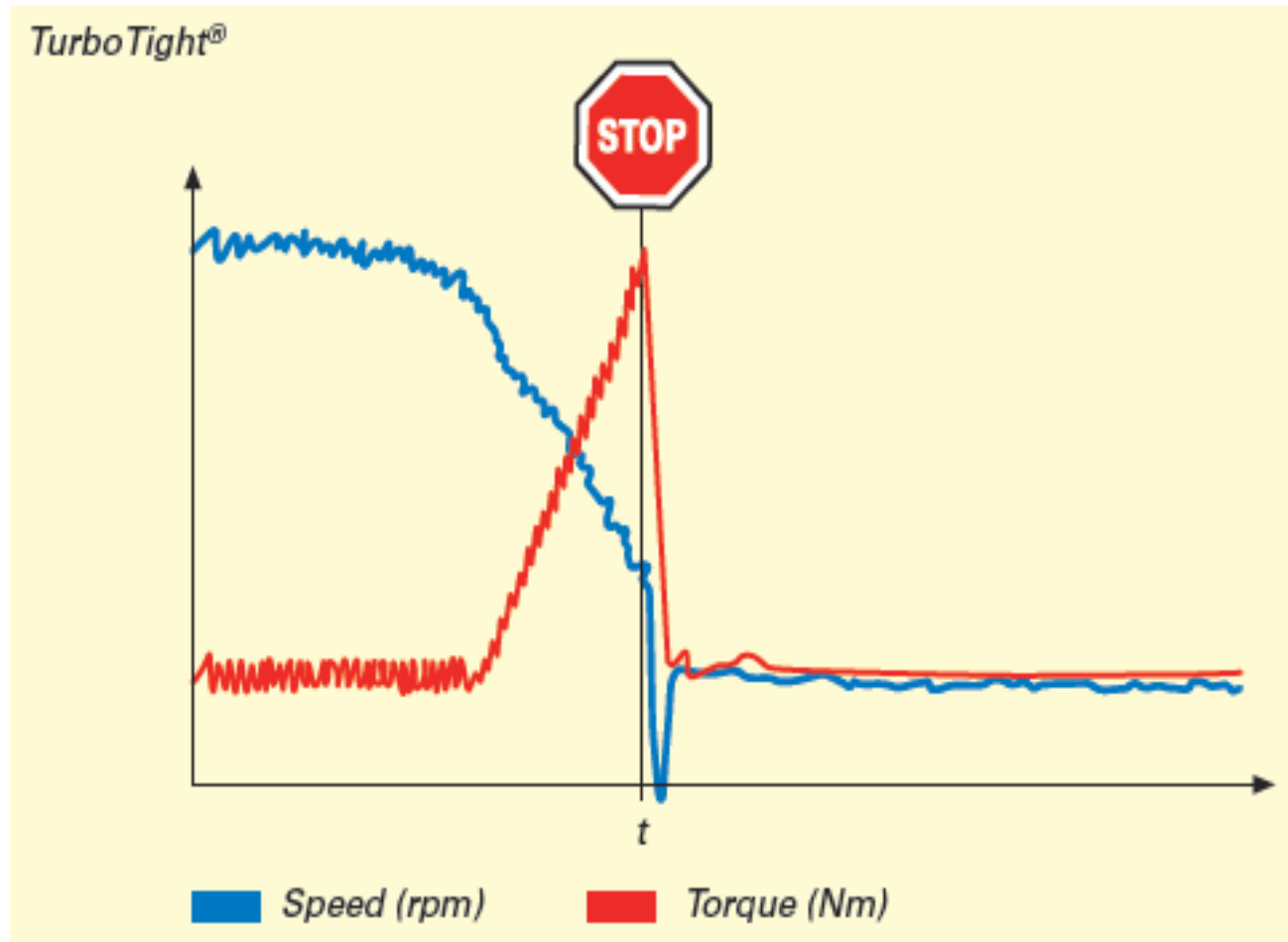

Figure 6: TurboTight® tightening strategy (Atlas Copco, 2013)

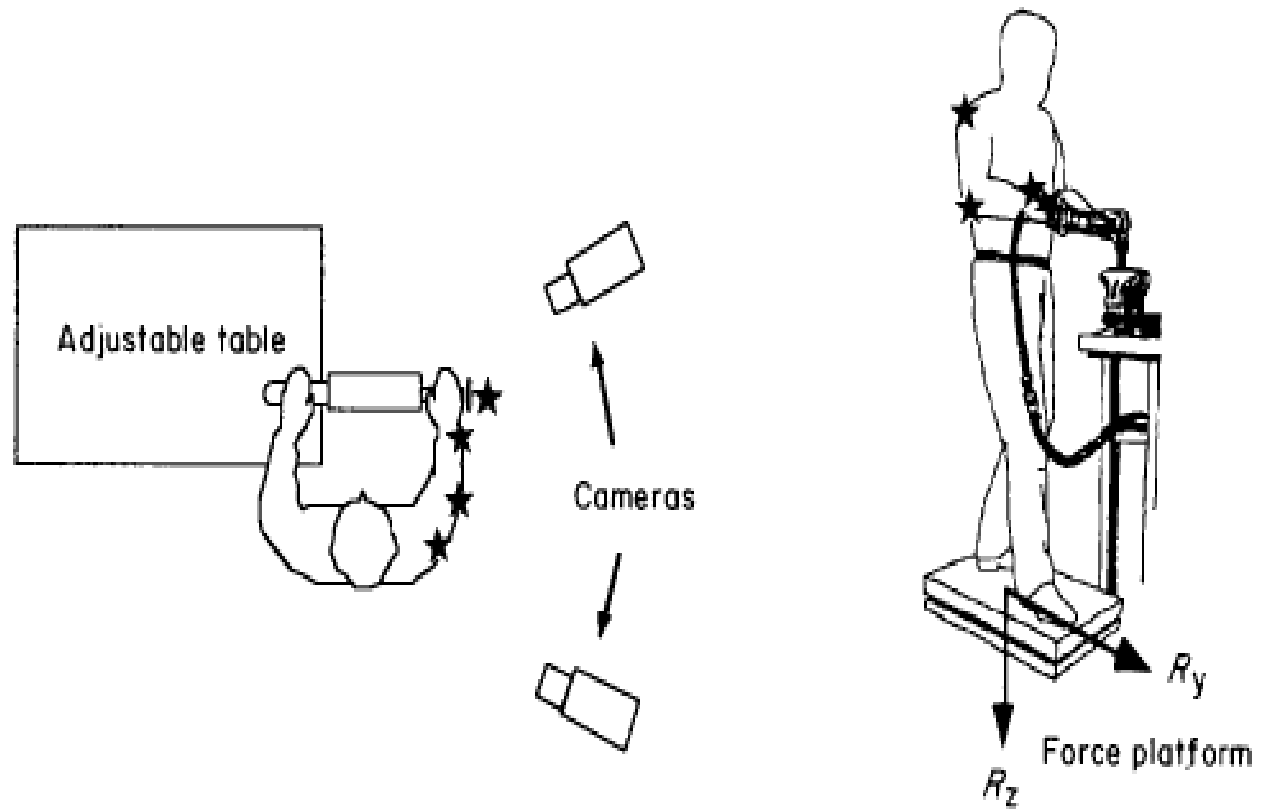

Figure 7: Right angle power tool hand placement (Kihlberg, Kjellberg & Lindbeck, 1994)

2.2 JOINTS

2.2.1 JOINT TYPE

In automotive assembly, a joint is identified as two or more parts secured together by a one or more fasteners. Classification of joints using the torque rate or the spindle head rotation required to secure the joint from snug fit to target torque are common (Lin et al., 2006; Radwin et al., 1989). The two main classifications of joints are “hard” or “soft” in manufacturing and automotive assembly (Figure 8). The International Organization for Standardization (ISO) power tool standard ISO 5393 defines a hard joint as a torque increase from 10% to 100% of target torque within an angular displacement of 27° and, the transition angle from 5% to 10% should not exceed 10° . The ISO definition of a soft joint is a torque increase from 10% to 100% of total torque with an angular displacement of no less than 650° and an increase from 0 to 100% resulting in an angle of no less than 720° . Times associated with hard and soft joints range from 0 to 0.5 seconds and up to 2 seconds, respectively (Radwin et al., 1989)

2.2.2 JOINT TIGHTENING STRATEGIES

Right angle power tool joint tightening strategies, such as single-stage and Two-Stage tightening, consist of three phases: initial rundown, torque build-up, and shut-off.

2.2.2.1 RUNDOWN

The initial rundown phase begins when the trigger initiates spindle head rotation, leading to the rotation of a fastener. The spindle head rotates the fastener, at low speeds until it comes into contact with an opposing surface. A connection between the fastener and surface causes the fastener and joint to fit snugly, leading to the torque build-up phase.

During the rundown phase, tool torque build-up is near zero and limited handle movement occurs (Radwin et al., 1989).

2.2.2.2 TORQUE BUILD-UP

As the two surfaces come into contact and reach snug fit, the torque build-up phase begins. During build-up, a continuous rotation of the fastener causes the two materials to connect, producing friction and an increase in resistance, initiating the mating of the materials. As resistance builds, the operator must provide a force to the tool handle, believed to be equal to the rotational force (torque) divided by the length of hand to spindle head, to ensure joint fastening (Lindqvist, 1993). If the operator does not provide adequate force to the handle, the tool will spin freely around the joint. Therefore, by stabilizing the handle, the operator can direct the forces from the power tool into the joint, leading to joint fastening. The build-up time, known as the time between rundown and joint secure, typically ranges between 0 to 0.5s and 0 to 2s for hard and soft joints, respectively, while operating pneumatic power tools (Radwin et al., 1989).

While looking at the influence of target torque and build-up time during right angle power tool operation, Oh and Radwin (1998) found increased build-up times lead to longer physical exertions in addition to greater torque impulses. Increased build-up times allow operators the opportunity to make anticipatory postural adjustments to maintain postural control, preventing the tool from jerking and limiting postural disturbance. Massion, Alexandrov, and Frolov (2004), identified three mechanisms for achieving postural control including: joint stiffness, postural reactions and anticipatory postural adjustments.

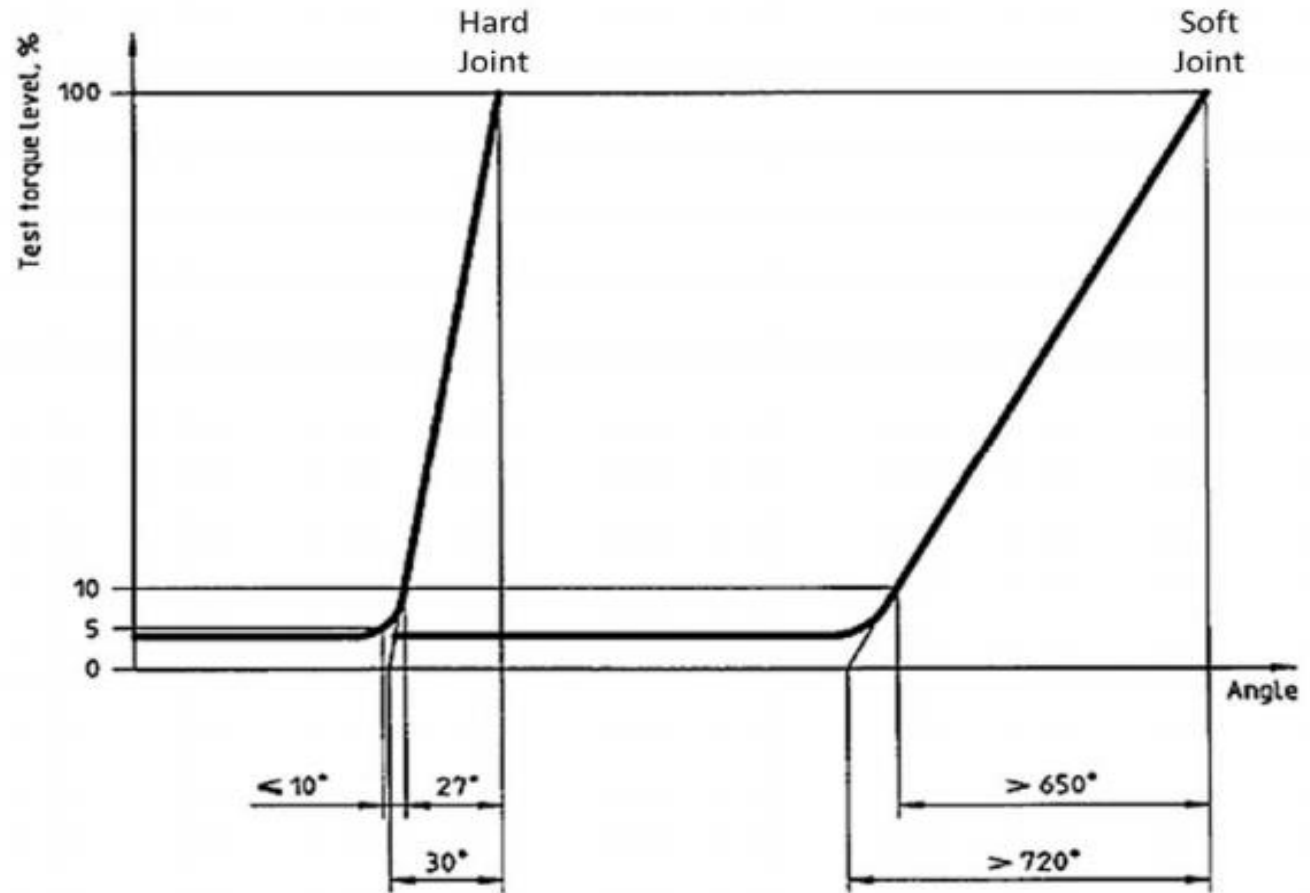

Figure 8: Spindle head angle versus torque level for both hard and soft joints (International Standards Organization, 1994).

Joint stiffness of the shoulder, elbow and wrist, are used to prevent the body from deviating from a predetermined position. Joint stiffness allows power tool users to maintain an identified body position in order to counteract the reaction force developed during power tool usage. If the operator experiences a deviation during tool usage, he/she may use feedback to reduce the amount of postural disturbance and maintain balance during or following the action. A postural reaction occurs when an individual uses feedback to maintain a specified posture.

Massion (1992) defines anticipatory postural adjustments as an alteration that occurs prior to the onset of a disturbance to an individual's posture or equilibrium, and results from an internal voluntary command (E.g., an operator who changes body position to stabilize his/her posture prior to operating a power tool with high torque settings). If the postural adjustment is due to an external input, for example power tool displacement, the adjustment is no longer in anticipation of the event and can be identified as a postural reaction (Massion, Alexandrov, & Frolov, 2004).

Industry and manufacturer specifications determine the amount of tool torque required to secure a joint between two or more materials. In the automotive industry, certain securing tasks mandate high torque fastenings to ensure user safety and manufacturer reliability. These require operators to exert large forces into the handle in order to counteract the high torque; ensuring limited handle displacement and proper fastening occurs. In order to prevent handle displacement, operators must use their arms, legs and full body weight in certain instances, which may contribute to an increased risk of developing injuries. Implementation of torque reaction bars may reduce the physical demand associated with high torques. Torque reaction bars are solid support structures

mounted on power tools, which allow for the dispersion of reaction forces created during fastener tightening. A torque reaction bar, (Figure 9), can be outfitted to power tools in workstations that require high torques; limiting operator stress during extreme torque tasks. Forsman, Cyrén, Möller, Kadefors and Mathiassen (2002) found that tasks with torques greater than 100 Nm often use torque reaction bars in order to limit reaction forces experienced by operators. However, a more conservative 55 Nm peak spindle head torque limit, based on research completed by Oh and Radwin (1998), has become an industry standard. Although the use of torque reaction bars helps to reduce high tool reaction forces, it also adds weight to the tool and may require customization. The tool type, workplace orientation, and the performed task all influence the customization of reaction bars. For example, if the task requires an operator to perform a fastening in a crowded engine compartment, the reaction bar must be small enough to fit into a tight space, yet still reduce reaction forces applied to the operator.

2.2.2.3 SHUT-OFF PHASE

Once the joint fastening is complete, tool shut-off occurs. DC right angle power tools use pre-set torques to activate an immediate shut-off mechanism, in an attempt to reduce tool jerk and operator force. The power sources of pneumatic RAPT's work while the trigger is pulled; trigger must be released in order to shut the tool off. However, if outfitted with shut-off mechanisms, pneumatic power tools can terminate at pre-set torque levels similar to DC tools. Research shows that prolonged shut-off mechanisms result in tool operators experiencing greater torque reactions than immediate shut-offs (Kihlberg, Kjellberg & Lindbeck, 1993). Additionally, force demand increases and extended exposure to torque reactions resulted in greater risk of injury over time (Radwin et al., 1989). Kihlberg,

Kjellberg and Lindbeck (1993) studied pneumatic right angle torque reactions using three shut-off mechanisms (Fast, Slow, and Delayed) and found the lowest torque reaction forces occurred when using fast shut-off mechanisms. In addition, fast shut-offs resulted in the smallest handle displacement and wrist motions when compared to slow shut-offs. Furthermore, Kihlberg, Lindbeck and Kjellberg (1994) conducted a similar study using the same shut-off mechanisms, three separate tool torques and nine power tools. They found that the largest reaction torque and handle displacement resulted from the delayed shut-off mechanism. The only tools to experience increased reaction forces as tool torque increased had delayed shut-offs. However, with the phasing out of pneumatic power tools and the implementation of DC tools increasing, tool shut-offs are becoming similar for all tools.

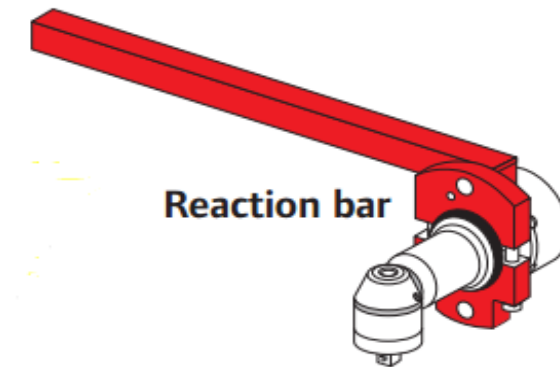

Figure 9: Example of a reaction bar placed near the spindle head of a right angle power tool (Ingersoll Rand, 2008)

2.3 WORKSTATION DESIGN

2.3.1 FASTENER LOCATION

Each individual fastening creates its own specific challenge simply by the location of the joint relative to the operator. Fastener location, often identified by the vertical distance

from the ground and the horizontal distance from the midline of the operator, can influence muscle activity, subjective ratings and tool displacement (Oh & Radwin, 1994; Lin et al., 2006; Oh & Radwin, 1997). Oh and Radwin (1994) reviewed workstation configurations and their effect on tool dynamics. Results showed that the greatest hand displacement using a right angle power tool occurred on surfaces higher than 90 cm above the ground, on both vertical and horizontal work surfaces. Furthermore, vertical workstations resulted in greater hand displacement when compared to horizontal work surfaces. Oh and Radwin (1997) used two power tool orientations (horizontal, vertical) and two tool distances (10 cm, 35 cm) to evaluate the effects of tool dynamics and workstation design on handle kinematics. They found that operators using a vertical tool orientation on workstations close to the body provided the greatest tool stability. The increased tool stability in the near work orientations could be attributed to the mechanical advantage of the hand-arm system in this posture (Lin et al., 2003). Oh and Radwin (1997) also determined that operators working on horizontal workstations experienced greater hand stability while operating at distances further from the body. Therefore, if the rotational force developed by the fastening of two separate joints is equal, the operator with the greatest moment arm (horizontal distance from the body) would require the least amount of force to maintain handle stability.

2.3.2 POSTURES

Operator response to power tool reaction forces during joint fastening can be influenced by a multitude of factors including tool shape, torque settings, work location and work orientation (Lin et al., 2006). As discussed earlier, individuals choose power tool shape based on the fastening type as well as the target torque required to secure the fastener.

High torques are commonly addressed by using right angle power tools, while pistol grip and inline power tools are associated with low torque fastenings. Work location and orientation may also influence the posture by identifying the tool with greatest mechanical advantage. Ulin, Snook, Armstrong and Herrin (1992) conducted a study using three power tool shapes (pistol grip, inline and right angle) to secure screws into perforated sheet metal in various workplace orientations. They determined that tasks performed on vertical surfaces received the lowest subjective ratings while using pistol grip power tools. When working on a horizontal surface, inline tools or right angle power tools resulted in the lowest ratings. As this study will be using right angle tools only, pistol grip and inline tools will be identified for example purposes only.

2.4 FORCES

2.4.1 HAND/HANDLE FORCES

During fastening, right angle power tools develop reaction forces as materials join together. Reaction forces occur during the torque build-up phase and must be met and/or exceeded by the operator in order to limit handle displacement. If handle displacement occurs, the joint may not properly fasten, leading to product safety issues. As shown in Figure 10, typical placement of an operator's hand is above the spindle head. This hand above the spindle head allows the operator to apply a feed force to maintain connection between tool and fastener. During tool operation, an upwards reaction force is produced into the hand as the feed force is directed downward at the joint. Near the distal end of the tool, a trigger hand provides stabilization while also controlling the power source driving the tool. The hand-arm system provides stabilization of the operator and can minimize the handle displacement caused by torque reactions during build-up and shut-

off phases. Build-up and shut-off torque reaction forces produced during securing tasks have been shown to depend on the tool weight, length of tool, and center of gravity (Radwin et al., 1989). Lin, McGorry, Dempsey and Chang (2006) determined operator strength, tool settings and handle length can influence the force response during power tool usage.

As previously discussed, forces provided by the operator must meet or exceed the reaction forces produced at the handle, or handle displacement will occur. The creation of handle displacement through spindle head torque reaction forces is dependent on the angular displacement caused by spindle head rotation and tool length. Therefore, increasing angular displacement caused by spindle head rotation, results in greater handle displacement. Increases in tool length have shown to produce greater torque and greater handle displacements, regardless of joint location (Lin et al., 2006).

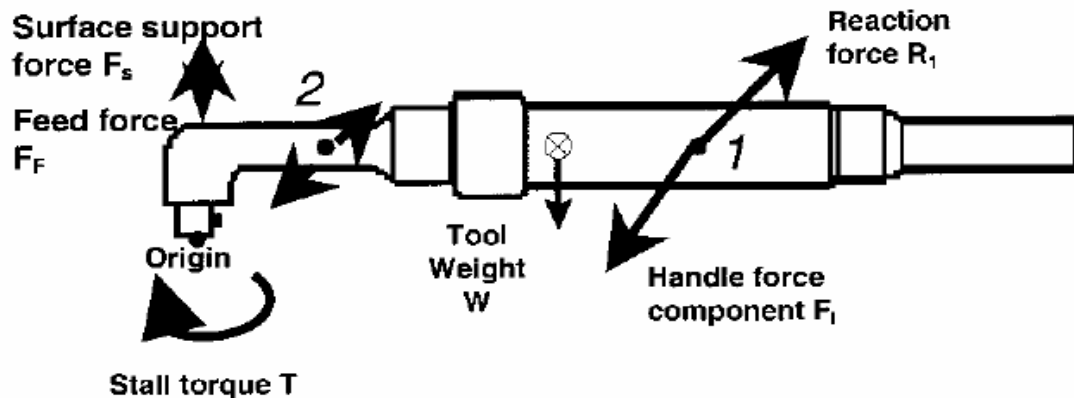

Figure 10: Forces occurring during right angle power tool operation (Lin et al., 2003a)

In the workplace, each task must meet required specifications in order to ensure product reliability and safety. Therefore, if a task requires a right angle power tool with a high torque, the operator will not be able to decrease the reaction forces that he/she will

need to apply, which may lead to a dangerous work environment. Lin, McGorry, Dempsey and Chang (2006) found limiting torque reactions can lead to less displacement and a decrease in risk of injury. Radwin, Vanbergeijk and Armstrong (1989) identified four ways to limit torque reaction forces applied to operators during power tool usage. The first technique is to use a torque reaction bar, similar to the one shown in Figure 9. The second technique is the installation of torque absorbing suspension balancers. Suspension balancers hang from a support structure above the work and remove the weight of the tool from the operator while fastening occurs. Thirdly, tool-mounted nut holding devices allow operators to use both hands to control handle displacement. Lastly, installation of tool support and reaction arms allows for better positioning accuracy and less movement. Implementing these devices can help lower reaction forces and decrease the risk of injury during high torque tasks.

2.5 Handle Displacement

2.5.1 DISPLACEMENT-VELOCITY-ACCELERATION

The build-up of tension during joint fastening can cause handle displacement. This may lead to an increased risk of injury, operator fatigue, as well as inadequate target torques. Failure to meet the target torque creates unsecured fastenings which can result in possible quality control issues. Handle displacement is defined as the net change of handle position during the tool torque build-up phase. The amount of displacement can be determined using the displacement angle, and tool length; often-measured in millimeters (mm) or centimeters (cm) (Kihlberg et al., 1995; Lin & McGorry, 2009; Lin, McGorry, Chang, & Dempsey, 2007). The amount of handle displacement associated with power tool use can be affected by numerous factors including tool shape, joint hardness and

torque speed (Ku, Radwin, & Karsh, 2007). Sesto, Radwin and Richard (2005) found when all other factors are equal, power hand tool reaction forces and tool displacement are greater for right angle power tools with high peak torques and soft joints, than for low torque and hard joints.

Kihlberg, Kjellberg and Lindbeck (1993, 1994 & 1995) conducted a series of studies to determine hand-arm displacement (handle) and participant discomfort during right angle power tool usage. In 1993, reaction forces, hand-arm displacement, muscle activity and subjective discomfort ratings were examined during threaded fastening using three angled power tools and three shut-off mechanisms (fast, slow, delayed). Participants completed five consecutive joint securing tasks with all four power tools, resulting in a total of 20 fastenings. The fast shut-off mechanism was shown to result in the lowest subjective ratings, lowest reaction forces and least handle displacement. In comparison, the delayed shut-off mechanism resulted in the greatest reaction forces and highest subjective discomfort ratings.

In 1994, Kihlberg, Kjellberg and Lindbeck incorporated nine angled power tools, using three torques (25, 50, 75 Nm) and the same three shut-off mechanisms. The fast shut-off mechanism produced the least handle displacement, lowest reaction forces and subjective ratings. Furthermore, results show a positive correlation between subjective discomfort ratings and handle displacement.

Lastly, Kihlberg, Kjellberg and Lindbeck (1995) used their previous findings to develop pneumatic right angle power tool torque acceptability limits. The participants included 38 truck assembly workers, who were required to use three right angle power tools to complete two joint securing repetitions. During rest periods, the participants

provided subjective discomfort ratings. During these times, participants answered if they would accept a full day's work operating a tool that provided a reaction force similar to the one they just experienced. The findings resulted in the development of acceptability limits based on the subjective ratings and handle displacement. The acceptance based on handle displacement in cm can be viewed in Figure 11. A tool displacement of 6 cm resulted in 50% of the operators accepting a full workday. Furthermore, 75% accepted a handle displacement of 4 cm and 90% accepted a displacement of 3 cm. Based on subjective discomfort ratings, 100% of individuals indicated they would work with a rated discomfort of "2" on a 20-point CR scale, and 0% would work with discomfort ratings of "9" or higher.

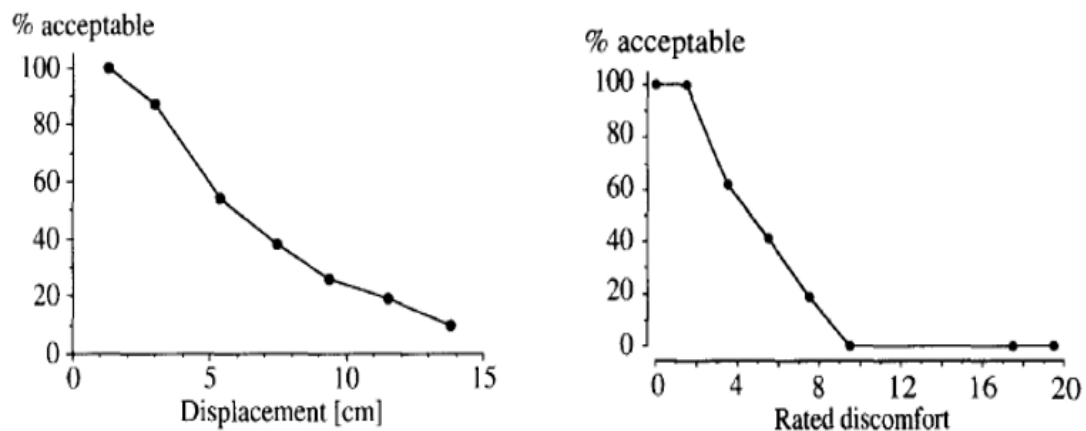

Figure 11: Percentage of operator acceptance compared to displacement (left) and discomfort ratings (right) (Kihlberg et al., 1994)

Handle dynamics during tool operation allow for researchers to identify the effects of handle displacement. Determining handle stability through the use of handle dynamics, handle velocity and acceleration during tool use has resulted in an understanding of operator-tool kinematics. Oh and Radwin (1997) measured handle kinematics (peak handle displacement and peak handle velocity) to quantify the relative

stability of tool handles during joint fastening. Positive velocity occurred if the forces provided from tool torque over powered the operator, causing the handle to rotate away from the operator. If the operator provided sufficient strength to overcome the tool torque, the handle moved closer to the operator's body; movement which was identified as a negative peak velocity. The findings show that as torque reaction forces increased, peak handle displacement and peak handle velocity increased. Therefore, as torque reactions increased, the ability of the operator to control handle displacement decreased. In addition, peak handle velocity decreased with increased joint hardness due to augmented build-up time associated with hard as opposed to soft joints.

When measuring handle displacement in laboratory settings, researchers have used numerous techniques. The simplest and most cost-effective way to measure handle displacement is with a single axis goniometer (Kihlberg et al., 1993; Kihlberg, Lindbeck, & Kjellberg, 1994). Kihlberg, Lindbeck and Kjellberg (1994) compared a goniometer to a more sophisticated measurement system (SELSPOT 3D motion measurement system) and found that a goniometer provided similar results. They concluded that the use of a goniometer during field studies where motion capture use is not available would yield similar results. Also, researchers have implemented accelerometers to measure handle displacement. Lindqvist (1993) fixed an accelerometer to a right angle power tool, and determined handle displacement by integrating the acceleration twice. Lin, Radwin and Richard (2001) developed a single-degree-of-freedom model comprised of mass, moment of inertia, linear rotational springs and viscous dampers, as parameters to predict handle displacement during power tool usage. The model had a tendency to underestimate actual handle displacement as measured by an OptoTrak 3020 3D motion analysis system.

2.6 MOTION CAPTURE

Human motion capturing is associated with the analysis of human movement using cameras and computers. Motion capturing allows for the collection of the kinematics of body segments such as the head, arm and forearm, hands, torso, thigh and shank, and feet in an effort to understand human movement behaviors. Collected motion data allows for the improvement of performance, better understanding behaviors of diseased populations or reducing injuries. Moeslund and Granum (2001) identified three specific areas of application for human motion capturing; surveillance, control, and analysis. As described by Moeslund and Granum (2001), surveillance relates to the monitoring of certain areas or scenes, control is defined as using motion capture as a skeleton or model for another software, and analysis is concerned with clinical studies and diagnostics of motion. The majority of human motion capturing research involves motion analysis, as the goal is to understand human behavior under various circumstances.

Furniss (1999) identified several types of motion capture including mechanical video, magnetic, optical, and inertial. Mechanical motion capture is a technique that uses exoskeleton devices attached to an individual's body. Sensors placed on the exoskeleton above joint centers to determine rotations of each segment during movement. Magnetic capturing consists of magnetic receivers placed in an array on a participant's body which track location with respect to a static magnetic transmitter (Furniss, 1999). While magnetic motion capture produces absolute orientation and positions, a number of interference objects can cause magnetic distortion.

Optical motion capture devices are the most common type used in the field of research due to high sampling rates and limited participant restraint during data collection

(Sharma, Agarwal, Sharma, & Dhuria, 2013). Participants wear reflective markers, placed on anatomical landmarks, which reflect (passive) or emit (active) light. Multiple cameras are aimed at a pre-identified area (arena), in which a human, object and/or workstation is identified through use of identifiable markers. The cameras identify each marker's trajectory through the use of computer software. The researcher can then use the software to post process the marker data through identification and filtering. Figure 12 identifies the four motion capture techniques previously discussed. Two types of optical marker systems are most common; active and passive. SELSPOT, OPTOTRACK and COSTEL software utilizes active markers in order to capture and analyze motion. Active motion capturing involves the use of light emitting markers, typically light emitting diodes (LEDs), which emit a signal to a camera. The camera then sends information to a computer where the marker's coordinates can be analyzed (Figueroa, Leite, & Barros, 2003). In contrast, passive systems determine marker coordinates using reflective balls. Passive cameras are outfitted with infrared lights which emit light towards an arena (collection area) which is reflected by the markers and picked back up by the cameras. The use of markers during motion tracking can be affected by placement, occlusion, clothing, and skin. Each of the previously mentioned effects can result in decreased reliability of kinematic measurements during optical motion analysis.

Originally developed as a biomechanical analysis tool, motion capture has become an important source of motion data for military, cinema, gaming, medical and educational purposes (Sharma et al, 2013). Motion capture usage in the military is typically involved in identifying issues with dimensions of fighter pilot cock pits, head movements during flight, and vehicle dimensions (Furniss, 1999). Motion capture is

commonly used during the production of video games and movies, such as Lord of the Rings, The Polar Express and Planet of the Apes (Lyttelton, 2014). The medical field uses motion capture to identify issues with activities of daily living, specifically human gait (Aminian & Najafi, 2004). Lastly, motion capture will be used in this study for educational purposes related to industrial and manufacturing work.

Motion capture has been used to determine head and torso movement during visual tasks in the workplace (Kim, Reed, & Martin, 2010). Chaffin and Faraway (2000) incorporated motion capture using the Human Motion Simulation Lab (HUMOSIM) to identify the effects of stature, age and gender on reach motion postures. Markers were placed on the wrist, elbow, shoulder and trunk in order to track motion during reaching tasks. Following up on the study by Kim, Reed and Martin (2010), Reed, Parkinson, and Klinkenberger (2003) assessed the validity of kinematically generated reach envelopes.

Research specific to power tool usage has examined operator whole-body posture as well as hand-arm and tool displacement. Kihlberg, Kjellberg and Lindbeck (1995) used a SELSPOT motion analysis system to determine hand-arm motion during pneumatic power tool use. Markers were placed on anatomical landmarks on the wrist, elbow and shoulder to determine motion during pneumatic tool securing. From this work, Kihlberg, Kjellberg and Lindbeck (1995) used motion capture technology to determine acceptability limits based on handle displacement. Furthermore, Lin, Radwin and Richard (2003b) compared their single-degree-of-freedom mechanical model, which attempts to predict power tool handle kinematics, to the OptoTrack motion analysis system. The OptoTrack system recorded the tool motion in three dimensions (X, Y, Z), and was found to positively correlate with the single-degree-of-freedom model ($R = 0.98$).

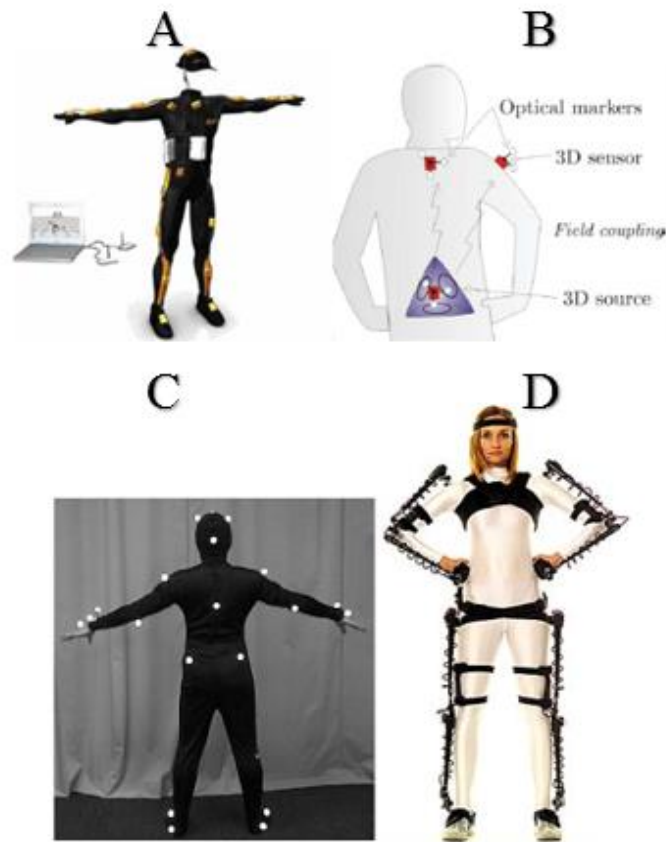

Figure 12: A) Inertial motion capture suit (Cloete & Scheffer, 2008), (B) Magnetic sensors (Roetenberg, 2006), (C) Optical motion capture suit (Kurihara, Hoshino, Yamane, & Nakamura, 2002), and (D) Mechanical motion capture suit (META Motion, 2014)

2.7 SUBJECTIVE RATINGS

In an attempt to understand how an individual subjectively perceives a stimulus, Borg (1982) developed a Category-Ratio Scale. The scale allows an individual to assign a number (ratio-scaling) to the given stimuli that is presented to them. The number chosen identifies the individuals subjective perceived perception associated with the given stimuli (Borg, 1990). Ratio-scaling methods use mathematical calculations to perform and compare physical and physiological measurements. However, there is no direct “level” of inter-individual comparisons. For example, a participant may rate a 10 kg mass

as a “5” and a 20 kg mass as a “10”. Another participant may provide ratings of “2” and “4”, respectively, with the same mass. However, each participant may not perceive the weights heavier or lighter than their counterparts (Borg, 1982). When evaluating effort or exertion levels, Borg developed a positive linearity scale that increases in value with exercise intensity and heart rate (HR). In 1990, Borg found ratings of perceived exertion (RPE) to be one of the most informative single indicators of degree of physical strain and can be supported in conjunction with physiological measurements (Borg & Borg, 2001).

As research has evolved, a slight variation to the RPE scale has been developed—the category ratio (CR) scale. CR scales improve RPE scales through use of verbal anchors. Predefined sets of verbal anchors are associated with values on the ratio scale, allowing the individuals to associate applied effort to a set value (Borg, 1982). For example, an individual raising his or her own arm with no resistance would express nothing at all on Borg’s CR-10 scale (Figure 13). When the same individual raises his or her arm with a 40 kg mass in their hand, a verbal anchor “Extremely Strong” could be identified. A strong exertion would equate to a value of 10. However, certain circumstances may result in a person’s perception of greater intensity due to pre-existing aches and pains, resulting in the ‘absolute’ maximum being higher than a value of 10; thus avoiding a ceiling effect (Borg & Borg, 2002). Therefore, development of category scales allows for direct inter-individual comparisons because the individual responds to a stimulus based on specified cues rather than a number (Borg, 1982).

Borg's CR-10 scale

| | | |
|------------|-------------------------|--------------------------|
| 0 | Nothing at all | |
| 0.5 | Extremely weak | (just noticeable) |
| 1 | Very weak | |
| 2 | Weak | (light) |
| 3 | Moderate | |
| 4 | | |
| 5 | Strong | (heavy) |
| 6 | | |
| 7 | Very strong | |
| 8 | | |
| 9 | | |
| 10 | Extremely strong | (almost max) |
| | ● Maximal | |

Figure 13: Borg's Category-Ratio 10-point scale (Borg & Borg 2002)

2.8 RATINGS OF PERCEIVED EXERTION USING POWER TOOLS

Researchers have used subjective ratings of perceived exertion when studying power tools in order to determine acceptable handle displacement caused by torque reactions (Kihlberg et al., 1995; Freivalds & Eklund, 1993; Lin & McGorry, 2009), ground reaction forces (Kihlberg et al., 1994), as well as determining acceptable limits for power tool usage (Kihlberg et al., 1995; Oh & Radwin, 1998). Kihlberg, Kjellberg, Lindbeck (1993, 1994 and 1995) conducted a series of studies determining the influence of joint type and acceptability of right angled power tools. The initial study (1993) consisted of three different power tools: two slow reacting air shut-offs, and a third with a quick reacting mechanical clutch. The participant's subjective ratings while using power tools were shown to have a mean positive correlation of 0.87 with tool handle displacement. Furthermore, Lindqvist (1993) stated that in order to limit discomfort, the control techniques used when tightening a fastener must change. Kihlberg, Lindbeck and

Kjellberg (1993) studied subjective ratings for three-shut-off mechanisms of right angle power tools with equal spindle torque speeds. The lowest ratings were identified with the fast shut-off mechanism, which also resulted in the least tool handle displacement. The delayed shut-off mechanism resulted in the greatest handle displacement and greatest subjective operator ratings. Kihlberg, Kjellberg and Lindbeck (1995) created pneumatic power tool acceptability limits based on subjective ratings. All participants indicated that they would accept jobs rated a “2” on a CR-20 scale, and no participant would accept a task that rated “9” or above on the same CR-20. Ninety percent of participants accepted a maximum handle displacement of 3 cm, and handle displacements of 4 and 6 cm were accepted by 50% of participants, respectively.

Chapter 3: METHODS

3.1 PARTICIPANTS

Thirty-six healthy participants (N=18 M, N=18 F) between the ages of 22-64 years (Table 1), who had no right angle power tool experience and no injuries to the arms or trunk which limited them from participating in work or activities of daily living, were recruited from the general population. Each participant filled out a Nordic musculoskeletal disorder questionnaire (Wiehagen & Turin, 2004), in order to determine musculoskeletal injuries that may result in participant exclusion (APPENDIX D). Participants were also asked if they are allergic to any adhesives or tape. The participants were randomly assigned to one of two experimental groups: 1) Hard joint (N=9 f, N=9 m) and 2) Soft joint (N=9 f, N=9 m).

Table 1: Complete participant age, height and weight data.

| Age Group | | Age (years) | Height (cm) | Mass (kg) |
|------------------|----------------|--------------------|--------------------|------------------|
| 18-29 | <i>Average</i> | 25.42 | 173.2 | 72.1 |
| | <i>Max</i> | 29 | 185.5 | 90.5 |
| | <i>Min</i> | 22 | 160.0 | 55.3 |
| | <i>STD</i> | 2.19 | 8.3 | 10.0 |
| 30-45 | <i>Average</i> | 33.33 | 170.9 | 81.8 |
| | <i>Max</i> | 42 | 189.0 | 114.5 |
| | <i>Min</i> | 30 | 156.0 | 64.2 |
| | <i>STD</i> | 3.34 | 11.5 | 15.6 |
| 45+ | <i>Average</i> | 52.67 | 175.0 | 88.7 |
| | <i>Max</i> | 64 | 198.0 | 125.4 |
| | <i>Min</i> | 48 | 157.5 | 61.7 |
| | <i>STD</i> | 3.96 | 13.3 | 17.6 |
| Total | <i>Average</i> | 37.14 | 173.0 | 80.8 |
| | <i>Max</i> | 64 | 198.0 | 125.4 |
| | <i>Min</i> | 22 | 156.0 | 55.3 |
| | <i>STD</i> | 12.03 | 11.2 | 16.2 |

3.2 INSTRUMENTATION AND DATA ACQUISITION

The kinematics of the trunk, head, upper and lower extremities were captured using a passive marker system (Motion Analysis Corporation, Santa Rosa, California) and sampled at a rate of 60 Hz. The placement of the fifty-two passive markers is outlined in APPENDIX E. Additionally, handle forces were collected using a simulated handle outfitted with a 3D linear sensor which collected forces in the up/down (Fx), push/pull (Fy) and in/out (Fz) directions (Figure 15). The handle forces were collected at a rate of 2100Hz, digitally converted and then low-passed Butterworth filtered (2nd order with cutoff = 15 Hz). Two right angle power tools were used to complete joint fastenings (Atlas Copco, 2014). Additionally, joint simulators for hard (30⁰) and soft (540⁰) fastening were instrumented to a custom made device allowing for adjustment of location and orientation. Lastly, a 10-point Borg scale (Figure 14) was implemented in order to collect participant's perceived exertion and discomfort (Borg, 1990; Borg, 1982).

| | |
|-----|--------------------|
| 0 | None |
| 0.5 | Very, very light |
| 1 | Very light |
| 2 | Light |
| 3 | Moderate |
| 4 | Not very intense |
| 5 | Intense |
| 6 | |
| 7 | Very intense |
| 8 | |
| 9 | Very, very intense |
| 10 | Maximum |

Figure 14: Modified Borg 10-point scale used to determine participant exertion levels (Borg, 1982)

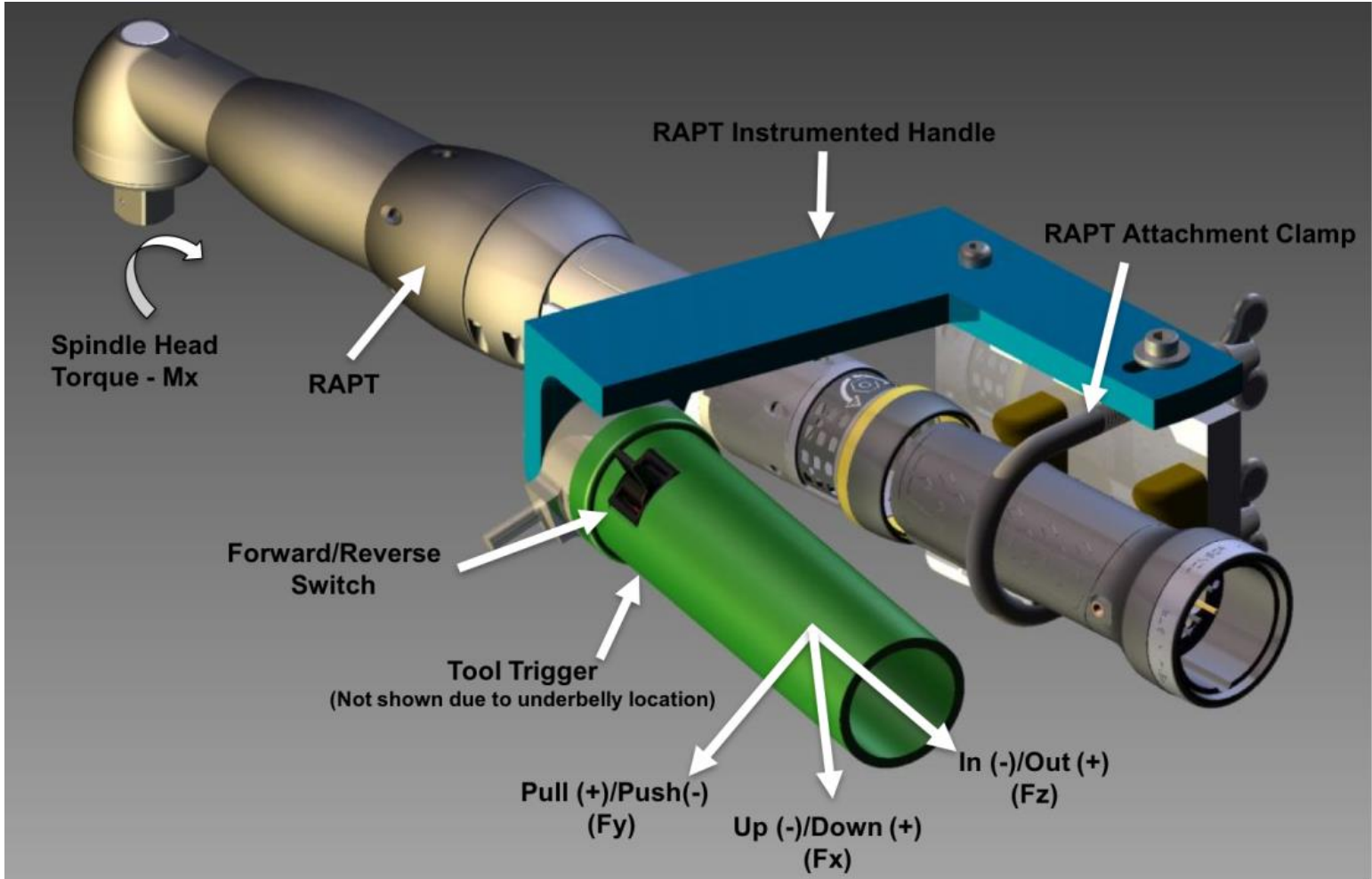

Figure 15: Instrumented handle 3D linear sensor directions

3.3 EXPERIMENTAL PROCEDURE AND PROTOCOL

Upon entering the lab, each participant's age, height, mass and handedness were collected. Participants then performed a familiarization period, in which they were given a script (**APPENDIX A**) describing the study and participant involvement, as well as a fifteen-minute period in which they were allowed to perform any of the tightening conditions they would perform during data collection. Participants were then outfitted with the fifty-two passive motion capture markers (**APPENDIX E**). Once the participant was fully outfitted with the marker set, a T-Pose trial, consisting of the participant standing feet shoulder width apart with arms raised to the side, was collected in order to create a template for the individual. In addition to the T-Pose trial, a range of motion trial was collected. The range of motion trial consisted of: elbow flexion/extension, shoulder flexion/extension and abduction/adduction, trunk rotation and flexion/extension, trunk lateral bend, neck flexion/extension/rotation and squats.

Following the ROM trial, participants commenced the fastening protocol. The fastening protocol consisted of a five minute bout of joint fastening condition with a three minute rest break between each condition where a subjective rating was provided. A single set of right angle power tool fastening conditions consisted of 5 individual right angle power tool fastening secures within a 60 second period, as defined by Potvin, Agnew, and Ver Woert (2004). Each participant completed thirty-six total conditions consisting of a combination of the variables shown in Figure 16 (4 postures X 3 target torques X 3 tightening strategies) on their randomly selected joint hardness. Participants completed eighteen conditions on the first day and eighteen conditions on their second day. A minimum of forty-eight hours was provided between each collection day.

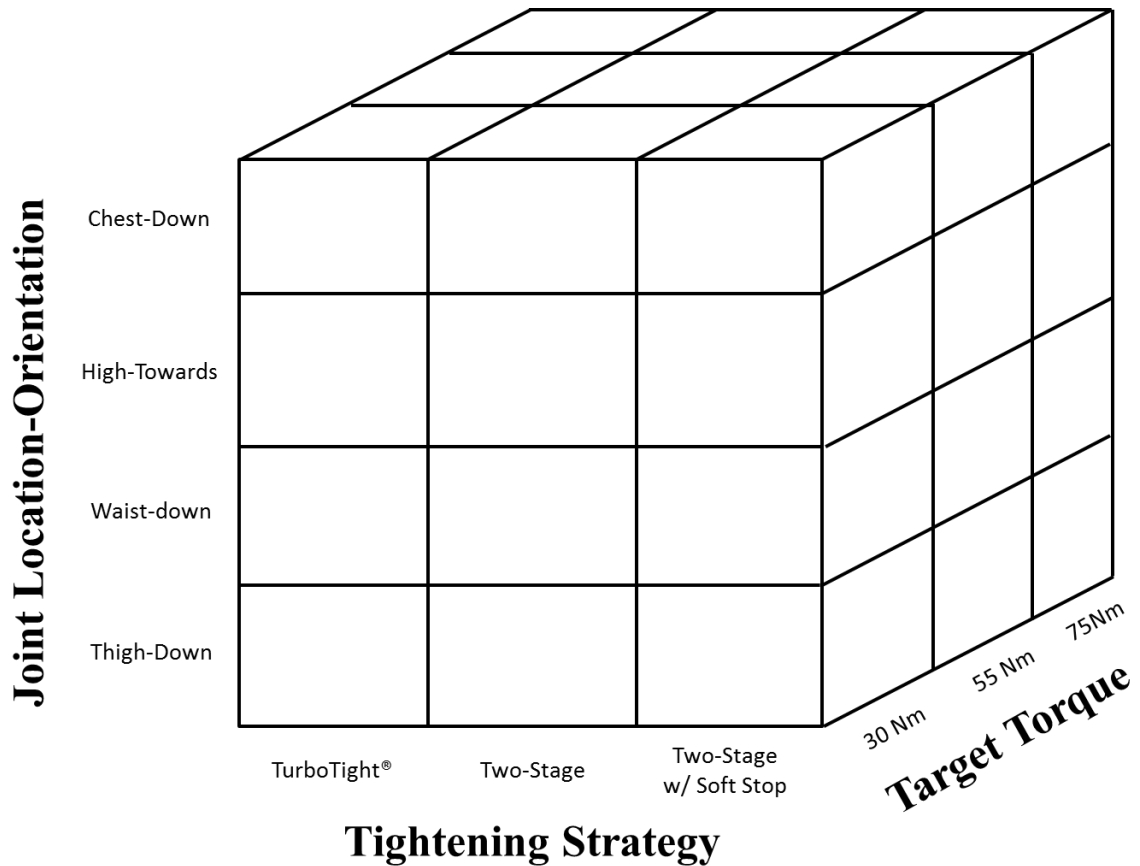

Figure 16: Independent variable matrix

Joint location-orientations (Figure 17) were chosen in order to produce real-world postures in the lab setting. Vertical distance (V) were measured from the ground up, horizontal distances (H) were measured from the middle of the ankle and lateral distance (L) were measured from the midpoint of the ankles with left being negative and right being positive. The joint location-orientations were located using the following measurements and direction: 1) H:60 cm, V:117 cm, L:10 cm and downward shot direction, 2) H:38cm, V:75cm, L:52 cm and downward shot direction, 3) H:29 cm, V:153 cm, L:36 cm and towards shot direction, 4) H:53 cm, V:103 cm, L:35 cm and downward shot direction.

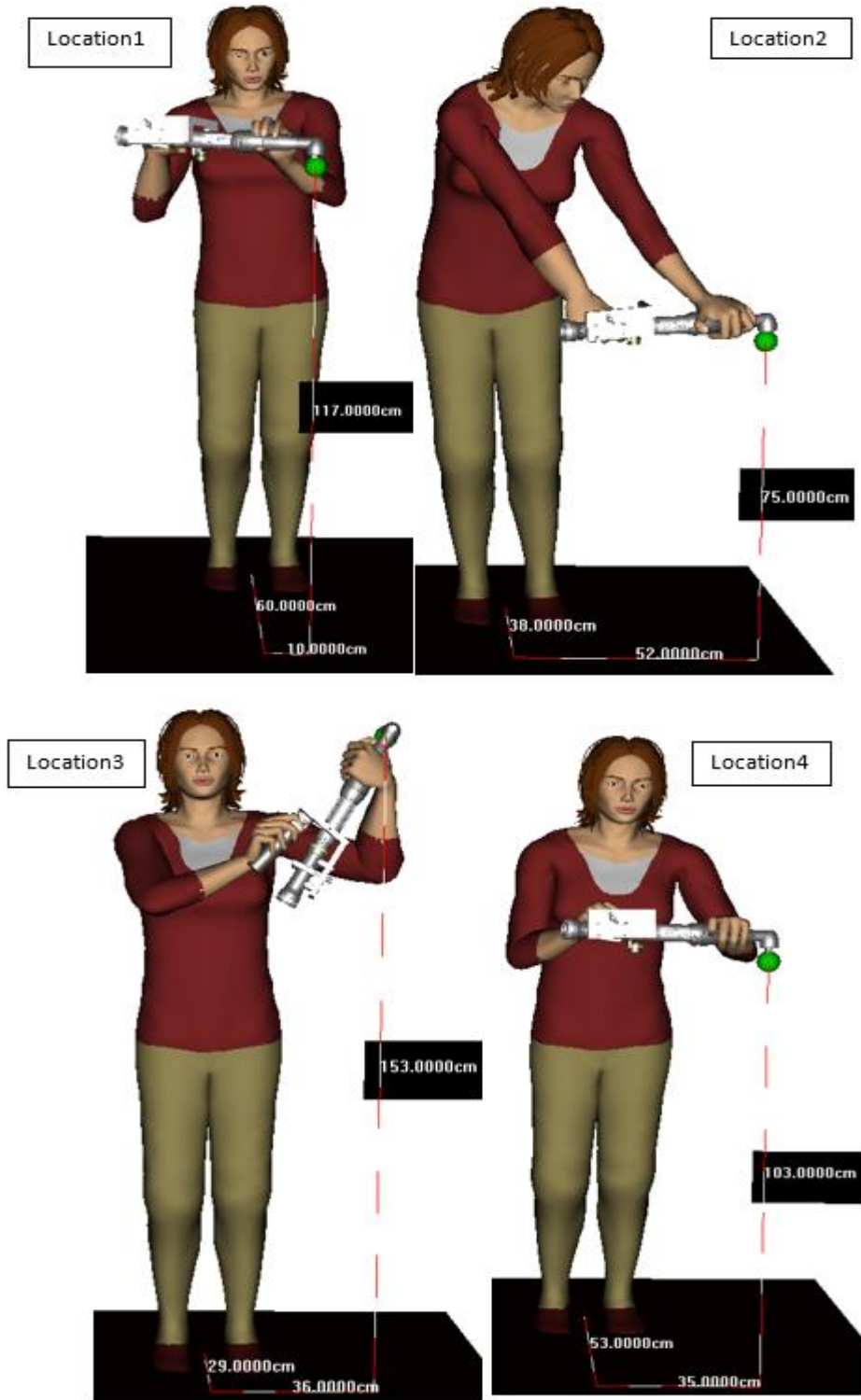

Figure 17: Locations of the four joint location-orientations Location 1: Chestdown, Location 2: Thighdown, Location 3: Hightowards, Location 4: Waistdown

3.4 DATA ANALYSIS

Handle force data were collected using a 3D linear sensor at a sampling rate of 2100 Hz. The handle force data were filtered using LabView software. The force impulse was determined through the multiplication of the force experienced at a given time, and then summed for a total impulse measurement. Following the examination of the data post collection, analog data were missing for 3 of the participants on day 1 (18 conditions). The expectation maximization technique was used to manage the missing data through the missing value analysis function in SPSS (Schafer & Olsen, 1998)

Motion Capture data were collected at a sampling rate of 60 Hz using Motion Analysis Motion Capture system (Motion Analysis Corporation, Santa Rosa, California). Markers on the right arm were used to determine the relative angle of shoulder and elbow, where the arm was identified by the acromion process, bicep, lateral elbow and distal end of humerus markers, and forearm identified by the lateral elbow, distal end of humerus, forearm, radial and ulnar markers. Shoulder angular displacement was calculated using a joint coordinate system and the Software for Interactive Musculoskeletal Modelling (SIMM) (Musculographics Inc., Santa Rosa, California). The cardan sequence of rotations per Cole, Nigg, Ronsky and Yeadon (1993) was used identified as: X (medio-lateral), Y (anterior/posterior), Z (up/down). All joint angles were identified at torque initiation and 100 ms post target torque in order to determine angular displacement. Subjective ratings of perceived exertion and discomfort were collected following each 5 minute trial using a Borg CR-10 scale (Borg, 1982).

3.5 STATISTICAL ANALYSIS

A 3 way 3x3x4 analysis of variance (ANOVA) with repeated measures was performed, for hard and soft joints ,in order to determine the influence of each of the 3 independent variables: target torque (30 Nm, 55 Nm, 75 Nm), tightening strategy (TT, TS, TSS), and posture (hightowards, chestdown, waistdown, thighdown). The significance level for each ANOVA was set at $p < 0.05$. Significant main and interaction effects were compared using Tukey's HSD post hoc test. Greenhouse-Geiser test of sphericity ($p < 0.05$) and partial η^2 was used for effect size within each interaction. The dependent variables in the study were handle force impulse (Figure 18), shoulder displacement, elbow displacement and subjective ratings of perceived exertion and discomfort.

Chapter 4: RESULTS

4.1 HANDLE DATA

The handle data consisted of forces in 3 linear directions, Fx (Down = -, Up = ++), Fy (Push = - , Pull = +), Fz (In = --, Out = +). Which were measured and impulse calculated from torque initiation to tool shut-off. From this point forward, the term, force, is referring to force impulse as collected during this study.

4.1.1 IMPULSE

4.1.1.1 Up/Down (Fx)

A 3-way interaction of Posture x TT x Strategy ($F = 4.53$, $p = 0.002$.) was found for the handle force impulse in the up/down direction (Fx) (Figure 19). Post hoc testing showed fastening in the chestdown posture, 30 Nm target torque using TT produced 63.6% less

force in Fx than TS and, 74% less force than TSS and TS produced 29.5% less force than TSS.

Additionally, fastening a 55 Nm target torque using TT produced 50.6% less force than TS. Lastly, fastening a 75 Nm target torque using TT produced 54.8% less force than TS, 39.5% less force than TSS and, TS produced 25.3% less force than TSS.

Operating in the high towards posture, with a 30 Nm target torque using TT produced 91.7% less force in Fx than TS and, 96% less than TSS. Fastening 55 Nm target torque using TT produced 82.9% less force than TS and, 86.3% less force than TSS. Finally, using TT with 75 Nm target torque produced 82.3% less force than TS and, 76.9% less than TSS.

When in the thighdown posture fastening 30 Nm target torque using TT produced 70.9% less force in Fx than TS and 83.2% less force than TSS. While TS produced 42.4% less force than TSS. Fastening 55 Nm target torque using TT produced 63.4% less force in Fx than TS and, 68.7% less force than TSS. Fastening 75 Nm target torque fastening in thighdown posture using TT produced 69% less force than TS and, 67% less than TSS.

Operators performing in the waistdown posture, fastening 30 Nm target torque using TT produced 64.5% less force in Fx than TS and, 77.1% less force than TSS. While fastening 55 Nm target torque using TT produced 64.4% less force than TS and, 66.3% less force than TSS. Lastly, fastening 75 Nm target torque using TT produced 62.8% less force than TS and, 64.2% less force than TSS.

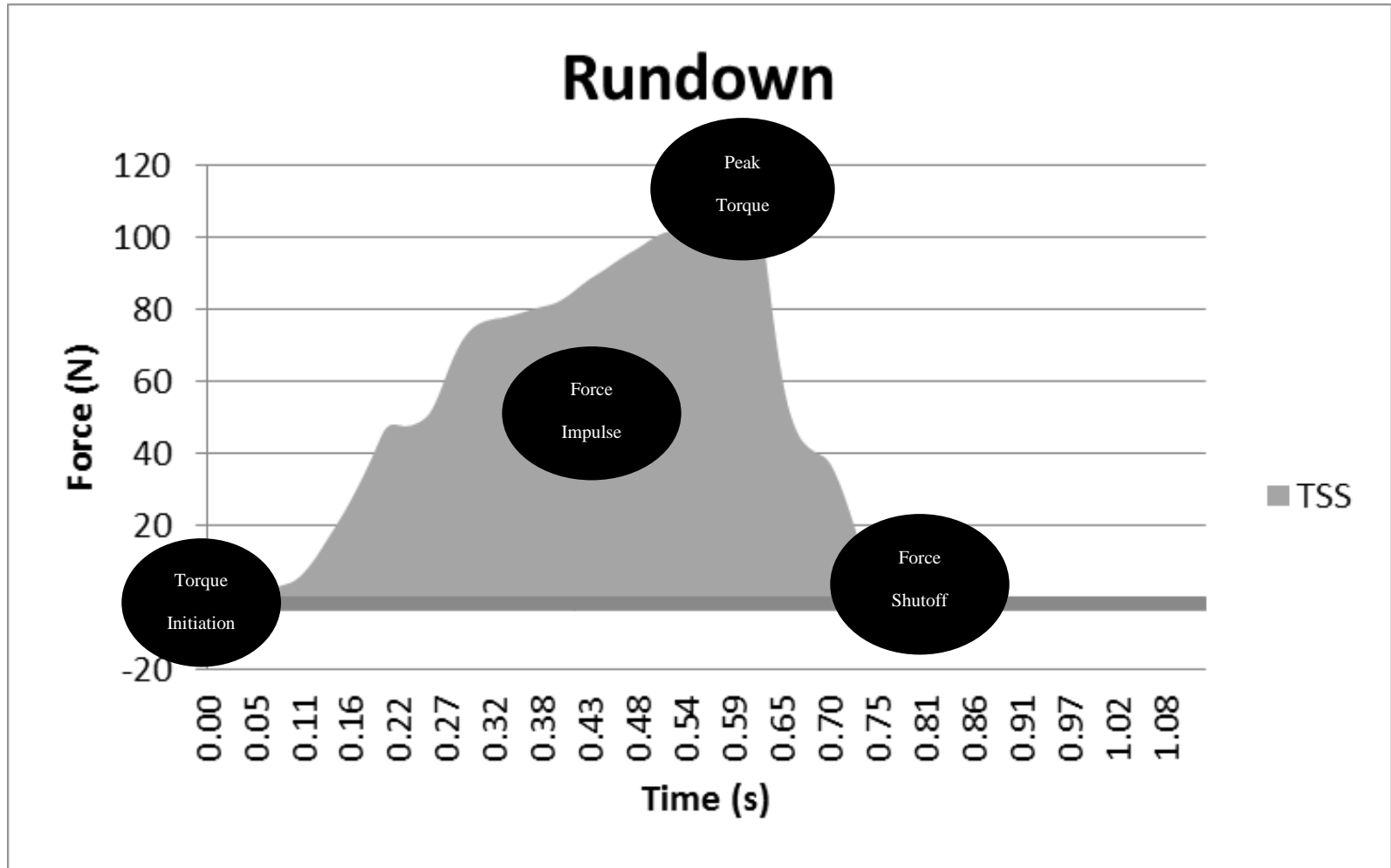

Figure 18: TSS tightening strategy identification of torque initiation, peak torque, tool shut-off and impulse.

A 3-way interaction of TT x Strategy x Hardness ($F = 15$, $p=0.001$.) was found for the handle force impulse in the up/down (Fx) direction (Figure 20). Post hoc testing showed participants fastening on a hard joint with 30 Nm using TT produced 73.3% less force in Fx than TS and, 71.2% less force than TSS. While fastening 55 Nm using TT resulted in 62.8% less force production than TS and, 62.9% less force than TSS. Finally, when fastening a 75 Nm joint with TT, participants used 75.4% less force in Fx than when using TS and, 74.3% less force in Fx using TSS when fastening a hard joint. Participants fastening a soft joint while fastening 30 Nm using TT produced 59.1% less force in Fx than TS and, 79.3% less force than TSS. Additionally, TS produced 49.4% less force in Fx than TSS.

Participants fastening 55 Nm using TT produced 56.2% less force than TS and, 58.3% less force than TSS. Finally, participants fastening 75 Nm using TT produced 53.5% less force than TS and, 52.3% less force than TSS when fastening on a soft joint.

A 3-way interaction of Posture x Strategy x Hardness ($F=31.2$, $p=0.0001$) was found for the handle force impulse in Fx (Figure 21). Post hoc testing showed participants fastening a hard joint in the chestdown posture using TT produced 67.4% less force in Fx than TS when fastening. Participants fastening in the thighdown posture using TT produced 78.7% less force than TS and, 77.3% less force than TSS. Lastly, fastening on a hard joint in the waistdown posture using TT produced 73.4% less force than TS and, 73.1% less force in Fx than TSS. Operators fastening a soft joint in the chestdown posture using TT produced 50.2% less force in Fx than TS and, 51.5% less force than TSS. In the hightowards posture, operators using TT produced 12.1% less force than TS and, 82% less force than TSS. Fastening in the thighdown posture using TT

produced 63.3% less force than TS and, 72% less force than TSS. While, TS produced 23.6% less force in Fx than TSS. Lastly, fastening in the waistdown posture using TT produced 60% less force in Fx than TS, 68.3% less force than TSS and, TS produced 20.6% less force than TSS on a soft joint.

4.1.1.2 Push/Pull (Fy)

A 3-way interaction of TT x Strategy x Hardness ($F=56.3$, $p=0.001$.) was found for the handle force impulse in the push/pull (Fy) direction (Figure 22). Post hoc testing showed participants fastening 30 Nm using TT produced 94.5% less force than TS and, 94.6% less force than TSS in Fy when fastening on a hard joint.

Additionally, fastening a 55 Nm target torque using TT produced 87.4% less force than TS and, 87.1% less force than TSS when fastening on a hard joint. Furthermore, fastening a 75 Nm target torque using TT produced 92.3% less force than TS and, 91.9% less force than TSS when fastening on a hard joint. Participants fastening a 30 Nm soft joint using TT produced 78% less force than TS, 89.8% less force than TSS and, TS produced 53.6% less force in Fy than TSS. While fastening a 55 Nm soft joint participants using TT produced 74.5% less force than TS, 77.1% less force than TSS and, TS produced 10% less force in Fy than TSS. Lastly, fastening a 75 Nm soft joint, participants using TT produced 67.1% less force than TS and, 39.3% less force in Fy than TSS.

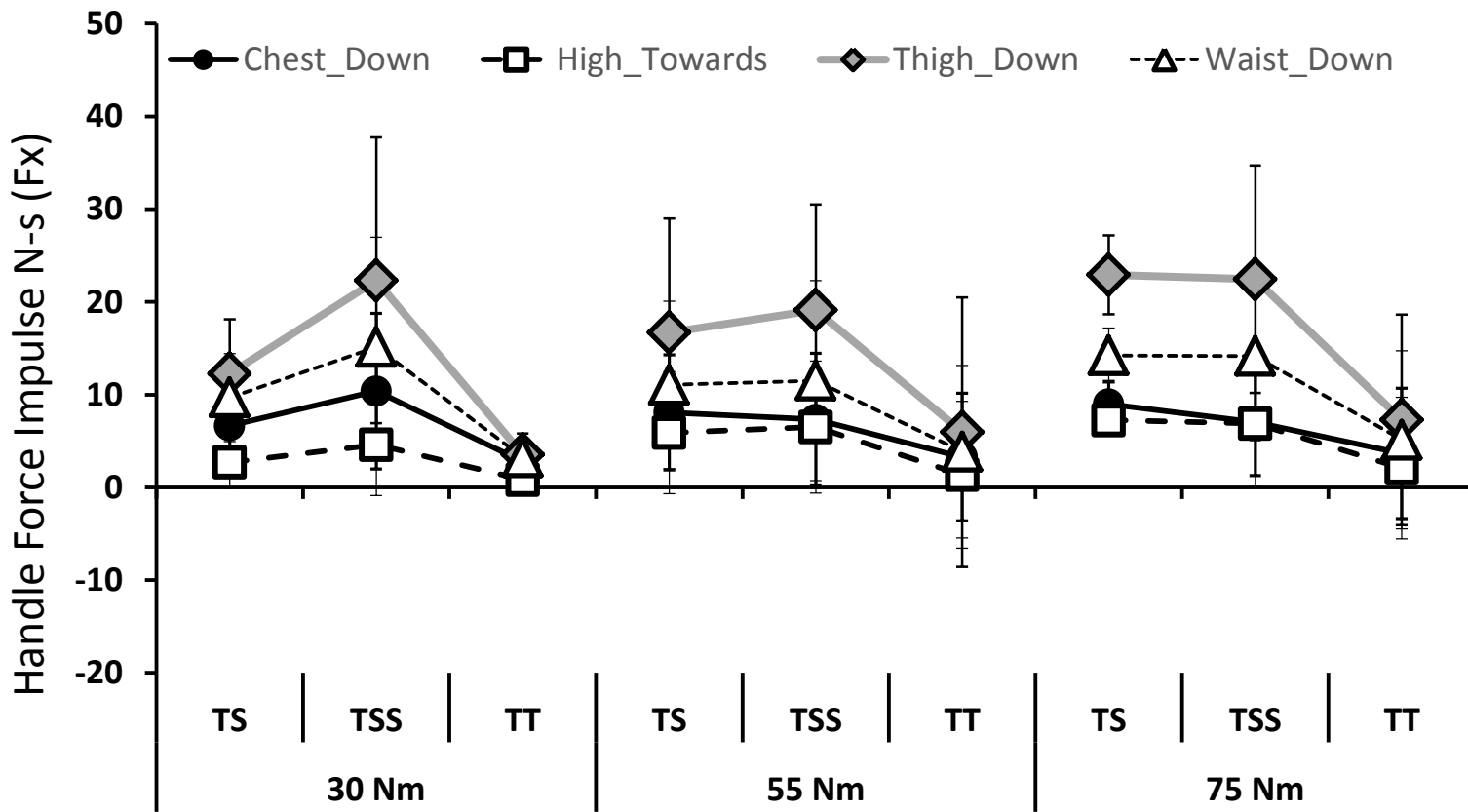

Figure 19: Average force impulse (Fx) while operating TS, TSS and TT comparing target torque, and posture. Showing significant reduction in force impulse while operating TT..

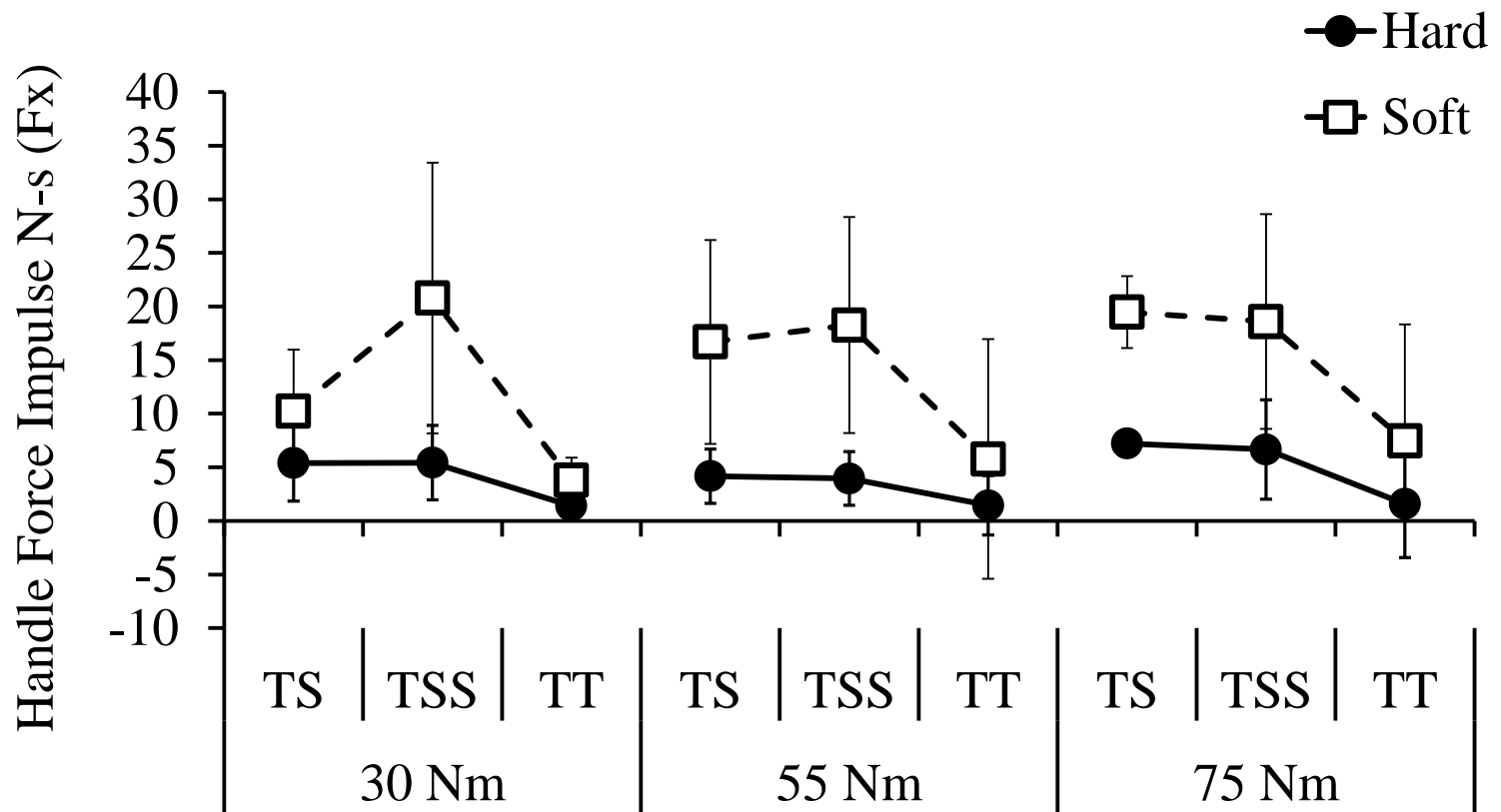

Figure 20: Average force impulse F_x , comparing the three tightening strategies between three increasing target torques as well as hard and soft joints. Significant reduction is found when operating hard joints as well as soft joints.

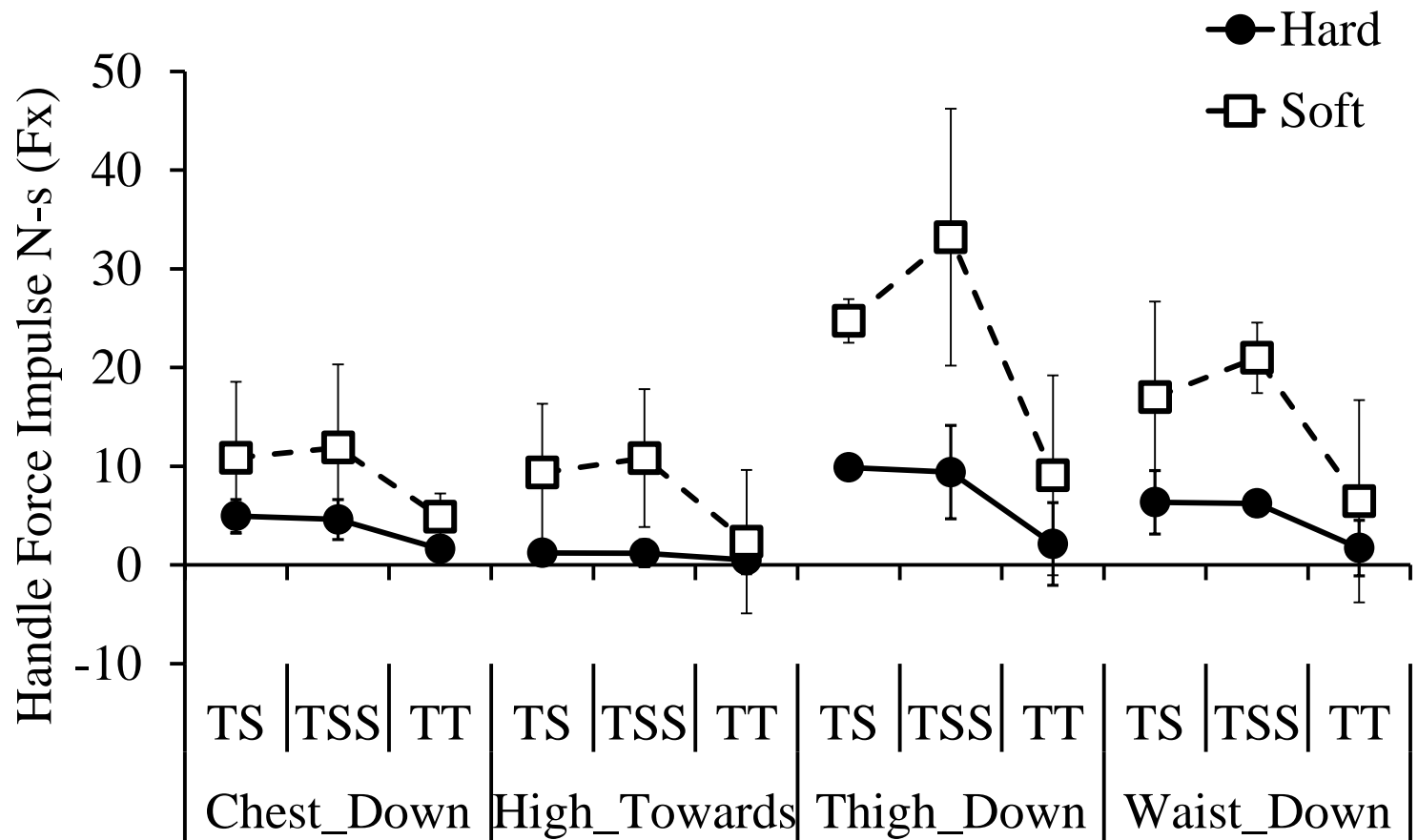

Figure 21: Average force impulse F_x , comparing the three tightening strategies between posture and joint hardness. Soft and hard joints showed a reduction in force impulse while using TT compared to TS and TSS.

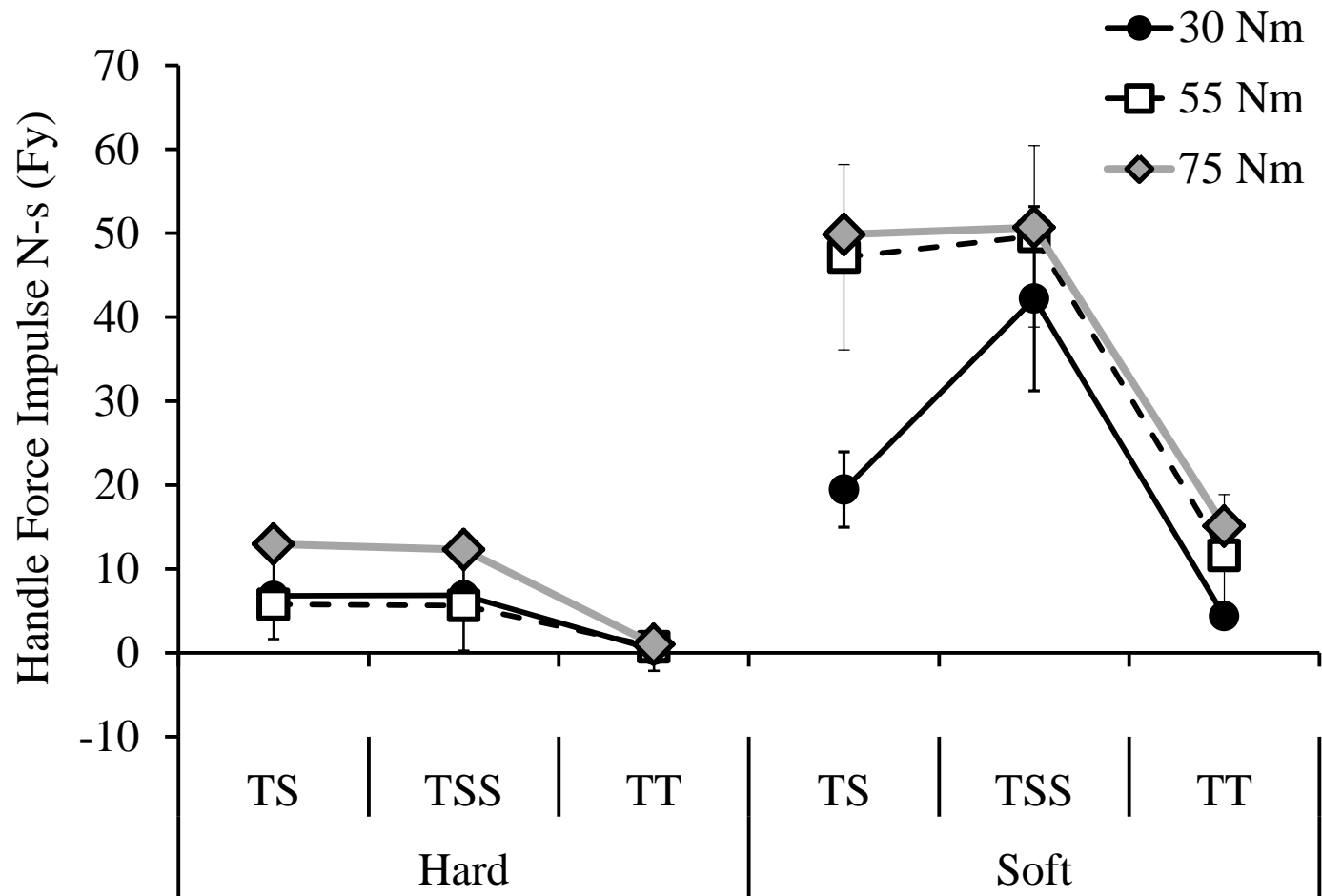

Figure 22: Average Force F_y , comparing tightening strategy at the three target torques withing hard and soft joint operation. TT resulted in the least handle force impulse at each target torque regardless of joint hardness.

4.1.1.3 IN/OUT Fz

Post hoc testing resulted in no significant interactions for Fz.

4.2 JOINT ANGLES

Participant right shoulder (adduction = + abduction = -, flexion = +, extension = -, internal rotation = +, external rotation = -) and elbow (flexion = +, extension = -) angular displacement were captured and displacement measured between torque initiation and 100 ms post target torque.

4.2.1 ARM ADDUCTION

A 4-way interaction of Hardness x Posture x Strategy x TargetTorque ($F= 2.671$, $p= 0.033$) was found for arm adduction (Figure 23). Post hoc testing showed participants fastening on a hard joint in the chestdown posture fastening 30 Nm target torque using TT resulted in 91.7% less displacement than TS and, 85.9% less displacement than TSS. Fastening a 55 Nm target torque using TT resulted in 97.8% less displacement than TS and, 96.3% less than TSS.

When in the thighdown posture, participants fastening a 30 Nm target torque on a hard joint using TT resulted in 94.8% less displacement than TS and, 95.9% less than TSS. Additionally, fastening 55 Nm target torque using TT resulted in 81.6% less displacement than TS and, 81.7% less than TSS.

Participants in the waistdown posture, fastening a hard joint and 30 Nm target torque using TT resulted in 97.6% less displacement than TS and 97.1% less than TSS. When fastening a 55 Nm target torque using TT resulted in 85.7% less displacement than TS and, 83.3% less than TSS.

Participants fastening a soft joint in the chestdown posture fastening a 30 Nm target torque using TSS resulted in 22% less displacement compared to TS and 25.2% less than TT. In addition, using TS resulted in 4% less displacement than TT. Fastening a 55 Nm target torque using TS resulted in 3% less displacement compared to TT and, TSS resulted in 34% less displacement than TT. Target torque of 75 Nm using TSS resulted in 11.1% less displacement than TS and, 26.3% less than TT. While using TS, results showed 17% less displacement than TT in the chestdown posture.

While in the hightoward posture on a hard joint fastening 55 Nm target torque using TSS resulted in 5% less displacement than TS and, 43.8% less than TT and TS resulted in 41.1% less than TT. Lastly, fastening a 75 Nm target torque using TT resulted in 23.8% less displacement than TSS.

Participants in the thighdown posture fastening 30 Nm target torque using TS resulted in 12.4% less displacement than TT. Additionally, fastening the RAPT with TSS resulted in 29.2% less displacement than TT. Fastening a 55 Nm target torque using TSS resulted in 15.5% less displacement than TS and, 1.5% less displacement than TT. Furthermore, using TT resulted in 14.3% less displacement than TS. Lastly, Fastening a 75 Nm target torque using TS resulted in 9.4% less displacement than TSS and, 26.3% less displacement than TT and, TSS resulted in 18.6% less displacement than TT.

Fastening on a soft joint in the waistdown posture with 30 Nm target torque using TSS resulted in 53.9% less displacement than TS and, 66.1% less displacement than TT. Additionally, TS resulted in 26.4% less displacement than TT. Fastening a 55 Nm target torque using TSS resulted in 14.1% less displacement than TS and, 30.7% less displacement than TT, TS resulted in 19.3% less displacement than TT. Lastly, 75 Nm

target torque using TSS resulted in 4% less displacement than TS and, 15% less displacement than TT and, TS resulted in 11.1% less displacement than TT.

4.2.2 ARM FLEXION

A 3-way interaction of Hardness x TargetTorque x Strategy ($F=3.595$, $p=0.022$) was found for arm flexion (Figure 24). Post hoc testing showed participants fastening on a hard joint with 30 Nm target torque using TT resulted in 88.2% less displacement than TS and, 87.8% less displacement than TSS. Participants fastening 30 Nm target torque on a soft joint using TSS resulted in 31.3% less displacement than TS and, 52.1% less displacement than TT and TS resulted in 30.3% less displacement than TT.

Participants fastening 55 Nm target torque on a hard joint resulted in 75.5% less displacement than TS and, 77.5% less displacement than TS.

Participants fastening on a hard joint using 75 Nm target torque resulted in 78.2% less displacement than TS and 79.6% less displacement than TSS.

A 3-way interaction of Hardness x Posture x TargetTorque ($F=3.066$, $p=0.045$) was found for arm flexion (Figure 25). Post hoc testing showed participants fastening on a hard joint in the chestdown posture using 30N target torque resulted in 60.4% less displacement than 75 Nm target torque. While fastening on a soft joint in the chestdown posture using 30 Nm target torque resulted in 68.9% less displacement than 75 Nm target torque; 55 Nm target torque resulted in 98% less displacement than 75 Nm target torque.

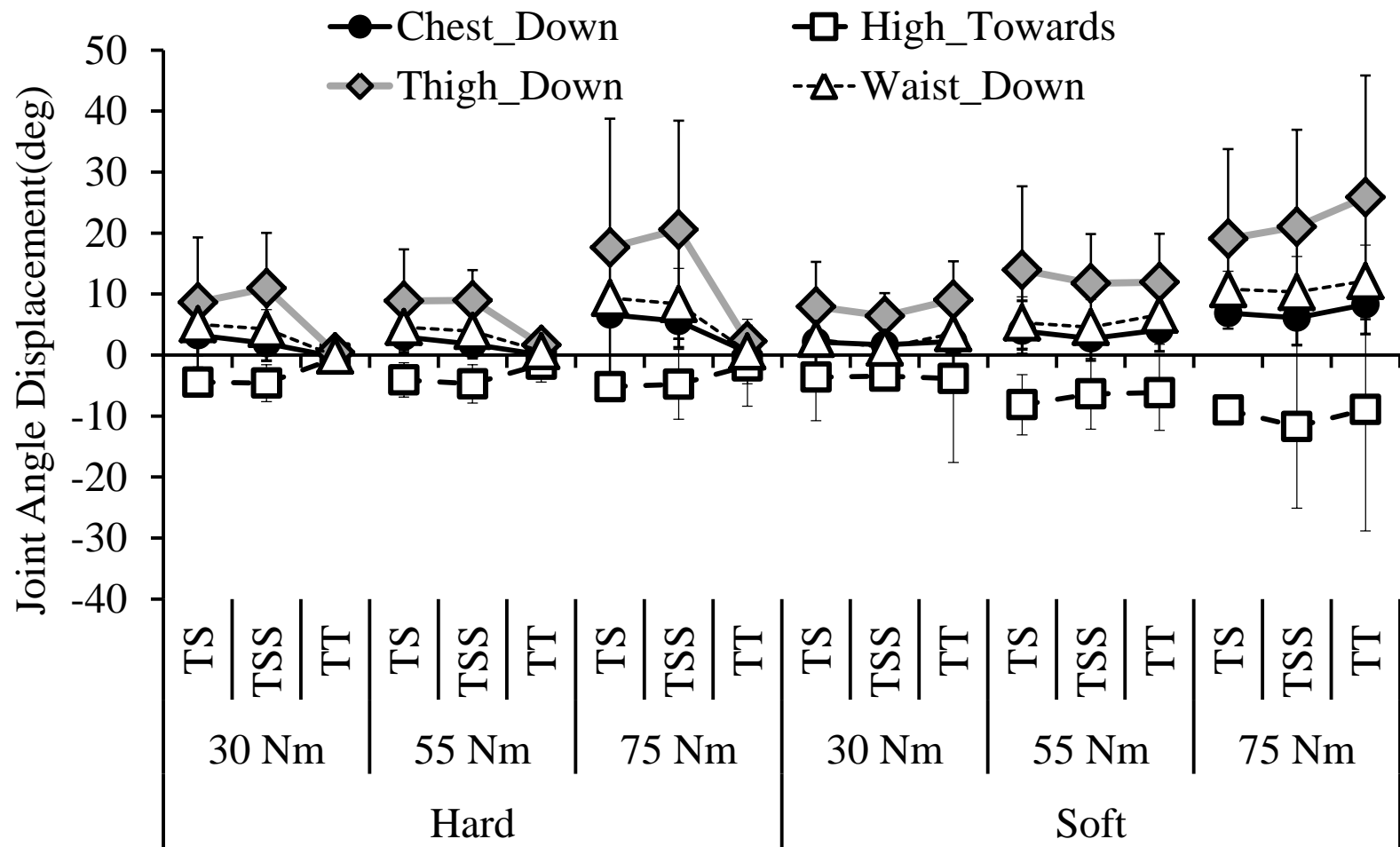

Figure 23: Average shoulder adduction angular displacement measured between torque initiation and 100 ms post target torque. TT results in the least displacement while operating on hard joints.

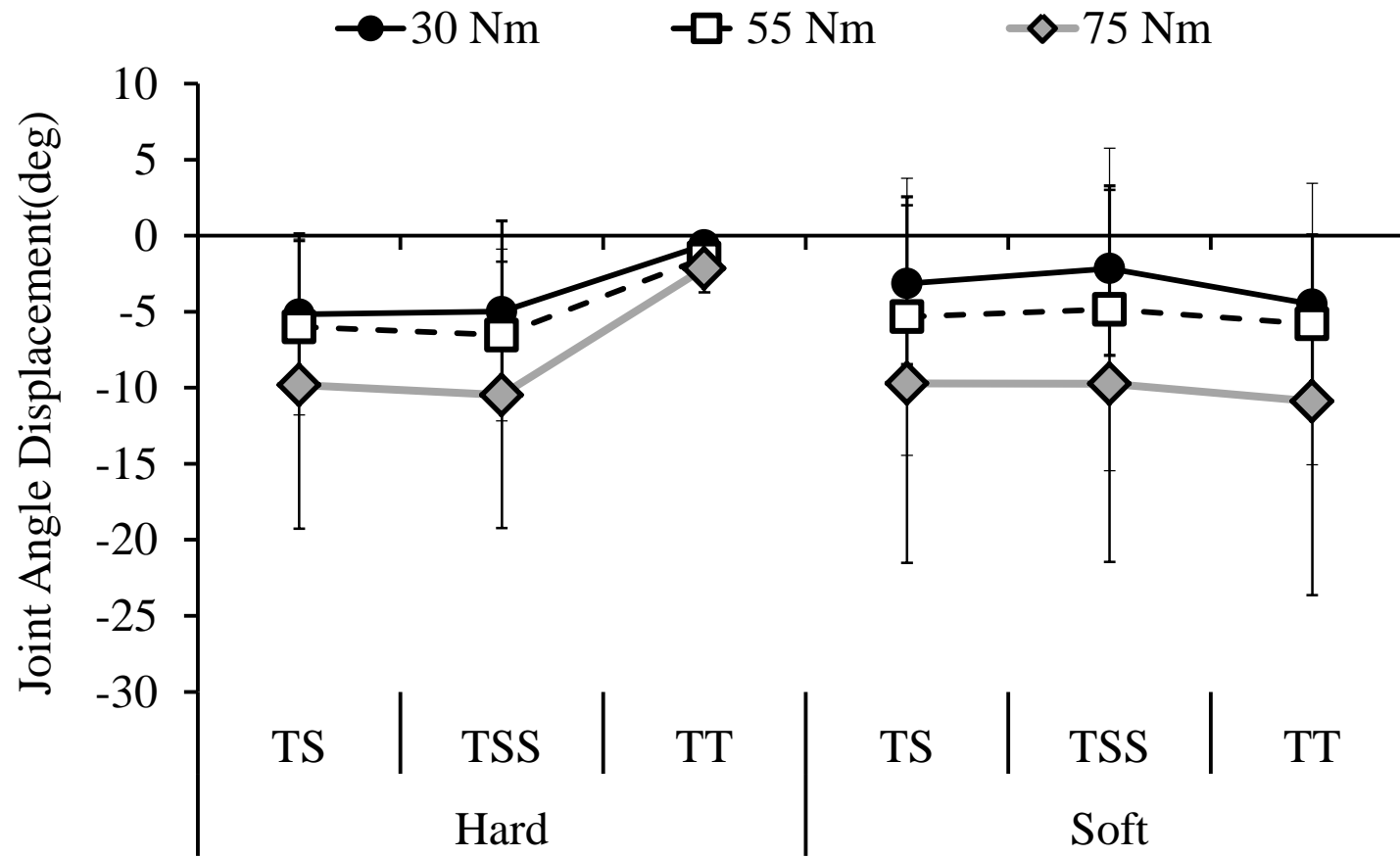

Figure 24: Average arm flexion angular displacement measured between torque initiation and 100 ms post target torque, comparing tightening strategies and target torques while fastening on hard and soft joints.

Participants in the hightoward posture fastening on a hard joint using 55 Nm target torque resulted in 62.1% less displacement than 75 Nm target torque. Additionally, fastening on a soft joint in the hightoward posture using 30 Nm target torque resulted in 70.1% less displacement than 55 Nm target torque and, 85.6% less displacement than 75 Nm target torque; 55 Nm target torque resulted in 51.9% less displacement than 75 Nm target torque.

Participants, fastening on a hard joint in the thighdown posture using 30 Nm target torque resulted in 24.4% less displacement than 55 Nm target torque and, 48.3% less displacement than 75 Nm target torque; 55 Nm target torque resulted in 31.6% less displacement than 75 Nm target torque. In the thighdown posture fastening on a soft joint using 30 Nm target torque resulted in 20.9% less displacement than 55 Nm target torque and, 58.5% less displacement than 75 Nm target torque; 55 Nm target torque resulted in 31.1% less displacement than 75 Nm target torque on a soft joint.

Lastly, fastening in the waistdown posture on a hard joint using 30 Nm target torque resulted in 43.7% less displacement than 75 Nm target torque and, 55 Nm target torque resulted in 35.4% less displacement than 75 Nm target torque. Fastening on a soft joint in the waistdown posture using 30 Nm target torque resulted in 20.9% less displacement than 55 Nm target torque and, 64.2% less displacement than 75 Nm target torque; 55 Nm target torque resulted in 54.7% less displacement than 75 Nm target torque.

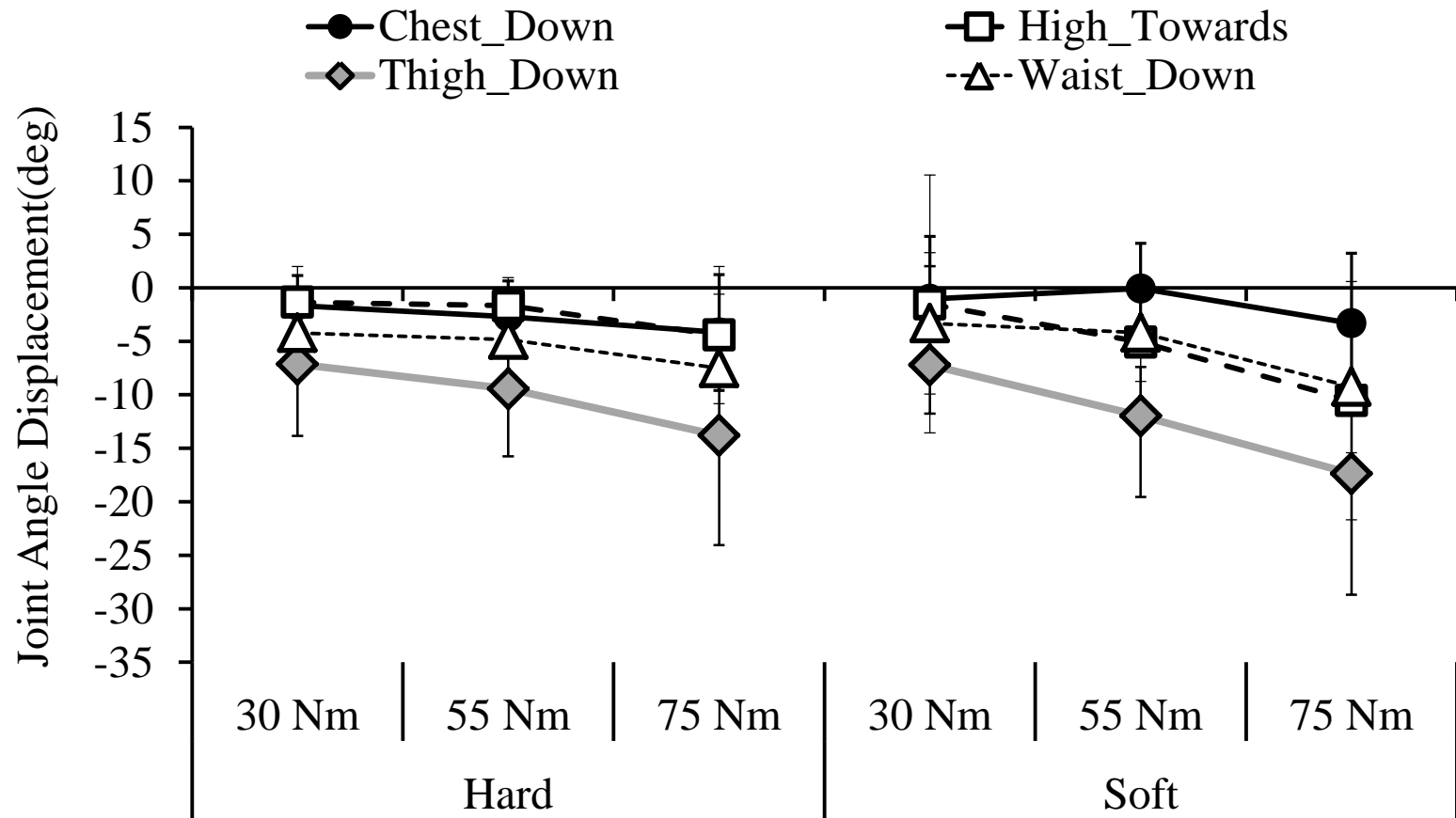

Figure 25: Average arm flexion angular displacement measured between torque initiation and 100 ms post target torque, comparing postures and tightening strategies while operating on hard and soft joints. Regardless of posture, greater displacement was found with increasing target torque. -

4.2.3 ARM ROTATION

A 3-way interaction of Hardness x Posture x Strategy ($F=3.323$, $p=0.026$) was found for arm rotation (Figure 26). Post hoc testing showed fastening on a hard joint in the chestdown posture using TT resulted in 74.6% less displacement than TS and, 73.5% less than TSS. Fastening the TT strategy on a hard joint in the thighdown posture, angular displacement was 80.3% less than TS and 84.5% less than TSS. Fastening on a hard joint in the waistdown posture using TT was 75.1% less than TS and 76.6% less than TSS; TS was 5.9 % less than TSS. Lastly, fastening on a soft joint in the chestdown posture using TT was 21.4% less than TSS.

A 3-way interaction of Posture x TargetTorque x Hardness ($F=2.906$, $p=0.029$) was found for arm rotation (Figure 27). Post hoc testing showed fastening on a hard joint in the chestdown posture using 75 Nm target torque resulted in 69.8% less angular displacement compared to 30 Nm and, 69.8% less than 55 Nm. Fastening in the HighTowards using 75 Nm 223.5% less than 55 Nm. Thighdown posture fastening 75 Nm resulted in 165.6% less displacement than 30 Nm and, 114.9% less than 55 Nm. Lastly, fastening on a hard joint in the waist down posture showed 75 Nm resulted in 112.4% less than 30 Nm and 65.6% less than 55 Nm; 55 Nm resulted in 22% less than 30 Nm.

While fastening on a soft joint in the chestdown posture, 30 Nm target torque resulted in 162.3% less than 55 Nm, 54.7% less than 75 Nm and fastening in the Hightoward posture using 75 Nm resulted in 290% greater displacement than 30 Nm and 233.5% less than 55 Nm. Fastening 75 Nm in the thighdown posture resulted in 290% greater

displacement than 30 Nm and 233.5% less than 55 Nm. Lastly, fastening 75 Nm in the waistdown posture was 179.5% greater than 55 Nm and, 37.5% greater than 30 Nm in addition to 55 Nm being 50.8% greater than 30 Nm.

A 3-way interaction of TargetTorque x Strategy x Hardness ($F=6.626$, $p=0.001$) was found for arm rotation (Figure 3Figure 28). Post hoc testing showed participants fastening on a hard joint using 30 Nm target torque with the TT strategy resulted in 80% less displacement compared to TS and, 83.2% less than TSS. Participants fastening 55 Nm target torque using TT resulted in 75.7% less angular displacement than TS and, 72.1% less than TSS. Lastly, participants fastening 75 Nm target torque using TT resulted in 85.8% less than TS and, 86.8% less than TSS on a hard joint.

Participants fastening a 55 Nm target torque on a soft joint using TT resulted in 31.9% less than TS and, 32.6% less than TSS. Lastly, participants fastening 75 Nm target torque using TT resulted in 19.1% less displacement than TS.

4.2.4 ELBOW FLEXION

A 3-way interaction of Hardness x Posture x TargetTorque ($F=3.406$, $p=0.012$) was found for elbow flexion (Figure 29). Post hoc testing showed participants fastening on a hard joint in the chestdown posture using 30 Nm target torque resulted in 37.5% less displacement than 55 Nm target torque, 37.9% less displacement than 75 Nm and, 55 Nm target torque resulted in 61.2% less displacement than 75 Nm target torque. Participants fastening a soft joint in the chestdown posture using 30 Nm target torque resulted in 42.2% less displacement than 55 Nm target torque, 81% less displacement than 75 Nm target torque and, 55 Nm target torque resulted in 67.2% less displacement than 75 Nm target torque

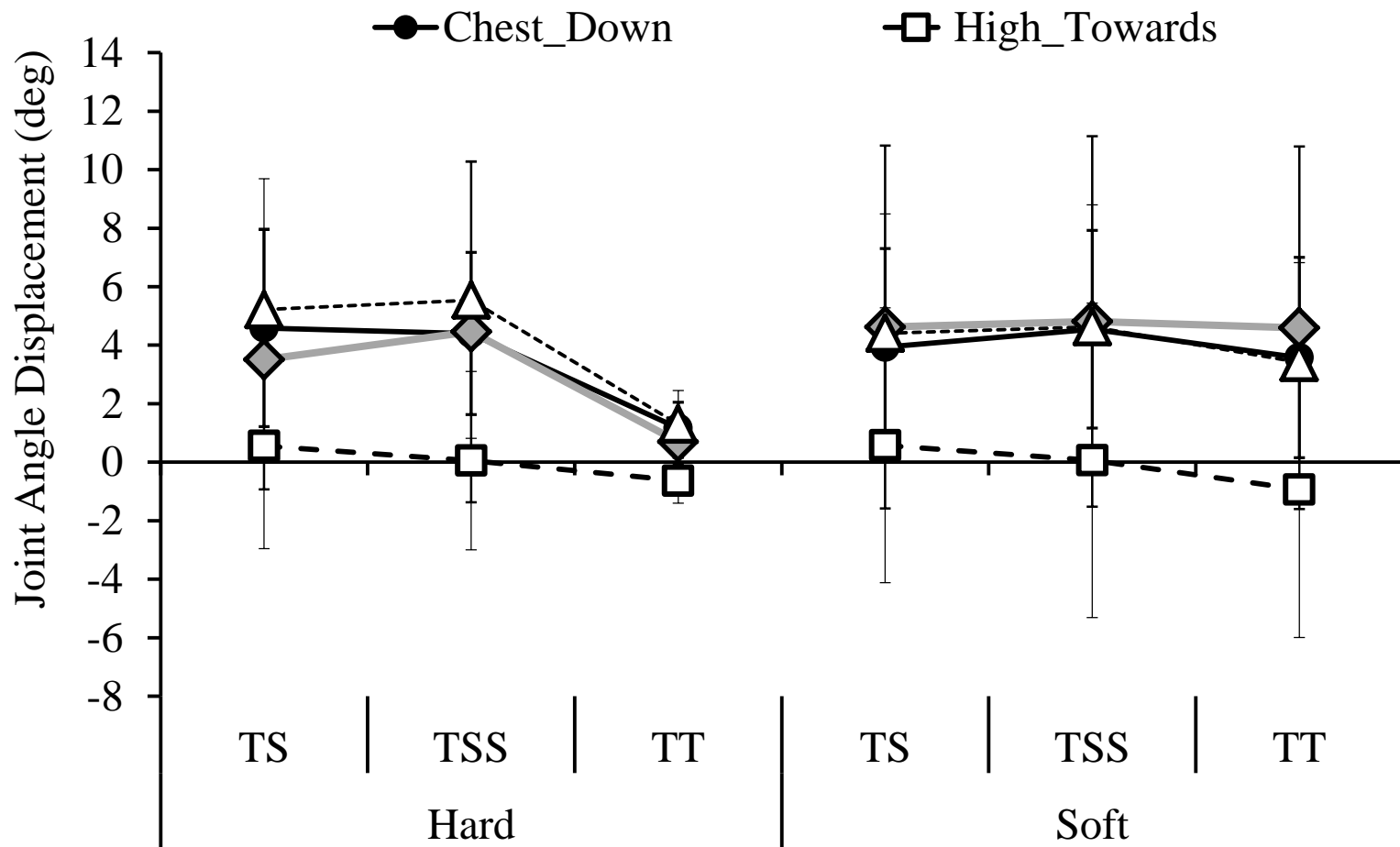

Figure 26: Average arm rotation angular displacement measured from torque initiation to 100ms post target torque, comparing tightening strategy and posture within hard and soft joint operation. Significantly less displacement was found while operating TT on all postures except hightowards. TSS showed the greatest advantage in hightowards posture..

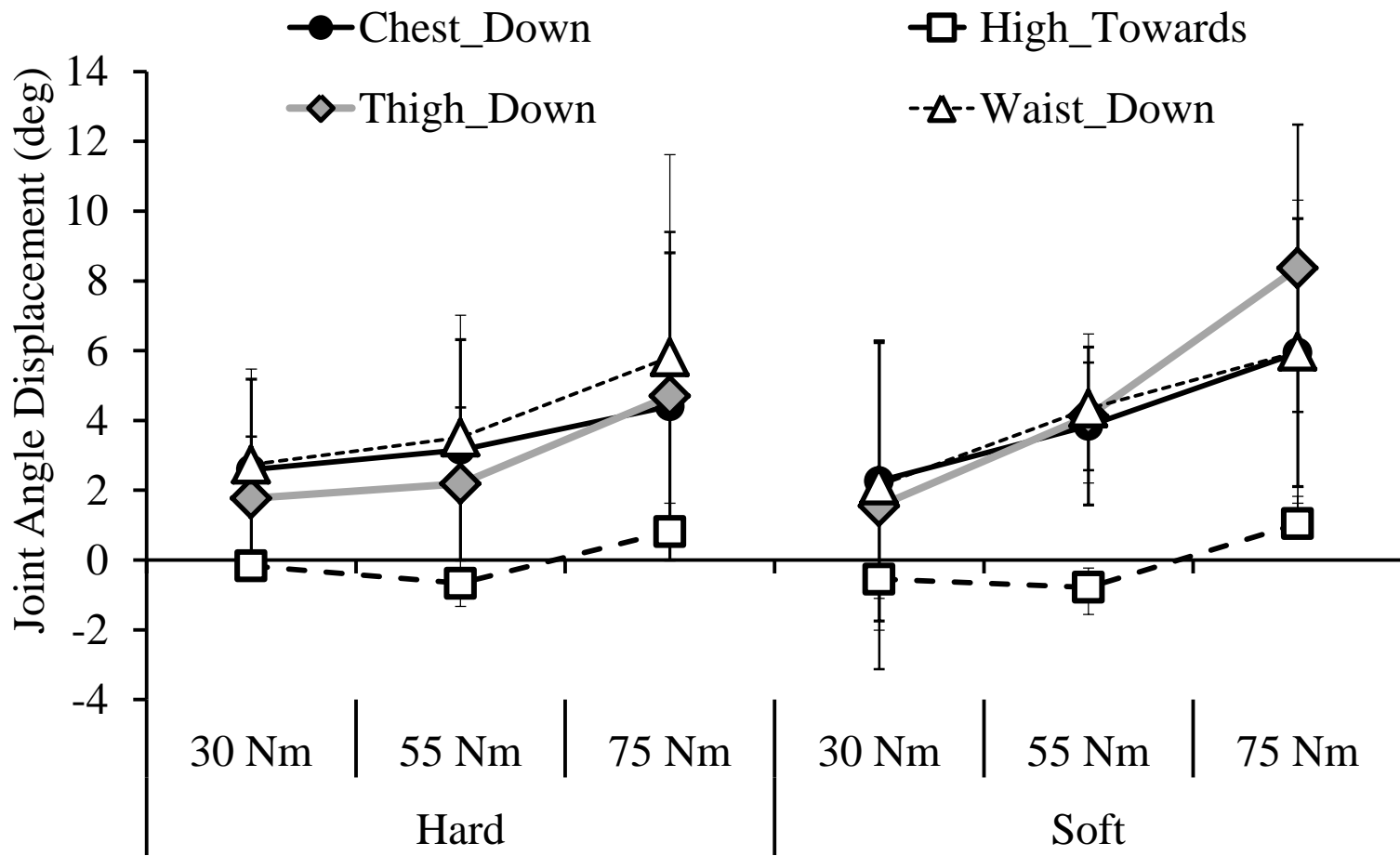

Figure 27: Average arm rotation angular displacement measured from torque initiation to 100ms post target torque, comparing target torque within each posture operating on hard and soft joints. Angular displacement was shown to increase with greater target torque regardless of operator posture.

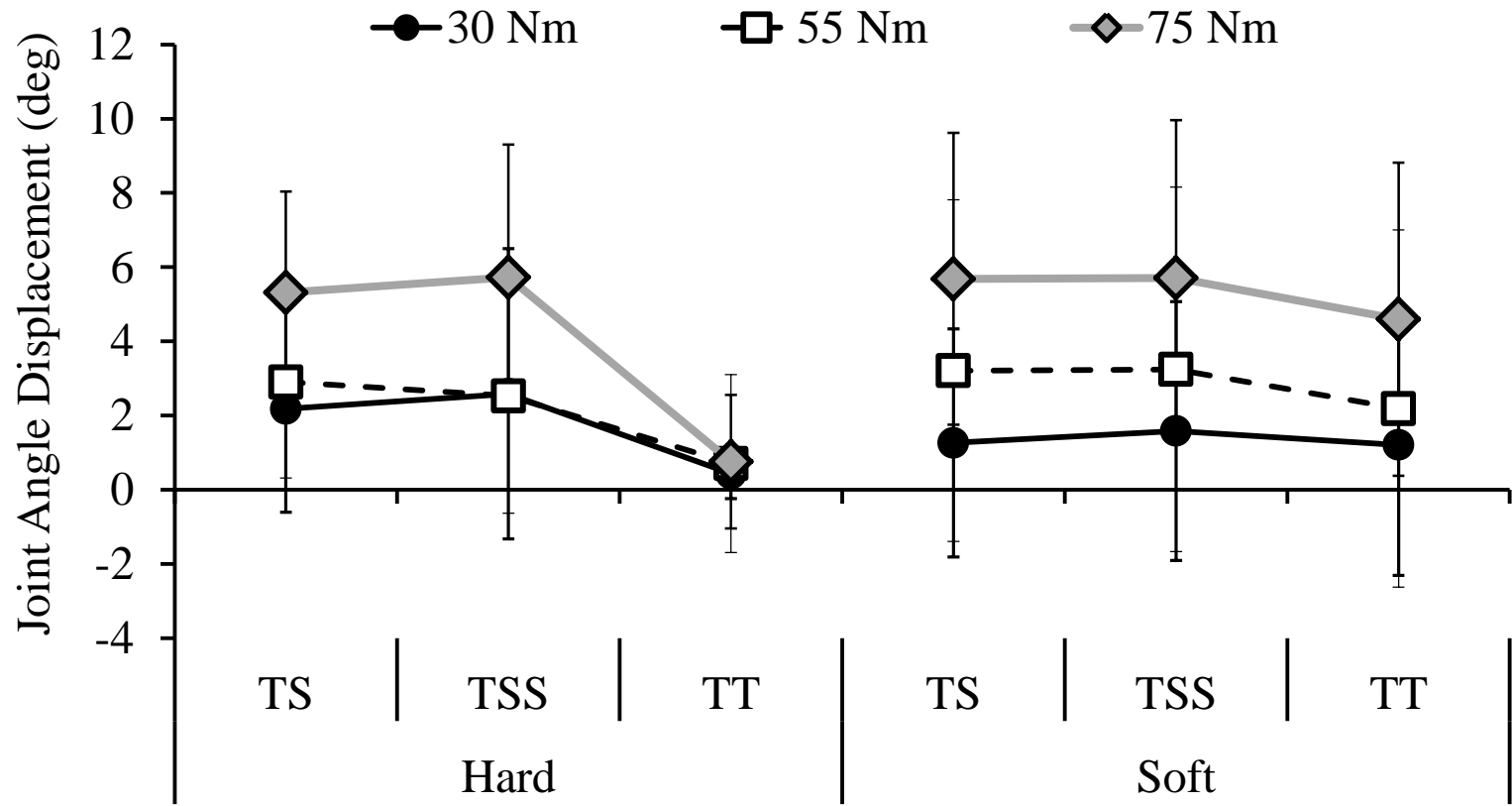

Figure 28: Average arm rotation angular displacement measured from torque initiation to 100ms post target torque, comparing tightening strategy during operation on hard and soft joints using increasing target torques. TT strategy was shown to have significantly less displacement compared to TS and TSS on hard joints.

Participants in the hightoward posture fastening on a hard joint using 30 Nm target torque resulted in 55.6% less displacement than 75 Nm target torque and, 55 Nm target torque resulted in 49.3% less displacement than 75 Nm target torque.

Participants fastening a soft joint in the hightoward posture using 30 Nm target torque resulted in 56.4% less displacement than 55 Nm target torque, 81.2% less displacement than 75 Nm target torque and, 55 Nm target torque resulted in 57% less displacement than 75 Nm target torque.

Participants in the thighdown posture fastening a hard joint using 30 Nm target torque resulted in 33.3% less displacement than 55 Nm target torque, 63.2% less displacement than 75 Nm target torque and, 55 Nm target torque resulted in 44.8% less displacement than 75 Nm target torque. Participants fastening a soft joint in the thighdown posture using 30 Nm target torque resulted in 68.2% less displacement than 55 Nm target torque, 83.7% less displacement than 75 Nm target torque and, 55 Nm target torque resulted in 48.8% less displacement than 75 Nm target torque.

Lastly, participants fastening a hard joint in the waistdown posture using 30 Nm target torque resulted in 54.8% less displacement than 75 Nm target torque and, 55 Nm target torque resulted in 44.6% less displacement than 75 Nm target torque. Participants in the waistdown posture fastening a soft joint using 30 Nm target torque resulted in 49.2% less displacement than 55 Nm target torque, 78.3% less displacement than 75 Nm target, and 55 Nm target torque resulted in 57.3% less displacement than 75 Nm target torque.

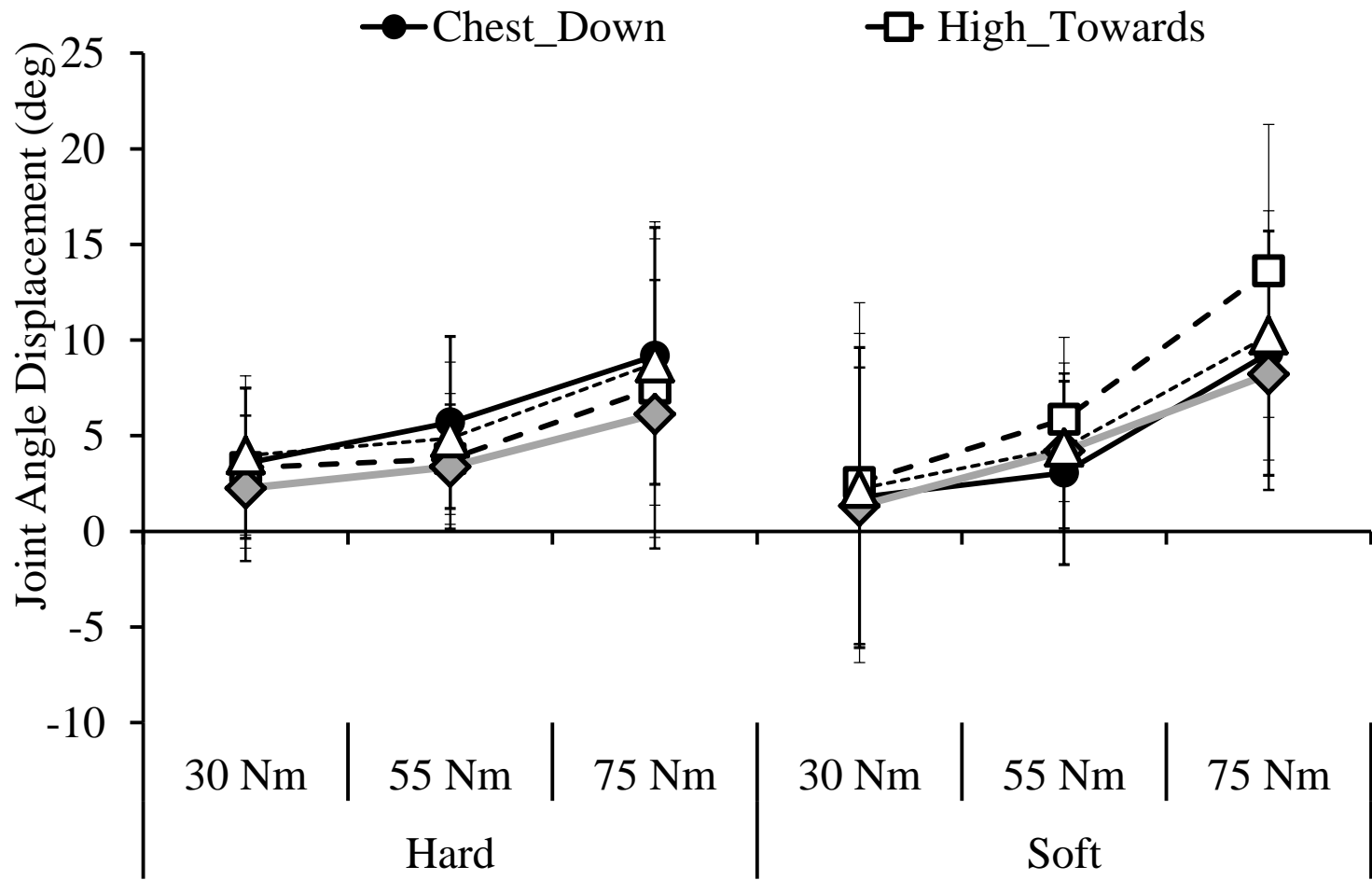

Figure 29: Average elbow flexion angular displacement measured from torque initiation to 100ms post target torque, comparing target torque and posture within hard and soft joint operation. Increasing torque was found to lead to increased angular displacement regardless of posture and joint hardness.

A 3-way interaction of Hardness x Posture x Strategy ($F=2.824$, $p=0.032$.) was found for elbow flexion (Figure 30). Post hoc testing showed participants fastening on a hard joint TT resulted in 15% less displacement than TS and, 73.4% less displacement than TSS. When fastening on a soft joint in the chestdown posture using TT resulted in 42.1% greater than TS and, 46.6% greater than TSS.

Operation in the high toward posture on a hard joint using TT resulted in 79% less displacement than TS and, 80.8% less displacement than TSS. Operation in the hightowards posture using soft joint did not result in any significance.

Participants fastening on a hard joint in the thighdown posture using TT resulted in 83% less displacement than TS, 87.4% less displacement than TSS and, TS resulted in 26.4% less displacement than TSS. Operation in the thighdown posture using soft joint did not result in any significance.

Lastly, operation on a hard joint in the waist down posture using TT resulted in 74.7% less displacement than TS and, 81.2% less displacement than TSS while TS resulted in 25.7% less displacement than TSS on a hard joint. Whereas, fastening on a soft joint in the waistdown posture using TT resulted in 30.8% greater displacement than TS and, 27.5% greater displacement than TSS.

A 3-way interaction of Hardness x TargetTorque x Strategy ($F= 35.44$, $p=0.007$) was found for elbow flexion (Figure 31). Post hoc testing showed participants fastening on a hard joint with 30 Nm target torque using TS resulted in 26.7% less displacement than TSS. Additionally, TT resulted in 68.3% less displacement than TS and, 76.7% less displacement than TSS. Participants fastening a 55 Nm target torque using TT resulted in

72% less displacement than TS and, 77.9% less displacement than TSS. Lastly, fastening on a hard joint with 75 Nm target torque using TS resulted in 14.6% less displacement than TSS and, TT resulted in 80.2% less displacement than TS and 83% less displacement than TSS.

Participants fastening on a soft joint with 30 Nm target torque using TT resulted in 65% greater than TS and, 75% greater than TSS. No additional significance was found

4.3 BORG RATINGS

A 3-way interaction of TT x Strategy x Hardness ($F=2.8$, $p=0.043$) for the Borg ratings was found (Figure 32). Post hoc testing showed participants fastening 30 Nm hard joint using TT rated effort 33.3% less than TS and, 40% less than TSS. When fastening on a 55 Nm hard joint, post hoc testing showed that ratings for TT were 21.7% less than TS and, 17.4% less than TSS. For the 75 Nm hard joint, post hoc testing showed participants fastening the RAPT with TT rated their effort 60% less than TS and, 56% less than TSS. Finally, post hoc testing showed participants fastening 55 Nm soft joint using TSS rated efforts 13.5% less than TS, and fastening 75 Nm soft joint using TT rated 20% less than TS.

A 2-way interaction ($F=2.4$, $p=0.049$) was also found for Posture x Strategy (Figure 33). Post hoc testing showed fastening in the chestdown posture, subjective ratings for TT produced 16% less than the TS and, 16% less than TSS. In addition, post hocs revealed that while in the hightowards posture using the TT strategy produced 36% less than in the same posture with TS, and 28% less than when in this posture using TSS. Also, ratings while operating in the thighdown posture using the TT strategy produced

4.8% less than TS, and 30.4% less than TSS. Lastly, ratings while performing the TT in the waistdown posture fastening produced 18.2% less when in the same posture with TS and, 18.2% less than when in the same posture using TS

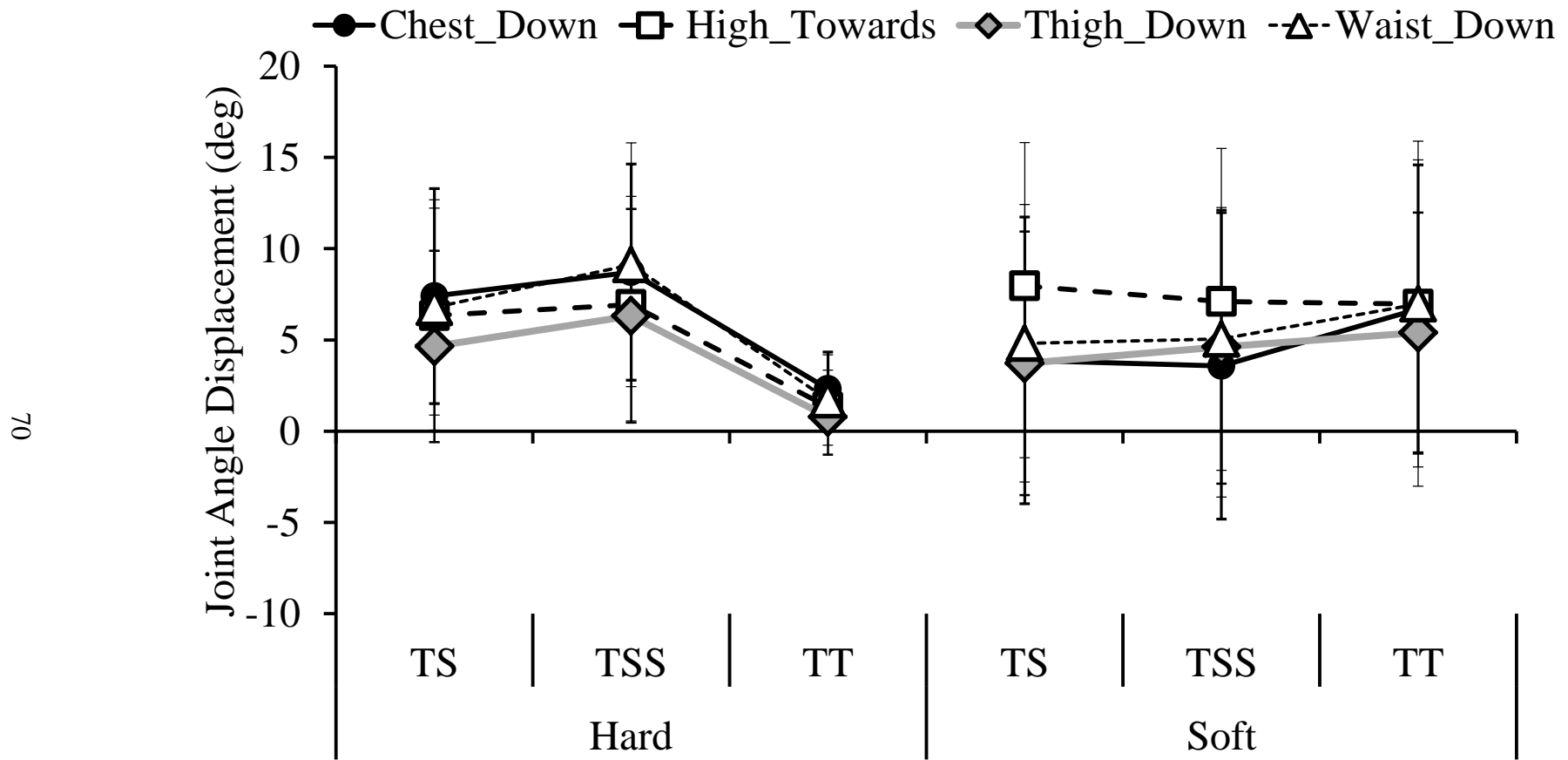

Figure 30: Average elbow flexion angular displacement measured from torque initiation to 100ms post target torque, comparing tightening strategy and posture within hard and soft joint operation. Operating on hard joints resulted in significantly less displacement while operating TT. Soft joints showed limited differences regardless of posture.

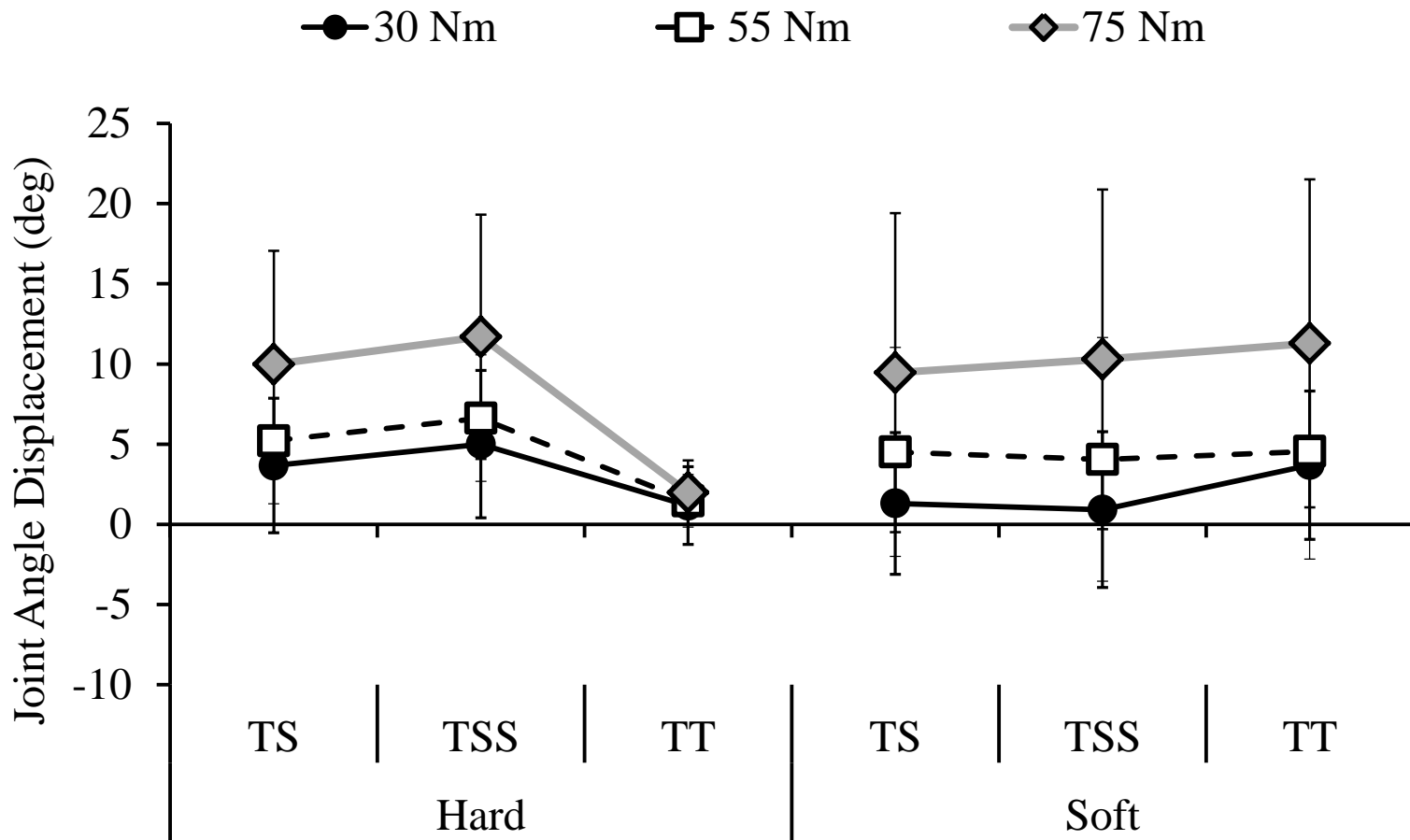

Figure 31: Average elbow flexion angular displacement measured from torque initiation to 100ms post target torque, comparing tightening strategy and target torque within hard and soft joint operation. Hard joint operation resulted in significantly less displacement while operating TT strategy compared to TS and TSS.

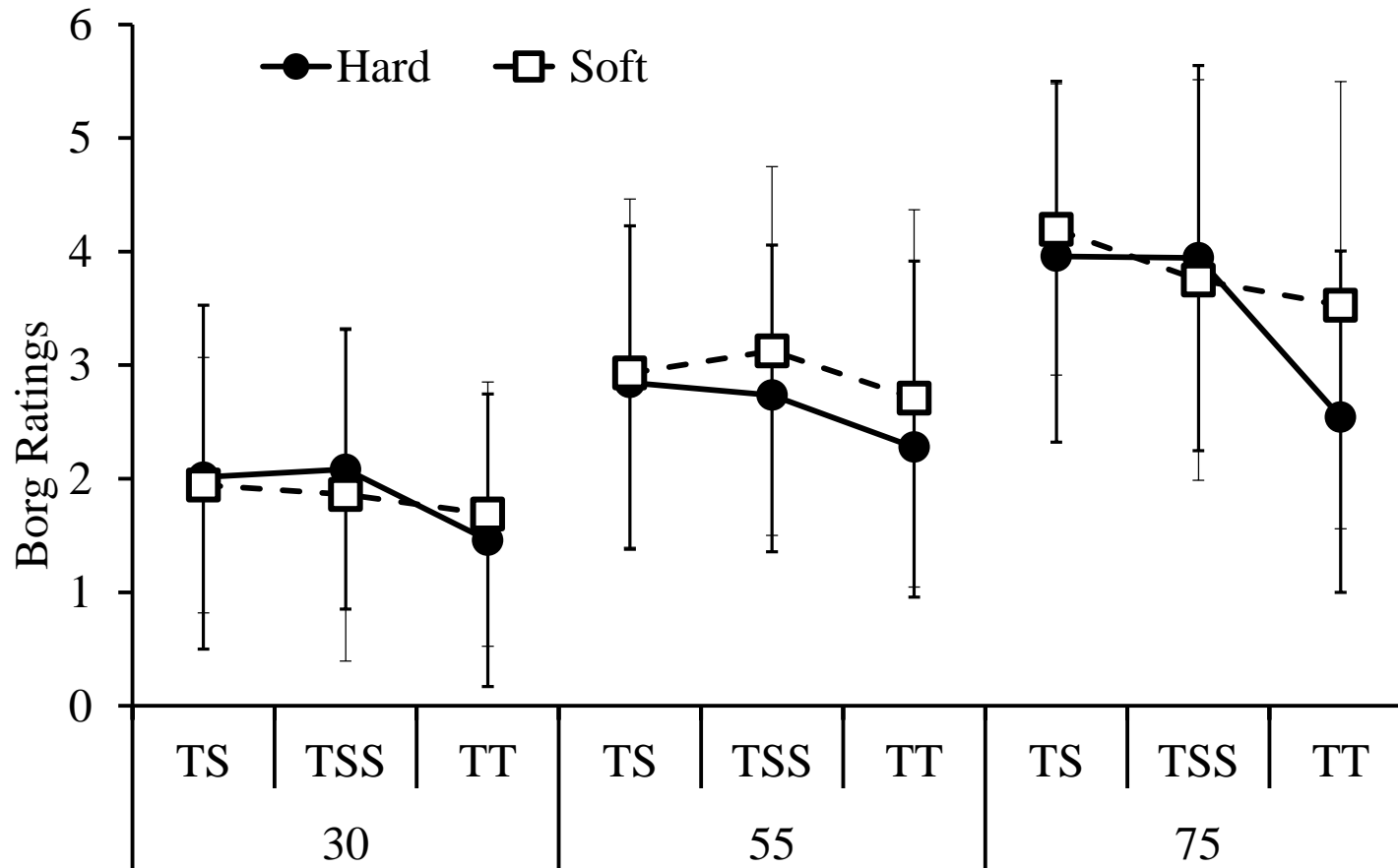

Figure 32: Subjective ratings for all participants comparing tightening strategies and target torque on hard and soft joints. TT resulted in the lowest ratings regardless of target torque on hard and soft joints

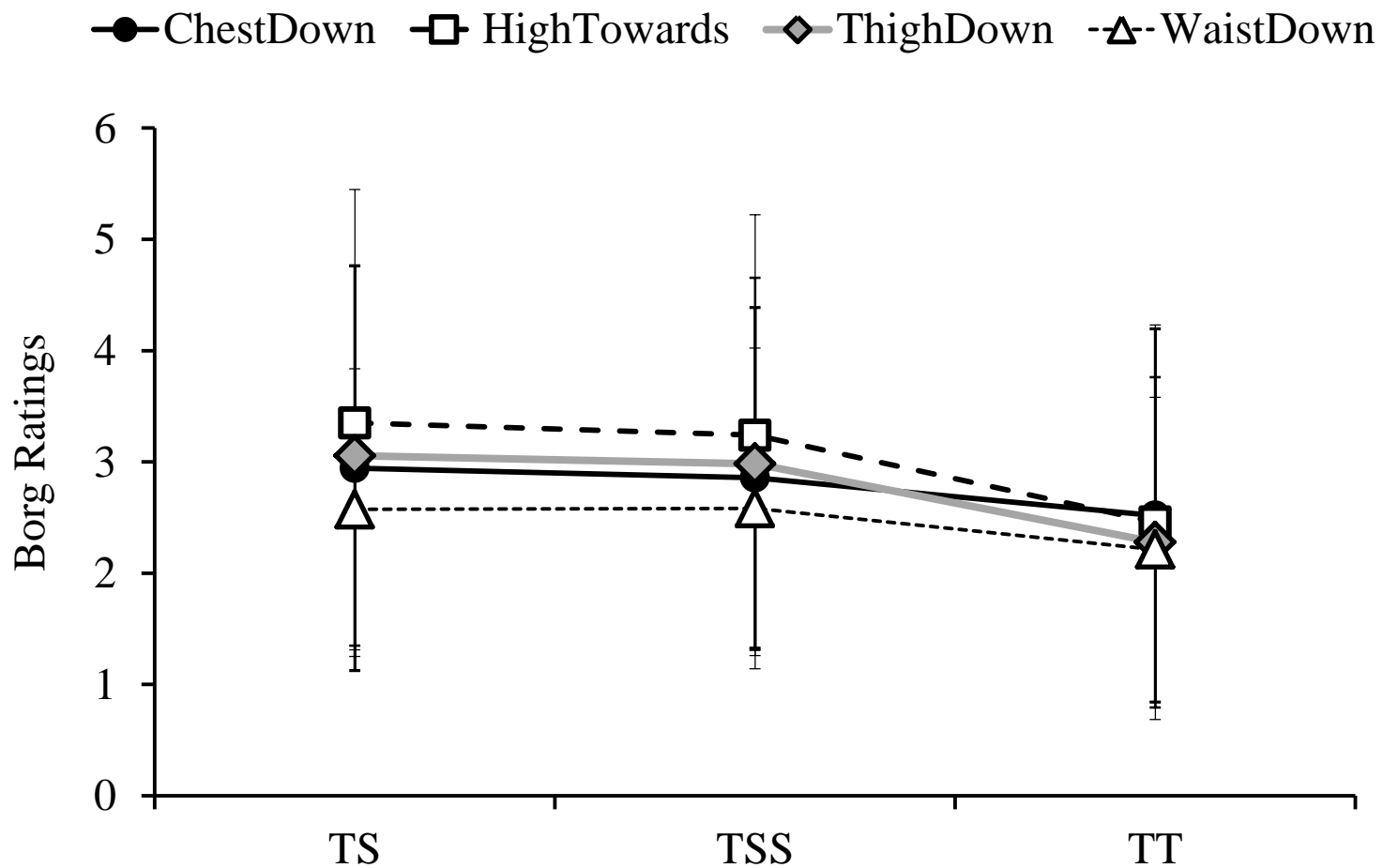

Figure 33: Average subjective ratings comparing tightening strategies within each of the four postures. TT resulted in lower discomfort ratings compared to TS and TSS regardless of posture.

Chapter 5: DISCUSSION

The results of this study have shown that forces experienced by the operator can be reduced by limiting torque build-up times as well as speeding up tool shut-offs, which in turn result in less arm displacement, all of which can provide a reduction in injury risk for power tool operation. Furthermore, through various testing it is apparent that the TT fastening strategy provided the least handle force impulse, joint angle displacement, and subjective ratings for participants. This follows the direction of previous research conducted by Kihlberg, Kjellberg and Lindbeck (1995) in which power tools, albeit pneumatically powered, with shorter build-up times and faster shut-off mechanisms, lead to the least hand-arm joint angle displacement, reaction forces and subjective ratings.

5.1 HANDLE FORCE IMPULSES

Handle forces in this study were measured through the use of an instrumented handle which included a 3D linear sensor. With the design of an offset handle, operators were able to grasp and maintain the RAPT in a similar fashion to what is experienced in manufacturing. The sensor, located inside of the handle, allowed for a direct recording of the forces experienced by the operator at the hand-handle interface. Although the handle attachment used in this study is a novel design, the use of instrumented handles is not. Lin and McGorry (2009) instrumented a handle with a strain gauge to determine tool torque impulse ratio using tool torque impulse and reaction hand moment impulse. Findings showed greater impulse ratios lead to greater discomfort. In comparison, studies by Lin, McGorry, Dempsey, Chang in 2006 and 2007 used an instrumented handle to determine grip forces associated with both pistol grip and RAPT operation. Although grip forces were not measured with the handle design method, Lin et al. (2006) found grip

strength was affected by joint hardness for pistol grip tools, but RAPTs were not affected. The researchers believed the participants in the study were familiar with tool use which led to limited variability with respect to grip strength.

Impulse forces rather than peak forces were reported in this study in order to account for the cumulative effect of force throughout the duration of each fastening; allowing for a greater understanding of the effect of the entire rundown within each tightening strategy. Freivalds (1993) expressed a similar belief in the use of force impulse to evaluate power tool ergonomics as opposed to peak force. The handle force data showed that the TT strategy resulted in the lowest handle force impulse regardless of target torque and posture. Each of the three fastening strategies varied in time to completion which helps to explain the time portion associated with impulse as TT was the quickest strategy (Hard: 0.36s, Soft: 0.57s) followed by TS (Hard: 0.55s, Soft: 0.98s) and TSS (Hard: 0.64s, Soft: 1.21s). However, the overall forces experienced at the handle were also reduced, which is shown when simply examining the peak force (not the scope of this thesis), when using TT (up/down (Fx): 19.8 N, push/pull (Fy):77.9 N, in/out (Fz):-3.1 N) compared to TS (up/down (Fx): 31.8 N, push/pull (Fy):99.7 N, in/out (Fz):-7.9 N) and TSS (up/down (Fx): 31.1 N, push/pull (Fy):102.3 N, in/out (Fz):-6.3 N).

The TT strategy uses a high spindle head rotation (~500 rpm) at the beginning of fastening and reduced speeds once target torque is achieved. The controller algorithm uses initial torque, final angle, target torque, and torque rate to ensure appropriate energy is supplied to the joint; and that target torque is achieved as fast as possible. The theory behind TT is to use the inertial properties of the tool (both radius of gyration and mass) to counteract the momentum that is created by the spinning of the spindle head of the tool.

The reduction of RPMs at the end of joint fastening also ensured shut-off occurred more rapidly than the TS and TSS fastening strategies used in this study. The tightening strategy developed by Atlas Copco proved to reduce handle force impulse, with a significant reduction in handle forces especially on hard joints.

5.2 JOINT ANGLES

The methodology used in this study aimed to gain a deeper understanding of how the arm-hand-handle interface reacts to various handle forces. In order to understand the risk of injury during power tool operations, shoulder displacement was identified during various fastening protocols. Differences between the three fastening strategies used in this study were able to show reduced torque build-up time and shut-off times (TT) resulted in a reduction of shoulder adduction, flexion and rotation angular displacement. The TT strategy had the shortest torque build-up times, fastest shutoff speed and lowest force impulse of the three strategies. The reduced forces and build-up times, and quicker shut-off speed increased the ability of the operator to resist handle displacement in the push/pull (F_y) direction; and limit joint angle displacement. Results determined the TT strategy resulted in less displacement than both TS and TSS on hard joints regardless of posture. However, the same benefit of lower displacement was not found when TT was used to fasten soft joints. This result can be attributed to TT limitations with joints greater than 270° due to increased fastening time resulting increased forces experienced by the operator (Atlas Copco, 2013). Atlas Copco has admitted that TT was never designed for soft joints, but maintaining their belief that reducing fastening time results in a decrease of forces through the amount of energy being transferred to the operator, it is hypothesized that the same benefits for soft joints could be made if the speed is increased

above 500 rpm. The findings of the current study are similar to those from Kihlberg, Kjellberg and Lindbeck (1993, 1994) where pneumatic power tools requiring longer time to shut-off were found to result in greater forward shoulder motions compared to immediate shut-off mechanisms. Kihlberg, Kjellberg and Lindbeck (1994) also found arm motion was greater when strategies involved delayed shut-off mechanisms, which maintained target torque for a longer period of time, compared to slow shut-off mechanisms with increasing torque. However, the increased torque did not cause increased forces and motions for fast shut-off tools which were believed to be caused by the inertial properties of tools used in the study. The TT strategy is designed with a specific algorithm which controls the tool's motor, calculated from the rotor inertia and rotor speed, in order to ensure the energy being produced is equal to the torque experienced at the joint (Atlas Copco, 2005). This results in decreased torque build-up times and quicker tool shut-offs, which have been shown to improve operator joint angle displacement and handle stability. Handle stability during RAPT fastening can be used to identify the risk associated with a specific tightening by investigating the biomechanical risk developed when the forces experienced at the hand-handle interface exceed the capability of the operator. When the handle forces experienced by the operator increase, the likelihood of tool displacement occurs, which in turn leads to an increased risk of joint angle displacement and, ultimately eccentric muscle contraction. Eccentric muscle contractions have been linked to delayed onset muscle soreness and muscle tissue damage (Sommerich, Gumpina, Roll, Le, Chandler, 2009). Therefore, any tightening strategy should aim to minimize the forces that cause forced arm movements by reducing torque build-up time, handle forces, by using the shortest tool shut-off possible. The

results of this study show that the TT strategy was the most acceptable biomechanical and ergonomically safe strategy when operating on hard joints. The three strategies used in this study resulted in functionally similar responses on soft joints. However, TT provide the shortest build-up times and fastest shut-off, therefore would be recommended for hard and soft joints alike.

5.3 HANDLE DISPLACEMENT

In addition to handle forces and subjective ratings, Lin, McGorry, Chang and Dempsey (2007) found that handle displacement following the securing of a fastener can be influenced by several factors including working height, working distance and user experience. Past researchers (Lin et al., 2001, 2003, 2006' Lindqvist, 1993) have modelled the hand arm system as a passive mechanical system made up of stiffness, moment of inertia and damping elements to predict handle displacement. Handle displacements occur when the forces experienced at the hand-handle interface exceed the force capability of the human operator. Once handle displacement occurs the hand is displaced, which results in a chain reaction up the hand-arm system leading to angular changes to the wrist, elbow and shoulder joints. Additionally, handle forces which lead to handle displacement can produce static stress and strain to operator's limbs which in turn can lead to dynamic stress and strain which all lead to increased risk of developing injuries and disorders related to power tool usage (Dong, Wu & Welcome 2005). Angular displacement of the elbow is directly related to hand-handle displacement as the hand arm system is mechanically connected.

This study found posture to have significant interactions with target torque, fastening strategy and joint hardness for shoulder joint displacement as well as elbow

displacement. TT strategy provided the lowest angular elbow displacement regardless of target torque and posture; no differences were noted when operating on soft joints between the three tightening strategies.

5.4 SUBJECTIVE RATINGS

The 10-point Borg scale used in this study was modified from Kihlberg, Kjellberg and Lindbeck's (1993) study where operators discomfort ratings using delayed shut-off tools compared to quicker shut-off tools. Following each 5 minute, trial, (25 fastenings) participants were asked to rate their effort and discomfort level in order to gain an understanding of how inexperienced tool operators assessed each posture, target torque and strategy from a subjective standpoint. Participant ratings were shown to be significantly less for operations using TT compared to TSS and TS fastening strategies on 75 Nm hard joints only. Hard joints using 30 Nm and 55 Nm target torques, as well as, soft joints were not shown to have any significant differences. Additionally, participants' effort and discomfort ratings were shown to increase on average as target torque increased; while posture did not have an effect on subjective ratings. One explanation for the increase in discomfort during increased target torque is the resulting force experienced at the handle. As target torque increases, so does the effort required to maintain handle stability during tightening. Therefore, operators are required to exert a greater force on the handle, which leads to increased perceived discomfort. A compounding effect can be viewed when we identify the time required for each tightening strategy. The results from this study identify TT as the quickest tightening strategy, and the strategy that resulted in the least force experienced at the handle. Thus,

it would be expected that the reduced time and reduced forces would result in the lowest operator discomfort and effort ratings.

In addition to discomfort and strength ratings, Borg scales have been used to determine task acceptability. Kihlberg, Kjellberg and Lindbeck (1995) used subjective ratings of discomfort, in addition to a question of operator acceptance, to identify acceptability limits with pneumatic RAPT. Oh and Radwin (1998), found subjective ratings did not differ significantly between horizontal and vertical workstations on perceived exertion or task acceptance. Although task acceptance was not measured in this study, results showed higher discomfort ratings for the posture associated with vertical orientation compared to the horizontal workstations.

Findings from this study provide evidence that subjective ratings should not be used as a singular method of identifying acceptable RAPT fastening. Although ratings provided by the novice participants were shown to have statistical significance, limited clinical significance was found. Handle forces and joint angle displacement provide greater indication when attempting to understand the human interaction during RAPT fastening. Therefore, handle force and joint angular displacement should be implemented in future research rather than subjective ratings.

5.5 HYPOTHESES REVISTED

1) Elbow displacement (surrogate of handle) will show a statistically significant ($p < 0.05$) interaction between fastening strategy and target torque measured from initiation of torque to 100 ms post peak torque.

Through the examination of the hand-arm system of operators as a single entity it can be hypothesized that greater handle displacement leads to greater flexion/extension angular displacement of the elbow. Based on this, a significant interaction was found between joint hardness, target torque and fastening strategy. Hard joints resulted in the least angular displacement when using the TT strategy. While fastening on a soft joint, TT was found to result in significantly larger displacement only when securing a 30 Nm joint. These results support the findings from Kihlberg, Kjellberg, Lindbeck's (1994) in which fast shut-off mechanisms were found to produce the least handle displacement. The TSS fastening strategy used in this study included the longest shut-off mechanisms and was found to be significantly higher than TT, which contained the quickest build-up time and shut-off speed for hard joint operation.

2) Shoulder joint angle displacement will show a statistically significant interaction between Fastening strategy, target torque and posture as measured from initiation of torque to 100 ms following peak torque.

The results from this study show significant shoulder angular adduction displacement interactions between posture, target torque and strategy. Although shoulder flexion and shoulder rotation did not show significance between the three variables, significant interactions were found between posture and strategy, posture and target torque, as well as, target torque and strategy.

Kihlberg, Kjellberg and Lindbeck (1993, 1994) found a positive relationship between shoulder displacement and tool shut-off speed. The positive correlations were also found between the operation motions, ground reaction forces and subjective ratings.

However, the main difference between our study and Kihlberg, Kjellberg and Lindbeck's series of studies is the investigation of the operator's arm angular displacement. During Kihlberg et al. (1993), study the arm was shown to move as a pendulum with a spatially fixed point about the shoulder. The results of this study indicate that it is important to evaluate the shoulder and elbow separately as opposed to a single pendulum to understand the full kinematic impact of RAPT fastening.

3) Subjective ratings will be greater for DC TSS compared to DC TS and DC TT fastening strategies ($p < 0.05$).

Results from this study show the TSS tightening strategy was statistically greater than TT but not TS. In fact, fastening on a hard joint using 55 Nm found TSS rating statistically lower than TT and TS. A study by Kihlberg, Lindbeck and Kjellberg (1993) used equal spindle torque speeds to determine the speed of tool shut-off has an effect on perceived exertion. Furthermore, findings are in agreement with this study as delayed shut-off tools resulted in high subjective ratings compared to quick shut-off tools. Furthermore, tool run-down control techniques and torque profiles can be used to limit discomfort on top of shut-off times (Lindqvist, 1993).

4) Force impulse magnitudes occurring between initialization and target torque will be statistically lower ($p < 0.05$) when fastening the DC TT right angle power tool compared to DC TSS and DC TS fastening strategies.

The results showed the TT tightening strategy provide a reduced force impulse compared to TS and TSS strategies. The TT strategy was found to have the shortest torque build-up times as well as forces impulse which resulted in significantly less pull (F_y) force

impulse compared to TS and TSS. In addition to the push/pull (F_y) force, The TT strategy resulted in the least up/down (F_x) force impulse regardless of fastening orientation, posture and target torque.

Chapter 6: CONCLUSION

In conclusion, regardless of operator posture or target torque, findings from this study showed significantly less handle force impulse, shoulder and elbow joint displacement, and subjective ratings when using the TurboTight® strategy compared to Two-Stage and Two-Stage Soft Stop strategies. The differences found can be explained by the tightening strategies themselves. The TurboTight® incorporated the shortest fastening time (0.47s) by implementing a high initial speed followed by a decreasing RPM as target torque increased. This control algorithm was designed to use the inertial effects of the tool to reduce the forces transferred to the operator, in an attempt to reduce the risk of injury. The overall reduction in handle forces, even when target torque increased, led to a reduction in joint angles and handle displacement; all of which help to reduce the risk of injury during RAPT operation. In addition to the force and joint angle displacement, subjective ratings showed operators preferred the TurboTight® strategy during the testing protocol.

6.1 LIMITATIONS AND ASSUMPTIONS

In this study some limitations and assumptions were made regarding the participants, tightening strategies, joint simulators, and subjective ratings, all which deserve some discussion. Participants included in the study were identified as non-experienced, healthy individuals from the general population. Six males and six females from three age groups

were chosen to represent the working population. Prior to data collection, participants were asked a series of questions in order to prevent experienced or injured individuals from participating. It is assumed questions were answered truthfully and the population chosen to participate was a true representation of the general population. Inexperienced operators were chosen to participate in this study in order to determine the kinematic effects of novice operators, who have no familiarity, nor developed physiological advantages to power tool operation. Inexperienced tool operators more commonly experience unexpected events and are more likely to be injured (Reynolds, 2009).

Secondly, the joint simulators used in this study consisted of bolt and washer fittings with hard (30^0) and soft (540^0) joint properties. Following each fastening, the investigator loosened the bolt in anticipation of the following fastening. Loosening distance was not monitored and may have influenced results due to increased rundown phases. Additionally, the joints were lubricated prior to each data collection to ensure joint stability. Lubrication was applied by the investigator with a paint brush and could have resulted in differences between subjects.

Thirdly, the three tightening strategies used in this study were programmed by the researching team. When contacting Atlas Copco, the trained expert stated each controller and strategy implemented in the manufacturing world is tuned to fit the specific task at hand. Therefore, strategies used in this study were specific to the lab environment without professionally trained individuals.

Lastly, the CR-10 Borg scale shown to participants following each trial was chosen based on its simple nature and ability to guide participants to quick ratings.

Kihlberg, Kjellberg, & Lindbeck (1993, 1994) used the same CR-10 scale which was believed to be reliable. It was also assumed that participants were truthful and honest when providing ratings. However, some participants expressed discomfort during trials with reduced operator effort, resulting in confusion when choosing a single rating. Separate ratings for effort and discomfort would have potentially provided more insight into operator ratings regarding the three tightening strategies used.

6.2 IMPLICATIONS FOR INDUSTRY

The tooling, joint types, postures and strategies incorporated in this study were chosen to replicate real world manufacturing jobs in a lab environment. Therefore, the results and findings from this study are considered representative to RAPT operation in the world of manufacturing. When possible, DC tools should be implemented into all workstations/operations in order to provide greater control of fastening strategies. Greater control tightening strategies allow manufacturing companies the ability to reduce the risk of injury through limiting the duration and, level of forces experienced by the operator at the hand-handle interface. Past research has shown, when choosing a tightening strategy, the following should be considered; limiting the time required to achieve target torque, reducing the time required for tool shut-off once target torque is achieved and limiting low speeds during fastening (Kihlberg, Kjellberg, & Lindbeck 1995). Based on this direction, the TurboTight® strategy was proven to be the most ergonomically friendly strategy used in this study.

6.3 FUTURE RESEARCH DIRECTIONS

Future studies should expand upon the TurboTight® strategy findings from this study to ensure not only ergonomic requirements are met, but also durability and quality associated with the specific application. Additionally, other tool suppliers with similar tightening strategies should be investigated to identify the most ergonomically acceptable tightening strategy and, provide a non-biased study. Future RAPT studies should also be wary of how participants report subjective ratings if collected. Researchers should report effort and discomfort using separate subjective reports rather than incorporate both into a single rating. Results from this study were not clinically relevant, which were believed to be a result of participants providing a single rating based on discomfort and effort. Lastly, future research should investigate a wide range of joint hardness to ensure the most appropriate tightening strategy for a greater range of joint angle rotations.

REFERENCE LIST

- Aminian, K., & Najafi, B. (2004). Capturing human motion using body fixed sensors: outdoor measurement and clinical applications. *Computer Animation and Virtual Worlds*, 15(2), 79-94.
- Atlas Copco. (2005). Power focus quick guide. Retrieved from Atlas Copco
[http://194.132.104.143/websites/tools/Publications/acc11.nsf/va_TechLang/78CD B32776CFE6B9C1256D39002F812B/\\$File/Power_Focus_Quick_Guide_UK.pdf?OpenElement](http://194.132.104.143/websites/tools/Publications/acc11.nsf/va_TechLang/78CD B32776CFE6B9C1256D39002F812B/$File/Power_Focus_Quick_Guide_UK.pdf?OpenElement)
- Atlas Copco. (2013). Pocket guide to TurboTight. Retrieved from
<https://www.scribd.com/document/332819527/Atlas-Copco-Pocket-Guide-TurboTight-UK>
- Atlas Copco. (2014a). Inline nutrunners. Retrieved from
<http://www.atlascopco.ca/caus/products/assembly-tools/1401319/1467997>
- Atlas Copco. (2014b). Pistol grip nutrunner. Retrieved from
<http://www.atlascopco.ca/caus/products/assembly-tools/1401319/1468381>
- Atlas Copco. (2014c). Tensor ETV DS72-100-13: Electric Angle Nutrunner. Retrieved from <http://www.atlascopco.ca/caus/products/assembly-tools/1401319/1459438/>
- Atlas Copco Industrial Technique AB. (2013). User guide: Power Focus. In (18.2 ed.) Atlas Copco.

- Borg, E., & Borg, G. (2002). A comparison of AME and CR100 for scaling perceived exertion. *Acta Psychologica.*, 109(2), 157-175.
- Borg, G. (1990). Psychophysical scaling with applications in physical work and the perception of exertion. *Scandinavian Journal of Work, Environment & Health*, 16 Supplement 1, 55-58. doi:1815
- Borg, G. A. (1982). Psychophysical bases of perceived exertion. *Medicine and Science in Sports and Exercise*, 14(5), 377-381.
- Bureau of Labor Statistics. (2012). Nonfatal occupations injuries and illnesses requiring days away from work. Retrieved from http://www.bls.gov/news.release/archives/osh2_11262013.pdf
- Bureau of Labor Statistics. (2013). Nonfatal occupations injuries and illnesses requiring days away from work. Retrieved from http://www.bls.gov/news.release/archives/osh2_11262013.pdf
- Chaffin, D. B., & Faraway, J. J. (2000). Stature, age, and gender on reach motion postures. *Human Factors* 42, 408-420.
- Cole, G. K., Nigg, B. M., Ronsky, J. L., & Yeadon, M. R. (1993). Application of the joint coordinate system to three-dimensional joint attitude and movement representation: a standardization proposal. *Journal of Biomechanical Engineering*, 115, 344-349.

- Figueroa, P. J., Leite, N. J., & Barros, R. M. (2003). A flexible software for tracking of markers used in human motion analysis. *Computer Methods and Programs in Biomedicine*, 72(2), 155-165.
- Forsman, M., Cyrén, H., Möller, T., Kadefors, R., & Mathiassen, S. E. (2002). Activity in five muscles during joint securing using pneumatic nutrunners. *International Journal of Industrial Ergonomics*, 29(1), 21-32. doi: 10.1016/S0169-8141(01)00046-4.
- Freivalds, A., & Eklund, J. (1993). Reaction torques and operator stress while using powered nutrunners. *Applied Ergonomics*, 24(3), 158-164.
- Furniss, M. (1999). Motion capture. Retrieved from <http://web.mit.edu/mit/articles/indexfurniss.html>.
- International Standards Organization. (1994). International Standards 5393-Rotary tools for threaded fasteners - Performance test method International Standards Organization.
- Kihlberg, S., Kjellberg, A., & Lindbeck, L. (1993). Pneumatic tool torque reaction: reaction forces, displacement, muscle activity and discomfort in the hand-arm system. *Applied Ergonomics*, 24(3), 165-173.
- Kihlberg, S., Kjellberg, A., & Lindbeck, L. (1995). Discomfort from pneumatic tool torque reaction: acceptability limits. *International Journal of Industrial Ergonomics*, 15(6), 417-426. doi: 10.1016/0169-8141(94)00059-C.

- Kihlberg, S., Lindbeck, L., & Kjellberg, A. (1994). Reaction forces, tool handle displacements and discomfort ratings during work with shut-off nutrunners. *Applied Ergonomics*, 25(4), 242-247.
- Kim, B.J. (2012). Effects of ergonomic design changes in handle tools on physiological cost and subjective ratings. *International Journal of Occupational Safety and Ergonomics*, 18 (2), 267-277.
- Kim, K. H., Reed, M. P., & Martin, B. J. (2010). A model of head movement contribution for gaze transitions. *Ergonomics*, 53(4), 447-457.
doi:10.1080/00140130903483713.
- Ku, C. H., Radwin, R. G., & Karsh, B. T. (2007). Power hand tool kinetics associated with upper limb injuries in an automobile assembly plant. *Journal of Occupational and Environmental Hygiene*, 4(6), 391-399. doi: 10.1080/15459620701326521.
- Lin, J. H., McGorry, R. W., & Chang, C. C. (2007). Hand-handle interface force and torque measurement system for pneumatic assembly tool operations: suggested enhancement to ISO 6544. *Journal of Occupational Environmental Hygienist*, 4(5), 332-340. doi:773427728
- Lin, J. H., McGorry, R. W., Chang, C. C., & Dempsey, P. G. (2007). Effects of user experience, working posture and joint hardness on powered nutrunner torque reactions. *Ergonomics*, 50(6), 859-876. doi: 10.1080/00140130701237618.
- Lin, J. H., Radwin, R. G., & Richard, T. G. (2001). Dynamic biomechanical model of the hand and arm in pistol grip power handtool usage. *Ergonomics*, 44(3), 295-312.

- Lin, J. H., Radwin, R. G., & Richard, T. G. (2003). A single-degree-of-freedom dynamic model predicts the range of human responses to impulsive forces produced by power hand tools. *Journal of Biomechanics*, 36, 1845-1852.
- Lin, J. H., & McGorry, R. W. (2009). Predicting subjective perceptions of powered tool torque reactions. *Applied Ergonomics*, 40(1), 47-55. doi: 10.1016/j.apergo.2008.01.020.
- Lin, J. H., McGorry, R. W., Dempsey, P. G., & Chang, C. C. (2006). Handle displacement and operator responses to pneumatic nutrunner torque buildup. *Applied Ergonomics*, 37(3), 367-376. doi: 10.1016/j.apergo.2005.05.013.
- Lin, J. H., Radwin, R. G., Fronczak, F. J., & Richard, T. G. (2003a). Forces associated with pneumatic power screwdriver operation: statics and dynamics. *Ergonomics*, 46(12), 1161-1177. doi: 10.1080/0014013031000139518.
- Lindqvist, B. (1993). Torque reaction in angled nutrunners. *Applied Ergonomics*, 24(3), 174-180.
- Lyttelton, O. (2014). A brief history of motion-capture, from Gollum to Caesar. Retrieved from <https://www.yahoo.com/movies/a-brief-history-of-motion-capture-in-the-movies-91372735717.html>.
- Massion, J. (1992). Movement, posture and equilibrium: interaction and coordination. *Progress in Neurobiology*. 38(1), 35-56. doi:0301-0082(92)90034-C

- Massion, J., Alexandrov, A., & Frolov, A. (2004). Why and how are posture and movement coordinated? *Progress in Brain Research*, 143, 13-27. doi:S0079-6123(03)43002-1
- Moeslund, T. B., & Granum, E. (2001). A survey of computer vision-based human motion capture. *Computer Vision and Image Understanding*, 81(3), 231-268.
- Oh, S. A., & Radwin, R. G. (1997). The effects of power hand tool dynamics and workstation design on handle kinematics and muscle activity. *International Journal of Industrial Ergonomics*, 20(1), 59-74.
- Oh, S. A., & Radwin, R. G. (1998). The influence of target torque and torque build-up time on physical stress in right angle nutrunner operation. *Ergonomics*, 41(2), 188-206. doi: 10.1080/001401398187242.
- Oh, S., & Radwin, R. G. (1994). Dynamics of power hand tools on operator hand and arm stability. *Proceedings of the Human Factors and Ergonomics Society Annual Meeting*, 38(10), 602-606. Retrieved from <http://pro.sagepub.com/content/38/10/602.abstract>
- Potvin, J. R., Agnew, M. J., & Ver Woert, C. (2004). An ergonomic comparison of pneumatic and electrical pistol grip hand tools. *International Journal of Industrial Ergonomics*, 34, 467-478.
- Radwin, R. G., Vanbergeijk, E., & Armstrong, T. J. (1989). Muscle responses to pneumatic hand tool torque reaction forces. *Ergonomics*, 32, 665-673.

- Radwin, R. G., Chourasia, A. O., Howery, R. S., Fronczak, F. J., Yen, T. Y., Subedi, Y. et al. (2014). Factors influencing power hand tool fastening accuracy and reaction forces. *Human Factors: The Journal of the Human Factors and Ergonomics Society*, 56(4), 657-668.
- Reed, M. P., Parkinson, M., & Klinkenberger, A. (2003). Assessing the validity of kinematically generated reach envelopes for simulations of vehicle operators. *Society of American Engineers*, 1(2216), 1-5.
- Reynolds, Bob. "Teaching General Power Tool Safety." Power Tool Institute. Retrieved from www.powertoolinstitute.com/pti_pdfs/Teaching-General-Power-Tool-Safety-06-2016.pdf.
- Schafer, J. L., & Olsen, M. K. (1998). Multiple imputation for multivariate missing-data problems: A data analyst's perspective. *Multivariate Behavioral Research*, 33(4), 545-571.

APPENDIX A

SCRIPT

The Direct-Current (DC) RAPT setup for this study includes a right angle power tool (RAPT), power tool controller and simulated handle. The controller, connected to RAPT via a power cord, provides the parameters associated with joint fastening and collects information regarding the tool tightening. In addition to the controller and RAPT, a simulated handle is placed onto the RAPT in order to collect forces experienced at the handle.

For this study, you will be completing a series of DC RAPT fastenings. A DC RAPT is powered by electricity and is initiated with the pull of the trigger. Once a preset torque (rotational force) or angle is met, the tool will automatically shut-off.

In order to operate the tool, two hands will be placed on the RAPT as shown in picture below. The left hand will be placed on the spindle head while the right hand will be controlling the trigger. An instrumented handle will be attached to the tool, allowing for you to control the power source of the tool.

For data collection, your feet will be placed in a specified location on the ground and you will complete a series of joint fastenings per condition. Each condition will consist of 5 continuous minutes of joint fastenings. With one fastening completed every 12 seconds. Following the 5 minutes, you will receive two minutes of rest as well as provide a subjective rating of your perceived effort.

For the next 15 minutes you may practice with any variation of fastening setups you may experience during this study.

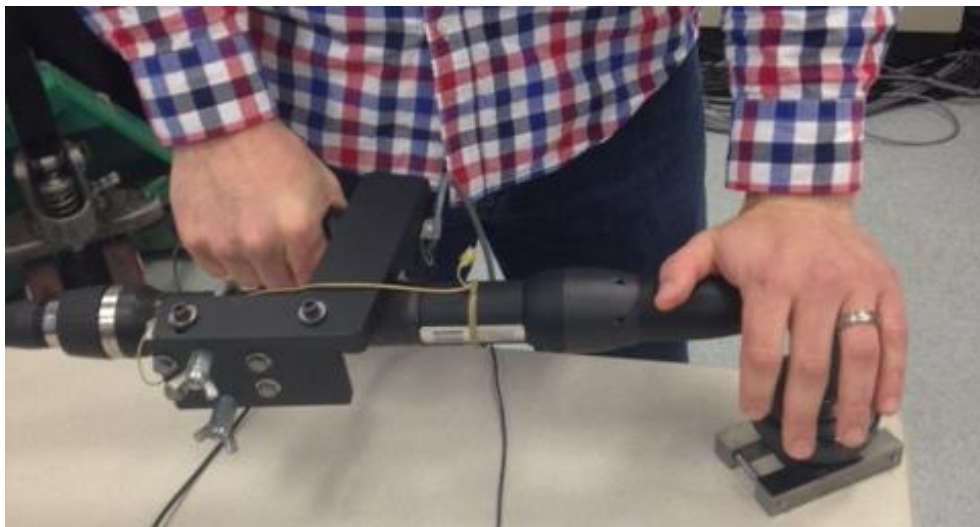

APPENDIX B

CONSENT FORMS

To whom it may concern,

The following individual participated in a study investigating the physical demands associated with direct-current right angle power tool operation. The participant completed a series of joint fastenings at various distances from the body using direct-current right angle power tools. The study aims to parameterize and quantify ergonomic factors (end-reaction torque and handle displacement) associated with right angle power tool usage in order to reduce work related musculoskeletal disorders and improve worker safety.

Name: _____ **SIN:**

Address: _____

Day 1:

On the _____ day of the _____ month in the year of 2015 I participant complete a total of _____ hours.

Day 2:

On the _____ day of the _____ month in the year of 2015 I participated in a total of _____ hours.

Total

In total, the participant completed a total of _____ hours and will be compensated with \$15.00 per hour for a total amount of \$____.____.



CONSENT TO PARTICIPATE IN RESEARCH

Title of Study: Ergonomic Evaluation for Right Angle Power Tools: Physical Demands Comparison of Three Direct-Current Tightening Strategies.

You are asked to participate in a research study conducted by **Dr. Joel Cort**, from the **Department of Human Kinetics** at the University of Windsor

If you have any questions or concerns about the research, please feel to contact **Dr. Joel Cort** at (519) 253-3000 ext. 4980 (joel.cort@uwindsor.ca), **Christian Steingraber** (steingr@uwindsor.ca) or **Danielle DeVries** (devriesd@uwindsor.ca) at 519-253-3000 ext. 4277.

PURPOSE OF THE STUDY

The United States Council for Automotive Research (USCAR) has determined repetitive strain and sustained handling of tools at various heights can lead to an increased risk of acute and chronic work related injuries in automotive manufacturing. The purpose of this study is to parameterize and quantify ergonomic factors (end-reaction torque and handle displacement) associated with right angle power tool usage in order to reduce work related musculoskeletal disorders and improve worker safety.

PROCEDURES

Subjects will be recruited from 3 age groups (18-29, 30-45, 45+ years) with 6 males and 6 females from all groups for a total of 36 participants. Subjects will then be randomly assigned within their age group to one of two joint types (Hard or Soft).

Procedures

- Information such as age, height, weight and hand dominance will first be collected. You will be given a period of 15 minutes to familiarize yourself with all tools, locations, and joint orientations. Following familiarization, the investigator will attach 16 electrodes (these measure the electrical activity of the muscles) and 52 motion-capture markers (these will help track your movements) to your skin and clothes.
- *Protocol*
 - **Maximal exertions-** participants will perform maximum exertions for forward flexion, shoulder elevation, forearm extension and wrist flexion to capture the muscle activity of the 16 muscles in the chest, back, shoulders and arms being studied.
Each of these contractions will last 2-3 seconds—you will be given a 60 second rest between contractions
 - **Positioning:** You will be placed in a predefined foot position and hold the right angle power tool with the right hand on the trigger and left hand on the identified stabilizing handle. You will place the tool spindle head on the joint simulator to perform the task.
 - **Testing Days:** You will complete 18 conditions per day, on 2 separate days, resulting in a total of 36 conditions. Each condition will consist of a randomized power tool tightening strategy, target torque and fastener location-orientation. You will complete 5 sets per condition, with a single set consisting of 5 joint tightening's in a 60 second period, resulting in a total of 5 minutes of continuous work per condition. You will receive a rest period of 2 minutes between each condition and will be asked to provide ratings of perceived exertion/effort based on a 10-point Borg scale.
- *Rest Days*
 - A minimum of 3 days rest will be provided between testing day 1 and testing day 2.

POTENTIAL RISKS AND DISCOMFORTS

Minimal risks are anticipated – the tasks that will be simulated are exactly as they are done within the working environment. The following are possible consequences associated with this experiment:

Muscle fatigue/soreness – as with any physical activity, there is a risk of the development of muscular fatigue or soreness. The exposure to the postures required to replicate the workplace tasks and the added weight from the right angle power-tool may cause transient muscle soreness/discomfort. Any muscle soreness or discomfort that may occur will ordinarily subside within a few days after testing.

Muscle and joint injury – with any exertions there is always a risk of muscle or joint injury. However, these exertions do not differ from those performed in the workplace.

Skin irritation – the electrodes used to record muscle activation, as well as the tabs used to affix the reflective markers associated with the motion capture system, are adhered directly to the skin. As such, there is risk of skin irritation. The irritation is similar to that which may develop from the use of commercially available bandages and will disappear within 2-3 days after testing.

POTENTIAL BENEFITS TO PARTICIPANTS AND/OR TO SOCIETY

Participants will be exposed to occupational biomechanics research practices which can benefit their awareness of personal ergonomics in activities of daily living. Furthermore, participants will experience the collection procedures of both electromyography and kinematics (Motion Analysis System) which may be useful in future academics and/or careers.

COMPENSATION FOR PARTICIPATION

Participants will be compensated with an hourly fee of \$15.00 per hour as well as receiving a University of Windsor, Faculty of Human Kinetics research t-shirt for your participation in this study.

CONFIDENTIALITY

Any information that is obtained in connection with this study and that can be identified to you will remain confidential and will be disclosed only with your permission. However, due to the nature of the study, you will not be able to remain anonymous to the investigators, but all electronic or hard copy data and personal information will be treated as confidential and a coding system will be employed to ensure confidentiality to others. Only the involved investigators will be familiar with the coding system.

All digital data will be stored on a password protected computer. All paper documentation will be secured in a locked filing cabinet, which will be placed in the locked office in the University of Windsor Human Kinetics building. Upon completion of the study, the digital data will be transferred to a hard disk, and the paper documents will be securely locked within the office of Dr. Joel Cort. One year past the completion of the study, the paper documents containing personal data will be shredded and disposed.

PARTICIPATION AND WITHDRAWAL

You are being invited to volunteer in this study. If you choose to volunteer, you are free to withdraw from the study without any consequence at any time either before or during the testing sessions. If you choose to withdraw, all of your digital data will be permanently deleted from the computers and all paperwork will be shredded.

FEEDBACK OF THE RESULTS OF THIS STUDY TO THE PARTICIPANTS

Research findings will be posted online on the University of Windsor Research Ethics Board website (www.uwindsor.ca/reb) upon the completion on this study. You will be contacted via email to be informed when this is available. This website is accessible to the public. Results are expected to be posted during the Fall of 2015.

SUBSEQUENT USE OF DATA

These data may be used in subsequent studies, in publications and in presentations.

RIGHTS OF RESEARCH PARTICIPANTS

If you have questions regarding your rights as a research participant, contact: Research Ethics Coordinator, University of Windsor, Windsor, Ontario, N9B 3P4; Telephone: 519-253-3000, ext. 3948; e-mail: ethics@uwindsor.ca

SIGNATURE OF RESEARCH PARTICIPANT/LEGAL REPRESENTATIVE

I understand the information provided for the study **Ergonomic Evaluation for Right Angle Power Tools: Physical Demands Comparison of Three Direct-Current Tightening Strategies** as described herein. My questions have been answered to my satisfaction, and I agree to participate in this study. I have been given a copy of this form.

Name of Participant

Signature of Participant

Date

SIGNATURE OF INVESTIGATOR

These are the terms under which I will conduct research.

Signature of Investigator

Date

Signature of Investigator

Date

APPENDIX C

RAPT PHYSICAL DEMANDS DATA COLLECTION SHEETS

MoCap

Participant ID: _____

Date: _____

Experimental Group: **HARD** or **SOFT**
1 or **2**

Collection Day: _____

Subject Name: _____

Age: _____

Subject Height: _____

Subject Weight: _____

Subject _____

Handedness: L or R

| Calibration: Tools, Joints, MoCap | | | | | |
|-----------------------------------|---------|-------------|----|-----------|----------|
| Consent Form & Questionnaire | | | | | |
| 15 min. Familiarization | | | | | |
| MVC (6 exercises) | | | | | |
| Bias Trial | | | | | |
| Markers & T-Pose & ROM | | | | | |
| Trial # | Posture | TS | TT | Condition | Comments |
| 1 | 1 | TS | 55 | 5 | |
| 2 | 2 | TS w/ SS | 30 | 16 | |
| 3 | 1 | TT | 70 | 3 | |
| 4 | 1 | TS w/ SS | 55 | 8 | |
| 5 | 1 | TT | 30 | 1 | |
| 6 | 2 | TS w/ SS | 70 | 18 | |
| 7 | 4 | TS | 30 | 31 | |
| 8 | 4 | TS w/ SS | 70 | 36 | |
| 9 | 1 | TT | 55 | 2 | |
| 10 | 2 | TS w/ SS | 55 | 17 | |
| 11 | 3 | TT | 70 | 21 | |
| 12 | 2 | TS | 30 | 13 | |
| 13 | 4 | TS | 70 | 33 | |
| 14 | 2 | TS | 55 | 14 | |
| 15 | 1 | TS w/ SS | 70 | 9 | |
| 16 | 3 | TS w/ SS | 55 | 26 | |
| 17 | 1 | TS w/ SS | 30 | 7 | |
| 18 | 3 | TS | 30 | 22 | |

Scrap Trials:

RAPT Physical Demands Data Collection Sheets

MoCap

Participant ID:

Date:

Experimental Group: **HARD** or **SOFT**

Collection Day:

1 or 2

Subject Name: _____

Age: _____

Subject Height: _____

Subject Weight: _____

Subject

Handedness: L or R

| Calibration: Tools, Joints, MoCap | | | | | |
|-----------------------------------|---------|-------------|----|-----------|----------|
| Consent Form & Questionnaire | | | | | |
| 15 min. Familiarization | | | | | |
| MVC (6 exercises) | | | | | |
| Bias Trial | | | | | |
| Markers & T-Pose & ROM | | | | | |
| Trial # | Posture | TS | TT | Condition | Comments |
| 1 | 4 | TS | 55 | 32 | |
| 2 | 1 | TS | 30 | 4 | |
| 3 | 3 | TS w/ SS | 30 | 25 | |
| 4 | 3 | TS | 70 | 24 | |
| 5 | 3 | TT | 30 | 19 | |
| 6 | 3 | TS | 55 | 23 | |
| 7 | 1 | TS | 70 | 6 | |
| 8 | 4 | TT | 30 | 28 | |
| 9 | 4 | TT | 70 | 30 | |
| 10 | 2 | TS | 70 | 15 | |
| 11 | 4 | TS w/ SS | 55 | 35 | |
| 12 | 4 | TS w/ SS | 30 | 34 | |
| 13 | 4 | TT | 55 | 29 | |
| 14 | 2 | TT | 70 | 12 | |
| 15 | 2 | TT | 55 | 11 | |
| 16 | 2 | TT | 30 | 10 | |
| 17 | 3 | TS w/ SS | 70 | 27 | |
| 18 | 3 | TT | 55 | 20 | |

Scrap Trials

APPENDIX D

Questionnaire used for identification of preexisting musculoskeletal disorders.

Mine: _____
 Initial of first name: __ Initial of last name: __ Last 4 digits of social security number: _____ Immediate Supervisor: _____ Date: __/__/__
 Job Title: _____ Section: _____ Gender: M F Age: _____ Height: ___ ft. ___ in. Weight: _____
 How long have you been doing this job? ___ years ___ months On average, how many hours do you work each week? _____

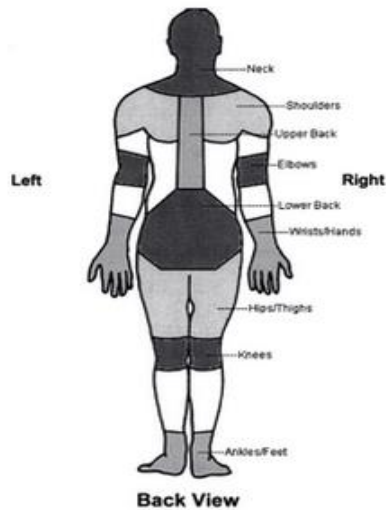

| To be answered by everyone | To be answered by those who have had trouble | |
|---|---|--|
| Have you at any time during the last 12 months had trouble (ache, pain, discomfort, numbness) in: | Have you at any time during the last 12 months been prevented from doing your normal work (at home or away from home) because of the trouble? | Have you had trouble at any time during the last 7 days? |
| Neck <input type="checkbox"/> No <input type="checkbox"/> Yes | <input type="checkbox"/> No <input type="checkbox"/> Yes | <input type="checkbox"/> No <input type="checkbox"/> Yes |
| Shoulders <input type="checkbox"/> No <input type="checkbox"/> Yes, right shoulder <input type="checkbox"/> Yes, left shoulder <input type="checkbox"/> Yes, both shoulders | <input type="checkbox"/> No <input type="checkbox"/> Yes | <input type="checkbox"/> No <input type="checkbox"/> Yes |
| Elbows <input type="checkbox"/> No <input type="checkbox"/> Yes, right elbow <input type="checkbox"/> Yes, left elbow <input type="checkbox"/> Yes, both elbows | <input type="checkbox"/> No <input type="checkbox"/> Yes | <input type="checkbox"/> No <input type="checkbox"/> Yes |
| Wrists/Hands <input type="checkbox"/> No <input type="checkbox"/> Yes, right wrist/hand <input type="checkbox"/> Yes, left wrist/hand <input type="checkbox"/> Yes, both wrists/hands | <input type="checkbox"/> No <input type="checkbox"/> Yes | <input type="checkbox"/> No <input type="checkbox"/> Yes |
| Upper Back <input type="checkbox"/> No <input type="checkbox"/> Yes | <input type="checkbox"/> No <input type="checkbox"/> Yes | <input type="checkbox"/> No <input type="checkbox"/> Yes |
| Lower Back (small of back) <input type="checkbox"/> No <input type="checkbox"/> Yes | <input type="checkbox"/> No <input type="checkbox"/> Yes | <input type="checkbox"/> No <input type="checkbox"/> Yes |
| One or Both Hips/Thighs <input type="checkbox"/> No <input type="checkbox"/> Yes | <input type="checkbox"/> No <input type="checkbox"/> Yes | <input type="checkbox"/> No <input type="checkbox"/> Yes |
| One or Both Knees <input type="checkbox"/> No <input type="checkbox"/> Yes | <input type="checkbox"/> No <input type="checkbox"/> Yes | <input type="checkbox"/> No <input type="checkbox"/> Yes |
| One or Both Ankles/Feet <input type="checkbox"/> No <input type="checkbox"/> Yes | <input type="checkbox"/> No <input type="checkbox"/> Yes | <input type="checkbox"/> No <input type="checkbox"/> Yes |

*Based on the Nordic Questionnaire

Modified Nordic MSD Questionnaire used to determine musculoskeletal injury (Wiehage & Turin, 2004)

APPENDIX E

PLACEMENT AND LOCATION OF MOTION CAPTURE MARKERS

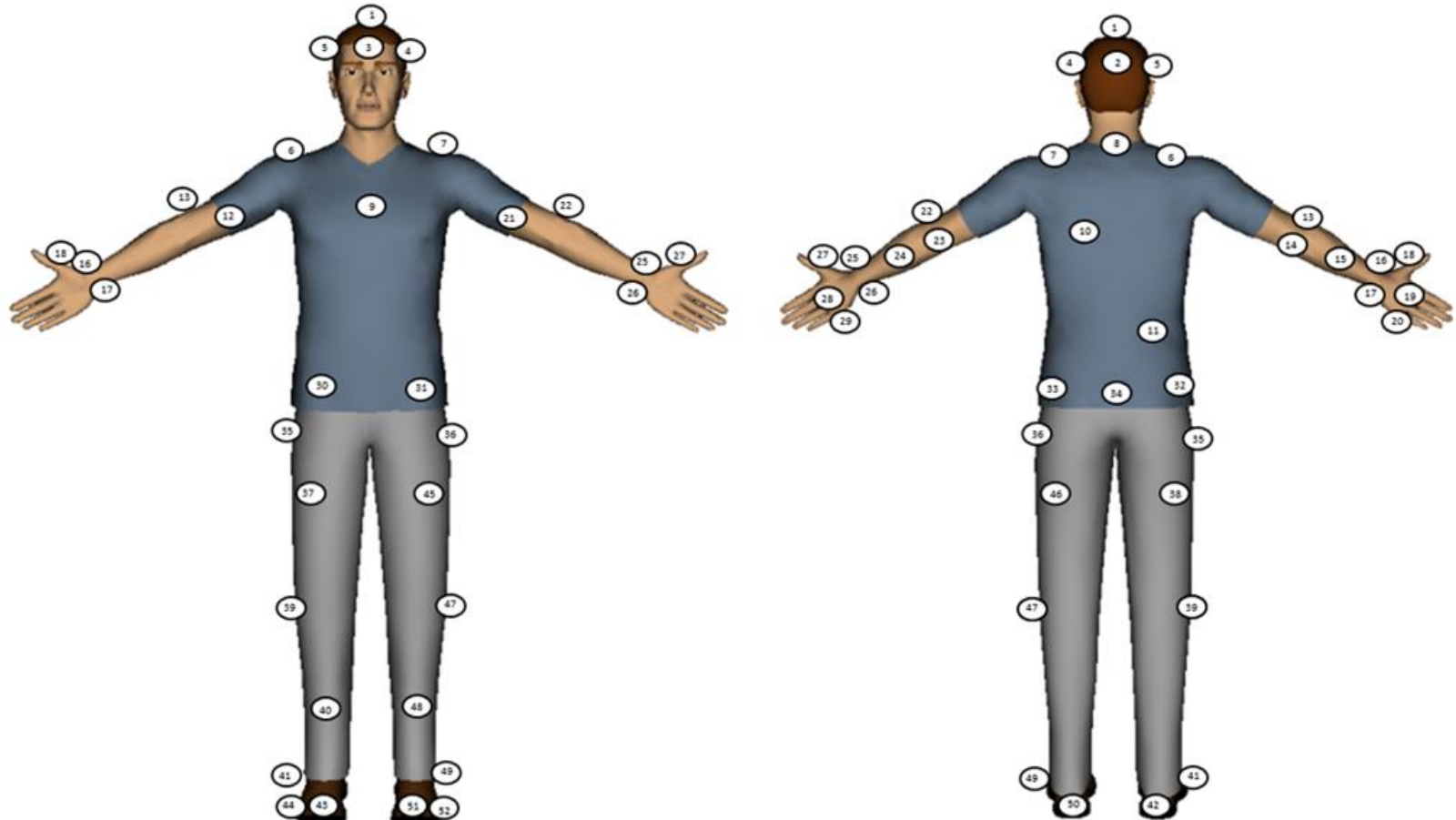

| Marker Placements | Location |
|--------------------------|---|
| 1 | Top center of head |
| 2 | Mid-back of head |
| 3 | Middle of forehead |
| 4 | Left side of head, above ear |
| 5 | Right-back corner of head |
| 6 | Top of shoulder, midway between neck and acromion process |
| 7 | Top of shoulder, midway between neck and acromion process |
| 8 | Back of neck, above T1 |
| 9 | Middle of sternum |
| 10 | Upper-left side of back on scapular (approx. T5 |
| 11 | Right-mid back (Approx. L1) |
| 12 | Midway along long axis of humerus, top of bicep, lateral offset |
| 13 | Lateral side of elbow joint over the joint center |
| 14 | Distal end of the humerus behind the elbow |
| 15 | Midway along long axis of forearm on flat posterior surface |
| 16 | Lateral side of wrist over the radial styloid process |
| 17 | Medial side of wrist over the ulnar styloid process |
| 18 | Posterior side of hand, distal end of the 1st metacarpal |
| 19 | Posterior side of hand, middle of the 3rd metacarpal |
| 20 | Posterior side of hand, distal end of the 5th metacarpal |
| 21 | Midway along long axis of humerus, top of bicep, lateral offset |
| 22 | Lateral side of elbow joint over the joint center |
| 23 | Distal end of the humerus behind the elbow |
| 24 | Midway along long axis of forearm on flat posterior surface |
| 25 | Lateral side of wrist over the radial styloid process |
| 26 | Medial side of wrist over the ulnar styloid process |
| 27 | Posterior side of hand, distal end of the 1st metacarpal |
| 28 | Posterior side of hand, middle of the 3rd metacarpal |
| 29 | Posterior side of hand, distal end of the 5th metacarpal |
| 30 | On right ASIS |
| 31 | On left ASIS |
| 32 | On right PSIS |
| 33 | On left PSIS |
| 34 | Mid-back, top of sacrum |
| 35 | Right, lateral side of pelvis near greater trochanter |
| 36 | Left, lateral side of pelvis near greater trochanter |
| 37 | Antero-lateral of thigh 1/3 along length of femur |
| 38 | Postero-lateral of area thigh 1/3 along length of femur |

| | |
|----|---|
| 39 | Lateral side of knee, approximately over the joint center |
| 40 | Anterior side of lower leg, midway along its length |
| 41 | On the lateral malleolus of the right fibula |
| 42 | On the posterior side of the heel |
| 43 | On the head of the 3rd metatarsal |
| 44 | Lateral side of 5th metatarsal, midway along its length |
| 45 | Antero-lateral of area thigh 1/3 along length of femur |
| 46 | Postero-lateral of area thigh 1/3 along length of femur |
| 47 | Lateral side of knee, approximately over the joint center |
| 48 | Antero side of lower leg, midway along its length |
| 49 | On the lateral malleolus of the left fibula |
| 50 | On the posterior side of the heel |
| 51 | On the head of the 3rd metatarsal |
| 52 | Lateral side of 5th metatarsal, midway along its length |

VITA AUCTORIS

NAME: Christian Steingraber

PLACE OF BIRTH: Oregon, OH

YEAR OF BIRTH: 1989

EDUCATION: University of Windsor, B.H.K, Windsor, ON,
2013

University of Windsor, M.H.K, Windsor, ON,
2017