

Title	Graph-based Joint Source Channel LDPC Decoding for Cooperative Communication with Error-corrupted Relay Observations
Author(s)	Abdessalem, Marwa Ben; Zribi, Amin; Matsumoto, Tad; Bouallègue, Ammar
Citation	2017 13th International Wireless Communications and Mobile Computing Conference (IWCMC): 1588-1593
Issue Date	2017
Type	Conference Paper
Text version	author
URL	http://hdl.handle.net/10119/14714
Rights	This is the author's version of the work. Copyright (C) 2017 IEEE. 2017 13th International Wireless Communications and Mobile Computing Conference (IWCMC), 2017, 1588-1593. Personal use of this material is permitted. Permission from IEEE must be obtained for all other uses, in any current or future media, including reprinting/republishing this material for advertising or promotional purposes, creating new collective works, for resale or redistribution to servers or lists, or reuse of any copyrighted component of this work in other works.
Description	



Graph-based Joint Source Channel LDPC Decoding for Cooperative Communication with Error-corrupted Relay Observations

Marwa Ben Abdesslem*, Amin Zribi*[†], Tad Matsumoto[‡], and Ammar Bouallègue*

*University of Tunis El Manar, National Engineering School of Tunis, SysCom labs, BP 37, Le Belvedere, 1002, Tunis
Email: marwabenabdesslem@yahoo.fr, amin.zribi@isetcom.tn, ammarbouallegue.syscom@gmail.com

[†] Institut Télécom, Télécom Bretagne, Lab-STICC UMR CNRS 6285, Technopole Brest Iroise, CS 83818, Brest, France

[‡]Japan Advanced Institute of Science and Technology, 1-1 Asahidai, Nomi, Ishikawa, Japan,
and Centre for Wireless Communications (CWC), University of Oulu, Finland (Part-time)

Email: matumoto@jaist.ac.jp

Abstract—In this paper, we design a unified framework decoder for relay systems with iterative decoding. In the proposed scheme, the source node needs to transmit a correlated content to a destination with the help of a relay. Then, a distributed Joint Source Channel (JSC) Low-Density-Parity-Check (LDPC) encoding is applied at the source and the relay. The destination receives simultaneously the source compressed data from the source node, and the source/channel encoded data from the relay node. The cooperative network is mapped into a factor graph on which message passing iterative decoding is applied to estimate the source information. The JSC decoder takes into account the source-relay correlation which involves remarkable improvements even if errors occur at the source-relay link. The Bit Error-Rate (BER) system performance are investigated for different scenario, according to the relay position, and it is shown that the performance of the proposed cooperative scheme is typically about 0.5-1.0 dB better than an equivalent rate point-to-point system.

I. INTRODUCTION

Shannon's source and channel separation theorem was demonstrated for communication systems with infinite complexity and infinite-block length codes, which are transmitted over ergodic channels without loss of optimality [1], [2]. Although, for practical systems, there are always limits on the complexity and the delay, and the channels are not constantly ergodic, therefore, the separation theorem may not be applied. Hence, jointly optimizing source and channel coding emerged as an interesting practical solution.

In this framework, the main question was how to exploit the source redundancy, or the residual redundancy after source compression to improve the system error correction performance. First solutions focused on channel decoding exploiting source information. Then, with the development of the turbo decoding concept, iterative JSC decoding methods were proposed to improve the system performance against the channel noise. The main advantage was that both source and channel decoders can mutually exchange information. First, researchers considered entropy encoding techniques (variable length codes, arithmetic codes) for source coding and applied iterative decoding that exploits the residual redundancy

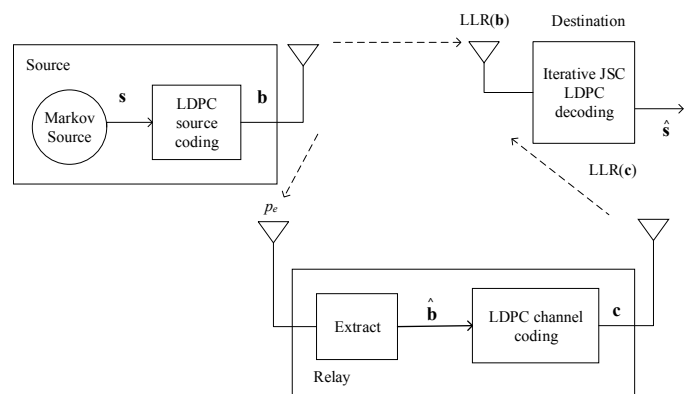

Fig. 1. The proposed cooperative communication scheme with distributed joint source and channel LDPC coding in the source and the relay respectively.

as in [3]–[6], [11]. Remarkable improvements were demonstrated, however, it was shown that the variable-length entropy-achieving codes deliver a compressed bitstream which is very sensitive to transmission errors. Such a property is not suitable when multi-hop lossy forwarding networks are considered, where the error will also propagate through the network nodes. Many other contributions treated the case where source compression cannot be applied for power or computational constraints. They mainly focused on exploiting the source correlation at the decoder [7]–[9]. Even efficient, such solutions are not reasonable for bandwidth restricted systems as many practical wireless applications. Motivated by the Low-Density-Parity-Check (LDPC) codes error-correction efficiency [10], M. Fresia *et al.* proposed recently [11] a fixed-to-fixed JSC LDPC coding scheme for correlated sources. The structure of the JSC coding is provided by a fixed length source encoder equivalent to an LDPC code that compresses the redundant source, followed by a conventional error-correcting LDPC code that protects the compressed sequence against channel errors. The double JSC LDPC code can also be represented by a bipartite Tanner graph combining the source and channel

elementary graphs. Then, the decoding process applies the Belief Propagation (BP) algorithm. It was demonstrated that the double LDPC coding enables remarkable gains compared to classical LDPC coding, at the expense of a residual error floor depending on the source and channel coding rates, and on the source correlation [12]. In the present paper, we propose a first solution where we integrate the double LDPC joint source-channel coding solution into a cooperative communication setup, where the relay observes error-corrupted information.

By exploiting the broadcast nature of the wireless channel, cooperative communication allows single-antenna radios to share their antennas to form a virtual antenna array, and offers significant performance enhancements. The cooperative system can be composed of a source, a destination and one/many relays that aim at helping the source to deliver efficiently his information. According to the operation made at the relay, different strategies can be defined like Amplify-and-Forward (AF) [13], [14], Decode-and-Forward (DF) [15], Compress-and-Forward (CF) [16], and Coded Cooperation (CC) [17]. Many authors focused on the achievable information rates and the capacity of the relay channel [16], [18]. Other researchers focused on developing practical transmission schemes for the relay cooperative system to reach the previously specified theoretical bounds by using turbo-based iterative decoding methods. In [19], authors considered a distributed turbo code where the two elementary recursive systematic convolutional codes are separated between the source and the relay. A turbo-based coding scheme for cooperative communications was designed with the corresponding iterative decoding algorithm in [20] for the full-duplex relay setup. Motivated by the LDPC capacity-achieving performance, in [21]–[27], the authors proposed cooperative schemes using LDPC codes and graph-based iterative decoding. In [21], authors considered two variations of DF strategy at the relay and showed that relaying allows remarkable improvements compared to direct link communications. LDPC codes with iterative decoding on the block-fading relay channels were also studied in [22] where authors considered two users that employ coded cooperation. Designing efficient irregular LDPC codes based on density evolution together with a Gaussian approximation for the coded cooperative scheme was a focus of many researchers like [23] and [24]. Network coding was also considered in many LDPC-based cooperative communication systems [25]–[27] due to its ability to improve network throughput and enhance network robustness. Mainly treated by physical layer researchers, few cooperative communication solutions focused on source coding, which is a mandatory component of correlated data transmission and bandwidth limited systems. Cooperative source-channel coding schemes that exploit the wireless channel and the correlation between different sources was proposed in [28] based on low-density generator matrix codes. Also, in [29] authors proposed a distributed JSC decoding structure that exploits the source memory structure and the source-relay correlation in a one-way relay system. At the receiver, a modified version of the Bahl, Cocke,

Jelinek and BCJR algorithm is used to exploit the source-relay correlation and the memory structure of the source. In [30], authors proposed a turbo product code distributed between many sources and a relay, where the source temporal and spatial correlations are exploited at the iterative decoding stage. Remarkable improvements were demonstrated in [28]–[30], however, no source compression is applied, which make their application to bandwidth-constrained wireless networks hard.

To this end, in this paper, we focus on correlated source transmission over a cooperative system where data compression is applied. We propose to use a distributed JSC LDPC code, where LDPC source coding is made at the source node based on a matrix operation, and LDPC channel coding is applied at the relay that forwards the corresponding codeword to the destination through a noisy channel. We present a general network decoder that aims at exploiting the residual source correlation and the source-relay correlations to deliver the best estimate of the source sequence. The contribution of this paper is two-fold: first, we propose a distributed source channel coding strategy for cooperative communication based on JSC LDPC codes. Second, a unified framework with iterative decoding is proposed for the overall network, and also takes into account the case of error-corrupted observations at the relay. The proposed system performance is investigated under three different scenarios according to the relay position, and for different source-relay link error probabilities.

The rest of the paper is structured as follows. In Section II, we present the system model and notations. The iterative decoding scheme with correlation exploitation is presented in Section III. Simulation results and discussions are illustrated in Section IV. Finally, Section V gives some concluding remarks.

II. SYSTEM MODEL AND NOTATIONS

In this paper, we assume that the relay channel operates in a time-division duplex mode, where in a first time slot, the source broadcasts to the relay and destination, while in the second slot, just the relay transmits to the destination. The proposed cooperative communication setup aims at delivering a correlated content through noisy channels. Hence, involves source and channel coding operations that will be distributed between the source and the relay respectively. As previously mentioned, JSC LDPC codes will be considered for both compression and error protection which allows the mapping of the whole network into a factor graph.

We assume that the source generates correlated sequences \mathbf{s} with n symbols length. The source memory is described by a two-state binary first-order Markov model (S_t), which is defined by the transition probabilities α and β , respectively given by $\alpha = \Pr(S_t = 1 | S_{t-1} = 0)$ and $\beta = \Pr(S_t = 0 | S_{t-1} = 1)$. The entropy rate of the stationary binary Markov source is $H(S) = \mu_0 h(\alpha) + \mu_1 h(\beta)$, where $h(x) = -x \log_2(x) - (1-x) \log_2(1-x)$, μ_0 and μ_1 are respectively the states 0 and 1 stationary probabilities. As first proposed in [11], the JSC LDPC code makes matrix operations for both source and channel coding. The first component aims

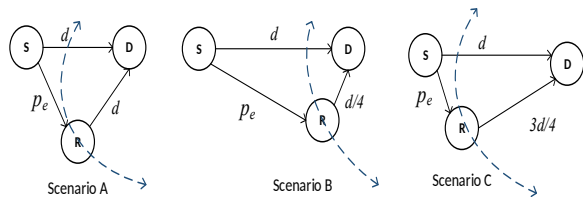

Fig. 2. Three relay location scenarios of the cooperative communication system.

at compressing the correlated source by mean of a parity check matrix \mathbf{H}_{sc} with dimensions $(l \times n)$. Then, source coding is made as $\mathbf{b} = \mathbf{H}_{sc} \times \mathbf{s}$, where \mathbf{b} is the column vector representing the l bits compressed sequence, and \mathbf{s} is the source symbol sequence. The compression rate is defined by $R_s = l/n$. The second LDPC code aims at protecting the compressed data as conventional linear block coding do, and we have $\mathbf{c} = \mathbf{G}_{cc}^T \times \mathbf{b} = \mathbf{G}_{cc}^T \times \mathbf{H}_{sc} \times \mathbf{s}$, where \mathbf{G}_{cc}^T is the channel coding generator matrix with dimensions $(l \times m)$, and \mathbf{c} is the m -bits length codeword to be transmitted. Also, we define \mathbf{H}_{cc} as the channel code parity check matrix with dimensions $((m-l) \times m)$. The channel coding rate is defined by $R_c = l/m$. Notice that, for JSC LDPC code, the overall rate is equal to $R = n/m$. In the case of point-to-point communication, the JSC LDPC code performance showed [11], [12] substantial improvements in the low-to-medium signal-to-noise ratio (SNR) compared to an equivalent rate LDPC channel coding scheme. The gain improvement is at the expense of a performance error floor at high SNR, which depends on the source correlation degree and the LDPC source coding rate.

In this paper, we propose a relay-based cooperative system where the JSC LDPC compression and error protection operations are distributed in the source and the relay respectively. As shown in Fig. 1, the system is composed of a single relay, one source, and one destination with two transmission phases. First, the source generates correlated data, which are compressed by the LDPC source encoder, then modulated using Binary-Phase Shift Keying (BPSK) and transmitted directly to the destination and to the relay through separated noisy channels. During the second phase, the relay extracts the compressed sequence, denoted \mathbf{b} , that will be encoded by the LDPC channel code. In the same way, the obtained codeword is modulated then transmitted to the destination over an Additive White Gaussian Noise (AWGN) channel. At the receiver, the destination extracts the original information using an iterative decoding algorithm that is described in the following.

It is known that cooperative communication system performance mainly depends on the relay position with respect to the source and the destination. Then, we consider three relay location scenarios (scenario A, scenario B, scenario C), which are described in Fig. 2. We express by d_{SD} and d_{RD} the distance from the source S to the destination D and from the relay R to the destination D , respectively. We denote by G_{RD}

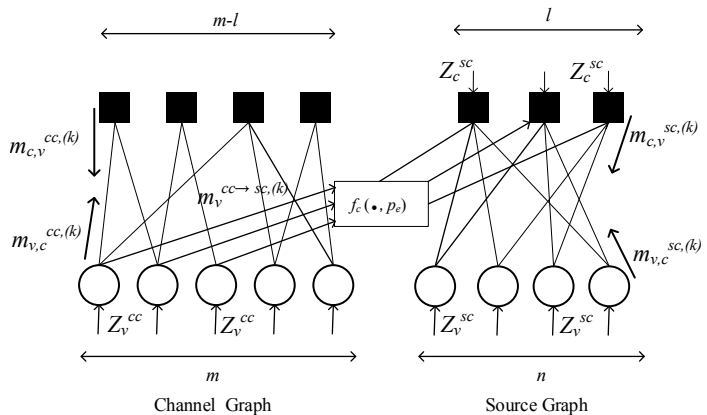

Fig. 3. Message passing decoding algorithm for distributed JSC LDPC coding exploiting source-relay correlation.

the relative gain of the link between R and D with respect to the source-destination link given by $G_{RD} = (\frac{d_{SD}}{d_{RD}})^n$, where n is the path-loss exponent. In this paper, we consider $n = 3.52$ [31] and we assume that the source-destination link has a normalized gain. In scenario A, we consider a network where the distance between the source and destination is the same as the distance between the relay and the destination, thus equivalent SNRs, $SNR_{SD} = SNR_{RD}$. In scenario B, we assume the relay to be closer to the destination than the source ($d_{RD} = \frac{d_{SD}}{4}$), and $G_{RD} = (\frac{d_{SD}}{d_{RD}})^n = (\frac{d}{d/4})^{3.52} = 21.19$ dB. Therefore, $SNR_{RD} = SNR_{SD} + 21.19$ dB. Scenario C supposes that the relay is located closer to the source than the destination ($d_{RD} = \frac{3d_{SD}}{4}$), where $G_{RD} = (\frac{d}{3d/4})^{3.52} = 4.4$ dB, then the $SNR_{RD} = SNR_{SD} + 4.4$ dB. We notice that the source-relay link can be error corrupted with an error probability p_e depending on the SNR_{SR} . Hence, to analyse the error probability effect on the proposed system performance, we consider that the source-relay distance is varying while keeping the relay-destination, source-destination distance ratio the same according to the scenario.

III. THE ITERATIVE DECODING SCHEME WITH SOURCE-RELAY CORRELATION EXPLOITATION

In this paragraph, we describe the message-passing iterative decoding algorithm for the previously proposed cooperative communication system. In general, LDPC channel codes are represented by a Tanner graph mapped into two sets of nodes: variable nodes representing columns, and check nodes representing rows of the LDPC parity check matrix. The used LDPC source coding operation is similar to the LDPC channel coding, then can also be described by a Tanner graph. Hence, the JSC LDPC based cooperative network can be fully described by two concatenated graphs as shown in Fig. 3. We propose a cascade decoding method based on a modified Belief Propagation (BP) algorithm with message passing between variable nodes and check nodes of the component decoders.

For the cooperative communication system, the LDPC source and channel coding operations take place at the source and the relay respectively. Then, as depicted in Fig. 1, the

destination observes two information LLR(\mathbf{b}) and LLR(\mathbf{c}) coming from the source and the relay respectively. The aim of the destination decoder is to estimate the source information by exploiting the source-relay correlation. The receiver observes the noisy version of the codeword \mathbf{c} denoted $\mathbf{r} = (r_1, \dots, r_m)$ where $r_v = (1 - 2c_v) + n_v$, n_v is a random AWGN sample, and σ_{RD}^2 is the relay-destination channel noise variance. The corresponding bits' LLRs $Z_v^{cc} = LLR(\mathbf{c}_v) = \frac{2r_v}{\sigma_{RD}^2}$ are used to initialize the channel decoder variable nodes. The check nodes of the same graph are initialized to $m_{c,v}^{cc,(0)} = 0$ for $c = (1, \dots, m-l)$. Then, each variable node v informs the connected check nodes c , for every k iteration of BP with a message given by:

$$m_{v,c}^{cc,(k)} = Z_v^{cc} + \sum_{c' \neq c} m_{c',v}^{cc,(k-1)} \quad (1)$$

Thereafter, the check nodes c respond by their LLR constraints for each variable node v to which they are connected by

$$m_{c,v}^{cc,(k)} = 2 \tanh^{-1} \left(\prod_{v' \neq v} \tanh \left(\frac{m_{v',c}^{cc,(k)}}{2} \right) \right) \quad (2)$$

We note that the wireless source-relay link is assumed to be noisy, and the compressed sequence extracted by the relay as $\hat{\mathbf{b}}$ is corrupted by random errors with bit error probability p_e . The source-channel iterative decoder should take into account such error probability. Indeed, the LDPC channel decoder will deliver an estimate about the error-corrupted version of \mathbf{b} which is LLR($\hat{\mathbf{b}}$). To take this difference into consideration, we should apply an LLR updating function to compute LLR(\mathbf{b}) based on LLR($\hat{\mathbf{b}}$) and on the bit-error probability p_e , before applying LDPC source decoding. Based on the fact that $P(b_i = x) = P(\hat{b}_i = \bar{x})(1 - p_e) + P(\hat{b}_i = x)p_e$ where $x \in \{0, 1\}$ and $\bar{x} = 1 - x$, we can demonstrate that, for $i = (1, \dots, m)$, we have

$$LLR(b_i) = \log \left(\frac{\exp(LLR(\hat{b}_i))(1 - p_e) + p_e}{(1 - p_e) + \exp(LLR(\hat{b}_i))p_e} \right) \quad (3)$$

$$= f_c(LLR(\hat{b}_i), p_e) \quad (4)$$

Then, the LDPC iterative source decoding can take place. First, the receiver observes the noisy version of the vector \mathbf{b} with the corresponding LLRs denoted $Z_c^{sc} = LLR(\mathbf{b}_c) = \frac{2r_c}{\sigma_{SD}^2}$ for every check node $c = (1, \dots, l)$. Notice that for an AWGN channel, $r_c = (1 - 2b_c) + n_c$ is the received sample, n_c is the channel noise and σ_{SD}^2 is the source-destination channel noise variance. And, the variable nodes are initialized to $Z_v^{sc} = \log(\frac{1-p_v}{p_v})$, where $p_v = \Pr(s_v = 1)$ for $v = (1, \dots, n)$ is the *a priori* source probability. Second, for an iteration k , the messages delivered by a variable node v to a check node c are evaluated as:

$$m_{v,c}^{sc,(k)} = Z_v^{sc} + \sum_{c' \neq c} m_{c',v}^{sc,(k-1)} \quad (5)$$

For the same iteration, the check nodes c messages followed to a connected variable node v are given by

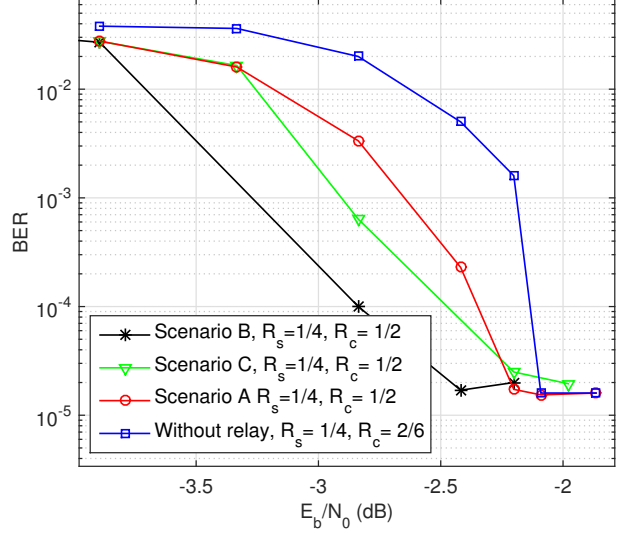

Fig. 4. BER performance for equivalent rates point-to-point and relay-based JSC LDPC systems in the case of error-free observations at the relay with three location scenarios.

$$m_{c,v}^{sc,(k)} = 2 \tanh^{-1} \left(\tanh \left(\frac{Z_c^{sc}}{2} \right) \prod_{v' \neq v} \tanh \left(\frac{m_{v',c}^{sc,(k)}}{2} \right) \times \tanh \left(\frac{f_c(m_v^{cc \rightarrow sc}, p_e)}{2} \right) \right) \quad (6)$$

where $m_v^{cc \rightarrow sc}$ is the information delivered by the LDPC channel decoder given by

$$m_v^{cc \rightarrow sc} = Z_v^{cc} + \sum_{c'} m_{c',v}^{cc,(I_c)} \quad (7)$$

I_c is the maximum number of iterations of the LDPC channel decoding. After I_s iterations of the decoding process, the source bits *a posteriori* LLRs are estimated according to $LLR(\mathbf{s}_v) = Z_v^{sc} + \sum_c m_{c,v}^{sc,(I_s)}$

IV. SIMULATION RESULTS

In this section, we study the advantage of using the JSC LDPC coding for a cooperative communication setup, and we compare the performance with respect to the JSC encoding based on LDPC codes for point-to-point system, with and without errors in the source-relay link, and with three relay location scenarios (scenario A, scenario B and scenario C) previously described in Section II.

A. Cooperative communication using JSC LDPC coding and noiseless source-relay link

We study the cooperative communication system presented in Section II with distributed JSC LDPC coding in the source and the relay. We assume that the wireless link from the source to the relay is noiseless. We consider regular LDPC codes. The objective is to compare the performance of JSC for cooperative

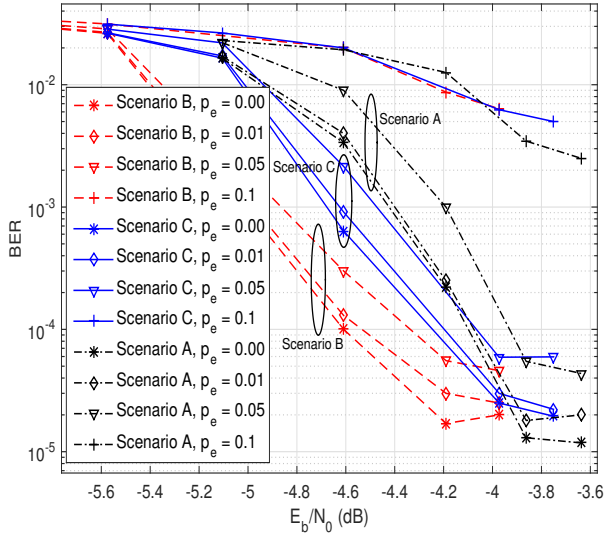

Fig. 5. BER performance for the relay-based JSC LDPC system with different error-probabilities at the relay and for the three relay location scenarios

communication with an equivalent rate point-to-point system using JSC LDPC with different locations of the relay, which are described above. At the decoder side, we consider the cascade decoder using BP with $I_s = I_c = 100$ iterations.

In Fig. 4, we plot the BER as a function of E_b/N_0 for a Markov source with two states and 3000 bits length, in which the probability of switching states is equal to 0.02. The performance are analyzed in the waterfall and error floor regions for a point-to-point system with $R_c = 1/3$ and $R_s = 1/4$, and a relay system with $R_s = 1/4$ and $R_c = 1/2$. Since the relay system, induces an extra transmission phase, the two systems result in the same overall transmission rate of 1.33. We observe that the performance of the cooperative scheme in the waterfall region is better than the JSC LDPC based point-to-point system with different relay scenarios. We provide a gain of about 0.5 dB for BER equal to 10^{-3} , and a gain of about 0.6 dB for a BER equal to 10^{-2} with scenario A. Also, we provide a gain of about 0.65 dB for a BER equal to 10^{-2} with scenario C, and a gain of about 1 dB with scenario B. The BER is reduced at the expense of an error floor of almost $2 \cdot 10^{-5}$. We can notice that the error floor is almost the same for both cooperative communication and point-to-point systems, because they have the same compression rate. The latter is a result of residual decoding errors introduced by the fixed-to-fixed source code. We note that the performance of the cooperative communication system is better in the waterfall region when the relay is closer to the destination than the source (scenario B), than the other scenarios (A and C). We provide a gain of about 0.35 dB for a BER = 10^{-3} compared to scenario C, and a gain of about 0.6 dB compared to scenario A. We conclude that the cooperative communication system using a relay can improve the system performance for a noiseless relay observations, especially with scenario B.

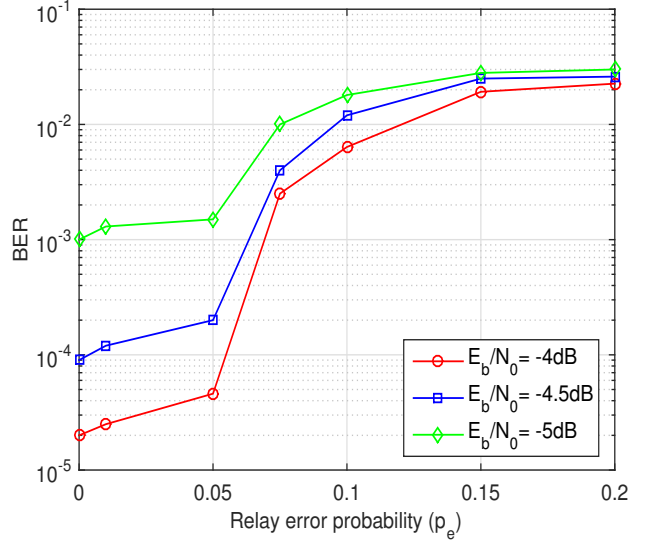

Fig. 6. BER performance for the relay-based cooperative system with scenario B versus different error-probabilities.

B. Cooperative communication using JSC LDPC coding and noisy source-relay link

In this section, we keep the same cooperative communication system presented above with the three relay location scenarios. However, we assume that the wireless link between source and relay is noisy. The objective behind this simulation is to show the effect of the source-relay link error probability on the cooperative communication system. We consider a JSC LDPC coding using two concatenated LDPC codes with rates $R_s = 1/4$ and $R_c = 1/2$ for the source and the channel respectively, which indicate an overall transmission rate of 1.33. We plot the BER as a function of E_b/N_0 in Fig. 5 for a Markov source with $\alpha = \beta = 0.02$ and different error probabilities.

Through these different relay scenarios, we can distinguish that the performance of the cooperative system with scenario B in the waterfall region is the best and the scenario A is the worst. We can observe that with the same error probability $p_e = 0.01$ at the relay, we provide a gain of about 0.6 dB for BER= 10^{-3} with scenario B comparing with the performance of a cooperative scheme with scenario A, and a gain of about 0.4 with the scenario C. Also, we can remark that the error floor is the same for the three relay scenarios for a given relay error probability p_e . We observe that with high error probability of $p_e = 0.1$ at the relay, the performance of the cooperative communication system with the three relay positions can be damaged in both the error floor and waterfall regions. We almost loose 0.85 dB for a BER= 10^{-2} with the scenario A, 0.75 dB with scenario C and 0.95 dB for a BER= 10^{-2} with the scenario B.

For relatively medium-to-low error probabilities, we keep almost the same system performance as the error-free case. In fact, for $p_e = 0.05$ a loss of 0.15 dB is obtained in

the waterfall region and the error floor is slightly increased from 2.10^{-5} to 4.10^{-5} with scenario A, and we loose 0.1 dB for a BER= 10^{-4} with scenario C. Due to the updating function combined with iterative decoding, the cooperative system remains robust against observation errors at the relay with a probability lower than 0.05.

In Fig. 6, we plot the BER as a function of p_e for cooperative communication system with the relay location best scenario B described above, where the source node broadcasts to both the relay and destination nodes, in the first phase. In the second phase, the relay extracts the signal which contains errors, encodes and transmits to the destination. For $E_b/N_0 = -4$ dB, -4.5 dB, and -5 dB, we showed that the performance of the cooperative communication system remains more robust even for an error probability less than 0.05.

V. CONCLUSIONS

In this paper, we presented a JSC coding and decoding scheme for cooperative communication with a correlated source, using LDPC codes. First, we presented the adopted system model where we distributed source and channel coding operations at the source and the relay nodes respectively. Then, we developed an iterative message passing decoder applied on the whole network factor graph. We demonstrated, based on simulation results, that the cooperative scheme provides substantial performance improvements compared to the point-to-point transmission in terms of BER in the case of error-free observations at the relay. Also, we studied the cooperative communication system with three relay location scenarios in case of errors occurring in the source-relay link. We distinguish that the best performance of cooperative system is obtained when the relay is closer to the destination than the source and the worst performance is taken when we keep the same distance between the three nodes (source, relay, destination). We showed that, for medium-to-low error probabilities, the proposed decoder remains resilient and we can have almost similar performance than the error-free case for an error probability less than 0.05.

REFERENCES

- [1] C. E. Shannon, "A mathematical theory of communication," *Bell System Technical Journal*, vol. 27, pp. 379–423, 623–656, 1948.
- [2] T. M. Cover and J. A. Thomas, "Elements of Information Theory," John Wiley, New York, 1991.
- [3] L. L. Pu, Z. Y. Wu, A. Bilgin, M. W. Marcellin, and B. Vasic, "LDPC-based iterative Joint Source-Channel decoding for JPEG200," *IEEE Trans. Image Processing Magazine*, vol. 16, no.2, pp. 577–581, Feb. 2007.
- [4] X. Jaspas, C. Guillemot, and L. Vandendorpe, "Joint Source-Channel turbo techniques for discrete-valued sources: from theory to practice", *Proc. of the IEEE*, vol. 95, no. 6, pp. 1345–1361, 2007.
- [5] D. Levine, W. E. Lynch, and T. Le-Ngoc, "Iterative Joint Source-Channel decoding of H. 264 compressed video," *Signal Commun.*, vol. 25, pp. 75–87, 2010.
- [6] J. Liu, G. Tu, C.Zhang, and Y. Yang, "Joint source and channel decoding for variable length encoded turbo codes," *EURASIP J. Advances in Signal Processing*, vol. 2008, no. 3, pp. 928–941, Jan. 2008.
- [7] H. Belhadj, S. Zaibi, and A. Bouallegue, "Iterative joint source-channel decoding with source statistics estimation: application to image transmission", *Sig. proc. image enhancement multimedia proc.*, Springer, pp. 301–311, 2008.

- [8] G. Zhu and F. Alajaji, "Joint Source-Channel turbo coding for binary Markov sources", *IEEE Trans. Wireless Commun.*, pp. 1065–1075, 2006.
- [9] M. Izhar, N. Faisal, X. Zhoo, K. Anwar, and T. Matsumoto, "Utilization of 2-D Markov source correlation using block turbo codes", *Proc. of the 7th Intl. Symposium on Turbo Codes and Iterative Information Processing 2012*, pp. 56–60, Gothenburg, Sweden, 2012.
- [10] T. J. Richardson, M. A. Shokrollahi, and R. L. Urbanke, "Design of capacity-Approaching Irregular Low-Density-Parity-Check codes", *IEEE Trans. Info. Theory.*, vol. 47, no. 2, pp. 619–637, February 2001.
- [11] M. Fresia, F. Pérez-Cruz, H. V. Poor, and S. Verdú, "Joint source and channel coding", *IEEE Sig. Proc. Mag.*, vol.27, no. 6, Nov. 2010.
- [12] M. Ben Abdesslem, A. Zribi, and A. Bouallegue, "Analysis of joint source channel low-density parity-check (LDPC) coding for correlated sources transmission over noisy channels", *to appear in proc. of Intl. Conf. Communications, Networking and Mobile Computing*, Paris, France, Mar. 2017.
- [13] J. N. Laneman, G. W. Wornell, and D. N. C. Tse, "An efficient protocol for realizing cooperative diversity in wireless networks," *IEEE Intl. Symposium Information Theory*, pp. 294, June 2001.
- [14] A. Sendonaris, E. Erkip, and B. Aazhang, "User cooperation diversity-part I: system description," *IEEE Trans. Com.*, vol. 51, no. 11, 2003.
- [15] J. N. Laneman, D. N. C. Tse, and G. W. Wornell, "Cooperative diversity in wireless networks: efficient protocols and outage behavior," *IEEE Trans. Inf. Theory*, vol. 50, no. 12, pp. 3062–3080, 2004.
- [16] T. Cover and A. Gamal, "Capacity theorems for the relay channel," *IEEE Transactions on Information Theory*, vol. 25, no. 5, pp. 572–584, Sept. 1979.
- [17] T. E. Hunter and A. Nosratinia, "Cooperation diversity through coding," *in proc. of the IEEE International Symposium on Information Theory*, pp. 220–221, July, 2002.
- [18] G. Kramer, M. Gastpar, and P. Gupta, "Cooperative strategies and capacity theorems for relay networks", *IEEE Transactions on Information Theory*, vol. 51, no. 9, pp. 3037–3063, 2005.
- [19] B. Zhao and M. C. Valenti, "Distributed turbo coded diversity for relay channel," *Electron. Lett.*, vol. 39, no. 10, pp. 786–787, May 2003.
- [20] Z. Zhang, and T. M. Duman, "Capacity-approaching turbo coding and iterative decoding for relay channels," *IEEE Trans. on Commu.*, vol. 53, no. 11, pp. 1895–1905, 2005.
- [21] M. Karkooti, and J. R. Cavallaro, "Cooperative communications using scalable, medium block-length LDPC codes," *Proc. Wireless Comm. Net. Conf.*, 2008.
- [22] D. Duyck, J. J. Boutros, and M. Moeneclaey, "Low-density graph codes for coded cooperation on slow fading relay channels," *IEEE Trans. on Information Theory*, vol. 57, no. 7, pp. 4202–4218, 2011.
- [23] J. P. Cances and V. Meghdadi, "Optimized Low-Density-Parity-Check codes designs for half duplex relay channels," *IEEE Transactions on Wireless Communications*, vol. 8, no. 7, pp. 3390–3395, 2009.
- [24] C. X. Li, G. S. Yue, M. A. Khojastepour, X. Wang, and M. M. Madhian, "LDPC-coded cooperative relay systems: performance analysis and code design," *IEEE Transactions on Communications*, vol. 56, no. 3, pp. 485–496, 2008.
- [25] S. Zhang, Y. Zhu, S. C. Liew, and K. Ben Letaief, "Joint design of network coding and channel decoding for wireless networks," *IEEE Wireless Comm. Net. Conf.*, pp. 779–784, Mar. 2007.
- [26] S. Yang, and R. Koetter, "Network coding over a noisy relay : a belief propagation approach," *IEEE Intl Symp. Inf. Theory*, Jun. 2007.
- [27] M. Xiao, and M. Skoglund, "Multiple-user cooperative communications based on linear network coding," *IEEE Trans. on Commu.*, vol. 58, no. 12, pp. 3345–3351, 2010.
- [28] A. D. Murugan, P. K. Gopala, and H. El Gamal, "Correlated sources over wireless channels: cooperative source-channel coding," *IEEE Jnl. selected areas in comm.*, vol. 22, no. 6, pp. 988–998, Aug. 2004.
- [29] X. Zhou, M. Cheng, k. Anwar, and T. Matsumodo, "Distributed joint source-channel coding for relay systems exploiting source-relay correlation and source memory," *EURASIP Jnl. Wireless Comm. Net.*, 2012.
- [30] A. Zribi, and R. Pyndiah, "Cooperative communication using turbo product codes with multiple-source spatial and temporal correlations," *In 2014 8th International Symposium on Turbo Codes and Iterative Information Processing (ISTC)*, pp. 249–253, Aug. 2014.
- [31] R. Youssef and A. Graell i Amat, "Distributed serially concatenated codes for multi-source cooperative relay networks," *IEEE Trans. Wirel. Commun.*, pp. 253–263, 2011.