

California State University, San Bernardino

**CSUSB ScholarWorks**

---

Theses Digitization Project

John M. Pfau Library

---

2000

## A middle school 6-8 drafting curriculum

David Charles Abdalla

Follow this and additional works at: <https://scholarworks.lib.csusb.edu/etd-project>



Part of the [Vocational Education Commons](#)

---

### Recommended Citation

Abdalla, David Charles, "A middle school 6-8 drafting curriculum" (2000). *Theses Digitization Project*. 1574.

<https://scholarworks.lib.csusb.edu/etd-project/1574>

This Project is brought to you for free and open access by the John M. Pfau Library at CSUSB ScholarWorks. It has been accepted for inclusion in Theses Digitization Project by an authorized administrator of CSUSB ScholarWorks. For more information, please contact [scholarworks@csusb.edu](mailto:scholarworks@csusb.edu).

A MIDDLE SCHOOL 6-8 DRAFTING CURRICULUM

---

A Project  
Presented to the  
Faculty of  
California State University,  
San Bernardino

---

In Partial Fulfillment  
of the Requirements for the Degree  
Master of Arts  
in  
Education:  
Vocational Education

---

by  
David Charles Abdalla

June 2000

A MIDDLE SCHOOL 6-8 DRAFTING CURRICULM

---

A Project  
Presented to the  
Faculty of  
California State University,  
San Bernardino

---

by  
David Charles Abdalla

June 2000

Approved by:

  
Joseph Scarcella, Ph.D., First Reader

5/26/00  
Date

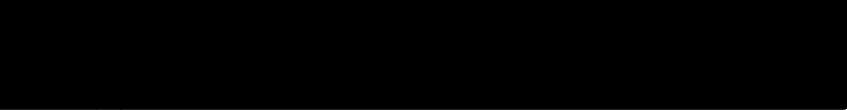
  
Ronald K. Pendleton, Ph.D., Second Reader

© 2000 David Charles Abdalla

## ABSTRACT

Preparing students for high school drafting and architecture presents interesting and unique challenges for vocational technical educators.

In today's public schools, it is imperative that educators view vocational technical education and technologies with a new and vibrant approach, with an understanding of the cross-curricular values and implications for students.

At present, the state of California has not recognized or established curriculum guidelines/frameworks addressing middle school drafting.

The purpose of this thesis was to develop a drafting core curriculum that could be successfully implemented at any middle school in any state. By establishing such a curriculum, it ensures that every student, at these grade levels, have the same exposure to all requirement and performance expectations.

The focus of this study was to develop a drafting program that was identified a student-centered-learning approach. Thus, adequately preparing students for entry level drafting at the high school level.

## ACKNOWLEDGMENTS

I would like to thank Dr. Joseph Scarcella, Vocational Education Department at California State University, San Bernardino, for his patience and endearing efforts in assisting me in my endeavor to successfully complete my Master's Degree. Dr. Scarcella spent countless hours reading and reviewing my work. He was a constant source of encouragement, guidance, and inspiration.

I would also like to thank Dr. Ronald Pendleton from the Vocational Education Department at California State University, San Bernardino, who encouraged me to enter and complete the Master's Degree in Vocational Education.

Timothy Thelander, whose knowledge of what a computer can do coupled with his computer skills, was a tremendous asset in the design and formatting of my thesis.

To my wife, Patti, throughout my coursework and thesis writings and corrections, she was the one constant pillar who was always there for me. Thank you for your endless support but most of all, for your love and caring.

## DEDICATION

This thesis is dedicated to all middle school drafting teachers. They are overflowing with knowledge in their field. Many are filled with enthusiasm and willingness to share without reservation.

When orating to the students the highest levels of expectations reflect on this, as kids, we too used rulers to draw lines before we knew about triangles and T-squares.

TABLE OF CONTENTS

ABSTRACT ..... iv

ACKNOWLEDGMENTS ..... iv

CHAPTER ONE Background

    Introduction ..... 1

    Context of the Problem ..... 1

    Purpose of the Project ..... 2

    Significance of the Project ..... 3

    Limitation and Delimitation ..... 4

        Limitation ..... 4

        Delimitation ..... 4

    Definition of Terms ..... 4

    Organization of the Project ..... 7

CHAPTER TWO Review of the Literature

    Introduction ..... 9

    Definition ..... 11

    Architectural Education - A Brief History ..... 12

    Expanded Curriculum Model ..... 14

    Today's Needs ..... 17

    School-To-Career ..... 17

        Parents: ..... 18

        Employers: ..... 18

        Students: ..... 18



Educators: .....	19
California's School-To-Career .....	19
Computer Technology in the Classroom .....	19
Summary .....	21
CHAPTER THREE Methodology	
Introduction .....	23
Course Outline .....	24
Reference Materials .....	27
CHAPTER FOUR Budgetary Considerations	
Introduction .....	29
CHAPTER FIVE Summary	
Introduction .....	31
Conclusions .....	31
Recommendations .....	32
Summary .....	32
APPENDIX A Questionnaire and Results .....	33
APPENDIX B A Middle School 6-8 Drafting Curricula .....	39
REFERENCES .....	118

## **CHAPTER ONE**

### **Background**

#### **Introduction**

The content of Chapter One provides an overview of 6-8 middle school drafting curriculum. The context of the problem is introduced, followed by the purpose and significance of the project. Limitation and delimitation that may apply to the project are followed by a definition of applicable terms. Chapter One concludes with the Organization of the Project.

#### **Context of the Problem**

The focus of teaching drafting at the middle school level was to introduce students to the basic "fundamentals" of drafting, equipment use, terminology, and beginning CAD (Computer-Aided Drafting) techniques. With this foundation, students are prepared to enter high school with a working knowledge of drafting skills and techniques.

Middle school drafting instructors have the expertise, coupled with their educational teaching skills, to facilitate information to their students. However, because of equipment costs and the need to continually upgrade, especially computer equipment, the capacity to always have the necessary equipment to successfully operate a program

can be prohibitive. Added to the challenge of developing a program with continuity is a poor selection of textbooks for the middle school level. After previewing numerous drafting and architectural textbooks, it was obvious that the scope of the writings were designed for high school and above.

Current textbooks provided for the middle school students are noticeably inadequate, primarily because they are written at a level that is difficult for many middle school students to successfully discern. Therefore, textbooks are generally used as supplementary resource material.

### **Purpose of the Project**

The purpose of the project was to develop a drafting curricula for middle school students grades 6-8. The design of the curricula focuses on specific drafting components and coursework at each grade level. The coursework was designed to articulate from one grade level to the next. Students at the sixth grade level are introduced to the 1/16" scale, which includes one-dimensional and three-dimensional line drawing. Students that have never used a ruler for anything other than drawing lines, learn that it has other purposes, such as measuring. Students at

the seventh grade level are introduced to the 1/4" scale and the use of an architect's scale. The final objective for these students was to successfully draw two distinctly different house floor plans. Eighth grade students expand on the seventh grade project of floor plans by drawing two different negative (white on black paper) elevation plans. This includes four elevation views (north, east, west, and south). Upon successfully completing this assignment, students are introduced to beginning CAD. Drawing lined floor plans and three-dimensional elevations with furnished floor plans on the computer are skills explored in the process.

At the completion of all three, grade levels, students will have developed a sound, fundamental understanding of drafting.

### **Significance of the Project**

Middle school teachers are teaching to a diverse cross-section of students. Students have varied learning abilities and skills levels. Middle school drafting teachers generally require varied equipment and resources for teaching drafting and CAD. The curricula incorporates three specific course-designed grade levels of drafting

objectives. Upon completing the three levels, students are prepared to begin high school drafting.

### **Limitation and Delimitation**

The limitations and delimitations are presented in the next section.

**Limitation.** The following limitation applies to this project:

- This curriculum is targeted for middle school in the high desert.

**Delimitation.** The following delimitation applies to this project:

- This curriculum could apply to any middle school drafting program.

### **Definition of Terms**

The following is a glossary of drafting terms most frequently associated with drafting, architecture, and CAD. Terms are not specific to individual grade levels; many of the terms are appropriate at all three grade levels.

Drawing Board: Used for backing attaching paper to drawing (Segel, 1962).

Drawing Paper: Paper used for the drawing projects; varies in sizes used from 8 1/2" x 11" to 18" x 24" (Segel, 1962).

T-Squares: A straightedge, made from a straight piece of wood, metal, or plastic. It can be used to draw straight lines in any direction (Segel, 1962).

Triangles: The two most frequently used triangles are: 30/60 degree and 45/90 degree (Segel, 1962).

Protractors: A measuring tool ranging from 0 degrees to 180 degrees used to measure or mark off angles (Segel, 1962).

Pencil Leads: Pencil leads with the letter "H" represent hard lead. As the number preceding the "H" on the pencil becomes higher; example, 3H, 4H, 5H, the lead becomes harder. Pencil leads with the letter "B" represent softer lead. As the number preceding the "B" on the pencil becomes higher; 3B, 4B, 5B, the lead becomes softer (Segel, 1962).

Erasing Shield: Used to protect lines adjacent to ones being erased (Segel, 1962).

Scales: Measuring tool used to determine size of drawings. Architect's Scales are the most widely used (Segel, 1962).

Compass: Used to draw circles and arcs (Segel, 1962).

Horizontal Lines: Lines drawn from the left to the right (Spencer and Dygdon, 1980).

Vertical Lines: Lines drawn up and down (Spencer and Dygdon, 1980).

Ames Lettering Instrument: Tool used for lettering (Spencer and Dygdon, 1980).

Orthographic Projection: Method of drawing an object with depth on a sheet of paper, which has only length and width (Segel, 1962).

Dimensions: Measurements of the completed drawing (Spencer and Dygdon, 1980).

Extension Lines: Located adjacent to drawing; not touching it. Touches dimension lines (Segel, 1962).

Dimension Lines: Used to show the true length of the part being measured (Segel, 1962).

Rise: The perpendicular distance of the roof (Segel, 1962).

Run: The Horizontal distance of one sloping part of a roof (Segel, 1962).

Floor Plans: A plan view of each floor. Floor plans may also indicate the thickness of inside and outside walls, the location of windows, doors, walls, stairs, electrical outlets, fireplaces, closets, etc. (Segel, 1962).

Elevations: Show the entire height of the structure, including any part below the ground floor (Segel, 1962).

CAD: Computer-Aided Drafting (CAD) software developed by Autodesk (Rupp, 1999).

Command: A code that directs the computer to perform a particular operation or sequence of operations (Shumaker, 1994).

Communication: The exchange of ideas, messages, or information (California Department of Education, 1996).

Computer Aided Drafting: The use of computers and peripheral devices to aid in the documentation of design projects (Rupp, 1999).

Cross-Curricular Instruction: The integration of one subject matter into one or more other subject matters (Johnston, 1999).

Hardware: The tools available to users of CAD for input, processing, and output (Rupp, 1999).

Software: A set of programs, procedures, rules, and possibly associated documentation concerned with the operation of a CAD system (Rupp, 1999).

### **Organization of the Project**

This project was divided into five parts. Chapter One provides an introduction to the context of the problem, purpose of the project, significance of the project, ending with limitations and delimitations. Chapter Two contains a review of literature. Chapter Three outlines the project design and the population of students to be served. Chapter



Four offers budget information. Chapter Five presents conclusions and recommendations generated from the project. Succeeding Chapter Five are the project and references.

## CHAPTER TWO

### Review of the Literature

#### Introduction

Chapter Two consists of literature relevant to the history of drafting and architecture, related cross-curricular disciplines, and a simple articulation from one level of understanding and competency to the next. Included is historical drafting and architectural information pertinent to other countries and how their influences affected drafting and architecture in the United States. Also included, are examples of how the drafting and architectural field articulate and operate within other academic disciplines. Defined examples demonstrate why there was a need for core academic disciplines to be an integral facet of a drafting and architectural course design from middle school through high school. The integration of academic and vocational education is a curricular and instructional strategy that makes learning more available and meaningful to all students. Integration also fosters teacher collaboration in curriculum planning and coordination of instruction (Berryman; et. al., November, 1992). In her study, Berryman recognized the need

for incorporating more academic content into vocational courses. She identified some viable models:

- Making the academic curriculum more vocationally relevant.
- Combining academic and vocational teachers to incorporate academic competencies in vocational courses.
- Modifying both academic and vocational curricula and curricular alignment. "Aligning curriculum horizontally," vocationally-oriented material is simultaneously introduced into academic courses and academically-relevant material is presented in vocational courses through the collaboration of academic and vocational teachers.

In a recent report, the Panel on Education Technology, PET, (1997) made the following suggestions:

- Emphasize content and pedagogy, and not just hardware (Panel of Education Technology, 1997).
- Technology should be embedded in the curriculum rather than taught as a separate subject; and
- The focus should be on learning with technology, not about technology (Christopher, 1999).

"The practice of architecture and drafting includes defining problems, evaluating alternatives, implementing solutions to better the environment, and enhance the quality of life; a blending of art and science. Using the power of architecture and the drafting design process can enhance learning and develop life skills at every level of education" (Barker, 1999).

### **Definition**

It can be defined as the practice of architecture, which includes defining problems, evaluating alternatives, and implementing solutions that can enhance learning and develop life skills. Drafting is a type of technical drawing that uses scales, T-squares, and different degree triangles to draw diagrams of objects. These objects range from machine parts to house plans. Drafting One is an introduction to the nature of drafting, design, engineering, and employment opportunities. It includes familiarization with terms and tools of the drafting trade, practice in geometric construction, orthographic projections, and Computer-Aided Drafting (CAD). A student's progress is evaluated through tests and application through drawings. After Drafting One, there are two general paths that a student may take. They can decide to take either

Drafting Two Architectural or Drafting Two Technical  
(Barker, December, 1999).

For the purpose of this project, understanding the target audience is middle school students, the emphasis of the drafting and architectural course design and implementation are more closely related to Drafting One. Entry-level drafting programs often include some architectural influence. A low to intermediate level CAD computer program, where emphasis is placed on the use of CAD to create residential construction plans, which include floor plans, wall sections, elevation drawings as well as other related drawings, is also included. Mathematics, science, and visual design concepts are reinforced.

#### **Architectural Education - A Brief History**

In 1814, Thomas Jefferson (the United State's only architect-president) proposed that a professional curriculum in architecture be established in the School of Mathematics of the University of Virginia. Unfortunately, the search for an appropriate architect/mathematician was fruitless and the University of Virginia delayed its entrance into the architectural field for many years. Instead, formal architectural education in the United States began in 1865 at the Massachusetts Institute of

Technology (MIT), five years after the institution's founding. MIT's action was followed in 1867 by the University of Illinois at Urbana and by Cornell University, in 1871.

The universities of Toronto and Montreal started the first schools of architecture in Canada in 1876. Also, during this period in time, in 1876 the blueprint process was introduced in this country at the Philadelphia Centennial Exposition. Up to this time "draughtmanship" was more or less an art expressing itself in fine lines, shading both by lines and washes, ornate borders, fancy lettering and the use of colors. These techniques became unnecessary after the introduction of blueprinting. The art of "draughting" was completely lost and the technology of "drafting" was discovered. This was the beginning of modern engineering and technical drawing. The first half of the 20th century could be characterized as the golden age of drafting. The modern technology of drafting was firmly recognized, and the application of graphic technology was found in engineering, design, manufacturing, production and architecture. Engineering, vocational-technical training in the area of drafting was greatly increased National

Association of Universities and Land-Grant Colleges  
(NASULGC, 1995).

The Morrill Act, passed by the United States Congress in 1862, had great and lasting repercussions for higher education. This included architecture. In exchange for land granted by Congress, colleges were expected to provide "practical" education for America's youth. This contrasted strongly with European education that more clearly separated education and training; at the university you were "educated", and, once in the office, you were "trained" (NASULGC, 1995).

### **Expanded Curriculum Model**

Current trends for teaching middle school students alternative drafting skills have expanded beyond the confines of the classroom (Rupp, 1999).

Students are demonstrating activities that incorporate the usefulness of mathematics in drafting along with the challenge and creativity of their imaginations.

For instance, at Scott Middle School in Fort Knox Kentucky, seventh-grade students are given several choices for an end-of-the-year project. The goal, to present students with problems that are challenging and incorporate many of the concepts that they have studied during the

year. Students were instructed to choose a house plan project from books provided or to find one in a book of their choice. Next, students choose a vacant lot in their neighborhood using string and stakes to map out a floor plan to actual size. Each student could choose to work in a small group of two to four people or alone. Students are to do their own scale drawings and written reports. They are allowed up to four weeks to complete the project. At the conclusion of the project, students were assessed on how well they used scales to transfer their plan to grid paper and to stake out their full-sized model, the quality of the mathematics used, and the quality of the written report (Teaching Pre K-8, 1999).

From this project, students learned not only mathematics, but also the value of accurate calculations and measurements. Mathematical errors sometimes caused students to create rooms that did not fit together as the plans showed. Constructing the model made such errors obvious. These errors lead to initial frustrations, students learned how to look for error sources to correct their own work. Students also learned other skills that were though useful in their future careers whether working alone or in groups. In addition, each project has been



designed to become a possible entry in the student's mathematics portfolio (Teaching Pre K-8, 1999).

Another example of cross-curricular academics is described in a classroom where a teacher developed a unit of study that connected architecture to the content areas of history, mathematics, and science (Christopher, 1999). The unit included a historical study of periods of architecture; a look at the relationship of different types of houses to their surrounding habitats; problem-solving activities that involved construction of bridges and towers; scale drawings of floor plans; and the study of mathematical concepts related to architecture (Christopher, 1999). The projects chosen by these students are prime examples of how in-depth and core oriented a drafting or architecture assignment can be. As an emphasis area in our school, reading and writing are essential elements in drafting. Quizzes designed to promote critical thinking, are given to students with the expectation that answers be written in sentences that are both clear and concise. Within the California State Framework, and the State's Standards currently being implemented, no subject area, whether core or elective, are designed to be

self-sufficient, that is, without the compliment of other curricular resources.

### **Today's Needs**

Today, more than 15 million students are enrolled in technical and vocational programs across the country. From fashion merchandising to food service, carpentry to computer repair, vocational technology students are preparing for careers in the 21st century.

Studies have shown that the demand for skilled workers in today's economy is greater than the number of students currently enrolled in vocational technology programs (Career World, 1998).

### **School-To-Career**

School-To-Career is an approach to education that links students, parents, schools, businesses, and labor to create a brighter future for all California. It is not a curriculum it is an educational philosophy. It is a new way of preparing students for entry into high school, college, and careers by making learning more relevant. Students taught in this manner do better academically, are committed to life-long learning, and gain a better understanding of the skills needed to be successful (as cited in Scarcella, 1999).

The following are examples of how the School-to-Career model works:

**Parents:**

- Gain satisfaction as their children learn skills that will help them lead successful, productive, and enriching lives.
- Fully participate with their children in the college and career planning process.
- See their children develop responsibility and a strong work ethic.
- Are excited their children are motivated to learn.

**Employers:**

- Partner with teachers to prepare a highly skilled and competitive workforce for California.
- Have employees who are prepared and motivated, and have a clear idea of their career goals.
- Make a valuable investment in their communities.

**Students:**

- Develop skills and understand how concepts learned in school are used at work.
- Develop a strong work ethic and increased self-confidence.

- Have knowledge and experiences to make wise career choices and be competitive in today's economy.
- Are prepared for further education careers.

**Educators:**

- See their students' motivation and performance levels rise when learning is linked to their interests.
- Enrich their own careers through internship and networking opportunities.
- Have access to new resources and teaching strategies that give context and purpose to the curriculum.

**California's School-To-Career**

- SHOWS students career choices
- PREPARES students for high school, college, careers, and citizenship.
- CREATES community-based partnerships.
- EDUCATES California's workforce for the 21<sup>st</sup> Century.
- CREATES a brighter future for California (as cited in Scarcella, 1999).

**Computer Technology in the Classroom**

Today's classrooms, beginning with elementary and continuing through college, are equipped with computers.

The field of computer technology and its impact upon us are

evident, functional, and necessary. As it was previously mentioned, students are preparing for the future, and the future is now. Computers and the technology necessary to run and maintain them are the life stream of today's society. In the educational field, a cross-section of curricular areas incorporating computer technology (i.e., mathematics, language arts, science, and technology education) shows that computers and technology are a vital element in the educational process. In middle school and high school drafting and architecture classes, CAD has become a primary tool in the students' preparation for post-secondary education and workforce employment. Areas that reflect almost solely the use of CAD programs are:

- Engineering: mechanical, structural, and design; and
- Fields of drafting and architecture.

"The vocational education program at the middle school level should give early adolescents a look at many careers and offer the opportunity to increase self-understanding as they prepare for an eventful occupation" (Kerka, 1994).

Vocational education can incorporate key middle school concepts in the following ways:

- Make exploration of life's work an integral part of the middle school core for learning to live and work in a culturally diverse world.
- Reflect developmental needs by helping students recognize their interests, aptitudes, and abilities in age-and stage-appropriate ways.
- Integrate vocational and academic education to promote intellectual development. "No real-world concepts, problems, or issues fit neatly into the jurisdiction of a single academic or vocational department".
- Assist with the development of social skills, personal values, and self-esteem through home economics/family life courses and the activities of vocational students organizations (Kerka, 1994).

### **Summary**

The aforementioned articles and examples are indicative of the importance of implementing other core content areas into the fields of drafting and architecture. It is imperative that vocational education instructors "reach out" to the other curricular, content areas, and show them what is being taught in the field of vocational education; bring to light the process of articulation

between core and vocational-technology disciplines  
(Scarcella, 1999).

In creating a solid foundation in mathematics and a comprehensive understanding of composition and writing skills, students are provided the essential tools to be successful in their future employment endeavors.

## CHAPTER THREE

### Methodology

#### Introduction

To successfully meet the needs of the middle school drafting students, materials are gathered from numerous sources. Materials and resources are used primarily in a supplementary capacity. The curricula was designed through the use of supplemental drafting textbooks, insight from instructors at neighboring middle schools, industry journals, selected high school expectations, and the teacher's knowledge and personally designed exercises, tests, quizzes, and assignments.

The purpose of this project was to develop an effective and comprehensive middle school 6-8 drafting program. Objectives for the students centered within the design of the course work are as follows:

- Enhance student learning.
- Prepare students for high school drafting and architecture.
- Create an atmosphere that entices the students' thirst for knowledge.
- Understand how to make use of scales in drafting.



- Complete assigned tasks.
- Develop a concise understanding of age-appropriate drafting; and
- Develop an understanding of introductory CAD.

For the purpose of this project, an outline of the course(s) consisting of the following parts is provided: Need for the course; Cultural Diversity; Expected Outcomes for the Students at Grade Levels; Course Content; Methods of Instruction; Typical Assignments; Methods of Evaluations; Texts used; and Equipment used.

#### **Course Outline**

##### I. Need for the Course.

With the exception of band and chorus students, all students at the middle school participate in drafting.

##### II. Cultural Diversity.

Students from various cultures and backgrounds make up the body of the classes.

##### III. Expected Outcomes for the Students by Grade Level.

At the conclusion of this course:

Sixth grade students will be able to:

- A. Understand and use the 1/16" scale,
- B. Successfully draw one-dimensional drawings;  
and
- C. Successfully draw three-dimensional drawings.

Seventh grade students will be able to:

- A. Understand and use the 1/4" scale.
- B. Successfully draw two house floor plans in detail.

Eighth grade students will be able to:

- A. Use the 1/4" scale to successfully draw two negative (white pencils on black paper) elevation views of houses.
- B. Successfully design three different houses with dimensions using CAD.

#### IV. Methods of Instruction.

The course incorporates collaborative learning, lecture, and individual study.

#### V. Assignments.

Sixth grade:

- A. Capital letters and numbers printing.
- B. Textbook printing (copy paragraphs in capital letters).

- C. Measurement identification (1/16" scale).
- D. One-dimensional drawings.
- E. Three-dimensional drawings.

Seventh grade:

- A. Capital letters and numbers printing.
- B. Measurement identification (1/4" scale).
- C. House floor plans.

Eighth grade:

- A. Capital letters and numbers printing.
- B. Measurement identification (1/4" scale).
- C. Negative drawings.
- D. CAD.

VI. Methods of Evaluation.

- A. Quizzes (objective grading).
- B. Tests (objective grading).
- C. Drawings (instructor's subjective grading).
- D. CAD (instructor's subjective grading).

VII. Text used.

"Basic Technical Drawing" (supplementary).

VIII. Equipment used.

Sixth grade.

- A. Drafting board.
- B. Rulers (1/16" scale).

C. 30/60 and 45/90 degree triangles.

D. T-squares.

Seventh grade.

A. Drafting board.

B. Architect's scale (1/4" scale).

C. 30/60 and 45/90 degree triangles.

D. T-squares.

Eighth grade.

A. Drafting board.

B. Architect's scale (1/4" scale).

C. 30/60 and 45/90 degree triangles.

D. T-squares.

F. Computers.

### **Reference Materials**

Vendors promoting textbooks for middle school drafting are limited. The textbooks previewed, were written for high school drafting classes. The supplemental text titled, "Basic Mechanical Drawing" was used. The preface of the book states it was designed primarily for the beginning-drafting student, whether in high school, junior college, technical school, or a four-year college. The text was the most closely related drafting book for middle school curriculum being taught. Additional supplemental

resource books used are: "Drafting Made Simple" and "Architecture Drafting and Design". After reviewing these texts, content outlines were developed for each grade level.

A questionnaire (Appendix A) was designed to survey local middle school drafting programs. The purpose of the questionnaire was two-fold: 1) Assist the instructor in reviewing and evaluating the content and resources of his course design; and 2) Get an accurate account of what High Desert instructors are teaching students in middle school drafting classes and to determine their course needs. The limitations in many classes are: 1) The use of proper teaching methodologies; 2) Equipment availability; 3) Equipment and software upgrades; 4) Fiscal support; and 5) Classes size for effective instruction. A questionnaire was given to teachers randomly and included non-specific grade level and specific grade level questions related to these needs.

## CHAPTER FOUR

### Budgetary Considerations

#### Introduction

Costs vary for a middle school drafting curriculum based upon the design of the program and the allowable discretionary funds from the administration.

The following provides a cost analysis of materials necessary for the project presented. Some of the materials such as paper, erasers, pencils, and construction paper are yearly consumables and need to be addressed in each year's budget. Additional budgetary items to be considered yearly and as needed are as follows:

1. Textbooks - 40 at a cost of \$22.00 ea.
2. 40 drafting boards at a cost of \$35.00 ea.
3. 5 reams of standard 8 1/2" x 11" white copy paper (500 copies per ream) at a cost of \$1.75 per ream.
4. 6 packages of 18" x 14" white construction paper (100 sheets per package) at a cost of \$2.50 per package.
5. 6 packages of 18" x 14" black construction paper (100 sheets per package) at a cost of \$2.50 per package.
6. 5 boxes of erasers (25 per box) at a cost of \$2.00 per box.

7. 6 packs of #2 pencils (60 total) at a cost of \$.30 per pack.
8. 20 compasses at a cost of \$4.50 ea.
9. 40 architectural scales at a cost of \$3.75 ea.
10. 40 rulers at a cost of \$1.25 ea.
11. 3 CAD simulated drafting programs at a total cost of \$325.00.
12. 15 iMac dual platform computers (Mac and Windows platforms) at a cost of \$1,000.00 ea.
13. 15 IBM-PC computers at a cost of \$1,100.00 ea.

The simulated CAD programs used by middle school students are generally not as technical or advanced as those used by high school drafting classes.

Understanding that the goal and responsibility of all educators were proposed to meet the comprehensive educational needs of all students. There needs to be a commitment from school administrators to budget for the advances of both hardware and software within this ever-changing world of computer technology.

## CHAPTER FIVE

### Summary

#### Introduction

As a result of the literature review, examining the current drafting program, and input from surrounding middle school drafting instructors, a number of conclusions and recommendations were formed. The chapter concludes with a summary.

#### Conclusions

In developing this project, the conclusions were made that there needs to be more support from administrators at the middle school level, particularly in the area of classroom equipment needs (i.e., drafting boards, computers, software, and hardware). Drafting programs at the middle school level, in the High Desert, are sorely in need of newer and upgraded drafting equipment. The mean for students to computers in a class setting, (Appendix A) survey, was a 3 to 1 students/computer/class ratio. There was also a great need for a middle school text that instructors and students can use as classroom reference. When instructors rely heavily on lecture, with an absence of a reference text, it can be more difficult for students



to retain information. Core academic departments are not giving recognition to drafting subject material.

### **Recommendations**

To help improve the quality of drafting programs it was recommended that core academic instructors acknowledge that drafting classes offer more than just a working knowledge of drawings. Focus should be placed on school-wide departments collaborating, integrating, and recognizing student achievement on a cross-curricular theme. The integration allows students to achieve vocational competencies as it fosters learning of abstract or theoretical concepts.

It was also recommended that administrators give adequate attention and budgetary support to drafting classes as well as to core subject classes.

### **Summary**

Conclusions and recommendations were formed as a result of reviewing the related literature and examining neighboring middle school drafting programs.

**APPENDIX A**

**Questionnaire and Results**

The questionnaire was sent to eight High Desert middle school drafting instructors. All instructors completed the questionnaire in its entirety. For the sake of comparison, each (anonymous) school's instructor was represented by a letter, A - H.

**1. How many periods do you teach in a day?**

A=7, B=7, C=7, D=7, E=7, F=7, G=7, H=7

**2. How many periods of drafting, board not CAD, do you teach?**

A=4, B=4, C=5, D=4, E=4, F=5, G=4, H=5

**3. For your board classes, what is the average number of students in each class?**

A=28, B=29, C=31, D=32, E=32, F=31, G=31, H=31

Mean average for all classes is 30.625.

**4. How many periods of CAD do you teach?**

A=3, B=1, C=1, D=1, E=1, F=2, G=1, H=1

**5. For your CAD classes, what is the average number of students in each class?**

A=28, B=30, C=30, D=31, E=30, F=30, G=32, H=30

Mean average for all classes is 30.125

**6. Do you have an adequate supply of boards and accessories to accommodate your board drafting classes?**

A=Y, B=Y, C=Y, D=Y, E=Y, F=Y, G=Y, H=Y

**7. Have you upgraded your boards and accessories within the past five years? If so, how many times?**

A=Y-1, B=Y-1, C=Y-1, D=Y-1, E=Y-1, F=Y-1, G=Y-1, H=Y-1

**8. Do you hold your CAD class(s) in your drafting classroom?**

A=Y, B=Y, C=Y, D=Y, E=Y, F=Y, G=Y, H=Y

**9. How many computers do you have in your classroom?**

Have the computers been upgraded with software or hardware within the past five years?

YA=20, YB=10, NC=10, ND=10, NE=8, NF=8, NG=8, NH=10

Mean average for computers in the classrooms is 10.5

**10. Do you use supplemental texts, and if so, how many do you have in your classroom?**

YA=30, YB=30, YC=35, YD=35, YE=32, YF=30, YG=32

**11. Do you know of any textbooks that are designed specifically for middle school drafting?**

A=N, B=N, C=N, D=N, E=N, F=N, G=N, H=N

12. Do you know of any textbooks that are designed specifically for middle school CAD?

A=N, B=N, C=N, D=N, E=N, F=N, G=N, H=N

13. Does your school give any cross-curricular credit for the drafting or CAD classes?

A=Y, B=N, C=N, D=N, E=N, F=N, G=N, H=N

14. How many years have you been teaching drafting classes? How many years have you been teaching at your present site?

A=14,10 B=3,3 C=4,2 D=4,4 E=7,3 F=2,2 G=2,2 H=3,2

Mean average for number of years taught is 4.875 years.

Mean average for number of years taught at instructor's present site is 3.5 years.

15. Do you teach individual grade level classes or are they mixed grade levels? I=Individual M=Mixed

A=I, B=I, C=I, D=M, E=M, F=M, G=M, H=I

16. Indicate the grade level(s) for your individual or mixed teaching assignments.

A=I,6-8 B=I,7 and 8 C=I,7 and 8 D=M,7/8 E=M,7/8 F=M,7/8

G=M,7/8 H=I,7 and 8

**17. Indicate the grade level(s) you teach board drafting and CAD. B=Board C=CAD**

A=6B,7B,8C B=7B,8C C=7B,8C D=7B,8BC E=7B,8BC, F=7B,8BC  
G=7B,8BC H=7B,8C

**18. Would you say that your CAD is a low, intermediate, or high level program?**

A=I, B=L, C=L, D=L, E=L, F=I, G=L, H=L

**19. What is the predominant scale(s) used by the students in the drafting classes?**

All eight sites emphasize the 1/16" and 1/4" scale.

The following questions are designed to be grade level specific.

**20. If you teach sixth grade drafting, what are the primary areas that the course is designed to cover, and how are the students evaluated?**

Only one of the middle schools polled, A, offered a sixth grade, drafting program. The focus of the course design was to teach entry level drafting skills. Students are assigned grades according to quiz scores, test scores, and drawing evaluations.

**21. If you teach seventh grade drafting, what are the primary areas that the course is designed to cover, and how are the students evaluated?**

All eight middle schools offer seventh grade drafting. The areas of emphasis vary from orthographic and isometric drawing to limited house floor plan design. Students are assigned grades according to quiz scores, test scores, and drawing evaluations.

**22. If you teach eighth grade drafting, what are the primary areas that the course is designed to cover, and how are the students evaluated?**

All eight middle schools offer eighth grade CAD. Six of the schools' instructors offer what they consider to be a low, entry-level CAD program; two of the instructors offer what they consider to be an intermediate level CAD program. All of the instructors assign grades based on proficiency levels that are successfully completed by the students.

**APPENDIX B**

**A Middle School 6-8 Drafting Curricula**



TABLE OF CONTENTS

INTRODUCTION TO THE DRAFTING PROJECT ..... 44

UNIT ONE SIXTH GRADE DRAFTING ..... 45

    Introduction ..... 46

        Practice Printing Worksheet ..... 48

        Practice Printing ..... 49

    Informational Handouts ..... 50

        Reading The Ruler ..... 51

        Sixteenths ..... 52

    Quizzes and Tests ..... 53

        Reading the Ruler: Quiz ..... 54

            Reading the Ruler: Quiz Answer Sheet ..... 55

        Recognizing Sixteenths on the Scale: Quiz ..... 56

            Sixteenths Scale: Quiz Answer Sheet ..... 57

        Short Ruler Quiz ..... 58

            Short Ruler: Quiz Answer Sheet ..... 59

        Understanding the 1/16" Scale: Quiz ..... 60

            1/16" Scale: Quiz Answer Sheet ..... 61

        Line Measurement "A": Quiz ..... 62

            Line Measurement "A": Quiz Answer Sheet ... 63

        Line Measurement "B": Quiz ..... 64

            Line Measurement "B": Quiz Answer Sheet ... 65

        Fractional Inch Top and Bottom: Quiz ..... 66

Fractional Inch Top: Quiz Answer Sheet . . . .	67
Fractional Inch Bottom: Quiz Answer Sheet .	68
Drafting Terminology . . . . .	69
Drafting Terminology: Quiz . . . . .	70
Drafting Terminology: Quiz Answer Sheet . . .	71
Line Development . . . . .	72
DRAFTING BIBLE . . . . .	73
Construction Lines . . . . .	74
Drawings . . . . .	75
One-Dimensional Student Drawing . . . . .	76
Simple Three-dimensional Student Drawing . . . . .	77
Difficult Three-Dimensional Student Drawing . . . .	78
UNIT TWO Seventh Grade Drafting . . . . .	79
Introduction . . . . .	80
1/4" Scale . . . . .	82
1/4" Scale Guide Sheet . . . . .	83
1/4" Scale: Quiz . . . . .	84
1/4" Scale: Quiz Answer Sheet . . . . .	85
Fractional Inch Top And Bottom Directions:	
1/4" Scale Quiz . . . . .	86
Fractional Inch Top and Bottom: Quiz . . . . .	87
Fractional Inch: Quiz Answer Sheet . . . . .	88
Framing-Doors-Windows . . . . .	89

Framing-Doors-Windows: Quiz .....	90
Framings-Doors-Windows: Quiz Answer Sheet .	91
Electrical Symbols .....	92
Electrical Symbols: Test .....	93
Electrical Symbols: Test Answer Sheet .....	94
Elements of a House .....	95
Elements of a House: Test .....	96
Elements of House: Test Answer Sheet .....	97
Elements of a House .....	98
Elements of a House-Quiz .....	99
Elements of a House - Answer Sheet .....	100
North Elevation Negative Drawing-House .....	101
South Elevation Negative Drawing-House .....	102
Architectural Symbols .....	103
Floor Plan in Three Stages .....	104
Three Bedroom Floor Plan .....	105
Two Bedroom Floor Plan .....	106
1470 Student Floor Plan .....	107
1698 Student Floor Plan .....	108
UNIT THREE Eighth Grade Drafting .....	109
Introduction .....	110
Floor Plan #1 .....	113
Floor Plan #2 .....	114

Floor Plan #3 .....	115
Floor Plan #4 .....	116
Loan Amortization/Cost Estimation Sheet .....	117

## INTRODUCTION TO THE DRAFTING PROJECT

The following project is divided into three units:

Unit One: Sixth Grade Drafting, Unit Two: Seventh Grade Drafting, and Unit Three: Eighth Grade Drafting. The curriculum includes worksheets, informational handouts, quizzes, tests, answer sheets, coursework examples, grade level drawings, and student work. The design of the coursework is sequential within each unit level and from grade-to-grade. Students are provided with the necessary information, skills, and techniques to successfully complete a middle school drafting curricula and advance to the next level of study; high school.

Students who have never had any drafting courses may transfer in from other schools and enter one of the three drafting curricula, by grade level, at any time. Though it may be difficult at first, the students receive all necessary help to bring them to the level of the existing students. Although it should be noted, students who have participated in the program through all three levels have a distinct advantage over students who have not.

SIXTH GRADE DRAFTING

UNIT ONE

## **Introduction**

The sixth-grade drafting program is designed to introduce entry level drafting skills and techniques to the students. Students use vertical capital letters, i.e., A, B, C, D, E, M, R, W, and a specified number style, i.e., 1, 2, 4, 7, 8. Students are also introduced to the 1/16" scale as an introductory drafting tool for measurement of straight line drawing. Quizzes and tests are administered to the students to evaluate their ability to successfully identify drafting terminology and the 1/16" scale. Students use 30/60 and 45/90 degree triangles in conjunction with drafting boards, T-squares, and templates to complete one-dimensional and three-dimensional drawing assignments. All assignments, quizzes, tests, and drawings are given grades based on a one hundred percent (100%) scale.

Upon the completion of the sixth grade drafting curriculum, students will be able to:

- Print letters and numbers correctly.
- Understand and use Drafting Terminology.
- Display the ability to measure using the 1/16" scale.
- Identify the various drafting tools used for drawings.
- Draw one-dimensional and three-dimensional objects.

When students are first introduced to drafting, an introduction to the industry standard of lettering and numbering is necessary. In drafting and architecture the standard for printing letters is to use vertical capitals. With numbers, the standard is to use vertical numerals.

The following worksheet is used to introduce the students to vertical capital letters and vertical numerals. Students are to print ten rows of capital letters, just as the examples show, on the numbered rows skipping a line between each row. After completing the capital letters assignment, they are to print nine rows of numbers, as the examples, on the numbered rows skipping a line between each row.

For additional follow-up exercises, students will copy selected writings from the supplementary drafting textbook, using the Practice Printing worksheet provided, in capital letter form and copying numbers in vertical form.



Practice Printing Worksheet

FIRST AND LAST NAME \_\_\_\_\_ DATE \_\_\_\_\_

PERIOD \_\_\_\_\_

A B C D E F G H I J K L M N O P Q R S T U V W X Y Z

1

2

3

4

5

6

7

8

9

10

1 2 3 4 5 6 7 8 9 0

1

2

3

4

5

6

7

8

9



## **Informational Handouts**

Prior to testing and drawing assignments, students receive informational handouts specific to reading the ruler in the 1/16" scale. These handouts are discussed in-depth within the class. Students are to keep the handouts in their folders for reference.

## Reading The Ruler

1. In reading the standard ruler (sixteenths) every line, no matter how big or small, is equal to one (1) sixteenth of an inch =  $1/16''$
2. Therefore, it takes sixteen (16) sixteenths to equal one inch. It doesn't matter where you count from on the ruler, every sixteen lines will always be equal to inch
3. Every two - sixteenths is equal to one eighth of an inch.  $1/8''$
4. Every four - sixteenths is equal to one quarter of an inch.  $1/4''$
5. Every eight - sixteenths of an inch is equal to one half of an inch.  $1/2''$
6. All even numbered fractions are able to be, and should be, reduced.
7. The only denominators, bottom number, in any fractions in the standard ruler using sixteenths can be .. 16, 8, 4, and 2. If any other number comes up as a denominator your fraction is incorrect.

## Sixteenths

1. On the standard ruler, based on sixteenths, every line represents one-sixteenth ( $1/16''$ ) of an inch.
2. No matter where you begin counting from, every increment =  $1/16''$  of an inch. An example of a standard ruler is drawn below. The ruler is not drawn to scale but, rather, drawn so that you can see the representation of the individual sixteenths.

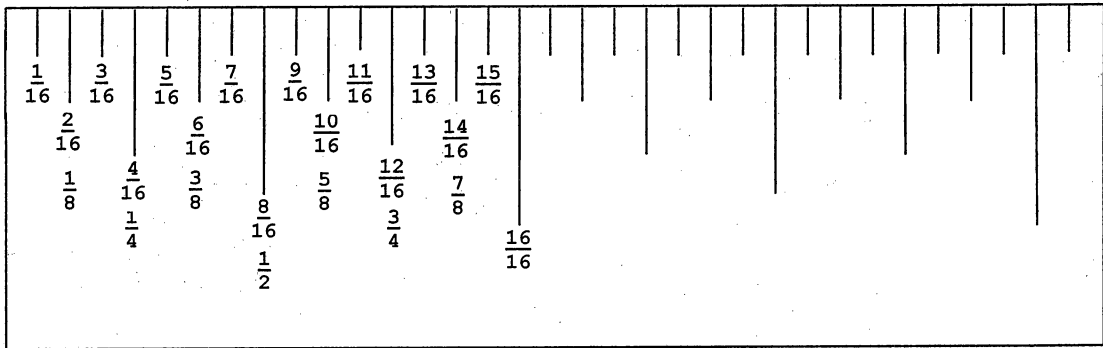

3. Every two-sixteenths ( $2/16''$ ) of an inch, when reduced, =  $1/8''$
4. Every four-sixteenths ( $4/16''$ ) of an inch, when reduced, =  $1/4''$
5. Every eight-sixteenths ( $8/16''$ ) of an inch, when reduced, =  $1/2''$

## **Quizzes and Tests**

The design of the quizzes and tests is to be used as an instrument to evaluate sixth grade students in areas, which includes but is not limited too, mathematical, cognitive, and motor skills understanding coupled with a display of competency in the entry-level techniques of drafting. Following the quizzes will be answer sheets.

The initial quizzes and tests the students take are specific to understanding and recognizing fractions through measurements in the  $1/16''$  scale. All fractions that can be, are to be reduced at all times. The following quizzes and tests are multiple choice, fill-in, recognize and answer, or measure and answer using the ruler. After each quiz will be the corresponding answer sheet.

### Reading the Ruler: Quiz

1. WHEN READING THE STANDARD RULER, EVERY LINE. NO MATTER HOW BIG OR SMALL IS EQUAL TO WHAT MEASUREMENT?  
SR"  
A.  $1/2$ "  
B.  $1/4$ "  
C.  $1/16$ "  
D.  $1/8$ "
2. THE ONLY DENOMINATORS, BOTTOM NUMBER, IN A SIXTEENTH INCH RULER CAN BE WHAT?  
A. 2, 4, 6, AND 16  
B. 2, 8, 12, AND 16  
C. 2, 6, 8, AND 16  
D. 2, 4, 8, AND 16
3. IT TAKES \_\_\_\_\_ SIXTEENTHS TO EQUAL ONE INCH. IT DOESN'T MATTER WHERE YOU COUNT FROM ON THE RULER. EVERY \_\_\_\_\_ LINES WILL BE EQUAL TO ONE INCH.  
A. 12  
B. 16  
C. 14  
D. 18
4. EVERY  $2/16$ " IS EQUAL TO  
A.  $1/4$ "  
B.  $1/16$ "  
C.  $1/8$ "  
D.  $1/2$ "
5. EVERY EIGHT-SIXTEENTHS IS EQUAL TO  
A.  $1/2$ "  
B.  $1/8$ "  
C.  $1/4$ "  
D.  $1/16$ "
6. EVERY FOUR-SIXTEENTHS IS EQUAL TO  
A.  $1/8$ "  
B.  $1/16$ "  
C.  $1/2$ "  
D.  $1/4$ "

**Reading the Ruler: Quiz Answer Sheet**

1. C  $1/16''$
2. D 2, 4, 8, AND 16
3. B 16
4. C  $1/8''$
5. A  $1/2''$
6. D  $1/4''$



### Recognizing Sixteenths on the Scale: Quiz

Identify the measurement that the arrow points to.  
Start counting the arrows from left to right and 1-15.

Remember to reduce whenever possible.

Place your answers on the line next to the number that  
corresponds to the arrow.

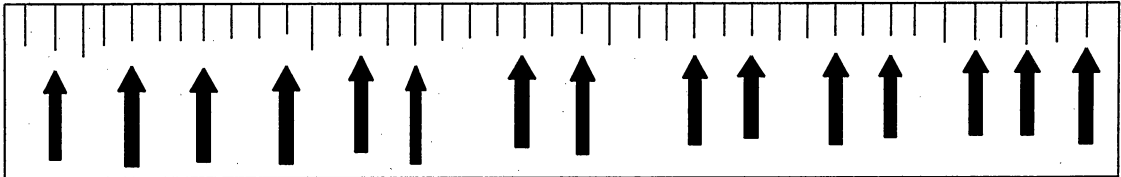

1. \_\_\_\_\_ 2. \_\_\_\_\_ 3. \_\_\_\_\_ 4. \_\_\_\_\_ 5. \_\_\_\_\_  
6. \_\_\_\_\_ 7. \_\_\_\_\_ 8. \_\_\_\_\_ 9. \_\_\_\_\_ 10. \_\_\_\_\_  
11. \_\_\_\_\_ 12. \_\_\_\_\_ 13. \_\_\_\_\_ 14. \_\_\_\_\_ 15. \_\_\_\_\_

### Sixteenths Scale: Quiz Answer Sheet

1. =  $1/8''$       2. =  $5/16''$       3. =  $1/2''$       4. =  $11/16''$   
5. =  $7/8''$       6. =  $1''$       7. =  $1\ 1/4''$       8. =  $1\ 3/8''$   
9. =  $1\ 5/8''$     10. =  $1\ 3/4''$     11. =  $1\ 15/16''$     12. =  $2\ 1/16''$   
13. =  $2\ 1/4''$     14. =  $2\ 3/8''$     15. =  $2\ 1/2''$

# Short Ruler Quiz

FIRST AND LAST NAME \_\_\_\_\_ DATE \_\_\_\_\_

PERIOD \_\_\_\_\_

Identify The Measurement Above The Arrow

1.

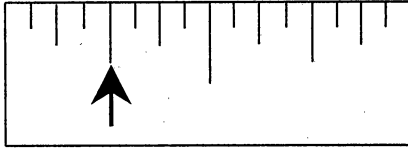

6.

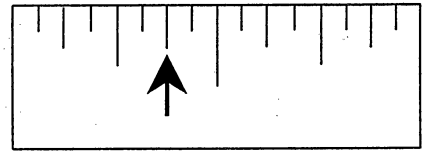

2.

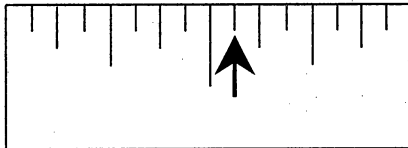

7.

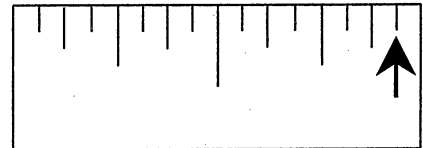

3.

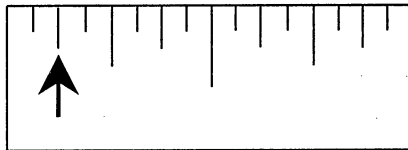

8.

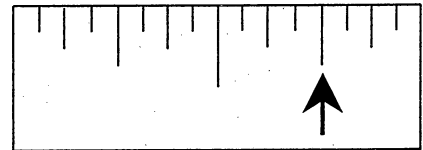

4.

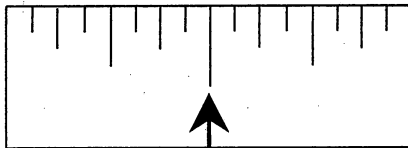

9.

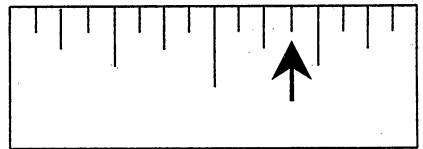

5.

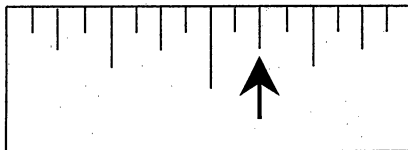

10.

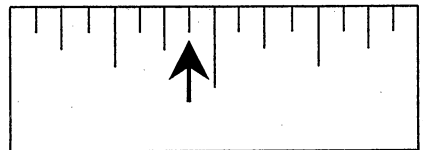

2"

3"

3"

4"

1"

1"

2"

### Short Ruler: Quiz Answer Sheet

1.  $\frac{1}{4}$ "
2.  $\frac{9}{16}$ "
3.  $\frac{1}{8}$ "
4.  $1 \frac{1}{2}$ "
5.  $1 \frac{5}{8}$ "
6.  $2 \frac{3}{8}$ "
7.  $3 \frac{15}{16}$ "
8.  $3 \frac{3}{4}$ "
9.  $4 \frac{11}{16}$ "
10.  $2 \frac{7}{16}$ "

## Understanding the 1/16" Scale: Quiz

Fill in the blank.

1. In the 1/16" Scale, how many sixteenths equals 1"?  
\_\_\_\_\_
2. 2" equals how many sixteenths? \_\_\_\_\_
3. 1 1/4" equals how many sixteenths? \_\_\_\_\_
4. 6/8" equals how many sixteenths? \_\_\_\_\_
5. The only denominators used in the 1/16" Scale are?  
\_\_\_\_, \_\_\_\_, \_\_\_\_, and \_\_\_\_
6. 19/16" equals what measurement? \_\_\_\_\_
7. 1/2" equals how many sixteenths? \_\_\_\_\_
8. 7/16" + 9/16" equals what measurement? \_\_\_\_\_
9. 6/16" equals what measurement? \_\_\_\_\_
10. 5/8" equals how many sixteenths? \_\_\_\_\_

**1/16" Scale: Quiz Answer Sheet**

1. 16
2. 32
3. 20
4. 12
5. 2, 4, 8, AND 16
6.  $1 \frac{3}{16}$ "
7. 8
8. 1"
9.  $\frac{3}{8}$ "
10.  $\frac{10}{16}$ "

### Line Measurement "A": Quiz

Measure the line segment and put the answer on the blank just to the right of the line segment. If the measurement falls between two of the sixteenths lines, you may choose either measurement. Be sure to reduce whenever possible!

1. \_\_\_\_\_
2. \_\_\_\_\_
3. \_\_\_\_\_
4. \_\_\_\_\_
5. \_\_\_\_\_
6. \_\_\_\_\_
7. \_\_\_\_\_
8. \_\_\_\_\_
9. \_\_\_\_\_
10. \_\_\_\_\_

**Line Measurement "A": Quiz Answer Sheet**

1.  $1 \frac{5}{16}$ " OR  $1 \frac{1}{4}$ "
2.  $2$ " OR  $2 \frac{1}{16}$ "
3.  $\frac{1}{4}$ " OR  $\frac{5}{16}$ "
4.  $2 \frac{1}{2}$ " OR  $2 \frac{9}{16}$ "
5.  $1 \frac{5}{16}$ "
6.  $3 \frac{7}{16}$ "
7.  $2 \frac{5}{8}$ " OR  $2 \frac{11}{16}$ "
8.  $1 \frac{1}{2}$ "
9.  $\frac{5}{16}$ " OR  $\frac{3}{8}$ "
10.  $3 \frac{3}{4}$ " OR  $3 \frac{13}{16}$ "



### Line Measurement "B": Quiz

Measure the lines and put the answer on the blank.

Each line measured has a letter that corresponds to a blank where the answer is put. If the measurement falls between lines, choose either measurement. Be sure to reduce whenever necessary!

1. \_\_\_\_\_
2. \_\_\_\_\_
3. \_\_\_\_\_
4. \_\_\_\_\_
5. \_\_\_\_\_
6. \_\_\_\_\_
7. \_\_\_\_\_
8. \_\_\_\_\_
9. \_\_\_\_\_
10. \_\_\_\_\_

**Line Measurement "B": Quiz Answer Sheet**

1.  $3 \frac{5}{8}$ " OR  $3 \frac{11}{16}$ "
2.  $3 \frac{1}{4}$ " OR  $3 \frac{5}{16}$ "
3.  $\frac{9}{16}$ " OR  $\frac{5}{8}$ "
4.  $1 \frac{1}{4}$ " OR  $1 \frac{5}{16}$ "
5.  $2 \frac{3}{4}$ " OR  $2 \frac{15}{16}$ "
6.  $1 \frac{13}{16}$ " OR  $1 \frac{7}{8}$ "
7.  $2 \frac{3}{8}$ " OR  $2 \frac{7}{16}$ "
8.  $2 \frac{3}{16}$ "
9.  $3 \frac{5}{16}$ " OR  $3 \frac{3}{8}$ "
10.  $\frac{7}{8}$ " OR  $\frac{15}{16}$ "

## Fractional Inch Top and Bottom: Quiz

Determine the length of each of the lettered dimension lines on the scale below. Letter each dimension in the corresponding spaces at the right. Letter carefully within the guidelines. Letter A is given as an example. Add arrowheads to the ends of the dimension lines.

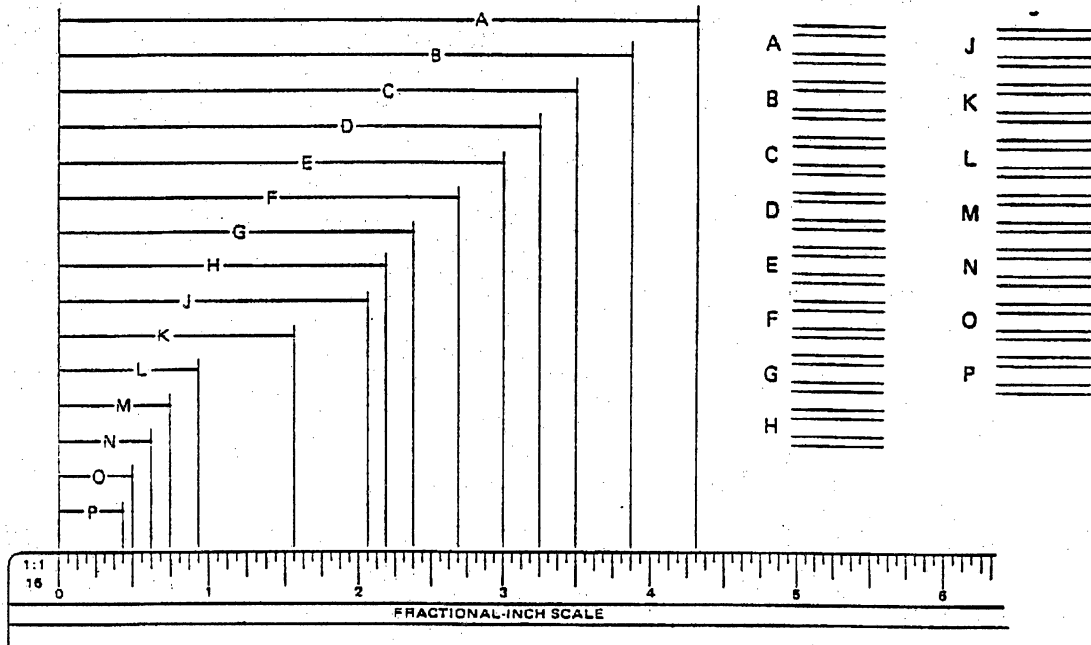

Using a full-size fractional-inch scale, measure each of the lettered lines in the figure below. Record the length of each in its corresponding space at the right. Measure all lines to the nearest 16th of an inch.

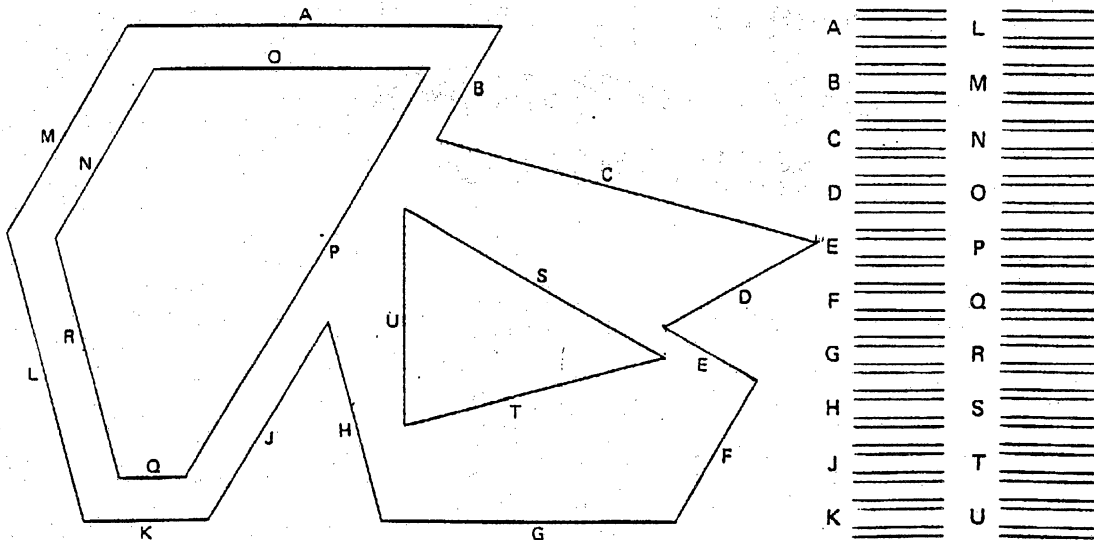

**THE USE AND CARE OF  
DRAFTING EQUIPMENT**

DRAWN BY .....

DATE .....

DWG NO. ....

## Fractional Inch Top: Quiz Answer Sheet

1. 4 5/16"

2. 3 7/8"

3. 3 1/2"

4. 3 1/4"

5. 3"

6. 2 11/16"

7. 2 3/8"

8. 2 3/16"

9. 2 1/16"

10. 1 9/16'

11. 15/16'

12. 3/4"

13. 5/8"

14. 1/2"

15. 7/16"

**Fractional Inch Bottom: Quiz Answer Sheet**

1.  $2 \frac{1}{2}$ " OR  $2 \frac{9}{16}$ "
2.  $\frac{7}{8}$ " OR  $\frac{15}{16}$ "
3.  $2 \frac{3}{4}$ "
4.  $1 \frac{3}{16}$ "
5.  $\frac{3}{4}$ "
6.  $1 \frac{1}{8}$ "
7.  $2$ " OR  $2 \frac{1}{16}$ "
8.  $1 \frac{3}{8}$ " OR  $1 \frac{7}{16}$ "
9.  $1 \frac{9}{16}$ "
10.  $\frac{13}{16}$ " OR  $\frac{7}{8}$ "
11.  $2 \frac{1}{16}$ "
12.  $1 \frac{5}{8}$ " OR  $1 \frac{1}{16}$ "
13.  $1 \frac{5}{16}$ " OR  $1 \frac{3}{8}$ "
14.  $1 \frac{7}{8}$ "
15.  $3 \frac{1}{4}$ " OR  $3 \frac{5}{16}$ "
16.  $\frac{7}{16}$ "
17.  $1 \frac{3}{4}$ "
18.  $2 \frac{1}{16}$ "
19.  $1 \frac{13}{16}$ " OR  $1 \frac{7}{8}$ "
20.  $1 \frac{1}{2}$ " OR  $1 \frac{9}{16}$ "

## **Drafting Terminology**

In the middle school sixth grade-drafting curriculum there are identifiable terms, which students will need to understand and use regularly when in a drafting class. The following quiz is designed to test the students' knowledge of a sample of such terms.

## Drafting Terminology: Quiz

MATCH THE LETTER OF THE DEFINITION TO THE CORRECT  
TERM.

WRITE THE ANSWER ON YOUR OWN SHEET OF PAPER

- |                            |  |
|----------------------------|--|
| _____ PROTRACTOR           | A. ITEM USED TO MEASURE<br>LINES                           |
| _____ AMES LETTERING GUIDE | B. TYPES OF TRIANGLES                                      |
| _____ 2H, 4H, 3B, 5B, F    | C. USED ON A DRAFTING<br>BOARD TO DRAW<br>HORIZONTAL LINES |
| _____ ERASING SHIELD       | D. USED AS A PRINTING<br>TOOL                              |
| _____ 45/90 or 30/60       | E. TYPES OF PENCIL LEADS                                   |
| _____ DRAFTING BOARD       | F. USED TO MEASURE<br>ANGLES                               |
| _____ T-SQUARE             | G. USED TO PROTECT LINES<br>WHILE ERASING OTHER<br>ONES    |
| _____ ARCHITECT'S SCALE    | H. ITEM THAT DRAFTING<br>PAPER IS ATTACHED TO              |

## Drafting Terminology: Quiz Answer Sheet

MATCH THE LETTER OF THE DEFINITION TO THE CORRECT TERM.

- |          |                      |    |   |
|----------|----------------------|----|---|
| <u>F</u> | PROTRACTOR           | A. | ITEM USED TO MEASURE LINES                        |
| <u>D</u> | AMES LETTERING GUIDE | B. | TYPES OF TRIANGLES                                |
| <u>E</u> | 2H, 4H, 3B, 5B, F    | C. | USED ON A DRAFTING BOARD TO DRAW HORIZONTAL LINES |
| <u>G</u> | ERASING SHIELD       | D. | USED AS A PRINTING TOOL                           |
| <u>B</u> | 45/90 or 30/60       | E. | TYPES OF PENCIL LEADS                             |
| <u>H</u> | DRAFTING BOARD       | F. | USED TO MEASURE ANGLES                            |
| <u>C</u> | T-SQUARE             | G. | USED TO PROTECT LINES WHILE ERASING OTHER ONES    |
| <u>A</u> | ARCHITECT'S SCALE    | H. | ITEM THAT DRAFTING PAPER IS ATTACHED TO           |



## **Line Development**

Before students begin drawings, there are specific lines used to outline, to create, and to define the drawing. The following handouts give thorough explanation of proper line usage.

DRAFTING BIBLE

**DO NOT LOSE THIS PAPER...IT IS YOUR  
DRAFTING BIBLE**

- A. BORDER LINES ARE 1/4" (4/16") FROM ALL SIDES
- B. BORDER LINES ARE **DARK** LINES
- C. TITLE BOX LINES ARE 3/16" APART AND THERE ARE 4 OF THEM
- D. TITLE BOX LINES ARE **DARK** LINES
- E. CORNER LAYOUT LINES ARE LOCATED 1" OVER AND 1" UP FROM THE TOP LEFT-HAND CORNER OF THE TITLE BOX AND BORDER LINE
- F. CORNER LAYOUT LINES ARE CONSTRUCTION LINES
- G. CORNER LAYOUT LINES ARE **VERY LIGHT** LINES
- H. ALL LINES FOR THE DRAWING ARE **DARK** LINES
- I. EXTENSION LINES ARE DARK LINES
- J. EXTENSION LINES **NEVER** TOUCH THE DRAWING
- K. EXTENSION LINES ARE TO BE STARTED ABOUT 1/8" FROM THE POINT OF MEASUREMENT ON THE DRAWING
- L. DIMENSION LINES ARE **DARK** LINES
- M. DIMENSION LINES WITH ARROWS, **ALWAYS** TOUCH THE EXTENSION LINES
- N. FRACTIONS ARE WRITTEN THIS WAY:  $\frac{1}{2}$  NOT: 1/2
- O. DIMENSION NUMBERS ARE ALWAYS WRITTEN RIGHT-SIDE UP NOT UPSIDE DOWN
- P. THE ONLY FREEHAND DRAWING SHOULD BE NUMBER, LETTERS, AND ARROWS ... ALL OTHER PARTS SHOULD BE DRAWN WITH A STRAIGHT EDGE (TRIANGLE OR GUIDE ... NOT A SCALE)
- Q. BE SURE TO CHECK **ALL** ASPECTS OF YOUR DRAWING BEFORE YOU TURN IT IN TO ME; WHEN YOUR DRAWING HITS MY TRAY IT WILL BE GRADED ACCORDING TO WHAT YOU HAVE OR HAVE NOT COMPLETED!!

## **CONSTRUCTION LINES**

1. WHEN YOU MEASURE ACROSS ON THE BOTTOM, YOUR CONSTRUCTION LINE GOES UP
2. WHEN YOU MEASURE ACROSS ON THE TOP, YOUR CONSTRUCTION LINE GOES DOWN
3. WHEN YOU MEASURE UP ON THE RIGHT, YOUR CONSTRUCTION LINE GOES TO THE LEFT
4. WHEN YOU MEASURE UP ON THE LEFT, YOUR CONSTRUCTION LINE GOES TO THE RIGHT

## **Drawings**

After all quizzes and tests have been completed and the students have learned the uses of lines the final aspect of the class begins, the drawings.

On the following pages are displayed examples of drawings the students do in class. One is a student's simple one-dimensional drawing, another is a simple three-dimensional drawing, and the third is a more difficult three-dimensional drawing that one of the students successfully drew.

One-Dimensional Student Drawing

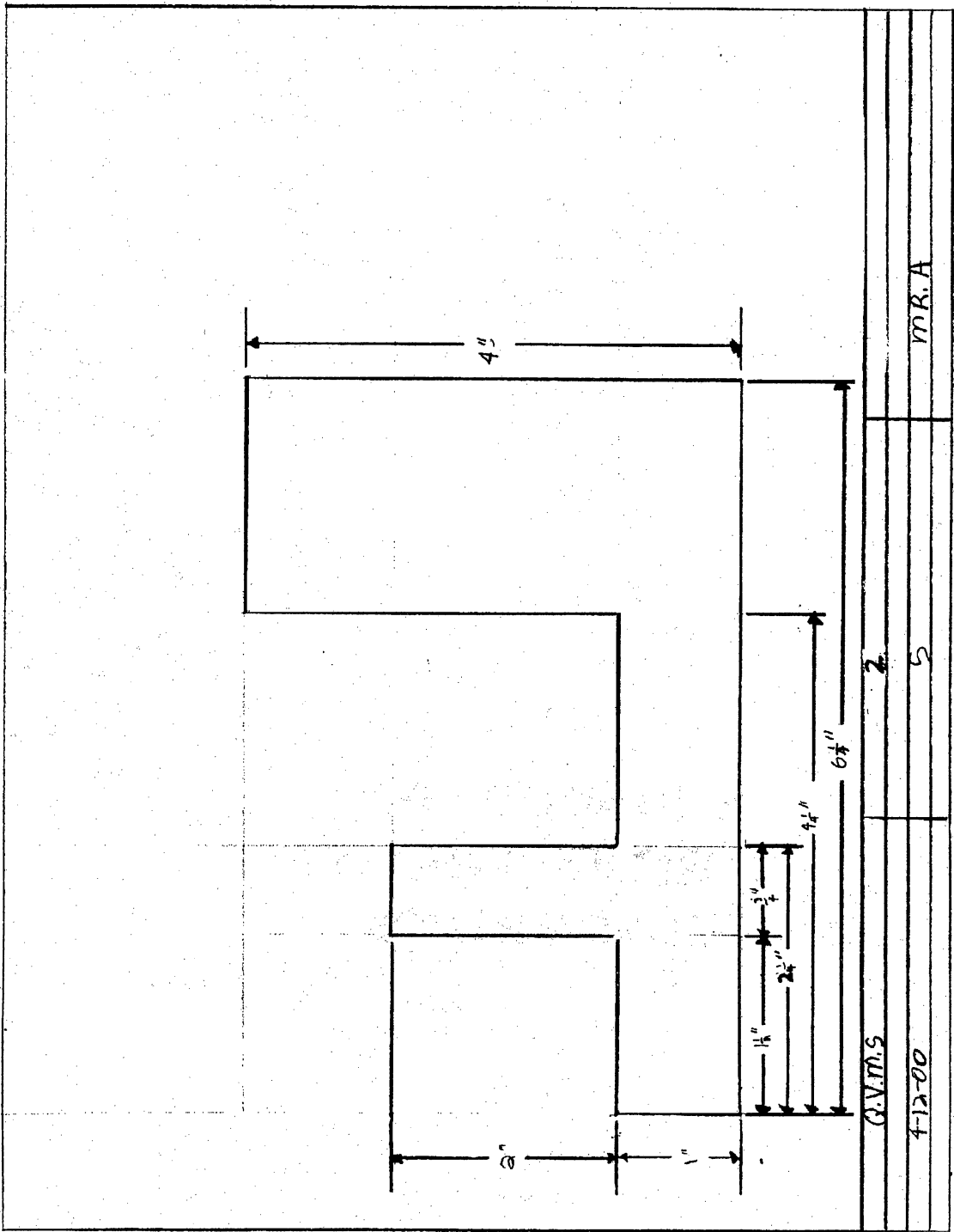

Simple Three-dimensional Student Drawing

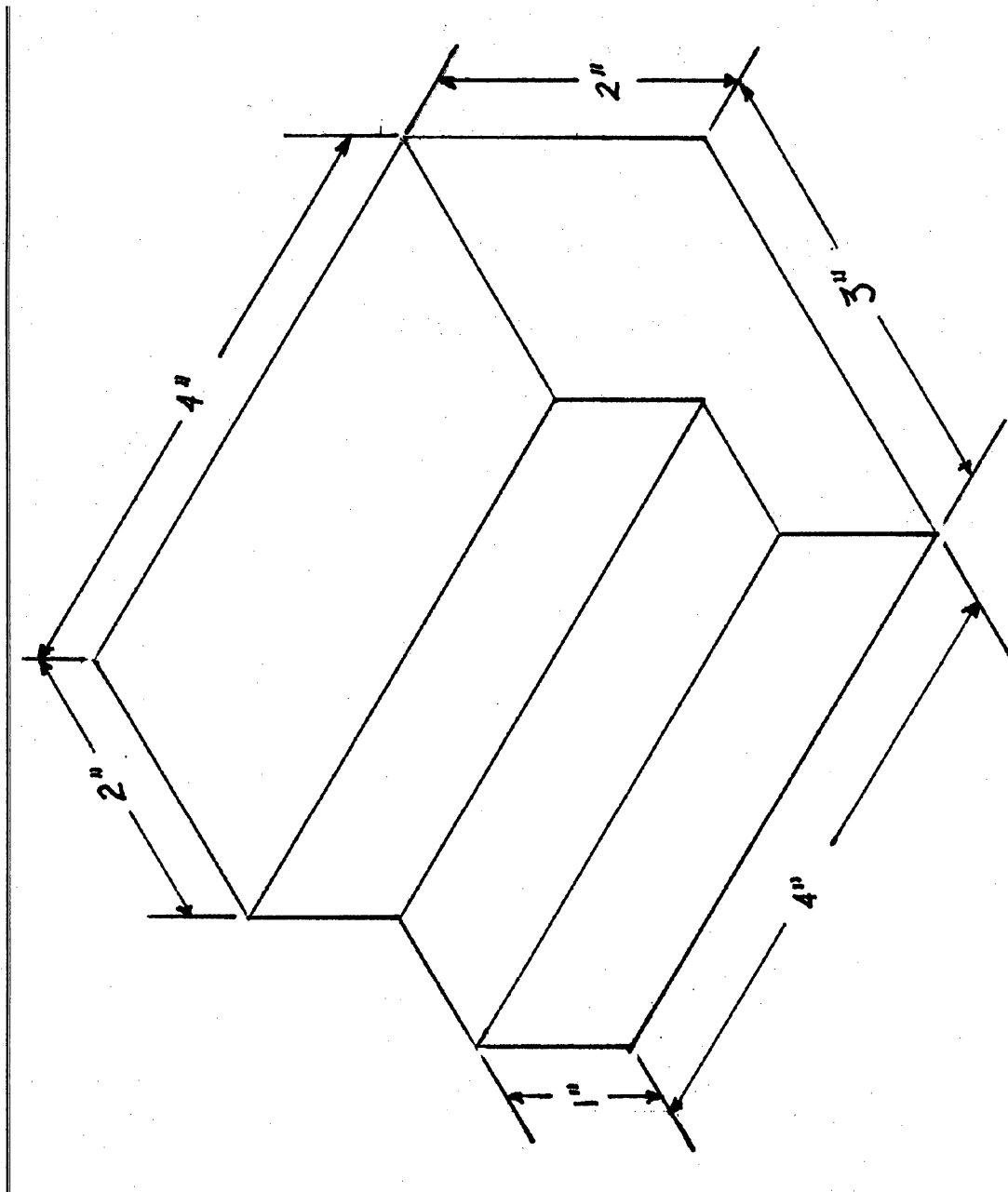

Difficult Three-Dimensional Student Drawing

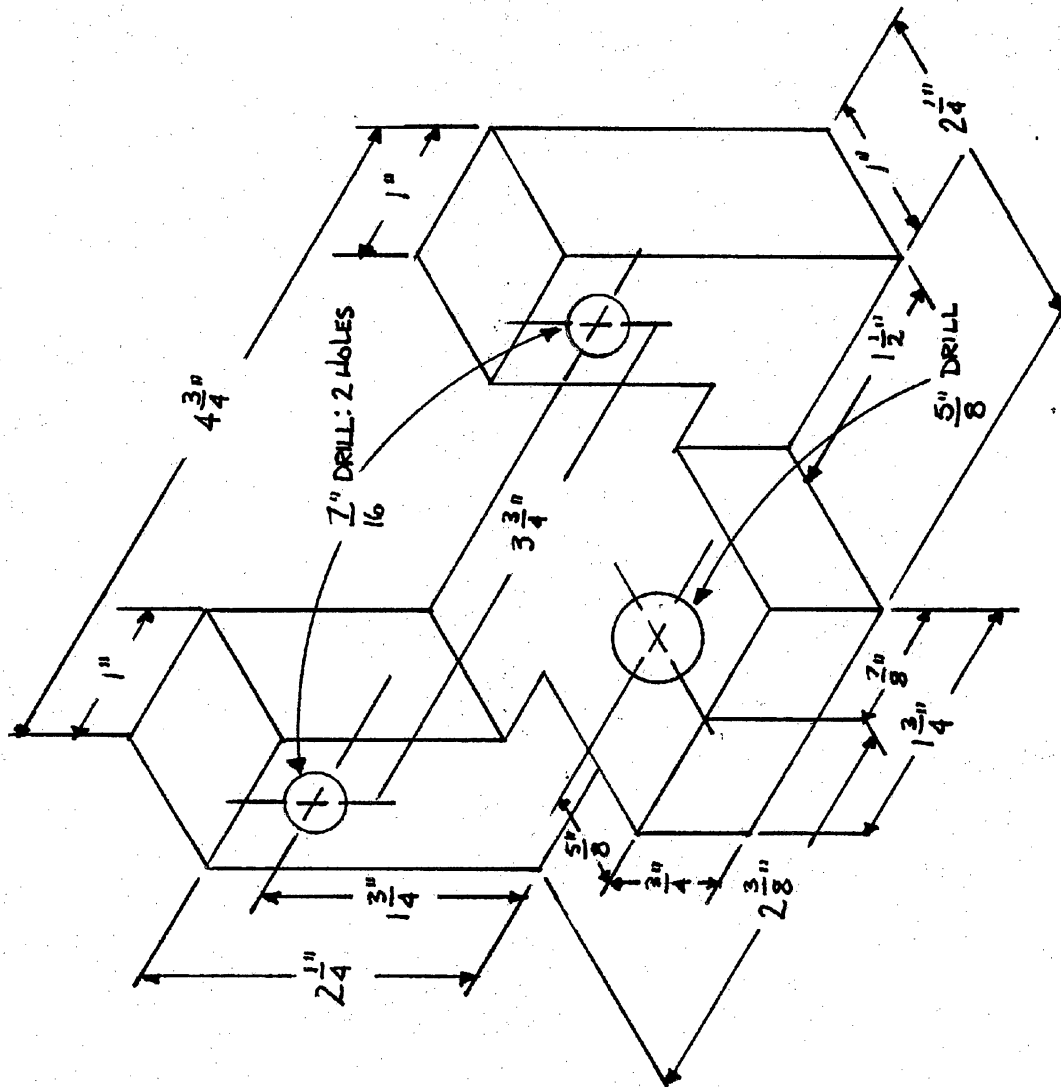

**UNIT TWO**

**Seventh Grade Drafting**



## **Introduction**

The seventh-grade drafting curriculum is the second unit in a series of three. The primary focus of this curriculum is to introduce to the students, and have them successfully implement, the 1/4" scale in the design of house floor plans. Students will begin with a short review on printing letters and numbers (the same Letters and Numbers printing assignment as given out in sixth grade). Handouts will be given. After reviewing the handouts in class, quizzes and tests will be administered to identify their understanding of the 1/4" scale. Answer sheets will follow all quizzes and tests. A series of handouts, which highlights information pertinent to the construction and design of homes, are distributed. The first drawing exercise for the students is a negative-drawing exercise, white pencil on black paper. The feature of this exercise is two house elevations, north and south. Students will complete two (2) house floor plans. The detail of the floor plans will be limited to the handouts and information given in class. Because the paper used by the students for their floor plans is large, 18" x 14", an example of what the students draw will be introduced in the document.

Upon the completion of seventh grade drafting, students will be able to:

- Print letters and numbers correctly.
- Understand and correctly use Drafting Terminology.
- Display an understanding and ability to measure using the 1/4" scale.
- Successfully draw limited-detail floor plans for houses.

## 1/4" Scale

Every inch has four (4) quarters

Every quarter = 4/16"

Every quarter = one (1) foot

Every inch = four (4) feet

In the 1/4" scale there are eight (8) eighths

Every eighth = six (6) inches

Example:

3 3/4" = How many feet in the 1/4" scale?

Remember: Every inch = 4'

If there are three (3) inches then there are 12'

If each 1/4" = one (1) foot; then 3/4 = 3'

When you add the measurements together you find that

3 3/4" in the 1/4" scale = fifteen (15) feet... 15'

4 3/8" = How many feet in the 1/4" scale?

Remember: Every inch = 4'

If there are four (4) inches then there are 16'

If each eighth equals six (6) inches; then 3/8 = 1'6"

Here's why: In 3/8" there are three (3) 1/8" increments Each eighth is = to 6"

In 3/8" there are three (3) 1/8" increments which = 6" three times which = 18" which = 1'6"

Therefore, 4 3/8" in the 1/4" scale, when adding all the measurements, would = 17'6"

## 1/4" Scale Guide Sheet

1. In the 1/4" scale, (Remember 1/4" = 4/6"), 1/4" = 1' OR 12"
2. In a standard ruler, based on 12" = 1', there are four (4) quarters in one (1) inch, therefore;
3. If YOU are measuring with the standard ruler, and you are converting standard inches to 1/4" scale, one (1) standard inch would equal four (4) feet in the 1/4" scale.
4. If one (1) inch equals 4' then two (2) inches would equal 8', three (3) inches would equal 12'.
5. every inch would be multiplied by four (4) to give you the amount of 1/4" scale feet.
6. if 1/4" = 1' then 1/8", (2/16"), or half of 1/4", would = 6".
7. if 1/4" = 1' then 1/16", Or one-fourth of 1/4", would = 3".
8. If a measurement, using the standard ruler, was 10 1/2", the converted 1/4 scale measurement would be 42' 10" x 4' per inch = 40, 1/2" x 4' per inch = 2", 40' + 2' = 42'.

Example #2... 6 1/8" = 24'6"  
6" x 4' per inch = 24', 1/8" = 6", 24' + 6" = 24'6"

example #3... 8 3/8" = 33'6"  
8" x 4' per inch = 32', now for the 3/8", each 1/8" = 6", so 3/8" would = 18", just add that to the 32 and you would get the 33'6", or since 3/8" = 1/4" (2/8" = 1/4") + 1/8", you would have one (1) more foot and 6" and you would add that to the 32' to get the answer of 33'6".

### 1/4" Scale: Quiz

DO NOT WRITE ON THIS QUIZ

1. Three inches equals how many feet?
2. Six inches equals how many feet?
3. Sixty feet equals how many inches?
4. Twenty-four feet equals how many inches?
5. Eight and three-sixteenth inches equals how many feet?
6. Four and five-eighth inches equals how many feet?
7.  $7 \frac{4}{16}$ " equals how many feet?
8.  $5 \frac{9}{16}$ " equals how many feet?
9.  $9 \frac{3}{8}$ " equals how many feet?
10.  $10 \frac{7}{8}$ " equals how many feet?

**1/4" Scale: Quiz Answer Sheet**

1. 12
2. 24
3. 15
4. 6
5. 32' 9"
6. 18' 6"
7. 29' 9"
8. 22' 3"
9. 37' 6"
10. 43' 6"

### **Fractional Inch Top And Bottom Directions: 1/4" Scale Quiz**

On top, locate the measurement on the ruler and convert it to the 1/4" scale. Be sure to reduce whenever possible.

On the bottom, measure the line segment and convert it to the 1/4" scale.

Write the answers on your own paper.

## Fractional Inch Top and Bottom: Quiz

Determine the length of each of the lettered dimension lines on the scale below. Letter each dimension in the corresponding spaces at the right. Letter A is given as an example. Add arrowheads to the ends of the dimension lines.

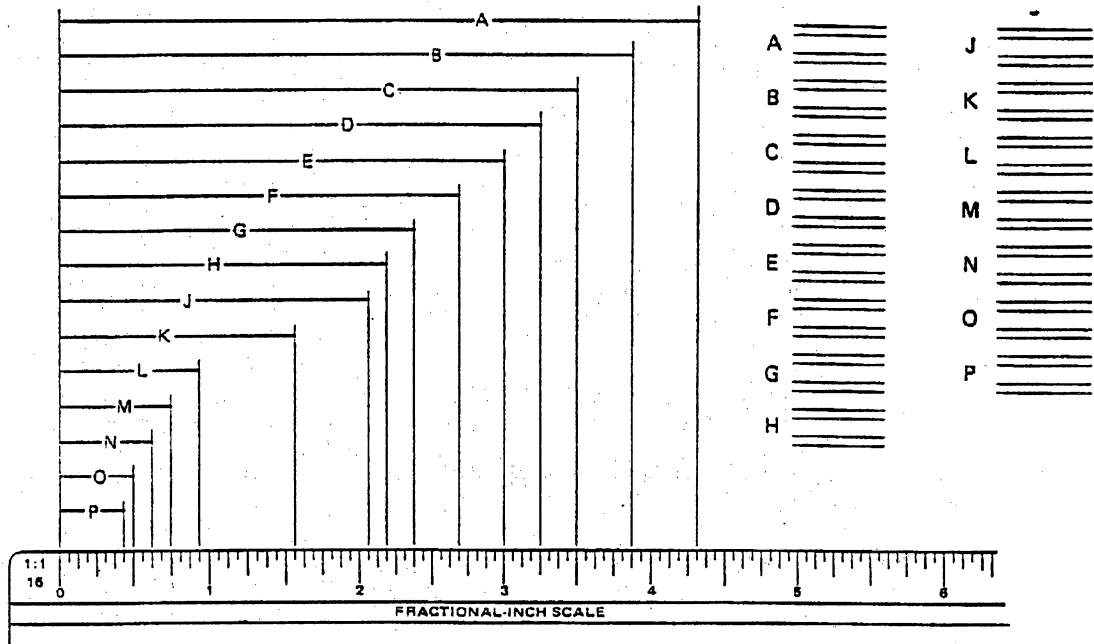

Using a full-size fractional-inch scale, measure each of the lettered lines in the figure below. Record the length of each in its corresponding space at the right. Measure all lines to the nearest 16th of an inch.

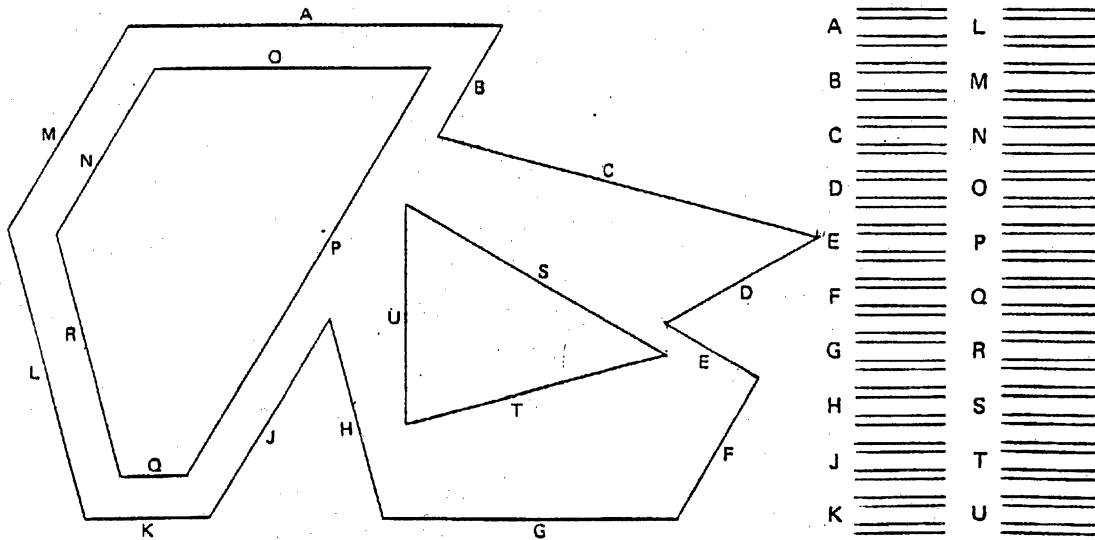

<b>THE USE AND CARE OF DRAFTING EQUIPMENT</b>	DRAWN BY	DATE	DWG NO.
---	----------	------	---------



## Fractional Inch: Quiz Answer Sheet

	TOP		BOTTOM
A.	17' 3"	A.	10'      OR    10' 3"
B.	15' 6"	B.	3' 6"
C.	14'	C.	10' 9"   OR   11'
D.	13"	D.	4' 9"   OR   5'
E.	12'	E.	3'
F.	10' 9"	F.	4' 6"
G.	9' 6"	G.	8'
H.	8' 9"	H.	5' 6"   OR   5' 9"
J.	8' 3"	J.	6' 3"
K.	6' 3"	K.	3' 3"   OR   3' 6"
L.	3' 9"	L.	8' 3"
M.	3'	M.	6'      OR    6' 3"
N.	2' 6"	N.	5' 3"   OR   5' 6"
O.	2'	O.	7' 3"   OR   7' 6"
P.	1' 9"	P.	13'
		Q.	1' 9"
		R.	7'
		S.	8' 3"   OR   8' 6"
		T.	7' 3"   OR   7' 6"
		U.	6'      OR    6' 3"

## Framing-Doors-Windows

### Doors:

Doors are given measurements that represent width of the door opening.

Ex. #1 A 2° door would be 24" wide, A 3° door would be 36" wide.

### Windows:

When listing the measurements of a window, always give the width first.

Ex. #1 A 6° - 2° window would measure six(6)feet wide and two (2)feet high

Ex. #2 A 3° - 5° window would measure three (3) feet wide and five (5) feet high

### Roofs and Slopes (Pitches):

The Slope or Pitch of a roof is described as the "rise over run" (rise/run). Run is the horizontal distance covered by a roof. The run is always expressed in units of 12". Therefore, the pitch shows the proportion of the rise to 12".

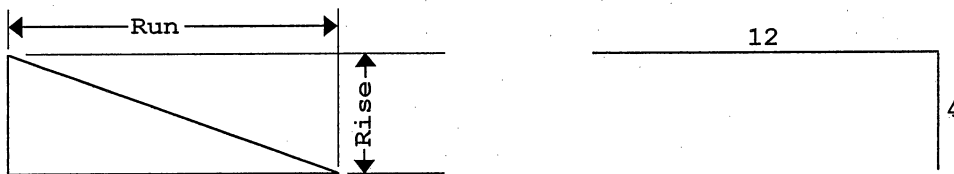

### Walls:

Most walls on the exterior of a house are framed with studs that are either 2x4 or 2x6 studs. 2x4 studs are framed at 16" on center. That means that from one stud to another, it is 16" from one center to another. 2x6 studs are framed at 24" on center. Since 2x6's are thicker, they can be framed farther apart.

### Shear Paneling:

Shear paneling is the use of 4x8 sheets of plywood on the exterior of the framed house. The purpose of the paneling is to reinforce the structure, to give it more strength and stability.

### Cut and Stack:

This is a method of "trussing" that is used instead of conventional trussing.

### Sale of Lumber:

Lumber is sold by the "board foot". The following is an example of how to order lumber. BF = T(in.) x W(ft.) x L(ft.)

## Framing-Doors-Windows: Quiz

DO NOT WRITE ON THIS QUIZ

1. What is the width in inches of a:  

$2^0$	door
$3^2$	door
$2^4$	door
$3^6$	door
$2^8$	door
  
2. In the following examples, when measuring a window which measurement is the length, and which measurement is the height?  

A.	$6^0 - 3^0$
b.	$3^0 - 5^0$
  
3. What is meant by a 4" and 12" roof pitch or slope?
  
4. What does framing at... 16" on center... mean?
  
5. How far apart are 2x4 studs spaced in the general construction of a house?
  
6. How far apart are 2x6 studs spaced in the general construction of a house?
  
7. What is the primary purpose for "shear Paneling"?
  
8. What does it mean to cut and stack a roof?
  
9. Lumber is sold by the \_\_\_\_\_ foot.
  
10. Write down the formula for figuring "board feet" when ordering

**Framings-Doors-Windows: Quiz Answer Sheet**

1. A. = 24" B. = 38" C. = 28" D. = 42" E. = 32"
2. A. = 6 = L 3 = H B. 3 = L 5 = H
3. EVERY 12" OF RUN EQUALS 4" OF RISE
4. STUDS ARE SET UP AT 16" ON CENTER
5. 16"
6. 24"
7. TO GIVE STRENGTH TO THE EXTERIOR WALLS
8. INSTEAD OF MANUFACTURED TRUSSES, LUMBER IS CUT TO  
FORM A ROOF.
9. BOARD
10. BF = T(IN.) X W(FT.) X L(FT.)

## Electrical Symbols

### Lighting Outlets:

 Surface individual fluorescent fixture

 Recessed individual fluorescent fixture

 Surface continuous - row fluorescent fixture

 Recessed continuous - row fluorescent fixture

 Surface exit light

 Recessed exit light

 Blanked outlet

 Junction box

### Receptacle Outlets:

 Single receptacle outlet

 Duplex receptacle outlet

 Triplex receptacle outlet

 Quadruplex receptacle outlet

 Range outlet

 Fan hanger receptacle

### Switch Outlets:

 Single-pole switch

 Three-way switch

 Door switch

 Circuit breaker switch

### Signaling-system outlets-residential occupancies:

 TV outlet

 Pushbutton

 Bell

 Chime

 Electric door opener

### Circuiting:

 Wiring concealed in ceiling or wall

 Wiring concealed in floor

 Wiring exposed

## **Electrical Symbols: Test**

### **Lighting Outlets:**

- Surface individual fluorescent fixture
- Recessed individual fluorescent fixture
- Surface continuous - row fluorescent fixture
- Recessed continuous - row fluorescent fixture
- Surface exit light
- Recessed exit light
- Blanked outlet
- junction box

### **Receptacle Outlets:**

- Single receptacle outlets
- Duplex receptacle outlets
- Triplex receptacle outlets
- Quadruplex receptacle outlets
- Range outlets
- Fan hanger receptacle

### **Switch Outlets:**

- Single-pole switch
- Three-way switch
- Door Switch
- Circuit breaker switch

### **Signaling-system outlets-residential occupancies:**

- TV outlet
- Pushbutton
- Bell
- Chime
- Electric door opener

### **Circuiting:**

- Wiring concealed in ceiling or wall
- Wiring concealed in floor
- wiring exposed

Electrical Symbols: Test Answer Sheet

Lighting Outlets:

 Surface individual fluorescent fixture

 Recessed individual fluorescent fixture

 Surface continuous - row fluorescent fixture

 Recessed continuous - row fluorescent fixture

 Surface exit light

 Recessed exit light

 Blanked outlet

 Junction box

Receptacle Outlets:

 Single receptacle outlet

 Duplex receptacle outlet

 Triplex receptacle outlet

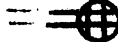
 Quadruplex receptacle outlet

 Range outlet

 Fan hanger receptacle

Switch Outlets:

 Single-pole switch

 Three-way switch

 Door switch

 Circuit breaker switch

Signaling-system outlets-residential occupancies:

 TV outlet

 Pushbutton

 Bell

 Chime

 Electric door opener

Circuiting:

 Wiring concealed in ceiling or wall

 Wiring concealed in floor

 Wiring exposed

## **Elements of a House**

**Major Elements:** Foundations (including footings), wall, partitions, floors, roof, doorway, windows, stairs, fireplaces, and chimney.

**Structural Elements:** Most important ... columns, beams, lintels, and trusses.

**Plans:** Form the most important part of the architectural drawings. Dimensions form the most important feature of the plan. A small-scale plan is called a plot plan.

**Elevations & Sections:** Vertical shapes and sizes of buildings are defined by elevations and sections. Elevation views identify different materials or elements including siding, stonework, brick, roof shingles, metal flashing, glass and glass blocks, cement and concrete, downspouts, and gutters.

**Architectural Details:** Next to the plans the most important part are the details.

**Principal Details:** Footing and foundations, wall sections, floor and ceiling framing, door, chimneys and heating tracts, stairs, roof framing and roofs.

**Footings & Foundation:** Stability depends on the strength, size, and quality of the footing. The size of the footings depends on the load that are to carry. In cases of flat roofs and of steep roofs, a possible snow and wind load factor may be factored in. Footings support the foundation walls which in turn support the ground floor framing and the structure.

**Wall Sections:** Most common types of residential construction are the frame wall, brick veneer wall, brick and concrete wall, and concrete block wall.

**Door & Windows:** If made of wood, doors and windows are classified as mill work. Manufacturer's standard terms for windows and door are double-hung windows, casement sash, solid wood door, hollow-core door, and solid-core door.

**Stairs:** Interior and exterior stairways are made of, wood, steel, concrete or combinations of these materials.

**Misc. Structural Details:** In many cases old brick residential buildings require steel skeleton and steel roof framing.

**Chimneys & heating Ducts:** Included in this category of details are chimneys, stacks for ventilation, fireplaces, and outdoor ovens and grills.

**Built-in Installations:** Common built-in products are microwave ovens, bookcases, library shelves, and range tops.

**Working Drawings:** They represent the final stage of the architect's work. They include plan, elevations, sections and details and are usually drawn at a scale of 1/4" = 1'.



## Elements of a House: Test

Footings & Foundation	A	They represent the final stage of the architect's work. They include plan, elevations, sections and details and are usually drawn at a scale of 1/4" = 1'.
Major Elements	B	Most common types of residential construction are the frame wall, brick veneer wall, brick and concrete wall, and concrete block wall.
Working Drawings	C	If made of wood, doors and windows are classified as mill work. Manufacturer's standard terms for windows and door are double-hung windows, casement sash, solid wood door, hollow-core door, and solid-core door.
Built-in Installations	D	Next to the plans the most important part are the details.
Stairs	E	Foundations (including footings), wall, partitions, floors, roof, doorway, windows, stairs, fireplaces, and chimney.
Chimneys & heating Ducts	F	Most important ... columns, beams, lintels, and trusses.
Structural Elements	G	Common built-in products are microwave ovens, bookcases, library shelves, and range tops.
Wall Sections	H	Form the most important part of the architectural drawings. Dimensions form the most important feature of the plan. A small-scale plan is called a plot plan.
Misc. Structural Details	I	Interior and exterior stairways are made of, wood, steel, concrete or combinations of these materials.
Plans	J	Included in this category of details are chimneys, stacks for ventilation, fireplaces, and outdoor ovens and grills.
Elevations & Sections	K	In many cases old brick residential buildings require steel skeleton and steel roof framing.
Door & Windows	L	Footing and foundations, wall sections, floor and ceiling framing, door, chimneys and heating tracts, stairs, roof framing and roofs.
Architectural Details	M	Stability depends on the strength, size, and quality of the footing. The size of the footings depends on the load that are to carry. In cases of flat roofs and of steep roofs, a possible snow and wind load factor may be factored in. Footings support the foundation walls which in turn support the ground floor framing and the structure.
Principal Details	N	Vertical shapes and sizes of buildings are defined by elevations and sections. Elevation views identify different materials or elements including +siding, stonework, brick, roof shingles, metal flashing, glass and glass blocks, cement and concrete, downspouts, and gutters.

**Elements of House: Test Answer Sheet**

1. M
2. E
3. A
4. G
5. I
6. J
7. F
8. B
9. K
10. H
11. N
12. C
13. D
14. L

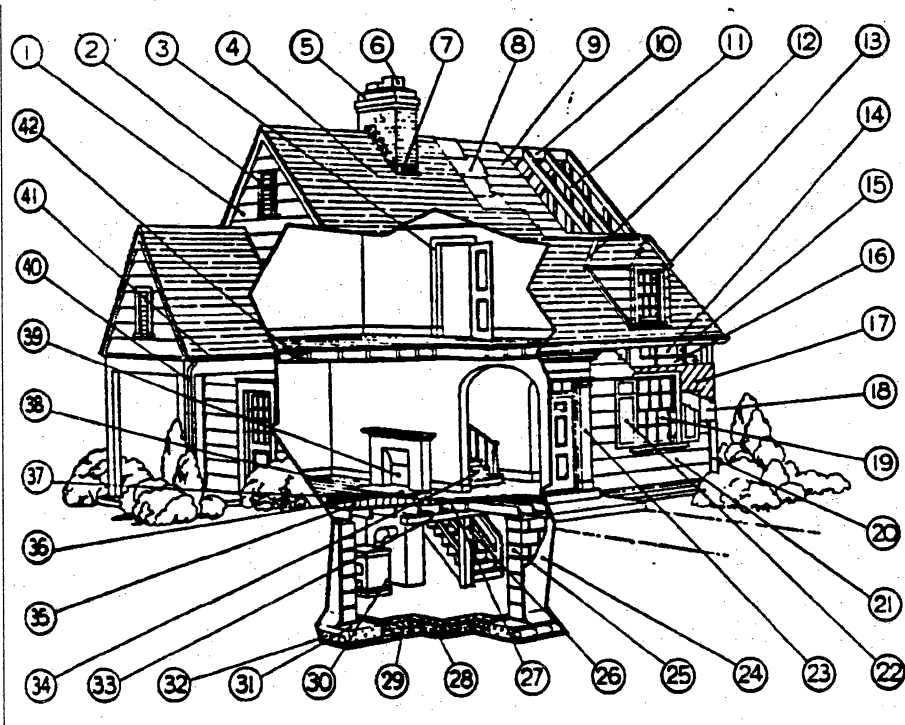

- |                           |                     |
|---------------------------|---------------------|
| 1. Gable end              | 21. Siding          |
| 2. Louver                 | 22. Shutters        |
| 3. Interior trim          | 23. Exterior trim   |
| 4. Shingles               | 24. Waterproofing   |
| 5. Chimney cap            | 25. Foundation wall |
| 6. Flue linings           | 26. Column          |
| 7. Flashing               | 27. Joists          |
| 8. Roofing felt           | 28. Basement floor  |
| 9. Roof sheathing         | 29. Gravel fill     |
| 10. Ridge board           | 30. Heating plant   |
| 11. Rafters               | 31. Footing         |
| 12. Roof valley           | 32. Drain tile      |
| 13. Dormer window         | 33. Girder          |
| 14. Interior wall finish  | 34. Stairway        |
| 15. Studs                 | 35. Subfloor        |
| 16. Insulation            | 36. Hearth          |
| 17. Diagonal sheathing    | 37. Building paper  |
| 18. Sheathing paper       | 38. Finish floor    |
| 19. Window frame and sash | 39. Fireplace       |
| 20. Corner board          | 40. Downspout       |
|                           | 41. Gutter          |
|                           | 42. Bridging        |

Elements of a House

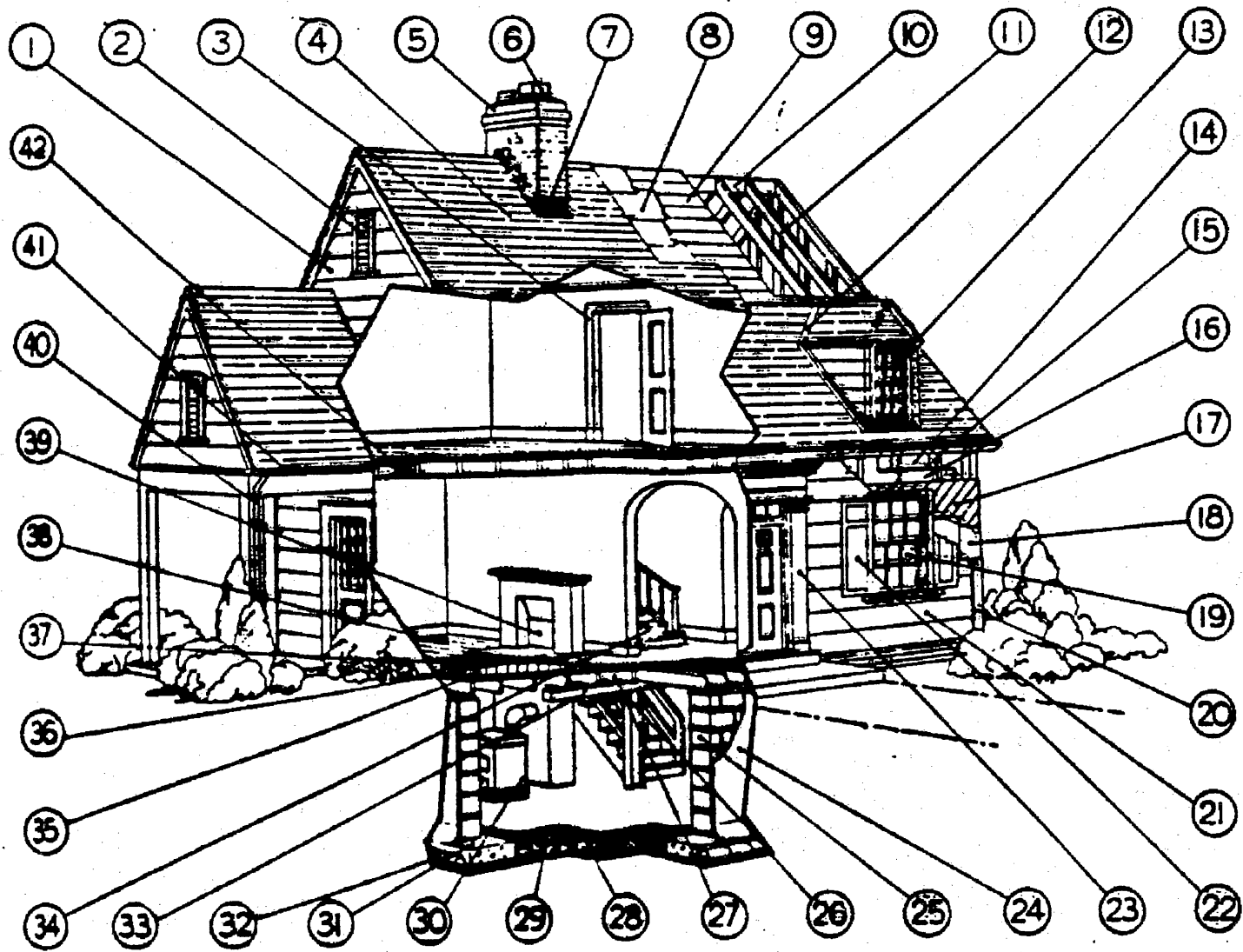

Elements of a House-Quiz

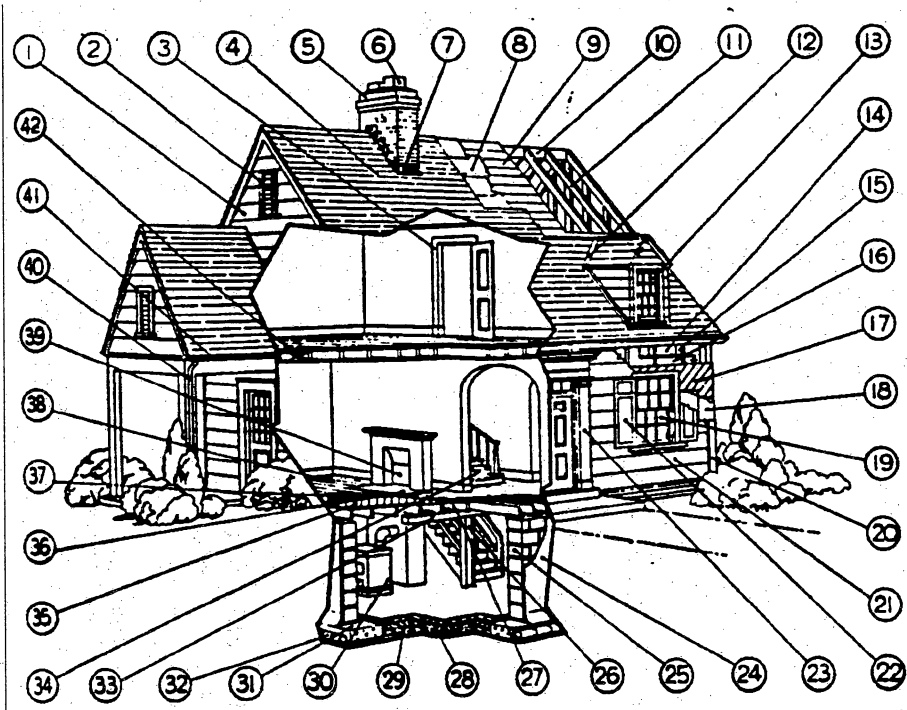

- |                           |                     |
|---------------------------|---------------------|
| 1. Gable end              | 21. Siding          |
| 2. Louver                 | 22. Shutters        |
| 3. Interior trim          | 23. Exterior trim   |
| 4. Shingles               | 24. Waterproofing   |
| 5. Chimney cap            | 25. Foundation wall |
| 6. Flue linings           | 26. Column          |
| 7. Flashing               | 27. Joists          |
| 8. Roofing felt           | 28. Basement floor  |
| 9. Roof sheathing         | 29. Gravel fill     |
| 10. Ridge board           | 30. Heating plant   |
| 11. Rafters               | 31. Footing         |
| 12. Roof valley           | 32. Drain tile      |
| 13. Dormer window         | 33. Girder          |
| 14. Interior wall finish  | 34. Stairway        |
| 15. Studs                 | 35. Subfloor        |
| 16. Insulation            | 36. Hearth          |
| 17. Diagonal sheathing    | 37. Building paper  |
| 18. Sheathing paper       | 38. Finish floor    |
| 19. Window frame and sash | 39. Fireplace       |
| 20. Corner board          | 40. Downspout       |
|                           | 41. Gutter          |
|                           | 42. Bridging        |

Elements of a House - Answer Sheet

NORTH ELEVATION

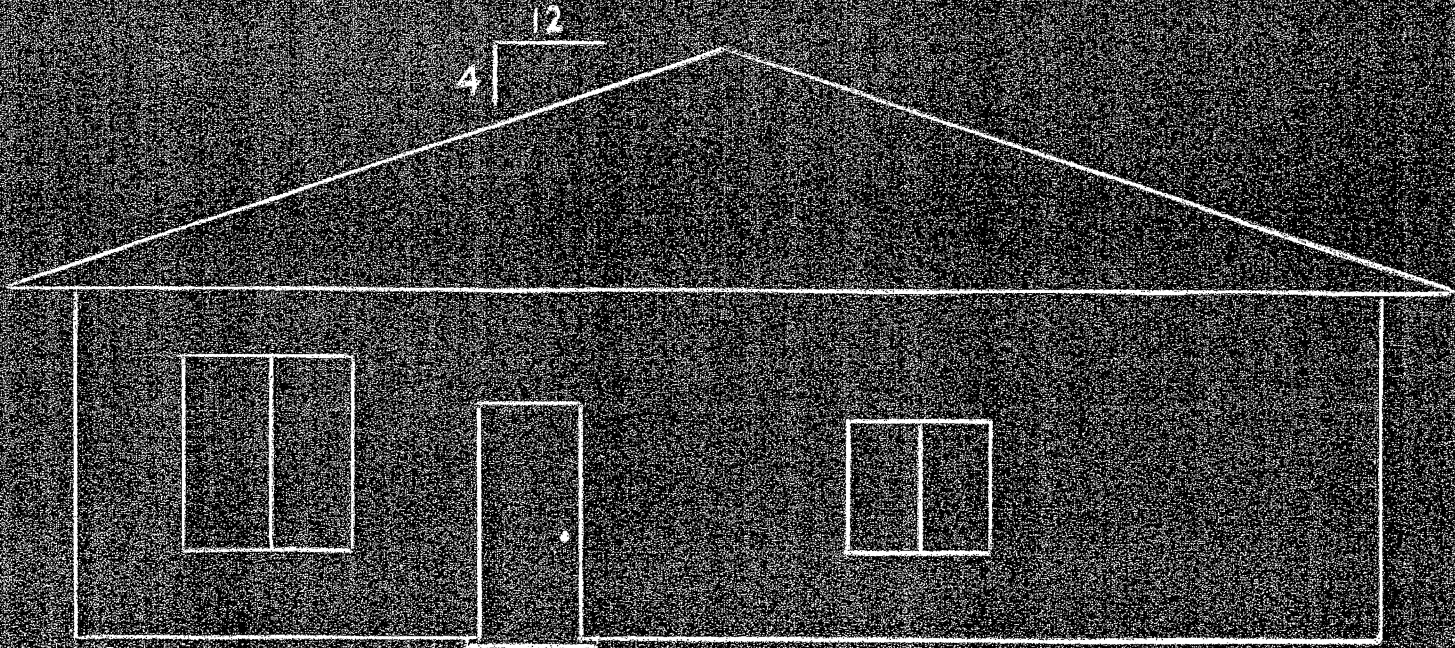





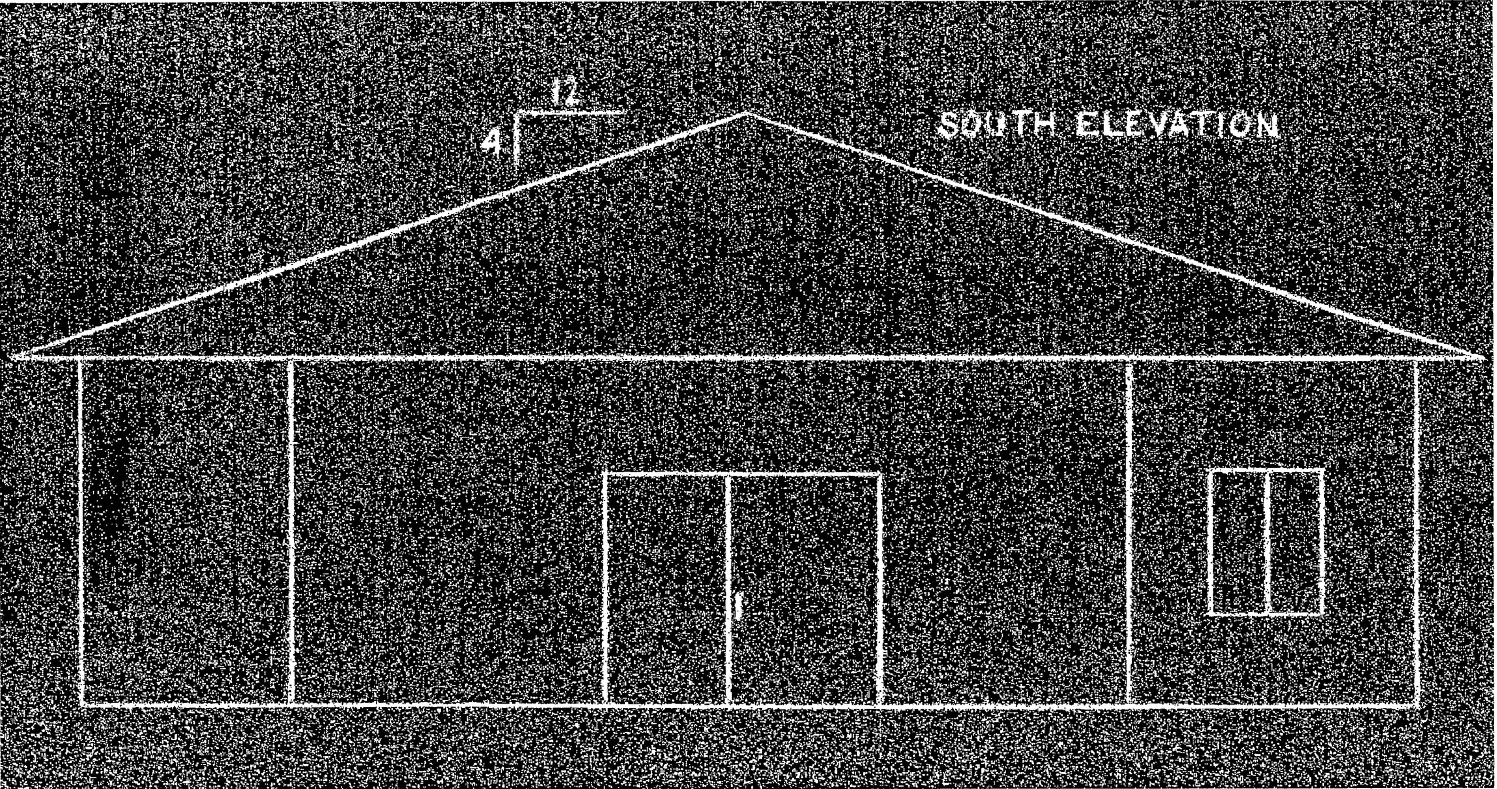



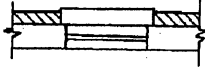

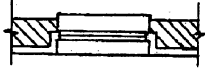

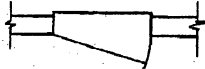



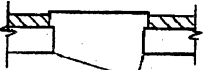
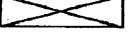

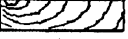

North Elevation Negative Drawing-House

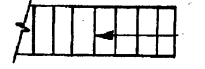
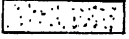
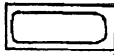
South Elevation Negative Drawing-House

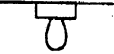

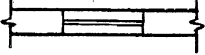
## Architectural Symbols

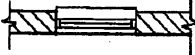
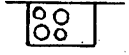
	<b>BRICK</b>		<b>WINDOW IN A BRICK VENEER WALL</b>
	<b>CONCRETE BLOCK</b>		<b>WINDOW IN A BRICK WALL WITH PLASTER</b>
	<b>CLAY TILE</b>		<b>DOOR IN A FRAME WALL</b>
	<b>CONCRETE</b>		<b>DOOR IN A BRICK WALL</b>
	<b>STONE</b>		<b>DOOR IN A BRICK VENEER WALL</b>
	<b>ROUGH WOOD</b>		<b>DOOR IN A BRICK WALL WITH PLASTER</b>
	<b>FINISHED WOOD</b>		<b>FIREPLACE</b>
	<b>STEEL</b>		<b>CHIMNEY</b>
	<b>FILL</b>		<b>STAIRS</b>
	<b>SAND</b>		<b>BUILT-IN TUB</b>
	<b>GRAVEL</b>		<b>WATER CLOSET</b>
	<b>INSULATION</b>		<b>LAVATORY</b>
	<b>WINDOW IN A FRAME WALL</b>		<b>COUNTER SINK</b>
	<b>WINDOW IN A BRICK WALL</b>		<b>RANGE</b>



# Floor Plan in Three Stages

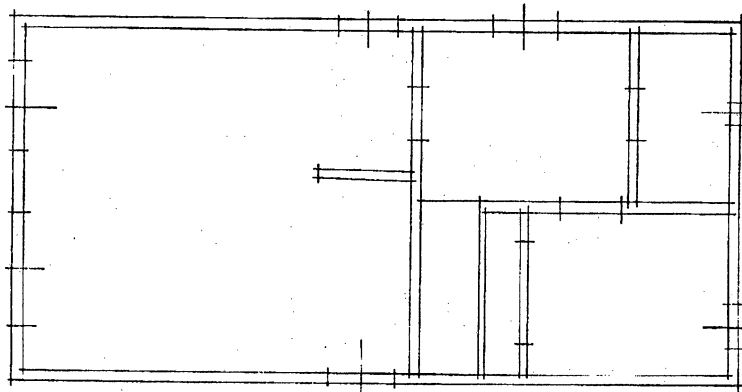

- BLOCK IN OUTLINE
- LAY OUT PARTITIONS
- LOCATE DOORS
- LOCATE WINDOWS

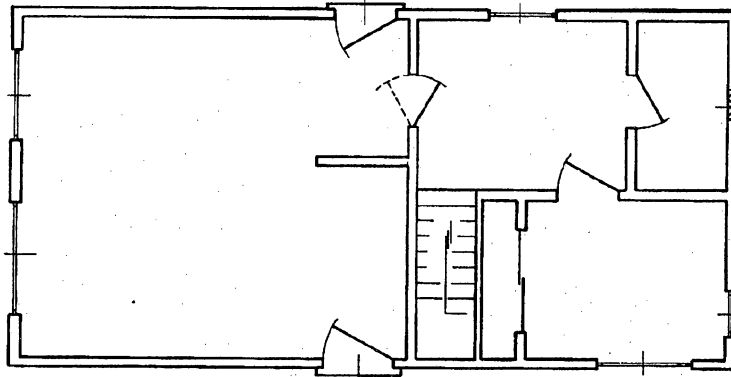

- DARKEN LINES
- WINDOW SYMBOLS
- DOOR SYMBOLS
- STAIRWELL
- ERASE LAYOUT LINES

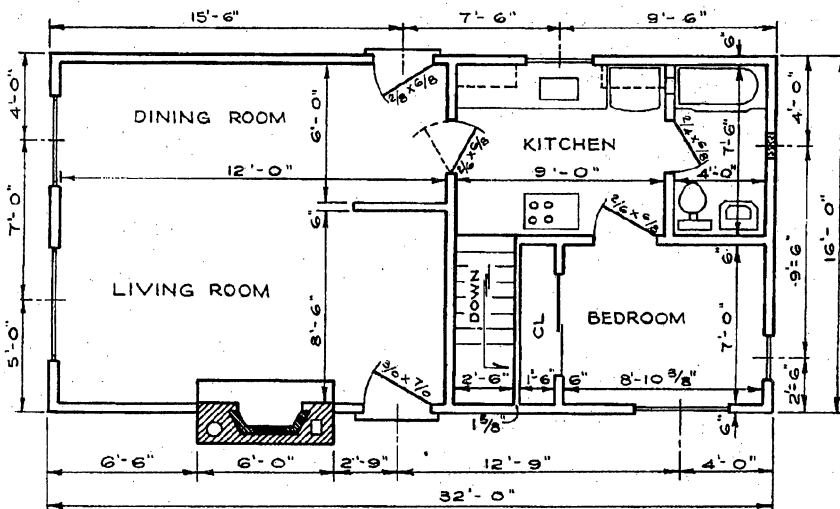

- BATH FIXTURES
- KITCHEN FIXTURES
- FIREPLACE
- DIMENSIONS
- LETTERING
- ERASE GUIDELINES

### Three Bedroom Floor Plan

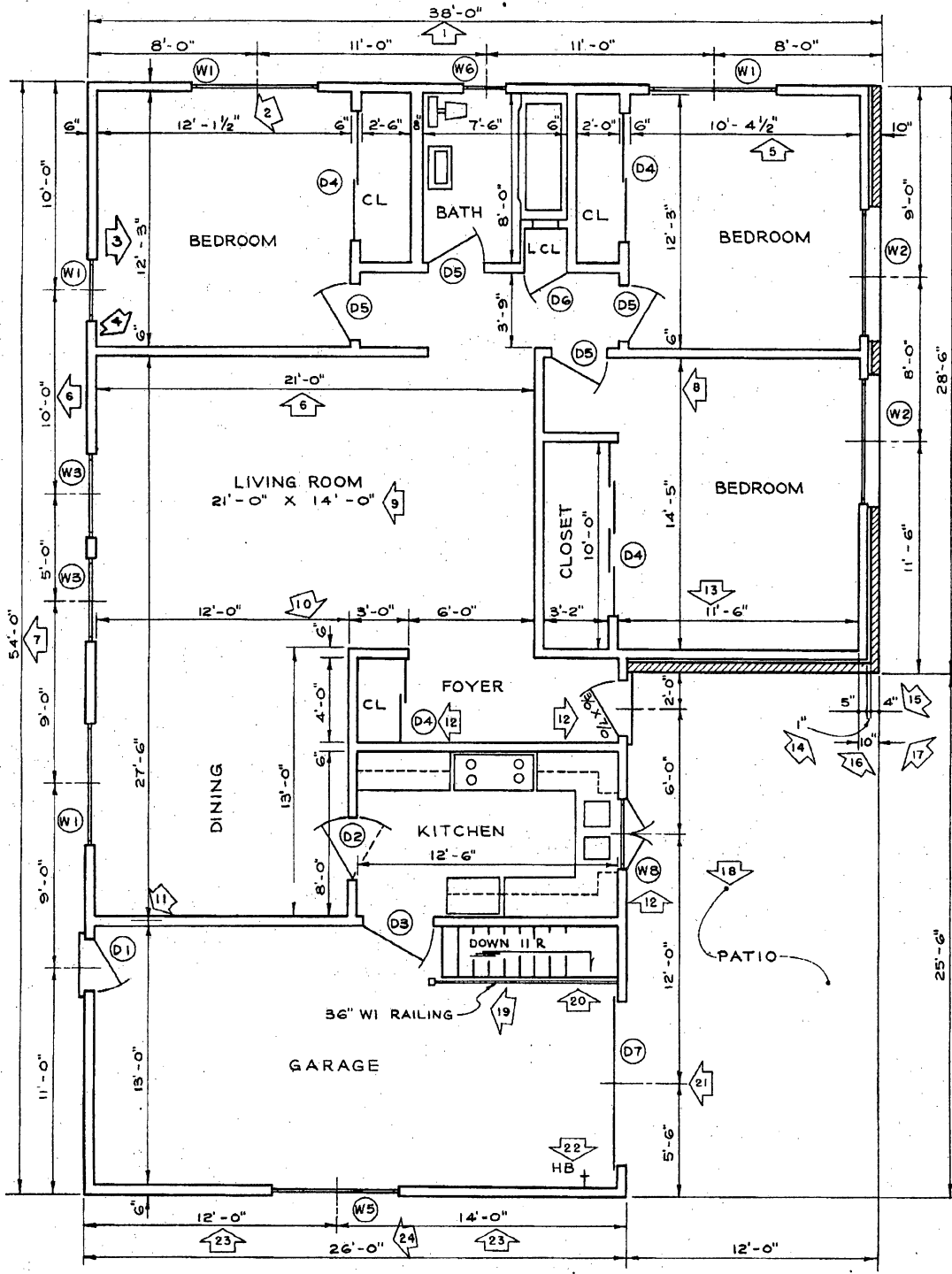

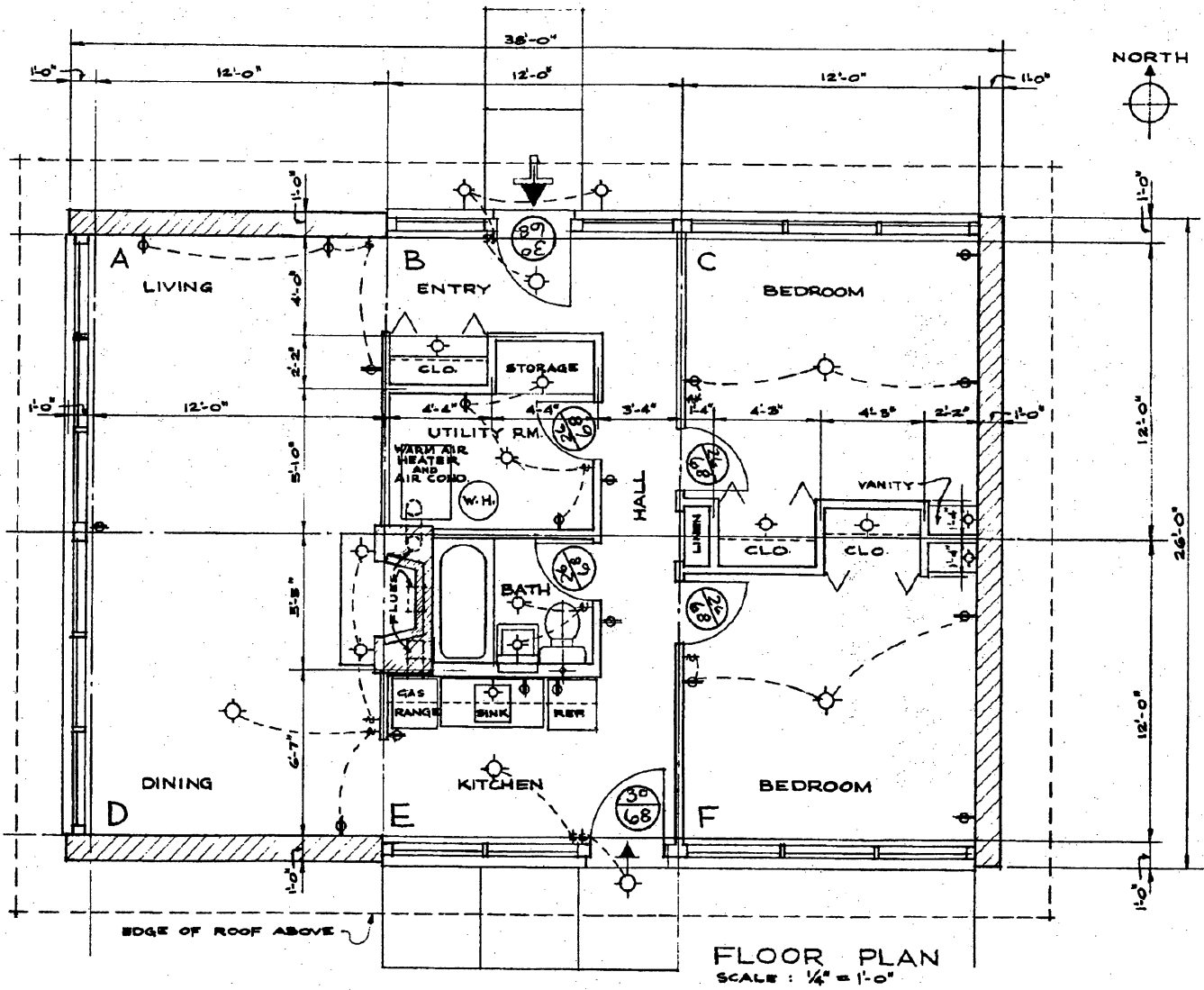

Two Bedroom Floor Plan

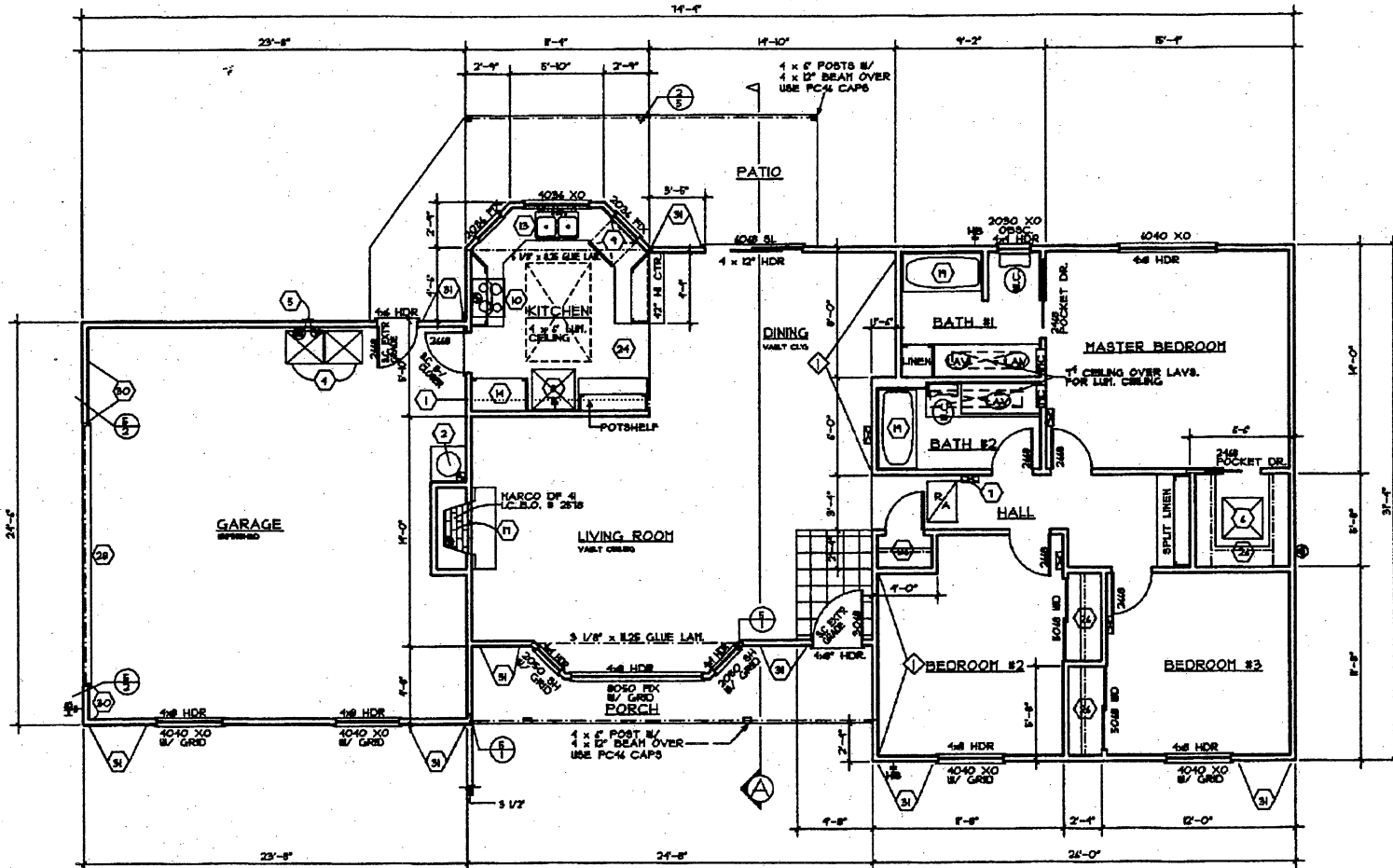

FLOOR PLAN

LIVING AREA 1470 SQ. FT.

SCALE 1/4" = 1'-0"

1470 Student Floor Plan

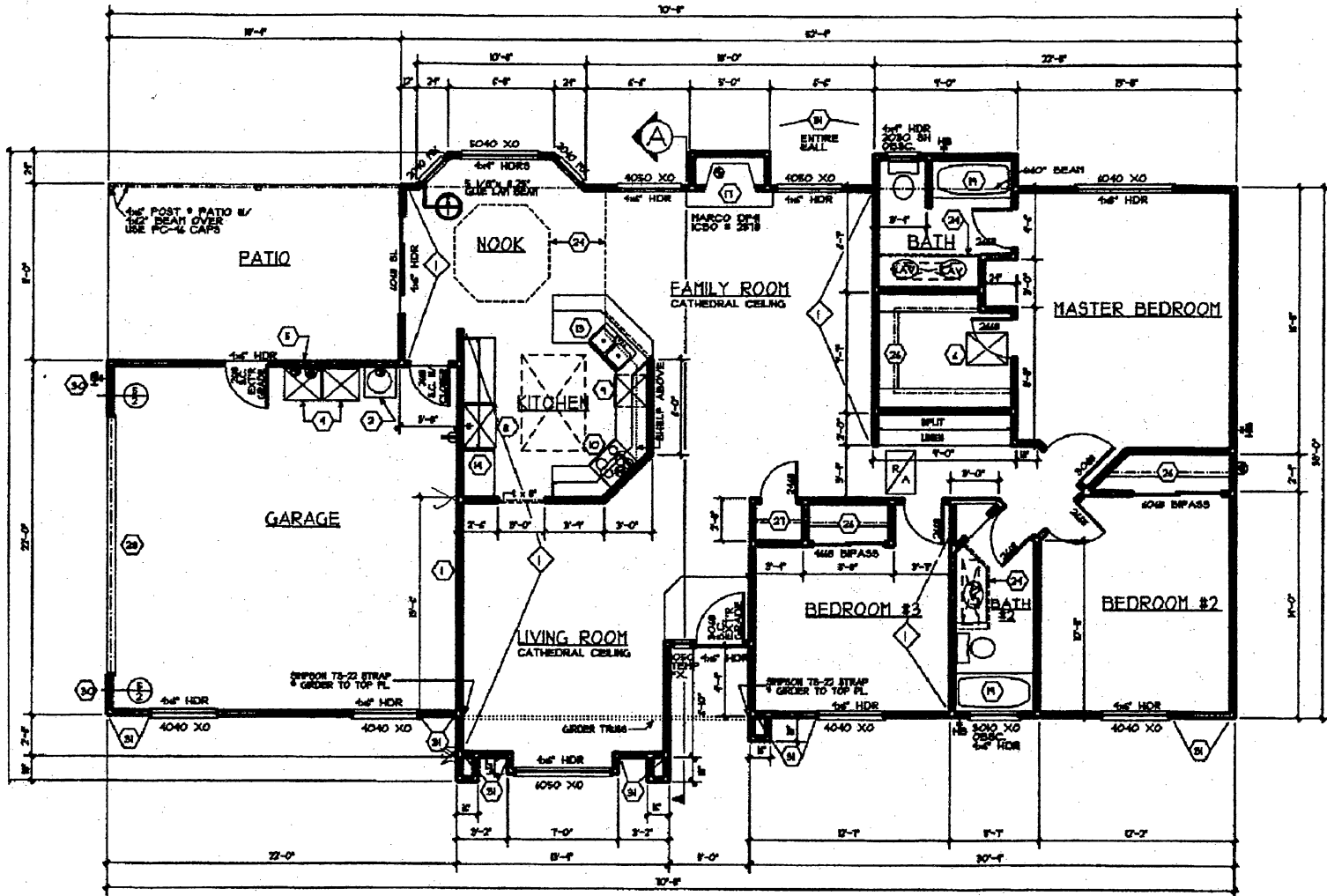

1698 Student Floor Plan

**FLOOR PLAN** LIVING AREA 1698 SQ. FT. SCALE 1/4" = 1'-0"

**UNIT THREE**

**Eighth Grade Drafting**

## **Introduction**

The eighth grade-drafting curriculum is the third in a series of three curricula.

The eighth grade curriculum again begins with a short capital Letters and Numbers printing assignment.

The focus then emphasizes computers and the introduction to CAD (Computer Assisted Drawing). The majority of students have good computer skills and the knowledge of how to access files, save, and retrieve files. The program used is called, Home Design 3D, and is a PC (Personal Computer) program. It is an intermediate level CAD program, which emphasizes the design of house floor plans. The program includes accessories, which allows students to dimension all aspects of the plan, decorate, landscape, and also calculate purchasing and financing costs. All floor plans must include these minimum requirements:

1. Three bedrooms
2. Two bathrooms, one a master bathroom.
3. A family room.
4. A living room
5. A kitchen.
6. A dining room.

7. Doors, interior and exterior.

8. Windows.

9. Garages are not required.

The instructor's method for grading the drawings is more subjective than objective. The ability level of the students will vary, even with the use of a computer. The instructor emphasizes that all requirements for each drawing be met. It is the instructor's opinion that students, through the repetitive and similar nature of all four drawing assignments, progress in ability and drawing presentation.

Upon the completion of the eighth grade-drafting curriculum, students will be able to:

- Print letters and numbers correctly.
- Display a working ability on a computer.
- Successfully design eight (8) floor plans;

Two (2) with exterior and interior walls and room identification,

Two (2) with exterior and interior walls, exterior and interior doors, windows, and room identification,

Two (2) with exterior and interior walls, exterior and interior doors, windows, dimensions for all walls,



door and window sizes, door and window schedule, and room identification, and

Two (2) with exterior and interior walls, exterior and interior doors, windows, interior furnishing, landscaping, and room identification.

One example of each of the aforementioned designs are included in this project.

Though it is not required, students are encouraged to include a purchase price and an amortized loan with monthly payments with the final drawing.

Floor Plan #1

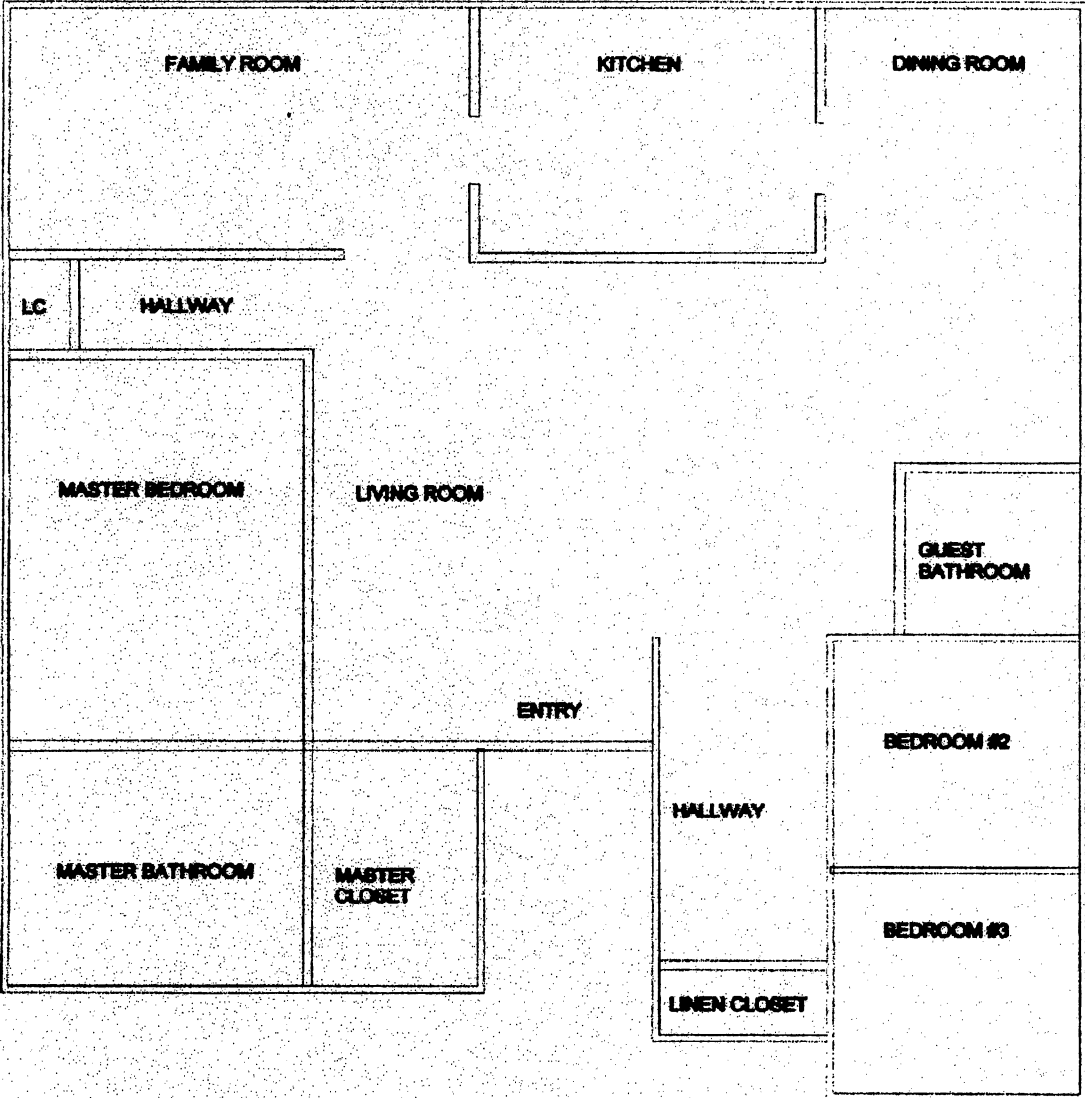

Floor Plan #2

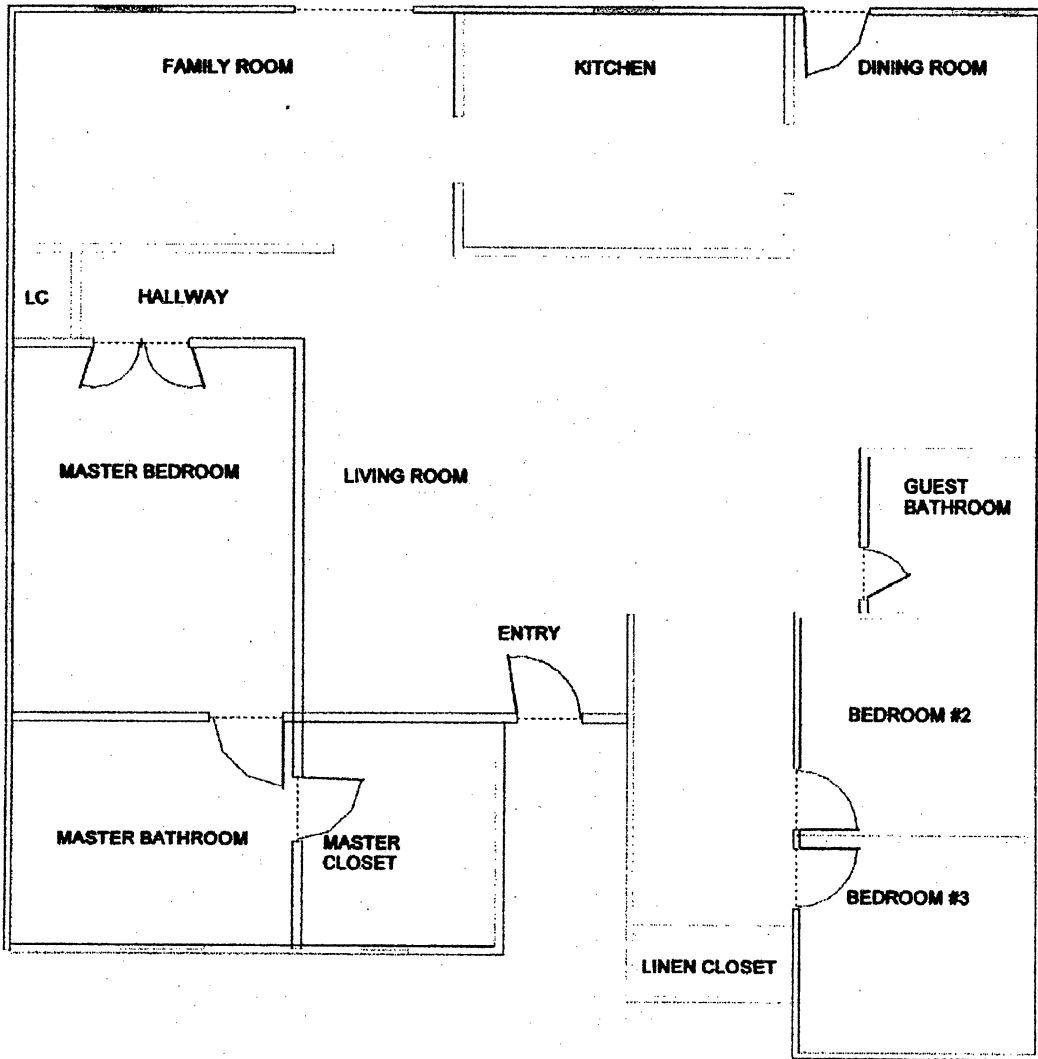

# Floor Plan #3

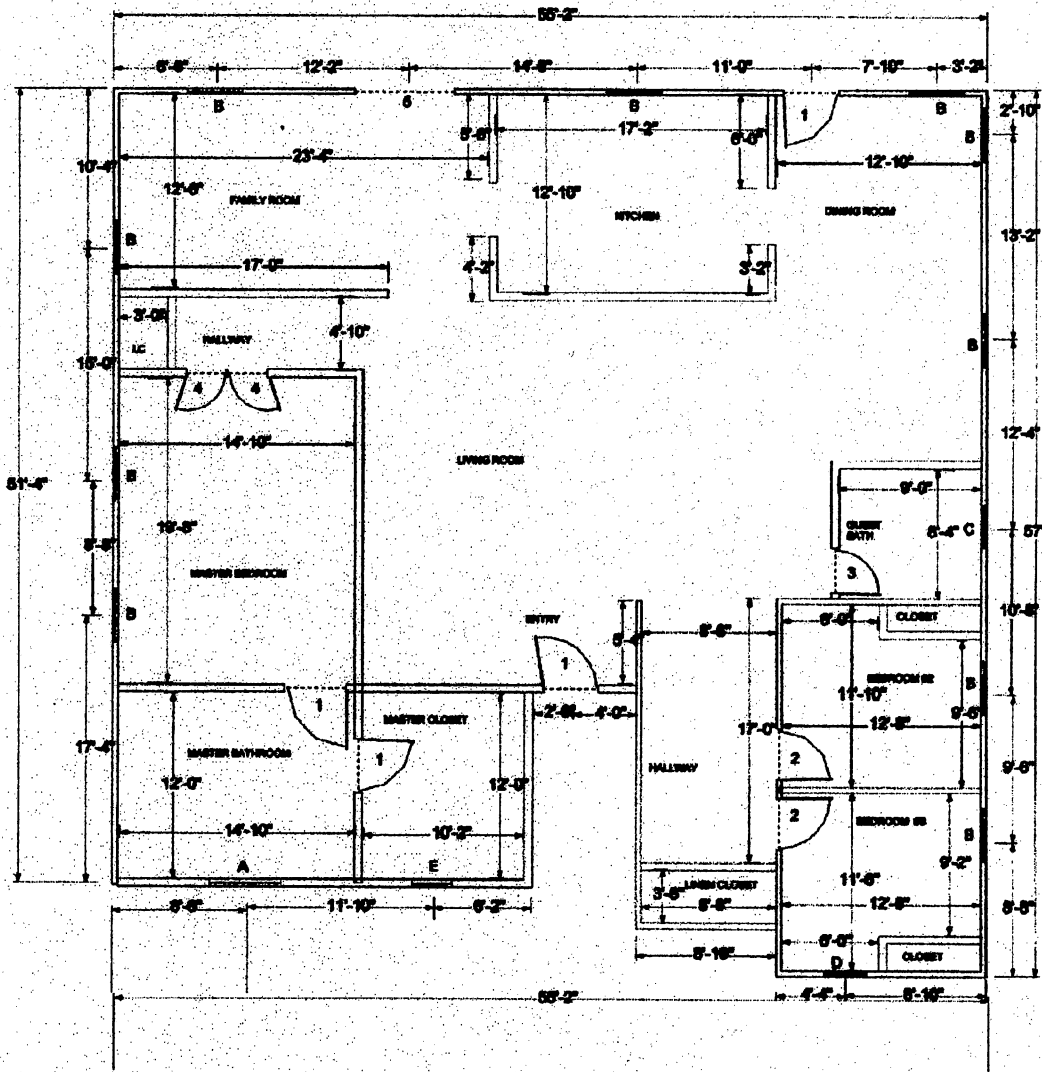

Floor Plan #4

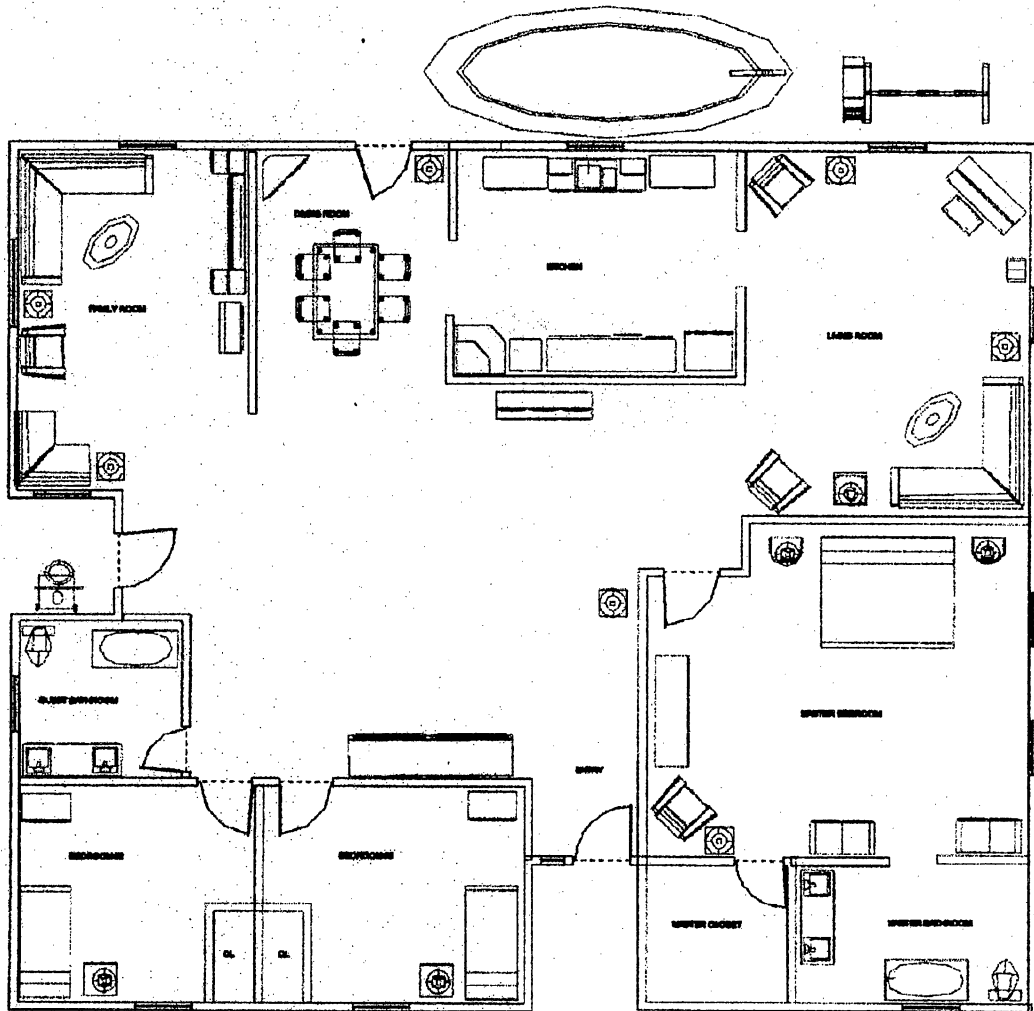

### Loan Amortization/Cost Estimation Sheet

Loan Amount \$150,000.00

Interest Rate 8%

Number of Years 30

Payments/Year 12

Payment \$1110.34

Total Interest Paid \$249,723.44

Size of House 2700 sq. ft.

Cost/sq. ft. \$45.00

Cost of Lot \$50,000.00

Estimated Cost to Build \$171,500.00

## REFERENCES

- Barker, N. (personal communication, December 16, 1999).
- Berryman, S., & et. al. (November, 1992). Integrating Academic and Vocational Education: An Equitable Way to Prepare Middle Level Students for the Future. Retrieved March 20, 2000 from the World Wide Web: [http://www.ed.gov/databases/ERIC\\_Digest/ed354283.html](http://www.ed.gov/databases/ERIC_Digest/ed354283.html).
- Bodilly, S., & Stanz, C. (May, 1992). Policy Implications of Integrating Academic and Vocational Education: An Interim Report. Working draft. Berkely: University of California, Berkely, National Center for Research in Vocational Education.
- Christopher, M. (August, 1999). MATH IN ARCHITECTURE Using Technology to Connect Math to the Real World. Gifted Child Today. Retrieved October 23, 1999 from the World Wide Web: [http://vweb.hwwilsonweb.com/cgi-bin...GT.&SP.URL.P=I\(H9Z7\)J\(0000006125](http://vweb.hwwilsonweb.com/cgi-bin...GT.&SP.URL.P=I(H9Z7)J(0000006125).
- Hepler, D. E., & Wallach, P. I. (1965). ARCHITECTURE Drafting and Design. Webster Division: McGraw-Hill Book Company.
- Johnston, E., Ed.D. (personal communication, October 12, 1994).
- Kerka, S. (1994). Vocational Education in Middle Schools. VOCATIONAL EDUCATION JOURNAL 65, no. 7 (November-December 1990): 26-42, 77. (EJ 417 775-782).
- National Association of Universities and Land-Grant Colleges (1999). Land Grants. The Land Grant Tradition, 1995. Retrieved April 29, 2000 form the World Wide Web: <http://wvu.edu/~exten/about/land.htm#why>.
- Rupp, M. (personal communication, November 16, 1999).
- Scarcella, J. A., Ph.D. (1999). School-to-Career. Retrieved March 30, 2000 from the World Wide Web: <http://soe.csusb.edu/jscarcella/STC/aboutstc.html>.

Scarcella, J. A., Ph.D. (personal communication, October 18, 1999).

Schuler, S., & Campbell, R. (1973). The Illustrated Encyclopedia of Carpentry & Woodworking Tools, Terms & Materials. Pequot Press/Random House.

Segel, Y. (1962). Drafting Made Simple. Made Simple Books: Doubleday & Company, Inc.

Spencer, H. C., & Dygdon, J. T. (1980). Basic Technical Drawing. Glencoe Division: Macmillan/McGraw-Hill.

Teaching Pre K-8 Vol. 30 P. 80-82, 1999

Toepfer, C. F. Vocational/Career/Occupational Education at the Middle Level. MIDDLE SCHOOL JOURNAL 25, no.3 (January 1994): 59-65. (EJ 477 508).

VOTECH CAREERS IN THE 21<sup>ST</sup> CENTURY. Career World (September 1, 1998). Vo-Tech Connection: Volume 27 Issue 1, p.24, 3p. Retrieved October 23, 1999 from the World Wide Web:  
<http://www.epnet.com/bin/epwgargoyl..xtsession=nUB4ZY/st=2/qn=34/ftext>.