

# POTENTIAL OF ORGANIC RANKINE CYCLES (ORC) FOR WASTE HEAT RECOVERY ON AN ELECTRIC ARC FURNACE (EAF)

Steven Lecompte<sup>\*a</sup>, Oyeniya A. Oyewunmi<sup>b</sup>, Christos N. Markides<sup>b</sup>, Marija Lazova<sup>a</sup>, Alihan Kaya<sup>a</sup>, Bernd Ameerl<sup>a</sup>, Martijn van den Broek<sup>a</sup>, Michel De Paepe<sup>a</sup>

<sup>\*</sup>Author for correspondence

<sup>a</sup>Department of Flow, Heat and Combustion Mechanics, Ghent University, Sint-Pietersnieuwstraat 41, 9000 Gent, Belgium

<sup>b</sup>Clean Energy Processes (CEP) Laboratory, Department of Chemical Engineering, Imperial College London, London SW7 2AZ, United Kingdom  
E-mail: [steven.lecompte@ugent.be](mailto:steven.lecompte@ugent.be)

## ABSTRACT

The organic Rankine cycle (ORC) is a mature technology to convert low temperature waste heat to electricity. While several energy intensive industries could benefit from the integration of an ORC, their adoption rate is rather low. One important reason is that the prospective end-users find it difficult to recognize and realise the possible energy savings. In more recent years, the electric arc furnaces (EAF) are considered as a major candidate for waste heat recovery. Therefore, in this work, the integration of an ORC coupled to a 100 MWe EAF is investigated. The effect of working with averaged heat profiles, a steam buffer and optimized ORC architectures is investigated. The results show that it is crucial to take into account the heat profile variations for the typical batch process of an EAF. An optimized subcritical ORC (SCORC) can generate an electricity output of 752 kWe with a steam buffer working at 25 bar. However, the use of a steam buffer also impacts the heat transfer to the ORC. A reduction up to 61.5% in net power output is possible due to the additional isothermal plateau of the steam.

## INTRODUCTION

Vast amounts of thermal energy from various process industries (in the form of flue-gas exhausts, cooling streams, etc.), are currently being wasted by disposal into the environment. These streams are generally considered to be low-to medium-grade temperature and as such cannot be efficiently utilized for conversion into power or shaft work by traditional heat engines such as the steam Rankine cycle. However, the recovery and reuse of these waste-heat streams can significantly improve the energy and economic efficiencies of a lot of process plants across a broad range of industries. Thus, the deployment of suitable heat engines capable of efficiently recovering and converting the wasted heat to power has been identified as one of the major pathways towards a high efficiency, sustainable and low-carbon energy future [1-3].

Various heat engines have been proposed for the valorisation of low-temperature heat sources. Prime examples of these engines include the organic Rankine cycle [4], the Kalina cycle [5], the Goswami cycle [6] and supercritical carbon dioxide (s-CO<sub>2</sub>) cycles [7]. Other novel engine configurations include various thermoacoustic and thermofluidic heat engines [8-10].

The organic Rankine cycle (ORC) in particular is an attractive proposition due to its similarity with the well-

established steam Rankine-cycle engine and the accompanying wealth of operational and maintenance experience. Furthermore, there is the design option of employing a number of organic working fluids, ranging from refrigerants to hydrocarbons and siloxanes [11], including working fluid mixtures [12,13], to optimize the heat transfer (and heat recovery) from/to the waste heat source and heat sink. ORC engines also feature quite a number of architectures such as the transcritical cycles [4,14], trilateral cycles [15], partial evaporation cycles [4] and the basic subcritical cycles, to better suit the characteristics of the heat source/sink.

## NOMENCLATURE

### Abbreviations

PPTD	Pinch point temperature difference
ORC	Organic Rankine cycle
SCORC	Subcritical ORC
TCORC	Transcritical ORC
PEORC	Partial evaporating ORC
EAF	Electric arc furnace

ORC systems have been studied and deployed for a variety of applications and in various energy intensive industries, spanning scales from a few kW to tens of MW. More recently, ORCs have been applied for waste-heat recovery from automobile and marine prime movers such as internal combustion engines and diesel engines [16]. They have also been applied for power generation and energy efficiency on offshore oil and gas processing platforms [17], sometimes in combination with windfarms [18]. In addition, over the years, the ORC has also seen applications in the petroleum refining industries from multiple waste-heat sources [19,20], and in heat recovery from (rotary) kilns in the cement and steel industries [21,22]. In these systems, an intermediate oil or water loop is employed to recover heat from the waste-heat stream before the heat is subsequently passed on the working fluid in the organic Rankine cycle.

In the steel industry in particular, being one of the highest energy and emission intensive sectors, there are multiple avenue for waste heat recovery with ORCs from the various cooling water loops in ore smelting furnaces. The electric arc furnaces (EAF) are considered as the major candidates for waste heat recovery applications [22]. Three different layouts can be conceived: heat exchangers can be placed directly outside the furnace (2000-1600 °C), just after the post combustion (200–900 °C) or they can recover heat by replacing

the dry cooler. Inlet gases into conditioning system after the dry cooler have temperature values of 80–140 °C.

Turboden implemented the first ORC-based heat recovery plant on an electric arc furnace at Elbe-Stahlwerke Feralpi located at Riesa, Germany [23]. The furnace capacity is 133 t/h with a tap-to-tap time of 45 min. The new 3 MW electrical output ORC unit exploits a portion of the saturated steam produced and recovers heat from the exhaust gases. The heat recovery system was started up on December 2013. Since the EAF is a batch process with high variable heat flow, the inclusion of a steam accumulator was crucial. Compared to thermal oil loops, which work at higher temperatures (280-310 °C), the inclusion of a steam buffer at 26 bar (228-245 °C) implies a reduction in ORC efficiency. Using thermal oil was however ruled out due to safety reasons (i.e., flammability). The heat recovery process is divided into two main sections. In the first section, the flue gas at a temperature of 1600 °C is cooled by evaporative cooling. Cooling water at boiling point is fed from the steam drum to the cooling loop. This replaces the old cold water cooled ducts. The second section replaces the existing water quench tower (comparable to the dry cooler in the case presented in section 2). A Waste Heat Steam Generator (WHSG) with vertical tubes was installed. The WHSG includes an evaporator, superheater and economizer. The payback time depends on the use of the steam. Direct use of the steam gives a pay-back time of approximately 2 to 3 years. While using the steam for a power generating system has a pay-back time of approximately 5 to 6 years.

### THE ELECTRIC ARC FURNACE

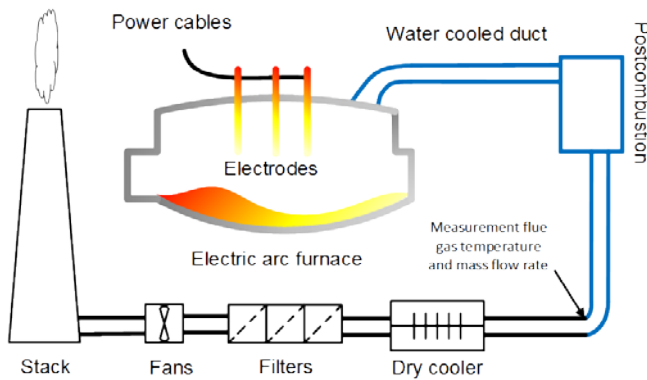

Figure 1 Lay-out of the electric arc furnace.

Data from an operational 100 MWe electric arc furnace in Belgium is taken for this case study. The layout of the plant is shown in Figure 1. There are two main heat sources available: the low temperature water cooling loops and the exhaust gas after the wet duct. The temperature in the water cooling loops is around 30 °C to 40 °C. For the flue gasses, the minimum, maximum and average temperatures and mass flow rates are reported in Table 1. A typical waste heat profile from the flue gas is shown in Figure 2. It is clear that the heat available for recuperation shows a high variation in time. For the case under consideration there are two specific constraints. First, the flue gas is available directly before the dry cooler. Secondly, the temperature of the flue gas entering the filters should be

between 80 °C and 140 °C. In the remainder of this work, only the flue gasses are considered for waste heat recovery due to the very low temperature of the water cooling loops and the high thermal capacity of the flue gas.

Table 1 Details of the flue gas heat profile.

Variable	Max.	Min.	Aver.
Temperature [°C]	578	68	283
Mass flow rate [Nm <sup>3</sup> /h]	185026	0	110772
Heat transfer rate [MW]	28	0	8.76

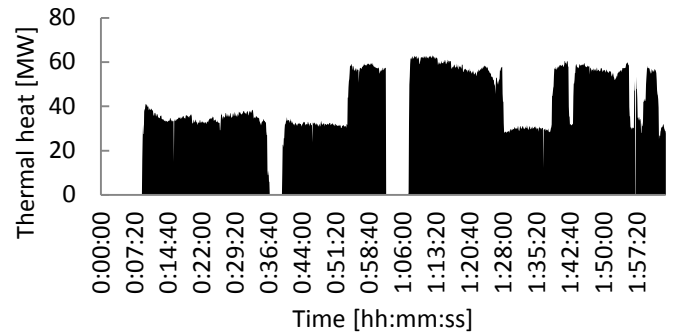

Figure 2 Available heat during the batch process (reference temperature of 90 °C)

### INTEGRATION OF THE ORGANIC RANKINE CYCLE

Organic Rankine cycles (ORC) offer the possibility to generate electricity from low capacity and low temperature heat sources. The choice for an ORC to convert heat to power is influenced by the maturity, simplicity and cost-effectiveness of the technology.

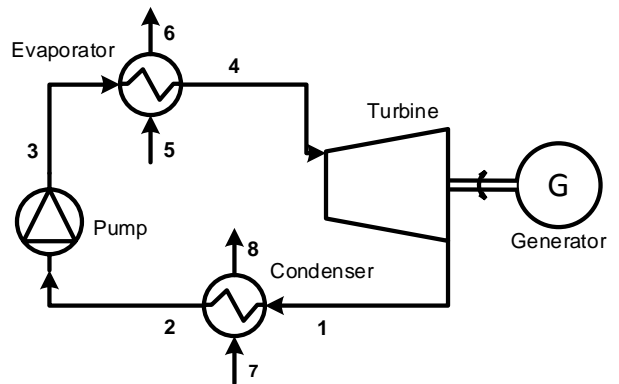

Figure 3 Component layout of the basic organic Rankine cycle.

Conceptually, the ORC is based on the classic (steam) Rankine cycle. The main difference is that instead of water, an alternative working fluid is used. Due to the organic working fluid, a low boiling point is attainable. This is beneficial for low temperature heat recovery. Also, the volume ratio of turbine outlet and inlet can be reduced compared to water. This allows using smaller and hence cheaper expanders. A reduced specific enthalpy drop permits single-stage turbines instead of the costlier multi-stage machines. Further benefits include: low

maintenance, favourable operating pressures and autonomous operation [24]. The benefits associated to ORCs have already been extensively proven by installations in the past [25].

The principle of the basic ORC is explained with help of Figure 3. The key components are the evaporator, expander, condenser and the pump. First, the hot working fluid leaves the turbine (1) and is condensed in the condenser. The heat from the condensation process is transferred to a cooling loop (7-8) which typically consists of water or air. Subsequently, the condensed working fluid enters (2) the pump and is pressurized (3). Then, the working fluid enters the evaporator and is heated to a superheated state (4). The temperature of the heat carrier (5-6) is thus gradually reduced. The superheated vapour enters the turbine in which it is expanded to provide mechanical power. Next, this cycle is again repeated. The minimum temperature difference between two streams is called the pinch point temperature difference. In the above cycle, there is both a point in both the condenser and the evaporator. The basic cycle introduced above is called the subcritical cycle (SCORC). This type of cycle is the de facto standard in commercial ORC systems. However there is ongoing research to further increase the performance of ORCs by looking at alternative cycle architectures [4].

Finally, the possibilities of integrating an ORC with a heat carrier loop are discussed. Starting with the low temperature heat from the cooling loops, the ORC working fluid could be pre-heated. However due to the high mass flow rates and low temperatures this would result in large and expensive heat exchangers. The main reason the heat from the water cooling loops cannot be used is that the condensation temperature of the ORC is not low enough to valorise this heat. Therefore, only the heat of the flue gasses is a potential heat source for the ORC.

**Table 2** Details of the flue gas heat profile.

Thermal oil loop	Pressurized hot water loop	Saturated steam loop
High temperatures (< ~400 °C)	Low temperatures (< ~200 °C)	Medium temperatures (< ~300 °C)
High reliability	Simple technical design	Complex technical design
Flammable substances		Certified personnel necessary

The next challenge is the high variance in temperature and mass flow rate of the heat source. ORC systems typically operate down to 10% of the nominal load according to Siemens and Turboden [26, 27] (Maxxtec gives a figure of 15%). This means that without thermal buffering the ORC would need to restart frequently between operations. Considering the time to start up (up to 30 minutes [28]) this provides an unworkable situation. Therefore integration of an intermediate thermal circuit, which can act as buffer, is crucial for the application under consideration. The possible heat carrier options are compared in Table 2. Thermal oil loops are normally not considered in the steel industry due to flammability concerns. Two options thus remain: the pressurized hot water loop and

the saturated steam loop. Pressurized hot water loops are found in waste incinerators [29] or the steel industry [30]. Steam loops are also found frequently in industry. An additional benefit of steam loops is the possibility to install steam accumulators to efficiently buffer heat. As such, the steam loop was selected for the further analysis.

## METHODOLOGY

### Cases under investigation

In this work five distinct cases are investigated. In the first case (Case 1), the heat profile is simplified by assuming an average value of the mass flow rate and the temperature. The cycle is optimized (to maximize the net power output) without any constraints on the evaporation pressure or the level of superheating. The resulting cycle can thus be a subcritical ORC (SCORC, i.e., a cycle with superheating), a transcritical ORC (TCORC, i.e., a cycle with evaporation pressure and temperature above the critical point) or a partial evaporation ORC (PEORC, i.e., a cycle with the turbine inlet conditions between saturated liquid and saturated vapour). In the next case (Case 2), an additional constraint is added. Instead of working with novel cycle architectures, the ORC is constraint to the commercially available subcritical type. The working parameters of the ORC are again optimized. Subsequently (Case 3) an intermediate steam loop at 26 bar (the same value as for the Elbe-Stahlwerke Feralpi plant [23]) is added which provides the opportunity to buffer heat. In this way, the ORC can operate at steady conditions and the risk of hotspots, like in a directly heated evaporator, is reduced. Also, the ORC is again optimized to work with the intermediate heat loop. In the fourth case (Case 4), the actual heat source profiles are introduced corresponding to a single batch process. Finally, in the last case (Case 5), the intermediate steam pressure and the ORC operating parameters are optimized.

### Boundary conditions and models

From a thermodynamic viewpoint, the configuration analysed with the assumptions from Table 3 is similar to that of Elbe-Stahlwerke. Approximately the same working fluid condensate temperature ( $T_2$ ) is attained. The minimum evaporator pinch point temperature difference is varied in order to keep the flue gas temperature above 90 °C. The results of the simulations are summarized in Table 4. The working fluid used is MDM. In scientific literature MDM is frequently reported as good working fluid for the application considered in this case study. Furthermore, it is known that Turboden and Maxxtec operate several of their ORCs with MDM [31]. The modelling and optimization approach has been extensively described in a previous work by the authors [32]. Thermophysical data is taken from CoolProp [33].

**Table 3** Details of the flue gas heat profile.

Variable	Value
Working fluid	MDM
$T_7$ [°C]	26
$T_8$ [°C]	46
Minimum PPTD evaporator [°C]	5 (or higher to keep $T_6 > 90$ °C)
Minimum PPTD condenser [°C]	5
Isentropic efficiency pump [-]	0.7
Isentropic efficiency turbine [-]	0.8

## RESULTS AND DISCUSSION

An overview of the results for the five cases is presented in Table 4. First (Case 1), simulations are performed on the averaged values from Table 1. The temperature at the inlet ( $T_5$ ) is 283 °C and the normalized mass flow rate is 37.7 kg/s. No intermediate steam loop is considered. The  $T$ - $s$  diagram of the ORC corresponding with maximum power output is given in Figure 4. The resulting net power output is 1132 kWe. The optimal cycle would be a partial evaporation ORC (PEORC). In this cycle, the working fluid is heated to a state between saturated liquid and saturated vapour.

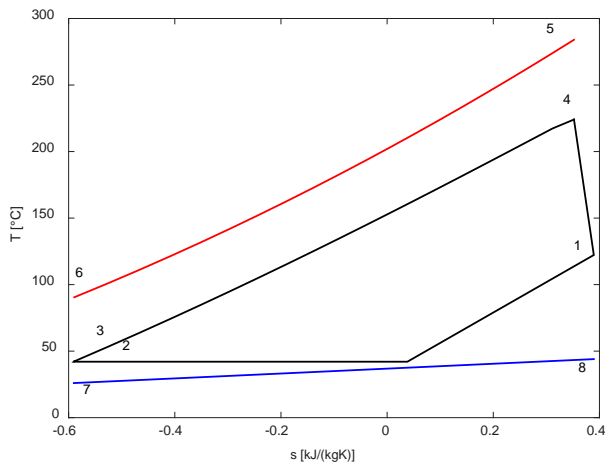
**Figure 4**  $T$ - $s$  diagram of Case 1 (PEORC)

However, PEORCs are commercially not available. Therefore the constraint is added (Case 2) that the cycle type should correspond to a subcritical ORC. The expander inlet should thus at least attain the point of saturated vapour. The  $T$ - $s$  diagram of the optimized cycle under the imposed constraint is given in Figure 5. The net power output is reduced to 989 kWe which corresponds with a decrease of 12.63%. The higher net power output from a PEORC is also confirmed in literature [32]. In these temperature ranges, the expected increase would be around 10% [32]. Care should be taken with these results as the same pump and expander efficiencies are assumed for both cycle architectures.

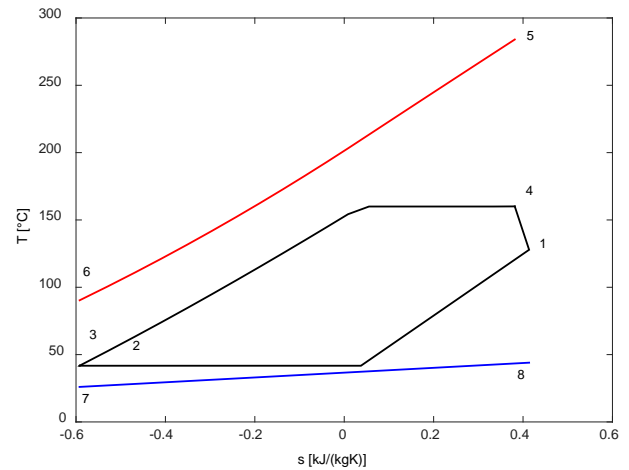
**Figure 5**  $T$ - $s$  diagram of Case 2 (SCORC)

Next (Case 3) an intermediate steam loop is introduced. Steam at 26 bar and 230 °C enters the ORC. These are the same values as for the Elbe-Stahlwerke Feralpi case. The steam is condensed and subcooled to 90 °C. The minimum pinch point temperature difference between the flue gas and the intermediate steam loops is fixed at 5 °C. The net power output in this case is further reduced to 380.5 kWe. In contrast, the thermal efficiency of the ORC only shows a minor change. The large reduction in net power output is attributed to the mismatch between the steam loop and the flue gas. As such, the flue gas exit temperature also rises above 90 °C. The results in a  $T$ - $s$  diagram are shown in Figure 6. Note that with higher inlet temperatures the pinch point can shift to the inlet of the steam loop and thus more heat can be transferred.

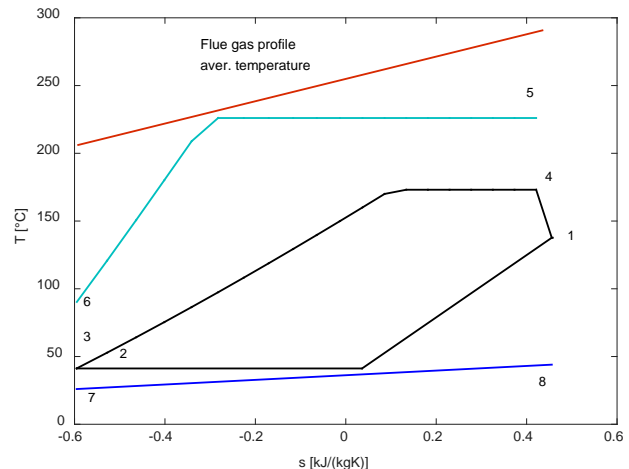
**Figure 6**  $T$ - $s$  diagram of Case 3 (subcritical ORC with steam loop)

Therefore the analysis was redone (Case 4) with time varying inputs of the real heat source profiles. It is assumed that a sufficiently large steam accumulator is present, such that the steam pressure of the intermediate loop can be assumed to be constant in time. The resulting  $T$ - $s$  diagram is shown in Figure 7. The extremes of the flue gas heat profile can easily be identified. The temperature distribution plot furthermore shows that much of the time the temperature of the waste heat is larger

than the average value. The total time averaged thermal input is now 5034 kW. The resulting time averaged net power output is 685.6 kWe.

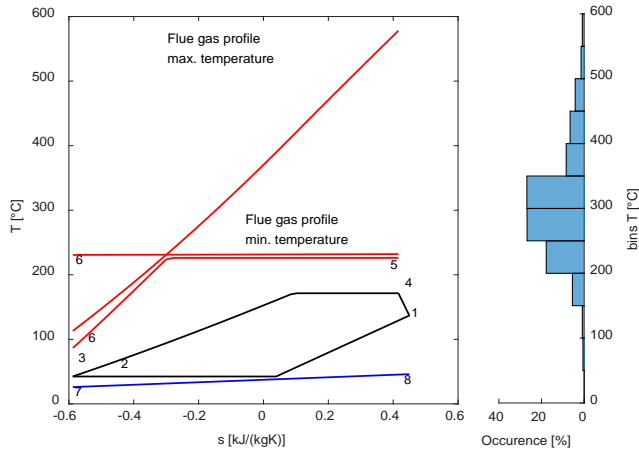

**Figure 7** T-s diagram of Case 4 (subcritical ORC with steam loop and varying heat input).

**Table 4** Simulation results of the five different cases.

Variable	Value
<i>Case 1: PEORC</i>	
Thermal power in [kW]	7470
Net power output [kWe]	1132
Thermal efficiency ORC [%]	13.35
Mass flow rate cooling water [kg/s]	84.25
<i>Case 2: SCORC</i>	
Thermal power in [kW]	7475
Net power output [kWe]	989
Thermal efficiency ORC [%]	13.35
Mass flow rate cooling water [kg/s]	86.2
<i>Case 3: SCORC + steam loop</i>	
Thermal power in [kW]	2794
Net power output [kWe]	380
Thermal power out [kW]	0
Thermal efficiency ORC [%]	13.62
Mass flow rate cooling water [kg/s]	50.1
<i>Case 4: SCORC + steam loop + variable heat</i>	
Averaged thermal power in [kW]	5034
Averaged net power output [kWe]	685.6
Averaged thermal efficiency ORC [%]	13.62
Averaged mass flow rate cooling water [kg/s]	50.1
<i>Case 5: SCORC + steam loop + variable heat + optimized</i>	
Averaged thermal power in [kW]	5429
Averaged net power output [kWe]	752
Averaged thermal efficiency ORC [%]	13.85
Averaged mass flow rate cooling water [kg/s]	53.9

In the last step (Case 5), both the pressure of the intermediate steam loop and the ORC operating parameters are optimized. The results of the optimization are presented in Table 4. The time averaged net power output is increased by 9.7% to 752.4 kWe in comparison with Case 4 where the steam pressure is not optimized. There is now a slight superheating of roughly 6 °C to attain the maximum net power output. Furthermore, the optimized steam pressure (25 bar) is close to the values of the Elbe-Stahlwerke case (26 bar). In Figure 8, the instantaneous steam flow rate generated from the waste heat stream is shown. It is obvious that there are very large variations during a single batch process. The steam flow rate varies from 0 kg/s to 10.79 kg/s. This graph can be used to size the thermal capacity of the steam buffer to allow a constant time averaged steam flow rate to the ORC of 2.11 kg/s.

**Table 5** Optimal operating parameters for Case 5.

Variable	Value
Pressure steam loop [kPa]	2,504
Evaporation pressure ORC [kPa]	194.8
Superheat ORC [°C]	5.6

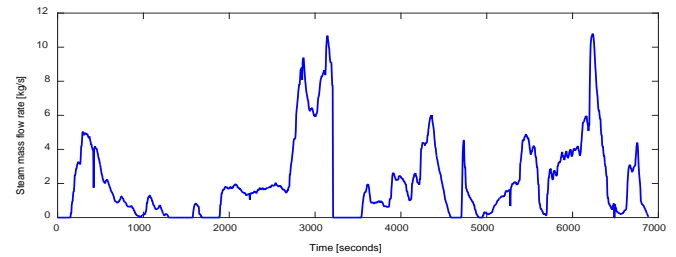

**Figure 8** Instantaneous steam flow rate to buffer vessel for a single batch process in Case 5.

## CONCLUSIONS

In this work, a comprehensive analysis on the integration of an organic Rankine cycle (ORC) coupled to an electric arc furnace (EAF) was provided. As the EAF is a batch process with large time variation in available thermal capacity and temperature, it was concluded that buffering of the heat is a necessity. The use of a steam loop is identified as a straightforward solution for the buffering need.

The subsequent analysis was subdivided in five different cases. The following main conclusions could be drawn from the results. Firstly, the partial evaporation cycle (PEORC) provides performance benefits in line with previous research in literature. The PEORC shows approximately a 10% better net electricity output compared to the SCORC. Secondly, the use of a steam buffer greatly reduces the heat transfer to the ORC due to the additional isothermal plateau of the steam. The ORC electric power output is decreased with up to 61.5%. In addition, the use of time averaged input values is not sufficient to accurately simulate ORC/EAF systems as this gives biased results. Finally, the optimal pressure of the steam buffer is 25 bar which closely resembles the 26 bar found in the Elbe-Stahlwerke Feralpi case.



## ACKNOWLEDGMENTS

The results presented in this paper were obtained within the frame of the IWT SBO- 110006 project The Next Generation organic Rankine cycles ([www.orcnext.be](http://www.orcnext.be)), funded by the Institute for the Promotion and Innovation by Science and Technology in Flanders. This financial support is gratefully acknowledged. The case study was provided ENGIE Electrabel in the framework of the 'Value of waste heat' project. This work was also supported by the UK Engineering and Physical Sciences Research Council (EPSRC) [grant number EP/P004709/1]. Data supporting this publication can be obtained on request from [steven.lecompte@ugent.be](mailto:steven.lecompte@ugent.be).

## REFERENCES

- [1] Markides CN. The role of pumped and waste heat technologies in a high-efficiency sustainable energy future for the UK. *Appl Therm Eng* 2013;53:197–209.
- [2] Ammar Y, Joyce S, Norman R, Wang Y, Roskilly AP. Low grade thermal energy sources and uses from the process industry in the UK. *Appl Energy* 2012;89(1):3–20.
- [3] Element Energy, Ecofys, Imperial College, Stevenson P (Larksdown Environmental Services), Hyde R (RHEnergy). The potential for recovering and using surplus heat from industry. Final report, department of energy and climate change. <[https://www.gov.uk/government/uploads/system/uploads/attachment\\_data/file/294900/element\\_energy\\_et\\_al\\_potential\\_for\\_recovering\\_and\\_using\\_surplus\\_heat\\_from\\_industry.pdf](https://www.gov.uk/government/uploads/system/uploads/attachment_data/file/294900/element_energy_et_al_potential_for_recovering_and_using_surplus_heat_from_industry.pdf)>; 2014.
- [4] Lecompte S, Huisseune H, van den Broek M, Vanslambrouck B, De Paepe M. Review of organic Rankine cycle (ORC) architectures for waste heat recovery. *Renew Sustain Energy Rev* 2015;47:448–61.
- [5] Ibrahim MB, Kovach RM. A Kalina cycle application for power generation. *Energy* 1993;18(9):961–9.
- [6] Goswami DY. Solar thermal power technology: Present status and ideas for the future. *Energy Sources* 1998;20(2):137–45.
- [7] Akbari AD, Mahmoudi SMS. Thermoeconomic analysis & optimization of the combined supercritical CO<sub>2</sub> (carbon dioxide) recompression Brayton/organic Rankine cycle. *Energy* 2014;78:501–12.
- [8] Backhaus S, Swift GW. A thermoacoustic-Stirling heat engine: Detailed study. *J Acoust Soc Am* 2000;107(6):3148–66.
- [9] Markides CN, Smith TCB. A dynamic model for the efficiency optimization of an oscillatory low grade heat engine. *Energy* 2011;36(12):6967–80.
- [10] Markides CN, Solanki R, Galindo A. Working fluid selection for a two-phase thermofluidic oscillator: Effect of thermodynamic properties. *Appl Energy* 2014;124:167–85.
- [11] Chen H, Goswami DY, Stefanakos EK. A review of thermodynamic cycles and working fluids for the conversion of low-grade heat. *Renew Sustain Energy Rev* 2010;14(9):3059–67.
- [12] Oyewunmi OA, Taleb AI, Haslam AJ, Markides CN. On the use of SAFT-VR Mie for assessing large-glide fluorocarbon working-fluid mixtures in organic Rankine cycles. *Appl Energy* 2016;163:263–82.
- [13] Oyewunmi OA, Markides CN. Thermo-economic and heat transfer optimization of working-fluid mixtures in a low-temperature organic Rankine cycle system. *Energies* 2016;9(6):448.
- [14] Lecompte S, Lemmens S, Huisseune H, van den Broek M, De Paepe M. Multi-objective thermo-economic optimization strategy for ORCs applied to subcritical and transcritical cycles for waste heat recovery. *Energies* 2015;8:2714–41.
- [15] Fischer J. Comparison of trilateral cycles and organic Rankine cycles. *Energy* 2011;36(10):6208–19.
- [16] Di Battista, M. Mauriello, R. Cipollone. Waste heat recovery of an ORC-based power unit in a turbocharged diesel engine propelling a light duty vehicle. *Appl Energy* 2015;152:109–120.
- [17] Tuong-Van Nguyen, Mari Voldsund, Peter Breuhaas, Brian Elmegaard. Energy efficiency measures for offshore oil and gas platforms. *Energy* 2016;117:325–340.
- [18] Valentina Orlandini, Leonardo Pierobon, Signe Schløer, Andrea De Pascale, Fredrik Haglind. Dynamic performance of a novel offshore power system integrated with a wind farm. *Energy* 2016;109:236–247.
- [19] Jian Song, Yan Li, Chun-wei Gu, Li Zhang. Thermodynamic analysis and performance optimization of an ORC (Organic Rankine Cycle) system for multi-strand waste heat sources in petroleum refining industry. *Energy* 2014;71:673–680.
- [20] Sanne Lemmens, Steven Lecompte. Case study of an organic Rankine cycle applied for excess heat recovery: Technical, economic and policy matters. *Energy Convers Manage* 2017;138:670–685.
- [21] S. Karellas, A.-D. Leontaritis, G. Panousis, E. Bellos, E. Kakaras. Energetic and exergetic analysis of waste heat recovery systems in the cement industry. *Energy* 2013;58:147–156.
- [22] F. Campana, M. Bianchi, L. Branchini, A. De Pascale, A. Peretto, M. Baresi, A. Fermi, N. Rossetti, R. Vescovo. ORC waste heat recovery in European energy intensive industries: Energy and GHG savings. *Energy Convers Manage* 2013;76:244–252.
- [23] Bause, T.; Campana, F.; Filippini, L.; Foresti, A.; Monti, N.; Pelz, T. Cogeneration with ORC at Elbe-Stahlwerke Feralpi EAF Shop. In *The Orin & Steel Technology Conference and Exposition (AISTECH 2014)*, Indianapolis, USA, 2014.
- [24] Tchanche, B.F.; Lambrinos, G.; Frangoudakis, A.; Papadakis, G. Low-grade heat conversion into power using organic Rankine cycles – A review of various applications *Renewable and Sustainable Energy Reviews* 2011, 15, 3963 - 3979.
- [25] Bronicki, L. Short review of the long history of ORC power systems. In *ORC2013*, Rotterdam, 2013.
- [26] Siemens. Fact Sheet: Organic Rankine Cycle; <[http://www.energy.siemens.com/nl/pool/hq/power-generation/steam-turbines/orc-technology/Siemens\\_FactSheet-ORC-Module.pdf](http://www.energy.siemens.com/nl/pool/hq/power-generation/steam-turbines/orc-technology/Siemens_FactSheet-ORC-Module.pdf)>, 2014.
- [27] Turboden. Organic Rankine Cycle Technology; <<http://www.turboden.eu/en/public/downloads/200-300%20kW.pdf>>, 2014.
- [28] Antti Uusitalo, Juha Honkatukia, Jari Backman, Sami Nyysönen, Experimental study on charge air heat utilization of large-scale reciprocating engines by means of Organic Rankine Cycle, *Appl Therm Eng*, 2015;89:209–219.
- [29] MIROM. Verbrandingsinstallatie: enkele cijfers. <[http://www.miom.be/verbranding\\_cijfers.html](http://www.miom.be/verbranding_cijfers.html)>, 2016.
- [30] David, G.; F. Michel; Sanchez, L. Waste heat recovery projects using Organic Rankine Cycle technology – Examples of biogas engines and steel mills applications, *World Engineers Convention*, Switzerland, Geneva, 2011.
- [31] Maraver, D.; Royo, J.; Lemort, V.; Quoilin, S. Systematic optimization of subcritical and transcritical organic Rankine cycles (ORCs) constrained by technical parameters in multiple applications. *Applied Energy* 2014, 117, 11–29.
- [32] Lecompte S, Huisseune H, van den Broek M, De Paepe M, Methodical thermodynamic analysis and regression models of organic Rankine cycle architectures for waste heat recovery. *Energy* 2016;87:60–76.
- [33] Ian H. Bell, Jorrit Wronski, Sylvain Quoilin, Vincent Lemort, Pure and pseudo-pure fluid thermophysical property evaluation and the open-source thermophysical property library coolprop. *Ind. Eng. Chem. Res* 2014;53:2498–2508.