

Technical University of Denmark



## Distributed Optimization based Dynamic Tariff for Congestion Management in Distribution Networks

Huang, Shaojun; Wu, Qiuwei; Zhao, Haoran; Li, Canbing

*Published in:*

I E E E Transactions on Smart Grid

*Link to article, DOI:*

[10.1109/TSG.2017.2735998](https://doi.org/10.1109/TSG.2017.2735998)

*Publication date:*

2017

*Document Version*

Publisher's PDF, also known as Version of record

[Link back to DTU Orbit](#)

*Citation (APA):*

Huang, S., Wu, Q., Zhao, H., & Li, C. (2017). Distributed Optimization based Dynamic Tariff for Congestion Management in Distribution Networks. I E E E Transactions on Smart Grid. DOI: 10.1109/TSG.2017.2735998

## DTU Library

Technical Information Center of Denmark

---

### General rights

Copyright and moral rights for the publications made accessible in the public portal are retained by the authors and/or other copyright owners and it is a condition of accessing publications that users recognise and abide by the legal requirements associated with these rights.

- Users may download and print one copy of any publication from the public portal for the purpose of private study or research.
- You may not further distribute the material or use it for any profit-making activity or commercial gain
- You may freely distribute the URL identifying the publication in the public portal

If you believe that this document breaches copyright please contact us providing details, and we will remove access to the work immediately and investigate your claim.

# Distributed Optimization based Dynamic Tariff for Congestion Management in Distribution Networks

Shaojun Huang, *Member, IEEE*, Qiuwei Wu, *Senior Member, IEEE*, Haoran Zhao, *Member, IEEE*, and Canbing Li, *Senior Member, IEEE*

**Abstract**—This paper proposes a distributed optimization based dynamic tariff (DDT) method for congestion management in distribution networks with high penetration of electric vehicles (EVs) and heat pumps (HPs). The DDT method employs a decomposition based optimization method to have aggregators explicitly participate in congestion management, which gives more certainty and transparency compared to the normal DT method. With the DDT method, aggregators reveal their final aggregated plan and respect the plan during operation. By establishing an equivalent overall optimization, it is proven that the DDT method is able to minimize the overall energy consumption cost and line loss cost, which is different from previous decomposition-based methods such as multiagent system methods. In addition, a reconditioning method and an integral controller are introduced to improve convergence of the distributed optimization where challenges arise due to multiple congestion points, multiple types of flexible demands and network constraints. The case studies demonstrate the efficacy of the DDT method for congestion management in distribution networks.

**Index Terms**-- Congestion management, distributed optimization, distribution system operator (DSO), dynamic tariff, electric vehicle (EV), heat pump (HP).

## I. NOMENCLATURE

### Sets

$N_B$	set of aggregators
$N_T$	set of planning periods
$N_L$	set of lines
$N_d$	set of demand bus

### Parameters

$A_{i,t}$	coefficient matrix, describe the relations between the power consumption and temperature change of the household ( $^{\circ}C$ /kW)
$B_{i,t}$	coefficient matrix of the price sensitivity (DKK/kWh/kWh)
$D$	power transfer distribution factor (PTDF)
$\tilde{E}_{i,t}, E_i$	customer to load bus mapping matrix

$F_l$	line loading limit of active power (kW)
$K_{i,t}^{a,\min}$	lower temperature limit ( $^{\circ}C$ )
$K_{i,t}^{a,\max}$	upper temperature limit ( $^{\circ}C$ )
$R$	resistance of each lines (ohm)
$\underline{V}$	voltage lower limit (p.u.)
$V_0$	voltage at node 0 (p.u.)
$Y_{LL}$	the matrix obtained by removing the first row and column of the nodal admittance matrix (S)
$Z$	the inverse matrix of $Y_{LL}$ (ohm)
$c_t$	forecast baseline energy price (DKK/kWh)
$d_{i,t}$	discharging power of EVs due to driving (kW)
$e_i^{\min}$	lower limit of the state of charge (SOC) level (kWh)
$e_i^{\max}$	upper limit of the SOC level (kWh)
$e_{i,0}$	initial SOC level (kWh)
$p_{i,t}^{\min}, p_{i,t}^{\max}$	lower/upper charging power limit of EVs (kW)
$\hat{p}_i^{\min}, \hat{p}_i^{\max}$	lower/upper power limit of HPs (kW)
$p_i^c$	active conventional power at each load point (kW)
$q_i^c$	reactive conventional power at each load point (kVar)
$u_{i,t}$	initial temperature ( $^{\circ}C$ )
$\alpha$	coefficient, step size
$\beta_1, \beta_2, \beta_3$	coefficient for reconditioning and PI control

### Vector Variables

$P_i, P_{i,t}$	charging power of EVs of one aggregator (kW)
$\hat{p}_i, \hat{p}_{i,t}$	power of HPs of one aggregator (kW)
$r_i$	regulation price, i.e., DDT rates (DKK/kWh)
$s_i$	total apparent power at each load point (kVA)
$\lambda_i$	Lagrange multiplier (LM) of line limit constraint
$\rho_i$	LM of load equation
$\omega_i$	LM of voltage constraint

### Other Symbols

$n_*$	cardinality of $N_*$ , i.e. $n_* =  N_* $
$\ \cdot\ _1$	L-1 norm of vector *
$^T$	transpose of matrix *
$\ast$	element-wise conjugate of complex vector/matrix

S. Huang, Q. Wu and H. Zhao are with the Center for Electric Power and Energy (CEE), Department of Electrical Engineering, Technical University of Denmark (DTU), 2800 Kgs. Lyngby, Denmark (e-mail: shuang@elektro.dtu.dk; qw@elektro.dtu.dk; hzhao@elektro.dtu.dk).

C. Li is with College of Electrical and Information Engineering, Hunan University, Changsha, China (e-mail: licanbing@gmail.com).

## II. INTRODUCTION

**A**LONG with the rapid development of renewable energy resources (RESs), more and more distributed generators (DG) and flexible demands such as electric vehicles (EVs) and heat pumps (HPs) will be extensively deployed in future power systems for better balance of production and consumption. Potential congestion problems might occur in distribution networks due to simultaneous charging or discharging of flexible demands. In order to postpone or avoid the reinforcement of distribution networks, distribution system operators (DSOs) can use smart coordination methods to avoid or mitigate congestion. In recent years, a number of such coordination methods has been proposed such as direct control methods [1] and indirect control methods, i.e., market-based methods, including the dynamic tariff (DT) [2]–[5], distribution locational marginal price (DLMP) [6], [7], line shadow price (not nodal prices) method [8], subsidy-based methods [9]–[12], multi-agent system methods [13], [14], and probabilistic congestion management methods [15]–[18].

Without considering probabilistic methods, which are able to enhance the underlying methods, the market based methods can be categorized into three fundamental types according to their business models: 1) DT methods [2]–[5], which are based on distribution network tariffs and function together with the existing energy market; 2) Distribution market methods, including DLMP [6], [7], which are new energy markets, and function parallel to or supplement the existing transmission-level energy market; 3) Subsidy-based methods [9]–[12], which give incentives to customers to change their planned/fixed schedules. Depending on the specific models, the multi-agent system methods may be one of the three types.

The motivation of proposing the distributed optimization based dynamic tariff (DDT) method is to provide more certainty and transparency than the normal DT method. In the DDT method, the aggregators are included in the optimization process, and they will reveal their final aggregated energy plans to the DSO and will keep the plans during the planning stage and operating stage. Thus, the DSO is more certain about the congestion management results, and the aggregators can manage the congestion cost more actively, implying more transparency of the DDT method. In the case study, a brief result of the uncertainty study of the normal DT method will be shown, while a more profound study can be seen in [18]. Another advantage of the DDT method is that the DSO does not need to know the cost functions of the aggregators. Therefore, it can protect the privacy of the aggregators, which is very important in a competitive market. As a contrast, the normal DT method needs to forecast the cost functions of the aggregators, as well as the constraints of the aggregators, which are sources of uncertainties as pointed out in [18].

The DDT method is implemented through the dual decomposition method in [19], [20]. The dual decomposition method has been successfully applied for solving many large scale constrained optimization problems, especially when there are only a few constraints involving all decision variables while other constraints and the objective function are separable with

respect to decision variables. The convergence and small optimality tolerance (how close to the optimal solution) are guaranteed if the step size is sufficiently small [21]. In the DDT method, the decision variables related to each aggregator are separable, and only the network constraints binding all decision variables. Therefore, the dual decomposition method is well suitable for the DDT method.

The most relevant work in the literature is the multi-agent system method [13], [14]. It is also based on the dual decomposition method, but the business models (cost allocation) and objectives are quite different from the DDT method. In the multiagent methods, the DSO and aggregators are agents, who optimize the energy planning separately; however, the objective is to minimize the distance to an initial schedule, which is actually an infeasible schedule when considering the network constraints. Unlike the DDT method, the multi-agent system methods are not able to ensure that the total energy consumption cost is minimized, as it is not in its objectives. In the DDT method, although the individual aggregators minimize their own costs separately, they are in line with the overall energy cost minimization as they are equivalent to the overall optimization (proved in Section IV).

There are other distributed control methods for demand coordination and/or congestion management in the literature. References [22], [23] have introduced distributed methods for coordinated EV charging; however, they are not based on the dual decomposition. A modified Benders decomposition method is employed in [24] for congestion management on transmission networks. However, this method is not suitable for the DDT method, because it requires the overall objective function. The same reason explains why the nonlinear Dantzig-Wolfe decomposition method for security constrained economic dispatch (SCED) [25] is not suitable for the DDT method either. In addition, the abovementioned methods are not able to provide a price signal that can be easily understood by the aggregators as in the dual decomposition method, where the dual variables are also known as shadow prices.

The main contributions of this paper are summarized as follows: 1) Propose the DDT concept for congestion management in distribution networks; 2) Propose algorithms to calculate DDT rates considering line loading limits, voltage limits and line loss reduction; 3) Prove that the DDT method is able to minimize the overall energy cost (and line loss cost) respecting the network constraints.

The rest of the paper is organized as follows. The DDT concept and mathematical formulation are presented in Section III. The equivalence to the centralized optimization and discussion are presented in Section IV. The method to improve the convergence is described in Section V. In Section VI, case studies are presented and discussed, followed by conclusions.

## III. DISTRIBUTED-OPTIMIZATION BASED DYNAMIC TARIFF

In this section, the market mechanism of the DDT method for congestion management of distribution networks is presented. Afterwards, the mathematical formulation of the DDT

concept is described.

#### A. Congestion Management through the DDT Concept

The essence of the DDT concept is still the same as the DT concept [4] from the economic point of view, i.e., it is a network tariff which is location and time varying, and can influence the behavior of flexible demands according to the network conditions. Same as DT, DDT does not contain energy price. Therefore, the aggregators who represent the owners of flexible demands need to buy electricity by participating in an electricity market, such as the day-ahead market in Nordic (Nord pool) or the day-ahead market of the California ISO in the USA. DDT is published before the closure of the day-ahead market. It means the aggregators are able to optimize the energy purchasing portfolio (bids submitted to the market) considering the cost due to DDT. This is how the DDT can influence the behavior of flexible demands. It is assumed in this paper that aggregators have contracts with the owners of flexible demands, and can directly or indirectly control flexible demands. It is also assumed that aggregators as business units are economically rational and pursue the maximum profits by minimizing the energy consumption cost and network utilization cost. It will be shown in the next two sections that this network utilization cost is incurred by DDT, and can include both congestion cost and network-loss cost. DDT is determined by a DSO, who is responsible for the secure operation and maintenance of distribution networks.

The difference between DDT and DT is significant, especially in the implementation part. In the DT method, the tariff is determined by the DSO through a centralized optimization, namely a DCOPT, where the DSO needs to forecast the availability as well as the energy requirements of flexible demands, and then to formulate a cost minimization objective function and relevant network constraints. If the forecast has very high accuracy, the equivalence between the DSO optimization and aggregator optimization without network constraints can be established [4]. In the aggregator optimization, the network constraint is reflected in the DT, which is why the DT method can be effective in congestion management. However, in reality, the forecast cannot be perfect. To solve this issue, [18] proposed an uncertainty management algorithm for the DT method when forecast errors exist. In the present paper, the proposed DDT method can solve this issue more reliably. In the DDT method, the tariff is not determined by the DSO solely through a centralized optimization. Instead, it is determined by iterative interactions between the DSO and aggregators. The detailed procedure of employing the DDT method for congestion management is illustrated in Fig. 1. In the beginning, the aggregators need to obtain the forecasted energy prices and the DSO needs to forecast the network status, including the conventional (inflexible) demands. The DSO initiates the iterative process by sending out tentative DDTs. Then, the aggregators will separately make their own optimal purchasing plans by minimizing the energy cost and network cost. Then, the aggregators will send back the tentative demand responses (DRs) to the DSO. With the new information, the

DSO will modify the DDTs and the iterative process will continue till the network constraints are satisfied and the final DDTs are determined.

Throughout the whole process shown in Fig. 1, the DSO doesn't know the energy cost function of the aggregators. This is a significant difference from the normal DT method, where centralized-optimization is employed and the cost function is known to the DSO. This feature also makes the DDT method slightly different from the normal optimization decomposition methods [20], [26], where the overall optimization problem is known. In the DDT method, the overall optimization problem is not known to the DSO, neither the aggregators. Each aggregator optimizes its own planning problem, which is smaller and easier to be solved because of no coupling network constraints. This is where the term 'distributed-optimization' in the DDT concept comes from.

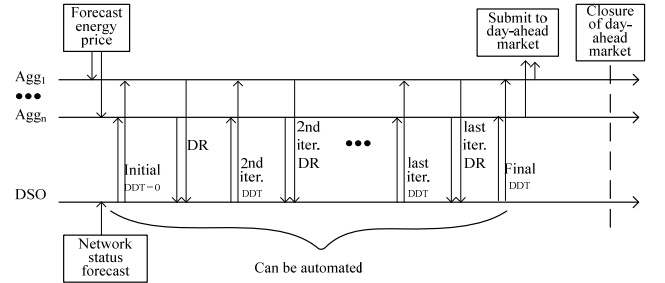

Fig. 1. Illustration of the DDT method for congestion management

Another difference between the DDT and DT methods is that the former requires aggregators keep the energy consumption level within the capacity that is revealed in the last iteration DR. This is why the DDT method can be more reliable than the DT method in congestion management. Further comparison of the two methods will be discussed in section IV.

#### B. Mathematical Formulation of DDT Method

##### 1) Formulation at the aggregator side:

In the normal DT method [4], the optimizations at the aggregator side are not part of the calculation of DTs, but only for validation of the effect of the DT method for congestion management. However, in the DDT method, the optimizations at the aggregator side are part of the determination of the DDTs. The aggregators are purely economic units who do not consider any of the network constraints. They make energy schedules based on the requirements of flexible demands and prices, including the forecast energy prices, and fixed cost (such as grid tariffs and tax), and DDTs from the DSO. In order to facilitate the study, residential EVs and HPs are chosen to be the flexible demands. EVs are assumed to have very good battery storage systems; therefore the energy losses due to leaking and charging/discharging process can be neglected. HPs are assumed to have relatively poor thermal storage systems and the heat dissipates continuously due to the natural heat transfer processes (from high temperature objects to low temperature objects of the household structure and ambience). Therefore, the combination of EVs and HPs can represent many types of flexible demands in reality, e.g., refrigerators

and air conditioners (similar to HPs), and dish washer (shiftable loads, similar to EVs).

An aggregator can use a quadratic function to represent the energy consumption cost which is shown in (1). The quadratic term in (1) is due to the price sensitivity coefficient matrix  $B_{i,t}$ . The method to determine  $B_{i,t}$  can be found in [4]. The reason of introducing the price sensitivity part in the cost function is also explained in [4]. Although one aggregator is small enough to be a price-taker in the electricity market, the incentives for an aggregator to make an optimal consumption pattern may be the same for many other aggregators. For instance, if the forecast energy price is particularly low for one hour, then every aggregator will tend to consume energy at that hour, which will make the aggregators as a group no longer the pure price-takers. Price sensitivity can capture this coaction effect of the energy planning. The network cost in (1) is represented by the term with the regulation price  $r_t$ , i.e., the DDTs. The optimal planning problem for aggregator  $i$  is formulated as (1)-(5).

$$\min_{p_{i,t}, \hat{p}_{i,t}} \sum_{t \in N_T} \left( \frac{1}{2} p_{i,t}^T B_{i,t} p_{i,t} + (c_i \mathbf{1} + E_i^T r_t)^T p_{i,t} + \frac{1}{2} \hat{p}_{i,t}^T B_{i,t} \hat{p}_{i,t} + (c_i \mathbf{1} + E_i^T r_t)^T \hat{p}_{i,t} \right) \quad (1)$$

subject to,

$$e_i^{\min} \leq \sum_{t \leq t} (p_{i,t} - d_{i,t}) + e_{i0} \leq e_i^{\max}, \forall t \in N_T, \quad (2)$$

$$p_{i,t}^{\min} \leq p_{i,t} \leq p_{i,t}^{\max} \quad \forall t \in N_T, \quad (3)$$

$$K_{i,t}^{a,\min} \leq \sum_{t \leq t} A_{i,t} \hat{p}_{i,t} + u_{i,t} \leq K_{i,t}^{a,\max}, \forall t \in N_T, \quad (4)$$

$$\hat{p}_{i,t}^{\min} \leq \hat{p}_{i,t} \leq \hat{p}_{i,t}^{\max} \quad t \in N_T. \quad (5)$$

Constraints (2) - (3) are the limits of EVs. Constraint (4) represents the thermal limits of households and (5) gives the input power limits of HPs. Constraint (4) is derived from the thermal process analysis of the household and HP as shown in [4].

After solving the optimal problem, the aggregator will have a tentative optimal plan  $(p_{i,t}^*, \hat{p}_{i,t}^*)$ . Then (6) can be used to formulate the aggregated DR, which will be sent to the DSO.

$$p_{i,t}^a = E_i(p_{i,t} + \hat{p}_{i,t}), \forall t \in N_T \quad (6)$$

## 2) Formulation at the DSO side:

At the DSO side, there is no optimization model involved, which is quite different to the normal DT method. After receiving the DR results,  $p_{i,t}^a$ , from the aggregators, the DSO will firstly determine the total apparent power load,  $s_t$ , for each bus using (9) and (10). Then, it will use a dc load flow method to determine the power flow of each feeder and the voltage level of each bus by (7) and (8), respectively. The method to estimate an approximate voltage level for each bus (the left side of (8)) is proposed by [27]. The inequality of (7) and (8) is to compare the power flow and voltage level with the network limits, respectively.

$$D \operatorname{Re}(s_t) \leq F_t, \forall t \in N_T, (\lambda_t) \quad (7)$$

$$1 - \frac{1}{V_0^2} \operatorname{Re}(Z \overline{s_t}) \geq \frac{V}{V_0}, \forall t \in N_T, (\omega_t) \quad (8)$$

$$\operatorname{Re}(s_t) = p_t^c + \sum_{i \in N_B} p_{i,t}^a, \forall t \in N_T, (\rho_t) \quad (9)$$

$$\operatorname{Im}(s_t) = q_t^c, \forall t \in N_T \quad (10)$$

The Matrix  $Z$  is the inverse matrix of the partial nodal admittance matrix  $Y_{LL}$ , which is a submatrix of the full admittance matrix ( $Y_{00}$  represents the slack bus),

$$Y = \begin{bmatrix} Y_{00} & Y_{0L} \\ Y_{L0} & Y_{LL} \end{bmatrix}.$$

Vectors  $\lambda_t$  and  $\omega_t$  in (7) and (8) can be considered as marginal prices of the network cost with respect to power flow limits and voltage limits, respectively. The marginal prices are positive if the corresponding network constraint has an effect on the DR of the aggregators, i.e., when the constraint is binding; otherwise, it will be zero. Even though the DSO does not need to model an optimization problem, it is interested in checking the network limits by establishing and evaluating the network constraints (7) and (8).

Vectors  $\lambda_t$  and  $\omega_t$  play an important role in determining proper DDT rates. They are determined iteratively. Initially, they are zero, i.e.,  $\lambda_t^{(1)} = 0$ ,  $\omega_t^{(1)} = 0$  and  $r_t^{(1)} = 0$ . Then after receiving DR results  $p_{i,t}^{a(k)}$  from the aggregators ( $k$  refers to the  $k$ -th iteration, and  $p_{i,t}^{a(k)}$  is the optimal solution based on  $k$ -th DDT, i.e.,  $r_t^{(k)}$ ,  $s_t^{(k)}$  can be determined. Then,  $\lambda_t$ ,  $\omega_t$  and  $r_t$  can be updated by,

$$\lambda_t^{(k+1)} = \lambda_t^{(k)} + \alpha (D \operatorname{Re}(s_t^{(k)}) - F_t), \forall t \in N_T, \quad (11)$$

$$\omega_t^{(k+1)} = \omega_t^{(k)} + \alpha \left( -1 + \frac{1}{V_0^2} \operatorname{Re}(Z \overline{s_t^{(k)}}) + \frac{V}{V_0} \right), \forall t \in N_T \quad (12)$$

$$r_t^{(k+1)} = D^T \lambda_t^{(k+1)} + \frac{\operatorname{Re}(Z^T)}{V_0^2} \omega_t^{(k+1)}. \quad (13)$$

In (11) and (12),  $\alpha$  represents a proper step size, and the term after  $\alpha$  is the residual of constraints (7) and (8), respectively. The justification of (11)-(13) will be discussed in Section IV. There is an implicit requirement for the marginal prices  $\lambda_t$  and  $\omega_t$ , i.e., they must be nonnegative; therefore, they are modified by,

$$\lambda_t = (\lambda_t)^+, \quad (14)$$

$$\omega_t = (\omega_t)^+, \quad (15)$$

i.e., if they are negative, they will be replaced with zero.

When the iteration converges, the residuals in (11) and (12) will be nonpositive, which means constraints (7) and (8) are satisfied. There are  $|\lambda_t^{(k+1)} - \lambda_t^{(k)}| \leq \tau$ ,  $|\omega_t^{(k+1)} - \omega_t^{(k)}| \leq \tau$  and  $|r_t^{(k+1)} - r_t^{(k)}| \leq \tau$ , where  $\lambda_t$  and  $\omega_t$  are modified values using (14) and (15), and  $\tau$  is a small tolerance. The final DDT rates are the same as the last iteration DDT rates (Fig. 1).

#### IV. EQUIVALENCE TO CENTRALIZED-OPTIMIZATION BASED DYNAMIC TARIFF AND DISCUSSION

##### A. Equivalence to Centralized-optimization Based Dynamic Tariff

In order to study the nature of the distributed optimization employed in the DDT method, an overall optimization problem is established in this section, where the distributed optimizations at the aggregator side are put together. The details of the cost function and constraints are kept unknown and represented by general symbols,  $f_i$  and  $(p_i, \hat{p}_i) \in \Omega_i$ , respectively.

The optimization models at the aggregator side can be abstracted as:  $\forall i \in N_B$ ,

$$\min_{(p_i, \hat{p}_i) \in \Omega_i} f_i(p_i, \hat{p}_i) + \sum_{i \in N_T} r_i^T \tilde{E}_{i,t}(p_i + \hat{p}_i). \quad (16)$$

For brevity, vectors  $p_{i,t}$  ( $t = t_1, t_2, \dots, t_n$ ) are stacked one on top of another to form one vector, written as  $p_i$ ; same for  $\hat{p}_i$ . The network cost  $r_i^T \tilde{E}_{i,t}(p_i + \hat{p}_i)$  in (16) is listed separately, because this part is supposed to be known to the DSO, noticing that  $p_{i,t}^a = \tilde{E}_{i,t}(p_i + \hat{p}_i)$ . Then, an overall optimization can be formed as (excluding the network cost),

$$\min_{(p_i, \hat{p}_i) \in \Omega_i} \sum_{i \in N_B} f_i(p_i, \hat{p}_i), \quad (17)$$

s.t. (7)-(10) and,

$$p_{i,t}^a = \tilde{E}_{i,t}(p_i + \hat{p}_i), \forall i \in N_B, \forall t \in N_T, (\pi_{i,t}). \quad (18)$$

It can be seen that the overall optimization problem is to minimize the total energy consumption cost with respect to the network constraints. The dual function of the overall optimization can be written as,

$$g(\lambda, \omega, \rho, \pi) = \inf_{(p_i, \hat{p}_i) \in \Omega_i} \sum_{i \in N_B} f_i(p_i, \hat{p}_i) + \sum_{i \in N_T} (D^T \lambda_i - \rho_i + \text{Re}(Z^T) \omega_i / V_0^2)^T \text{Re}(s_i) + \sum_{i \in N_B, t \in N_T} (\rho_i - \pi_{i,t})^T p_{i,t}^a + \sum_{i,t} \pi_{i,t}^T \tilde{E}_{i,t}(p_i + \hat{p}_i) \quad (19)$$

In order to be meaningful,  $g$  should not be  $-\infty$ ; therefore, there is  $D^T \lambda_i - \rho_i + \text{Re}(Z^T) \omega_i / V_0^2 = 0$  and  $\rho_i - \pi_{i,t} = 0$ . This means,

$$\pi_{i,t} = D^T \lambda_i + \text{Re}(Z^T) \omega_i / V_0^2 \quad (20)$$

The dual function can be simplified as,

$$g(\pi) = \inf_{(p_i, \hat{p}_i) \in \Omega_i} \sum_{i \in N_B} f_i(p_i, \hat{p}_i) + \sum_{i \in N_B, t \in N_T} \pi_{i,t}^T \tilde{E}_{i,t}(p_i + \hat{p}_i) \quad (21)$$

From (13) and (20), it can be seen that, at each iteration,  $r_i = \pi_{i,t}$ . This means (21) is equivalent to (16), noticing that (21) is separable with respect to  $i$ . From here, one can see that at each iteration, the distributed optimization represented by (16) is in fact an evaluation of the dual function for a given  $r_i$ . When the iteration process converges, the value of the dual problem (maximize the dual function  $g$ ) can't be improved;

therefore, an optimal solution of the dual problem is found. Due to the introduction of the price sensitivity part in the cost function of the aggregators,  $f_i$  is strictly convex; therefore, the dual gap is zero, which means the primary problem, i.e., the overall optimization, is also solved. Hence, the DDT method is able to find an optimal energy plan which minimizes the overall energy consumption cost with network constraints satisfied.

From (19), it can be seen that  $D \text{Re}(s_i^{(k)}) - F_i$  and  $-1 + \text{Re}(Z s_i^{(k)}) / V_0^2 + \underline{V} / V_0$  are subgradients of  $g$  with respect to  $\lambda_i$  and  $\omega_i$ , respectively. They are used in (11) and (12) for updating  $\lambda_i$  and  $\omega_i$ .

##### B. Comparison with the Normal DT Method

In section IV.A, it is proven that the distributed optimization is equivalent to the overall optimization (when the iteration converges), which is a centralized optimization. Therefore, if the cost functions  $f_i$  happen to be the same as those in the normal DT method, which also employs a centralized optimization, the congestion management results will be the same. But due to different business models for the DDT method and normal DT method, cost functions are not the same. In the DT method, cost functions are results of the DSO forecast, while in the DDT method, the cost functions remain unknown to the DSO.

In [5], line loss reduction is included in the DT method. Assume that the line loss cost function is  $\sum_{i \in N_T} h_i(\text{Re}(s_i))$ . The

cost function can be estimated with a linear method [28], a piece-wise linear method [29] or second order polynomials, such as  $h(\text{Re}(s_i)) \approx \frac{c_i}{V_0^2} \text{Re}(s_i^T) D^T R D \text{Re}(s_i)$ , where  $R$  is a

diagonal matrix whose main elements are the line resistance.

Rewriting the dual function (19) or using KKT conditions, there is (22), which means the DDT updating formula (13) can be modified to include the gradient of the line loss cost function and the line loss reduction is incorporated with the DDT method.

$$\rho_i = D^T \lambda_i + \text{Re}(Z^T) \omega_i / V_0^2 + \nabla h_i, \forall t \in N_T \quad (22)$$

In [5], feeder reconfiguration is included in the DT method. However, it can't be incorporated with the DDT method. The optimal feeder reconfiguration needs to be determined through an optimization problem; however, the primal problem (cost function) in the DDT method is not known and can't be solved.

##### C. Comparison with the dual decomposition Method

One can see that the DDT method has adopted the idea from the dual decomposition method [20], [26]. However, they are not exactly the same. In the dual decomposition problem, the primary problem (the overall optimization) is known, but in the DDT method, it is not. For this reason, many algorithms of the dual decomposition method involving the manipulation of the cost function can't be employed here.

## V. RECONDITIONING AND ADDING INTEGRAL CONTROLLER FOR CONVERGENCE IMPROVEMENT

Although the convergence of the dual decomposition method is assured provided that the step size is sufficiently small [21], the speed of the convergence is quite slow in some cases. From (11)-(13), it can be seen that both  $\lambda_i$  and  $\omega_i$  have contributions to the DDT rates. However, they have different weights:  $D^T$  and  $\text{Re}(Z^T)/V_0^2$  respectively. Because  $D^T \gg \text{Re}(Z^T)/V_0^2$ ,  $\omega_i$  has much less importance in the DDT rates calculation. This is not true. In reality, the voltage constraints should have same importance as the line flow constraints in congestion management. According to [30], a scaling matrix  $K$  can be used to adjust the weights of  $\lambda_i$  and  $\omega_i$ , and the negative gradient flow can be abstracted as (the step size is included) in Fig. 2, where  $x = \begin{bmatrix} \lambda \\ \omega \end{bmatrix}$ .

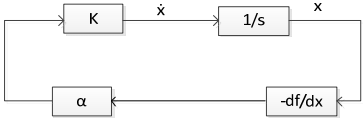

Fig. 2. Negative gradient flow with step size  $\alpha$  (P controller)

In this paper, a scaling factor is used instead of the scaling matrix to have simplicity. Accordingly, (13) can be modified as (23) with an additional scaling factor  $\beta_1$ . Without  $\beta_1$ , when  $\lambda_i$  converges,  $\omega_i$  may be far away from convergence, which slows down the overall convergence speed.

$$r_i^{(k+1)} = D^T \lambda_i^{(k+1)} + \beta_1 \frac{\text{Re}(Z^T)}{V_0^2} \omega_i^{(k+1)}. \quad (23)$$

In addition, a diminishing integral controller (I controller) is added in parallel to the step size factor (P controller) for updating  $\lambda_i$  and  $\omega_i$  in order to speed up the convergence. Accordingly, (11) and (12) can be modified as,

$$\lambda_i^{(k+1)} = \lambda_i^{(k)} + \alpha (D \text{Re}(s_i^{(k)}) - F_i) + \frac{\beta_2}{k} \sum_{j=1}^k (D \text{Re}(s_i^{(j)}) - F_i), \forall t \in N_T, \quad (24)$$

$$\omega_i^{(k+1)} = \omega_i^{(k)} + \alpha (-1 + \text{Re}(Z s_i^{(k)}) / V_0^2 + \underline{V} / V_0) + \frac{\beta_3}{k} \sum_{j=1}^k (-1 + \text{Re}(Z s_i^{(j)}) / V_0^2 + \underline{V} / V_0), \forall t \in N_T, \quad (25)$$

where  $\alpha$  is the step size (P controller), and  $\beta_2/k$  and  $\beta_3/k$  are the gains of the I controller, which are diminishing as  $k$  grows. The negative gradient flow can be updated as in Fig. 3.

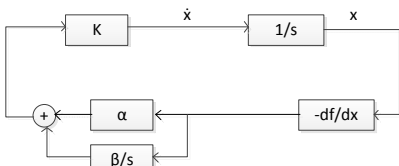

Fig. 3. Negative gradient flow with PI controller

## VI. CASE STUDIES

### A. Case study parameters

The single line diagram of the four-feeder distribution network of the Roy Billinton Test System (RBTS) [31] is shown in Fig. 4. Line segments of the feeder one are labeled in Fig. 4, among which L2, L4, L6, L8, L9, L11, and L12 refer to the transformers connecting the corresponding load points (LP1 to LP7). The study is focused on this feeder because it has the most diversity among all the feeders: 5 residential load points with different peak conventional demands and two commercial load points. The detailed data of these load points are listed in Table I. The peak conventional demands of residential customers are assumed to occur at 18:00 when people arrive home and start cooking. Assume that the EVs and HPs have unit power factor. The DSO has improved the power factor of the conventional consumption by reactive power compensations, and the remaining reactive power consumption is 10% of the conventional active power consumption. The line parameters are shown in Table II.

The key parameters of the simulation are listed in Table III. The lower voltage limit is set to be 0.948 p.u., in order to have a small margin (0.006~0.008 p.u.) compared to the assumed physical limit 0.94 p.u. The EV availability shown in Fig. 5 is from the driving pattern study in [32]. The household area is a random number between 100 and 200 ( $m^2$ ).

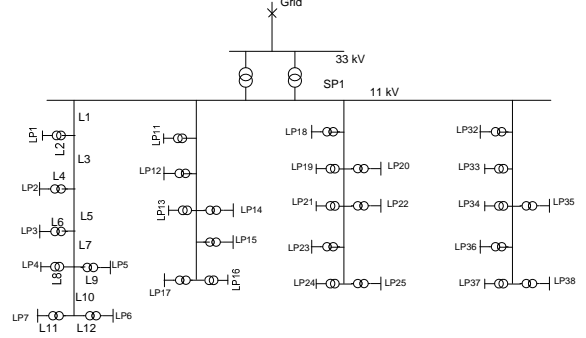

Fig. 4. Single line diagram of the distribution network

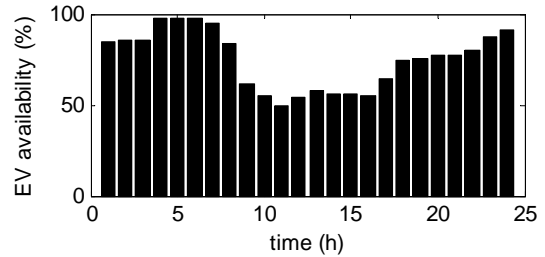

Fig. 5. EV availability

TABLE I  
LOAD POINT DATA

load points	customer type	peak conv. act. power per point (kW)	peak conv. react. power per point (kVar)	number of customers per point
LP1-LP4	residential	886.9	88.69	200
LP5	residential	813.7	81.37	200
LP6,LP7	commercial	671.4	67.14	10

TABLE II  
LINE PARAMETERS

Line	r (ohm)	x (ohm)	x/r ratio
1	0.1210	0.0370	0.3058
2	0.3000	3.0000	10.0000
3	0.4233	0.0943	0.2228
4	0.3000	3.0000	10.0000
5	0.3722	0.0829	0.2227
6	0.3000	3.0000	10.0000
7	0.4403	0.0981	0.2228
8	0.3000	3.0000	10.0000
9	0.3000	3.0000	10.0000
10	0.3091	0.0689	0.2229
11	0.3000	3.0000	10.0000
12	0.3000	3.0000	10.0000

TABLE III  
KEY PARAMETERS OF THE SIMULATION MODEL ([32], [33])

parameter	value
EV battery size	25 kWh
Peak charging power	11 kW (3 phase)
Energy consumption per km	150 Wh/km
Minimum SOC	20%
Maximum SOC	85%
Average driving distance	40 km
Coefficient of performance (COP) of HP	2.3
Min Temp. of the House	20 °C
Max Temp. of the House	24 °C
Voltage rating = $V_0$	11 kV
Lower voltage limit	0.948 p.u.
Transformer rating	1~3 MVA
L2 limit (kW)	1100
L3 limit (kW)	7000
L4 limit (kW)	2700
Price sensitivity (DKK/kWh/ kWh)	0.01
$\beta_1, \beta_2, \beta_3$	10, 10, 12

### B. Case study results

The simulation was carried out using the GAMS optimization software [34] for the distributed optimization part at the aggregator side, and a Matlab script for the iteration control, i.e., the DDT calculation and convergence check at the DSO side.

#### 1) Congestion Management Results:

Firstly, the distributed optimization was performed with initial zero DDT. The line loading results are shown in Fig. 6, where there is congestion at hour 17, 18, 19 and 24. Then the iteration starts. When the iteration converges, the final DDT can be determined. The line loadings of L2, L3 and L4 after using the DDT method are shown in Fig. 7, and they are all lower than the limits. As the voltage constraints are also included in the DDT calculation, the voltage profile of the critical bus, LP4, is above the lower voltage limit, which is shown in Fig. 8. It can be seen that the error between the approximated voltage and accurate one (by the load flow method) is less than 0.5%.

The base energy prices and final energy prices with the DDT for the customers at LP1-5 are shown in Fig. 9. Because there is congestion at hour 17-19 due to conventional peaks and the HP consumption, the DDT rates have to be very high at hour 19, 18 and 17 (rates: 19>18>17) such that the energy

price at hour 16 will become attractive enough to the HP consumption. Also, because the voltage at LP4 (critical bus) is more sensitive to loads at the bottom of the feeder than the top, DDT rates have relations: LP4>LP5>LP3>LP2. DDT rates at LP1 are results from both line loading limit of L2 and voltage limits of LP4; therefore, they are relatively high.

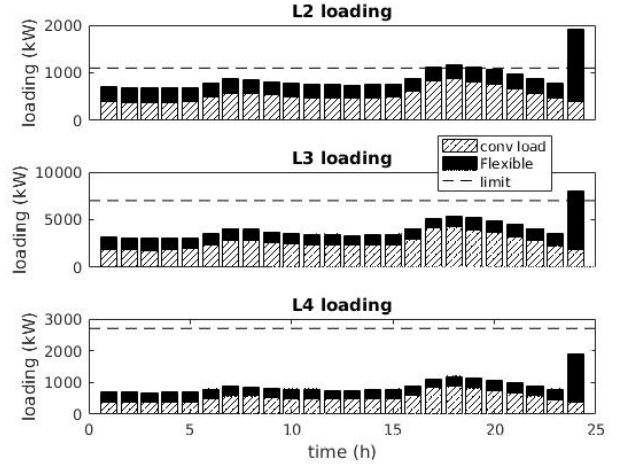

Fig. 6. Line loading results with the DDT=0

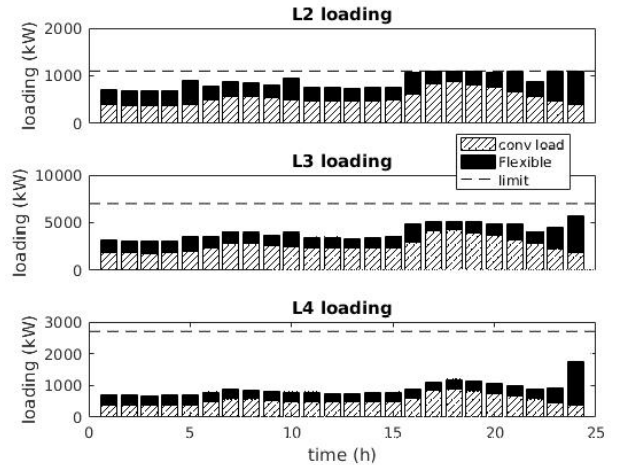

Fig. 7. Line loading results after using the DDT method

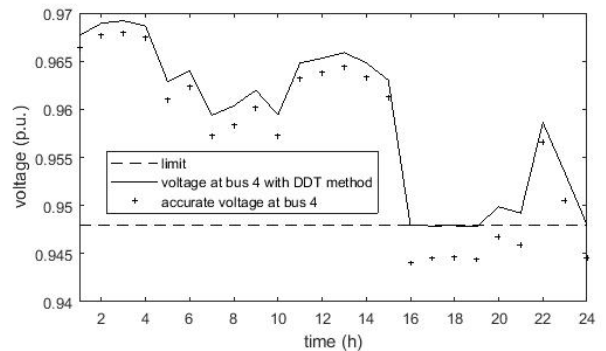

Fig. 8. Voltage profile of LP4



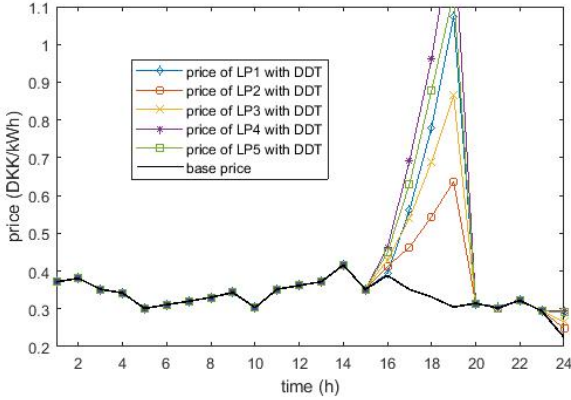

Fig. 9. Forecast system prices (base price) and final prices (including DDT)

## 2) Convergence Observation:

The key variables, including the line flow and voltage, the corresponding marginal prices  $\lambda_i$  and  $\omega_i$ , and the DDT rates are observed in the iteration process. The results are shown in Fig. 10. It can be seen that the congestion at hour 24 is solved very quickly, as the cyan curves (hour 24) are settled very quickly (less than 20 iterations).

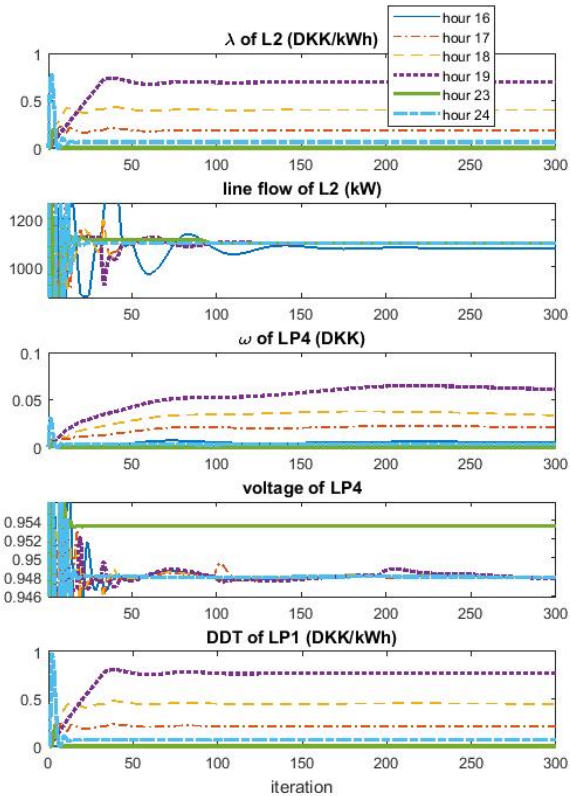

Fig. 10 Iteration observation of the key variables

However, the congestion at hour 17-19 is solved relatively slow. It takes about 200 iterations for the blue, magenta, yellow and purple (hour 16-19) curves, especially in the second, third and fourth sub graphs, to settle down. Two reasons are accountable for this. One is that the congestion at these hours

is actually caused by HPs, and HPs have poor heat storage efficiency compared to the battery storage of EVs. The other one is that the conventional peaks occur at those hours, and the congestion occurs at three consecutive hours and all the HP loads should be shifted to hour 16 in order to solve congestion at hour 17-19. This is particularly challenging for a distributed optimization method. Without reconditioning of the constraints, e.g., let  $\beta_1 = 0$ , there is no sign of convergence of variables  $\omega_i$  and voltage after 300 iterations. In practice, the iteration process including the communication between the DSO and the aggregators should be automated, and the communication time for each iteration should be kept within 1 or 2 seconds.

## 3) Comparison with DT Method:

When using the DT method instead of the DDT for congestion management, uncertainty will occur if a forecast error exists. For instance, assume that the DSO forecast 6 kWh for the average EV demand; however, the real EV demands (the aggregators collected from their customers) are different under different scenarios shown in Table IV. The congestion management by the DT method may fail as shown in Table IV. However, the DDT method can always succeed, implying that the DDT method has more certainty about the congestion management results.

TABLE IV  
COMPARISON OF DT AND DDT

Scenario	Relative Error: (Real Demand - Forecast)	Results by DT	Results by DDT
1	30%	Fail (over loading 9.9%)	Success
2	20%	Fail (over loading 6.8%)	Success
3	10%	Fail (over loading 3.4%)	Success
4	-10%	Success	Success

## VII. CONCLUSIONS

This paper proposes the DDT method for congestion management in distribution networks with high penetration of EVs and HPs. The DDT method employs a decomposition-based optimization method to have the aggregators participate in the congestion management explicitly, which gives more certainty and transparency compared to the normal DT method. Simulation results show that employing the DT method instead of the DDT method for congestion management may lead to failure if there is a forecast error, and the overloading level depends on how big the error is. The reconditioning method and the PI controller can be used to improve the convergence especially when the optimization structure is complicated due to multiple congestion points and multiple types of flexible demands and network constraints. The case studies have demonstrated and validated the efficacy of the DDT method for congestion management. In the future work, the ACOPTF, which is more accurate than the DCOPTF, will be employed to determine the DDT.

## REFERENCES

- [1] S. Huang, Q. Wu, Z. Liu, and A. H. Nielsen, "Review of congestion management methods for distribution networks with high penetration of distributed energy resources," in *Proc. 2014 IEEE PES Innovative Smart Grid Technologies, Europe*, pp. 1–6.
- [2] N. O'Connell, Q. Wu, J. Østergaard, A. H. Nielsen, S. T. Cha, and Y. Ding, "Day-ahead tariffs for the alleviation of distribution grid congestion from electric vehicles," *Electr. Power Syst. Res.*, vol.92, pp. 106–114, 2012.
- [3] R. Li, Q. Wu, and S. S. Oren, "Distribution locational marginal pricing for optimal electric vehicle charging management," *IEEE Trans. Power Syst.*, vol.29, no.1, pp. 203–211, Jan. 2014.
- [4] S. Huang, Q. Wu, S. S. Oren, R. Li, and Z. Liu, "Distribution locational marginal pricing through quadratic programming for congestion management in distribution networks," *IEEE Trans. Power Syst.*, vol.30, no.4, pp. 2170–2178, Jul. 2015.
- [5] S. Huang, Q. Wu, L. Cheng, and Z. Liu, "Optimal reconfiguration-based dynamic tariff for congestion management and line loss reduction in distribution networks," *IEEE Trans. Smart Grid*, vol.7, no.3, pp. 1295–1303, May 2016.
- [6] P. M. Sotkiewicz and J. M. Vignolo, "Nodal pricing for distribution networks: Efficient pricing for efficiency enhancing DG," *IEEE Trans. Power Syst.*, vol.21, no.2, pp. 1013–1014, May 2006.
- [7] G. T. Heydt, B. H. Chowdhury, M. L. Crow, D. Haughton, B. D. Kiefer, F. Meng, and B. R. Sathyanarayana, "Pricing and control in the next generation power distribution system," *IEEE Trans. Smart Grid*, vol.3, no.2, pp. 907–914, Jun. 2012.
- [8] B. Biegel, P. Andersen, J. Stoustrup, and J. Bendtsen, "Congestion management in a smart grid via shadow prices," in *Proc. 2012 8th IFAC Symposium on Power Plant and Power System Control*, pp. 518–523.
- [9] M. R. Sarker, M. A. Ortega-Vazquez, and D. S. Kirschen, "Optimal coordination and scheduling of demand response via monetary incentives," *IEEE Trans. Smart Grid*, vol.6, no.3, pp. 1341–1352, May 2015.
- [10] H. Zhong, L. Xie, and Q. Xia, "Coupon incentive-based demand response: theory and case study," *IEEE Trans. Power Syst.*, vol.28, no.2, pp. 1266–1276, May 2013.
- [11] C. Zhang, Y. Ding, N. Nordentoft, P. Pinson, and J. Østergaard, "FLECH-A danish market solution for DSO congestion management through DER flexibility services," *J. Mod. Power Syst. Clean Energy*, vol.2, no.2, pp. 126–133, 2014.
- [12] S. Huang and Q. Wu, "Dynamic subsidy method for congestion management in distribution networks," *IEEE Trans. Smart Grid*, pp. 1–1, 2016.
- [13] B. Moradzadeh and K. Tomovic, "Two-stage residential energy management considering network operational constraints," *IEEE Trans. Smart Grid*, vol.4, no.4, pp. 2339–2346, Dec. 2013.
- [14] S. Weckx, R. D'Hulst, B. Claessens, and J. Driesensam, "Multiagent charging of electric vehicles respecting distribution transformer loading and voltage limits," *IEEE Trans. Smart Grid*, vol.5, no.6, pp. 2857–2867, Nov. 2014.
- [15] M. Esmaili, N. Amjadi, and H. A. Shayanfar, "Stochastic congestion management in power markets using efficient scenario approaches," *Energy Convers. Manag.*, vol.51, no.11, pp. 2285–2293, 2010.
- [16] M. Hojjat and M. H. Javidi D. B., "Probabilistic congestion management considering power system uncertainties using chance-constrained programming," *Electr. Power Components Syst.*, vol.41, no.10, pp. 972–989, Jul. 2013.
- [17] Z. Liu, Q. Wu, S. Oren, S. Huang, R. Li, and L. Cheng, "Distribution locational marginal pricing for optimal electric vehicle charging through chance constrained mixed-integer programming," *IEEE Trans. Smart Grid*, pp. 1–1, 2016.
- [18] S. Huang, Q. Wu, L. Cheng, Z. Liu, and H. Zhao, "Uncertainty management of dynamic tariff method for congestion management in distribution networks," *IEEE Trans. Power Syst.*, vol.31, no.6, pp. 4340–4347, Nov. 2016.
- [19] D. P. Bertsekas, *Nonlinear Programming*. Massachusetts: Athena Scientific, 2016.
- [20] S. Boyd, L. Xiao, A. Mutapcic, and J. Mattingley, "Notes on decomposition methods," 2008. Available: <https://pdfs.semanticscholar.org/d746/f6b5f69401b147996d21a4b5940f6dd40020.pdf>. [Accessed: 26-Mar-2017].
- [21] S. Boyd, L. Xiao, and A. Mutapcic, "Subgradient methods," 2003. Available: [https://web.stanford.edu/class/ee392o/subgrad\\_method.pdf](https://web.stanford.edu/class/ee392o/subgrad_method.pdf). [Accessed: 26-Mar-2017].
- [22] L. Gan, U. Topcu, and S. H. Low, "Optimal decentralized protocol for electric vehicle charging," *IEEE Trans. Power Syst.*, vol.28, no.2, pp. 940–951, May 2013.
- [23] Z. Fan, "A distributed demand response algorithm and its application to PHEV charging in smart grids," *IEEE Trans. Smart Grid*, vol.3, no.3, pp. 1280–1290, Sep. 2012.
- [24] M. Esmaili, F. Ebadi, H. A. Shayanfar, and S. Jadid, "Congestion management in hybrid power markets using modified Benders decomposition," *Appl. Energy*, vol.102, pp. 1004–1012, Feb. 2013.
- [25] M. Aganagic and S. Mokhtari, "Security constrained economic dispatch using nonlinear Dantzig-Wolfe decomposition," *IEEE Trans. Power Syst.*, vol.12, no.1, pp. 105–112, 1997.
- [26] S. Boyd, N. Parikh, E. Chu, B. Peleato, and J. Eckstein, "Distributed optimization and statistical learning via the alternating direction method of multipliers," *Mach. Learn.*, vol.3, no.1, pp. 1–122, 2010.
- [27] S. Bolognani and S. Zampieri, "On the existence and linear approximation of the power flow solution in power distribution networks," *IEEE Trans. Power Syst.*, vol.31, no.1, pp. 163–172, Jan. 2016.
- [28] A. Abur, "A modified linear programming method for distribution system reconfiguration," *Int. J. Electr. Power Energy Syst.*, vol.18, no.7, pp. 469–474, Oct. 1996.
- [29] T. N. dos Santos and A. L. Diniz, "A dynamic piecewise linear model for DC transmission losses in optimal scheduling problems," *IEEE Trans. Power Syst.*, vol.26, no.2, pp. 508–519, May 2011.
- [30] F. Dörfler, "Distributed consensus-based optimization." Available: [http://control.ee.ethz.ch/~florian/docs/Teaching/ATIC\\_2017/Optimization\\_Lecture.pdf](http://control.ee.ethz.ch/~florian/docs/Teaching/ATIC_2017/Optimization_Lecture.pdf). [Accessed: 27-Jun-2017].
- [31] R. N. Allan, R. Billinton, I. Sjarief, L. Goel, and K. S. So, "A reliability test system for educational purposes—basic distribution system data and results," *IEEE Trans. Power Syst.*, vol.6, no.2, pp. 813–820, May 1991.
- [32] Q. Wu, A. H. Nielsen, J. Østergaard, F. Marra, and C. Træholt, "Driving pattern analysis for electric vehicle (EV) grid integration study," in *Proc. 2010 IEEE PES Innovative Smart Grid Technologies Conference Europe (ISGT Europe)*, pp. 1–6.
- [33] J. M. Nyers and A. J. Nyers, "COP of heating-cooling system with heat pump," in *Proc. IEEE 3rd International Symposium on Exploitation of Renewable Energy Sources (EXPRES)*, pp. 17–21.
- [34] R. E. Rosenthal. (2014, Aug. ). GAMS — A user's guide. GAMS Development Corporation, Washington, DC, USA. [online]. Available: <http://www.gams.com/dd/docs/bigdocs/GAMSUsersGuide.pdf>.

## VIII. BIOGRAPHIES



Shaojun Huang (S'13) obtained the B. Eng. from Department of Electrical Engineering, Tsinghua University, Beijing, P. R. China, in 2001. He obtained the MSc from Department of Energy Technology, Aalborg University, Denmark, in 2013.

Currently, he is pursuing his PhD degree in Centre for Electric Power and Energy, Department of Electrical Engineering, Technical University of Denmark.

His research interests are congestion management for distribution networks with high penetration of distributed energy resources.

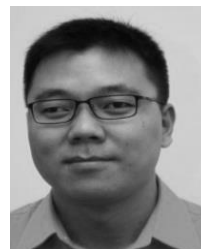

Qiuwei Wu (M'08-SM'15) obtained the B. Eng. and M. Eng. from Nanjing University of Science and Technology, Nanjing, P. R. China, in 2000 and 2003, respectively, both in Power System and Its Automation. He obtained the PhD degree from Nanyang Technological University, Singapore, in 2009, in Power System Engineering.

He was a senior R&D engineer with Vestas Technology R&D Singapore Pte Ltd from Mar. 2008 to Oct. 2009. He has been working at Department of Electrical Engineering, Technical University of Denmark (DTU) since Nov. 2009 (PostDoc Nov. 2009–Oct. 2010, Assistant

Professor Nov. 2010-Aug. 2013, Associate Professor since Sept. 2013). He was a visiting scholar at Department of Industrial Engineering & Operations Research (IEOR), University of California, Berkeley from Feb. 2012 to May 2012 funded by Ministry of Science, Technology and Innovation, Denmark. He is also a visiting professor named by Y. Xue, an Academician of Chinese Academy of Engineering, at Shandong University, China.

His research interests are modeling and control of wind power, electric vehicle, active distribution networks, electricity market and energy system integration. He is an Editor of IEEE Transactions on Smart Grid and IEEE Power Engineering Letters. He is also an Associate Editor of International Journal of Electrical Power and Energy Systems.



**Haoran Zhao** (S'12-M'15) received the B.E. degree in electrical engineering and automation from Shandong University, Jinan, China, in 2005, the M.E. degree in electrical engineering and automation from the Technical University of Berlin, Berlin, Germany, in 2009, and the Ph.D. degree in electrical engineering from the Technical University of Denmark, Kgs. Lyngby, Denmark, in 2015.

He is a Postdoc with the Center for Electric Technology, Technical University of Denmark. He worked as Electrical Engineer with State Grid Corporation of China (SGCC), Beijing, China, in 2005. From August 2010 to September 2011, he worked as Application Developer with DIGSILENT GmbH, Gomaringen, Germany. His research interests include modeling and integration study of wind power, control of energy storage system, and voltage stability analysis.



**Canbing Li** (M'06-SM'13) was born in Hunan Province, China, in 1979. He received the B.E. and Ph.D. degrees from Tsinghua University, Beijing, China, in 2001 and 2006, respectively, both in electrical engineering.

He is currently a Professor with Hunan University, Changsha, China.