



Environmental performance of household waste management in Europe - an example of 7 countries

Andreasi Bassi, Susanna; Christensen, Thomas Højlund; Damgaard, Anders

Published in:
Waste Management

Link to article, DOI:
[10.1016/j.wasman.2017.07.042](https://doi.org/10.1016/j.wasman.2017.07.042)

Publication date:
2017

Document Version
Publisher's PDF, also known as Version of record

[Link back to DTU Orbit](#)

Citation (APA):
Andreasi Bassi, S., Christensen, T. H., & Damgaard, A. (2017). Environmental performance of household waste management in Europe - an example of 7 countries. *Waste Management*, 69, 545-557. DOI: 10.1016/j.wasman.2017.07.042

DTU Library

Technical Information Center of Denmark

General rights

Copyright and moral rights for the publications made accessible in the public portal are retained by the authors and/or other copyright owners and it is a condition of accessing publications that users recognise and abide by the legal requirements associated with these rights.

- Users may download and print one copy of any publication from the public portal for the purpose of private study or research.
- You may not further distribute the material or use it for any profit-making activity or commercial gain
- You may freely distribute the URL identifying the publication in the public portal

If you believe that this document breaches copyright please contact us providing details, and we will remove access to the work immediately and investigate your claim.

Environmental performance of household waste management in Europe - an example of 7 countries

SUPPLEMENTARY MATERIAL

*Susanna Andreasi Bassi^{*1}, Thomas H. Christensen¹ and Anders Damgaard¹*

*¹Technical University of Denmark, Department of Environmental Engineering,
Bygningstorvet, Building 115, 2800 Kgs. Lyngby, Denmark*

**) Corresponding author: suan@env.dtu.dk*

Keywords: household waste management, LCA, waste hierarchy, environmental impacts, country-specific, data quality

Table of Contents

1	GOAL	3
1.1	Method, assumptions and impact limitations	3
2	SCOPE	3
2.1	Functional Unit	3
2.2	LCI modelling principles	4
2.3	Impact assessment criteria	4
2.4	System boundaries	5
2.5	Cut-off criteria	10
2.6	LCI data quality assessment	10
3	LIFE CYCLE INVENTORY ANALYSIS	12
3.1	Identification of the processes to model and planning data collection	12
3.2	Summary of the relevant assumptions and constraints during data collection	13
3.3	Fractions used in the waste composition	14
3.4	Household waste composition	15
3.4.1	Germany	17
3.4.2	Denmark	18
3.4.3	France	18
3.4.4	United Kingdom	18
3.4.5	Italy	19
3.4.6	Poland	20
3.4.7	Greece	21
3.5	Household sorting	22
3.5.1	Germany	23
3.5.2	Denmark	23
3.5.3	France	24
3.5.4	United Kingdom	25
3.5.5	Italy	26
3.5.6	Poland	26
3.5.7	Greece	27
3.6	Collection	28
3.7	Material recovery facilities	28
3.8	Waste Treatment	29
3.8.1	Recycling	31
3.8.2	Landfill for residual household waste	34
3.8.3	Landfill for inert waste	37
3.8.4	Waste-to-energy	38
3.8.5	MBT	39
3.8.6	Composting	40
3.8.7	Anaerobic digestion	42
3.9	Transport	44

3.10 Capital goods	45
3.11 Energy used	47
3.11.1 Electricity	47
3.11.2 Heat	49
3.12 Summary of the data quality	52
3.12.1 Scoring of data quality for each data set in each country	53
3.12.2 Scoring of data quality for recycling processes	61
3.12.3 Scoring of data quality for each stage in each country	62
3.12.4 Conclusions on the data quality	64
3.13 Sensitivity and scenario analysis	66
3.13.1 Perturbation analysis	66
3.13.2 Scenario analysis	67
4 RESULTS	69
4.1 Characterized results	75
4.1.1 Germany	75
4.1.2 Denmark	75
4.1.3 France	76
4.1.4 UK	76
4.1.5 Italy	77
4.1.6 Poland	77
4.1.7 Greece	78
5 DISCUSSION	79
5.1 Sensitivity scenario	79
5.1.1 Perturbation analysis	79
5.1.2 Scenario analysis	88
5.2 Data quality and sensitivity	92
5.2.1 Germany	93
5.2.2 Denmark	94
5.2.3 France	95
5.2.4 UK	96
5.2.5 Italy	97
5.2.6 Poland	98
5.2.7 Greece	99
5.3 Comparison with the European Waste Hierarchy	100
6 BIBLIOGRAPHY	106

1 Goal

The intended application of this study is to compare different environmental impacts of household solid waste management systems and to highlight the environmental “hotspots” in selected seven European countries and to determine the main differences in the management in these countries. The countries studied, namely Germany, Denmark, France, UK, Italy, Poland and Greece are meant to represent the whole EU. An indirect output of the study is an analysis on how much the results are affected by the national context and to compare them to recycling rates.

According to ILCD Handbook, the *decision-context* is essential to determine the scope and the type of LCI model. There are four different decision-context situations: A, B, C1 and C2. Situations A or “Micro-level decision support” and B or “Meso/Macro-level decision support” include the LCAs based on which decisions are taken in order to improve environmental impacts of the studied product or service. Situation C is a descriptive accounting of the analysed system. The goal of this paper is to be a monitoring study involving comparisons. For this reason this LCA is categorized as Situation C1.

The *commissioner of the study* is the department on Environmental Engineering at the Technical University of Denmark which has a long history of LCA in the waste sector and the *target audience* of deliverables are LCA and waste experts specialised in LCA.

1.1 Method, assumptions and impact limitations

The software used is EASETECH, a specialised LCA model developed by DTU (Clavreul et al., 2014) and the study has been conducted according to the requirements of ISO 14044:2006 and the ILCD Handbook. Regarding the *impacts coverage*, the results are limited to Global Warming, Freshwater Eutrophication, Marine Eutrophication, Terrestrial Eutrophication, Terrestrial Acidification, Human Toxicity carcinogenic, Human Toxicity non-carcinogenic, Eco-Toxicity, Particular Matter, Depletion of Abiotic Fossil Resources, Depletion of Abiotic Mineral Resources (reserve base). Analyses that need to consider other impacts cannot use the results from this study.

Table 1: Main constraints affecting the scope definition, LCI and LCIA phases.

Phase	Main limitations
Scope	<ul style="list-style-type: none"> - Definition of system boundaries - Setting of cut-off criteria - Setting of technological, geographical and time representativeness
Life Cycle Inventory	<ul style="list-style-type: none"> - Dimensions of the pond system - Quantities (and sometimes types) of materials used - Maintenance and disposal activities
Life Cycle Impact Assessment	<ul style="list-style-type: none"> - Modelled processes in the software GaBi - Choice of impact assessment method (hence number and types of indicators) - Choice of normalization reference - Choice of weighting factor

The *limitations of the model* include the use of EASETECH to model the system and the related impacts on long-term emissions. Different softwares are available and results can be affected by the specific modelling principles of the utilized software.

Finally, the main issue of the model is represented by the *assumptions-related limitations* generally caused by the limited and uncertain data available for each country that are analysed more in detail in the following paragraphs. For this reason, the study of the data representativeness, uncertainty, sensitivity and overall data quality is central in this LCA. And in case results of sub-processes, as the impacts due to a specific waste technology in a specific country, want to be extrapolated, a particular attention to their sources and to their quality has to be made.

2 Scope

2.1 Functional Unit

The *Functional Unit* is the management (e.g. segregation, collection, treatment and disposal) of 1 tonne of household waste in seven European countries. Due to the fact that there is a large variance in how member countries define and report MSW arising (Christensen, 2011), we decided to compare household waste where we could ensure a consistent definition of the waste.. We define household waste as “the

ordinary waste generated in the household or actually in the house from everyday activity" (Christensen et al., 2011). To simplify the comparison among the countries, garden waste, hazardous waste and WEEE are excluded from the composition together with the treatment of collected wood, textiles and batteries. Regarding plastic recycling, only PET, HDPE and soft plastic recycling are modelled. The composition of the waste explored can be seen in Table 9. The types of treatment included are waste-to-energy (WtE) and mechanical biological treatment (MBT) plants, landfills, aerobic and anaerobic digestion for source-sorted food waste and recycling of dry materials (glass, ferrous and non-ferrous metals, HDPE, PET, soft plastic, paper and cardboard).

2.2 LCI modelling principles

In agreement with the goal definition of the study and with ISO 14044:2006 recommendations for system in situation C1, attributional modelling should be used. Furthermore, according to the recommendation given by ISO 14044:2006, system expansion was privileged over allocation to handle multi-functional processes. In fact, waste systems were credited for the avoided emissions that would have had produced in the production of substituted products (Boldrin et al., 2014), as secondary material or energy. Regarding the system expansion for crediting material recovery, substitution of material has been modelled utilizing different substitution ratio for each fraction. The substitution ratios modelled depend on both the recycling technology and the quality of the secondary product.

2.3 Impact assessment criteria

The impacts coverage of this study is presented in Table 1. The selection of the characterization methods is based on the conclusions presented by EC-JRC (2011) and implemented in the ILCD v 1.0.6. Even if in the guideline an aggregated impact is used for Depletion of Abiotic Resources, results for both fossil and mineral resources based on the CML method are studied in this LCA because of their different order of magnitude. The characterized factors are then normalised in Person Equivalent (PE), which is the ratio between the actual load and the average annual load produced by one person (Boldrin et al., 2014). More information about how the normalisation factors are calculated can be found in Laurent et al. 2013. Both non-toxic and toxic impact categories are included. Land and water use are excluded because they heavily depend on the geographical location and the results would have been affected by a great uncertainty. Finally, equal weighting factors are assigned to all the impact categories in order to rank the impact scores according to their relative importance and to allow the comparison between the impacts (EC-JRC, 2011).

Table 1: Impact categories and normalisation references used in the system (Laurent et al., 2013). AE: Accumulated exceedance CTU_h : comparative toxic unit for humans. CTU_e : comparative toxic unit for ecosystem

Impact category	Abbreviation	Method	Normalisation reference	Unit
Climate Change	GW ₁₀₀	IPCC 2007	8 096	kg CO ₂ -eq./PE/year
Freshwater Eutrophication	FE	ReCiPe Midpoint	0.62	kg P-eq./person/year
Marine eutrophication	ME	ReCiPe Midpoint	9.38	kg N-eq./PE/year
Terrestrial eutrophication	TE	Accumulated Exceedance	1 150	AE/PE/year
Terrestrial acidification	AC	Accumulated Exceedance	49.6	AE/PE/year
Human toxicity, carcinogenic, W/O Long-term, DTU updated version	HT-C	USEtox	$5.42 * 10^{-5}$	$CTU_h^*/PE/year$
Human toxicity, non-carcinogenic, W/O Long-term, DTU updated version	HT-NC	USEtox	$1.1 * 10^{-3}$	$CTU_h/PE/year$
Eco-toxicity, total, W/O Long-term, DTU updated version	ET	USEtox	665	$CTU_e/PE/year$
Particulate matter	PM	Humbert 2009	2.76	kg PM _{2.5} /PE/year
Depletion of Abiotic Fossil Resources	AD-F	CML	$6.24 * 10^{-4}$	MJ/PE/year
Depletion of Abiotic Mineral Resources (reserve base)	AD-E	CML	$3.43 * 10^{-2}$	kg Sb-eq./PE/year

2.4 System boundaries

The description of the system and the system boundaries are crucial to understand the choices and assumptions made throughout the study. The system boundaries of the model are shown in Figure 1. The waste enters the system boundaries of the model after being produced by the households. The system includes waste collection, transport, waste treatments, utilization of compost and digestate and treatment of residues from a material recovery facility (MRF), WtE and MBT. It has to be noted that all the source-sorted fractions do not include any impurities, and this explains the lack of residuals from composting and AD facilities. Dry recyclables are directed first to a MRF and then to recycling plants. Furthermore, the capital goods are included for the transport and for all waste treatment plants (landfill, MRF, recycling facilities, WtE, MBT, composting and AD). Transport of waste take place between life cycle stages: between collection and MRF, between MRF and waste treatment facilities and between waste treatment facilities and recycling/disposal facilities of their sub products.

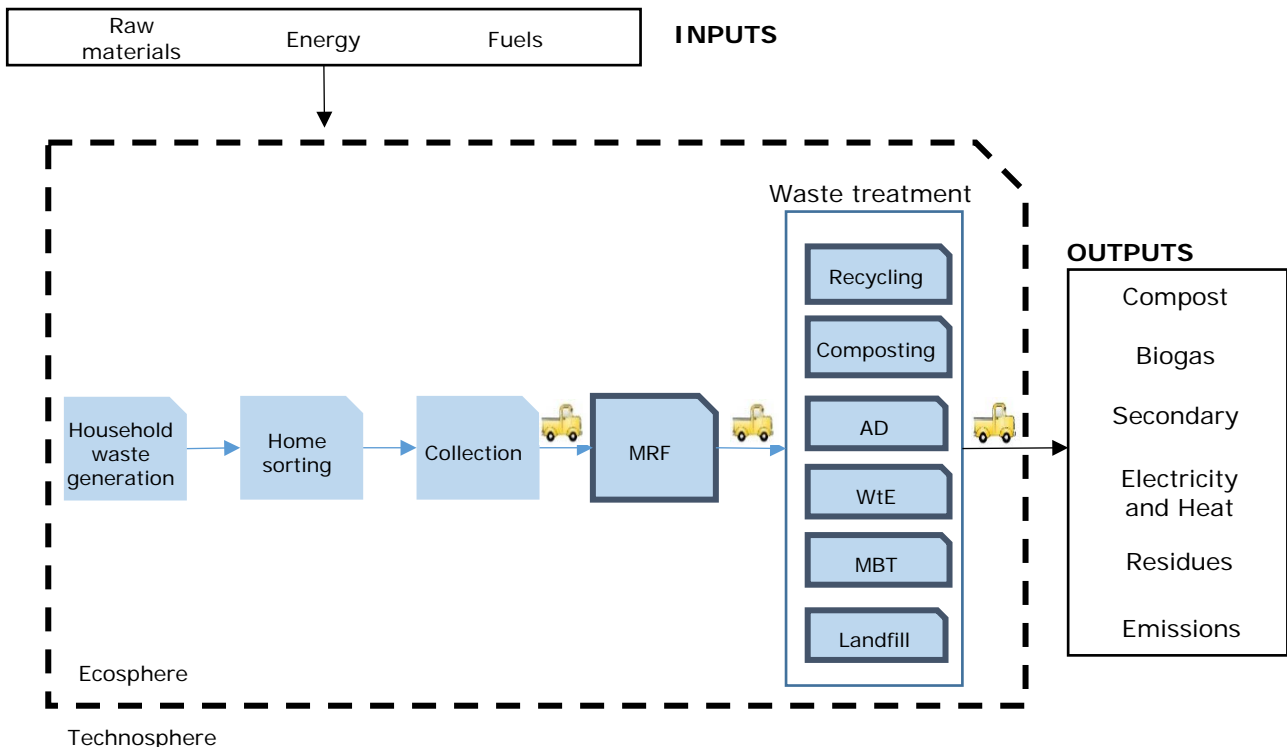

Figure 1: System boundaries of the LCA study. The truck indicates the inclusion of the waste transportation. The thicker border indicates the inclusion of capital goods in the process

In order to have a more clear idea of the processes modelled, Figure 2 - Figure 5 graphically show the system modelled in each country. To be noticed that the processes with dotted lines are the substituted material/energy production.

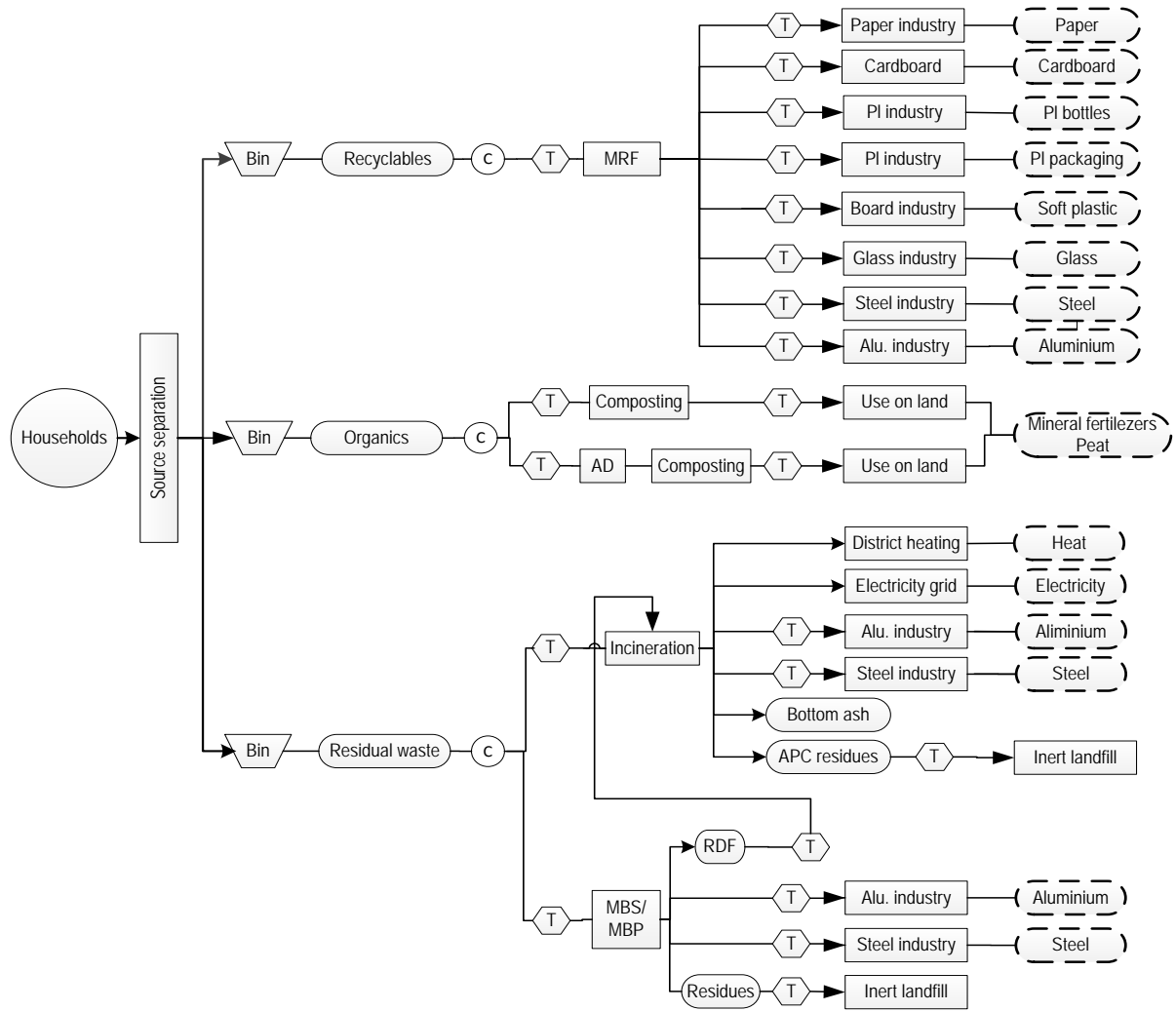

Figure 2: System modelled in Germany

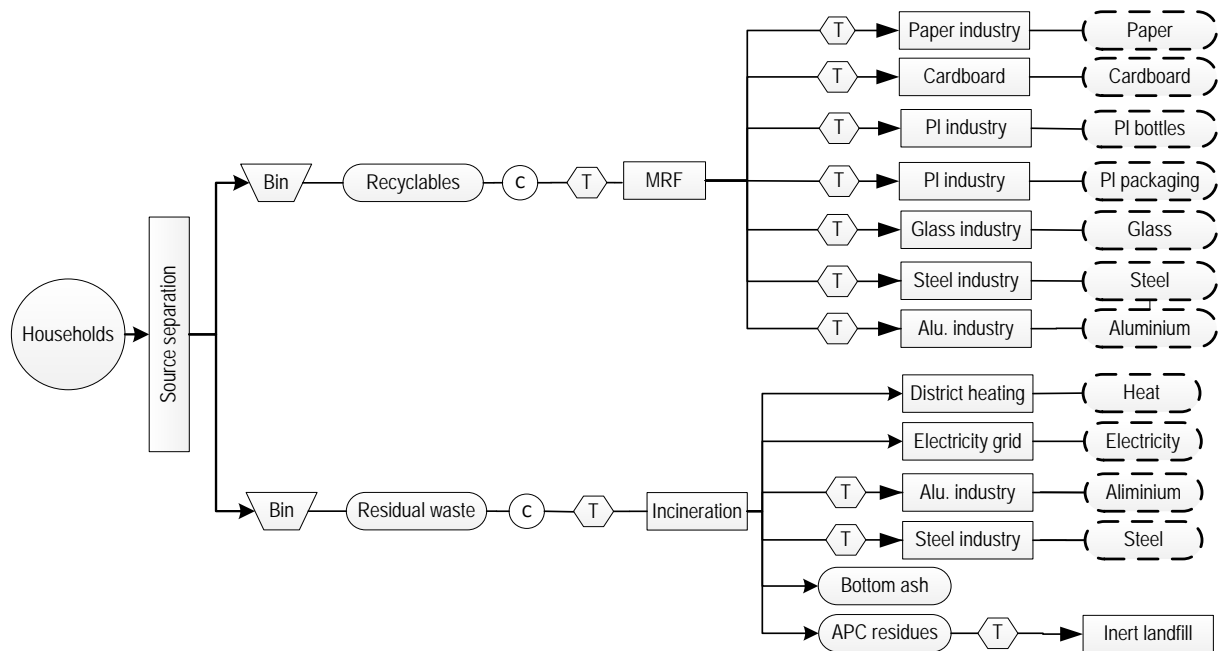

Figure 3: System modelled in Denmark

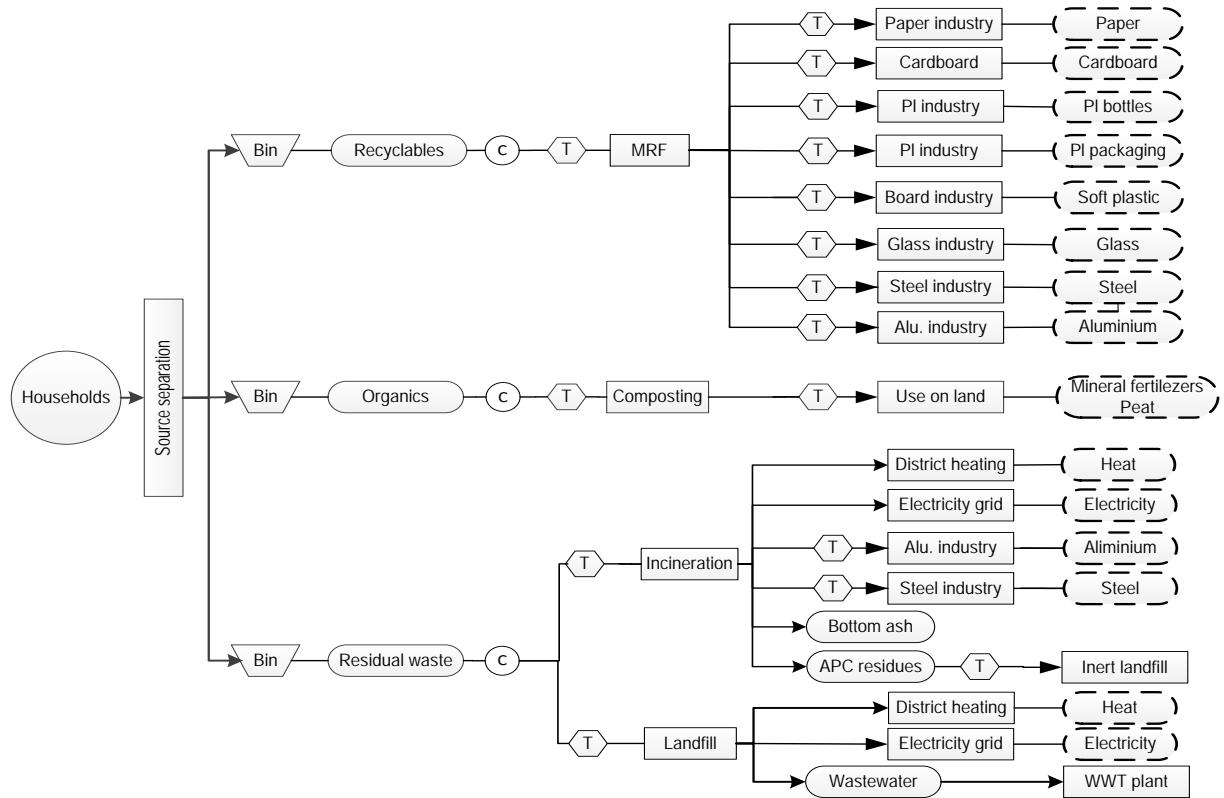

Figure 4: System modelled in France

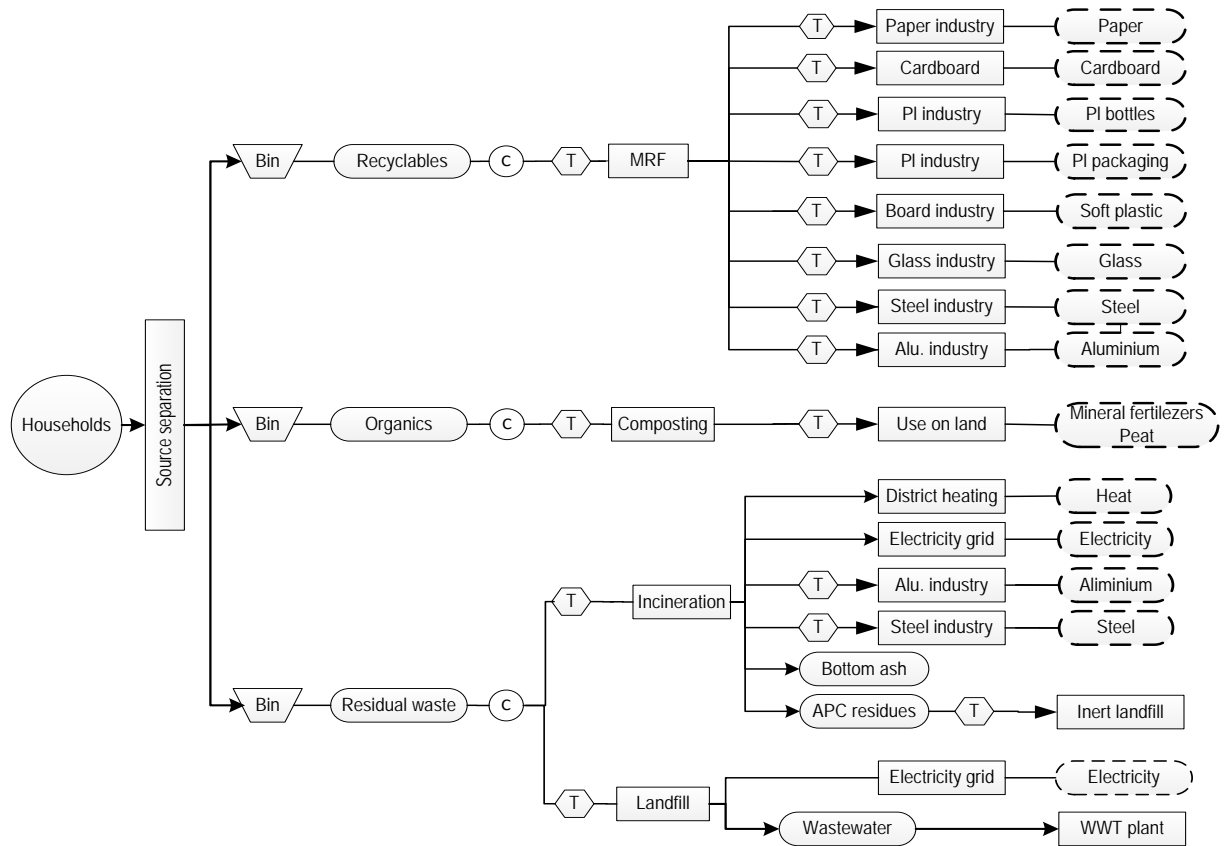

Figure 5: System modelled in UK

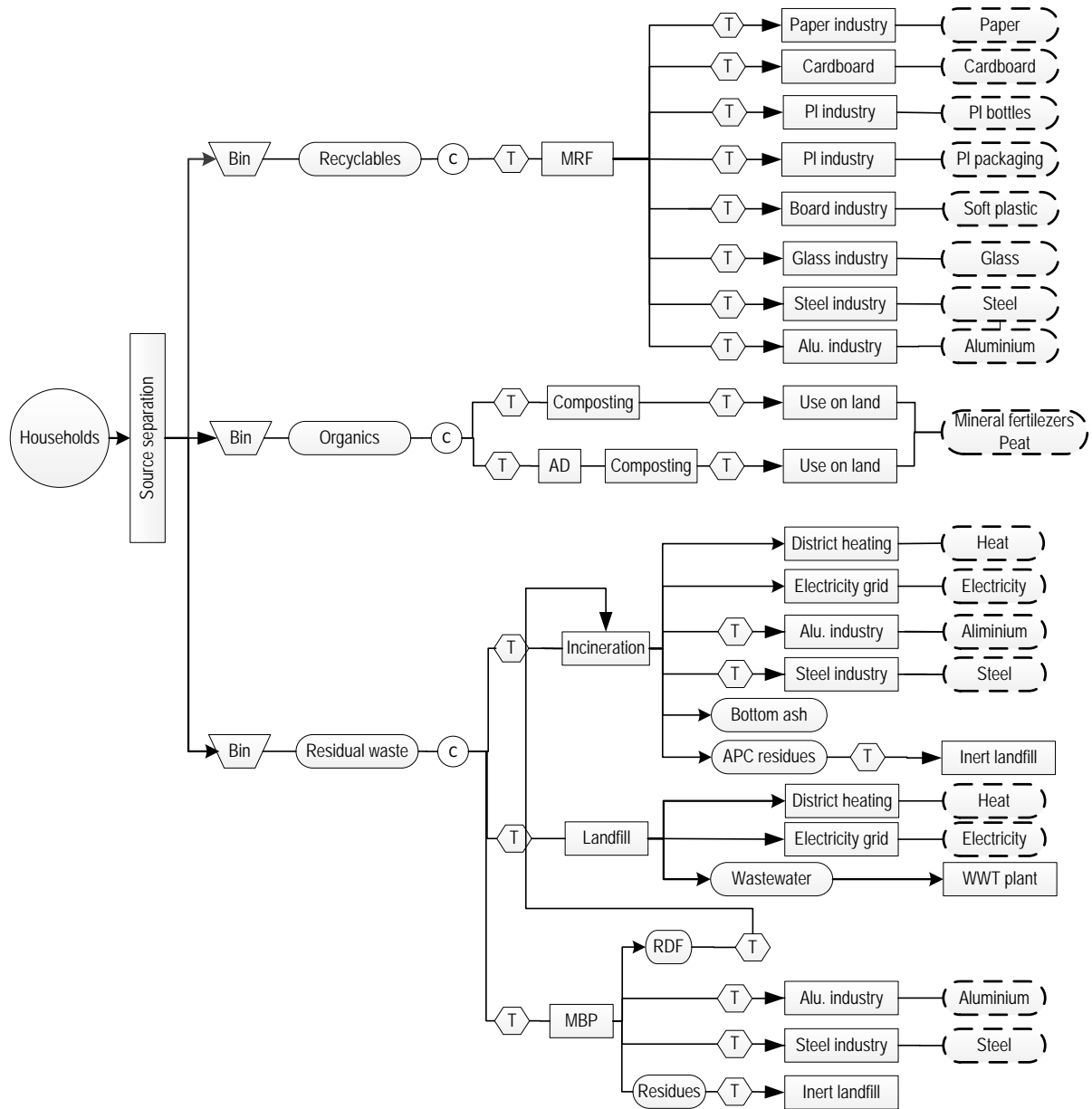

Figure 6: System modelled in Italy

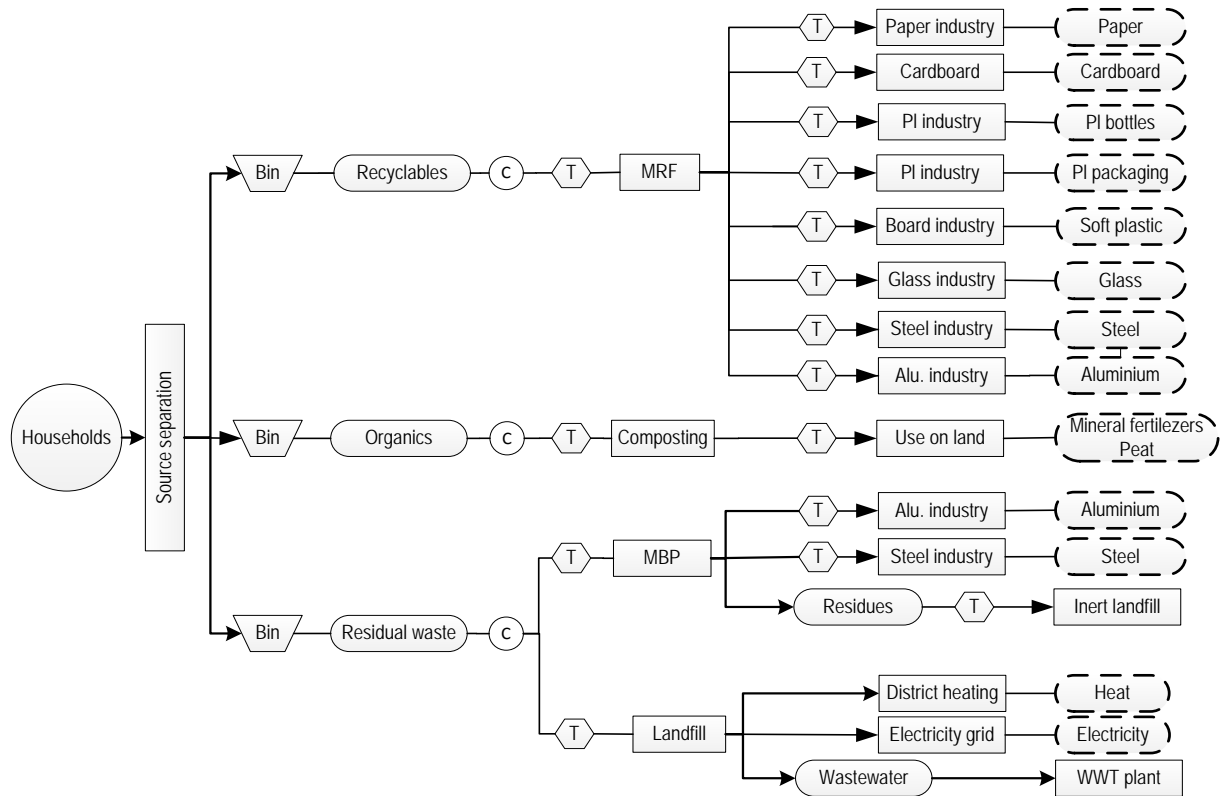

Figure 7: System modelled in Poland

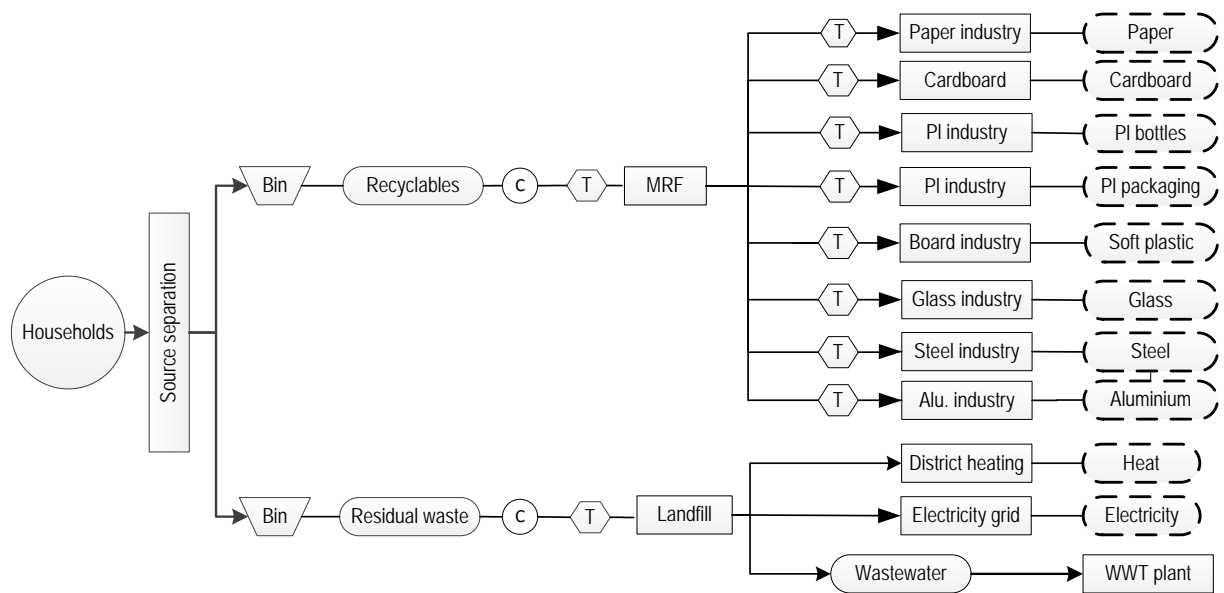

Figure 8: System modelled in Greece

2.5 Cut-off criteria

The cut off criteria for each stage and their justification are summarized in Table 2.

Table 2: Summary of the cut-off criteria

Stage	Cut off criteria	Justification
Household waste generation	WEEW, garden waste, bulky waste, hazardous waste (excl. batteries)	Not focus of this paper
	Bins for the collection	Considered the same in all the countries; therefore they can be neglected during the comparison
Household sorting	Source-sorted wood, textiles and batteries	Not focus of this paper
	Waste collected in civic amenities	Not focus of this paper
	Source-sorted composite recycling	Little data found in literature about the recycling process and little percentage of composite material in the overall household waste
	Only PET and HDPE recycling is considered regarding plastic bottles and other plastic packaging	Little data found in literature about the other recycling processes and difficulty to find comparative compositional data of the other materials.
Collection	Capital good for bins and for collection vehicles	Considered the same in all the countries; therefore they can be neglected during the comparison
MRF	-	-
Waste treatment	For each country, the treatments that involve uncertain small percentage of the total waste are neglected	Considered negligible due to the size of the model
	Treatments of the residues from the recycling processes	Lack of consistent information
Recycling	Emissions from the secondary production of PET, HDPE and soft plastic.	Quantifiable with difficulty in Rigamonti (2007)
Landfill	-	-
WtE	Treatment of wastewater and bottom ashes	Wastewater is assumed to be reutilised internally, and bottom ashes because of minor importance (explained later).
	Transport of the wastewater from the WtE plant to the WWT plant	Considered negligible
MBT	-	-
Composting	-	-
AD	-	-
Transport	-	-

2.6 LCI data quality assessment

Due to the high number of data collected, a method to keep track of and to quantify their quality was performed. The method developed by Weidema and Wesnæs (1996) was used for each parameter (Table 3). This method includes 5 categories that are the same ones defined in the ILCD: technological, geographical and time-related representativeness, completeness and reliability. Each category is assigned a value from 1 to 5, where one indicates robustness and 5 lack of data. The quality scoring matrix is shown in Table 3. EC-JRC (2011) clearly states that the importance of each category is case specific, but in this paper the categories are equally weighed to avoid very uncertain weighing. The average is then calculated for each parameter as an average of the categories, and then for each stage of the model as an average of its parameters and finally for each country as an average of its stages. In this way, it is hoped to have clearly displayed the data quality for both a detailed and a general analysis that is very useful during the interpretations of the results.

Table 3: Quality scoring matrix (Weidema and Wesnæs, 1996)

Indicator scores / category	1	2	3	4	5
Technological correlation	Data from enterprises processes and materials under study	Data from processes and materials under study but from different enterprises	Data from processes and materials under study but from different technology	Data on related processes or materials but from same technology	Data on related processes or materials but from different technology
Geographic al correlation	Data from area under study	Average data from larger area in which the area under study is included	Data from area with similar production conditions	Data from area with slightly similar production conditions	Data from unknown area or area with very different production conditions
Temporal correlation	Less than 3 years of difference to year of study	Less than 6 years difference	Less than 10 years difference	Less than 15 years difference	Age of data unknown or more than 15 years of difference
Completeness	Representative data from an adequate sample of sites over an adequate period	Representative data from a smaller number of sites over an adequate period	Representative data from an adequate number of sites but over a shorter period	Representative data from a small number of sites over a shorter period or inadequate data from adequate number of sites	Unknown or incomplete data from a small number of sites
Reliability	Verified data based on measurements	Verified data based partly on assumptions or non-verified data based on measurements	Unverified data based partly on assumptions	Qualified estimate	Unqualified estimate

The overall data quality or Data Quality Rating (DQR) for each process was calculated summing the value of each quality indicator weighting the weakest quality value 5-fold (EC-JRC, 2011):

$$DQR = \frac{TeR+GR+TiR+C+P+M+Xw*4}{i+4} \quad (\text{EC-JRC, 2011}), \text{ where:}$$

- DQR: Data Quality Rating
- TeR, GR, TiR, C, P, M: data quality indicators in EC-JRC (2011), where TeR is the Technological representativeness, GR is the geographical representativeness, TiR is the time-related representativeness, C is the completeness and P is the precision uncertainty. In this paper, the indicators are based on Weidema and Wesnæs (1996) as previously explained.
- Xw: weakest quality level obtained, that is equal to the highest numeric value among the data quality indicators
- i: number of data quality indicators

DQR can be used to identify the quality level of a data set according to Table 4 (EC-JRC, 2011).

Table 4: Overall quality level of a data set according to the DQR (EC-JRC, 2011)

Overall data quality rating (DQR)	Overall data quality level
1.6	High quality
> 1.6 to 3	Basic quality
>3 to 4	Data estimate

3 Life cycle inventory analysis

In this phase of the LCA, a detailed explanation of the calculations needed to identify the elementary flows of the system is performed, together with an elucidation of the system modelling with EASETECH.

3.1 Identification of the processes to model and planning data collection

In order to understand the types of data to collect, it is important to subdivide the main model in the processes (or stages) that need to be modelled. The system is divided in six main processes and the process "waste treatment" is divided in the same way in six sub processes. This schematization is very useful to analyse data quality, to summarize the assumptions behind each process and to study the overall uncertainty of data and processes. In order to avoid misunderstanding of what each data represents, a short explanation is added in Table 5.

For the stage "Recycling", an average of the following data for each material was calculated: substitution ratio, substituted material (quality of the process imported from ecoinvent/EASETECH), energy, ancillary materials consumption, emissions to air and water, fate of residues and capital goods 8 process imported from ecoinvent).

Table 5: Processes to model and data to collect

Stage / process to model	Data to collect
Household waste generation	<ul style="list-style-type: none"> Household waste composition: percentage of each fraction Chemical composition
Household sorting	<ul style="list-style-type: none"> Household sorting efficiency: fractions collected and percentages of collection Composition of the collected fractions: for example how much green, clear and brown glass is in the glass fraction in case no data are available Types of collection schemes: one stream, two streams or co-mingled
Collection	<ul style="list-style-type: none"> Fuel consumption: litres of fuel consumed per km
MRF	<ul style="list-style-type: none"> Sorting efficiencies Electricity, diesel and wire consumption Capital goods: process imported from ecoinvent
Waste treatment	<ul style="list-style-type: none"> % of residual waste going to different treatments: WtE, landfill, MBP and MBS % of food waste going to different treatments: composting and AD
Recycling	<ul style="list-style-type: none"> Paper Cardboard Glass PET HDPE Soft Plastic Al Steel
Landfill	<ul style="list-style-type: none"> Construction and operation: capital goods Decay rates and order of degradation Weather conditions Addition of trace substances (concentration of trace gasses in the landfill gas) Gas collection rate: % of the produced gas that is collected Gas utilization rate: % of the collected gas that is flared and that is utilized for energy consumption Types of gas utilization (electricity or heat) Emissions from different landfill gas treatment technologies Oxidation rates in the top cover (daily, intermediate and final cover) Net infiltration rate (leachate generation) Concentration of trace substances in the leachate Collection efficiency of the leachate Removal efficiencies of the leachate Natural leachate attenuation rates
Mineral landfill	<ul style="list-style-type: none"> Construction and operation: capital goods Process: leachate and emissions
WtE	<ul style="list-style-type: none"> Transfer coefficients Emissions to air and ancillary materials consumption

	<ul style="list-style-type: none"> Metals recovery efficiency: % of steel and aluminium recovered from the bottom ash Net thermal efficiency for electricity and heat production Capital goods: process imported from ecoinvent
MBP/MBS	<ul style="list-style-type: none"> Transfer coefficients Energy and ancillary materials consumption Emissions to air and water Capital goods: process imported from ecoinvent
Composting	<ul style="list-style-type: none"> Transfer coefficients Energy and ancillary materials consumption Emissions to air and water % of compost going to different destinations: to agriculture, gardening or other. Typology of soil where the compost is applied: loam or sandy Capital good: process imported from ecoinvent
AD	<ul style="list-style-type: none"> Transfer coefficients Energy consumption Ancillary material consumption Emissions to air and water Electricity and heat efficiency % of composted digestate going to different destinations: to agriculture, gardening or other. Type of soil where the digestate is applied: loam or sandy Capital goods: process imported from ecoinvent
Transport	<ul style="list-style-type: none"> Types of tracks: capacity and emissions standards (e.g. EURO5) Distance: km between two different stages Capital goods: types of processes imported from ecoinvent

3.2 Summary of the relevant assumptions and constraints during data collection

Due to the number of data collected during the LCI, a list of the most relevant assumptions and constraints for each stage of the system is shown in Table 6. A more detailed explanation can be found afterwards.

Table 6: Summary of the relevant assumptions and constraints for each stage of the system

Stage	Main assumptions
Household waste generation	<ul style="list-style-type: none"> In general, a national report is used for the main fractions and several papers are the basis for the detailed composition. Even if the paper are from different years, they are merged in the most coherent way possible; Garden waste, WEEE and hazardous waste are always excluded from the composition found in literature because not the focus of the study. The operation of subtraction of these fractions could have affected the results. All the fractions relative to recyclables (paper, cardboard, soft plastic, plastic bottles, other plastic packaging, clear glass, green glass, brown glass, non-ferrous metals, ferrous metals) include only recyclable material, the non-recyclable part is added to combustibles (plastic and paper) or to non-combustibles (glass and metal). This operation is affected by a great uncertainty because the composition analysis of the recyclables was conducted very differently in each country. Due to this reason, the percentage of actual recyclable fractions could be overestimated in some countries and underestimated in others. The polymeric composition of plastic included only PET and HDPE. Due to the uncertainty of the compositional analysis found in literature, the percentage of recyclable PET and HDPE could be overestimated. The model includes only the treatment of paper, cardboard, plastic, glass and metals. Separate collection and treatment of wood, textiles and batteries is excluded (the quantities collected were subtracted from the composition).
Household sorting	<ul style="list-style-type: none"> Waste collected in civic amenities sites is not included. Unfortunately, it was not always clear when sorting efficiencies and material collected included the civic amenities. To avoid distortions, data were treated in the more coherent way possible. The composition of the collected material (e.g. division of plastic in PET, HDPE and soft plastic) is assumed to be the same as the generated fraction, if further information are not found. Per example

		the percentage of PET, HDPE and soft plastic in the plastic fraction are the same in both the generated and the source-sorted collected fraction. This assumption was valid in all the countries but FR and UK where a compositional analysis of the collected material was carried on.
		<ul style="list-style-type: none"> All the source-sorted fractions are clean, thus the quality of the second material produced are not affected by impurities. In reality, impurities have a big impact on the quality of the recycling process.
Collection	-	
MRF		<ul style="list-style-type: none"> The sorting efficiencies are not affected by the composition of the material entering the MRF since no impurities are modelled.
Waste treatment	-	
		<ul style="list-style-type: none"> European average processes are modelled for each country. The substitution ratio is based mainly on Italian plants. The sorting efficiencies are not affected by the composition of the material entering the MRF since no impurities are modelled.
	Recycling	<ul style="list-style-type: none"> Regarding plastic recycling, only PET, HDPE and soft plastic recycling are modelled due to the lack of coherent data for the other polymeric components. Only one substituted material is considered for each recycling process and the choice of the substituted material is very important regarding paper recycling.
	WtE	<ul style="list-style-type: none"> Due to the lack of coherent data, WtE plants are modelled in the same way for all the countries, even if it is known that there are important differences. In particular, the process is based only on Danish and this is particularly influent regarding environmental emissions and metals recovery efficiency.
	MBT	<ul style="list-style-type: none"> Only two types of MBT plant are modelled for Europe and these do not include anaerobic digestion and are based on very uncertain data.
Composting	-	
AD	-	
	Landfill	<ul style="list-style-type: none"> Due to the complexity of the process, similar landfills are modelled for all the countries.
Transport		<ul style="list-style-type: none"> The same types of trucks EURO5 and the same distances are modelled in all Europe.

3.3 Fractions used in the waste composition

The material fractions used in this paper are based on EASETECH database that include chemical composition and LHV per each fraction.

To allow reproducibility of the results, the fractions modelled and the materials included in each fraction are stated in Table 7.

Table 7: Fractions used in the model

Name used through this paper	Name of the fraction in EASETECH	Materials included
Food waste	Vegetable food waste	Vegetable and animal food waste
Paper	Office paper	All recyclable paper
Cardboard	Paper and carton containers	All recyclable cardboard
Composite material	Juice cartons (carton/plastic/aluminium)	All composite material
Soft plastic	Soft plastic	Soft plastic, plastic sheets
Plastic bottles	Plastic bottles	All plastic bottles
Other plastic packaging	Hard plastic	All the recyclable plastic packaging (excluding bottles)
Diapers, sanitary towels, tampons	Diapers, sanitary towels, tampons	
Wood	Wood	
Textiles	Textiles	
Other combustibles	Other combustibles	Generic combustibles
Clear glass	Clear glass	Only recyclable clear glass
Green glass	Green glass	Only recyclable green glass
Brown glass	Brown glass	Only recyclable brown glass
Non-ferrous metals	Beverage cans (aluminium)	Non-ferrous packaging and non-packaging
Ferrous metals	Food cans (tinplate/steel)	Ferrous packaging and non-packaging
Ash	Ash	

Batteries	Batteries	
Other non-combustibles	Other non-combustibles	Generic non-combustibles

3.4 Household waste composition

The model strongly depends on household composition. One of the main limitations of LCA is a need of disaggregated inputs, but the data available from national reports and EUROSTAT are often aggregated and it is not possible to part them easily. Some of the main parameters that vary from country to country are: quality and sources of data, methodology and robustness of compositional analysis and degree of inclusion of commercial waste (Gibbs et al., 2014), fractions included, etc.

The generic and the detailed composition of the household waste for each country are presented in Table 8 and Table 9. The former helps the comparison among countries, while the latter is the composition modelled. Sometimes, the composition found in literature included garden waste that was later excluded because not the focus of the paper. In order to keep track of how the data were calculated, Table 9 shows the composition both with and without garden waste. Afterwards follows the comprehensive data collection for each country.

The general assumptions and cut-off criteria for the calculation of household waste composition are listed below:

- If no data are found regarding household waste, municipal waste data are used as in Germany, France, Italy, Poland and Greece;
- In general, a national report is used for the main fractions and several papers are the basis for the detailed composition. Even if the paper are from different years, they are merged in the most coherent way possible;
- Garden waste, WEEE and hazardous waste are always excluded from the composition found in literature because not the focus of the study;
- All the fractions relative to recyclables (paper, cardboard, soft plastic, plastic bottles, other plastic packaging, clear glass, green glass, brown glass, non-ferrous metals, ferrous metals) include only recyclable material, the non-recyclable part is added to combustibles (plastic and paper) or to non-combustibles (glass and metal). This operation is affected by a great uncertainty because the composition analysis of the recyclables was conducted very differently in each country. Due to this reason, the percentage of actual recyclable fractions could be overestimated in some countries and underestimated in others.
- Glass is split in 3 equal parts in clear glass, green glass and brown glass in case more detailed data were not found as in Germany, Denmark, Italy and Greece;
- The polymeric composition of plastic included only PET and HDPE. Due to the uncertainty of the compositional analysis found in literature, the percentage of recyclable PET and HDPE could be overestimated.
- The model includes only the treatment of paper, cardboard, plastic, glass and metals. Separate collection and treatment of wood, textiles and batteries is excluded (the quantities collected were subtracted from the composition).

Table 8: Generic composition

	DE %	DK %	EL %	FR %	IT %	PL %	UK %
Food waste	22.62	32.00	32.41	25.85	31.55	25.56	26.72
Paper/Cardboard	25.71	28.43	23.61	22.66	21.68	15.59	27.28
Plastic	14.83	1.80	11.85	9.20	11.10	12.23	10.55
Metal	7.43	2.39	4.86	3.13	5.29	2.86	3.90
Glass	7.00	9.00	5.32	11.74	9.44	12.47	8.18
Batteries	0.09	0.13	0.20	0.03	0.07	0.13	0.10
Other	23.07	26.24	21.74	27.38	20.87	31.15	23.27

Table 9: Detailed composition of the household waste with and without garden waste (GW). The composition without garden waste is modelled in this paper. *Due to the lack of information, all the plastic packaging is modelled as "Other Packaging Plastic"

	DE		DK		FR		UK		IT		PL		EL	
	With GW	Without GW	With GW	Without GW	With GW	Without GW	With GW	Without GW	With GW	Without GW	With GW	Without GW	With GW	Without GW
Vegetable food waste	19.77	22.62		32.00	24.53	25.85	22.45	26.72	27.58	31.55	22.36	25.56	28.17	32.41
Office paper	13.24	15.15		23.54	14.61	15.40	17.85	21.24	13.57	15.52	9.38	10.73	17.45	20.07
Cardboard	9.22	10.55		4.89	6.90	7.27	5.07	6.04	5.38	6.15	4.26	4.87	3.08	3.54
Composite material	4.14	4.74		2.42	1.40	1.48	0.00	0.00	5.81	6.65	3.60	4.11	0.00	0.00
Soft plastic	8.77	10.04		0.78	3.61	3.81	4.70	5.60	4.91	5.62	7.01	8.01	7.05	8.12
Plastic bottles	-*	-*		-*	2.38	2.51	2.25	2.67	4.16	4.76	2.80	3.20	-*	-*
Other packaging PI	3.53	4.04		1.02	2.73	2.88	1.91	2.27	0.63	0.72	0.89	1.02	3.24	3.73
Yard waste, flowers	12.61	-		-	5.12	-	15.98	-	9.8	-	12.53	-	13.08	-
Diapers, tampons, etc.	1.87	2.14		4.98	8.62	9.09	4.42	5.26	2.7	3.11	1.58	1.81	3.01	3.46
Wood	0.09	0.10		0.29	0.30	0.32	0.86	1.03	4.1	2.05	0.40	0.46	5.03	5.79
Textiles	2.56	2.93		1.49	1.93	2.03	2.14	2.55	2.6	2.52	2.39	2.73	1.01	1.16
Other combustibles	4.04	4.63		13.47	6.91	7.28	7.84	9.33	3.56	4.07	5.83	6.66	5.10	5.87
Clear glass	2.04	2.33		3.00	4.23	4.45	4.15	4.93	2.75	3.15	7.64	8.73	1.54	1.77
Green glass	2.04	2.33		3.00	3.46	3.64	2.11	2.51	2.75	3.15	1.64	1.87	1.54	1.77
Brown glass	2.04	2.33		3.00	3.46	3.64	0.62	0.73	2.75	3.15	1.64	1.87	1.54	1.77
Non-Fe cans	2.67	3.05		1.17	0.57	0.60	1.17	1.40	2.26	2.58	0.66	0.75	1.30	1.50
Ferrous cans	3.83	4.38		1.22	2.40	2.53	2.10	2.50	2.37	2.71	1.84	2.11	2.92	3.36
Ash	5.04	5.77		0.25	0.94	0.99	1.47	1.75	0.92	1.05		10.57	0.24	0.28
Batteries	0.07	0.09		0.13	0.03	0.03	0.09	0.10	0.09	0.07	9.25	0.13	0.17	0.20
Non-combustibles	2.42	2.77		3.34	5.87	6.19	2.81	3.35	1.25	1.43	0.11	4.80	4.51	5.18

3.4.1 Germany

Gibbs et al. 2014 published the composition of MSW in Germany on data received by the Federal Environmental Agency (Table 10) of which WEEE and hazardous were excluded because not considered in this paper. Since no official data were found regarding HSW, MSW data were used. The fraction "paper/cardboard" was split in 59% paper and 41% cardboard; metals in 41% non-ferrous and 59% ferrous material (SHC Sabrowski-Hertrich-Consult GmbH, 2010); "plastic" in 54% soft plastic, 26% hard packaging plastic, 21% other plastic added in combustibles (Witzenhausen-Institut für Abfall Umwelt und Energie GmbH, 2012). The "others" was divided in 68% composite material, 31% in sanitary material and 1% batteries, utilizing the data found in GIB Gesellschaft für Innovationsforschung und Beratung mbH Berlin (2009). The packaging glass is 86% of the glass fraction (SHC Sabrowski-Hertrich-Consult GmbH, 2010) and it is assumed to be composed in equal part in clear, green and brown glass. The non-packaging glass is added to the non-combustibles with the inert. The "fines" coincide with ashes.

Table 10: Municipal waste composition in Germany (Gibbs et al., 2014)

Material	%
Food	18.9
Garden waste	12
Wood	3.2
Paper/cardboard	21.5
Textiles	2.6
Glass	6.7
Metals	6.1
Plastics	15.6
WEEE	1.5
Hazardous	0.2
Fines	4.7
Inerts	1.2
Other	5.7

From this composition, the wood and the textiles collected need to be subtracted because they are not modelled in this paper: in 2012, Germany produced 34 226 Mtons of household waste (excluded hazardous and bulky waste) and collected 126.1 and 1 122 Mtons of textiles and wood, respectively (Statistisches Bundesamt Wiesbaden, 2014).

The polymeric composition of hard plastic is based on the average composition of input material in plastic sorting facilities in Germany (Jansen et al., 2012) considering only HDPE and PET and adding PP to the combustibles (Table 11).

Table 11: Average composition of the input material for the sorting process in Germany

	% tot plastic input material (Jansen et al., 2012)	% tot rigid plastic
PP rigid	10	16
HDPE rigid	23	36
PET rigid	31	48
Films	9	
PS and EPS	6	
Black plastics	2	
non-packaging plastics	7	
Residue	14	
TOT	100	100

The final composition was then normalized to 100%.

3.4.2 Denmark

The data was found in the EASETECH database and the datasets are based on residual waste and separately collected glass and paper waste. The distribution of material fractions is a weighted average of single-family and multi-family houses. Residual waste from the compositional campaign reported in Petersen and Domela (2003) in has been merged to the current material fractions of the model.

While aggregating the fractions, the following principles are used:

- Non packaging metals are constituted of 54% ferrous and 46% non-ferrous material (Edjabou et al., 2015)
- All the recyclable packaging plastic was summed in only one fraction, because the polymer composition for Danish collected plastic was available only for the generic "plastic packaging" and not for plastic bottles. This assumption is supported by the fact that the majority of Danish plastic bottles are collected separately through the bottles return system, thus, they leave the household solid waste management system.

It has to be noted the much lower percentage of recyclable plastic in the Danish household composition compared to the other countries. This could be justified by the methodology followed in the waste composition analysis in the Danish case. In fact, the non-recyclable plastic percentage was found to be 5.12%.

The Danish polymer composition of plastic is shown in Table 12 (Edjabou et al., 2015). Since, this paper only includes PET and HDPE recycling, the packaging plastic is assumed to be 46% PET and 56% HDPE.

Table 12: Polymer composition of packaging plastic (Edjabou et al., 2015) *calculated in this paper

	% of the total waste			% of the tot packaging plastic
	Single Families	Multi Families	Average *	Average *
PET	1.1	0.6	0.85	16.5%
HDPE	0.9	1.1	1	19.4%
PVC		0.5	0.5	9.7%
PP	1.4	0.4	0.9	17.5%
PS	0.4	1.2	0.8	15.5%
Unspecified	1.4	0.8	1.1	21.4%

The final composition was then normalized to 100%.

3.4.3 France

The composition of French waste derives from a municipal waste characterization campaign conducted in 2007 by the French Environment and Energy Management Agency (ADEME, 2010a). Garden waste was excluded from the composition and the only sub-fraction of hazardous waste included was "battery".

The fine material represents 12% of household waste, and is composed of 60% organic waste, 13% glass, 19% of non-combustible (e.g.: sand, soil, pottery shards, etc.) and 8 % of material between 0-8 mm that could not be characterized (ADEME, 2010a) and was added to the ashes.

The polymer composition of bottles was found in the same campaign: 68% PET and 32% polyolefin. All the polyolefin bottles are assumed to be made of HDPE. The other plastic packaging is composed by 64% of PET, PS, PP (assumed only PET), 23% of PE, PSE and PVC (assumed all HDPE) and 13% others (added to combustibles) based on (ADEME and Eco-Emballages et Ecofolio, 2014).

The final composition was then normalized to 100%.

3.4.4 United Kingdom

In 2010/2011, Defra conducted a compositional analysis in England to present the estimates for local authority collected waste in England (Resourcefutures, 2013). The composition for both the household waste and the kerbside recycling used in this paper are taken from this study.

The differences with the data published are as follow:

- Exclusion of garden waste, WEEE and hazardous waste (except batteries)
- Subtraction of 227Mt of textiles collected in 2013 out of 14 702 Mt of household waste (including garden waste and excluded bulky, WEEE, special collections and civic amenities) (DEFRA, 2014a).
- The plastic polymer composition is shown in Table 13 and all the other fractions but HDPE and PET are added to the combustibles

In 2014, the population of England was equal to 53.9 million, about 84% of the overall UK population (Office for National Statistics, 2014), thus the Defra paper is considered representative of the entire country.

Table 13: Packaging plastic composition in UK, the percentages are calculated from the data published in (WRAP, 2015). The composition of the other plastic packaging is assumed to be the same as Pots, tubs and trays in the paper.

Plastic bottles	%
PET	66.87%
HDPE	31.73%
Other	1.41%
Hard plastic packaging	%
PET	59.17%
HDPE	
other	40.83%

The final composition was then normalized to 100%.

3.4.5 Italy

No official data were found for household waste. The generic composition of municipal waste in Italy in 2013 is based on the results published in the National Report on Municipal Waste in 2014 (ISPRA, 2014) showed in Table 14. Bulky and WEEE waste were excluded. The "Selective" fraction is composed of 21% of batteries and 79% of other hazardous waste not included (ISPRA 2014), thus only 21% of this fraction was included.

The detailed fractions are then calculated based on two studies conducted on the residual waste in the municipalities of Ancona (Central Italy) and Naples (Southern Italy) published by Stella (2013) and NATURA srl (2012), respectively. Plastic composition was estimated from Rigamonti et al. (2014). The fraction "paper/cardboard" is composed of 55% paper, 22% cardboard and 23% composite material; "plastic" of 39% soft plastic, 33% bottles, 5% other plastic packaging and 23% non-recyclable (added in combustibles), "metal" of 49% non-ferrous material and 51% ferrous material and the detailed glass composition is not known, thus it was split in three equal parts in clear, green and brown glass. The organic was split in 74% food and 26% garden waste. Finally, "Other" was split in 44% non-combustibles, 23% combustibles and 33% ashes.

Finally, out of 27 251 Mt of municipal waste produced in Italy (excluding bulky, WEEE and hazardous waste), 56.49 Mt of wood and 15.62 Mt of textiles were collected in 2013 (ISPRA, 2014) and subtracted from the respective fractions because their treatment is not modelled. Furthermore, 39.89 Mt of "Selective" were collected and 21% of this fraction (the same composition was assumed for the generated and for the collected fraction) was subtracted from the batteries in the HSW composition. The polymer composition of the plastic fraction is based on Rigamonti et al. (2014) and shown in Table 15.

Table 14: Estimated municipal waste composition in Italy (ISPRA 2014) excluding the fractions not modelled in this report. *refers to drugs, containers for toxic and flammable products (e.g. spray), batteries and accumulators, paints, inks

Fraction	Waste composition (ISPRA, 2014) %
Organic	34.4
Paper/Cardboard	22.8
Glass	7.6
Plastic	11.6
Metals	4.3
Wood	3.8
WEEE	2.4
Bulky waste	5.1
Textiles	2.4
Selective*	0.4
Diapers / absorbent materials	2.5
Other	2.6

Table 15: Polymer composition of Plastic in the MSW in Italy (Rigamonti et al. 2014)

	PET [% of the tot]	HDPE [% of the tot]	LDPE [% of the tot]	Mix [% of the tot]
Bottles	25	8		
Soft plastic			39	
Hard plastic		5		
Non-recyclable				23
	PET [%]	HDPE [%]		
Plastic bottles	76	24		
Hard plastic		100		

The final composition was then normalized to 100%.

3.4.6 Poland

The generic composition of MSW generated in Poland in 2008 is given by the National Waste Management Plan for 2014 (Ministry of Environment, 2010) from which the bulky waste and the waste from greenery were excluded (Table 16). The category "hazardous waste" was assumed to consist 16% of batteries following the compositional analysis carried out in UK (Resourcefutures, 2013) since no information were found for Poland. The detailed composition was found in Boer et al. (2010). It has to be noted that the authors considered this study affected by uncertainty because the results from Polish cities showed great variability. Since it was the only study found, it was used anyway for the composition of paper/cardboard, plastic and glass. Szpadt et al. (2005) studied the packaging and non-packaging metal in the household waste Wrocław and Krakow. The fraction paper/cardboard was split in 69% paper and 31% cardboard, the plastic in 51% plastic sheet (*soft plastic*), 14% PET bottles, 6% PE bottles, 6% food packaging (*other plastic packaging*) and 22% other types (added in *combustibles*); the glass in 71% white and 29% coloured glass (divided in equal parts between green and brown) and the metals in 74% ferrous and 26% non-ferrous materials. The "other" is divided in *combustibles* (64%) and *diapers, sanitary towels, tampons* (36%). The "fines" coincides with *ashes*.

The organic waste is assumed to be split in 64% food and 36% garden waste (Gibbs et al., 2014).

Table 16: Municipal waste composition in 2008 in Poland (Ministry of Environment, 2010)

Fractions	* 1000 t
Paper and cardboard	1520.5
Glass	1216.3
Metal	279
Plastics	1533.6
Multi-material waste	401.2

Kitchen and garden waste	3888.6
Mineral waste	467.9
Fraction <10mm	1030.7
Textiles	325.8
Wood	44.8
Hazardous waste	89.4
Other	485.7
Bulky waste	268.3
Waste from greenery	549.4

Furthermore, out of the 7 013 (excluded bulky waste) Mtons of waste produced by Polish households in 2013, the 37 000 tonnes of textiles and 1 000 tonnes of batteries collected (Głównego Urzędu Statystycznego - Central Statistical Office in Warsaw, 2014) were subtracted from the respective fractions.

The polymeric composition of plastic bottles was extrapolated from the Poznan's HSW found in Boer et al. (2010). Since no specific studies for Poland were found regarding the other packaging waste, the Italian data from Rigamonti et al. (2014) were used as a proxy. Table 17 shows the modelled polymeric composition of plastic in Poland.

Table 17: Polymeric plastic composition in Poland modelled in this paper

	PET %	HDPE %
Plastic bottles	68.18	31.82
Other PI packaging		100

The final composition was then normalized to 100%.

3.4.7 Greece

No official data were found for household waste, thus information on municipal waste was used. The main fractions for the municipal waste composition (Food waste 28%, Garden waste 13%, Wood 5%, Paper/Cardboard 20.4%, Textiles 1%, Glass 4.6%, Metals 4.2%, Plastics 13.4% and others 10.6%) were found in Gibbs et al. (2014). They are very similar to the one found in Minoglou & Komilis (2013) taken from the Governmental Gazette published in 2003. The partition of "paper" between paper (85%) and cardboard (15%) was based on Minoglou & Komilis (2013). An average of the plastic composition in the municipality of Kos, in the Communities of Kos, in Chania and in the Municipality of Naxos (Theodoseli and Karagiannidis, 2004) was made and the plastic fraction was divided in 52% soft plastic, 9% PVC, 9% PET and 30% non-specified. PVC and 50% of the non-specified plastic was added to the combustibles, while 50% of the non-specified plastic was assumed to be HDPE and added to the other plastic packaging. No information was found between the plastic bottles content in the waste, thus all the plastic packaging is included in the fraction other plastic packaging. The metals were split with 69% in ferrous materials and 31% non-ferrous (Theodoseli & Karagiannidis 2004 and Economopoulos 2010). The glass was divided in equal parts between clear, green and brown glass. The fraction called "others" was divided in 23% sanitary material, 2% Ash, 1% Batteries, 39% Combustibles and 35% Other-combustibles based on the information found in Theodoseli & Karagiannidis (2004) and EPEM – Environmental and Planning Engineering and Management S.A. (2014). The "fines" coincides with ashes.

The organic waste was divided in 68% Food waste and 32% Garden waste (Gibbs et al., 2014). The latter was subtracted from the data because excluded from the study.

To obtain the final composition, wood and batteries separately collected were subtracted from the original data since their treatment is not focus of the paper: in 2010, Greece produced 5 153 Mtonnes of household waste (excluded the fraction called in the data "discarded equipment") and, in average between 2010 and 2011 collected 6 845 tonnes of batteries and 26 000 tonnes of wood packaging (Anthouli et al., 2013).

Since no information was found regarding the polymer composition of the Plastic, the average composition between plastic bottles and other packaging in Italy was used as a proxy.

The final composition was then normalized to 100%.

3.5 Household sorting

This chapter describes the sources and the assumptions behind the household sorting efficiencies. Table 18 and Table 19 show the generic and the detailed composition of the household sorting efficiencies for each country. Afterwards is the comprehensive explanation for each country.

The main difficulty was encountered when the sorting efficiencies were calculated starting from the quantities source-sorted compared to the quantities generated in each country. In case the literature sources were different for the waste generated and for the source-sorted waste collected, additional assumptions were carried to correct the potential errors.

Generic assumptions have been taken for all the countries:

- In case household data are not available, municipal waste is assumed to have the same sorting efficiencies as household waste as in DK, FR and IT.
- Waste collected in civic amenities sites is not included. Unfortunately, it was not always clear when sorting efficiencies and material collected included the civic amenities. To avoid distortions, data were treated in the more coherent way possible.
- The composition of the collected material (e.g. division of plastic in PET, HDPE and soft plastic) is assumed to be the same as the generated fraction, if further information are not found. Per example the percentage of PET, HDPE and soft plastic in the plastic fraction are the same in both the generated and the source-sorted collected fraction. This assumption was valid in all the countries but FR and UK where a compositional analysis of the collected material was carried on.
- Only three types of collection are modelled based on Pressley et al. (2015): single-stream (all the recyclables together), dual stream (recyclables separated into a fibre and non-fibre stream) and pre-sorted (recyclables separated into a fibre stream, a glass stream and plastic plus metal stream).
- The composite material collection is neglected and mixed with the residues.
- All the source-sorted fractions are clean, thus the quality of the second material produced are not affected by impurities. In reality, impurities have a big impact on the quality of the recycling process.

Table 18: Detailed household sorting efficiencies

	DE [%]	DK [%]	FR [%]	UK [%]	IT [%]	PL [%]	EL [%]
Food waste	66.80	0	17.58	10.01	45.10	9.33	0
Office paper	78.73	69.50	47.99	63.57	59.08	13.87	13.46
Cardboard	78.73	69.50	37.17	51.32	59.08	13.87	13.46
Soft plastic	42.98	0	4.89	6.02	35.73	24.79	17.39
Plastic bottles	-	-	58.11	64.91	35.73	24.79	-
Other packaging PI	42.98	17.00	8.63	27.66	35.73	24.79	17.39
Clear glass	94.61	68.50	54.73	87.05	71.19	35.87	24.36
Green glass	94.61	68.50	75.52	95.54	71.19	35.87	24.36
Brown glass	94.61	68.50	75.52	91.85	71.19	35.87	24.36
Non-Fe cans	51.84	38.50	5.21	37.63	19.08	8.59	32.59
Ferrous cans	51.84	38.50	28.20	39.74	19.08	8.59	32.59

Table 19: Household sorting efficiencies for generic fractions

	DE [%]	DK [%]	FR [%]	UK [%]	IT [%]	PL [%]	EL [%]
Organic	66.80	0.00	17.58	10.01	45.10	9.33	0.00
Paper/Cardboard	78.73	69.50	44.52	60.86	59.08	13.87	13.46
Plastic	42.98	9.62	20.59	25.61	35.73	24.79	17.39
Metal	51.84	38.50	23.82	38.98	19.08	8.59	32.59
Glass	94.61	68.50	67.63	90.02	71.19	35.87	24.36
TOT	52.20	26.95	25.21	30.95	38.73	12.30	8.12

3.5.1 Germany

The Federal Statistical Office of Germany published in 2014 all the data concerning the waste in the country for the year 2012 (Table 20).

Table 20: Household waste collected in Germany in 2012 (Statistisches Bundesamt Wiesbaden, 2014). *The total value does not include bulky waste, the hazardous waste, other special waste, textiles and wood collected fractions

	* 1000 t
TOT*	34 226.30
Separately collected recyclables	
Glass	1 908.80
Paper and Cardboard	5 837.80
Metal	253.30
Plastic	126.10
Light packaging (composites)	2 570.00
Bio bin (= Kitchen waste)	4 358.50
park and garden	4 737.00
Mixed waste	13 212.80

Since the quantity of glass and of garden waste collected was higher than the quantity calculated in the composition in this model, an efficiency of collection equal to 95% and 90% was assumed, respectively.

The kerbside collection in Germany is usually structured as follows (Tampere Regional Solid Waste Management Ltd. et al., 2014):

- Blue bin for paper and cardboard
- Yellow bin for lightweight packaging (mainly metals and plastic)
- Brown or green bin for the biological waste
- Grey bin for household waste
- Waste glass is collected in a bring scheme and it is often colour separated in clear, green and brown glass

For this reason, the collection scheme of the German household waste is modelled as a pre-sorted scheme.

Comparing the values described in SI 3 with the quantity of waste collected, the household sorting efficiencies are calculated for Germany (Table 21)

Table 21: Household sorting efficiencies in Germany. The values are shown as percentages.

Food waste	Office paper	Cardboard	Soft plastic	Plastic bottles	Other packaging Plastic	Clear glass	Green glass	Brown glass	Non-Fe cans	Ferrous cans
66.80	78.73	78.73	42.98	-	42.98	94.61	94.61	94.61	51.84	51.84

3.5.2 Denmark

The sorting efficiencies in Denmark are based on a project carried by the Ministry of the Environment in 2013 in the municipality of Frederiksberg, where the sorting efficiencies were calculated with based on waste analysis and on the waste reported from the municipality (Table 22). Their average is assumed to be representative of all of Denmark. Even if it is known that the assumption is very strong, no other data were found in literature. It was not possible to use the national data published by the government because the metals from the bulky were added to the metal fraction and they it could not be disaggregated (Gibbs et al. 2014).

Table 22: Efficiencies of source-sorting collection in the municipality of Frederiksberg (Miljøministeriet, 2013)

	Efficiencies based on waste analysis	Efficiencies based on the waste reported from municipalities	Average modelled in this paper
	%	%	%
Plastic packaging	22	12	17.00
Glass packaging	68	69	68.50
Metal packaging	52	25	38.50
Cardboard packaging	45	58	51.50
Paper	64	75	69.50

Due to several typologies of collection present in Denmark, the Danish collection scheme is modelled only as pre-sorted scheme.

In Denmark, the majority of source-sorted plastic collection does not involve soft plastic, thus, in this model, 100% of the soft plastic is sent directly to incineration.

No source-sorted collection for food waste is modelled in Denmark.

3.5.3 France

The material collection of MSW in France in 2011 is shown in Table 23. Impurities are assumed to be included in the quantities even if it was not specified in the paper.

Table 23: Material collected in 2011 in France of the MSW (ADEME, 2011)

	TOT
	Mt
Source-sorted collection of glass	1886
Source-sorted collection of dry recyclables	3104
Source-sorted collection of bio-waste	1 256
Collection of residual waste	18783

The detailed compositional analysis of collected dry recyclables was conducted by the French Environment and Energy Management Agency in the same municipal waste characterization campaign utilised for the HSW composition (ADEME, 2010a). The calculated household sorting efficiencies are shown in Table 24.

Table 24: Household sorting efficiencies in France. The values are shown as percentages.

Food waste	Office paper	Cardboard	Soft plastic	Plastic bottles	Other packaging Plastic	Clear glass	Green glass	Brown glass	Non-Fe cans	Ferrous cans
17.58	47.99	37.17	4.89	58.11	8.63	54.73	75.52	75.52	5.21	28.2

Glass is rarely collected together with the other dry recyclables. 60% of the other recyclables (metal, paper, cardboard and plastic) is collected in a co-mingled bin, 21% considers a separated collection of paper, 5% divides fibrous and non-fibrous material and the rest corresponds to other types of collection (ADEME, 2011). In this model, 100% of glass is collected separately, 60% of the other recyclables in a co-mingled bin (dual-stream) and 40% dividing fibrous and non-fibrous material (Pre-sorted scheme).

Bio-waste includes both food and garden waste from households. In 2009, 43 Mt (18%) of food waste and 190Mt (82%) of food and garden waste were collected (ADEME, 2013). Since this paper does not include the treatment of garden waste, the 190Mt were split 83% as food and 17% as garden as in the household waste composition. The assumption is considered acceptable because the amount reported in this "bio-waste" includes only the kerbside collection. The garden waste collected in the civic amenities is not included in this number and it represents the great majority of the green waste treated in France (3 526 Mt in 2009).

The 81.10 Mt of collected composites material is sent to treatment together with the residual waste because composites recycling is not modelled in this paper.

3.5.4 United Kingdom

Table 25 shows the collected fractions in England in 2013 (DEFRA, 2014a). Since the quantities reported do not include the rejects from MRFs they have to be calculated.

Environment Food and Rural Affairs Committee - Parliament UK (2014) shows that out of 10 457 Mt of recyclables collected in England, 226 Mt of contaminants were rejected out equal to 2.16% of the total amount. For this reason, all the fractions collected were raised of 2.16%.

Table 25: Source-sorted collection of dry recyclables quantities excluding (DEFRA, 2014a) and including the rejects from the sorting facilities in Mt.

	Fractions excluded rejects [Mt]	Fractions including rejects [Mt]
Glass	1 102	1 126
Paper and cardboard	2 393	2 445
Metals	219	224
Plastic	389	398

Waste collected from Civic amenities, Bulky and WEEE are not included in the sorting efficiencies modelled. The detailed composition of each collected quantity are taken from the compositional analysis conducted in England in 2010/2011 as explained in SI 3.4.4.

It has to be noted that following this methodology the green glass recycled were higher than the green glass generated in England, thus, for this particular fraction, a collection rate equal to 95% was assumed.

Regarding the organic waste collected fractions, it is not easy to split it in food and garden because they are often collected together (M-E-L Research, 2008) and in 2013/2014, only 33% of local authorities in UK collected food waste (WRAP, 2014a). But the result calculated (10.01%) was confirmed by the Committee publication on waste management in England published in 2014 where the food collection was set equal to 10%. (Environment Food and Rural Affairs Committee - Parliament UK, 2014).

The lower collection rate of soft plastic and packaging respect the plastic bottles is confirmed in (RECOUP, 2014): 96% of the UK Local Authorities collects plastic bottles, 60% pots, tubs and trays and only 16 % plastic films. In the same paper, a house-sorting rate of 58% for plastic bottles, 19% for pot, tubes and trays and 37% for rigid plastic packaging was given, meaning that the calculated numbers used in this paper are credible.

Comparing the values described in SI 3 with the quantity of waste collected, the household sorting efficiencies are calculated for UK (Table 26).

Table 26: Household sorting efficiencies in UK. The values are shown as percentages.

Food waste	Office paper	Cardboard	Soft plastic	Plastic bottles	Other packaging Plastic	Clear glass	Green glass	Brown glass	Non-Fe cans	Fe cans
10.01	63.67	51.40	6.03	65.01	27.70	87.19	95.00	91.99	37.69	39.80

Table 27 shows the collection scheme in UK reported by WRAP in 2014. In this paper, 52% of the collection is modelled as one stream, 17% as dual-stream and 31% as pre-sorted.

Table 27: Operating household schemes of local authorities for dry recycling collection in 2013/14 (WRAP, 2014b)

Collection scheme	Households on scheme	%	Description
Co-mingled	14707386	50	All materials are collected together
Multi-stream	6733708	23	Materials are sorted by the household or on collection at the kerbside into multiple material streams. The material streams may include a selected mix of some materials, typically cans and plastics.
Single material	121185	0.41	Only one material is collected
Double stream	7950286	27	Materials are collected as two material streams, typically fibres and containers, at least one of which requires sorting at a MRF

3.5.5 Italy

The National Report on Municipal Waste published the quantity of collected material in 2013 shown in Table 28. The organic waste is composed of 65% food waste and 35% garden waste (ISPRA, 2014). Impurities are assumed to be included in the quantities even if it was not specified in the paper. Garden waste is not considered. The detailed composition of the collected fractions is assumed to be the same as the household waste because no more detailed data were found.

Table 28: Collected sorted material from municipal waste (ISPRA, 2014). **the fraction includes composites material that in this paper is added to the residues

Collected material	
* 1000 t	
Organic	5223.55
Paper/Cardboard**	3051.99
Glass	1602.15
Plastic	944.99
Metal	240.51

Comparing the values described in SI 3 with the quantity of waste collected, the household sorting efficiencies are calculated for Italy (Table 29).

Table 29: Household sorting efficiencies in Italy. The values are shown as percentages.

Food waste	Office paper	Cardboard	Soft plastic	Plastic bottles	Other packaging Plastic	Clear glass	Green glass	Brown glass	Non-Fe cans	Ferrous cans
45.10	59.08	59.08	35.73	35.73	35.73	71.19	71.19	71.19	19.08	19.08

The collection scheme in Italy is described in Table 30 and is calculated utilizing the co-mingled composition for 2013 (ISPRA, 2014) and the types of co-mingled collection reported for 2011 in Ancitel Energia e Ambiente S.r.l. (2012). Since no more recent data were found, the co-mingled schemes were assumed the same in 2011 and in 2013.

Table 30: Collection schemes for each fraction relative to the total fractions produced

	One stream	Two streams	Pre-sorted	TOT
	%	%	%	%
Paper/cardboard	2.49	8.71	34.01	45.21
Plastic	2.57	7.53	25.63	35.73
Metals	0.89	3.23	14.97	19.08
Glass	1.60	14.18	55.41	71.19

3.5.6 Poland

The quantities collected in Poland in 2013 from household are shown in Table 31. The quantities derives from the data collected in Głównego Urzędu Statystycznego - Central Statistical Office in Warsaw (2014) excluding bulky,

textiles and hazardous waste. The total does not include bulky, textiles and hazardous waste. The detailed composition of each collected fraction is assumed to be the same as in the generated household waste.

Table 31: Tot waste and fractions collected from household in Poland in 2013

Fractions collected (2013)	Mt
Mixed residuals	6110
Paper and cardboard	132
Glass	273
Plastics	185
Metals	15
Biodegradable	227
TOT	6975

Comparing the values described in SI 3.4 with the quantity of waste collected, the household sorting efficiencies are calculated for Poland (Table 32).

Table 32: Household sorting efficiencies in Poland. The values are shown as percentages.

Food waste	Office paper	Cardboard	Soft plastic	Plastic bottles	Other packaging Plastic	Clear glass	Green glass	Brown glass	Non-Fe cans	Ferrous cans
9.33	13.87	13.87	24.79	24.79	24.79	35.87	35.87	35.87	8.59	8.59

It was not possible to find the method of collection for Poland, so the city of Warsaw was used as an example for the whole country: each household has available three bins, one for glass and one for the other dry recyclables and one for the residuals (Miasto Stołeczne Warszawa - The city of Warsaw, n.d.). In addition, one bin for organic waste is used in the cities where organic is collected.

3.5.7 Greece

The quantities of packaging waste collected from households are shown in Table 33. The quantities taken from Gibbs et al. (2014) exclude the reject losses from the sorting processes that are estimated to be around 34% in the same paper. Since, the values collected for the other countries included the losses from the MRFs, the values found have been increased of 34%.

Table 33: Packaging waste collected in Greece (Gibbs et al. 2014)

	Excluding reject losses [Mt]	Including reject losses [Mt]
Cardboard/paper	105.70	141.63
Glass	43.15	57.82
Metal	52.70	70.62
Plastic	68.53	91.83
TOT	270.08	361.91

Ezeah & Byrne (2014) claimed that recyclables were equal to 17-18 % of the total waste collected. Even if it was no possible to find such high values with the assumptions made, it has to be noted that the actual recycling could be higher.

No source-sorted collection of food waste was modelled in Greece based on the data provided in Bakas and Milios (2013) where only 1% of the total MSW was collected in 2013 as organic waste.

Comparing the values described in SI 3.4 with the quantity of waste collected, the household sorting efficiencies were calculated for Greece (Table 34)

Table 34: Household sorting efficiencies in Greece. The values are shown as percentages.

Food waste	Office paper	Cardboard	Soft plastic	Plastic bottles	Other packaging Plastic	Clear glass	Green glass	Brown glass	Non-Fe cans	Ferrous cans
-	13.46	13.46	17.39	-	17.39	24.36	24.36	24.36	32.59	32.59

Regarding the collection scheme, only 27% of the paper is collected separately, and the rest of paper, glass, metal and plastic are collected as co-mingled in one bin (Anthouli 2013 and Gibbs et al. 2014).

3.6 Collection

Collection is defined in terms of fuel consumption per tonne of wet waste from the first stop on the collection route to the final stop on the collection route (Larsen et al., 2009). All the collection trucks are assumed to be EURO3 and to be diesel-fueled. The fuel is measured from the garage to the start of the collection route, driving during the waste collection and from the unloading point to the garage. Because of the lack of data, few simplifications are applied during the modelling: residual and food collection is modelled as the fuel consumption of the residual waste collection in the city centre, while dry recyclables as glass collection in the city centre. The fuel consumptions are based on values from Denmark collected in Larsen et al. (2009) and shown in Table 35.

Table 35: Fuel consumption for residual and food waste and dry recyclable collection (Larsen et al., 2009)

Fraction	Fuel consumption
Residual waste	3.07 E-03 l/ kg _{ww}
Food waste	3.07 E-03 l/kg _{ww}
Dry recyclables	4.9 E-03 l/kg _{ww}

3.7 Material recovery facilities

All recyclables are modelled as collected in a material recovery facility (MRF). Material recovery facilities (MRF) are characterized by 4 parameters: sorting efficiencies, diesel, electricity and wire consumptions. The consumption of electricity and materials depends on the collection schemes based on the data collected by Pressley et al. (2015). In this paper, the sorting efficiencies of the MRF are assumed to be the same in all Europe, independently of the country and the type of collection. This assumption is due to two main reasons: there are different ways of reporting percentages of residues leaving the MRFs, and the efficiencies are subjected to a great variability because they are influenced by the type of collection (on street banks system vs. kerbside system and mono-material collection vs. multi-material collection), the level of collection and by the civil behaviour of citizens" (Lucia Rigamonti et al., 2009). The efficiencies used in the baseline are an average of values found in literature (ADEME and Eco-Emballages et Ecofolio, 2014; L. Rigamonti et al., 2009; Lucia Rigamonti et al., 2009) and are presented in Table 36. The efficiencies found in Pressley et al. (2015) were considered too high compared to the others, thus, they were not considered.

All residues from MRFs are modelled to be disposed in an mineral landfill. Even though in the reality some countries send plastic and paper residues to WtE plants, the difference of impacts due to the two types of disposal is negligible.

Table 36: Average, maximum and minimum sorting efficiencies (ADEME and Eco-Emballages et Ecofolio, 2014; L. Rigamonti et al., 2009; Lucia Rigamonti et al., 2009)

Fraction	Average	Max	Min
	%	%	%
Paper/Cardboard	92.42	96.75	85.50
Glass	92.05	94	90.1
Steel	88.33	95.00	80.00
Al	90	95	80
PET	78	78	78
PE	74.5	74.5	74.5
Soft plastic	60	60	60

The residues from the MRF are all sent to a mineral landfill that is described in SI 3.8.3.

Diesel consumption is equal to 0.7 L/t input and it does not depend on the type of MRF (Pressley et al., 2015). The diesel consumption is modelled with the process "Forklift, combustion 1L of diesel, 2003/2011" (EASTECH database). Both the electricity and the wire consumption were calculated as a weighted average of the different collection systems in each countries (single-stream, dual-streams or pre-sorted) defined in Pressley's data. The wire mass was modelled with two processes from the ecoinvent database: for each kg of steel wire utilised, 1 kg of "steel production, converter, unalloyed, RER" and 1 kg of "wire drawing, steel, RER" were added. Table 37 shows the electricity, diesel and wire mass consumption for each country.

Table 37: Electricity, diesel and wire mass consumption for each country based on Pressley et al. (2015)

	Electricity MWh/kg input	Diesel L/t input	Wire mass kg/kg input
DE	4.83E-03	0.7	7.00E-04
DK	5.29E-03	0.7	7.00E-04
FR	8.08E-03	0.7	6.40E-04
UK	7.28E-03	0.7	6.31E-04
IT	6.31E-03	0.7	6.76E-04
PL	8.33E-03	0.7	6.00E-04
EL	7.76E-03	0.7	6.00E-04

3.8 Waste Treatment

Combining several data sources, the fate of residual waste and of source-sorted food waste was calculated (Table 38). In case information on HSW was not founded, MSW data were used (as in DE, EL, FR, IT and PL). Following is the description for each country. Due to the information available, only 3 types of treatment were modelled for residual waste, landfill, waste-to-energy (WtE) and mechanical biological treatment (MBT). Landfilling is still the main treatment of residual waste in Greece, Italy, Poland and UK. Moreover, only two types of treatment are modelled for food waste: vessel composting and anaerobic digestion (AD). AD is considered only in Germany and Italy because it still treats too little quantity in the other countries. The systems in Denmark and Greece do not include source-sorted food waste because the quantities are negligible. Following the detailed data collection for each country

Table 38: Fate of residual waste and source-sorted organic waste.

		DE	DK	FR	UK	IT	PL	EL
Residues	Landfill	-	-	36 %	56 %	49 %	85 %	100 %
	Incineration	82 %	100 %	64 %	44 %	31 %	-	-
	MBT	18 %	-	-	-	20 %	15 %	-
Bio-waste	AD	41 %	-	-	-	12 %	-	-
	Composting	59 %	-	100 %	100 %	88 %	100 %	-

Germany

German law prohibits landfilling of non-treated waste, thus residual waste is sent either to incineration or to MBT. Table 39 shows the destination of German residual waste. The percentage sent to landfilling is neglected because it is probably constituted only of hazardous waste.

Table 39: Residual waste treatment in Germany (Gibbs et al., 2014)

	* 1000 t	%
To incineration	15 296	81.33
To MBT	3 285	17.47
To landfill	226	1.20

Table 40 shows the destination of the bio-waste in Germany. Unfortunately, data concerns both food and garden waste. 59% of bio-waste is directed to composting plants (for mixed and only garden) and 41% to anaerobic digester. These are the percentages modelled in the system for German food waste.

Table 40: Input of source-sorted organic waste in each plant (Statistisches Bundesamt Wiesbaden, 2014)

	* 1000 t	%	
Bio-composting for mixed bio waste	4 094.3	31.5%	58.5%
Green waste composting plants	3519.3	27.1%	
Anaerobic digestion plants	5 394.5	41.5%	41.5%

TOT	13 008.1	100%
-----	----------	------

Denmark

Table 41 shows the destination of the total household waste in Denmark (Miljøministeriet, 2014). In this model, 100% of the residual waste is sent to incineration with energy recovery. No source-sorted food collection is considered because the actual quantity collected is negligible.

Table 41: Household waste treatment in Denmark in 2012 (Miljøministeriet, 2014)

	%
Recycling	43 %
Incineration	52 %
Landfill	4 %
Temporary storage	1 %

France

Table 42 shows the treatment for the residual waste collected in France. In this model, only landfill and incineration with energy recovery are considered that are modelled as 36.35 and 63.65 %, respectively. AD is neglected in France because only 410 000 tonnes (ADEME, 2013) of food waste were sent to anaerobic digestion in 2013 (about 4% of the food fraction).

Table 42: Fate of the residual municipal waste in France in 2011 (ADEME, 2011)

	Tot	Recycling	Incineration with energy recovery	Incineration without energy recovery	Landfill	Organic treatment
1 000 t	18 783	187	11 026	394	6 292	884
%	100	1.00	58.70	2.10	33.50	4.71

United Kingdom

Table 43 shows the treatment of household waste. MBT, incineration without energy recovery and AD. In the model, 55.88 % of the residual waste is modelled as landfilled and 44.12 % as incinerated with energy recovery.

Table 43: Regional breakdown - Management of Local Authority collected waste in England, 2013/14 (Defra, 2014).
*EfW means Energy from Waste ** Others include MBT and AD

Method	Landfill	Incineration with EfW*	Incineration without EfW*	Recycled/composted	Other**	Total
1 000 t	7 933	6 204	41	10 931	537	25 645
% of the total generated waste	30.9%	24.2%	0.2%	42.6%	2.1%	100 %
% of the residual waste	53.9%	42.16%	0.28%	-	3.65%	100%

Italy

Table 44 resumes the total municipal waste treated in a WTE plant, MBT plant and landfill (Gibbs et al., 2014). Excluding WEEE from the calculation, 49%, 31% and 20% of the residuals are sent to landfilling, MBT and WTE, respectively.

Regarding source-sorted food waste, in 2013 12% was treated in AD plants (usually followed by composting) and 88% in composting plants (Fondazione Sviluppo Sostenibile, 2014).

Table 44: Quantity of waste incinerated (Gibbs et al., 2014)

	Total municipal waste [t]	Total municipal waste without WEEE and "others" [t]
WTE	5 290 454	4 884 012
MBT	9 234 589	7 886 339
Landfill	13 205 749	12 198 794

Poland

Poland still landfills the majority of municipal waste (Fischer, 2013). Based on the data collected by Gibbs et al. (2014) shown in Table 45, only 13 % (about 15% of the residual waste) of the generated waste is sent to MBT plants that are mainly of the type of bio-stabilization with outputs sent to landfill. Incineration is not considered because only 0.5% of the generated waste was treated in WTE plants in 2012 (Central Statistical Office, 2013).

Table 45: MSW generated, recycled and sent to MBT in Poland in 2011 (Gibbs et al., 2014)

	1 000 t
MSW generated	12 528
MSW recycled	1 328
MSW treated in MBT	1 434

Regarding the treatment of source-sorted food waste, no relevant evidence of anaerobic digestion in the country was found in literature, thus, all the food waste is modelled as composted.

It has to be mentioned that there was some confusion about the quantity sent to dirty MRFs. Each year, the Polish Central Statistical Office publishes a report on ecological subjects. Up to 2013, it published the recyclables sorted from mixed waste (Głównego Urzędu Statystycznego - Central Statistical Office in Warsaw, 2013) , while they were not mentioned in the report published in 2014 (Głównego Urzędu Statystycznego - Central Statistical Office in Warsaw, 2014). For this reason, dirty MRFs are not included.

Greece

The majority of waste in Greece is landfilled: in 2010, 80% of the waste generated was landfilled (Bakas and Milios, 2013) and in 2013 Greece had in no incineration capacity, nor any source-sorting of bio-waste (Anthouli et al., 2013). Few MBT facilities are in use, but several papers highlighted the difficulty to report the actual quantity of waste treated in them. At the same time Gibbs et al. (2014) reported only 260 Mt as input of MBT plants on 4 612 Mt of waste produced. For these reasons, 100% of the residual waste was sent to landfill in this paper.

3.8.1 Recycling

Generic European recycling processes are modelled for all the countries for two main reasons. First of all, nowadays the destination of dry recyclables depends on the market prize and it is very hard to follow the recyclables in their paths through countries. Furthermore, the technological level of recycling is assumed to be similar in the European countries.

It has to be noted that different studies have highlighted that modelling recycling processes is affected by great uncertainty, because the impacts strongly depend on the assumptions (Merrild et al. 2008 and Brogaard et al. 2014).

Recycling processes are defined by a substitution ratio that describes how much primary material is avoided by recycling. It is calculated as the product between the recovery efficiency and the market ratio (Table 46), for example 1 kg of Aluminum entering in the recycling plant substitutes only 0.93 kg of primary Al. The recovery efficiency (or reprocessing efficiency) refers to the recovery activity in itself (e.g. efficiency of furnace), while the market ratio refers to the quality of the secondary material produced (Rigamonti et al., 2010). The secondary material always substituted primary material. Two exceptions were however introduced: 1) For unalloyed steel the employed ecoinvent database (ecoinvent, 2016) contains no dataset representing steel production from a mix of steel scrap and virgin mineral ore and we had to use a dataset for steel production from virgin mineral ore in the assessment of steel recovery, and 2) for assessing the recovery of paper we used a dataset for newsprint

production from virgin pulp, because the majority of newsprint used in Europe is produced from recycled paper of which recovered newsprint from households makes up a significant part and it has no meaning to substitute recovered paper with recovered paper. However, the results of this choice was assessed in a scenario analysis assuming that recycled paper from households substitutes production of newsprint based on recovered paper

Table 46: Recovery efficiencies (A) and market ratio (B) for the recycling processes. The substitution ratio is equal to A*B.

material	A (Rigamonti, 2007)	B (Rigamonti et al., 2010)	A*B	Substituted material (ecoinvent)
Paper	1.00	0.83	0.83	"Paper production, newsprint, virgin, RER" (ecoinvent)
Cardboard	1.00*	0.83*	0.83	"Corrugated box production, RER" (ecoinvent)
PET	0.755	0.81	0.61	"polyethylene terephthalate (PET) production, granulate, amorphous, RER" (ecoinvent)
HDPE	0.90	0.81	0.73	"polyethylene production, high density, granulate (PE-HD), RER" (ecoinvent)
Soft plastic	0.6	1	0.6	"Particle board production, for outdoor use, RER" -(ecoinvent)
Glass	1.00	1	1.00	"Packaging glass production, green, RER w/o CH+DE" (ecoinvent)
Aluminium	0.93	1	0.93	"Aluminium, Al (Primary), World average" (International Aluminium Institute, 2007)
Steel	0.84	1	0.84	"steel production, converter, unalloyed, RER" (ecoinvent)

* The coefficients for cardboard are assumed to be the same as paper.

The energy consumption for PET, HDPE, soft plastic, glass, aluminium and steel recycling is based on Rigamonti (2007). Since EASETECH calculates the external processes (emissions, material or energy utilised) per kg entering into the process, and Rigamonti calculated them per kg output, the following formula has been used:

$$\text{Emissions } kg_{input} = \text{Emissions } kg_{output} * B \text{ where } B \text{ is the recovery efficiency}$$

The external processes modelled are shown in Table 47. The emissions for secondary glass, aluminium and steel can be found in Rigamonti (2007). Since it is difficult to quantify the emissions produced by the secondary production of PET, HDPE and particle board, they were neglected (Rigamonti 2007). Few assumptions were made while modelling them in EASETECH:

- The emitted substances not present in the Software were excluded: halogenated hydrocarbon, chlorides, fluorides and VOC (Volatile Organic Compounds) for Aluminium; TOC (Total Organic Carbon), chlorobenzene and hexachlorobenzene for steel.
- When the particle-size distribution was not specified, all the PM were assumed to be between 2.5 and 10 μm like in the case of aluminium and steel.
- Only the specified metals emitted were modelled for glass.

Finally, Paper recycling process is based on EASTECH database and cardboard recycling on ecoinvent datasets (Table 48). Cardboard recycling is modelled with the process "treatment of recovered paper to lineboard, testliner" from ecoinvent datasets, normalized with 1.0417 output. From the European recycling of paper and cardboard, newspaper and case material are the most common secondary products, respectively (CEPI - Confederation of European Paper Industries, 2013). Composite materials recycling is excluded due to the low amount in the waste and to the potential high uncertainty of its modelling.

Table 47: External processes added in the recycling processes excluding paper and cardboard

Name	Amount	Unit
PET		
Mix electricity ENTSO	2.58E-01*0.75	kWh / kg _{ww input}
Mix heat EU	2.5*0.75	MJ / kg _{ww input}
PET production, granulate, amorphous	-0.61	kg / kg _{ww input}
HDPE		
Mix electricity ENTSO	3.79E-01*0.9	kWh / kg _{ww input}
Mix heat EU	6.5E-01*0.9	MJ / kg _{ww input}
Polyethylene high density granulate (PE-HD)	-0.73	kg / kg _{ww input}
Soft plastic		
Mix electricity ENTSO	3.81E-01*0.6	kWh / kg _{ww input}
Mix heat EU	6.5E-01*0.6	MJ / kg _{ww input}
Particle board production, for outdoor use	-0.6	kg / kg _{ww input}
Glass		
Mix electricity ENTSO	1.84E-02	kWh / kg _{ww input}
Mix heat EU	5.2	MJ / kg _{ww input}
Packaging glass production, green	-1.1	kg/kg _{ww input}
Packaging glass production, green	0.19	kg/kg _{ww input}
Aluminium		
Mix electricity ENTSO	7.9E-02*0.93	kWh / kg _{ww input}
Mix heat EU	4.885*0.93	MJ / kg _{ww input}
Aluminium, Al (Primary), World average, 2005	-0.93	kg / kg _{ww input}
Steel		
Mix electricity ENTSO	6E-01*0.84	kWh / kg _{ww input}
Steel production, converter, low-alloyed	-0.84	kg / kg _{ww input}

Table 48: Paper recycling process from EASETECH database.

EXTERNAL PROCESSES			
Name		Amount	Unit
Paper production, newsprint, virgin		-0.83	kg / kg _{ww input}
Process water, RER, ELCD, 2005 - corrected		21	kg / kg _{ww input}
Natural gas, EU-27, ELCD, 2002 - corrected		0.00011	kg / kg _{ww input}
Diesel, EU-15, ELCD, 2003 - corrected v2		0.003	kg / kg _{ww input}
Heavy fuel oil, EU-15, ELCD, 2003 - corrected		0.024	kg / kg _{ww input}
Spruce wood, DE, ELCD, 2005 - corrected		0.161	kg / kg _{ww input}
CTMP Pulp incl. Forestry, Sweden, 2001		-0.075	kg / kg _{ww input}
Sulphate Pulp incl. Forestry, Sweden, 2001		0.0089	kg / kg _{ww input}
Mix electricity ENTSO		0.42	kWh / kg _{ww input}
EMISSIONS			
Name	Compartment	Amount	Unit
Sulfur dioxide	air	0.00048	kg / kg _{ww input}
Nitrogen oxides	air	0.00064	kg / kg _{ww input}
Carbon dioxide, fossil	air	0.4	kg / kg _{ww input}
Water	Water, surface water	26.4	kg / kg _{ww input}
COD, Chemical Oxygen Demand	Water, surface water	0.0027	kg / kg _{ww input}

The assumptions made to model the recycling processes of each material are explained and justified as following:

- GLASS. Three different coloured glass fromecoinvent are modelled as substituted material for 1t of glass as input: "packaging glass production, brown"; "packaging glass production, green" and "packaging glass production, white". The normalized results do not show any difference, thus, green glass is used in the model.
- ALUMINIUM. Two different processes are modelled for 1t of Al cans input: one from Rigamonti, (2007) and one from EASETECH database. No differences are noted, thus, the recycling process from Rigamonti is used.

- STEEL. Two different substituted materials from ecoinvent are tried for 1t of Aluminium cans as input "steel production, converter, unalloyed" and "steel production, converter, low-alloyed" No relevant differences were noted, thus the low alloyed steel is used as primary avoided production.
- CARDBOARD. Three different substituted materials from ecoinvent are tested for 1t of cardboard input: "Core board production", "Corrugated board box production" and "lineboard production, kraftliner". "Corrugated box production" is used for the baseline. Important differences based on the choice of these materials were found, but due to the low importance of cardboard recycling in the overall results, there is no need to carry a sensitivity analysis.
- PAPER: Different substituted materials from ecoinvent database are tested in the process for 1t of paper input: "Graphic paper production, 100% recycled RER", "kraft paper production, unbleached RER", "paper production, newsprint, virgin RER" and "paper production, newsprint, recycled RER". "paper production, newsprint, virgin" is used in the baseline. Due to the differences noted between substituting virgin and recycled newsprint, a sensitivity analysis is carried out.
- PET/HDPE. Three different recycling processes are modelled for both PET and HDPE: the publications used are Rigamonti (2007), Rigamonti et al. (2014) and Franklin Associates (2011). Furthermore, two substituted materials from ecoinvent were utilized for PET recycling: "PET granulate amorphous" and "PET granulate bottles" from ecoinvent. In both the cases, no significant difference in the normalised impacts was noted, the process from Rigamonti (2007) and "PET granulate amorphous" are chosen.
- SOFT PLASTIC. The soft plastic need to be separated from the other plastic, to avoid problems in the recycling. In this paper, the recycling modelled from Rigamonti (2007) is used. Due to the lack of information regarding the composition of the soft plastic in the different countries, it is assumed that 1kg of soft plastic is equal to 1 kg of the mix used in Rigamonti's paper. Different substituted products from ecoinvent are tested for 1t of soft plastic input (Table 49). The density of the material tried is set to 540 kg/m³. Since soft plastic recycling does not show significant impacts in any category, "Particle board production, for outdoor use" is used in the baseline without running a sensitivity analysis.

Table 49: Secondary products imported from ecoinvent tested in EASETECH for the recycling of soft plastic

Material name
Particle board production, for outdoor use
Sawnwood production, hardwood, air dried, planed
Sawnwood production, hardwood, kiln dried, planed
Sawnwood production, hardwood, raw, air dried
Sawnwood production, hardwood, raw, kiln dried
Sawnwood production, softwood, air dried, planed
Sawnwood production, softwood, kiln dried, planed
Sawnwood production, softwood, raw, air dried
Sawnwood production, softwood, raw, kiln dried
Fibreboard production, hard

3.8.2 Landfill for residual household waste

Landfills for residual household waste are modelled according to Olesen and Damgaard (2014), where several modules are designed collecting data from scientific articles and validated through the judgment of experts. The scheme of the model is displayed in Figure 9. The time horizon of the inventory has been set to a default of 100 years. A screenshot of how the model in EASETECH is shown in Figure 10. All the countries are assumed to have "average landfills". Transfer coefficients are used to trace pollutants in the leachate treatment.

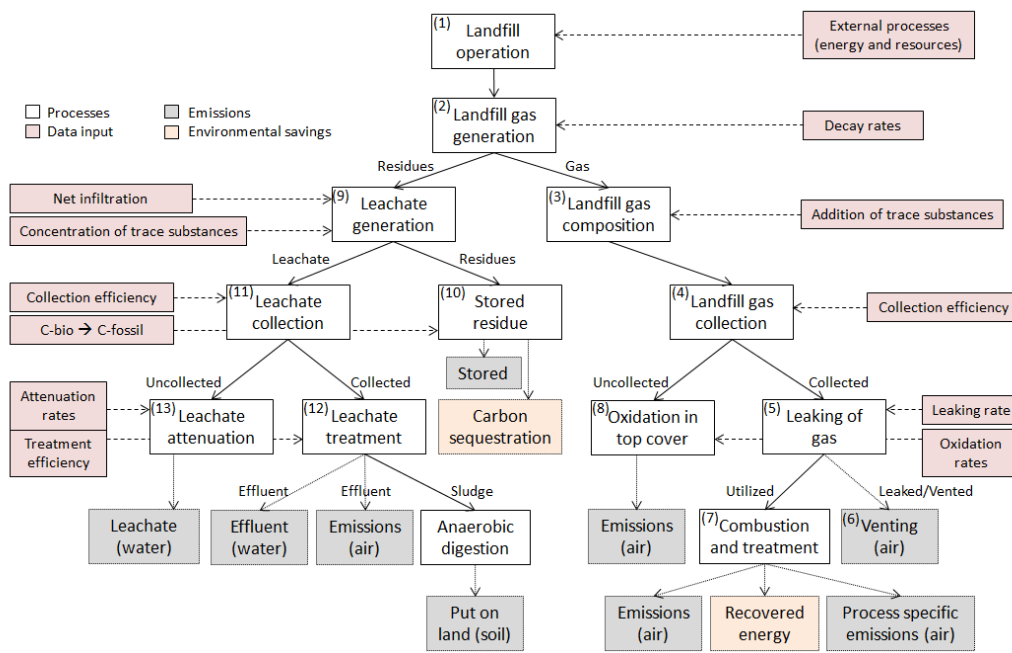

Figure 9: Scheme of the landfilling model in EASETECH

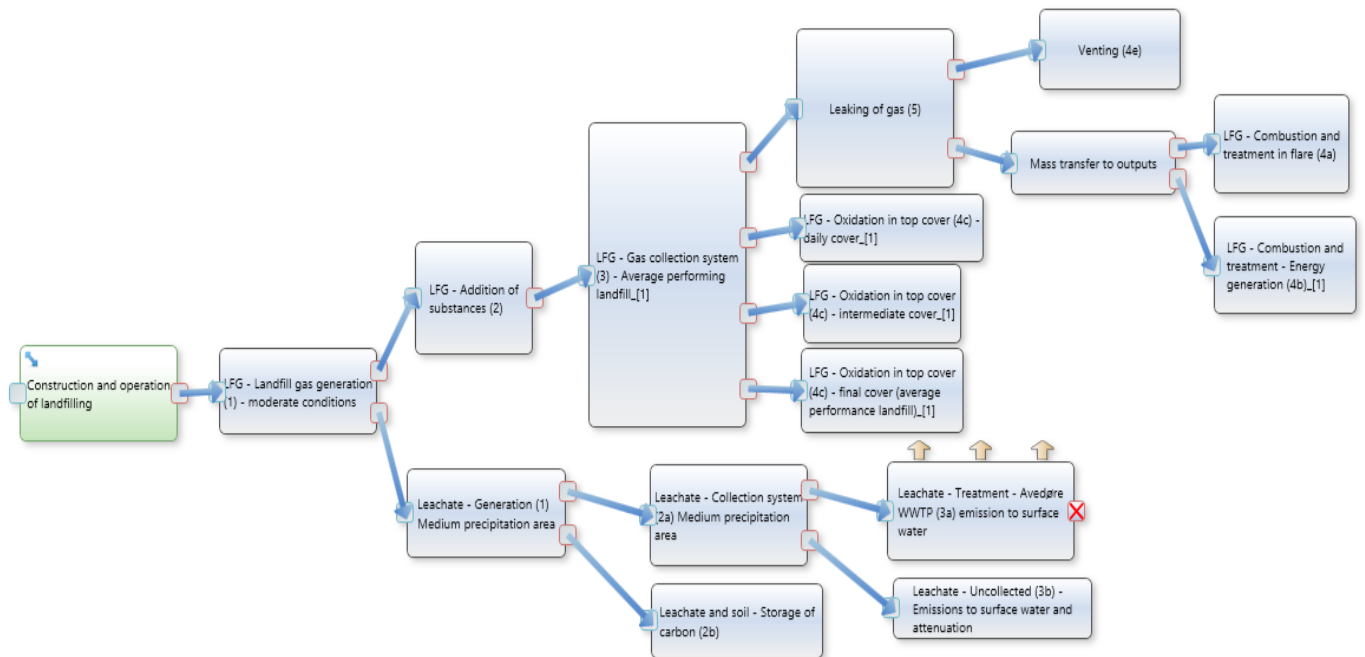

Figure 10: Screen shot from a landfill module in EASETECH

The paper was used with the following assumptions:

- All the landfills are considered “average performing”
- Three types of covers (daily, intermediate and final) are modelled for the oxidation in the top covers.

- All the countries have an average precipitation less than 1 000 mm/y. In theory UK has an average precipitation above 1 000 mm/y, but since England has 84% of the overall UK population (Office for National Statistics, 2014), the English precipitation, is considered instead. (Table 50).
- Table 51 shows the average gas collection and gas utilization rate for the first 55 years derive from the data resumed in Table 52 and from the expert knowledge on landfills in Europe. It has to be noted that the gas collection rate is a simplified model of what will actually happen in nature. It is set to an averaged constant value for the first 55 years and to zero after it.
- The leaking of gas from gas collection is set as zero and the venting is not modelled.
- All the collected leakage is sent to a wastewater treatment plant.

Table 50: Average precipitation and average yearly temperature in the countries where a percentage of the residual waste goes to landfill. * The English temperature is based on DEFRA (2014a)

Country	Average precipitation 2010-2014 [mm/year] (The World Bank, 2014)	Average yearly Temperature [°C] (The World Bank, 2011)
DE	700 – medium precipitation	8.4 (low T)
DK	703 – medium precipitation	7.5 (low T)
FR	867 – medium precipitation	10.7 (high T)
UK	1,220 – high precipitation	8.4 (low T)
England	Below 1 000 *	
IT	832 – medium precipitation	13.4 (high T)
PL	600 – medium precipitation	7.8 (low T)
EL	652 – medium precipitation	15.4 (high T)

Table 51: Gas collection and gas utilization rate assumed for the first 55 years.

Country	Gas collection [%]	Flaring [% of the collected gas]	Gas utilisation [% of the collected gas]
FR	70	20	80
UK	75	30	70
IT	60	50	50
PL	50	70	30
GR	30	70	30

Table 52: Information utilised on the landfill gas collection and valorisation in Europe

Country	Information found	Reference
FR	- In 2010, 33% of the landfills were provided of gas collection and valorisation and 61% of the total landfilled waste went to landfills with valorisation of the biogas.	(ADEME, 2010b)
UK	- In 2003, 63% of the landfill gas generated was flared or utilised, and it is forecasted to rise to 72% by 2005.	(Land Quality Management, 2003)
PL	- 363 landfills out of 431 (84%) have gas collection, but in 199 (55%) gas escapes to the atmosphere. - 70% of the landfills of which gas collected is neutralised by flaring and 30% by energy utilisation.	(Głównego Urzędu Statystycznego - Central Statistical Office in Warsaw, 2014)
EL	- In 2010, out of the 41 municipal waste landfill sites in operation, 16 sites collected gas using an active pump system, while 9 collected gas using a passive pump system. 4 landfill sites burnt the gas they collect, and only 2 landfill sites, one in Athens and one in Thessaloniki, used the gas for energy production.	(EUROCONSULTANTS and EPTA, 2010)

Regarding the type of energy produced from the landfill (electricity or heat), data for Germany, France and UK were extrapolated from the summary of country reports from members of IEA Bioenergy Task 37 published by the International Energy Agency in 2014 (Table 53). In Italy, Poland and Greece, 87% of the energy produced is modelled as utilized as electricity and 23% as heat (average of French and German data). Polish data were

supported by the national assessment of landfills in the country, where 80% of the landfills produced electricity and 20% heat (Głównego Urzędu Statystycznego - Central Statistical Office in Warsaw, 2014).

The energy recovery efficiency was based on Olesen and Damgaard (2014) shown in Table 54. It was assumed that no CHP landfill were on site and that either the landfill produces only electricity or only heat. By multiplying the percentage of the biogas utilization and the energy recovery efficiency for electricity and heat generation, the electricity and heat credited in each country was calculated (Table 55).

Table 53: Landfill biogas utilisation in Germany, France and UK (International Energy Agency Bioenergy, 2015)

	Electricity [GWh/year]	Heat [GWh/year]
Germany	540	90
	86%	14%
France	858	296
	74%	26%
UK	5169	
	100%	

Table 54: Energy recovery efficiency [%] for different technologies (Olesen and Damgaard, 2014).

Name	Vent	Flare	CHP	Electricity generation	Heat production
District heating	0	0	60 %	0	77 %
Electricity production	0	0	25 %	37%	

Table 55: Credited electricity and heat modelled in the paper

	FR	UK	IT	PL	EL
Percentage of electricity credited	28%	37%	32%	32%	32%
Percentage of heat credited	20%		10%	10%	10%

3.8.3 Landfill for inert waste

The modelling of the mineral landfill was based on the bottom ash landfill described in Møller et al. (2013). Figure 11 shows the modelling of the mineral landfill in EASETECH. The capital goods for the mineral landfill were assumed to be the same as the normal landfill because no more specific data were found.

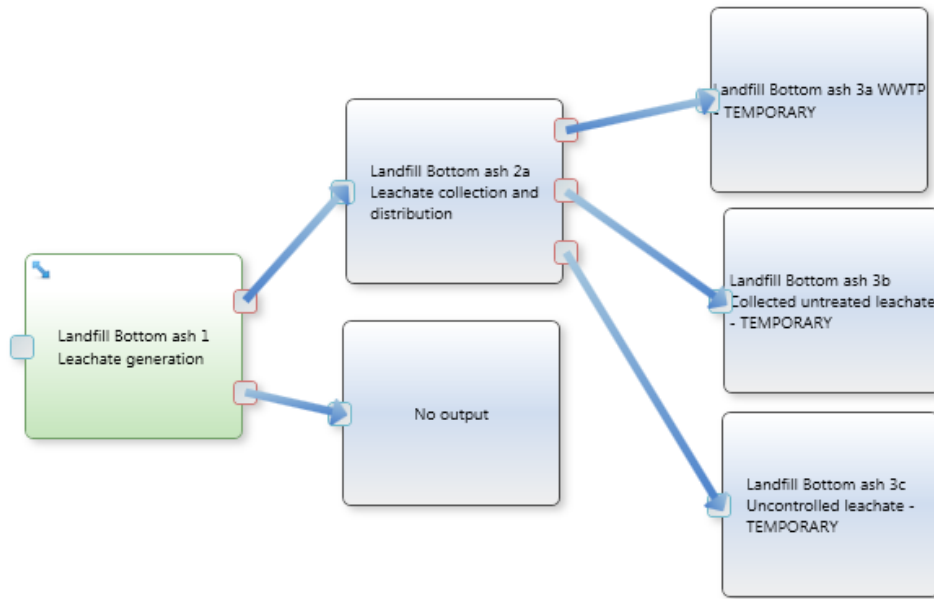

Figure 11: Scheme of the mineral landfilling model in EASETECH

3.8.4 Waste-to-energy

In different countries, the average emissions and the ancillary materials vary substantially. Unfortunately, the different methodology used (types of emissions measured, daily average, yearly average, half-hour average, etc.) made it very difficult to compare them. For this reason, all the incineration facilities are modelled based on the average Danish incinerator and the flue-gas cleaning system studied in Vestforbrænding in 2011 (Møller et al., 2013) and used in EASETECH database. Table 56 and Table 57 the external processes (ancillary material and credited energy) and the air emissions added in the model. Transfer coefficients are used to trace pollutants. All the facilities recover metals due to the high value of these material in the market (Andreasi Bassi, 2015) and 50% of Aluminium scraps and 80% of ferrous scraps are sent to recycling. All fly ashes are sent to inert landfills because modelling the impacts derived from a different utilization is not robust enough and bottom ashes treatment is neglected since in the reutilization for road construction negative and positive impacts are of minor importance (Birgisdóttir et al., 2007). This assumption was tested sending all the bottom ash to inert landfills and no significant change was observed in the overall results. Both the produced electricity and produced heat are assumed to substitute mix electricity and heat (explained in SI 0).

Table 56: External processes (ancillary material and credited energy). E_e is the efficiency for electricity production, T_e is the efficiency for heat production (different for each country).

Name	Amount	Unit
Electricity	$-E_e/3.6$	kWh/MJ Energy
Heat	$-T_e$	MJ /MJ Energy
Sodium hydroxide (NaOH)	2.4E-05	kg / kg _{ww input}
Activated Carbon	1.04E-03	kg / kg _{ww input}
Polyethylene high density granulate (PE-HD)	6E-07	kg / kg _{ww input}
Hydrated Lime, CaOH ₂	3.4E-03	kg / kg _{ww input}
Hydrogen chloride (HCl)	5.6E-06	kg / kg _{ww input}
Process water	3.97E-01	kg / kg _{ww input}
Limestone, CaCO ₃	5.67E-03	kg / kg _{ww input}
TMT 15	3.95E-4	kg / kg _{ww input}
Ammonia (NH ₃)	1.53E-3	kg / kg _{ww input}

Table 57: Emissions to air

Name	Amount	Unit
Carbon monoxide, fossil	3.30E-05	kg / kg _{ww input}
Dioxins, measured as 2,3,7,8-tetrachlorodibenzo-p-dioxin	1.80E-14	kg / kg _{ww input}
Hydrogen chloride	5.30E-06	kg / kg _{ww input}
Hydrogen fluoride	3.90E-07	kg / kg _{ww input}
Nitrogen oxides	8.49E-04	kg / kg _{ww input}
Sulfur dioxide	2.91E-06	kg / kg _{ww input}
Particulates, > 10 um	3.00E-05	kg / kg _{ww input}

3.8.4.1 Thermal efficiency: electricity and heat

The determination of the net thermal efficiency of the WtE plants for both electricity and heat production is the result of the combination of several sources.

A first estimation of the gross efficiency was calculated from the data published in the CEWEP III Report (Reimann, 2012): assuming the same average treatment load for all facilities, the number of investigated plants (Table 58) can be combined with the average gross thermal efficiencies (Table 59), finding the gross efficiencies shown in Table 60. Around 10% of the electricity generated is used for internal consumption, while the internal heat consumption is neglected (Andreasi Bassi, 2015).

Due to the characteristic of Denmark to have a very developed District Heating system, the net efficiencies for Denmark have been modified based on the information given by one of the engineers in Ramboll Danmark A/S (Andreasi Bassi, 2015): Danish net efficiency for electricity and heat production are modelled as 18% and 73%, respectively. These values are supported by the average efficiencies reported in North Europe in Reimann (2012).

Table 61 shows the net thermal efficiencies used in the baseline scenario for WtE plants.

Table 58: Total and investigated numbers and types of WtE plants (Reimann, 2012)

	DE	DK	FR	UK	IT	PL
Total n° in 2009	70	31	130	23	47	1
Investigated 2007-2010	72	26	92	4		0
CHP production [n°]	55	21	34	1	32	0
Only electricity production [n°]	9	0	40	3	15	0
Only heat production [n°]	8	5	18	0		0

Table 59: Average European gross efficiency per type of plant (Reimann, 2012) *Heat self-used to treat the MSW

	electricity generation efficiency	Heat utilisation (% heat used of total energy content)
Electricity only	21.6%	4.5*
CHP	15%	37.1%
Heat only	-	77.2%

Table 60: Gross efficiencies calculated from the data published in Reimann 2012

	DE	DK	FR	UK	IT
Gross thermal efficiency, electricity	14.16%	12.12%	14.93%	19.95%	17.11%
Gross thermal efficiency, heat	36.92%	44.81%	28.82%	9.28%	25.26%

Table 61: Net efficiencies used in the baseline

	DE	DK	FR	UK	IT
Net thermal efficiency, electricity	12.74%	18%	13.32%	17.96%	15.76%
Net thermal efficiency, heat	36.92%	73%	28.30%	9.28%	28.60%

3.8.5 MBT

Due to the lack of information on the detailed functioning of the MBT plants in Europe, several simplifications are made. Only two types of MBT plants are modelled: mechanical biological pre-treatment (MBP) and the mechanical biological stabilization (MBS). MBP (Figure 12) is constituted by a mechanical treatment followed by a biological treatment to stabilize the organic material and meet the requirement for an MBT landfill, while MBS (Figure 13) is composed of a short biological treatment, to dry the waste, and a mechanical separation of the remaining

waste. Mass balances and energy and materials consumptions are based on Erikssen and Damgaard (n.d.) where detailed information about the inputs and the outputs of the processes can be found. Due to lack of more detailed information, all PM10 emissions were modelled as 2.5<PM<10µm. This process is affected by important uncertainty due to the very few data available.

in Erikssen and Damgaard (n.d.).

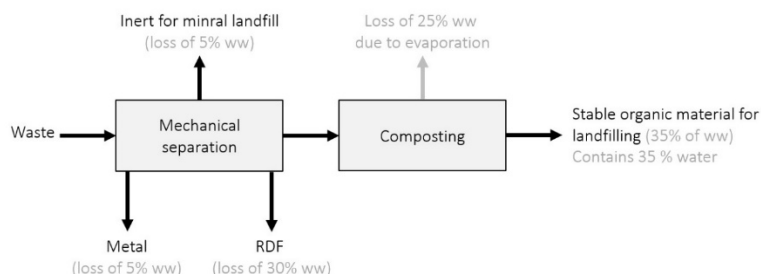

Figure 12: Mass balance of a generic MBP plant, where RDF stands for refuse derived fuel

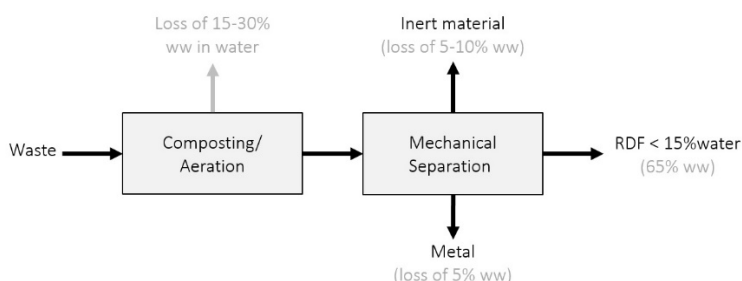

Figure 13: Mass balance of a generic MBS plant, where RDF stands for refuse derived fuel

In the modelling, only 3 countries include MBT as major treatment of the residual waste: Germany, Italy and Poland. The data regarding German MBT plants is found in Kühle-Weidemeier et al. (2007) and shown in Table 62: due to the simplifications explained above, 69% of the waste is modelled as sent to MBP and 31% to MBS. Furthermore, Gibbs et al. (2014) reported that 55% of the Italian plants are MBS and 45% anaerobic digestion but due to the problematic in modelling the process, all the plants in Italy are considered as MBP. Finally, most MBT plants in Poland are constituted by MPB of which the outputs are sent to inert landfill (Gibbs et al., 2014). Both Germany and Italy send their refuse derived fuel (RDF) to WtE plants and to cement kilns. Since cement kilns are not focus of this paper, all the RDFs are modelled to be burnt in a WtE plant with the same characteristics as described in the SI 3.8.4.

Table 62: Type of MBT used in Germany (Kühle-Weidemeier et al., 2007)

	No of plants	Waste Input [t/y]	Type of plant
MA	30	233 040	Material stream separation
MBT	33	3 082 898	Mechanical(-biological) pre-treatment prior to incineration
	Aerobic	20	
	Anaerobic	13	
MBS	12	1 361 443	Mechanical-biological stabilization (with a biological drying process)
MPS	3	463 000	Mechanical-physical stabilization (with a thermal drying process)

3.8.6 Composting

The majority of household source-sorted food waste is usually composted in-vessel (ADEME, 2013; WRAP, 2013). The process is modelled based on a datasets available in the EASETECH database; the dataset is built on data measured in a vessel composting facility in Treviso (Italy), as described in Boldrin et al. (2011), where the degradation of volatile solids (VS) and carbon (C) were estimated to be 73.5% for kitchen waste and 54.6 % for

garden waste, whereas 71% of the total N is degraded during the process. All the emissions are treated in a bio-filter which has a substantial abating effect on the two compounds. Before entering in the bio-filter, 2.2% and 83% of the degraded C and Nitrogen (N) are emitted as CH₄ and NH₃.

Table 63, Table 64 and Table 65 provide an overview of the values modelled for the composting facility. Since it is assumed that no impurities are sent to the plant, there is no output from the plant but compost.

The water content in the compost is set equal to 70.5 % (average between the values for only kitchen waste found in (Boldrin et al., 2011)). It is so high because no garden waste is added to the input material and food waste has very high initial water content.

Table 63: Diesel and electricity consumption in the composting process (Boldrin et al., 2011)

Name	Amount	Unit
Wheel loader, combustion 1L of diesel, 2003/2011	1E-03	l / kg _{ww input}
Electricity	5.3E-02	kWh / kg _{ww input}

Table 64: Emissions to the air as transformation of substances (Boldrin et al., 2011)

Material property	Transformed at (%) into	Comment
kg C bio	99.8	Carbon dioxide, non-fossil
kg C bio	0.2*0.05	Methane, non-fossil
kg C bio	0.2*0.95	Carbon dioxide, non-fossil
kg N	0.1	Nitrogen
kg N	98.5*0.01	Ammonia
kg N	1.4	Dinitrogen monoxide

Table 65: Emissions to air for the composting process (Boldrin et al., 2011)

Name	Compartment	Amount	Unit
Terpenes	air	1.22E-06	Kg / kg _{ww input}
Hydrogen sulfide	air	1.93E-07	Kg / kg _{ww input}

3.8.6.1 Use of compost

Three types of use of compost based on EASTECH database are modelled: fertilizer substitution in agriculture, peat and fertilizer substitution in gardens, and soil amendment (e.g. used in landfill, for maintenance, for landscape, etc.).

- **In agriculture:** the process is based on EASTECH database for Use-On-Land in plant farming on loam soil, where the fate of carbon (C) and nitrogen (N) is simulated by Daisy, a deterministic agro-system model (Table 66). The rate of N substitution is based on Danish regulation that defines the amount of compost that can be applied on farmlands: 20%, 100%, 100% are the substitution factors for N, K, P respectively based on the Danish farming practice (N needs to be mineralized before being absorbed by plants). The avoided application of heavy metals to the agricultural soil was estimated based on the heavy metals content of N, P, K fertilizers, while the heavy metals introduced with the compost are equivalent to the amount contained in the organic waste calculated by EASTECH. The process for compost application is built for Danish conditions, but since it was difficult to find such detailed analysis for other European countries, it is used in all Europe. In EASTECH database only two typologies of soil is modelled for compost application: loam and sandy. Loamy soil is chosen for the baseline, but a scenario analysis is made in case the compost is applied on sandy soil.
- **In gardens:** the compost is used in gardens and avoids utilization of chemical fertilizers and peat as soil amendment. The process is based on Boldrin et al. (2010). The amount of N, P, K is not calculated based on the waste composition, but according to the average content in green waste (1.76, 4.67, 5.86 g/kg_{ww input}, for N, P, K respectively). The substitution ratio is further adjusted to keep into consideration people's behaviour. In fact, Andersen et al. (2010) studied the individual behaviors of private citizens, showing that people would, to some extent, continue using peat, fertilizer or manure in the garden in addition to the compost. A weighted average of the values reported in the article set the utilization efficiency to 29%, thus only 29% of the fertilizers is substituted compared to the potential N, P, K quantity in the compost. Of the carbon contained in the compost, 15% is bound to soil after 100 years, while all C contained in substituted peat is emitted as CO₂ (53 g/kg_{ww input}). Emissions to water are shown in Table 67.

- Others (No substitution): compost used as soil amendment based on Boldrin et al. (2010). No displacement of other material is calculated and carbon sequestration in soil is not addressed. Emissions to water are shown in Table 67.

Table 68 shows the repartition of compost utilization in each of the analysed countries and their sources. Due to the very low amount of waste collected and to the lack of information in Poland, the compost is assumed to be entirely used (i.e. 100%) in agriculture.

Table 66: Distribution of biogenic carbon, nitrogen and phosphorus applying compost to agricultural soil.

Distribution of Carbon (%)		
CO ₂ (air)	CH ₄ (air)	C (soil storage)
87	0	13

Distribution of Nitrogen (%)						
N ₂ (air)	N ₂ O (air)	NH ₃ (air)	NO ₃ (leaching to GW)	NO ₃ (runoff to SW)	N (plant uptake)	N (soil storage)
52.29	1.5	0.21	10	20	6	10

Distribution of Phosphorous (%)			
P (soil storage)	PO ₃ (leaching to GW)	PO ₃ (runoff to SW)	P (plant uptake)
100	0	0	0

Table 67: Emissions to water for compost used as soil amendment (EASETECH)

Name	Amount	Unit	Name	Amount	Unit
Aluminium	1.66E-05	kg / kg _{ww input}	Magnesium	9.89E-05	kg / kg _{ww input}
Arsenic, ion	2.19E-07	kg / kg _{ww input}	Manganese	1.32E-06	kg / kg _{ww input}
Bromide	0.00E+00	kg / kg _{ww input}	Molybdenum	2.61E-07	kg / kg _{ww input}
Calcium, ion	6.66E-04	kg / kg _{ww input}	Sodium, ion	2.12E-04	kg / kg _{ww input}
Cadmium, ion	9.08E-10	kg / kg _{ww input}	Nitrate	9.46E-05	kg / kg _{ww input}
Chloride	4.99E-04	kg / kg _{ww input}	Nickel, ion	1.19E-07	kg / kg _{ww input}
Chromium, ion	2.08E-08	kg / kg _{ww input}	Lead	8.22E-08	kg / kg _{ww input}
Copper, ion	2.38E-07	kg / kg _{ww input}	Sulfate	5.00E-04	kg / kg _{ww input}
Iron, ion	2.59E-05	kg / kg _{ww input}	Antimony	4.17E-08	kg / kg _{ww input}
Mercury	1.01E-09	kg / kg _{ww input}	TOC, Total Organic Carbon	1.00E-04	kg / kg _{ww input}
Potassium, ion	1.07E-03	kg / kg _{ww input}	Zinc, ion	2.27E-06	kg / kg _{ww input}

Table 68: Percentage of compost used in agriculture, gardens and others (Note that data for Poland is assumed).

	DE	FR	UK	IT	PL
	[%]	[%]	[%]	[%]	[%]
In agriculture	62.5	80	55.2	62	100*
In garden	20.3	20	8.8	34	
Others (no substitution)	17.2		36	4	
Source	(Statistisches Bundesamt Wiesbaden, 2014)	(ADEME, 2013)	(M-E-L Research, 2008)	(Rigamonti et al., 2010)	*assumed

3.8.7 Anaerobic digestion

Anaerobic digestion is modelled based on the unit process inventory of an hypothetical "wet" plant treating source-sorted organic household waste (Møller et al., 2011) and its characteristics are shown in Table 69 and Table 70. The degradation of each fraction is built as percentage of VS content, about 70% VS degradation for organic waste; and 2% CH₄ is emitted as gas leakage from the digester. Since no impurities are sent to the plant, there is no output from the plant but digestate. The emissions from the process are constructed from measured data from a number of European biogas plants (Table 71). The digestate from the AD plant is then composted in the same composting plant described in the SI 3.8.6 and applied to agriculture soil.

Table 69: Unit process inventory for a thermophilic anaerobic digestion of 1 t (wet weight) waste (Møller et al., 2011)

Inputs	Comment
Organic waste 1000 kg	Source-sorted organic household

Diesel	0.9 l	Trucks and machinery
Electricity	18.3 kWh	Pumps, ventilators etc.
Outputs		
Gas	123Nm ³	63% CH ₄ + 37% CO ₂
Electricity	311kWh	39% engine efficiency
Heat	366kWh	46% engine efficiency
Fugitive gas loss	1-3 Nm ³	From pipes and fittings etc.

Table 70: Transformation of CO₂ and CH₄ in the AD process (Møller et al., 2011)

Material property	Transformed at (%) into	Elementary exchange	Compartment	With the conversion factor
m ³ CH ₄	98	Carbon dioxide, non-fossil	air	Mass CO ₂ /Volume of gas
m ³ CO ₂	100	Carbon dioxide, non-fossil	air	Mass CO ₂ /Volume of gas
m ³ CH ₄	2	Methane, non-fossil	air	Mass CO ₂ /Volume of gas

Table 71: Emissions to air from the AD process

Name	Compartment	Sub compartment	Amount	Unit	Per
Nitrogen oxides	air	unspecified	0.00268	kg	m ³ CH ₄
Sulfur dioxide	air	unspecified	9.5E-05	kg	m ³ CH ₄
Dinitrogen monoxide	air	unspecified	2.45E-06	kg	m ³ CH ₄
Carbon monoxide, non-fossil	air	unspecified	0.001354	kg	m ³ CH ₄

3.8.7.1 Use of digestate

The digestate enters first to a composting facility and is then applied to agricultural soil.

In this case as well loam soil is chosen, but a scenario analysis is made with sandy soil to test the importance of the soil. The application of the composted digestate on the agricultural soil is modelled as in SI 3.8.6.1. Even if the environmental impacts due to compost or to composted digestate can be different, this assumption is considered acceptable due to the low importance of AD on the overall results.

3.9 Transport

The trucks for the transport are assumed to be the same in all the countries:

- From households to initial treatment facilities (biological treatment/MRF/ incineration/MBT/landfill) trucks have a capacity between 14-20 t;
- From initial treatment to further/final treatment (MRF to recycling/landfill, from MBT to incineration/landfill/recycling, from biological treatment to compost/digestate use) trucks have capacities between 28-32t, EURO 5.

Transport data were not found for the different countries. The same distances are instead assumed in all the countries for each type of transport based on the average (Table 72) between information found for the Italian (Table 73) and the Danish experience (Table 74). Particularly high is the value found for bio-waste from households to bio-treatment (270 km). Since it is very unlikely that the wet waste is transported such a long distance on a truck, this value is set equal to the average distance for the Northern part of Italy (Rigamonti, 2007), 40 km.

In general, the transport distances are affected by great uncertainty because they are based on only 2 studies of seven countries and trains are often used. Sensitivity analysis are carried out to test the importance of these assumptions in the results.

Table 72: Average transport distances assumed in the baseline

Average transport distances for household waste		[km]
From households to MRF		80
From households to bio-treatment (composting or AD)		40
From households to incineration		45
From households to MBT		70
From households to landfill		70
From MRF to the treatment of residues (mineral landfill)		70
From incineration to bottom ash landfill		100
From MBT to incineration / inert landfill		250
Average transport distances for the organic utilization and for dry recyclables		[km]
Digestate, compost		50
Paper		433
Cardboard		455
Soft plastic (LDPE)		365
HDPE		365
PET		365
Al		450
Ferrous metals		500
Mixed metals		285
Glass		350

Table 73: Maximum distances for an average Italian situation (Rigamonti, 2007)

Maximum values for the Italian municipal waste		Km
From collection to MRF		100
From collection to composting		500
From MRF to recycling of all the dry recyclables		500
From MRF to landfill		100
From recycling/composting to landfill		100

Table 74: Average distances for the Danish municipal waste (Gibbs et al., 2014)

Average distances for Danish municipal waste		km
From bring banks to bailing plants		20
From households to bag sorting plants		20
From household to residual sorting plants		60
From household to source-sorted sorting plants		60
From household to bio-treatment		40
From household to incineration		20
From household to bailing plants		20
Average transport distances for recyclables in Denmark		km
	Recipient	
Digestate, compost		30 Landowner
Paper		365 Paper mill
Cardboard		410 Paper mill
LDPE		230 Granulate plant
HDPE		230 Granulate plant
PS		230 Granulate plant
PP		230 Granulate plant
PET		230 Granulate plant
Mixed plastic		230 Granulate plant
Al		400 Aluminium plant
Ferrous metals		500 Steel works
Mixed metals		70 Scrap metal
Glass		200 Glass recycling

3.10 Capital goods

Capital goods (CG) from collection vehicles and bins are neglected because they are assumed to be equal in all the countries.

Capital Good of the trucks is modelled with the ecoinvent process "Transport, freight, lorry 16-32 metric ton, EURO 5".

Regarding recycling processes, the same capital goods present in the substituted material in ecoinvent are used. The processes for Glass, Paper, Cardboard, PET, soft Plastic and Steel include already the capital goods in the substituted material (from ecoinvent datasets), while HDPE (assumed the same CG as PET) and Aluminium do not. The process for Aluminium recycling does not have any CG because $CG_{recyclable\ material} = CG_{recycled\ material}$. For the other materials, the quantity entered is the difference between the Capital goods of the recycling process and the avoided capital goods of the substituted material (Table 75):

$$CG_{recyclable\ material} - CG_{secondary\ material} = CG_{tot}$$

Finally, Table 76 shows the capital goods for MRF, AD, composting and incineration.

Table 75: Capital goods of recycling process

Process for CG		Unit/kg input
Glass	Packaging glass factory, RER	1.25E-10
Paper	Paper mill, integrated, RER	5.44E-11
Cardboard	Paper mill, integrated, RER	5.32E-11
PET	Chemical factory, organics, RER	3.02E-10
HDPE	Chemical factory, organics, RER	6.80E-11
mix	Wooden board factory, organic bonded boards, RER	1.96E-08
Steel	Blast oxygen furnace converter, RER	1.12E-11

Table 76: Capital goods modelled for each process imported from ecoinvent

Process	CG used	Capacity of the factory in its lifetime [t]	Unit/kg _{input}
MRF	Waste paper sorting facility construction, RER	1 650 000	6.06E-10
AD	Anaerobic digestion plant construction, for bio-waste, CH	250 000	4.00E-09
Composting	Composting facility construction, open, CH	250 000	4.00E-09
Incineration	Municipal waste incineration facility construction, CH	4000000	2.50E-10
MBT	Waste paper sorting facility construction + Composting facility construction, open	-	-
Trucks	lorry production, 16 metric ton, RER	-	3.2E-07

The capital goods of landfills is built on materials and energy consumption for building and running a 3 500 Mtonnes landfill (see Table 77 and Table 78), where leachate and gas collection, leachate management and gas treatment is included but leachate treatment is not. The process did not include asphalt, cables, soil and concrete and the production of copper, clay and gravel.

Table 77: External processes in the capital goods of landfills (Brogaard et al. 2013)

Name	Amount	Unit
Electricity	8*E-03	kWh / kg _{wet weight}
Production and Combustion of Diesel Oil in Truck	0.24*0.84/1000	kg / kg _{wet weight}
Steel Sheets (97.75% primary)	1.4E-04	kg / kg _{wet weight}
Aluminium, Al (Primary)	5.8E-08	kg / kg _{wet weight}
Polyvinylchloride resin (S-PVC)	1E-05	kg / kg _{wet weight}
Polypropylene fibres (PP)	4E-08	kg / kg _{wet weight}
Polyethylene high density granulate (PE-HD)	2.3E-04	kg / kg _{wet weight}

Table 78: Emissions to soil for the capital goods of landfills (Brogaard et al. 2013)

Name	Amount	Unit
Gravel	0.18	kg / kg _{wet weight}
Clay	0.082	kg / kg _{wet weight}
Copper, 0.99% in sulfide, Cu 0.36% and Mo 8.2E-3% in crude ore, in ground	9.87E-09	kg / kg _{wet weight}

Capital Good of all the trucks is modelled with the ecoinvent process "lorry production, 16 metric ton, RER". The Unit/kg_{input} is based on the information reported in the ecoinvent database (Weidema et al., 2015).

The environmental impacts due to the Capital Goods are heavily dependent on the material recovery after the decommissioning of the buildings (Brogaard et al., 2015, 2013). Table 79 describes the disposal processes of the capital goods processes imported from ecoinvent database. It has to be noted that usually no partial allocation of burdens from recycling processes is made in the disposal phase in ecoinvent and the system boundaries cuts off the recycling processes themselves.

Table 79: Processes imported from ecoinvent, description of the disposal process and source where the disposal processes are explained in detailed

Process	Disposal process description	References
Packaging glass factory	The disposal process included dismantling of buildings, and of technical equipment (3 melting furnaces, 3 forming machines, 3 cooling furnaces) All the metals from the melting, forming and cooling furnace go to recycling. Regarding the disposal of control unit/electronic disposal of all the previous components: from the electronic equipment large metals parts are separated and recycled, bigger plastic parts are	(Hischier, 2007a)

	separated and incinerated in MSWI, while printed wiring boards are separated and recycled in a copper smelters.	
Chemical factory, organics	The building dismantling considers three materials: concrete, rock wool and metals. Concrete and steel are 50% recycled and 50% sent to inert landfill, while rock wool is sent to final disposal. Regarding the electronic equipment: large metals parts are separated and recycled, bigger plastic parts are separated and incinerated in municipal incineration facilities, and printed wiring boards are separated and recycled in a copper smelters. Finally, the pipes are made of steel (50% recycled) and concrete (50% recycled).	(Althaus et al., 2007)
Paper mill, integrated	The dismantling/disposal of the whole infrastructure is included, but the paper machine disposal is excluded. Same disposal as "Chemical factory, organics"	(Althaus et al., 2007)
wooden board factory, organic bonded boards	The process include disposal of the plant. Waste reinforced concrete is collected, sorted and recycled.	(Werner et al., 2007)
Blast oxygen furnace converter	The infrastructure is disposed in inert material landfill, while the conveyor belts and the machines are completely recycled.	(Classen et al., 2009)
Waste paper sorting facility construction	The process includes the dismantling of the whole infrastructure for paper machines and the pulp production facility. Regarding paper machines, all metals are recycled, plastics is incinerated and electronic installations are separated in metals (recycled), plastic (incinerated) and wiring boards (recycled). Regarding the pulp production facility, the same process as "Chemical factory, organics".	(Hischier, 2007b)
Anaerobic digestion plant construction, for bio-waste	The disposal is included in the process: Reinforced concrete waste is collected, sorted ad recycled; asphalt is sent to sanitary landfill, polystyrene and polyvinylchloride are incinerated.	(Jungbluth et al., 2007)
Anaerobic digestion plant construction, for bio-waste	Same disposal as "Anaerobic digestion plant construction, for bio-waste"	(Jungbluth et al., 2007)
Composting facility construction, open	The disposal is included in the process: not reinforced concrete waste is collected, sorted ad recycled, gravel is crushed and sent to inert material landfill, reinforcing steel is recycled and glued laminated timber is incinerated (without crediting). Few processes are not considered: recycling of copper, sand, bitumen and steel and iron from the machineries.	(Nemecek and Kägi, 2007)
Municipal waste incineration facility construction, CH	The disposal is included in the process: not reinforced and reinforced concrete waste is collected, sorted ad recycled, waste bitumen sheet is incinerated. Steel recycling is not included.	(Doka, 2009)
lorry production, 16 metric ton, RER	The disposal is included in the process. The dataset includes disposal of plastic, glass, and zinc from the car shredder residues and of the mineral oil. It does not include the full recycling of the bulk material (steel, aluminium and copper), and the incineration as secondary fuel of 50% of all used tyres in Swiss cement works.	(Spielmann et al., 2007)

3.11 Energy used

Results of a LCA strongly depend on the energy used and credited in the process. This paragraph clarifies the assumptions taken in this paper.

3.11.1 Electricity

Consumed and credited electricity is modelled as the average technology used to transmit and distribute electricity and the electricity production is based according to related technology datasets in each country. The process "electricity, high voltage, production mix" is imported from the ecoinvent database (Weidema et al., 2015) modifying the geographical location. For the recycling processes, the European Network of Transmission Systems Operators for Electricity is chosen as geographical location of the process.

Table 80 shows the composition of the average mix electricity in the countries based on ecoinvent data. The fraction "Others" represent several electricity sources contributing less than 5% to the overall electricity. The composition for the European electricity and more details can be found in ecoinvent database (Weidema et al., 2015).

Table 80: Composition of the processes imported from ecoinvent for the 7 studied countries. More details can be found in ecoinvent database (Weidema et al., 2015).

	Process from ecoinvent	%
DE	Electricity production, hard coal [DE]	16.95
	Electricity production, lignite [DE]	25.77
	Electricity production, nuclear, pressure water reactor [DE]	13.21
	Electricity production, wind, 1-3MW turbine, onshore [DE]	6.77
	Heat and power co-generation, natural gas, conventional power plant, 100MW electrical [DE]	8.91
	Others	28.41
DK	Electricity production, wind, <1MW turbine, onshore [DK]	14.77
	Electricity production, wind, 1-3MW turbine, offshore [DK]	8.09
	Electricity production, wind, 1-3MW turbine, onshore [DK]	10.09
	Heat and power co-generation, hard coal [DK]	35.30
	Heat and power co-generation, natural gas, conventional power plant, 100MW electrical [DK]	13.38
	Heat and power co-generation, wood chips, 6667 kw, state-of-the-art 2014 [DK]	11.41
Other	6.96	
FR	Electricity production, hydro, run-of-river [FR]	9.28
	Electricity production, nuclear, pressure water reactor [FR]	76.02
	Other	14.70
UK	Electricity production, hard coal [GB]	39.95
	Electricity production, natural gas, combined cycle power plant [GB]	9.35
	Electricity production, natural gas, conventional power plant [GB]	13.57
	Electricity production, nuclear, boiling water reactor [GB]	16.75
	Other	20.38
IT	Electricity production, hard coal [IT]	17.36
	Electricity production, hydro, reservoir, alpine region [IT]	10.04
	Electricity production, hydro, run-of-river [IT]	5.65
	Electricity production, natural gas, combined cycle power plant [IT]	14.99
	Heat and power co-generation, natural gas, combined cycle power plant, 400MW electrical [IT]	16.93
	Heat and power co-generation, natural gas, conventional power plant, 100MW electrical [IT]	10.43
	Heat and power co-generation, oil [IT]	5.52
Other	19.08	
PL	Heat and power co-generation, hard coal [PL]	49.23
	Heat and power co-generation, lignite [PL]	33.02
	Heat and power co-generation, wood chips, 6667 kw, state-of-the-art 2014 [PL]	6.40
	Other	11.35
EL	Electricity production, hydro, run-of-river [GR]	8.30
	Electricity production, lignite [GR]	36.58
	Electricity production, natural gas, combined cycle power plant [GR]	15.27
	Electricity production, oil [GR]	8.38
	Heat and power co-generation, lignite [GR]	14.94
	Other	16.53

3.11.2 Heat

Used and credited heat modelling was more complex than electricity modelling because no pre-mix processes were found in literature or in the ecoinvent database. Heat modelling is very important especially regarding energy crediting in the WtE plants.

Two datasets were needed: firstly the gross heat production by fuel in each country and secondly the processes to import from ecoinvent to fit the heat composition.

The gross heat production by fuel in each country was found in the Electricity and heat statistics published in 2013 by Eurostat (Eurostat, 2013). This document shows data on the gross heat production by main activity producers vs autoproducers and heat only vs CHP, by country and by fuel in the period 1990-2013. 8 major fuel groups were there considered: solid fuels, crude oil and petroleum products, natural gas and derived gases, nuclear, renewable energies, waste non-renewable, electricity, other. Each fuel groups was divided in specific fuels (Table 81).

Table 81: Major fuel groups and specific fuels considered for the heat production in Eurostat (2013)

Major fuel groups	Specific fuel
Solid fuels	Anthracite
	Coking Coal
	Other Bituminous Coal
	Sub-Bituminous Coal
	Lignite/Brown Coal
	Peat
	Patent Fuel
	Coke Oven Coke
	Gas Coke
	Coal Tar
	BKB
	Oil shale and oil sands
	Peat products
Crude oil and petroleum products	Crude Oil
	NGL (Natural Gas Liquids)
	Refinery Gas
	LPG (Liquefied Petroleum Gases)
	Naphtha
	Kerosene Type Jet Fuel
	Other Kerosene
	Gas Diesel Oil
	Residual Fuel Oil
	Bitumen
	Petroleum Coke
	Other Oil Products
Natural gas and derived gases	Natural Gas
	Gas Works Gas
	Coke Oven Gas
	Blast Furnace Gas
	Other Recovered Gases
Nuclear	Nuclear
Renewable energies	Solar
	Solid biofuels excluding charcoal
	Biogases
	Municipal Waste (Renewable)
	Biodiesels
	Other Liquid Biofuels
Waste (non-renewable)	Geothermal
	Industrial Waste
Electricity	Municipal Waste (Non-Renewable)
	Heat Pumps
Other	Electric Boilers
	Heat from Chemical Sources
	Other Sources

Table 82 shows the percentage of gross heat produced by major fuel groups in 2013 and Table 83 the composition of the major fuel groups by specific fuel. The sum of the percentages is not always equal to 100% because major fuel groups with a contribution lower than 5% of the total heat produced and specific fuels with a contribution lower than 5% of the major heat group were not considered. The results were then normalised to 100%.

Table 82: Gross heat production by major fuel groups in 2013 based on Eurostat (2013)

	DE	DK	FR	UK	IT	PL	EL
Solid fuels	34%	24%	8%	15%		84%	99%
Crude oil and petroleum products			8%		21%		
Natural gas and derived gases	44%	22%	52%	78%	61%	9%	
Renewable energies	12%	43%	27%		16%		
Waste (non-renewable)	7%	8%					
TOT	92%	97%	94%	91%	95%	90%	99%

Table 83: Gross heat production by major fuel groups and specific fuel composition of the major fuel groups in 2013 based on Eurostat (2013)

	DE	DK	FR	UK	IT	PL	EL
Solid fuels	34%	24%	8%	15%		84%	99%
Other Bituminous Coal	64%	100%	100%	100%		97%	
Lignite/Brown Coal	22%						100%
Other	14%					3%	
Crude oil and petroleum products			8%		21%		
Refinery Gas			39%		40%		
Residual Fuel Oil			52%		25%		
Petroleum Coke					7%		
Other Oil Products					24%		
Other			9%		4%		
Natural gas and derived gases	44%	22%	52%	78%	61%	9%	
Natural Gas	100%	100%	100%	97%	98%	65%	
Coke Oven Gas						9%	
Blast Furnace Gas						17%	
Other				3%	2%	9%	
Renewable energies	12%	43%	27%		16%		
Solid biofuels excluding charcoal	39%	73%	67%		62%		
Biogases	8%				24%		
Municipal Waste (Renewable)	52%	23%	19%		10%		
Geothermal			12%				
Other	1%	4%	2%		4%		
Waste (non-renewable)	7%	8%					
Industrial Waste	16%	0%					
Municipal Waste (Non-Renewable)	84%	100%					
TOT	92%	97%	94%	91%	95%	90%	99%

Table 84 shows the correspondence between the fuel in the data collected by Eurostat and the processes imported from ecoinvent. In this step, the following assumptions were made:

- The source "Hard coal" in ecoinvent includes anthracite, coking coal and other bituminous coal according to the definition of the IEA electricity information 2014.
- Heat production from geothermal in FR is neglected because no processes in ecoinvent were found (3% of the tot heat generation)
- The heat produced from "other bituminous coal" in FR (8%) and UK (15%) was modelled with the process from DE due to the lack of this specific process
- All the specific fuels included in "Crude oil and petroleum products" were modelled as "heat and power co-generation, oil" due to the lack of more specific processes in ecoinvent.
- All waste incineration (industrial, renewable and non-renewable) was modelled as "heat, from municipal waste incineration to generic market for heat district or industrial, other than natural gas" due to the lack of more specific processes in ecoinvent.
- All the solid biofuel are considered wood due to the lack of more specific information.

Table 84: correspondence between the fuel in the Eurostat data and the processes imported from ecoinvent

Fuels from Eurostat	Process from ecoinvent
Solid fuels	
Other Bituminous Coal	Heat and power co-generation, hard coal
Lignite/Brown Coal	Heat and power co-generation, lignite
Crude oil and petroleum products	
Refinery Gas	Heat and power co-generation, oil
Residual Fuel Oil	Heat and power co-generation, oil
Petroleum Coke	Heat and power co-generation, oil
Other Oil Products	Heat and power co-generation, oil
Natural gas and derived gases	
Natural Gas	Heat and power co-generation, natural gas, conventional cycle power plant, 400MW electrical
Coke Oven Gas	Treatment of coal gas, in power plant
Blast Furnace Gas	Treatment of blast furnace gas, in power plant
Renewable energies	
Solid biofuels excluding charcoal	Heat and power co-generation, wood chips, 6667 kw, state-of-the-art
Biogases	Heat and power co-generation, biogas, gas engine
Municipal Waste (Renewable)	Heat, from municipal waste incineration to generic market for heat district or industrial, other than natural gas
Geothermal	-
Waste (non-renewable)	
Industrial Waste	Heat, from municipal waste incineration to generic market for heat district or industrial, other than natural gas
Municipal Waste (Non-Renewable)	Heat, from municipal waste incineration to generic market for heat district or industrial, other than natural gas

Merging the data collected by Eurostat and the processes available in ecoinvent, the average mix heat processes were modelled as shown in Table 85.

Table 85: average mix heat production modelled in the baseline

Processes imported from ecoinvent	DE	DK	FR	UK	IT	PL	EL
Heat and power co-generation, hard coal	24%	25%	9%	16%		91%	
Heat and power co-generation, lignite	8%						100%
Heat and power co-generation, natural gas, conventional power plant, 100MW electrical	47%	23%	57%	84%	63%	7%	
Treatment of blast furnace gas, in power plant						2%	
Treatment of coal gas, in power plant						1%	
Heat and power co-generation, oil			8%		21%		
Heat and power co-generation, wood chips, 6667 kw, state-of-the-art 2014	5%	33%	20%		10%		
Heat and power co-generation, biogas, gas engine	1%				4%		
Heat, from municipal waste incineration to generic market for heat district or industrial, other than natural gas	15%	19%	5%		2%		
TOT	100%	100%	100%	100%	100%	100%	100%

Regarding the heat used in the recycling processes, European average mix should be used. Even if it was possible to calculate the European gross heat production based on Eurostat, no representative processes were found in ecoinvent setting Europe as geographical location.

For overtake this issue, an average European heat was calculated based on the total gross heat produced in each of the countries studied in respect of the sum of the heat produced in the 7 countries. By comparing the information resumed in Table 85 and in Table 86, the average European heat was then modelled. All the fuels that contributed less than 1% to the overall European heat were not considered. Table 87 shows the modelled European heat used for recycling processes. The composition was then normalized to 100%.

Table 86: Gross heat production in TJ (Eurostat, 2013). The tot is the sum of the heat produced in the 7 countries.

	DE	DK	FR	UK	IT	PL	EL	TOT
Gross heat production [TJ]	135 851	488 311	124 226	60 761	216 409	303 872	1 738	1 331 168
% compared to the total	10%	37%	9%	5%	16%	23%	0%	

Table 87: Average European heat modelled by fuel and by country

Name	%
Heat and power co-generation, hard coal_DE	9
Heat and power co-generation, lignite_DE	3
Heat and power co-generation, natural gas, conventional power plant, 100MW electrical _DE	18
Heat and power co-generation, wood chips, 6667 kw, state-of-the-art 2014_DE	2
Heat, from municipal waste incineration to generic market for heat district or industrial, other than natural gas_DE	6
Heat and power co-generation, hard coal_DK	3
Heat and power co-generation, natural gas, conventional power plant, 100MW electrical_DK	3
Heat and power co-generation, wood chips, 6667 kw, state-of-the-art 2014_DK	4
Heat, from municipal waste incineration to generic market for heat district or industrial, other than natural gas_DK	2
Heat and power co-generation, natural gas, conventional power plant, 100MW electrical_FR	6
Heat and power co-generation, wood chips, 6667 kw, state-of-the-art 2014_FR	2
Heat and power co-generation, natural gas, conventional power plant, 100MW electrical_UK	4
Heat and power co-generation, natural gas, conventional power plant, 100MW electrical_IT	11
Heat and power co-generation, oil_IT	4
Heat and power co-generation, wood chips, 6667 kw, state-of-the-art 2014_IT	2
Heat and power co-generation, hard coal_PL	22
Heat and power co-generation, natural gas, conventional power plant, 100MW electrical_PL	2

3.12 Summary of the data quality

In order to easily quantify the data quality of the data on which the model is based, all processes were assigned a value from 1 to 5 different quality indicators as described in SI 2.6. The indicators are temporal, geographical and technological representativeness, completeness and reliability. The overall data quality or Data Quality Rating (DQR) for each process was calculated based on EC-JRC (2011).

Following is:

- Scoring of data quality for each data set in each country
- Scoring of data quality for recycling processes
- Scoring of data quality for each stage in each country
- Conclusions on the data quality

Each DQR was assigned a colour based on the overall data quality level Table 88.

Table 88: Overall quality level of a data set according to the DQR (EC-JRC

, 2011) and assigned colour in the data quality scoring

Overall data quality rating (DQR)	Overall data quality level	Colour
< 1.6	High quality	
>1.6 to 3	Basic quality	
>3 to 4	Data estimate	

3.12.1 Scoring of data quality for each data set in each country

Germany

Process	Data	Technological representativeness	Geographical representativeness	Time-related representativeness	Completeness	Reliability	DQR
HSW generation	HSW composition	1.5	1.0	2.5	4.0	3.0	3.1
	Chemical composition	1.5	1.0	3.0	1.0	1.0	2.2
Household sorting	HSW sorting efficiency	1.5	1.0	1.0	1.0	2.0	1.6
	Composition of the collected fractions	1.0	1.0	1.0	5.0	4.0	3.6
	Types of collection schemes	1.0	1.0	1.0	1.0	1.0	1.0
Collection	Fuel consumption	2.0	3.0	4.0	4.0	2.0	3.4
MRF	Sorting efficiencies	2.0	3.0	3.0	3.0	2.0	2.8
	Diesel consumption	2.0	3.0	1.0	1.0	1.0	2.2
	Electricity consumption	2.0	3.0	1.0	1.0	1.0	2.2
	Wire consumption	2.0	3.0	1.0	1.0	1.0	2.2
	Capital goods	5.0	2.0	1.0	4.0	2.0	3.8
Waste treatment	% of residual waste going to different treatments	1.5	1.0	1.0	1.0	2.0	1.6
	% of food waste going to different treatments	1.5	1.0	1.0	1.0	2.0	1.6
Recycling	Paper	1.8	1.0	2.0	2.3	2.5	2.2
	Cardboard	2.0	1.0	2.0	2.3	2.5	2.2
	Glass	1.8	2.2	2.4	2.6	2.4	2.4
	PET	1.8	1.0	2.3	2.8	2.0	2.3
	HDPE	1.8	1.0	2.3	2.8	1.8	2.3
	Soft Plastic	2.8	1.0	2.0	3.3	3.3	2.8
	Al	1.8	1.9	2.3	2.5	1.8	2.2
	Steel	2.5	1.8	2.2	2.7	2.4	2.5
Mineral landfill	Leachate and emissions	2.5	3.0	1.0	4.0	3.0	3.3
	Construction and operation	5.0	3.0	1.0	2.0	2.0	3.7
WtE	Transfer coefficients	2.0	3.0	2.0	4.0	1.5	3.2
	Emissions to air	2.0	3.0	2.0	4.0	1.5	3.2
	Ancillary materials consumption	2.0	3.0	2.0	4.0	1.5	3.2
	Metals recovery efficiency	2.0	3.0	2.0	4.0	1.5	3.2
	Net thermal efficiency, electricity	1.0	1.0	2.0	1.0	2.0	1.7
	Net thermal efficiency, heat	1.0	1.0	2.0	1.0	2.0	1.7
	Capital goods	2.5	3.0	1.0	1.0	1.0	2.3
MBP/MBS	Transfer coefficient	3.0	1.0	3.0	4.0	4.0	3.4
	Energy consumption	3.0	1.0	3.0	4.0	4.0	3.4
	Ancillary material consumption	3.0	1.0	3.0	4.0	4.0	3.4
	Emissions to air and water	3.0	1.0	3.0	4.0	4.0	3.4
	Capital goods	5.0	2.5	1.0	2.5	2.0	3.7
Composting	Transfer coefficients	2.0	3.0	2.5	2.0	1.0	2.5
	Energy consumption	2.0	3.0	3.0	2.0	1.0	2.6
	Ancillary material consumption	2.0	3.0	3.0	2.0	1.0	2.6
	Emissions to air and water	2.0	3.0	3.0	2.0	1.0	2.6
	% of compost going to different destinations	2.0	1.0	1.0	2.0	2.0	1.8
	Type of soil where the compost is applied: loam or sandy	5.0	1.0	1.0	5.0	4.0	4.0
	Capital goods	3.0	3.0	1.0	1.0	2.0	2.4
AD	Transfer coefficients	2.0	3.0	2.5	3.0	2.0	2.7
	Energy consumption	2.0	3.0	3.0	4.0	2.0	3.3
	Ancillary material consumption	2.0	3.0	3.0	4.0	2.0	3.3
	Emissions to air and water	2.0	3.0	2.5	4.0	2.0	3.3
	Electricity and heat efficiency	2.0	3.0	3.0	4.0	3.0	3.4
	% of composted digestate going to different destinations	2.0	1.0	1.0	2.0	2.0	1.8
	Type of soil where the digestate is applied: loam or sandy	5.0	1.0	1.0	5.0	4.0	4.0
	Capital goods	3.0	3.0	1.0	2.0	2.0	2.6
Transport	Types of trucks	4.0	1.0	2.5	1.0	2.0	2.9
	Distances	1.0	3.0	3.0	2.0	2.0	2.6
	Capital good of the trucks	3.0	2.0	1.0	2.0	2.0	2.4

Denmark

Process	Data	Technological representativeness	Geographical representativeness	Time-related representativeness	Completeness	Reliability	DOR
HSW generation	HSW composition	1.0	1.0	4.0	3.0	3.0	3.1
	Chemical composition	1.5	1.0	3.0	1.0	1.0	2.2
Household sorting	HSW sorting efficiency	2.0	1.0	1.0	4.0	2.0	2.9
	Composition of the collected fractions	1.0	1.0	1.0	5.0	4.0	3.6
	Types of collection schemes	2.0	1.0	1.0	2.0	2.0	1.8
Collection	Fuel consumption	2.0	1.0	4.0	4.0	2.0	3.2
MRF	Sorting efficiencies	2.0	3.0	3.0	3.0	2.0	2.8
	Diesel consumption	2.0	3.0	2.0	1.0	1.0	2.3
	Electricity consumption	2.0	3.0	1.0	1.0	1.0	2.2
	Wire consumption	2.0	3.0	1.0	1.0	1.0	2.2
	Capital goods	5.0	2.0	1.0	4.0	2.0	3.8
Waste treatment	% of residual waste going to different treatments	3.0	1.0	1.0	3.0	2.0	2.4
Recycling	Paper	1.8	1.0	2.0	2.3	2.5	2.2
	Cardboard	2.0	1.0	2.0	2.3	2.5	2.2
	Glass	1.8	2.2	2.4	2.6	2.4	2.4
	PET	1.8	1.0	2.3	2.8	2.0	2.3
	HDPE	1.8	1.0	2.3	2.8	1.8	2.3
	Soft Plastic	2.8	1.0	2.0	3.3	3.3	2.8
	Al	1.8	1.9	2.3	2.5	1.8	2.2
	Steel	2.5	1.8	2.2	2.7	2.4	2.5
Mineral landfill	Leachate and emissions	2.5	1.0	1.0	4.0	3.0	3.3
	Construction and operation	5.0	2.0	1.0	2.0	2.0	3.7
WtE	Transfer coefficients	2.5	1.0	2.0	4.0	1.5	3.0
	Emissions to air	2.5	1.0	2.0	4.0	1.5	3.0
	Ancillary materials consumption	2.5	1.0	2.0	4.0	1.5	3.0
	Metals recovery efficiency	2.0	1.0	2.0	4.0	1.5	2.9
	Net thermal efficiency, electricity	1.0	1.0	2.0	2.0	3.0	2.3
	Net thermal efficiency, heat	1.0	1.0	2.0	2.0	3.0	2.3
	Capital goods	2.5	3.0	1.0	1.0	1.0	2.3
Transport	Types of trucks	4.0	1.0	2.5	1.0	2.0	2.9
	Distances	1.0	3.0	3.0	2.0	2.0	2.6
	Capital good of the trucks	3.0	2.0	1.0	2.0	2.0	2.4

France

Process	Data	Technological representativeness	Geographical representativeness	Time-related representativeness	Completeness	Reliability	DDR	
HSW generation	HSW composition	1.5	1.0	2.0	1.0	1.5	1.7	
	Chemical composition	1.0	1.0	3.0	1.0	1.0	2.1	
Household sorting	HSW sorting efficiency	1.5	1.0	2.0	1.0	2.0	1.7	
	Composition of the collected fractions	1.5	1.0	2.0	1.0	2.0	1.7	
	Types of collection schemes	1.5	1.0	2.0	1.0	1.0	1.6	
Collection	Fuel consumption	2.0	3.0	4.0	4.0	2.0	3.4	
MRF	Sorting efficiencies	2.0	3.0	3.0	3.0	2.0	2.8	
	Diesel consumption	2.0	3.0	2.0	1.0	1.0	2.3	
	Electricity consumption	2.0	3.0	1.0	1.0	1.0	2.2	
	Wire consumption	2.0	3.0	1.0	1.0	1.0	2.2	
	Capital goods	5.0	2.0	1.0	4.0	2.0	3.8	
Waste treatment	% of residual waste going to different treatments	1.5	1.0	2.0	2.0	2.0	1.8	
	% of food waste going to different treatments	1.0	1.0	1.0	3.0	3.0	2.3	
Recycling	Paper	1.8	1.0	2.0	2.3	2.5	2.2	
	Cardboard	2.0	1.0	2.0	2.3	2.5	2.2	
	Glass	1.8	2.2	2.4	2.6	2.4	2.4	
	PET	1.8	1.0	2.3	2.8	2.0	2.3	
	HDPE	1.8	1.0	2.3	2.8	1.8	2.3	
	Soft Plastic	2.8	1.0	2.0	3.3	3.3	2.8	
	Al	1.8	1.9	2.3	2.5	1.8	2.2	
Landfill	Construction and operation	2.5	3.0	1.0	2.0	2.0	2.5	
		Decay rates and order of degradation	2.0	3.0	2.0	3.0	2.0	2.7
		Weather conditions	1.0	1.0	1.0	1.0	1.0	1.0
	Gas	Addition of trace substances	2.0	2.0	4.0	3.5	2.0	3.3
		Gas collection rate	2.0	1.0	1.0	2.0	2.0	1.8
		Gas utilization rate	2.0	1.0	1.0	2.0	2.0	1.8
		Types of gas utilization (electricity or heat)	2.0	1.0	1.5	1.0	1.0	1.6
		Emissions from different landfill gas treatment technologies	2.0	2.5	2.5	3.5	3.0	3.1
		Oxidation rates in the 3 top covers	1.0	3.0	2.5	3.5	3.0	3.0
	Leachate	Net infiltration rate (leachate generation)	2.0	2.5	1.0	3.5	2.0	2.8
		Concentration of trace substances	2.0	2.5	2.5	3.5	2.5	3.0
		Collection efficiency	2.0	2.5	1.0	3.5	2.0	2.8
		Removal efficiencies	2.0	2.0	2.5	3.5	2.5	2.9
		Natural leachate attenuation rates	2.0	2.0	2.0	3.5	2.5	2.9
Mineral landfill	Leachate and emissions	2.5	3.0	1.0	4.0	3.0	3.3	
	Construction and operation	5.0	3.0	1.0	2.0	2.0	3.7	
WtE	Transfer coefficients	2.0	3.0	2.0	4.0	1.5	3.2	
	Emissions to air	2.0	3.0	2.0	4.0	1.5	3.2	
	Ancillary materials consumption	2.0	3.0	2.0	4.0	1.5	3.2	
	Metals recovery efficiency	2.0	3.0	2.0	4.0	1.5	3.2	
	Net thermal efficiency, electricity	1.0	1.0	2.0	1.0	2.0	1.7	
	Net thermal efficiency, heat	1.0	1.0	2.0	1.0	2.0	1.7	
	Capital goods	2.5	3.0	1.0	1.0	1.0	2.3	
Composting	Transfer coefficients	2.0	3.0	2.5	2.0	1.0	2.5	
	Energy consumption	2.0	3.0	3.0	2.0	1.0	2.6	
	Ancillary material consumption	2.0	3.0	3.0	2.0	1.0	2.6	
	Emissions to air and water	2.0	3.0	3.0	2.0	1.0	2.6	
	% of compost going to different destinations	2.0	1.0	1.0	2.0	2.0	1.8	
	Type of soil where the compost is applied:	5.0	1.0	1.0	5.0	4.0	4.0	
	Capital goods	3.0	3.0	1.0	1.0	2.0	2.4	
Transport	Types of trucks	4.0	1.0	2.5	1.0	2.0	2.9	
	Distances	1.0	3.0	3.0	2.0	2.0	2.6	
	Capital good of the trucks	3.0	2.0	1.0	2.0	2.0	2.4	

UK

Process		Data	Technological representativeness	Geographical representativeness	Time-related representativeness	Completeness	Reliability	DOR
HSW generation	HSW composition		1.0	2.0	1.0	1.0	1.5	1.6
	Chemical composition		1.0	1.0	3.0	1.0	1.0	2.1
Household sorting	HSW sorting efficiency		1.5	1.0	2.0	1.0	2.0	1.7
	Composition of the collected fractions		1.5	1.0	2.0	1.0	2.0	1.7
	Types of collection schemes		1.5	1.0	2.0	1.0	1.0	1.6
Collection	Fuel consumption		2.0	3.0	4.0	4.0	2.0	3.4
MRF	Sorting efficiencies		2.0	3.0	3.0	3.0	2.0	2.8
	Diesel consumption		2.0	3.0	2.0	1.0	1.0	2.3
	Electricity consumption		2.0	3.0	1.0	1.0	1.0	2.2
	Wire consumption		2.0	3.0	1.0	1.0	1.0	2.2
	Capital goods		5.0	2.0	1.0	4.0	2.0	3.8
Waste treatment	% of residual waste going to different treatments		1.5	1.0	1.0	1.0	2.0	1.6
	% of food waste going to different treatments		1.5	1.0	1.0	2.0	2.0	1.7
Recycling	Paper		1.8	1.0	2.0	2.3	2.5	2.2
	Cardboard		2.0	1.0	2.0	2.3	2.5	2.2
	Glass		1.8	2.2	2.4	2.6	2.4	2.4
	PET		1.8	1.0	2.3	2.8	2.0	2.3
	HDPE		1.8	1.0	2.3	2.8	1.8	2.3
	Soft Plastic		2.8	1.0	2.0	3.3	3.3	2.8
	Aluminium		1.8	1.9	2.3	2.5	1.8	2.2
	Steel		2.3	1.8	2.2	2.7	2.4	2.5
Landfill		Construction and operation	2.5	3.0	1.0	2.0	2.0	2.5
		Decay rates and order of degradation	2.0	3.0	2.0	3.0	2.0	2.7
		Weather conditions	1.0	1.0	1.0	1.0	1.0	1.0
	Gas	Addition of trace substances (concentration of trace gasses in the landfill)	2.0	2.0	4.0	3.5	2.0	3.3
		Gas collection rate	2.0	1.0	1.0	2.0	2.0	1.8
		Gas utilization rate	2.0	1.0	1.0	2.0	2.0	1.8
		Types of gas utilization (electricity or heat)	2.0	1.0	1.0	1.0	1.0	1.6
		Emissions from different landfill gas treatment technologies	2.0	2.5	2.5	3.5	3.0	3.1
		Oxidation rates in the top covers	1.0	3.0	2.5	3.5	3.0	3.0
	Leachate	Net infiltration rate (leachate generation)	2.0	2.5	1.0	3.5	2.0	2.8
		Concentration of trace substances	2.0	2.5	2.5	3.5	2.5	3.0
		Collection efficiency	2.0	2.5	1.0	3.5	2.0	2.8
		Removal efficiencies	2.0	2.0	2.5	3.5	2.5	2.9
Mineral landfill	Natural leachate attenuation rates		2.0	2.0	2.0	3.5	2.5	2.9
	Leachate and emissions		2.5	3.0	1.0	4.0	3.0	3.3
WtE	Construction and operation		5.0	3.0	1.0	2.0	2.0	3.7
	Transfer coefficients		2.0	3.0	2.0	4.0	1.5	3.2
	Emissions to air		2.0	3.0	2.0	4.0	1.5	3.2
	Ancillary materials consumption		2.0	3.0	2.0	4.0	1.5	3.2
	Metals recovery efficiency		2.0	3.0	2.0	4.0	1.5	3.2
	Net thermal efficiency, electricity		1.0	1.0	2.0	2.0	2.0	1.8
	Net thermal efficiency, heat		1.0	1.0	2.0	2.0	2.0	1.8
Composting	Capital goods		2.5	3.0	1.0	1.0	1.0	2.3
	Transfer coefficients		2.0	3.0	2.5	2.0	1.0	2.5
	Energy consumption		2.0	3.0	3.0	2.0	1.0	2.6
	Ancillary material consumption		2.0	3.0	3.0	2.0	1.0	2.6
	Emissions to air and water		2.0	3.0	3.0	2.0	1.0	2.6
% of compost going to different destinations		2.0	1.0	1.0	2.0	2.0	1.8	

	Type of soil where the compost is applied: loam or sandy	5.0	1.0	1.0	5.0	4.0	4.0
	Capital goods	3.0	3.0	1.0	1.0	2.0	2.4
Transport	Types of trucks	4.0	1.0	2.5	1.0	2.0	2.9
	Distances	1.0	3.0	3.0	2.0	2.0	2.6
	Capital good of the trucks	3.0	2.0	1.0	2.0	2.0	2.4

Italy

Process	Data	Technological	Geographical	Time-related	Completeness	Reliability	DOR	
		representativeness	representativeness	representativeness				
HSW generation	HSW composition	1.5	1.0	1.5	4.0	3.0	3.0	
	Chemical composition	1.0	1.0	3.0	1.0	1.0	2.1	
Household sorting	HSW sorting efficiency	1.5	1.0	1.0	3.0	3.0	2.4	
	Composition of the collected fractions	1.0	1.0	1.0	5.0	4.0	3.6	
	Types of collection schemes	1.5	1.0	2.0	1.0	2.0	1.7	
Collection	Fuel consumption	2.0	3.0	4.0	4.0	2.0	3.4	
MRF	Sorting efficiencies	1.5	2.0	3.0	3.0	2.0	2.6	
	Diesel consumption	1.5	3.0	2.0	1.0	1.0	2.3	
	Electricity consumption	1.5	3.0	1.0	1.0	1.0	2.2	
	Wire consumption	1.5	3.0	1.0	1.0	1.0	2.2	
Waste treatment	Capital goods	5.0	2.0	1.0	4.0	2.0	3.8	
	% of residual waste going to different treatments	1.5	1.0	1.0	2.0	2.0	1.7	
Recycling	% of food waste going to different treatments	1.5	1.0	1.0	2.0	3.0	2.3	
	Paper	1.8	1.0	2.0	2.3	2.5	2.2	
	Cardboard	2.0	1.0	2.0	2.3	2.5	2.2	
	Glass	1.8	2.2	2.4	2.6	2.4	2.4	
	PET	1.8	1.0	2.3	2.8	2.0	2.3	
	HDPE	1.8	1.0	2.3	2.8	1.8	2.3	
	Soft Plastic	2.8	1.0	2.0	3.3	3.3	2.8	
	Aluminium	1.8	1.9	2.3	2.5	1.8	2.2	
Landfill	Steel	2.3	1.8	2.2	2.7	2.4	2.5	
	Construction and operation	2.5	3.0	1.0	2.0	2.0	2.5	
	Decay rates and order of degradation	2.0	3.0	2.0	3.0	2.0	2.7	
	Weather conditions	1.0	1.0	1.0	1.0	1.0	1.0	
	Gas	Addition of trace substances	2.0	2.0	4.0	3.5	2.0	3.3
		Gas collection rate	2.0	3.0	1.5	4.0	3.5	3.3
		Gas utilization rate	2.0	3.0	1.5	4.0	3.5	3.3
		Types of gas utilization (electricity or heat)	2.0	1.0	1.5	4.0	3.5	3.1
		Emissions from different landfill gas treatment technologies	2.0	2.5	2.5	3.5	3.0	3.1
		Oxidation rates in the top covers	1.0	3.0	2.5	3.5	3.0	3.0
	Leachate	Net infiltration rate (leachate generation)	2.0	2.5	1.0	3.5	2.0	2.8
		Concentration of trace substances	2.0	2.5	2.5	3.5	2.5	3.0
		Collection efficiency	2.0	2.5	1.0	3.5	2.0	2.8
		Removal efficiencies	2.0	2.0	2.5	3.5	2.5	2.9
		Natural leachate attenuation rates	2.0	2.0	2.0	3.5	2.5	2.9
Mineral landfill	Leachate and emissions	2.5	3.0	1.0	4.0	3.0	3.3	
	Construction and operation	5.0	3.0	1.0	2.0	2.0	3.7	
WtE	Transfer coefficients	2.0	3.0	2.0	4.0	1.5	3.2	
	Emissions to air	2.0	3.0	2.0	4.0	1.5	3.2	
	Ancillary materials consumption	2.0	3.0	2.0	4.0	1.5	3.2	
	Metals recovery efficiency	2.0	3.0	2.0	4.0	1.5	3.2	
	Net thermal efficiency, electricity	1.0	1.0	2.0	1.0	2.0	1.7	
	Net thermal efficiency, heat	1.0	1.0	2.0	1.0	2.0	1.7	
MBP	Capital goods	2.5	3.0	1.0	1.0	1.0	2.3	
	Transfer coefficient	3.0	3.0	3.0	4.0	4.0	3.7	
	Energy consumption	3.0	3.0	3.0	4.0	4.0	3.7	

	Ancillary material consumption	3.0	3.0	3.0	4.0	4.0	3.7
	Emissions to air and water	3.0	3.0	3.0	4.0	4.0	3.7
	Capital goods	5.0	3.0	1.3	2.5	2.8	3.8
Composting	Transfer coefficients	2.0	1.5	2.5	2.0	1.0	2.1
	Energy consumption	2.0	1.0	3.0	2.0	1.0	2.3
	Ancillary material consumption	2.0	1.0	3.0	2.0	1.0	2.3
	Emissions to air and water	2.0	1.0	3.0	2.0	1.0	2.3
	% of compost going to different destinations	2.0	1.0	1.0	2.0	2.0	1.8
	Type of soil where the compost is applied: loam or sandy	5.0	1.0	1.0	5.0	4.0	4.0
	Capital goods	3.0	3.0	1.0	1.0	2.0	2.4
AD	Transfer coefficients	2.0	3.0	2.5	3.0	2.0	2.7
	Energy consumption	2.0	3.0	3.0	4.0	2.0	3.3
	Ancillary material consumption	2.0	3.0	3.0	4.0	2.0	3.3
	Emissions to air and water	2.0	3.0	2.5	4.0	2.0	3.3
	Electricity and heat efficiency	2.0	3.0	3.0	4.0	3.0	3.4
	% of composted digestate going to different destinations	2.0	1.0	1.0	2.0	2.0	1.8
	Type of soil where the digestate is applied: loam or sandy	5.0	1.0	1.0	5.0	4.0	4.0
Capital goods	3.0	3.0	1.0	2.0	2.0	2.6	
Transport	Types of trucks	4.0	1.0	2.5	1.0	2.0	2.9
	Distances	1.0	3.0	3.0	2.0	2.0	2.6
	Capital good of the trucks	3.0	2.0	1.0	2.0	2.0	2.4

Poland

Process	Data	Technological representativeness	Geographical representativeness	Time-related representativeness	Completeness	Reliability	DOR
HSW generation	HSW composition	1.5	1.0	2.0	4.0	3.0	3.1
	Chemical composition	1.0	1.0	3.0	1.0	1.0	2.1
Household sorting	HSW sorting efficiency	1.5	1.0	1.0	3.0	3.0	2.4
	Composition of the collected fractions	1.0	1.0	1.0	5.0	4.0	3.6
	Types of collection schemes	1.5	1.0	2.0	4.0	3.0	3.1
Collection	Fuel consumption	2.0	3.0	4.0	4.0	2.0	3.4
MRF	Sorting efficiencies	2.0	3.0	3.0	3.0	2.0	2.8
	Diesel consumption	2.0	3.0	2.0	1.0	1.0	2.3
	Electricity consumption	2.0	3.0	1.0	1.0	1.0	2.2
	Wire consumption	2.0	3.0	1.0	1.0	1.0	2.2
	Capital goods	5.0	2.0	1.0	4.0	2.0	3.8
Waste treatment	% of residual waste going to different treatments	1.5	1.0	2.0	2.0	2.0	1.8
	% of food waste going to different treatments	1.0	1.0	1.0	4.0	4.0	3.0
Recycling	Paper	1.8	1.0	2.0	2.3	2.5	2.2
	Cardboard	2.0	1.0	2.0	2.3	2.5	2.2
	Glass	1.8	2.2	2.4	2.6	2.4	2.4
	PET	1.8	1.0	2.3	2.8	2.0	2.3
	HDPE	1.8	1.0	2.3	2.8	1.8	2.3
	Soft Plastic	2.8	1.0	2.0	3.3	3.3	2.8
	Aluminium	1.8	1.9	2.3	2.5	1.8	2.2
Steel	2.3	1.8	2.2	2.7	2.4	2.5	
Landfill	Construction and operation	2.5	3.0	1.0	2.0	2.0	2.5
	Decay rates and order of degradation	2.0	3.0	2.0	3.0	2.0	2.7
	Weather conditions	1.0	1.0	1.0	1.0	1.0	1.0
	Gas Addition of trace substances (concentration of trace gasses in the landfill)	2.0	2.0	4.0	3.5	2.0	3.3

		Gas collection rate	2.0	1.0	1.5	4.0	3.0	3.1
		Gas utilization rate	2.0	1.0	1.5	3.0	3.0	2.5
		Types of gas utilization (electricity or heat)	2.0	1.0	1.5	4.0	3.5	3.1
		Emissions from different landfill gas treatment technologies	2.0	2.5	2.5	3.5	3.0	3.1
		Oxidation rates in the top covers	1.0	3.0	2.5	3.5	3.0	3.0
	Leachate	Net infiltration rate (leachate generation)	2.0	2.5	1.0	3.5	2.0	2.8
		Concentration of trace substances	2.0	2.5	2.5	3.5	2.5	3.0
		Collection efficiency	2.0	2.5	1.0	3.5	2.0	2.8
		Removal efficiencies	2.0	2.0	2.5	3.5	2.5	2.9
		Natural leachate attenuation rates	2.0	2.0	2.0	3.5	2.5	2.9
Mineral landfill	Leachate and emissions	2.5	3.0	1.0	4.0	3.0	3.3	
	Construction and operation	5.0	3.0	1.0	2.0	2.0	3.7	
MBP	Transfer coefficient	3.0	3.0	3.0	4.0	4.0	3.7	
	Energy consumption	3.0	3.0	3.0	4.0	4.0	3.7	
	Ancillary material consumption	3.0	3.0	3.0	4.0	4.0	3.7	
	Emissions to air and water	3.0	3.0	3.0	4.0	4.0	3.7	
	Capital goods	5.0	2.0	1.5	2.1	2.6	3.7	
Composting	Transfer coefficients	2.0	3.0	2.5	2.0	1.0	2.5	
	Energy consumption	2.0	3.0	3.0	2.0	1.0	2.6	
	Ancillary material consumption	2.0	3.0	3.0	2.0	1.0	2.6	
	Emissions to air and water	2.0	3.0	3.0	2.0	1.0	2.6	
	% of compost going to different destinations	2.0	1.0	1.0	2.0	2.0	1.8	
	Type of soil where the compost is applied: loam or sandy	5.0	1.0	1.0	5.0	4.0	4.0	
	Capital goods	3.0	3.0	1.0	1.0	2.0	2.4	
Transport	Types of trucks	4.0	1.0	2.5	1.0	2.0	2.9	
	Distances	1.0	3.0	3.0	2.0	2.0	2.6	
	Capital good of the trucks	3.0	2.0	1.0	2.0	2.0	2.4	

Greece

Process	Data	Technological representativeness	Geographical representativeness	Time-related representativeness	Completeness	Reliability	DQR
SW generation	HSW composition	1.5	2.0	2.5	4.0	3.0	3.2
	Chemical composition	1.5	1.0	3.0	1.0	1.0	2.2
Household sorting	HSW sorting efficiency	1.5	1.0	1.0	3.0	3.0	2.4
	Composition of the collected fractions	1.0	1.0	1.0	5.0	4.0	3.6
	Types of collection schemes	1.0	1.0	1.0	2.0	2.0	1.7
Collection	Fuel consumption	2.0	3.0	4.0	4.0	2.0	3.4
MRF	Sorting efficiencies	2.0	3.0	3.0	3.0	2.0	2.8
	Diesel consumption	2.0	3.0	2.0	1.0	1.0	2.3
	Electricity consumption	2.0	3.0	1.0	1.0	1.0	2.2
	Wire consumption	2.0	3.0	1.0	1.0	1.0	2.2
	Capital goods	5.0	2.0	1.0	4.0	2.0	3.8
Waste treatment	% of residual waste going to different treatments	1.5	1.0	2.0	3.0	3.0	2.5
Recycling	Paper	1.8	1.0	2.0	2.3	2.5	2.2
	Cardboard	2.0	1.0	2.0	2.3	2.5	2.2
	Glass	1.8	2.2	2.4	2.6	2.4	2.4
	PET	1.8	1.0	2.3	2.8	2.0	2.3
	HDPE	1.8	1.0	2.3	2.8	1.8	2.3
	Soft Plastic	2.8	1.0	2.0	3.3	3.3	2.8
	Al	1.8	1.9	2.3	2.5	1.8	2.2
	Steel	2.3	1.8	2.2	2.7	2.4	2.5
Mineral landfill	Leachate and emissions	2.5	3.0	1.0	4.0	3.0	3.3
	Construction and operation	5.0	3.0	1.0	2.0	2.0	3.7
Landfill	Construction and operation	2.5	3.0	1.0	2.0	2.0	2.5

		Decay rates and order of degradation	2.0	3.0	2.0	3.0	2.0	2.7
		Weather conditions	1.0	1.0	1.0	1.0	1.0	1.0
	Gas	Addition of trace substances	2.0	2.0	4.0	3.5	2.0	3.3
		Gas collection rate	2.0	1.0	1.5	4.0	3.5	3.1
		Gas utilization rate	2.0	1.0	1.5	3.0	3.5	2.8
		Types of gas utilization (electricity or heat)	2.0	1.0	1.5	4.0	3.5	3.1
		Emissions from different landfill gas treatment technologies	2.0	2.5	2.5	3.5	3.0	3.1
		Oxidation rates in the 3 types of top cover	1.0	3.0	2.5	3.5	3.0	3.0
	Leachate	Net infiltration rate (leachate generation)	2.0	2.5	1.0	3.5	2.0	2.8
		Concentration of trace substances	2.0	2.5	2.5	3.5	2.5	3.0
		Collection efficiency	2.0	2.5	1.0	3.5	2.0	2.8
		Removal efficiencies	2.0	2.0	2.5	3.5	2.5	2.9
		Natural leachate attenuation rates	2.0	2.0	2.0	3.5	2.5	2.9
	Transport	Types of trucks	4.0	1.0	2.5	1.0	2.0	2.9
Distances		1.0	3.0	3.0	2.0	2.0	2.6	
Capital good of the trucks		3.0	2.0	1.0	2.0	2.0	2.4	

3.12.2 Scoring of data quality for recycling processes

		Technological representativeness	Geographical representativeness	Time-related representativeness	Completeness	Reliability	DQR
Paper	Substitution ratio	1.0	1.0	3.0	2.0	2.0	2.3
	Substituted material	1.0	1.0	1.0	1.0	2.0	1.6
	Process	3.0	1.0	3.0	2.0	2.0	2.6
	Capital goods	2.0	1.0	1.0	4.0	4.0	3.1
	<i>Average</i>	1.8	1.0	2.0	2.3	2.5	2.2
Cardboard	Substitution ratio	1.0	1.0	3.0	2.0	2.0	2.3
	Substituted material	1.0	1.0	1.0	2.0	2.0	1.7
	Process	1.0	1.0	3.0	1.0	2.0	2.2
	Capital goods	5.0	1.0	1.0	4.0	4.0	3.9
	<i>Average</i>	2.0	1.0	2.0	2.3	2.5	2.2
Glass	Substitution ratio	1.0	1.0	3.0	2.0	2.0	2.3
	Substituted material	1.0	2.0	1.0	2.0	2.0	1.8
	Ancillary materials consumption	-	-	-	-	-	-
	Energy consumption	2.0	3.0	4.0	5.0	4.0	4.2
	Emissions to air	3.0	3.0	3.0	2.0	2.0	2.8
	Capital goods	2.0	2.0	1.0	2.0	2.0	1.9
	<i>Average</i>	1.8	2.2	2.4	2.6	2.4	2.4
PET	Substitution ratio	1.0	1.0	3.0	2.0	2.0	2.3
	Substituted material	1.0	1.0	1.0	1.0	2.0	1.6
	Ancillary materials consumption	-	-	-	-	-	-
	Energy consumption	2.0	1.0	4.0	4.0	2.0	3.2
	Emissions to air	-	-	-	-	-	-
	Capital goods	3.0	1.0	1.0	4.0	2.0	3.0
	<i>Average</i>	1.8	1.0	2.3	2.8	2.0	2.3
HDPE	Substitution ratio	1.0	1.0	3.0	2.0	2.0	2.3
	Substituted material	1.0	1.0	1.0	1.0	1.0	1.0
	Ancillary materials consumption	-	-	-	-	-	-
	Energy consumption	2.0	1.0	4.0	4.0	2.0	3.2
	Emissions to air	-	-	-	-	-	-
	Capital goods	3.0	1.0	1.0	4.0	2.0	3.0
	<i>Average</i>	1.8	1.0	2.3	2.8	1.8	2.3
Soft plastic	Substitution ratio	1.0	1.0	3.0	2.0	2.0	2.3
	Substituted material	5.0	1.0	1.0	2.0	2.0	3.4
	Ancillary materials consumption	-	-	-	-	-	-
	Energy consumption	2.0	1.0	3.0	4.0	5.0	3.9
	Emissions to air	-	-	-	-	-	-
	Capital goods	3.0	1.0	1.0	5.0	4.0	3.8
	<i>Average</i>	2.8	1.0	2.0	3.3	3.3	2.8
Aluminium	Substitution ratio	1.0	1.0	3.0	2.0	2.0	2.3
	Substituted material	1.0	1.0	1.0	3.0	2.0	2.2
	Ancillary materials consumption	-	-	-	-	-	-
	Energy consumption	2.0	3.0	2.0	3.0	1.0	2.6
	Emissions to air	3.0	2.5	3.0	2.0	2.0	2.7
	Capital goods	-	-	-	-	-	-
	<i>Average</i>	1.8	1.9	2.3	2.5	1.8	2.2
Steel	Substitution ratio	1.0	1.0	3.0	2.0	2.0	2.3
	Substituted material	1.5	1.0	1.0	1.0	2.0	1.6
	Ancillary materials consumption	-	-	-	-	-	-
	Energy consumption	2.0	2.0	3.0	3.5	2.0	2.9
	Emissions to air	3.0	2.0	3.0	2.0	2.0	2.7
	Capital goods	4.0	3.0	1.0	5.0	4.0	4.1
	<i>Average</i>	2.3	1.8	2.2	2.7	2.4	2.5

3.12.3 Scoring of data quality for each stage in each country

The data quality of each stage for the 5 indicators was calculated as the arithmetical average of the values for each parameter being part of the stage. The DQR was calculated as previously mentioned.

Germany						
	Technological representativeness	Geographical representativeness	Time-related representativeness	Completeness	Reliability	DQR
HSW generation	1.5	1.0	2.8	2.5	2.0	2.3
Household sorting	1.2	1.0	1.0	2.3	2.3	1.9
Collection	2.0	3.0	4.0	4.0	2.0	3.4
MRF	2.6	2.8	1.4	2.0	1.4	2.4
Waste treatment	1.5	1.0	1.0	1.0	2.0	1.6
Recycling	2.0	1.4	2.2	2.6	2.3	2.3
Landfill	-	-	-	-	-	0.0
Mineral landfill	3.8	3.0	1.0	3.0	2.5	3.1
WtE	1.8	2.4	1.9	2.7	1.6	2.4
MBT	3.4	1.3	2.6	3.7	3.6	3.3
Composting	2.6	2.4	2.1	2.3	1.7	2.4
AD	2.5	2.5	2.1	3.5	2.4	3.0
Transport	2.7	2.0	2.2	1.7	2.0	2.4
DENMARK						
	Technological representativeness	Geographical representativeness	Time-related representativeness	Completeness	Reliability	DQR
HSW generation	1.3	1.0	3.5	2.0	2.0	2.6
Household sorting	1.7	1.0	1.0	3.7	2.7	2.7
Collection	2.0	1.0	4.0	4.0	2.0	3.2
MRF	2.6	2.8	1.6	2.0	1.4	2.4
Waste treatment	3.0	1.0	1.0	3.0	2.0	2.4
Recycling	2.0	1.4	2.2	2.6	2.3	2.3
Landfill	-	-	-	-	-	-
Mineral landfill	3.8	1.5	1.0	3.0	2.5	3.0
WtE	2.0	1.3	1.9	3.0	1.9	2.4
MBT	-	-	-	-	-	-
Composting	-	-	-	-	-	-
AD	-	-	-	-	-	-
Transport	2.7	2.0	2.2	1.7	2.0	2.4
GREECE						
	Technological representativeness	Geographical representativeness	Time-related representativeness	Completeness	Reliability	DQR
HSW generation	1.5	1.5	2.8	2.5	2.0	2.4

Household sorting	1.2	1.0	1.0	3.3	3.0	2.5
Collection	2.0	3.0	4.0	4.0	2.0	3.4
MRF	2.6	2.8	1.6	2.0	1.4	2.4
Waste treatment	1.5	1.0	2.0	3.0	3.0	2.5
Recycling	2.0	1.4	2.2	2.6	2.3	2.3
Landfill	1.9	2.1	1.9	3.2	2.5	2.7
Mineral landfill	3.8	3.0	1.0	3.0	2.5	3.1
WtE	-	-	-	-	-	-
MBT	-	-	-	-	-	-
Composting	-	-	-	-	-	-
AD	-	-	-	-	-	-
Transport	2.7	2.0	2.2	1.7	2.0	2.4
France						
	Technological representativeness	Geographical representativeness	Time-related representativeness	Completeness	Reliability	DOR
HSW generation	1.3	1.0	2.5	1.0	1.3	1.9
Household sorting	1.5	1.0	2.0	1.0	1.7	1.7
Collection	2.0	3.0	4.0	4.0	2.0	3.4
MRF	2.6	2.8	1.6	2.0	1.4	2.4
Waste treatment	1.3	1.0	1.5	2.5	2.5	2.1
Recycling	2.0	1.4	2.2	2.6	2.3	2.3
Landfill	1.9	2.1	1.8	2.8	2.1	2.4
Mineral landfill	3.8	3.0	1.0	3.0	2.5	3.1
WtE	1.8	2.4	1.9	2.7	1.6	2.4
MBT	-	-	-	-	-	-
Composting	2.6	2.4	2.1	2.3	1.7	2.4
AD	2.6	2.5	1.9	2.1	1.6	2.3
Transport	2.7	2.0	2.2	1.7	2.0	2.4
Italy						
	Technological representativeness	Geographical representativeness	Time-related representativeness	Completeness	Reliability	DOR
HSW generation	1.3	1.0	2.3	2.5	2.0	2.1
Household sorting	1.3	1.0	1.3	3.0	3.0	2.4
Collection	2.0	3.0	4.0	4.0	2.0	3.4
MRF	2.2	2.6	1.6	2.0	1.4	2.2
Waste treatment	1.5	1.0	1.0	2.0	2.5	2.0
Recycling	2.0	1.4	2.2	2.6	2.3	2.3
Landfill	1.9	2.4	1.9	3.3	2.5	2.8
Mineral landfill	3.8	3.0	1.0	3.0	2.5	3.1
WtE	1.8	2.4	1.9	2.7	1.6	2.4
MBT	3.4	3.0	2.7	3.7	3.8	3.5
Composting	2.6	1.4	2.1	2.3	1.7	2.3
AD	2.5	2.5	2.1	3.5	2.4	3.0
Transport	2.7	2.0	2.2	1.7	2.0	2.4

Poland						
	Technological representativeness	Geographical representativeness	Time-related representativeness	Completeness	Reliability	DQR
HSW generation	1.3	1.0	2.5	2.5	2.0	2.1
Household sorting	1.3	1.0	1.3	4.0	3.3	3.0
Collection	2.0	3.0	4.0	4.0	2.0	3.4
MRF	2.6	2.8	1.6	2.0	1.4	2.4
Waste treatment	1.3	1.0	1.5	3.0	3.0	2.4
Recycling	2.0	1.4	2.2	2.6	2.3	2.3
Landfill	1.9	2.1	1.9	3.2	2.4	2.7
Mineral landfill	3.8	3.0	1.0	3.0	2.5	3.1
WtE	-	-	-	-	-	-
MBT	3.4	2.8	2.7	3.6	3.7	3.5
Composting	2.6	2.4	2.1	2.3	1.7	2.4
AD	-	-	-	-	-	-
Transport	2.7	2.0	2.2	1.7	2.0	2.4
UK						
	Technological representativeness	Geographical representativeness	Time-related representativeness	Completeness	Reliability	DQR
HSW generation	1.0	1.5	2.0	1.0	1.3	1.6
Household sorting	1.5	1.0	2.0	1.0	1.7	1.7
Collection	2.0	3.0	4.0	4.0	2.0	3.4
MRF	2.6	2.8	1.6	2.0	1.4	2.4
Waste treatment	1.5	1.0	1.0	1.5	2.0	1.7
Recycling	2.0	1.4	2.2	2.6	2.3	2.3
Landfill	1.9	2.1	1.8	2.8	2.1	2.4
Mineral landfill	3.8	3.0	1.0	3.0	2.5	3.1
WtE	1.8	2.4	1.9	3.0	1.6	2.5
MBT	-	-	-	-	-	-
Composting	2.6	2.4	2.1	2.3	1.7	2.4
AD	-	-	-	-	-	-
Transport	2.7	2.0	2.2	1.7	2.0	2.4

3.12.4 Conclusions on the data quality

The results of the Data Quality Rating (DQR) for each country can be resumed in Table 89. The data quality of each country for the 5 indicators was calculated as the arithmetical average of the values for each stage being part of the country. The average included the following stages and substages: HSW generation, Household sorting, Collection, MRF, Waste treatment, Recycling, Landfill, Mineral landfill, WtE, MBT, Composting, AD and Transport. The DQR was calculated as previously mentioned.

Table 89: Summary of data quality and DQR for each country

	Technological representativeness	Geographical representativeness	Time-related representativeness	Completeness	Reliability	DQR
DE	2.3	2.0	2.0	2.6	2.2	2.4
DK	2.3	1.4	2.0	2.8	2.1	2.4
FR	2.0	2.0	2.1	2.2	1.8	2.1
UK	2.1	2.1	2.0	2.3	1.9	2.1
IT	2.2	2.0	2.0	2.8	2.3	2.5
PL	2.2	2.0	2.1	2.9	2.4	2.6
EL	2.1	2.0	2.1	2.8	2.3	2.5

Few conclusions can be drawn based on the information showed in the previous tables:

- The majority of data regarding waste management systems have a basic quality due to lack of coherent data collected in different countries and because of the lack of national studies regarding specific processes as MBT or WtE.
- All the countries have similar DQRs, and the lowest is in France and UK due to the very detailed data found on waste composition, household waste sorting and fate of residuals.
- Regarding incineration plants, the parameters characterized by the lowest data quality are transfer coefficients, emissions to air and ancillary materials consumption. These data are characteristic on one Danish plant but their generalization is not supported by additional literature.
- Regarding landfill, the lowest data quality is seen in the gas emissions
- Very few data are available regarding AD plants
- The most uncertainty processes are waste collection, MBT and mineral landfill that are data estimate.

3.13 Sensitivity and scenario analysis

Sensitivity analysis is conducted to investigate sensitive inputs (Clavreul et al., 2012) and to analyse how much the assumptions made in the model inputs influence the results (Laurent et al., 2014). In this paper, the method described in Clavreul et al. (2012) is used. Due to the complexity of the system, the parameters that could be tested are countless. Therefore, the first step is to choose the parameters based on the processes that contribute the most to the results and on the uncertainty of the assumptions made.

3.13.1 Perturbation analysis

The perturbation analysis calculates the sensitivity ratio (SR) in order to observe the effect of a small variation of a parameter on the final results. SR is the ratio between the relative change of the result and the relative change of the parameter. The SR are calculated as:

$$SR = \frac{\frac{\Delta result}{initial\ result}}{\frac{\Delta parameter}{initial\ parameter}}$$

To compare different SRs in each country and in each impact category, the concept of the normalised sensitivity ratio (NSR) was developed and NSRs were calculated from each SR. NSR is defined as the ratio between the sensitivity ratio of one parameter in one impact category and the maximum absolute value among all the SRs in the same country in the same impact category:

$$NSR_i = \frac{SR_i}{\max(|SR_i|)}$$

Table 90 shows the parameters tested in the perturbation analysis. It has to be noted that the majority of the parameters were raised of 10% during the analysis (resulting in a denominator equal to 0.1), but few had to be lowered of 10% to avoid unrealistic scenarios (resulting in a denominator equal to -0.1), as a substitution ratio of glass higher than 1. These parameters were: substitution ratio of glass in the glass recycling process and all the transfer coefficients in the MBT plants. Finally, in the case of emissions from WtE, two different analyses were performed to obtain clearer results: the first step was to raise all the process specific and input specific emissions, and the second step was to focus on the substances that most contributed in the results: NO_x and SO_x in the process specific and CO₂, Hg and Cu in the input specific emissions.

Table 90: Parameters tested in the perturbation analysis and additional information to clarify some of the parameters

Process	Parameters tested	Additional information
Household sorting	Sorting efficiency food (+10%)	
	Sorting efficiency paper (+10%)	
	Sorting efficiency cardboard (+10%)	
	Sorting efficiency plastic bottles (+10%)	
	Sorting efficiency hard plastic (+10%)	
	Sorting efficiency soft plastic (+10%)	
	Sorting efficiency glass (+10%)	
	Sorting efficiency aluminium (+10%)	
	Sorting efficiency steel (+10%)	
Recycling	Substitution ratio paper (+10%)	
	Substitution ratio cardboard (+10%)	
	Substitution ratio PET (+10%)	
	Substitution ratio HDPE (+10%)	
	Substitution ratio soft plastic (+10%)	
	Substitution ratio glass (-10%)	
	Substitution ratio aluminium (+10%)	
	Substitution ratio steel (+10%)	
	Emissions paper (+10%)	All the substances emitted during the recycling processes
	Emissions glass (+10%)	
	Emissions aluminium (+10%)	
	Emissions steel (+10%)	
	Electricity consumption paper (+10%)	
Electricity consumption PET (+10%)		

	Electricity consumption HDPE (+10%)	
	Electricity consumption soft plastic (+10%)	
	Electricity consumption glass (+10%)	
	Electricity consumption aluminium (+10%)	
	Electricity consumption steel (+10%)	
	Heat consumption paper (+10%)	
	Heat consumption paper (+10%)	
	Heat consumption paper (+10%)	
	Heat consumption glass (+10%)	
	Heat consumption aluminium (+10%)	
	Ancillary material paper (+10%)	All the ancillary materials consumed
MBT	Transfer coefficient MBP_composting (-10%)	All the transfer coefficients of fractions going to MBP in the mechanical separation step
	Transfer coefficient MBP_RDF (-10%)	All the transfer coefficients of fractions going to RDF in the mechanical separation step
	Transfer coefficient MBP_Al (-10%)	Percentage of aluminium sorted in the mechanical separation step
	Transfer coefficient MBP_steel (-10%)	Percentage of steel sorted in the mechanical separation step
WtE	Ancillary material (+10%)	All the ancillary materials consumed
	Electricity recovery eff (+10%)	
	Heat recovery eff (+10%)	
	% Steel recovered (+10%)	Percentage of steel sorted in the WtE plant
	% Al recovered (+10%)	Percentage of aluminium sorted in the WtE plant
	Process specific emissions (+10%)	All the process specific emissions (e.g. CO ₂ , dioxins, HCl, HFI, NO _x , SO _x , particulates)
	NO _x in process specific (+10%)	
	SO ₂ in process specific (+10%)	
	Input specific emissions (+10%)	All the input specific emissions (e.g. Sb, Pb, Ni, Hg, Cu, Cr, Cd, S, Cl, C _{bio} , C _{fossil})
	CO ₂ fossil in input specific emissions (+10%)	
Hg in input specific emissions (+10%)		
Cu in input specific emissions (+10%)		
Landfill	Oxidation in top cover, daily (-10%)	All the substances emitted in the top covers
	Oxidation in top cover, intermediate (-10%)	
	Oxidation in top cover, final (-10%)	
	Gas collected (+10%)	
	Gas utilised (+10%)	
	Electrical efficiency of the gas collected (+10%)	
	Heat efficiency of the gas collected (+10%)	
	Infiltration rate (+10%)	The infiltration rate influences the quantity of leachate generated
C storage (+10%)		
Transport	Transport (+10%)	All the distances covered by the trucks

3.13.2 Scenario analysis

The scenario analysis simply "consists in testing different options individually and observing the effect of these changes on the final results." (Clavreul et al., 2012).

The following options were tested:

- Substitution of the substituted material in the paper recycling process from virgin to recycled paper. The process "paper production, newsprint, recycled, Europe" was based on ecoinventecoinvent database.
- Substitution of the capital good of landfills (both inert and normal) with the process found in Brogaard and Christensen 2016
- Substitution of the capital good of composting plants, AD plants, incineration plants and transport trucks with the process modelled in Brogaard and Christensen 2016

- Substitution of the type of soil where the compost and the composted digestate is applied from loam to sandy. Both the processes are based on EASETECH database

The following processes are included in the disposal phase of the processes based on Brogaard and Christensen 2016. As it can be seen, the main difference is the crediting of plastic, metals and concrete recycling:

- Composting plant
 - Building (steel) and (multi-storey) disposal processes from ecoinvent
 - plastic, steel, cable and concrete recycling – with crediting
- Anaerobic digestion plant
 - Building (steel) and (multi-storey) disposal processes from ecoinvent
 - plastic, steel, cable and concrete recycling – with crediting
- Incineration plant
 - Steel, cable and concrete recycling – with crediting
- Landfill
 - Steel, cable and concrete recycling – with crediting

Furthermore, seen the importance that the modelling of electricity and heat can have on the overall results, scenario analysis were performed on the electricity and heat consumed and substituted in each process. Each electricity and heat is a national average mix where several energy sources contribute (e.g. lignite, hard coal, natural gas, wind etc.). In each country, the “cleanest” and the “dirtiest” source among the all the sources contributing to the mix more than 5% were defined (Table 91 and Table 92). Since this LCA includes many impact categories, the processes that showed the best and the worst average environmental performance were chosen.

Table 91: Scenario analysis - electricity

	Process from ecoinvent showing average worst impacts	Process from ecoinvent showing average best impacts
DE	Electricity production, lignite [DE]	Electricity production, nuclear, pressure water reactor [DE]
DK	Heat and power co-generation, wood chips, 6667 kw, state-of-the-art 2014 [DK]	Electricity production, wind, <1MW turbine, onshore [DK]
FR	Electricity production, nuclear, pressure water reactor [FR]	Electricity production, hydro, run-of-river [FR]
UK	Electricity production, hard coal [UK]	Electricity production, nuclear, boiling water reactor [UK]
IT	Heat and power co-generation, oil [IT]	Electricity production, hydro, run-of-river [IT]
PL	Heat and power co-generation, lignite [PL]	Heat and power co-generation, wood chips, 6667 kw, state-of-the-art 2014 [PL]
EL	Heat and power co-generation, lignite [EL]	Electricity production, hydro, run-of-river [EL]

Table 92: Scenario analysis – heat. * The average Greek heat is composed of only one process, thus it was meaningless to perform a scenario analysis

	Process from ecoinvent showing average worst impacts	Process from ecoinvent showing average best impacts
DE	Heat, from municipal waste incineration to generic market for heat district or industrial, other than natural gas [DE]	Heat and power co-generation, natural gas, conventional power plant, 100MW electrical [DE]
DK	Heat, from municipal waste incineration to generic market for heat district or industrial, other than natural gas [DK]	Heat and power co-generation, natural gas, conventional power plant, 100MW electrical [DK]
FR	Heat, from municipal waste incineration to generic market for heat district or industrial, other than natural gas [FR]	Heat and power co-generation, natural gas, conventional power plant, 100MW electrical [FR]
UK	Treatment of coal gas, in power plant [UK]	Heat and power co-generation, natural gas, conventional power plant, 100MW electrical [UK]
IT	Heat and power co-generation, oil [IT]	Heat and power co-generation, natural gas, conventional power plant, 100MW electrical [IT]
PL	Heat and power co-generation, hard coal [PL]	Heat and power co-generation, natural gas, conventional power plant, 100MW electrical [PL]
EL	-*	-*

To quantify the results from the scenario analysis, the relative % between the results of the x scenario compared to the initial result was calculated: $Relative\ \% = \frac{|Results_{scenario}| - |Result_{baseline}|}{|Results_{baseline}|}$

4 Results

This chapter presents the general results of the LCA modelling. It is important to highlight that the results of an LCA should be analysed as potential environmental impacts, more than prediction of the actual effects (EC-JRC, 2010). As each impact category has its own unit, it is not possible to make any comparison to rank the impact categories on basis of the characterised results. Therefore, normalisation and weighting are necessary in order to compare different impact categories and different categories in the systems. A unitary weighting for all the impacts categories is always assumed in this paper.

Figure 14 and Figure 15 show the normalised results for the baseline scenario where the countries are listed according to the amount of landfilling as a percent of total waste management in 2013 as listed in European Commission (2014). The impact categories presented in this paper are divided in two groups: the first group includes the impacts categories commonly used in the LCA, Climate change, acidification and eutrophication; the second group includes Human (carcinogenic and non-) and Eco-Toxicity and Particular Matter and Depletion of abiotic resources (fossil and mineral).

Each colour represents a sum of processes and Table 93 explains how processes are grouped. To avoid confusion, the groups of processes are always mentioned with []. The contribution analysis of each group of processes is presented in the next paragraph.

Table 93: Description of how the processes are grouped

Group	What does it include
[Collection]	Waste collection, transport from households to the first treatment and capital goods of transport trucks
[Recycling]	MRF, transport of recyclable from the MRF to the recycling facilities, recycling facilities and capital goods of MRF, recycling facilities, transport trucks and material substitution.
[WtE]	WtE plant, bottom ash landfill, transport from WtE to bottom ash landfills and capital goods of WtE plant, bottom ash landfill of fly ash, transport trucks and substitution of energy
[WtE_Recycling]	Metals recycling facilities, transport from WtE to recycling facilities and capital goods of recycling facilities, transport trucks and material substitution from metals recovery
[MBT]	MBT plant, bottom ash landfills, transport from MBT to bottom ash landfills, bottom ash landfills, or to WtE plant, WtE plants, capital goods of all the facilities, transport trucks and substitution of energy (when present) from RDF combustion.
[MBT_Recycling]	Metals recycling facilities, transport from WtE to recycling facilities and capital goods of recycling facilities, transport trucks and material substitution from metals recovery
[Composting]	Composting facility, transport from the facility to the use on land, use on land of the compost and capital goods of the facility and of the trucks and substitution of chemical fertilizer (when present).
[AD]	AD and composting facilities, transport from the facility to the compost utilization, capital goods of facilities and trucks, substitution of energy from the combustion of biogas and substitution of chemical fertilizer due to the digestate application on soil
[Landfill]	Landfills, capital goods of landfills and substitution of energy from the combustion of collected gas (when present)

The graphs show the normalised results expressed in units of person-equivalents (PE) for each process and the net total value. The processes included in the waste management can represent both environmental loads (positive impacts) and savings (negative impacts). There are some quite considerable differences among countries and among impact categories but the trend of the countries in each category is similar, with few exceptions. Furthermore, it is interesting to notice that the order of magnitude is similar in all impact categories.

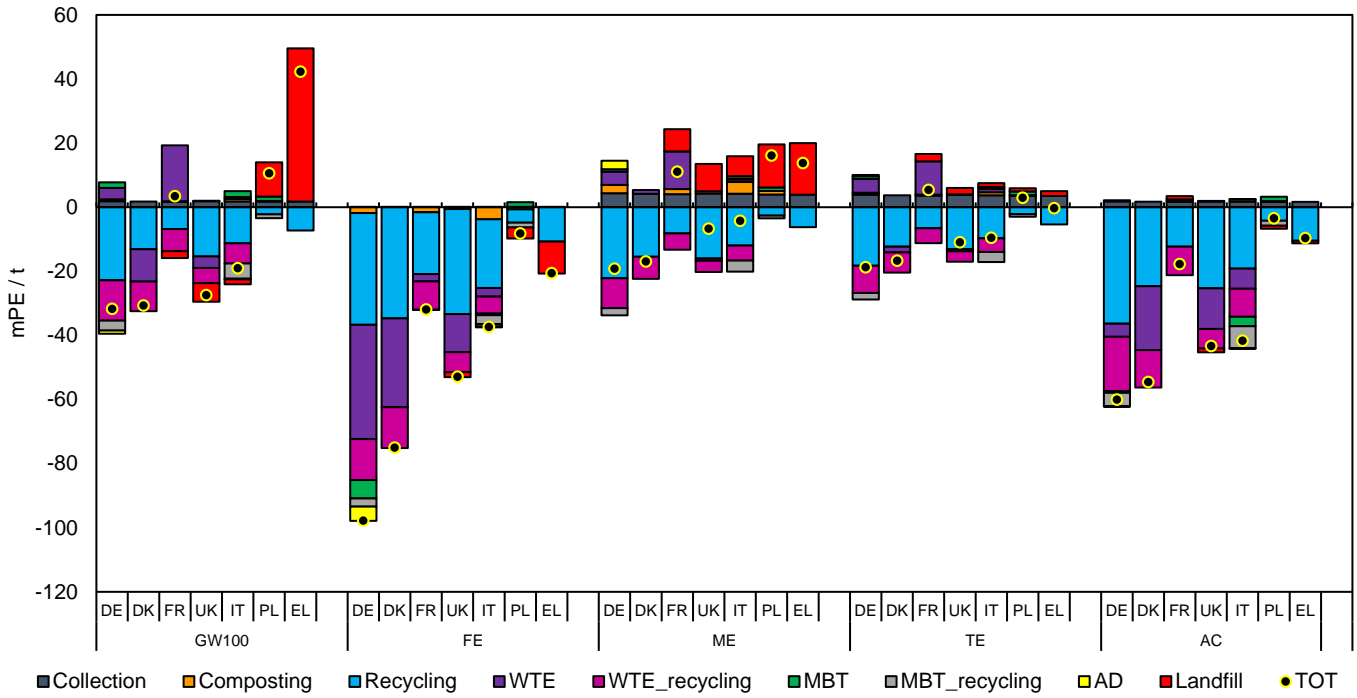

Figure 14: Normalised milli person-equivalent (mPE) per tonne for Climate Change (GP_{100}), Freshwater Eutrophication (FE), Marine Eutrophication (ME), Terrestrial Eutrophication (TE) and Terrestrial Acidification (AC). The countries studied are Germany (DE), Denmark (DK), France (FR), United Kingdom (UK), Italy (IT), Poland (PL) and Greece (EL)

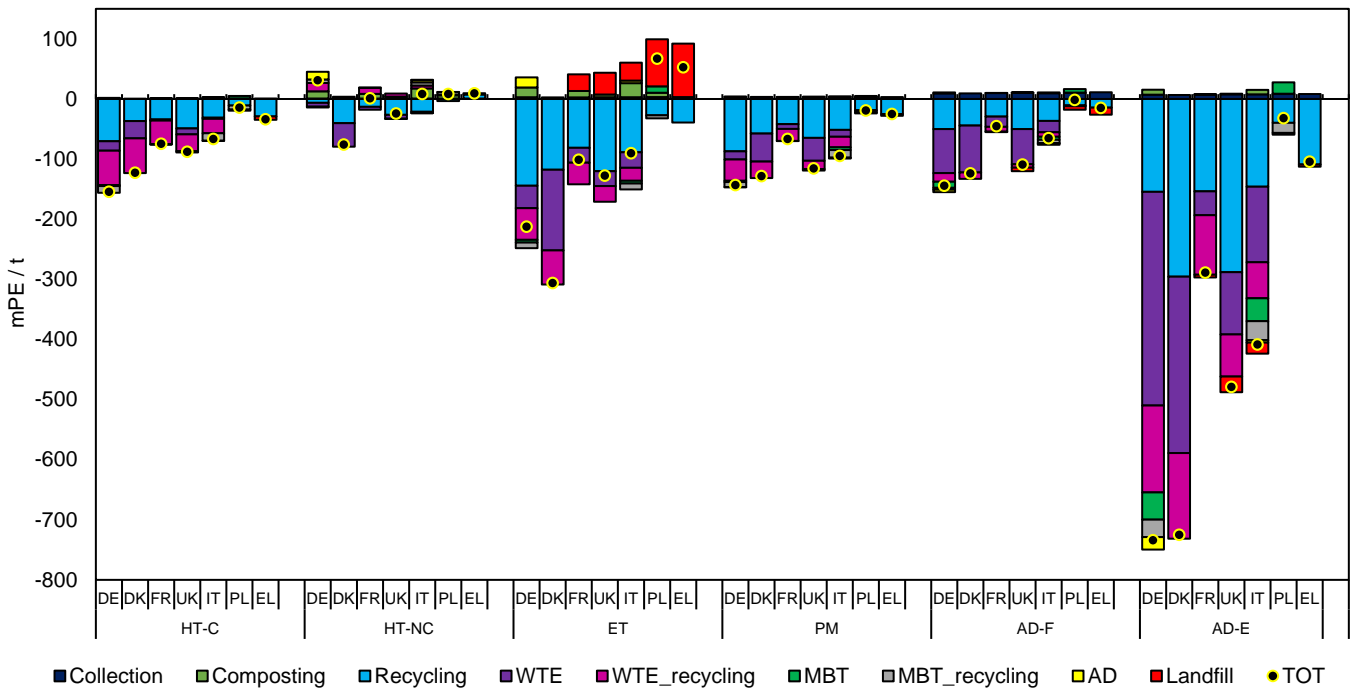

Figure 15: Normalised milli person-equivalent (mPE) per tonne for Human Toxicity, carcinogenic (HT-C), Human Toxicity, non-carcinogenic, (HT-NC), Freshwater eco-toxicity (ET) and Particular matter (PM), Depletion of Abiotic Fossil Resources (AD-F) and Depletion of Abiotic Mineral Resources (AD-E). The countries studied are Germany (DE), Denmark (DK), France (FR), United Kingdom (UK), Italy (IT), Poland (PL) and Greece (EL).

A clear contribution analysis of such a large system can be challenging, especially because it is in reality formed by 7 different independent systems correspondent to the 7 countries. Furthermore, it can be conducted on many different levels of detail. To avoid confusion and to present the results in the clearest way possible, a three steps method was developed. The first step was at the overall level, where the most contributing groups on the overall results were analysed. The second step was at the group level, where the processes inside each process were studied. The third step was a deep analysis of the processes themselves. Table 94, Table 95 and Table 96 show an example of such contribution analysis.

Table 94: example of contribution analysis – first level for the impact category Global Warming (GW100). The percentages are calculated over the sum of the absolute values in order to highlight both environmental impact and load

PE GW100							
	DE	DK	FR	UK	IT	PL	EL
Collection	1.87E-03	1.76E-03	1.75E-03	1.85E-03	1.82E-03	1.78E-03	1.77E-03
Composting	6.06E-04	-	1.33E-04	1.77E-04	7.69E-04	1.97E-04	-
Recycling	-2.28E-02	-1.31E-02	-6.84E-03	-1.54E-02	-1.13E-02	-2.24E-03	-7.27E-03
WTE	3.53E-03	-1.01E-02	1.74E-02	-3.59E-03	5.61E-04	-	-
WTE_recycling	-1.26E-02	-9.24E-03	-6.89E-03	-4.75E-03	-6.30E-03	-	-
MBT	1.76E-03	-	-	-	1.86E-03	1.36E-03	-
MBT_recycling	-3.07E-03	-	-	-	-4.74E-03	-1.19E-03	-
AD	-1.03E-03	-	-	-	-2.10E-04	0.00E+00	-
Landfill	-	-	-2.13E-03	-5.76E-03	-1.51E-03	1.07E-02	4.78E-02
TOT	-3.17E-02	-3.07E-02	3.44E-03	-2.74E-02	-1.90E-02	1.06E-02	4.23E-02
sum absolute values	4.73E-02	3.42E-02	3.51E-02	3.15E-02	2.90E-02	1.75E-02	5.68E-02
Percentages of contribution over the absolute values							
	DE	DK	FR	UK	IT	PL	EL
Collection	0.04	0.05	0.05	0.06	0.06	0.10	0.03
Composting	0.01	0.00	0.00	0.01	0.03	0.01	0.00
Recycling	0.48	0.38	0.19	0.49	0.39	0.13	0.13
WTE	0.07	0.29	0.50	0.11	0.02	0.00	0.00
WTE_recycling	0.27	0.27	0.20	0.15	0.22	0.00	0.00
MBT	0.04	0.00	0.00	0.00	0.06	0.08	0.00
MBT_recycling	0.06	0.00	0.00	0.00	0.16	0.07	0.00
AD	0.02	0.00	0.00	0.00	0.01	0.00	0.00
Landfill	0.00	0.00	0.06	0.18	0.05	0.61	0.84

Table 95: example of contribution analysis – second level for the group [WtE] in the impact category Global Warming (GW100). The percentages are calculated over the sum of the absolute values in order to highlight both environmental impact and load

PE GW100					
	DE	DK	FR	UK	IT
Incineration	3.28E-03 P	-1.05E-02	1.71E-02	-3.77E-03	4.35E-04
Transport	9.08E-06	9.57E-06	7.76E-06	4.10E-06	3.00E-06
Capital goods	2.32E-04	4.14E-04	2.80E-04	1.74E-04	1.19E-04
Bottom ash landfill	1.24E-05	1.21E-05	8.72E-06	5.49E-06	3.97E-06
TOT	3.53E-03	-1.01E-02	1.74E-02	-3.59E-03	5.61E-04
sum absolute values	3.53E-03	1.09E-02	1.74E-02	3.96E-03	5.61E-04
Contribution analysis – second level					
	DE	DK	FR	UK	IT
Incineration	93%	96%	98%	95%	78%
Transport	0%	0%	0%	0%	1%
Capital goods	7%	4%	2%	4%	21%
Bottom ash landfill	0%	0%	0%	0%	1%

Table 96: example of contribution analysis – third level for the process “Incineration” in the group [WtE] in the impact category Global Warming (GW100). The percentages are calculated over the sum of the absolute values in order to highlight both environmental impact and load

PE GW100					
	DE	DK	FR	UK	IT
Credited electricity	-1.46E-02	-1.66E-02	-1.94E-03	-1.23E-02	-3.25E-03
Credited heat	-1.25E-02	-2.50E-02	-6.67E-03	-1.11E-02	-6.49E-03
Emissions	2.96E-02	2.97E-02	2.48E-02	1.90E-02	9.81E-03
Ancillary materials	7.53E-04	1.39E-03	9.13E-04	5.80E-04	3.62E-04
TOT	3.29E-03	-1.05E-02	1.71E-02	-3.78E-03	4.35E-04
<i>sum absolute values</i>	5.75E-02	7.27E-02	3.43E-02	4.30E-02	1.99E-02
Contribution analysis – third level					
	DE	DK	FR	UK	IT
Credited electricity	25%	23%	6%	29%	16%
Credited heat	22%	34%	19%	26%	33%
Emissions	52%	41%	72%	44%	49%
Ancillary materials	1%	2%	3%	1%	2%

Some general observations on each country can be made:

- Germany shows the best environmental performance in almost all the impact categories due to the very high recycling rate and the low level of landfilling. The only exception is represented by *Human Toxicity, non-carcinogenic* due to the electricity consumption in steel recycling and in *Freshwater eco-toxicity* where Denmark is characterized by a very high saving due to heat substitution in the WtE plant. WtE is a relevant saving in few impact categories as *Freshwater Eutrophication*, *Depletion of Abiotic Fossil Resources* and *Depletion of Abiotic Mineral Resources* due to electricity substitution.
- The contribution of WtE plants in Denmark is very important in many of the impact categories because of the amount of waste incinerated and of the very efficient plants utilised. Denmark shows better savings than Germany in *Human Toxicity, non-carcinogenic* and *Freshwater eco-toxicity* as previously explained. Its performance is right after Germany in *Freshwater Eutrophication* due to the heat recovery and *Marine Eutrophication*. Finally, it is very similar to UK and Italy in *Climate Change*, *Terrestrial Eutrophication*, *Human Toxicity, non-carcinogenic*, *Particulate Matter* and *Depletion of Abiotic Fossil Resources*.
- Very peculiar is the results of WtE in France. Here the waste incinerated substitutes a “clean” electricity (made of 76% of nuclear and 10% of hydro) and relatively “clean” heat (made of 56% of natural gas). This explains the high environmental impact (or very low saving) that waste incineration has and the low overall environmental performance compared to countries with similar waste management as UK and Italy. The only exceptions at this statement are represented by *Human Toxicity, carcinogenic* and *Freshwater eco-toxicity* where the results of the three countries are similar.
- Regarding the countries with the lowest recycling rate as Poland and Greece, the latter shows often a better environmental performance than former although its recycling rate is much lower. This is caused by the higher quantity of metals recycled. At the contrary, *Climate Change* is much higher in Greece because of the methane emissions from the low performing landfills. No strong conclusion should be taken by this result because waste composition in both the countries is quite uncertain.

Following is a more detailed analysis of each groups.

[Collection]

[Collection] is important to be considered only in few impact categories as *Marine eutrophication* and *Terrestrial Eutrophication* in almost all the countries, *Human Toxicity, non-carcinogenic* in Greece and *Depletion of Abiotic Fossil Resources* in Greece and France. Impacts due to the collection of waste overtake impacts due to the transport of waste from households to the first treatments in *Marine eutrophication*, *Terrestrial Eutrophication*, while it is lower in the other impact categories.

[Composting] and [AD]

- Bio-waste treatment via composting and AD has a small net impact. The groups [Composting] and [AD] do not contribute relevantly to the results, even if no impurities were considered in the organic waste collected, thus the quality of the bio-products was probably higher than in reality. [Composting] causes a low load in *Eco-toxicity, total* in Italy due to Zn present in the compost, in *Human toxicity, non-carcinogenic* in Germany and France and medium in Italy and Poland due to Hg and Ni leaking during the use in agriculture. [Composting] is more important in Italy than in other countries due to the high quantity of food sent to composting. [AD] lowly contributes to the loads in *Marine eutrophication* in

Germany due to the heavy metals emissions (mainly Zn and Hg) that occurs during the use on land of composted digestate

- Analysing the group in more details, [Composting] represents an environmental load in all the impacts, but FE where phosphate substitution is the driving process. Transport is always negligible and capital goods shows a medium contribution only in *Human toxicity, carcinogenic*. The use of compost (mainly in agriculture) is the driving process in FE, *Marine eutrophication, Human toxicity, non-carcinogenic, Eco-toxicity, total* and the composting plant in GW100, *Terrestrial Eutrophication, Terrestrial Acidification, PM, Depletion Of Abiotic Fossil Resources* especially due to the electricity consumption and secondly to the emissions to air. *Depletion of Mineral Abiotic Resources* is influenced by capital goods and by the composting plants.

[Recycling], [WtE_Recycling] and [MBT_Recycling]

- Where recycling takes place, it mainly leads to savings (negative impacts), excluding *Human toxicity, non-carcinogenic* in Greece due to the air emissions caused by steel recycling. This means that the avoided production is generally more environmental friendly than the sum of emissions and electricity, heat and ancillary material consumptions. Furthermore, [Recycling] is the highest contributing group in most of the impact categories and of the countries. The recycling activities themselves are the most important processes in the group, and the magnitude of savings depends on the household waste composition and on the household sorting efficiency for each material. In general, paper shows from low to high contribution in all the impact categories in all the countries. Other significant materials are glass, aluminium (especially in GW100, *Marine eutrophication, Terrestrial Eutrophication, Terrestrial Acidification and Particulate Matter*) and steel (in *Freshwater Eutrophication, Human toxicity, carcinogenic, Human toxicity, non-carcinogenic* and *Eco-toxicity, total*). Less relevant, but still mentionable is PET in *Climate Change, Depletion of Abiotic Fossil Resources*. Aluminium seems not to be important in France because of the low percentage in the waste generated. The impacts caused by MRF, transport and bottom ash landfilling of residues are negligible. The capital goods display a medium contribution in *Depletion of Abiotic Mineral Resources* for all the countries but Greece mainly due to the capital goods of paper, cardboard, PET and glass. The capital goods show a low contribution in *Freshwater Eutrophication and Human toxicity, carcinogenic* in Poland mainly caused by the capital goods of glass and in *Human toxicity, non-carcinogenic* in Germany, Denmark and Poland due to the capital goods of paper, cardboard, PET and glass
- Analysing the recycling activities only, it appears that recycling almost always represents an environmental saving excluded few exceptions:
 - GW100 for soft plastic (due to electricity consumption in the remanufacturing process) and glass (due to the CO₂ emissions from the process-specific emissions and from the production of heat)
 - FE for HDPE and soft plastic (due to electricity consumption in the remanufacturing process) and aluminium (due to heat consumption in the remanufacturing process)
 - *Human toxicity, carcinogenic* for cardboard
 - *Human toxicity, non-carcinogenic* for HDPE and steel (due to electricity consumption in the remanufacturing process).
 - *Depletion of Abiotic Mineral Resources* for cardboard and HDPE (due to electricity consumption in the remanufacturing process)
- Very important are also [WtE_Recycling] and [MBT_Recycling] for the countries that utilise these technologies. Recycling of metals from WtE and MBT plants is equally or more important than energy recovery for many of the impacts in all the countries excluding Denmark. The same considerations can be made for both of them because of their similarity. Capital goods and transport are negligible in all the impact categories. In addition, recycling of aluminium is prevalent in *Climate Change, Marine eutrophication, Terrestrial Eutrophication, Terrestrial Acidification, Particulate Matter, Depletion of Abiotic Fossil Resources*, while recycling of steel is predominant in *Freshwater Eutrophication, Human toxicity, carcinogenic, Human toxicity, non-carcinogenic, Eco-toxicity, total* and *Depletion of Abiotic Mineral Resources*.

[WtE]

- [WtE] contribution to the overall result generally ranges from medium to low and it is particularly relevant in Denmark due to its high thermal average efficiencies caused by a developed district heating system and by the composition of the electricity and heat substituted. Since the incineration activity is the most important process in the group, this is the one determining if the group represents an environmental saving or an environmental load. Incineration can be negative or positive depending on several parameters, as composition of the electricity and of the heat substituted, thermal efficiency of the plants, composition of the entering material (for the input-specific emissions) and quantity of the waste

incinerated in the country (for the process-specific emissions). Capital goods is relatively important mainly in *Human toxicity, carcinogenic*.

- Analysing the incineration process, the following observations can be made. Ancillary materials consumption is always negligible. The process generally represents an environmental saving a part for specific cases described as following. CO₂ input specific emissions are responsible of the environmental load in GW₁₀₀ in Germany, France and Italy, while NO_x process specific emissions cause a positive impact in *Marine eutrophication* and *Terrestrial Eutrophication* in Germany, France and Italy and *Terrestrial Acidification* in France. [WtE] in Denmark has an overall positive impact only in *Marine eutrophication*.

[Landfill]

- Landfill is central in GW₁₀₀ for Greece and Poland and in *Marine eutrophication* and *Eco-toxicity, total* for all the countries that have landfilling of bio-waste (FR, UK, IT, PL and EL). GW₁₀₀ is due to methane emissions, while *Marine eutrophication* and *Eco-toxicity, total* are caused by the discharge of ammonium and zinc from the leachate treatment to the surface water, respectively. Carbon sequestration is a fundamental parameter in the GW₁₀₀ impact category because it balances the GHG emissions from the landfilling neutralizing them. It has to be noted that the negative impact for landfilling in FE is due to the anaerobic digestion of primary and secondary sludge from landfills.

[MBT]

- [MBT] does not contribute to the overall results in Germany and Italy and it contributes minimally to Poland. MBT plant consumption and the incineration of RDF seem to be negligible. For this reason and because it is not the focus of this paper, the assumption of modelling the plant for RDF as WtE is considered acceptable.

A separate discussion is added for waste transport, and capital goods.

Waste transport has a relevant influence on *Human toxicity, non-carcinogenic* in all the countries due to the emissions of Zinc, while in the other impact categories is negligible. The main responsible processes are transport of the collection trucks and transport of the recyclables. The share of these two processes depends on the percentage of recyclable collected. In fact, transport from MRF to recycling plants is responsible for over 60% of the transport impacts in Germany, Denmark and Italy, while transport of the collection trucks is more important in the Poland and Greece.

Capital goods, mainly of the recycling activities, are very important for all the countries for the impact category *Depletion of Abiotic Mineral Resources*, which is due to ores extracted (Indium, Nickel, Tantalum, Cadmium, etc.). Also in this impact category, capital goods impacts are fully offset by the recovery of recycled material and energy. Poland, and to a lesser extent Greece, show a much more important contribution in many of the impact categories caused by recycling and landfilling processes. This is due to two reasons: the quantity of waste sent to landfilling is much higher, and the material or energy recovery is too little compared to the other countries.

4.1 Characterized results

4.1.1 Germany

	GW100	FE	ME	TE	AC	HT-C	HT-NC	ET	PM	AD-F	AD-E
	kg CO2- eq./year	kg P- eq./year	kg N- eq./year	AE/year	AE/year	CTUh /year	CTUh/year	CTUe/year	kg PM 2.5/year	MJ/year	kg Sb- eq./year
Collection	1.51E+01	7.34E-05	4.12E-02	4.51E-01	9.04E-02	3.79E-08	8.40E-07	1.87E+00	9.71E-03	5.88E+02	2.48E-04
Composting	4.91E+00	-1.13E-03	2.40E-02	7.11E-02	1.79E-02	4.96E-08	1.31E-05	1.10E+01	1.10E-03	8.83E+01	2.86E-04
Recycling	-1.85E+02	-2.16E-02	-2.08E-01	-2.10E+00	-1.80E+00	-3.81E-06	-7.06E-06	-9.60E+01	-2.40E-01	-3.13E+03	-5.30E-03
WTE	2.86E+01	-2.21E-02	3.91E-02	4.92E-01	-2.03E-01	-8.52E-07	-7.07E-06	-2.48E+01	-3.74E-02	-4.56E+03	-1.22E-02
WTE_recycling	-1.02E+02	-7.93E-03	-8.76E-02	-9.74E-01	-8.39E-01	-3.10E-06	1.55E-05	-3.51E+01	-9.82E-02	-9.05E+02	-4.96E-03
MBT	1.43E+01	-3.55E-03	6.80E-03	9.66E-02	-2.83E-02	-8.38E-08	-1.28E-06	-2.86E+00	-5.44E-03	-6.23E+02	-1.55E-03
MBT_recycling	-2.49E+01	-1.59E-03	-2.11E-02	-2.33E-01	-2.09E-01	-6.13E-07	6.20E-06	-6.27E+00	-2.33E-02	-2.13E+02	-1.00E-03
AD	-8.32E+00	-2.76E-03	2.50E-02	4.69E-02	-4.03E-03	1.64E-08	1.42E-05	1.10E+01	-1.19E-03	-2.39E+02	-7.11E-04
Landfill	-	-	-	-	-	-	-	-	-	-	-
TOT	-2.57E+02	-6.06E-02	-1.80E-01	-2.15E+00	-2.98E+00	-8.36E-06	3.44E-05	-1.41E+02	-3.95E-01	-8.99E+03	-2.52E-02

4.1.2 Denmark

	GW100	FE	ME	TE	AC	HT-C	HT-NC	ET	PM	AD-F	AD-E
	kg CO2- eq./year	kg P- eq./year	kg N- eq./year	AE/year	AE/year	CTUh /year	CTUh/year	CTUe/year	kg PM 2.5/year	MJ/year	kg Sb- eq./year
Collection	1.43E+01	6.75E-05	3.90E-02	4.27E-01	8.56E-02	3.49E-08	7.74E-07	1.72E+00	9.23E-03	5.85E+02	2.28E-04
COMPOSTING	-	-	-	-	-	-	-	-	-	-	-
Recycling	-1.06E+02	-2.15E-02	-1.45E-01	-1.42E+00	-1.22E+00	-1.99E-06	-4.43E-05	-7.82E+01	-1.59E-01	-2.76E+03	-1.01E-02
WTE	-8.15E+01	-1.72E-02	1.15E-02	-2.07E-01	-9.87E-01	-1.57E-06	-4.31E-05	-8.93E+01	-1.29E-01	-4.87E+03	-1.01E-02
WTE_recycling	-7.48E+01	-7.88E-03	-6.43E-02	-7.20E-01	-5.80E-01	-3.12E-06	3.21E-06	-3.77E+01	-7.54E-02	-6.76E+02	-4.89E-03
MBT	-	-	-	-	-	-	-	-	-	-	-
MBT_recycling	-	-	-	-	-	-	-	-	-	-	-
AD	-	-	-	-	-	-	-	-	-	-	-
Landfill	-	-	-	-	-	-	-	-	-	-	-
TOT	-2.48E+02	-4.65E-02	-1.59E-01	-1.92E+00	-2.71E+00	-6.64E-06	-8.35E-05	-2.03E+02	-3.54E-01	-7.71E+03	-2.49E-02

4.1.3 France

	GW100	FE	ME	TE	AC	HT-C	HT-NC	ET	PM	AD-F	AD-E
	kg CO2- eq./year	kg P- eq./year	kg N- eq./year	AE/year	AE/year	CTUh /year	CTUh/yea r	CTUe/yea r	kg PM 2.5/year	MJ/year	kg Sb- eq./year
Collection	1.42E+01	7.25E-05	3.82E-02	4.18E-01	8.42E-02	3.75E-08	8.27E-07	1.83E+00	8.99E-03	6.16E+02	2.44E-04
COMPOSTING	1.08E+00	-9.82E-04	1.49E-02	3.22E-02	7.59E-03	2.16E-08	8.51E-06	7.05E+00	4.58E-04	1.29E+01	2.84E-05
Recycling	-5.53E+01	-1.19E-02	-7.66E-02	-7.55E-01	-6.11E-01	-1.85E-06	-1.43E-05	-5.40E+01	-1.15E-01	-1.83E+03	-5.27E-03
WTE	1.41E+02	-1.43E-03	1.10E-01	1.20E+00	2.94E-02	-9.75E-08	-5.37E-06	-1.64E+01	-2.22E-02	-1.07E+03	-1.36E-03
WTE_recycling	-5.58E+01	-5.49E-03	-4.79E-02	-5.35E-01	-4.40E-01	-2.14E-06	1.10E-05	-2.39E+01	-5.54E-02	-4.93E+02	-3.40E-03
MBT	-	-	-	-	-	-	-	-	-	-	-
MBT_recycling	-	-	-	-	-	-	-	-	-	-	-
AD	-	-	-	-	-	-	-	-	-	-	-
Landfill	-1.72E+01	-2.40E-05	6.51E-02	2.63E-01	5.02E-02	-5.88E-11	6.27E-07	1.83E+01	-1.71E-04	-4.59E+01	-1.51E-04
TOT	2.79E+01	-1.98E-02	1.04E-01	6.19E-01	-8.80E-01	-4.03E-06	1.35E-06	-6.72E+01	-1.84E-01	-2.81E+03	-9.91E-03

4.1.4 UK

	GW100	FE	ME	TE	AC	HT-C	HT-NC	ET	PM	AD-F	AD-E
	kg CO2- eq./year	kg P- eq./year	kg N- eq./year	AE/year	AE/year	CTUh /year	CTUh/year	CTUe/year	kg PM 2.5/year	MJ/year	kg Sb- eq./year
Collection	1.50E+01	7.94E-05	4.00E-02	4.38E-01	8.83E-02	4.10E-08	9.01E-07	1.99E+00	9.40E-03	6.67E+02	2.65E-04
COMPOSTING	1.43E+00	-3.46E-04	6.75E-03	2.45E-02	9.09E-03	1.55E-08	3.53E-06	3.01E+00	5.05E-04	1.84E+01	3.77E-05
Recycling	-1.24E+02	-2.03E-02	-1.50E-01	-1.50E+00	-1.25E+00	-2.66E-06	-2.91E-05	-7.98E+01	-1.78E-01	-3.12E+03	-9.88E-03
WTE	-2.91E+01	-7.38E-03	-6.53E-03	-8.34E-02	-6.31E-01	-5.34E-07	-6.78E-06	-1.65E+01	-1.05E-01	-3.66E+03	-3.56E-03
WTE_recycling	-3.85E+01	-3.87E-03	-3.30E-02	-3.69E-01	-3.02E-01	-1.52E-06	5.60E-06	-1.75E+01	-3.84E-02	-3.42E+02	-2.40E-03
MBT	-	-	-	-	-	-	-	-	-	-	-
MBT_recycling	-	-	-	-	-	-	-	-	-	-	-
AD	-	-	-	-	-	-	-	-	-	-	-
Landfill	-4.66E+01	-9.52E-04	7.99E-02	2.32E-01	-5.94E-02	-1.07E-07	-7.24E-07	2.40E+01	-6.63E-03	-3.71E+02	-8.96E-04
TOT	-2.22E+02	-3.28E-02	-6.28E-02	-1.26E+00	-2.15E+00	-4.76E-06	-2.66E-05	-8.47E+01	-3.19E-01	-6.81E+03	-1.64E-02

4.1.5 Italy

	GW100	FE	ME	TE	AC	HT-C	HT-NC	ET	PM	AD-F	AD-E
	kg CO2- eq./year	kg P- eq./year	kg N- eq./year	AE/year	AE/year	CTUh /year	CTUh/yea r	CTUe/yea r	kg PM 2.5/year	MJ/year	kg Sb- eq./year
Collection	1.47E+01	7.82E-05	3.94E-02	4.30E-01	8.67E-02	4.04E-08	8.88E-07	1.96E+00	9.23E-03	5.95E+02	2.63E-04
COMPOSTING	6.23E+00	-2.34E-03	3.44E-02	1.09E-01	3.63E-02	6.15E-08	1.83E-05	1.56E+01	2.35E-03	8.22E+01	2.61E-04
Recycling	-9.12E+01	-1.33E-02	-1.12E-01	-1.12E+00	-9.51E-01	-1.69E-06	-2.35E-05	-5.90E+01	-1.42E-01	-2.27E+03	-5.01E-03
WTE	4.54E+00	-1.67E-03	7.58E-03	1.10E-01	-3.10E-01	-1.03E-07	-2.20E-06	-1.71E+01	-3.16E-02	-1.19E+03	-4.31E-03
WTE_recycling	-5.10E+01	-3.28E-03	-4.38E-02	-4.85E-01	-4.35E-01	-1.29E-06	5.53E-06	-1.44E+01	-4.82E-02	-4.53E+02	-2.05E-03
MBT	1.51E+01	-2.94E-04	3.38E-03	7.01E-02	-1.47E-01	4.51E-08	-3.15E-07	-2.94E+00	-1.27E-02	-3.28E+02	-1.30E-03
MBT_recycling	-3.84E+01	-1.72E-03	-3.26E-02	-3.59E-01	-3.39E-01	-6.73E-07	5.89E-06	-6.63E+00	-3.51E-02	-3.33E+02	-1.09E-03
AD	-1.70E+00	-4.53E-04	6.26E-03	6.49E-03	-9.36E-03	1.28E-08	3.91E-06	2.78E+00	-8.94E-04	-3.68E+01	-1.38E-04
Landfill	-1.23E+01	-1.80E-04	5.80E-02	1.39E-01	2.44E-03	-2.66E-09	7.64E-07	1.99E+01	-2.53E-03	-1.34E+02	-6.29E-04
TOT	-1.54E+02	-2.31E-02	-3.98E-02	-1.10E+00	-2.06E+00	-3.60E-06	9.21E-06	-5.99E+01	-2.62E-01	-4.07E+03	-1.40E-02

4.1.6 Poland

	GW100	FE	ME	TE	AC	HT-C	HT-NC	ET	PM	AD-F	AD-E
	kg CO2- eq./year	kg P- eq./year	kg N- eq./year	AE/year	AE/year	CTUh /year	CTUh/year	CTUe/year	kg PM 2.5/year	MJ/year	kg Sb- eq./year
Collection	1.44E+01	8.60E-05	3.72E-02	4.07E-01	8.26E-02	4.45E-08	9.67E-07	2.11E+00	8.65E-03	6.36E+02	2.85E-04
COMPOSTING	1.60E+00	-4.12E-04	1.03E-02	2.50E-02	1.17E-02	2.01E-08	5.71E-06	4.72E+00	6.73E-04	3.21E+01	1.48E-05
Recycling	-1.81E+01	-2.58E-03	-2.44E-02	-2.50E-01	-2.10E-01	-5.96E-07	-3.71E-06	-1.80E+01	-5.18E-02	-6.69E+02	-1.36E-03
WTE	-	-	-	-	-	-	-	-	-	-	-
WTE_recycling	-	-	-	-	-	-	-	-	-	-	-
MBT	1.10E+01	8.97E-04	1.01E-02	1.32E-01	6.70E-02	2.10E-07	1.35E-06	7.15E+00	4.27E-03	3.58E+02	6.46E-04
MBT_recycling	-9.64E+00	-9.31E-04	-8.06E-03	-9.00E-02	-7.55E-02	-3.52E-07	4.46E-06	-3.35E+00	-9.43E-03	-7.94E+01	-5.71E-04
AD	-	-	-	-	-	-	-	-	-	-	-
Landfill	8.66E+01	-2.14E-03	1.26E-01	1.16E-01	-4.63E-02	-9.85E-08	5.27E-07	5.20E+01	-5.07E-03	-3.72E+02	-1.05E-04
TOT	8.58E+01	-5.08E-03	1.51E-01	3.39E-01	-1.71E-01	-7.73E-07	9.31E-06	4.47E+01	-5.27E-02	-9.48E+01	-1.09E-03

4.1.7 Greece

	GW100	FE	ME	TE	AC	HT-C	HT-NC	ET	PM	AD-F	AD-E
	kg CO2- eq./year	kg P- eq./year	kg N- eq./year	AE/year	AE/year	CTUh /year	CTUh/yea r	CTUe/yea r	kg PM 2.5/year	MJ/year	kg Sb- eq./year
Collection	1.43E+01	8.68E-05	3.69E-02	4.04E-01	8.21E-02	4.49E-08	9.75E-07	2.13E+00	8.60E-03	7.05E+02	2.86E-04
COMPOSTING	0.00E+00	0.00E+00	0.00E+00	0.00E+00	0.00E+00	0.00E+00	0.00E+00	0.00E+00	0.00E+00	0.00E+00	0.00E+00
Recycling	-5.88E+01	-6.65E-03	-5.82E-02	-6.16E-01	-5.18E-01	-1.57E-06	7.31E-06	-2.61E+01	-6.88E-02	-9.02E+02	-3.74E-03
WTE	-	-	-	-	-	-	-	-	-	-	-
WTE_recycling	-	-	-	-	-	-	-	-	-	-	-
MBT	-	-	-	-	-	-	-	-	-	-	-
MBT_recycling	-	-	-	-	-	-	-	-	-	-	-
AD	-	-	-	-	-	-	-	-	-	-	-
Landfill	3.87E+02	-6.20E-03	1.51E-01	1.74E-01	-4.17E-02	-3.06E-07	2.16E-06	5.92E+01	-8.56E-03	-7.22E+02	-1.21E-04
TOT	3.42E+02	-1.28E-02	1.29E-01	-3.73E-02	-4.77E-01	-1.83E-06	1.04E-05	3.52E+01	-6.88E-02	-9.19E+02	-3.57E-03

5 Discussion

5.1 Sensitivity scenario

5.1.1 Perturbation analysis

The perturbation analysis was conducted by calculating the normalised sensitivity ratio (NSR) in order to highlight the parameters the model is more sensitive of. NSR is defines as:

$$NSR_i = \frac{SR_i}{\max\{|SR_i|\}} \quad , \text{where } SR = \frac{\frac{\Delta \text{result}}{\text{initial result}}}{\frac{\Delta \text{parameter}}{\text{initial parameter}}}$$

Most of the parameters described in the LCI are raised of 10%, apart for few that were lowered of 10% to avoid impossible situations.

Following this paragraph are the NSRs for all the parameters in each country. All the NSRs are positive because they are based on absolute values. To simplify the interpretation of the perturbation analysis, colours were chosen in order to define when the parameters showed a medium, high and very high sensitivity (Table 97).

Table 97: Scale of colour to interpret the normalised sensitivity ratio (NSRs) in the following paragraphs

Negligible	NSR < 0.1
Low	0.1 < NSR < 0.5
Medium	0.5 < NSR < 0.8
High	0.8 < NSR < 0.9
Very high	NSR > 0.9
0-00	By increasing/decreasing the parameter, no change was observed in the results. It includes the parameters that are not present in one specific country.

Generally, paper, and to a lesser extent metals and glass, are the most influencing materials of the model when considering substitution ratio and in a lower degree household sorting efficiencies. Emissions from steel reprocessing highly influence *Human toxicity, non-carcinogenic* mainly due to the heavy metals Cd and Zn. Other very significant parameters are emissions from incineration plants (CO₂ for GW100 and NO_x for *Marine eutrophication* and *Terrestrial Eutrophication*) in the countries that use this technology and gas collection rates for GW100 and infiltration rate of landfills for *Eco-toxicity, total* in France, UK and Italy. Due to the higher percentage of waste landfilled in Poland and Greece, more parameters of landfilling are to be considered as oxidation rates of covers and C storage in *Climate Change*, gas utilisation rate in many impact categories, and infiltration rate in *Marine eutrophication* and *Eco-toxicity, total*. In addition, C storage is very significant in Italy in *Climate Change*. A little less significant are energy efficiencies in WtE plants (especially for Denmark) and metals recovery that improve the environmental performance when raised. Little significant but not negligible are the emissions from paper and glass reprocessing and substitution ratio of cardboard for Germany and Italy. The model is not very sensitive to MBT parameters and by raising the transport distances mainly impact only the results in *Depletion of Abiotic Fossil Resources*.

A more detailed summary of the perturbation analysis is hereby described:

- Observing the results of the sensitivity analysis respect the household efficiencies of sorting, it is complex to indicate a homogenous pattern in all the countries because household sorting efficiencies affects all the processes of the system and it depends on the technologies used. In general, increasing sorting efficiencies of paper and hard plastic, glass and metals led to a general better environmental performance excluded the very few impact categories where these materials where performing as a load. More inconsistent are the recycling of soft plastic and cardboard and food. Regarding the NSRs sorting of paper show an important perturbation analysis in Italy, France, UK and a little bit less relevant in Denmark, Greece and Poland. Following the same conclusion as in the contribution analysis, Greece is highly dependent on the sorting efficiency of metals because its savings derive mainly from metals recycling.
- By raising the substitution ratios in the recycling processes, a better environmental performance was seen, while by lifting up the energy consumption and the emissions it was worst. The parameters generally most sensitive are the substitution ratios of paper and metals. Lower but still mentionable NSR are the substitution ratio of glass. These considerations are valid for all the countries but Poland where glass has the highest sensitivity, mostly because of the low total percentage of paper and metals recycled. The substances emitted during the recycling process of steel are of great concern in *Human toxicity, non-carcinogenic* in all the countries but Denmark, mainly due to the heavy metals Cadmium and Zinc. The

substitution ratio of cardboard is surprisingly important for all the country in *Depletion of Abiotic Mineral Resources*.

- Even if the transfer coefficients of the MBTs utilised in Germany, Italy and Poland are affected by great uncertainty, the model is not sensitive to their small variation. Only in Poland the recycling rate of steel in Poland for the human toxicity categories show a medium NSR. In fact, in this country no incineration of the RDF is present and MBT impacts are mainly driven by the recycling processes.
- All the countries that include waste incineration in their waste systems are affected by energy efficiencies and even more by the emissions. Raising energy recovery efficiency and metals recycling in the WtE plants leads to a general better performance. In particular, NOx emissions modelled as process specific significantly worsen the results of *Marine eutrophication* and *Terrestrial Eutrophication* in all the countries and *Terrestrial Acidification* only in France, while the emission of fossil CO2 worsen GW100. Finally, the relative importance of electricity and heat efficiency vary depending on the country and they are generally more relevant in Denmark and Italy.
- The perturbation of the parameters of landfilling modelling strongly depend on the quantity of waste treated by disposal man. In France, Italy and UK, the only two impact categories that show a NSR at least medium are *Climate Change* and *Eco-toxicity, total*, influenced by the gas collection rate and the infiltration rate, respectively. The infiltration rate is directly proportionate to the leachate generation. Furthermore, in Italy, C storage affects *Climate Change* as well. On the other hand, In Poland and Greece parameters of landfilling are much more important: oxidation rates and Cstorage show important NSR in *Climate Change*, gas utilisation rate in many impact categories, and infiltration rate in *Marine eutrophication* and *Eco-toxicity, total*.
- Raising the transport distances mainly impact only the results in *Depletion of Abiotic Fossil Resources*.

5.1.1.1 Germany

		GW 100	FE	ME	TE	AC	HT-C	HT- NC	ET	PM	AD-F	AD-E
Household sorting	Sorting efficiency food	0.01	0.20	0.32	0.09	0.01	0.01	0.38	0.27	0.01	0.03	0.02
	Sorting efficiency paper	0.19	0.73	0.43	0.38	0.34	0.13	0.47	0.49	0.38	0.49	0.46
	Sorting efficiency cardboard	0.01	0.01	0.05	0.00	0.00	0.02	0.01	0.16	0.03	0.10	0.45
	Sorting efficiency plastic bottles	0.00	0.00	0.00	0.00	0.00	0.00	0.00	0.00	0.00	0.00	0.00
	Sorting efficiency hard plastic	0.06	0.01	0.06	0.06	0.04	0.02	0.00	0.03	0.07	0.16	0.01
	Sorting efficiency soft plastic	0.01	0.01	0.02	0.01	0.01	0.00	0.00	0.02	0.03	0.04	0.01
	Sorting efficiency glass	0.02	0.02	0.00	0.00	0.03	0.05	0.04	0.14	0.26	0.06	0.05
	Sorting efficiency aluminium	0.33	0.01	0.48	0.48	0.49	0.00	0.07	0.03	0.50	0.26	0.01
	Sorting efficiency steel	0.08	0.36	0.11	0.12	0.06	0.40	0.50	0.29	0.19	0.05	0.22
Recycling	Substitution ratio paper	0.49	0.88	0.81	0.74	0.51	0.17	0.52	0.58	0.50	0.84	0.59
	Substitution ratio cardboard	0.21	0.23	0.56	0.35	0.15	0.09	0.20	0.72	0.21	0.31	1.00
	Substitution ratio PET	0.04	0.03	0.05	0.05	0.03	0.02	0.01	0.04	0.05	0.10	0.03
	Substitution ratio HDPE	0.02	0.00	0.03	0.03	0.01	0.01	0.00	0.01	0.02	0.08	0.00
	Substitution ratio soft plastic	0.00	0.01	0.01	0.01	0.00	0.00	0.00	0.03	0.04	0.00	0.00
	Substitution ratio glass	0.10	0.05	0.33	0.33	0.22	0.07	0.06	0.17	0.44	0.13	0.12
	Substitution ratio aluminium	0.66	0.01	1.00	1.00	1.00	0.01	0.14	0.07	1.00	0.55	0.02
	Substitution ratio steel	0.21	0.86	0.31	0.33	0.16	1.00	0.14	1.00	0.48	0.18	0.54
	Emissions paper	0.15	0.00	0.16	0.17	0.07	0.00	0.00	0.00	0.02	0.00	0.00
	Emissions glass	0.11	0.00	0.28	0.28	0.17	0.00	0.00	0.00	0.16	0.00	0.00
	Emissions aluminium	0.00	0.00	0.02	0.02	0.02	0.00	0.00	0.00	0.01	0.00	0.00
	Emissions steel	0.00	0.00	0.02	0.02	0.00	0.04	1.00	0.23	0.02	0.00	0.00
	Electricity consumption paper	0.07	0.11	0.07	0.07	0.05	0.02	0.02	0.03	0.04	0.13	0.05
	Electricity consumption PET	0.00	0.00	0.00	0.00	0.00	0.00	0.00	0.00	0.00	0.00	0.00
	Electricity consumption HDPE	0.00	0.00	0.00	0.00	0.00	0.00	0.00	0.00	0.00	0.01	0.00
	Electricity consumption soft plastic	0.01	0.01	0.01	0.01	0.01	0.00	0.00	0.00	0.01	0.02	0.01
	Electricity consumption glass	0.00	0.00	0.00	0.00	0.00	0.00	0.00	0.00	0.00	0.00	0.00
	Electricity consumption aluminium	0.00	0.00	0.00	0.00	0.00	0.00	0.00	0.00	0.00	0.00	0.00
	Electricity consumption steel	0.02	0.04	0.02	0.02	0.02	0.01	0.01	0.01	0.02	0.04	0.02
	Heat consumption PET	0.00	0.00	0.00	0.00	0.00	0.00	0.00	0.00	0.00	0.00	0.00
	Heat consumption HDPE	0.00	0.00	0.00	0.00	0.00	0.00	0.00	0.00	0.00	0.00	0.00
	Heat consumption soft plastic	0.00	0.00	0.00	0.00	0.00	0.00	0.00	0.00	0.00	0.00	0.00
	Heat consumption glass	0.07	0.04	0.07	0.08	0.05	0.02	0.02	0.05	0.04	0.10	0.01
Heat consumption aluminium	0.02	0.01	0.02	0.02	0.01	0.00	0.01	0.01	0.01	0.03	0.00	
Ancillary material paper	0.05	0.00	0.06	0.05	0.03	0.00	0.00	0.01	0.02	0.08	0.00	
MBT	Transfer coefficient MBP_composting	0.00	0.00	0.00	0.01	0.00	0.00	0.00	0.01	0.00	0.01	0.00
	Transfer coefficient MBP_RDF	0.01	0.16	0.02	0.01	0.03	0.03	0.02	0.05	0.05	0.17	0.09
	Transfer coefficient MBP_AI	0.04	0.00	0.06	0.06	0.06	0.00	0.01	0.00	0.06	0.03	0.00
	Transfer coefficient MBP_steel	0.01	0.04	0.01	0.02	0.01	0.05	0.06	0.04	0.02	0.01	0.03
	Transfer coefficient MBS_RDF	0.00	0.08	0.00	0.01	0.02	0.02	0.01	0.03	0.03	0.08	0.04
	Transfer coefficient MBS_AI	0.01	0.00	0.02	0.02	0.02	0.00	0.00	0.00	0.02	0.01	0.00
	Transfer coefficient MBS_steel	0.00	0.02	0.01	0.01	0.00	0.02	0.04	0.01	0.01	0.00	0.01
WtE	Ancillary material	0.02	0.00	0.02	0.03	0.01	0.00	0.00	0.00	0.01	0.01	0.00
	Electricity recovery efficiency	0.49	1.00	0.33	0.30	0.13	0.08	0.09	0.14	0.11	1.00	0.63
	Heat recovery efficiency	0.42	0.36	0.35	0.35	0.19	0.10	0.10	0.30	0.20	0.71	0.16
	% Steel recovered	0.11	0.43	0.15	0.16	0.08	0.50	0.07	0.50	0.24	0.09	0.27
	% AI recovered	0.27	0.00	0.41	0.41	0.41	0.01	0.06	0.03	0.41	0.23	0.01
	Process specific emissions	0.00	0.00	0.89	0.90	0.16	0.00	0.00	0.00	0.02	0.00	0.00
	NOx in process specific emissions	0.00	0.00	0.89	0.90	0.16	0.00	0.00	0.00	0.02	0.00	0.00
	SO2 in process specific emissions	0.00	0.00	0.00	0.00	0.00	0.00	0.00	0.00	0.00	0.00	0.00
	Input specific emissions	1.00	0.00	0.00	0.00	0.00	0.01	0.06	0.05	0.00	0.00	0.00
	CO2 fossil in input specific emissions	1.00	0.00	0.00	0.00	0.00	0.00	0.00	0.00	0.00	0.00	0.00
	Hg in input specific emissions	0.00	0.00	0.00	0.00	0.00	0.01	0.06	0.00	0.00	0.00	0.00
	Cu in input specific emissions	0.00	0.00	0.00	0.00	0.00	0.00	0.00	0.04	0.00	0.00	0.00
Transport	0.04	0.00	0.08	0.08	0.02	0.00	0.03	0.05	0.01	0.62	0.00	

5.1.1.2 Denmark

	GW 100	FE	ME	TE	AC	HT-C	HT-NC	ET	PM	AD-F	AD-E
Household sorting	Sorting efficiency food	0.00	0.00	0.00	0.00	0.00	0.00	0.00	0.00	0.00	0.00
	Sorting efficiency paper	0.31	0.84	0.41	0.36	0.66	0.32	0.91	0.74	0.77	0.58
	Sorting efficiency cardboard	0.01	0.00	0.01	0.00	0.00	0.02	0.00	0.07	0.02	0.03
	Sorting efficiency plastic bottles	0.00	0.00	0.00	0.00	0.00	0.00	0.00	0.00	0.00	0.00
	Sorting efficiency hard plastic	0.01	0.00	0.00	0.00	0.01	0.00	0.00	0.00	0.01	0.01
	Sorting efficiency soft plastic	0.00	0.00	0.00	0.00	0.00	0.00	0.00	0.00	0.00	0.00
	Sorting efficiency glass	0.03	0.02	0.00	0.00	0.05	0.08	0.05	0.14	0.36	0.05
	Sorting efficiency aluminium	0.11	0.00	0.10	0.10	0.20	0.00	0.03	0.01	0.21	0.06
	Sorting efficiency steel	0.02	0.06	0.02	0.02	0.02	0.15	0.14	0.07	0.06	0.01
Recycling	Substitution ratio paper	0.81	1.00	0.77	0.71	1.00	0.42	1.00	0.87	1.00	1.00
	Substitution ratio cardboard	0.10	0.08	0.16	0.10	0.09	0.07	0.12	0.33	0.13	0.11
	Substitution ratio PET	0.00	0.00	0.00	0.00	0.00	0.00	0.00	0.00	0.01	0.01
	Substitution ratio HDPE	0.00	0.00	0.00	0.00	0.00	0.00	0.00	0.00	0.00	0.01
	Substitution ratio soft plastic	0.00	0.00	0.00	0.00	0.00	0.00	0.00	0.00	0.00	0.00
	Substitution ratio glass	0.11	0.04	0.21	0.22	0.29	0.11	0.07	0.18	0.61	0.11
	Substitution ratio aluminium	0.31	0.00	0.27	0.27	0.56	0.01	0.07	0.03	0.57	0.19
	Substitution ratio steel	0.14	0.40	0.12	0.13	0.13	1.00	0.11	0.62	0.40	0.09
	Emissions paper	0.25	0.00	0.16	0.16	0.13	0.00	0.00	0.00	0.05	0.00
	Emissions glass	0.12	0.00	0.18	0.18	0.22	0.00	0.01	0.00	0.22	0.00
	Emissions aluminium	0.00	0.00	0.01	0.01	0.01	0.00	0.00	0.00	0.00	0.00
	Emissions steel	0.00	0.00	0.00	0.00	0.00	0.02	0.36	0.07	0.01	0.00
	Electricity consumption paper	0.11	0.13	0.07	0.07	0.10	0.04	0.04	0.05	0.09	0.15
	Electricity consumption PET	0.00	0.00	0.00	0.00	0.00	0.00	0.00	0.00	0.00	0.00
	Electricity consumption HDPE	0.00	0.00	0.00	0.00	0.00	0.00	0.00	0.00	0.00	0.00
	Electricity consumption soft plastic	0.00	0.00	0.00	0.00	0.00	0.00	0.00	0.00	0.00	0.00
	Electricity consumption glass	0.00	0.00	0.00	0.00	0.00	0.00	0.00	0.00	0.00	0.00
	Electricity consumption aluminium	0.00	0.00	0.00	0.00	0.00	0.00	0.00	0.00	0.00	0.00
	Electricity consumption steel	0.02	0.02	0.01	0.01	0.01	0.01	0.00	0.01	0.01	0.02
	Heat consumption PET	0.00	0.00	0.00	0.00	0.00	0.00	0.00	0.00	0.00	0.00
	Heat consumption HDPE	0.00	0.00	0.00	0.00	0.00	0.00	0.00	0.00	0.00	0.00
	Heat consumption soft plastic	0.00	0.00	0.00	0.00	0.00	0.00	0.00	0.00	0.00	0.00
	Heat consumption glass	0.08	0.03	0.05	0.05	0.07	0.03	0.03	0.05	0.06	0.08
Heat consumption aluminium	0.01	0.00	0.00	0.00	0.01	0.00	0.00	0.00	0.00	0.01	
Ancillary material paper	0.09	0.00	0.06	0.05	0.05	0.01	0.01	0.01	0.04	0.09	
WtE	Ancillary material	0.05	0.00	0.02	0.03	0.03	0.00	0.00	0.00	0.01	0.02
	Electricity recovery efficiency	0.56	0.28	0.31	0.35	0.38	0.09	0.30	0.24	0.33	0.53
	Heat recovery efficiency	0.84	0.46	0.68	0.77	0.79	0.41	0.68	1.00	0.93	0.81
	% Steel recovered	0.12	0.34	0.10	0.11	0.11	0.84	0.09	0.52	0.34	0.07
	% Al recovered	0.19	0.00	0.17	0.17	0.35	0.01	0.05	0.02	0.36	0.12
	Process specific emissions	0.00	0.00	1.00	1.00	0.36	0.00	0.00	0.00	0.04	0.00
	NOx in process specific emissions	0.00	0.00	1.00	1.00	0.36	0.00	0.00	0.00	0.04	0.00
	SO2 in process specific emissions	0.00	0.00	0.00	0.00	0.00	0.00	0.00	0.00	0.00	0.00
	Input specific emissions	1.00	0.00	0.00	0.00	0.00	0.02	0.14	0.01	0.00	0.00
	CO2 fossil in input specific emissions	1.00	0.00	0.00	0.00	0.00	0.00	0.00	0.00	0.00	0.00
	Hg in input specific emissions	0.00	0.00	0.00	0.00	0.00	0.02	0.14	0.00	0.00	0.00
	Cu in input specific emissions	0.00	0.00	0.00	0.00	0.00	0.00	0.00	0.00	0.00	0.00
Transport	0.04	0.00	0.04	0.04	0.02	0.00	0.03	0.04	0.01	0.32	

5.1.1.3 France

		GW 100	FE	ME	TE	AC	HT-C	HT- NC	ET	PM	AD-F	AD-E	
Household sorting	Sorting efficiency food	0.01	0.09	0.11	0.03	0.02	0.01	0.29	0.18	0.01	0.02	0.00	
	Sorting efficiency paper	0.17	0.84	0.28	0.24	0.66	0.17	0.74	0.66	0.44	0.58	0.77	
	Sorting efficiency cardboard	0.01	0.00	0.02	0.00	0.00	0.02	0.00	0.11	0.02	0.06	0.39	
	Sorting efficiency plastic bottles	0.07	0.03	0.06	0.05	0.11	0.04	0.01	0.06	0.11	0.25	0.03	
	Sorting efficiency hard plastic	0.01	0.01	0.01	0.01	0.02	0.01	0.00	0.01	0.02	0.04	0.01	
	Sorting efficiency soft plastic	0.00	0.00	0.00	0.00	0.00	0.00	0.00	0.00	0.00	0.00	0.00	
	Sorting efficiency glass	0.04	0.05	0.00	0.00	0.13	0.13	0.12	0.36	0.58	0.13	0.17	
	Sorting efficiency aluminium	0.01	0.00	0.01	0.01	0.03	0.00	0.00	0.00	0.02	0.01	0.00	
	Sorting efficiency steel	0.04	0.21	0.03	0.04	0.06	0.27	0.39	0.20	0.11	0.03	0.19	
Recycling	Substitution ratio paper	0.44	1.00	0.53	0.48	1.00	0.23	0.81	0.77	0.58	1.00	1.00	
	Substitution ratio cardboard	0.10	0.13	0.19	0.12	0.16	0.07	0.17	0.51	0.13	0.19	0.88	
	Substitution ratio PET	0.07	0.06	0.06	0.06	0.11	0.05	0.03	0.09	0.12	0.22	0.10	
	Substitution ratio HDPE	0.02	0.01	0.02	0.02	0.03	0.01	0.00	0.01	0.03	0.11	0.00	
	Substitution ratio soft plastic	0.00	0.00	0.00	0.00	0.00	0.00	0.00	0.00	0.00	0.00	0.00	
	Substitution ratio glass	0.17	0.10	0.42	0.42	0.82	0.17	0.17	0.45	1.00	0.30	0.38	
	Substitution ratio aluminium	0.19	0.00	0.21	0.21	0.63	0.01	0.07	0.03	0.38	0.21	0.01	
	Substitution ratio steel	0.14	0.73	0.15	0.16	0.24	1.00	0.17	1.00	0.42	0.16	0.68	
	Emissions paper	0.14	0.00	0.11	0.11	0.13	0.00	0.00	0.00	0.03	0.00	0.00	
	Emissions glass	0.18	0.00	0.36	0.36	0.63	0.00	0.01	0.01	0.37	0.00	0.00	
	Emissions aluminium	0.00	0.00	0.00	0.00	0.00	0.00	0.00	0.00	0.00	0.00	0.00	
	Emissions steel	0.00	0.00	0.01	0.01	0.01	0.04	1.00	0.20	0.02	0.00	0.00	
	Electricity consumption paper	0.06	0.12	0.05	0.04	0.11	0.02	0.03	0.04	0.05	0.15	0.08	
	Electricity consumption PET	0.00	0.01	0.00	0.00	0.01	0.00	0.00	0.00	0.00	0.01	0.00	
	Electricity consumption HDPE	0.00	0.01	0.00	0.00	0.00	0.00	0.00	0.00	0.00	0.01	0.00	
	Electricity consumption soft plastic	0.00	0.00	0.00	0.00	0.00	0.00	0.00	0.00	0.00	0.00	0.00	
	Electricity consumption glass	0.00	0.01	0.00	0.00	0.00	0.00	0.00	0.00	0.00	0.01	0.00	
	Electricity consumption aluminium	0.00	0.00	0.00	0.00	0.00	0.00	0.00	0.00	0.00	0.00	0.00	
	Electricity consumption steel	0.02	0.03	0.01	0.01	0.03	0.01	0.00	0.01	0.01	0.04	0.02	
	Heat consumption PET	0.01	0.00	0.00	0.00	0.01	0.00	0.00	0.01	0.00	0.01	0.00	
	Heat consumption HDPE	0.00	0.00	0.00	0.00	0.00	0.00	0.00	0.00	0.00	0.00	0.00	
	Heat consumption soft plastic	0.00	0.00	0.00	0.00	0.00	0.00	0.00	0.00	0.00	0.00	0.00	
	Heat consumption glass	0.12	0.08	0.09	0.10	0.20	0.04	0.07	0.13	0.10	0.24	0.03	
	Heat consumption aluminium	0.00	0.00	0.00	0.00	0.01	0.00	0.00	0.00	0.00	0.01	0.00	
	Ancillary material paper	0.05	0.00	0.04	0.03	0.06	0.01	0.01	0.01	0.02	0.09	0.00	
	WtE	Ancillary material	0.04	0.00	0.03	0.03	0.04	0.00	0.00	0.00	0.01	0.03	0.00
		Electricity recovery efficiency	0.08	0.04	0.08	0.07	0.15	0.02	0.04	0.11	0.09	0.15	0.14
Heat recovery efficiency		0.27	0.11	0.25	0.27	0.38	0.06	0.21	0.40	0.24	0.53	0.08	
% Steel recovered		0.10	0.52	0.11	0.11	0.17	0.71	0.12	0.71	0.30	0.11	0.48	
% Al recovered		0.18	0.00	0.20	0.20	0.60	0.01	0.07	0.03	0.36	0.20	0.01	
Process specific emissions		0.00	0.00	1.00	1.00	0.52	0.00	0.00	0.00	0.04	0.00	0.00	
NOx in process specific emissions		0.00	0.00	1.00	1.00	0.52	0.00	0.00	0.00	0.03	0.00	0.00	
SO2 in process specific emissions		0.00	0.00	0.00	0.00	0.00	0.00	0.00	0.00	0.00	0.00	0.00	
Input specific emissions		1.00	0.00	0.00	0.00	0.00	0.00	0.04	0.01	0.00	0.00	0.00	
CO2 fossil in input specific emissions		1.00	0.00	0.00	0.00	0.00	0.00	0.00	0.00	0.00	0.00	0.00	
Hg in input specific emissions		0.00	0.00	0.00	0.00	0.00	0.00	0.04	0.00	0.00	0.00	0.00	
Cu in input specific emissions	0.00	0.00	0.00	0.00	0.00	0.00	0.00	0.01	0.00	0.00	0.00		
Landfill	Oxidation in top cover, daily	0.12	0.00	0.00	0.00	0.00	0.00	0.00	0.00	0.00	0.00	0.00	
	Oxidation in top cover, intermediate	0.10	0.00	0.00	0.00	0.00	0.00	0.00	0.00	0.00	0.00	0.00	
	Oxidation in top cover, final	0.18	0.00	0.00	0.00	0.00	0.00	0.00	0.00	0.00	0.00	0.00	
	Gas collected	0.73	0.01	0.15	0.15	0.06	0.01	0.01	0.03	0.01	0.04	0.02	
	Gas utilised	0.01	0.00	0.06	0.06	0.02	0.00	0.01	0.02	0.01	0.02	0.01	
	Net thermal efficiency, electricity	0.01	0.01	0.01	0.01	0.02	0.00	0.00	0.01	0.01	0.02	0.02	
	Net thermal efficiency, heat	0.01	0.00	0.01	0.01	0.02	0.00	0.01	0.02	0.01	0.02	0.00	
	Infiltration rate	0.00	0.01	0.26	0.00	0.02	0.00	0.03	0.51	0.01	0.00	0.00	
	C storage	0.47	0.00	0.00	0.00	0.00	0.00	0.00	0.00	0.00	0.00	0.00	
	Transport	0.04	0.00	0.07	0.07	0.04	0.00	0.05	0.07	0.01	0.70	0.00	

5.1.1.4 UK

		GW 100	FE	ME	TE	AC	HT-C	HT-NC	ET	PM	AD-F	AD-E
Household sorting	Sorting efficiency food	0.01	0.02	0.05	0.02	0.01	0.01	0.08	0.06	0.01	0.01	0.00
	Sorting efficiency paper	0.24	0.84	0.54	0.51	0.66	0.35	0.91	0.85	0.77	0.58	0.77
	Sorting efficiency cardboard	0.01	0.00	0.02	0.00	0.00	0.02	0.00	0.09	0.02	0.04	0.25
	Sorting efficiency plastic bottles	0.07	0.02	0.07	0.08	0.07	0.05	0.01	0.05	0.13	0.16	0.02
	Sorting efficiency hard plastic	0.03	0.01	0.03	0.03	0.03	0.02	0.01	0.03	0.05	0.06	0.01
	Sorting efficiency soft plastic	0.00	0.00	0.00	0.00	0.00	0.00	0.00	0.00	0.00	0.00	0.00
	Sorting efficiency glass	0.03	0.02	0.00	0.00	0.06	0.13	0.07	0.23	0.51	0.07	0.08
	Sorting efficiency aluminium	0.12	0.00	0.18	0.19	0.28	0.00	0.04	0.01	0.30	0.09	0.00
	Sorting efficiency steel	0.04	0.16	0.05	0.06	0.05	0.42	0.37	0.19	0.15	0.02	0.14
Recycling	Substitution ratio paper	0.62	1.00	1.00	1.00	1.00	0.47	1.00	1.00	1.00	1.00	1.00
	Substitution ratio cardboard	0.09	0.08	0.23	0.16	0.10	0.08	0.13	0.41	0.14	0.12	0.56
	Substitution ratio PET	0.08	0.05	0.09	0.10	0.09	0.08	0.03	0.10	0.17	0.18	0.08
	Substitution ratio HDPE	0.02	0.00	0.02	0.02	0.02	0.01	0.00	0.01	0.03	0.06	0.00
	Substitution ratio soft plastic	0.00	0.00	0.00	0.00	0.00	0.00	0.00	0.00	0.01	0.00	0.00
	Substitution ratio glass	0.14	0.06	0.41	0.46	0.43	0.18	0.11	0.30	0.88	0.17	0.19
	Substitution ratio aluminium	0.22	0.00	0.33	0.36	0.52	0.01	0.07	0.03	0.53	0.17	0.01
	Substitution ratio steel	0.10	0.36	0.14	0.16	0.12	1.00	0.10	0.64	0.36	0.08	0.34
	Emissions paper	0.19	0.00	0.21	0.22	0.13	0.00	0.00	0.00	0.05	0.00	0.00
	Emissions glass	0.15	0.00	0.36	0.39	0.33	0.00	0.01	0.01	0.33	0.02	0.00
	Emissions aluminium	0.00	0.00	0.01	0.01	0.01	0.00	0.00	0.00	0.00	0.00	0.00
	Emissions steel	0.00	0.00	0.01	0.01	0.00	0.04	0.63	0.13	0.01	0.00	0.00
	Electricity consumption paper	0.09	0.13	0.09	0.09	0.10	0.04	0.04	0.06	0.09	0.15	0.08
	Electricity consumption PET	0.01	0.01	0.01	0.01	0.01	0.00	0.00	0.00	0.01	0.01	0.00
	Electricity consumption HDPE	0.00	0.00	0.00	0.00	0.00	0.00	0.00	0.00	0.00	0.00	0.00
	Electricity consumption soft plastic	0.00	0.00	0.00	0.00	0.00	0.00	0.00	0.00	0.00	0.00	0.00
	Electricity consumption glass	0.02	0.01	0.01	0.02	0.01	0.00	0.00	0.01	0.01	0.02	0.00
	Electricity consumption aluminium	0.00	0.00	0.00	0.00	0.00	0.00	0.00	0.00	0.00	0.00	0.00
	Electricity consumption steel	0.01	0.02	0.01	0.01	0.01	0.01	0.01	0.01	0.01	0.02	0.01
	Heat consumption PET	0.01	0.00	0.01	0.01	0.01	0.00	0.00	0.01	0.01	0.01	0.00
	Heat consumption HDPE	0.00	0.00	0.00	0.00	0.00	0.00	0.00	0.00	0.00	0.00	0.00
	Heat consumption soft plastic	0.00	0.00	0.00	0.00	0.00	0.00	0.00	0.00	0.00	0.00	0.00
Heat consumption glass	0.10	0.04	0.10	0.11	0.11	0.04	0.04	0.09	0.09	0.14	0.02	
Heat consumption aluminium	0.01	0.00	0.01	0.01	0.01	0.00	0.00	0.01	0.01	0.01	0.00	
Ancillary material paper	0.07	0.00	0.08	0.07	0.06	0.01	0.01	0.01	0.04	0.09	0.01	
WtE	Ancillary material	0.02	0.00	0.02	0.02	0.01	0.00	0.00	0.00	0.01	0.01	0.00
	Electricity recovery eff	0.38	0.21	0.45	0.49	0.57	0.18	0.19	0.27	0.38	0.49	0.26
	Heat recovery eff	0.35	0.18	0.28	0.31	0.23	0.06	0.03	0.08	0.83	0.71	0.03
	% Steel recovered	0.05	0.20	0.08	0.09	0.06	0.56	0.06	0.35	0.20	0.04	0.19
	% Al recovered	0.09	0.00	0.14	0.15	0.22	0.00	0.03	0.01	0.23	0.08	0.00
	Process specific emissions	0.00	0.00	0.66	0.71	0.18	0.00	0.00	0.00	0.02	0.00	0.00
	NOx in process specific emissions	0.00	0.00	0.66	0.71	0.18	0.00	0.00	0.00	0.02	0.00	0.00
	SO2 in process specific emissions	0.00	0.00	0.00	0.00	0.00	0.00	0.00	0.00	0.00	0.00	0.00
	Input specific emissions	0.59	0.00	0.00	0.00	0.00	0.01	0.06	0.01	0.00	0.00	0.00
	CO2 fossil in input specific emissions	0.59	0.00	0.00	0.00	0.00	0.00	0.00	0.00	0.00	0.00	0.00
	Hg in input specific emissions	0.00	0.00	0.00	0.00	0.00	0.01	0.06	0.00	0.00	0.00	0.00
Cu in input specific emissions	0.00	0.00	0.00	0.00	0.00	0.00	0.00	0.01	0.00	0.00	0.00	
Landfill	Oxidation in top cover, daily	0.13	0.00	0.00	0.00	0.00	0.00	0.00	0.00	0.00	0.00	0.00
	Oxidation in top cover, intermediate	0.10	0.00	0.00	0.00	0.00	0.00	0.00	0.00	0.00	0.00	0.00
	Oxidation in top cover, final	0.16	0.00	0.00	0.00	0.00	0.00	0.00	0.00	0.00	0.00	0.00
	Gas collected	1.00	0.06	0.13	0.14	0.08	0.05	0.05	0.07	0.08	0.13	0.07
	Gas utilised	0.04	0.02	0.04	0.04	0.04	0.02	0.02	0.03	0.04	0.06	0.03
	Net thermal efficiency, electricity	0.10	0.06	0.12	0.13	0.15	0.05	0.05	0.07	0.10	0.13	0.07
	Net thermal efficiency, heat	0.00	0.00	0.00	0.00	0.00	0.00	0.00	0.00	0.00	0.00	0.00
	Infiltration rate	0.01	0.00	0.38	0.01	0.01	0.00	0.03	0.51	0.00	0.01	0.01
	C storage	0.48	0.00	0.00	0.00	0.00	0.00	0.00	0.00	0.00	0.00	0.00
Transport	0.04	0.00	0.07	0.08	0.03	0.00	0.04	0.06	0.01	0.41	0.00	

5.1.1.5 Italy

		GW1 OO	FE	ME	TE	AC	HT-C	HT- NC	ET	PM	AD-F	AD-E
Household sorting	Sorting efficiency food	0.04	0.21	0.44	0.16	0.04	0.03	0.77	0.50	0.03	0.05	0.01
	Sorting efficiency paper	0.32	0.84	0.54	0.51	0.48	0.25	0.91	0.85	0.54	0.58	0.77
	Sorting efficiency cardboard	0.01	0.00	0.03	0.00	0.00	0.03	0.00	0.16	0.03	0.06	0.43
	Sorting efficiency plastic bottles	0.13	0.03	0.10	0.11	0.08	0.06	0.02	0.08	0.13	0.24	0.03
	Sorting efficiency hard plastic	0.02	0.00	0.01	0.01	0.01	0.01	0.00	0.01	0.01	0.04	0.00
	Sorting efficiency soft plastic	0.01	0.01	0.01	0.01	0.00	0.00	0.00	0.02	0.03	0.02	0.01
	Sorting efficiency glass	0.05	0.03	0.00	0.00	0.07	0.12	0.10	0.31	0.48	0.09	0.12
	Sorting efficiency aluminium	0.23	0.00	0.24	0.26	0.28	0.00	0.05	0.02	0.29	0.13	0.01
	Sorting efficiency steel	0.05	0.12	0.04	0.05	0.03	0.23	0.28	0.15	0.08	0.02	0.11
Recycling	Substitution ratio paper	0.83	1.00	1.00	1.00	0.73	0.33	1.00	1.00	0.70	1.00	1.00
	Substitution ratio cardboard	0.20	0.15	0.39	0.27	0.12	0.10	0.22	0.71	0.17	0.21	0.96
	Substitution ratio PET	0.11	0.05	0.10	0.11	0.07	0.06	0.03	0.10	0.12	0.19	0.08
	Substitution ratio HDPE	0.05	0.01	0.04	0.04	0.02	0.02	0.00	0.02	0.04	0.11	0.00
	Substitution ratio soft plastic	0.00	0.00	0.01	0.01	0.00	0.00	0.00	0.03	0.03	0.00	0.00
	Substitution ratio glass	0.22	0.07	0.54	0.60	0.41	0.17	0.14	0.40	0.83	0.20	0.26
	Substitution ratio aluminium	0.78	0.01	0.88	0.95	1.00	0.02	0.18	0.08	1.00	0.46	0.03
	Substitution ratio steel	0.19	0.51	0.20	0.23	0.12	1.00	0.14	0.90	0.35	0.11	0.48
	Emissions paper	0.26	0.00	0.20	0.22	0.09	0.00	0.00	0.00	0.03	0.00	0.00
	Emissions glass	0.24	0.00	0.47	0.51	0.31	0.00	0.01	0.01	0.31	0.00	0.00
	Emissions aluminium	0.00	0.00	0.02	0.02	0.02	0.00	0.00	0.00	0.01	0.00	0.00
	Emissions steel	0.00	0.00	0.01	0.01	0.00	0.04	0.93	0.20	0.01	0.00	0.00
	Electricity consumption paper	0.12	0.13	0.09	0.09	0.08	0.03	0.04	0.06	0.06	0.15	0.08
	Electricity consumption PET	0.01	0.01	0.00	0.01	0.00	0.00	0.00	0.00	0.00	0.01	0.00
	Electricity consumption HDPE	0.01	0.01	0.00	0.00	0.00	0.00	0.00	0.00	0.00	0.01	0.00
	Electricity consumption soft plastic	0.01	0.01	0.01	0.01	0.01	0.00	0.00	0.00	0.00	0.01	0.01
	Electricity consumption glass	0.00	0.00	0.00	0.00	0.00	0.00	0.00	0.00	0.00	0.01	0.00
	Electricity consumption aluminium	0.00	0.00	0.00	0.00	0.00	0.00	0.00	0.00	0.00	0.00	0.00
	Electricity consumption steel	0.02	0.02	0.01	0.02	0.01	0.00	0.01	0.01	0.01	0.03	0.01
	Heat consumption PET	0.01	0.00	0.01	0.01	0.01	0.00	0.00	0.01	0.00	0.01	0.00
	Heat consumption HDPE	0.00	0.00	0.00	0.00	0.00	0.00	0.00	0.00	0.00	0.00	0.00
	Heat consumption soft plastic	0.00	0.00	0.00	0.00	0.00	0.00	0.00	0.00	0.00	0.00	0.00
Heat consumption glass	0.15	0.06	0.12	0.14	0.10	0.04	0.06	0.11	0.08	0.16	0.02	
Heat consumption aluminium	0.02	0.01	0.02	0.02	0.01	0.00	0.01	0.01	0.01	0.02	0.00	
Ancillary material paper	0.09	0.00	0.08	0.07	0.04	0.01	0.01	0.01	0.03	0.09	0.00	
MBT	Transfer coefficient MBP_composting	0.00	0.00	0.01	0.00	0.00	0.00	0.01	0.05	0.00	0.02	0.01
	Transfer coefficient MBP_RDF	0.03	0.09	0.14	0.14	0.26	0.09	0.07	0.39	0.28	0.35	0.30
	Transfer coefficient MBP_AI	0.20	0.00	0.22	0.24	0.25	0.01	0.05	0.02	0.26	0.12	0.01
	Transfer coefficient MBP_steel	0.04	0.11	0.04	0.05	0.02	0.21	0.26	0.14	0.07	0.02	0.10
WtE	Ancillary material	0.03	0.00	0.02	0.03	0.01	0.00	0.00	0.00	0.01	0.01	0.00
	Electricity recovery eff	0.62	0.16	0.52	0.54	0.41	0.06	0.10	0.33	0.35	0.60	0.56
	Heat recovery eff	0.31	0.04	0.34	0.36	0.28	0.04	0.09	0.43	0.25	0.31	0.23
	% Steel recovered	0.10	0.27	0.11	0.12	0.06	0.54	0.08	0.49	0.19	0.06	0.26
	% AI recovered	0.35	0.00	0.39	0.43	0.45	0.01	0.08	0.04	0.45	0.21	0.01
	Process specific emissions	0.00	0.00	0.83	0.90	0.17	0.00	0.00	0.00	0.02	0.00	0.00
	NOx in process specific	0.00	0.00	0.83	0.90	0.16	0.00	0.00	0.00	0.02	0.00	0.00
	SO2 in process specific	0.00	0.00	0.00	0.00	0.00	0.00	0.00	0.00	0.00	0.00	0.00
	Input specific emissions	0.95	0.00	0.00	0.00	0.00	0.00	0.04	0.01	0.00	0.00	0.00
	CO2 fossil in input specific emiss.	0.95	0.00	0.00	0.00	0.00	0.00	0.00	0.00	0.00	0.00	0.00
	Hg in input specific emissions	0.00	0.00	0.00	0.00	0.00	0.00	0.00	0.04	0.00	0.00	0.00
Cu in input specific emissions	0.00	0.00	0.00	0.00	0.00	0.00	0.00	0.01	0.00	0.00	0.00	
Landfill	Oxidation in top cover, daily	0.28	0.00	0.00	0.00	0.00	0.00	0.00	0.00	0.00	0.00	0.00
	Oxidation in top cover, intermediate	0.25	0.00	0.00	0.00	0.00	0.00	0.00	0.00	0.00	0.00	0.00
	Oxidation in top cover, final	0.44	0.00	0.00	0.00	0.00	0.00	0.00	0.00	0.00	0.00	0.00
	Gas collected	0.81	0.02	0.11	0.13	0.02	0.01	0.01	0.05	0.04	0.08	0.07
	Gas utilised	0.08	0.02	0.08	0.09	0.03	0.01	0.01	0.05	0.04	0.08	0.07
	Net thermal efficiency, electricity	0.08	0.02	0.06	0.07	0.05	0.01	0.01	0.04	0.04	0.07	0.07
	Net thermal efficiency, heat	0.01	0.00	0.01	0.01	0.01	0.00	0.00	0.01	0.01	0.01	0.00
	Infiltration rate	0.01	0.00	0.43	0.01	0.01	0.01	0.04	0.58	0.00	0.01	0.01
	C storage	1.00	0.00	0.00	0.00	0.00	0.00	0.00	0.00	0.00	0.00	0.00
Transport	0.08	0.00	0.11	0.12	0.03	0.00	0.06	0.09	0.01	0.62	0.00	

5.1.1.6 Poland

		GW 100	FE	ME	TE	AC	HT-C	HT- NC	ET	PM	AD-F	AD-E	
Household sorting	Sorting efficiency food	0.01	0.07	0.10	0.08	0.05	0.03	0.67	0.09	0.02	0.04	0.01	
	Sorting efficiency paper	0.03	0.32	0.08	0.21	0.28	0.18	0.50	0.09	0.16	0.18	0.70	
	Sorting efficiency cardboard	0.00	0.00	0.01	0.00	0.00	0.02	0.00	0.02	0.01	0.02	0.45	
	Sorting efficiency plastic bottles	0.04	0.03	0.04	0.13	0.13	0.12	0.02	0.02	0.11	0.21	0.07	
	Sorting efficiency hard plastic	0.01	0.01	0.01	0.03	0.03	0.03	0.00	0.00	0.02	0.07	0.03	
	Sorting efficiency soft plastic	0.01	0.02	0.01	0.03	0.02	0.02	0.00	0.01	0.05	0.05	0.06	
	Sorting efficiency glass	0.02	0.04	0.00	0.00	0.15	0.36	0.21	0.14	0.58	0.11	0.42	
	Sorting efficiency aluminium	0.02	0.00	0.03	0.09	0.14	0.00	0.02	0.00	0.07	0.03	0.00	
	Sorting efficiency steel	0.01	0.10	0.01	0.04	0.03	0.35	0.34	0.03	0.05	0.01	0.22	
Recycling	Substitution ratio paper	0.08	0.38	0.15	0.41	0.43	0.24	0.55	0.11	0.21	0.32	0.91	
	Substitution ratio cardboard	0.02	0.06	0.07	0.13	0.09	0.09	0.14	0.09	0.06	0.08	1.00	
	Substitution ratio PET	0.03	0.05	0.04	0.12	0.11	0.11	0.04	0.03	0.09	0.16	0.20	
	Substitution ratio HDPE	0.02	0.01	0.03	0.08	0.07	0.06	0.00	0.01	0.05	0.16	0.02	
	Substitution ratio soft plastic	0.00	0.01	0.01	0.02	0.00	0.01	0.01	0.02	0.06	0.00	0.01	
	Substitution ratio glass	0.09	0.11	0.32	1.00	1.00	0.49	0.33	0.18	1.00	0.26	0.97	
	Substitution ratio aluminium	0.05	0.00	0.08	0.24	0.37	0.01	0.06	0.01	0.18	0.09	0.02	
	Substitution ratio steel	0.03	0.27	0.04	0.13	0.10	1.00	0.11	0.13	0.14	0.05	0.60	
	Emissions paper	0.03	0.00	0.03	0.09	0.06	0.00	0.00	0.00	0.01	0.00	0.00	
	Emissions glass	0.10	0.00	0.28	0.85	0.77	0.00	0.02	0.00	0.37	0.00	0.00	
	Emissions aluminium	0.00	0.00	0.00	0.01	0.01	0.00	0.00	0.00	0.00	0.00	0.00	
	Emissions steel	0.00	0.00	0.00	0.01	0.00	0.06	1.00	0.04	0.01	0.00	0.00	
	Electricity consumption paper	0.01	0.05	0.01	0.04	0.05	0.02	0.02	0.01	0.02	0.05	0.07	
	Electricity consumption PET	0.00	0.01	0.00	0.01	0.01	0.00	0.00	0.00	0.00	0.01	0.01	
	Electricity consumption HDPE	0.00	0.01	0.00	0.01	0.01	0.01	0.00	0.00	0.00	0.01	0.02	
	Electricity consumption soft plastic	0.01	0.02	0.01	0.02	0.02	0.01	0.01	0.00	0.01	0.02	0.03	
	Electricity consumption glass	0.00	0.01	0.00	0.01	0.01	0.00	0.00	0.00	0.00	0.01	0.01	
	Electricity consumption aluminium	0.00	0.00	0.00	0.00	0.00	0.00	0.00	0.00	0.00	0.00	0.00	
	Electricity consumption steel	0.00	0.01	0.00	0.01	0.01	0.00	0.01	0.00	0.00	0.01	0.02	
	Heat consumption PET	0.00	0.00	0.00	0.01	0.01	0.00	0.00	0.00	0.00	0.01	0.00	
	Heat consumption HDPE	0.00	0.00	0.00	0.00	0.00	0.00	0.00	0.00	0.00	0.00	0.00	
	Heat consumption soft plastic	0.00	0.00	0.00	0.00	0.01	0.00	0.00	0.00	0.00	0.00	0.00	
	Heat consumption glass	0.06	0.09	0.07	0.23	0.25	0.12	0.13	0.05	0.10	0.21	0.08	
	Heat consumption aluminium	0.00	0.00	0.00	0.00	0.01	0.00	0.00	0.00	0.00	0.00	0.00	
	Ancillary material paper	0.01	0.00	0.01	0.03	0.02	0.01	0.01	0.00	0.01	0.03	0.01	
	MBT	Transfer coefficient MBP_composting	0.00	0.00	0.00	0.04	0.01	0.00	0.00	0.01	0.01	0.03	0.00
		Transfer coefficient MBP_RDF	0.00	0.00	0.00	0.00	0.00	0.00	0.00	0.00	0.00	0.00	0.00
		Transfer coefficient MBP_AI	0.03	0.00	0.05	0.14	0.22	0.01	0.04	0.00	0.11	0.05	0.01
Transfer coefficient MBP_steel		0.02	0.17	0.02	0.08	0.06	0.59	0.56	0.06	0.09	0.03	0.37	
Landfill	Oxidation in top cover, daily	0.44	0.00	0.00	0.00	0.00	0.00	0.00	0.00	0.00	0.00	0.00	
	Oxidation in top cover, intermediate	0.39	0.00	0.00	0.00	0.00	0.00	0.00	0.00	0.00	0.00	0.00	
	Oxidation in top cover, final	0.59	0.00	0.00	0.00	0.00	0.00	0.00	0.00	0.00	0.00	0.00	
	Gas collected	0.83	0.44	0.10	0.25	0.35	0.25	0.28	0.03	0.15	0.44	0.07	
	Gas utilised	0.23	1.00	0.05	0.15	0.98	0.58	0.66	0.12	0.39	1.00	0.16	
	Net thermal efficiency, electricity	0.09	0.43	0.10	0.32	0.49	0.23	0.27	0.05	0.16	0.40	0.07	
	Net thermal efficiency, heat	0.02	0.03	0.01	0.04	0.08	0.04	0.04	0.01	0.03	0.06	0.01	
	Infiltration rate	0.04	0.11	1.00	0.09	0.02	0.01	0.24	1.00	0.02	0.15	0.03	
	C storage	1.00	0.00	0.00	0.00	0.00	0.00	0.00	0.00	0.00	0.00	0.00	
Transport	0.04	0.00	0.08	0.23	0.08	0.00	0.15	0.04	0.01	0.87	0.00		

5.1.1.7 Greece

		GW 100	FE	ME	TE	AC	HT-C	HT- NC	ET	PM	AD-F	AD-E
Household Sorting	Sorting efficiency food	0.00	0.00	0.00	0.00	0.00	0.00	0.00	0.00	0.00	0.00	0.00
	Sorting efficiency paper	0.04	0.21	0.12	0.51	0.49	0.14	0.40	0.15	0.50	0.18	0.77
	Sorting efficiency cardboard	0.00	0.00	0.00	0.00	0.00	0.01	0.00	0.01	0.01	0.01	0.19
	Sorting efficiency plastic bottles	0.00	0.00	0.00	0.00	0.00	0.00	0.00	0.00	0.00	0.00	0.00
	Sorting efficiency hard plastic	0.02	0.01	0.03	0.15	0.10	0.04	0.01	0.02	0.16	0.10	0.04
	Sorting efficiency soft plastic	0.00	0.01	0.01	0.03	0.01	0.01	0.00	0.01	0.06	0.02	0.03
	Sorting efficiency glass	0.00	0.00	0.00	0.00	0.04	0.05	0.03	0.04	0.30	0.02	0.07
	Sorting efficiency aluminium	0.10	0.00	0.19	0.89	0.97	0.01	0.08	0.01	0.90	0.14	0.02
	Sorting efficiency steel	0.04	0.22	0.07	0.34	0.19	0.93	0.90	0.18	0.53	0.04	0.79
Recycling	Substitution ratio paper	0.11	0.26	0.23	1.00	0.74	0.19	0.44	0.17	0.66	0.32	1.00
	Substitution ratio cardboard	0.01	0.02	0.04	0.12	0.06	0.03	0.04	0.06	0.07	0.03	0.43
	Substitution ratio PET	0.02	0.02	0.03	0.15	0.10	0.05	0.02	0.02	0.16	0.08	0.11
	Substitution ratio HDPE	0.00	0.00	0.01	0.03	0.02	0.01	0.00	0.00	0.02	0.02	0.00
	Substitution ratio soft plastic	0.00	0.00	0.00	0.02	0.00	0.00	0.00	0.01	0.07	0.00	0.01
	Substitution ratio glass	0.02	0.01	0.08	0.39	0.27	0.06	0.04	0.04	0.51	0.04	0.17
	Substitution ratio aluminium	0.10	0.00	0.20	0.93	1.00	0.01	0.08	0.01	0.92	0.15	0.03
	Substitution ratio steel	0.04	0.23	0.08	0.40	0.21	1.00	0.11	0.27	0.58	0.06	0.82
	Emissions paper	0.03	0.00	0.05	0.22	0.10	0.00	0.00	0.00	0.03	0.00	0.00
	Emissions glass	0.02	0.00	0.07	0.33	0.21	0.00	0.00	0.00	0.19	0.00	0.00
	Emissions aluminium	0.00	0.00	0.01	0.03	0.02	0.00	0.00	0.00	0.01	0.00	0.00
	Emissions steel	0.00	0.00	0.00	0.03	0.01	0.06	1.00	0.08	0.03	0.00	0.00
	Electricity consumption paper	0.01	0.03	0.02	0.09	0.08	0.02	0.02	0.01	0.06	0.05	0.08
	Electricity consumption PET	0.00	0.00	0.00	0.01	0.01	0.00	0.00	0.00	0.00	0.00	0.01
	Electricity consumption HDPE	0.00	0.00	0.00	0.00	0.00	0.00	0.00	0.00	0.00	0.00	0.00
	Electricity consumption soft plastic	0.00	0.01	0.00	0.02	0.01	0.00	0.00	0.00	0.01	0.01	0.01
	Electricity consumption glass	0.00	0.00	0.00	0.00	0.00	0.00	0.00	0.00	0.00	0.00	0.00
	Electricity consumption aluminium	0.00	0.00	0.00	0.00	0.00	0.00	0.00	0.00	0.00	0.00	0.00
	Electricity consumption steel	0.00	0.01	0.01	0.03	0.02	0.00	0.00	0.00	0.02	0.01	0.02
	Heat consumption PET	0.00	0.00	0.00	0.01	0.01	0.00	0.00	0.00	0.01	0.00	0.00
	Heat consumption HDPE	0.00	0.00	0.00	0.00	0.00	0.00	0.00	0.00	0.00	0.00	0.00
	Heat consumption soft plastic	0.00	0.00	0.00	0.00	0.00	0.00	0.00	0.00	0.00	0.00	0.00
Heat consumption glass	0.01	0.01	0.02	0.09	0.07	0.01	0.02	0.01	0.05	0.03	0.01	
Heat consumption aluminium	0.00	0.00	0.00	0.02	0.01	0.00	0.00	0.00	0.01	0.01	0.00	
Ancillary material paper	0.01	0.00	0.02	0.07	0.04	0.01	0.00	0.00	0.02	0.03	0.01	
Landfill	Oxidation in top cover, daily	0.78	0.00	0.00	0.00	0.00	0.00	0.00	0.00	0.00	0.00	0.00
	Oxidation in top cover, intermediate	0.68	0.00	0.00	0.00	0.00	0.00	0.00	0.00	0.00	0.00	0.00
	Oxidation in top cover, final	0.86	0.00	0.00	0.00	0.00	0.00	0.00	0.00	0.00	0.00	0.00
	Gas collected	0.64	0.43	0.10	0.48	0.34	0.26	0.07	0.08	0.40	0.43	0.05
	Gas utilised	0.17	1.00	0.11	0.56	0.95	0.62	0.16	0.19	1.00	1.00	0.11
	Net thermal efficiency, electricity	0.06	0.34	0.06	0.28	0.43	0.21	0.05	0.08	0.37	0.35	0.05
	Net thermal efficiency, heat	0.01	0.09	0.01	0.06	0.09	0.05	0.01	0.01	0.07	0.08	0.00
	Infiltration rate	0.02	0.11	1.00	0.11	0.00	0.04	0.15	1.00	0.06	0.13	0.02
	C storage	1.00	0.00	0.00	0.00	0.00	0.00	0.00	0.00	0.00	0.00	0.00
	Transport	0.02	0.00	0.05	0.24	0.06	0.00	0.05	0.03	0.02	0.40	0.00

5.1.2 Scenario analysis

The scenario analysis was conducted in order to complete the obtained additional information at the side of the perturbation analysis. The most uncertain processes were modified and substituted with data found in literature or in the ecoinvent/EASETECH database to test the importance that the modelling of these processes have on the overall scenario.

The changes of the overall results were quantified calculating the Relative % that is described by the following formula:

$$\text{Relative \%} = \frac{|Results_{scenario}| - |Result_{baseline}|}{|Results_{baseline}|}$$

Following this paragraph are listed the relative % in each country. To simplify the interpretation of the scenario analysis, colours were chosen in order to define when the parameters showed a low, medium or high relative % (Table 98).

Table 98: Scale of colour to interpret the relative % in the following paragraphs

Negligible	Relative % < 0.1
Low	0.1 < Relative % < 0.5
Medium	0.5 < Relative % < 0.8
High	0.8 < Relative % < 1
0-00	By increasing/decreasing the parameter, no change was observed in the results. It includes the parameters that are not present in one specific country.

Results show that the scenarios the affect the most the results concern the substituted material from paper recycling and the energy modelling. Energy modelling is particularly important in Denmark.

The following additional considerations can be made on these results:

- In Germany, Denmark and Italy, relative percentage higher of 20% are seen only when recycled paper is substituted and when "clean" and "dirty" energies are modelled. Generally, capital goods modelling in general are much less important also seen the dimension of the system. Changing the capital goods of WtE plants in France and of trucks in Greece affects HT-NC and TE, respectively. Due to the great contribution of capital good in the resources depletion in Poland, changing the capital goods in the system showed low relative percentage in these two impact categories.
- The scenario that shows the greatest general environmental dramatic worsening is obtained when recycled paper substituted recycled paper instead that virgin paper. These results highlight the importance to know the substituted materials in the market because different assumptions could change the overall conclusions.
- Modelling of the energy (both electricity and heat) is essential in particular in the countries that present energy recovery. A smaller but not negligible relative percentage is also in countries where there is no incineration of waste as Poland and Greece due to the gas reutilization in the landfills. Out of all the countries, Denmark illustrates the greatest variation in the overall results by energy modelling because of the important that these processes have in the results. The more one country invested in clean energy, the more the environmental performance of energy recovery worsened as in France.

A particular attention is put on the scenarios that switch the sign of the overall scenario, from negative to positive (from saving to load) or vice versa (from load to saving). These cases are presented in Table 99. Furthermore, Table 100 shows the cases causing a high change relative percentage, as it can been seen TE, HT-NC and *Eco-toxicity, total* are the impact categories most affected by the scenario analysis.

Table 99: cases for which the sign of the overall results switches from negative to positive or vice-versa. *Even if the result of the scenario changes the sign of the results, the relative % has a low value. For Germany and Denmark there is no scenario in which the sign is reversed.

Country	Impact category	Scenarios
Germany	-	-
Denmark	-	-
France	GW (from load to saving)	Dirty heat
	TE (from load to saving)	Dirty heat
	HT-NC (from load to saving)	Dirty heat
UK	ME (from saving to load)	Substituting recycled paper Clean electricity
	NT-NC (from saving to load)	Recycled paper
Italy	GW (from saving to load)	
Greece	GW (from load to saving)	
	TE (from saving to load)	Substituting recycled paper Clean electricity *
	ME (from saving to load)	Substituting recycled paper Clean electricity
Poland	GW	
	AD-F (from saving to load)	Substituting recycled paper* Clean electricity *

Table 100: Scenario that cause a high relative percentage

Country	Impact category	Scenarios
Germany	HT-NC	Substituting recycled paper
	ET	Dirty heat
Denmark	ME	Dirty heat
	TE	Dirty electricity Clean heat Clean electricity
	HT-C	Dirty heat
	HT-NC	Dirty electricity
	ET	Dirty heat
France	GW	Substituting recycled paper Dirty heat
	TE	Dirty heat
	HT-NC	Substituting recycled paper CG WtE plant Clean heat Dirty heat
	ET	Dirty heat
UK	ME	Dirty electricity Dirty heat
	TE	Dirty heat
	PM	Dirty heat
Italy	ME	Dirty electricity Dirty heat
	TE	Dirty electricity
	HT-NC	Substituting recycled paper
	ET	Dirty electricity
Poland	GW	
	AD-F	CG landfill Dirty electricity
Greece	GW	
	TE	Substituting recycled paper Dirty electricity

5.1.2.1 Germany

	GW	FE	ME	TE	AC	HT-C	HT-NC	ET	PM	AD-F	AD-E
Recycled paper	-0.31	-0.24	-0.46	-0.40	-0.21	-0.10	0.87	0.02	0.03	-0.22	-0.14
CG WtE plant	0.00	0.00	0.00	0.00	0.00	-0.06	0.06	-0.04	0.00	0.00	0.00
CG landfill	-0.01	0.00	-0.03	-0.02	0.00	-0.03	0.01	-0.10	0.00	-0.02	0.00
CG composting plant	0.00	0.00	0.00	0.00	0.00	0.00	0.00	0.00	0.00	0.00	-0.03
CG AD plant	0.00	0.00	0.00	0.00	0.00	0.00	0.00	0.00	0.00	0.00	0.00
CG truck	-0.03	0.00	-0.05	-0.04	-0.02	-0.01	0.00	-0.09	-0.01	-0.03	0.02
Soil composting	0.00	0.00	-0.01	0.00	0.00	0.00	0.00	0.00	0.00	0.00	0.00
Clean electricity	-0.50	-0.29	-0.26	-0.22	-0.07	-0.05	0.16	-0.06	-0.04	-0.33	-0.41
Dirty electricity	0.48	0.76	0.10	0.12	0.03	0.10	0.03	-0.02	0.00	0.49	-0.45
Clean heat	-0.22	-0.11	-0.22	-0.20	-0.08	-0.07	0.21	-0.16	-0.06	-0.12	-0.11
Dirty heat	0.06	0.01	0.71	0.59	0.31	0.32	-0.38	0.80	0.30	-0.02	0.35

5.1.2.2 Denmark

	GW	FE	ME	TE	AC	HT-C	HT-NC	ET	PM	AD-F	AD-E
Recycled paper	0.42	0.42	0.65	0.56	0.31	0.11	0.49	-0.12	-0.05	0.31	0.19
CG WtE plant	0.01	0.00	0.00	0.00	0.00	0.11	0.04	0.04	-0.01	0.00	0.00
CG landfill	0.00	0.00	0.00	0.00	0.00	0.00	0.00	0.00	0.00	0.00	0.00
CG truck	0.01	0.00	0.01	0.01	0.01	-0.01	0.00	-0.01	0.00	0.00	-0.01
Clean electricity	0.52	0.12	0.44	0.46	0.17	-0.02	0.17	0.06	0.09	0.25	0.19
Dirty electricity	0.47	-0.10	-0.74	-1.19	-0.07	0.00	-1.13	-0.31	-0.19	0.23	0.19
Clean heat	0.32	0.22	0.78	0.82	0.34	0.21	0.41	0.36	0.27	0.07	0.18
Dirty heat	-0.33	-0.12	-1.39	-1.01	-0.59	-0.82	-0.09	-1.03	-0.58	-0.19	-0.77

5.1.2.3 France

	GW	FE	ME	TE	AC	HT-C	HT-NC	ET	PM	AD-F	AD-E
Recycled paper	-1.67	0.44	-0.45	-0.78	0.43	0.09	-13.54	-0.16	-0.04	0.38	0.22
CG WtE plant	-0.04	0.00	0.00	0.00	0.00	0.12	-1.52	0.08	-0.01	0.01	0.00
CG landfill	-0.01	0.00	-0.01	-0.02	0.00	0.01	-0.09	0.01	0.00	0.00	0.02
CG composting plant	0.00	0.00	0.00	0.00	0.00	0.00	-0.03	0.00	0.00	0.00	0.02
CG trucks	-0.10	0.00	-0.02	-0.03	0.03	-0.02	0.16	-0.01	0.01	0.01	-0.03
Soil composting	0.00	0.00	0.00	0.00	0.00	0.00	0.00	0.00	0.00	0.00	0.00
Clean electricity	-0.59	0.02	-0.13	-0.22	0.10	0.01	-0.74	0.06	0.04	0.10	0.10
Dirty electricity	-0.06	0.00	-0.01	-0.02	0.01	0.00	-0.07	0.00	0.00	0.01	0.01
Clean heat	-0.06	0.04	-0.23	-0.47	0.15	0.03	-4.18	0.19	0.08	-0.01	0.04
Dirty heat	0.91	-0.19	0.72	0.85	-0.64	-0.48	-2.90	-1.05	-0.39	-0.15	-0.68

5.1.2.4 UK

	GW	FE	ME	TE	AC	HT-C	HT-NC	ET	PM	AD-F	AD-E
Recycled paper	-0.38	-0.49	-0.63	-0.70	-0.32	-0.13	-0.74	0.23	0.04	-0.29	-0.38
CG WtE plant	0.00	0.00	0.00	0.00	0.00	-0.07	-0.05	-0.04	0.00	0.00	0.00
CG landfills	0.00	0.00	0.00	0.00	0.00	0.00	0.00	0.00	0.00	0.00	0.00
CG compost plant	0.00	0.00	0.00	0.00	0.00	0.00	0.00	0.00	0.00	0.00	-0.01
CG trucks	-0.01	0.00	-0.03	-0.01	-0.01	0.02	0.01	0.01	0.00	0.00	0.02
Soil composting	0.00	0.00	0.00	0.00	0.00	0.00	0.00	0.00	0.00	0.00	0.00
Clean electricity	0.00	0.00	0.00	0.00	0.00	0.00	0.00	0.01	0.00	0.00	0.00
Dirty electricity	-0.55	-0.14	-0.71	-0.72	-0.34	-0.12	-0.37	-0.18	-0.12	-0.27	-0.55
Clean heat	0.50	0.19	1.29	0.74	0.44	0.15	0.36	0.17	0.15	0.22	0.50
Dirty heat	-0.09	-0.10	-0.32	-0.18	-0.09	-0.02	-0.02	-0.03	-0.23	-0.12	-0.09

5.1.2.5 Italy

	GW	FE	ME	TE	AC	HT-C	HT-NC	ET	PM	AD-F	AD-E
Recycled paper	-0.38	-0.47	-0.54	-0.55	-0.23	-0.12	2.47	0.22	0.04	-0.33	-0.19
CG WtE plants	-0.01	0.00	-0.01	0.00	0.00	-0.08	0.13	-0.05	0.00	0.00	0.00
CG landfill	0.00	0.00	-0.01	-0.01	0.00	-0.01	0.01	-0.01	0.00	0.01	-0.01
CG compost plants	0.00	0.00	0.00	0.00	0.00	0.00	0.01	0.00	0.00	0.00	-0.04
CG AD plant	0.00	0.00	0.00	0.00	0.00	0.00	0.00	0.00	0.00	0.00	0.00
CG trucks	0.01	0.01	0.11	0.04	0.00	0.03	-0.14	0.11	0.01	0.01	0.05
Soil composting	0.00	0.00	-0.03	0.00	0.00	0.00	0.00	0.00	0.00	0.00	0.00
Clean electricity	-0.54	-0.08	-0.62	-0.52	-0.21	-0.03	0.29	-0.21	-0.12	-0.31	-0.34
Dirty electricity	0.21	-0.06	2.41	0.88	0.47	0.00	0.01	1.11	0.29	0.07	-0.30
Clean heat	-0.05	-0.01	-0.64	-0.24	-0.10	-0.01	0.24	-0.24	-0.07	-0.01	-0.14
Dirty heat	0.27	-0.01	1.84	0.67	0.36	0.00	0.08	0.69	0.22	0.11	-0.11

5.1.2.6 Poland

	GW	FE	ME	TE	AC	HT-C	HT-NC	ET	PM	AD-F	AD-E
Recycled paper	0.11	-0.35	0.06	0.29	-0.44	-0.09	0.40	-0.05	0.03	0.27	-0.40
CG landfill	-0.05	0.14	-0.01	-0.02	0.16	-0.04	-0.04	0.01	0.00	1.53	-0.44
CG compost plant	0.00	0.00	0.00	0.01	0.00	0.01	0.01	0.00	0.00	-0.02	-0.27
CG truck	0.03	0.02	0.01	0.06	-0.14	0.10	-0.02	-0.02	-0.02	-0.27	0.24
Soil composting	0.00	0.00	0.00	0.00	0.00	0.00	0.00	0.00	0.00	0.00	0.00
Clean electricity	0.13	-0.19	0.00	-0.09	-0.29	-0.08	-0.27	-0.03	-0.01	0.42	-0.03
Dirty electricity	-0.01	0.42	0.00	0.01	0.12	0.05	-0.02	0.01	0.02	1.72	-0.04
Clean heat	0.03	-0.01	0.01	0.04	-0.08	-0.02	0.02	0.01	-0.01	-0.24	0.00
Dirty heat	0.01	0.00	0.00	0.00	0.01	0.00	0.00	0.00	0.00	0.04	0.00

5.1.2.7 Greece

	GW	FE	ME	TE	AC	HT-C	HT-NC	ET	PM	AD-F	AD-E
Recycled paper	-0.05	0.25	-0.13	-2.75	0.29	0.07	-0.64	0.11	-0.04	0.43	0.22
CG landfill	0.00	0.00	0.00	0.01	0.00	0.00	0.00	0.00	0.00	0.00	0.00
CG truck	-0.01	0.00	-0.01	0.51	0.04	-0.03	0.01	0.02	0.02	0.03	-0.05
Soil composting	-0.01	0.00	-0.01	0.51	0.04	-0.03	0.01	0.02	0.02	0.03	-0.05
Clean electricity	-0.05	0.39	-0.06	-0.24	0.25	0.15	-0.10	-0.13	0.14	0.70	0.03
Dirty electricity	0.03	-0.45	0.04	-1.44	-0.17	-0.16	0.09	-0.03	-0.09	-0.65	0.02

5.2 Data quality and sensitivity

To determine the most relevant parameters, the results from data quality assessment and sensitivity analysis (perturbation and scenario analysis) were used together. Figure 16 shows a graphical presentation of the method: whenever a parameter sits into the red, yellow or green area, it means that it is very critical, critical or a little critical for the system.

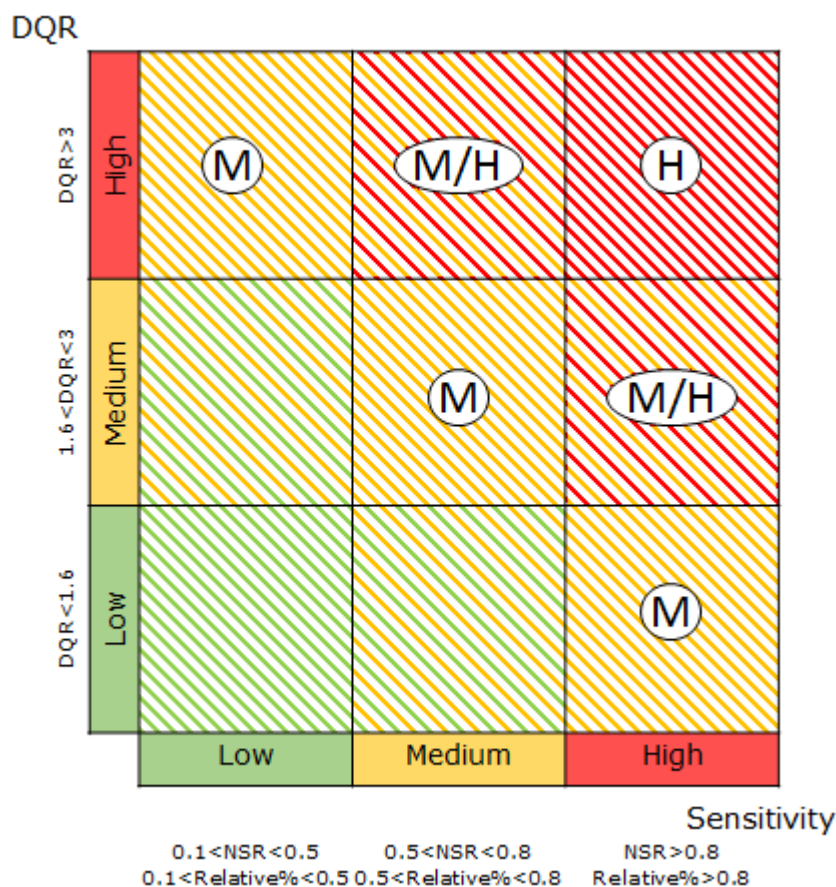

Figure 16: Graphic presentation of the method utilised to compare data quality and sensitivity, where DQR is the Data Quality Rating and NSR is the normalised sensitivity ratio. Whenever a parameter sits into the red, yellow or green area, it means that it is very critical, critical or a little critical for the system.

Following are the outcomes for each country and each impact category obtained by merging the results from the data quality assessment and the sensitivity analysis. The parameters classified as very critical (H) are highlighted in red, the parameters with a medium/high criticality in orange (M/H) and with a medium criticality in yellow (M) as shown in Table 101. To avoid confusion, parameter with low relevance were not highlighted. In general, the majority of the parameters show a medium data quality rating and a low or negligible sensitivity.

Table 101: Scale of colour to interpret the criticality of the parameters in the following paragraphs

H	High criticality
M/H	Medium/high criticality
M	Medium critically

However, aggregating in a qualitative way the results for all the countries and all the impact categories, some parameters can be highlighted as the most critical in the system:

- Emissions from the WtE plant for countries that utilise this technology
- Substitution ratio of paper and metals and glass
- Electricity and heat composition and material substituted by paper recycling.
- Gas utilization rates and infiltration rate in all the countries that consider landfilling of organic waste and oxidation rates for Poland and Greece
- Household sorting efficiencies, especially paper.

5.2.1 Germany

		GW 100	FE	ME	TE	AC	HT-C	HT- NC	ET	PM	AD-F	AD-E	
Household sorting	Sorting efficiency food												
	Sorting efficiency paper		M										
	Sorting efficiency cardboard												
	Sorting efficiency plastic bottles												
	Sorting efficiency hard plastic												
	Sorting efficiency soft plastic												
	Sorting efficiency glass												
	Sorting efficiency aluminium												
	Sorting efficiency steel												
Recycling	Substitution ratio paper		M/H	M/H	M	M		M	M		M/H	M	
	Substitution ratio cardboard			M					M			M/H	
	Substitution ratio PET												
	Substitution ratio HDPE												
	Substitution ratio soft plastic												
	Substitution ratio glass												
	Substitution ratio aluminium	M		M/H	M/H	M/H				M/H	M		
	Substitution ratio steel		M/H					M/H		M/H			M
	Emissions paper												
	Emissions glass												
	Emissions aluminium												
	Emissions steel								M/H				
	Electricity consumption paper												
	Electricity consumption PET												
	Electricity consumption HDPE												
	Electricity consumption soft plastic												
	Electricity consumption glass												
	Electricity consumption aluminium												
	Electricity consumption steel												
	Heat consumption PET												
	Heat consumption HDPE												
	Heat consumption soft plastic												
	Heat consumption glass												
	Heat consumption aluminium												
	Ancillary material paper												
	MBT	Transfer coefficient MBP_composting											
		Transfer coefficient MBP_RDF											
Transfer coefficient MBP_AI													
Transfer coefficient MBP_steel													
Transfer coefficient MBS_RDF													
Transfer coefficient MBS_AI													
Transfer coefficient MBS_steel													
WtE	Ancillary material												
	Electricity recovery efficiency		M/H								M/H	M	
	Heat recovery efficiency										M		
	% Steel recovered		M				M		M	M		M	
	% Al recovered	M		M	M	M				M	M		
	Process specific emissions			H	H								
	NOx in process specific emissions			H	H								
	SO2 in process specific emissions												
	Input specific emissions	H											
	CO2 fossil in input specific emissions	H											
Hg in input specific emissions													
Cu in input specific emissions													
Scenario	Transport										M		
	Recycled paper							M					
	CG WtE plant												
	CG landfill												
	CG composting plant												
	CG AD plant												
	CG truck												
	Soil composting												

5.2.2 Denmark

	GW 100	FE	ME	TE	AC	HT-C	HT-NC	ET	PM	AD-F	AD-E
Household sorting	Sorting efficiency food										
	Sorting efficiency paper		M/H			M	M/H	M	M	M	M
	Sorting efficiency cardboard										
	Sorting efficiency plastic bottles										
	Sorting efficiency hard plastic										
	Sorting efficiency soft plastic										
	Sorting efficiency glass										
	Sorting efficiency aluminium										
Sorting efficiency steel											
Recycling	Substitution ratio paper	M/H	M/H	M	M	M/H		M/H	M/H	M/H	M/H
	Substitution ratio cardboard										M
	Substitution ratio PET										
	Substitution ratio HDPE										
	Substitution ratio soft plastic										
	Substitution ratio glass								M		
	Substitution ratio aluminium					M			M		
	Substitution ratio steel						M/H		M		
	Emissions paper										
	Emissions glass										
	Emissions aluminium										
	Emissions steel										
	Electricity consumption paper										
	Electricity consumption PET										
	Electricity consumption HDPE										
	Electricity consumption soft plastic										
	Electricity consumption glass										
	Electricity consumption aluminium										
	Electricity consumption steel										
	Heat consumption PET										
	Heat consumption HDPE										
	Heat consumption soft plastic										
	Heat consumption glass										
Heat consumption aluminium											
Ancillary material paper											
WtE	Ancillary material										
	Electricity recovery efficiency	M									M
	Heat recovery efficiency	M/H		M	M	M		M	M/H	M/H	M/H
	% Steel recovered						M/H		M		
	% Al recovered										
	Process specific emissions										
	NOx in process specific emissions										
	SO2 in process specific emissions										
	Input specific emissions										
	CO2 fossil in input specific emissions										
Hg in input specific emissions											
Cu in input specific emissions											
Scenario	Transport										
	Recycled paper										
	CG WtE plant										
	CG landfill										
CG trucks											

5.2.3 France

	GW 100	FE	ME	TE	AC	HT-C	HT-NC	ET	PM	AD-F	AD-E	
Household sorting	Sorting efficiency food											
	Sorting efficiency paper		M/H			M		M	M	M	M	
	Sorting efficiency cardboard											
	Sorting efficiency plastic bottles											
	Sorting efficiency hard plastic											
	Sorting efficiency soft plastic											
	Sorting efficiency glass								M			
	Sorting efficiency aluminium											
Sorting efficiency steel												
Recycling	Substitution ratio paper		M/H	M		M/H		M/H	M	M	M/H	M/H
	Substitution ratio cardboard								M			M/H
	Substitution ratio PET											
	Substitution ratio HDPE											
	Substitution ratio soft plastic											
	Substitution ratio glass					M/H				M/H		
	Substitution ratio aluminium					M						
	Substitution ratio steel		M				M/H		M/H			M
	Emissions paper											
	Emissions glass					M						
	Emissions aluminium											
	Emissions steel							M/H				
	Electricity consumption paper											
	Electricity consumption PET											
	Electricity consumption HDPE											
	Electricity consumption soft plastic											
	Electricity consumption glass											
	Electricity consumption aluminium											
	Electricity consumption steel											
	Heat consumption PET											
	Heat consumption HDPE											
	Heat consumption soft plastic											
	Heat consumption glass					M					M	
Heat consumption aluminium												
Ancillary material paper												
WtE	Ancillary material											
	Electricity recovery efficiency											
	Heat recovery efficiency									M		
	% Steel recovered		M/H				M/H		M/H	M		M
	% Al recovered			M	M	M/H				M	M	
	Process specific emissions			H	H	M/H						
	NOx in process specific emissions			H	H	M/H						
	SO2 in process specific emissions											
	Input specific emissions	H										
	CO2 fossil in input specific efficiency	H										
Hg in input specific efficiency												
Cu in input specific emissions												
Landfill	Oxidation in top cover, daily											
	Oxidation in top cover, intermediate											
	Oxidation in top cover, final											
	Gas collected	M										
	Gas utilised											
	Net thermal efficiency, electricity											
	Net thermal efficiency, heat											
	Infiltration rate								M			
C storage												
Scenario	Transport									M		
	Recycled paper	M										
	CG WtE plant							M				
	CG landfill							M/H				
	CG composting plant											
	CG trucks											
Soil composting												

5.2.4 UK

		GW 100	FE	ME	TE	AC	HT-C	HT-NC	ET	PM	AD-F	AD-E
Household sorting	Sorting efficiency food											
	Sorting efficiency paper		M/H	M	M	M		M/H	M/H	M	M	M
	Sorting efficiency cardboard											
	Sorting efficiency plastic bottles											
	Sorting efficiency hard plastic											
	Sorting efficiency soft plastic											
	Sorting efficiency glass									M		
	Sorting efficiency aluminium											
	Sorting efficiency steel											
Recycling	Substitution ratio paper	M	M/H	M/H	M/H	M/H		M/H	M/H	M/H	M/H	M/H
	Substitution ratio cardboard											M
	Substitution ratio PET											
	Substitution ratio HDPE											
	Substitution ratio soft plastic											
	Substitution ratio glass									M/H		
	Substitution ratio aluminium					M				M		
	Substitution ratio steel						M/H		M			
	Emissions paper											
	Emissions glass											
	Emissions aluminium											
	Emissions steel							M				
	Electricity consumption paper											
	Electricity consumption PET											
	Electricity consumption HDPE											
	Electricity consumption soft pl											
	Electricity consumption glass											
	Electricity consumption aluminium											
	Electricity consumption steel											
	Heat consumption PET											
	Heat consumption HDPE											
	Heat consumption soft plastic											
	Heat consumption glass											
	Heat consumption aluminium											
	Ancillary material paper											
	WtE	Ancillary material					M					
Electricity recovery eff												
Heat recovery eff										M/H	M	
% Steel recovered			M				M/H		M			
% Al recovered						M				M		
Process specific emissions				M/H	M/H							
NOx in process specific emissions				M/H	M/H							
SO2 in process specific emissions												
Input specific emissions		M/H										
CO2 fossil in input specific emissions		M/H										
Hg in input specific emissions												
Cu in input specific emissions												
Landfill	Oxidation in top cover, daily											
	Oxidation in top cover, intermediate											
	Oxidation in top cover, final											
	Gas collected	M/H										
	Gas utilised											
	Net thermal efficiency, electricity											
	Net thermal efficiency, heat											
	Infiltration rate								M			
	C storage											
Scenario	Transport											
	Recycled paper											
	CG WtE plant											
	CG landfill											
	CG composting plant											
	CG trucks											
	Soil composting											

5.2.5 Italy

		GW 100	FE	ME	TE	AC	HT-C	HT-NC	ET	PM	AD-F	AD-E
Household sorting	Sorting efficiency food							M	M			
	Sorting efficiency paper		M/H	M	M			M/H	M/H	M	M	M
	Sorting efficiency cardboard											
	Sorting efficiency plastic bottles											
	Sorting efficiency hard plastic											
	Sorting efficiency soft plastic											
	Sorting efficiency glass											
	Sorting efficiency aluminium											
Sorting efficiency steel												
Recycling	Substitution ratio paper	M/H	M/H	M/H	M/H	M		M/H	M/H	M	M/H	M/H
	Substitution ratio cardboard								M			M/H
	Substitution ratio PET											
	Substitution ratio HDPE											
	Substitution ratio soft plastic											
	Substitution ratio glass			M	M						M/H	
	Substitution ratio aluminium	M		M/H	M/H	M/H					M/H	
	Substitution ratio steel		M					M/H		M/H		
	Emissions paper											
	Emissions glass				M							
	Emissions aluminium											
	Emissions steel								M/H			
	Electricity consumption paper											
	Electricity consumption PET											
	Electricity consumption HDPE											
	Electricity consumption soft plastic											
	Electricity consumption glass											
	Electricity consumption aluminium											
	Electricity consumption steel											
	Heat consumption PET											
Heat consumption HDPE												
Heat consumption soft plastic												
Heat consumption glass												
Heat consumption aluminium												
Ancillary material paper												
MBT	Transfer coefficient MBP_composting											
	Transfer coefficient MBP_RDF					M			M	M	M	M
	Transfer coefficient MBP_Al	M		M	M	M				M		
	Transfer coefficient MBP_steel						M	M				
WtE	Ancillary material											
	Electricity recovery eff	M		M	M						M	M
	Heat recovery eff											
	% Steel recovered		M				M/H		M			M
	% Al recovered	M		M	M	M				M	M	
	Process specific emissions			H	H							
	NOx in process specific emissions			H	H							
	SO2 in process specific emissions											
	Input specific emissions	H										
	CO2 fossil in input specific emissions	H										
Hg in input specific emissions												
Cu in input specific emissions												
Landfill	Oxidation in top cover, daily											
	Oxidation in top cover, intermediate											
	Oxidation in top cover, final											
	Gas collected	H										
	Gas utilised											
	Net thermal efficiency, electricity											
	Net thermal efficiency, heat											
	Infiltration rate								M			
C storage	M/H											
Scenario	Transport										M	
	Recycled paper							M				
	CG WtE plants											
	CG landfill											
	CG compost plants											
	CG AD plant											
	CG trucks											
Soil composting												

5.2.6 Poland

		GW 100	FE	ME	TE	AC	HT-C	HT- NC	ET	PM	AD-F	AD-E
Household sorting	Sorting efficiency food							M				
	Sorting efficiency paper							M				M
	Sorting efficiency cardboard											
	Sorting efficiency plastic bottles											
	Sorting efficiency hard plastic											
	Sorting efficiency soft plastic											
	Sorting efficiency glass									M		
	Sorting efficiency aluminium											
Sorting efficiency steel												
Recycling	Substitution ratio paper							M				M/H
	Substitution ratio cardboard											M/H
	Substitution ratio PET											
	Substitution ratio HDPE											
	Substitution ratio soft plastic											
	Substitution ratio glass				M/H	M/H				M/H		M/H
	Substitution ratio aluminium											
	Substitution ratio steel						M/H					M
	Emissions paper											
	Emissions glass				M/H	M						
	Emissions aluminium											
	Emissions steel							M/H				
	Electricity consumption paper											
	Electricity consumption PET											
	Electricity consumption HDPE											
	Electricity consumption soft plastic											
	Electricity consumption glass											
	Electricity consumption aluminium											
	Electricity consumption steel											
	Heat consumption PET											
Heat consumption HDPE												
Heat consumption soft plastic												
Heat consumption glass				M	M						M	
Heat consumption aluminium												
Ancillary material paper												
MBT	Transfer coefficient MBP_composting											
	Transfer coefficient MBP_RDF											
	Transfer coefficient MBP_Al					M						
	Transfer coefficient MBP_steel						M/H	M/H				M
Landfill	Oxidation in top cover, daily											
	Oxidation in top cover, intermediate											
	Oxidation in top cover, final											
	Gas collected	H	M		M	M	M	M				M
	Gas utilised		M/H			M/H	M	M				M/H
	Net thermal efficiency, electricity		M		M	M	M	M				M
	Net thermal efficiency, heat											
	Infiltration rate				M/H					M/H		
C storage	M/H											
Scenario	Transport											M/H
	Recycled paper											
	CG landfill											M/H
	CG compost plant											
	CG truck											
Soil composting												

5.2.7 Greece

		GW 100	FE	ME	TE	AC	HT-C	HT-NC	ET	PM	AD-F	AD-E	
Household sorting	Sorting efficiency food												
	Sorting efficiency paper				M					M		M	
	Sorting efficiency cardboard												
	Sorting efficiency plastic bottles												
	Sorting efficiency hard plastic												
	Sorting efficiency soft plastic												
	Sorting efficiency glass												
	Sorting efficiency aluminium				M/H	M/H				M/H			
Sorting efficiency steel							M/H	M/H		M		M	
Recycling	Substitution ratio paper				M/H	M				M		M/H	
	Substitution ratio cardboard												
	Substitution ratio PET												
	Substitution ratio HDPE												
	Substitution ratio soft plastic												
	Substitution ratio glass									M			
	Substitution ratio aluminium				M/H	M/H				M/H			
	Substitution ratio steel							M/H			M		M/H
	Emissions paper												
	Emissions glass												
	Emissions aluminium												
	Emissions steel								M/H				
	Electricity consumption paper												
	Electricity consumption PET												
	Electricity consumption HDPE												
	Electricity consumption soft plastic												
	Electricity consumption glass												
	Electricity consumption aluminium												
	Electricity consumption steel												
	Heat consumption PET												
Heat consumption HDPE													
Heat consumption soft plastic													
Heat consumption glass													
Heat consumption aluminium													
Ancillary material paper													
Landfill	Oxidation in top cover, daily												
	Oxidation in top cover, intermediate												
	Oxidation in top cover, final												
	Gas collected	M/H	M		M	M	M			M	M		
	Gas utilised		M/H		M	M/H	M			M/H	M/H		
	Net thermal efficiency, electricity		M		M	M	M			M	M		
	Net thermal efficiency, heat												
	Infiltration rate			M/H						M/H			
C storage	M/H												
Scenario	Transport												
	Recycled paper				M								
	CG landfill												
	CG trucks				M								

5.3 Comparison with the European Waste Hierarchy

Waste Hierarchy is a simple tool that has been used in European legislation to drive the technologies that are considered most environmental friendly. Since this paper does not include prevention and reuse, the environmental impacts are compared to recycling percentages in order to answer to the question: is there a linear correlation between environmental impacts and recycling percentages? Three different percentages are tested and all include material recycling, composting and anaerobic digestion: recycling rate of municipal waste in 2013 reported by Eurostat (Eurostat, 2016), recycling rate of household waste modelled in this paper (including material recycling from WtE and MBT plants) and effective recycling rate calculated by considering recycling efficiencies (Table 102). Figure 17-Figure 27 show the relations between recycling percentages and mPE in each impact categories. While there is a great improvement going from Greece to Germany, it is not clear which the main driving force is. In conclusion, waste hierarchy appears to be a very simplified tool to drive waste flows because it does not consider the national context. Particularly, waste and energy composition can affect the overall ranking. Incineration leads to high environmental savings only in case of high efficiency and of fossil sources substitution. Waste management should focus more on quality of materials collected and on what material and energy recovery actually substitute.

Table 102: Recycling percentages for Germany (DE), Denmark (DK), France (FR), United Kingdom (UK), Italy (IT), Poland (PL) and Greece (EL)

	DE	DK	UK	IT	FR	PL	EL
% recycling for EU 2013	64%	44%	43%	39%	39%	24%	19%
% recycling article	55%	41%	32%	28%	26%	13%	8%
% effective recycling article	48%	37%	28%	26%	24%	10%	6%

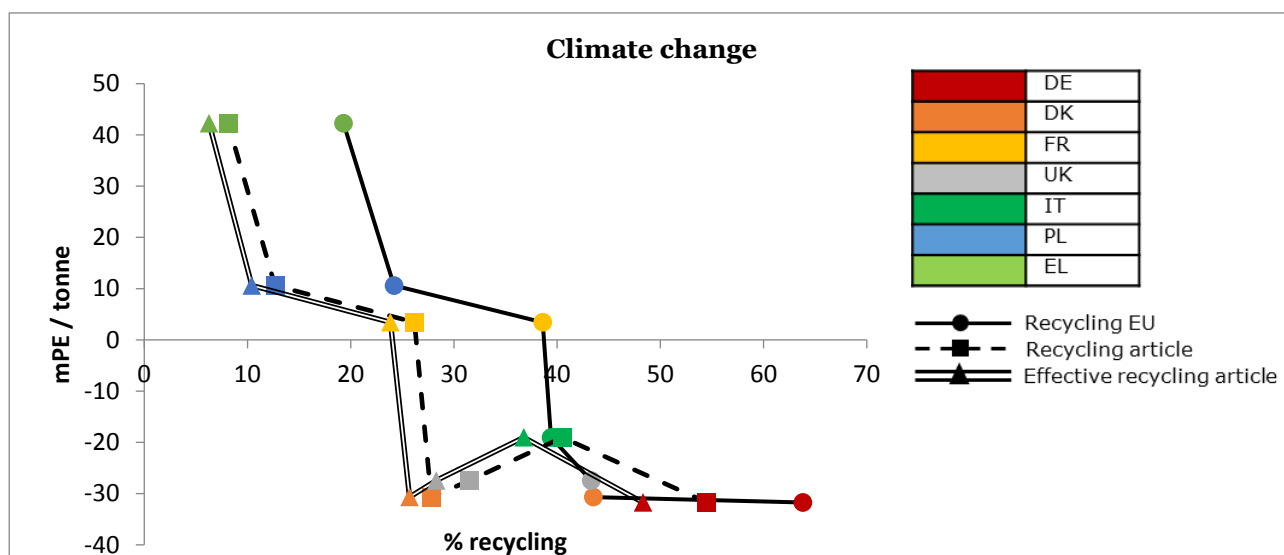

Figure 17: graphical relations between recycling percentages and milli-Person Equivalent (mPE) in Climate Change for Germany (DE), Denmark (DK), France (FR), United Kingdom (UK), Italy (IT), Poland (PL) and Greece (EL).

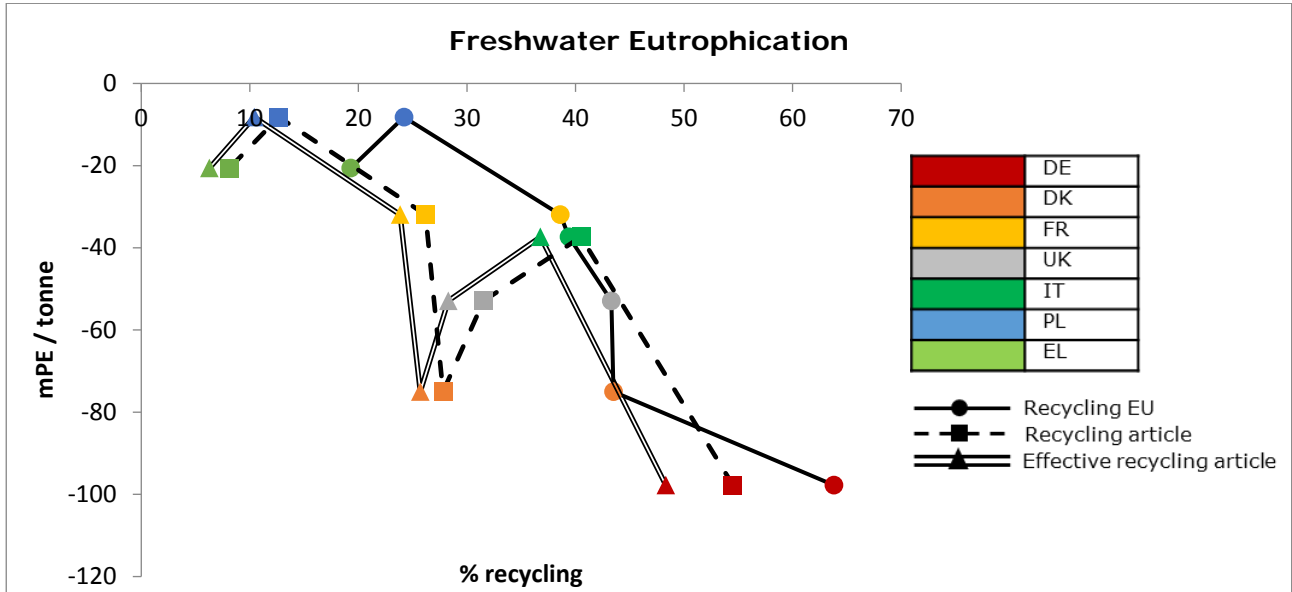

Figure 18 graphical relations between recycling percentages and milli-Person Equivalent (mPE) in Freshwater Eutrophication for Germany (DE), Denmark (DK), France (FR), United Kingdom (UK), Italy (IT), Poland (PL) and Greece (EL).

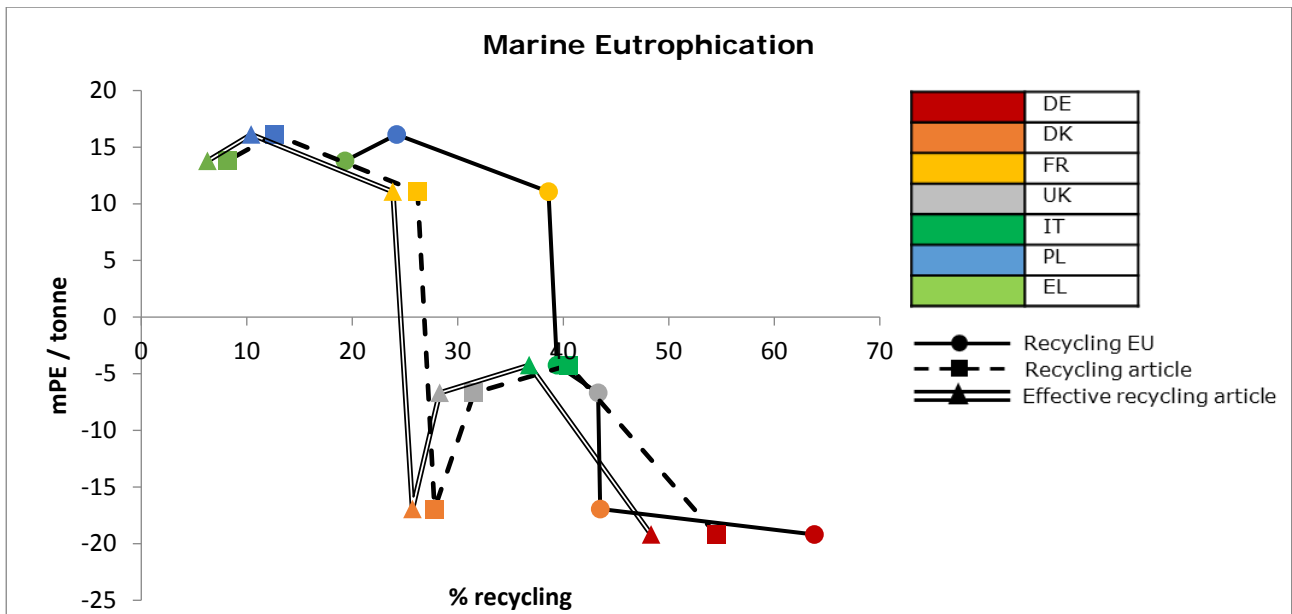

Figure 19: graphical relations between recycling percentages and milli-Person Equivalent (mPE) in Marine Eutrophication for Germany (DE), Denmark (DK), France (FR), United Kingdom (UK), Italy (IT), Poland (PL) and Greece (EL).

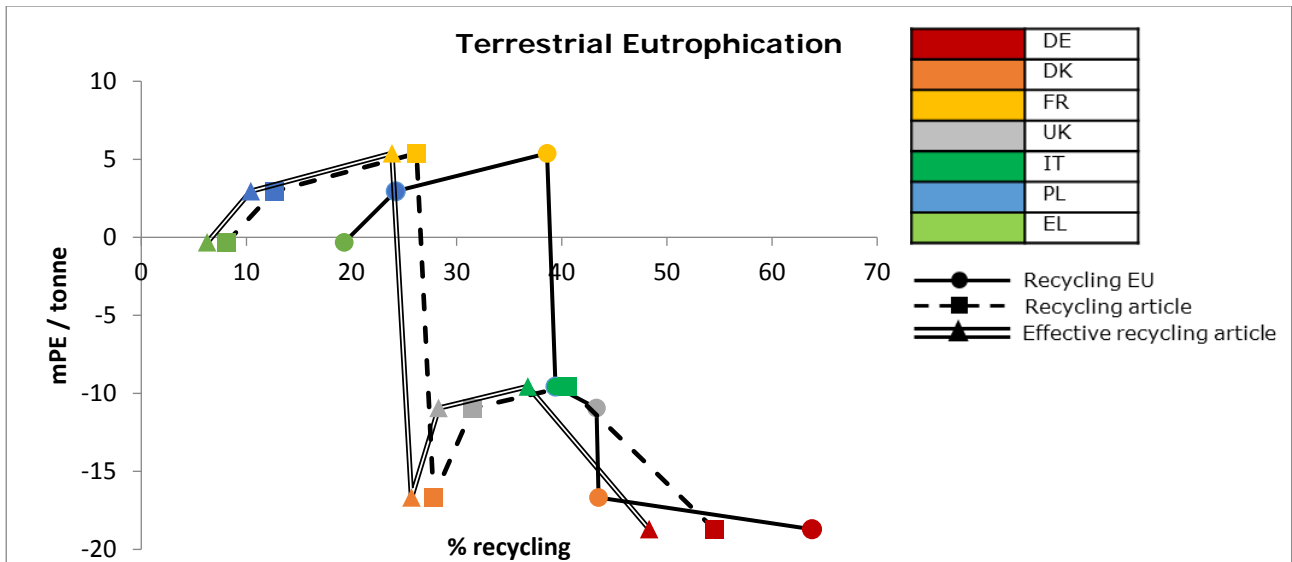

Figure 20: graphical relations between recycling percentages and milli-Person Equivalent (mPE) in Terrestrial Eutrophication for Germany (DE), Denmark (DK), France (FR), United Kingdom (UK), Italy (IT), Poland (PL) and Greece (EL).

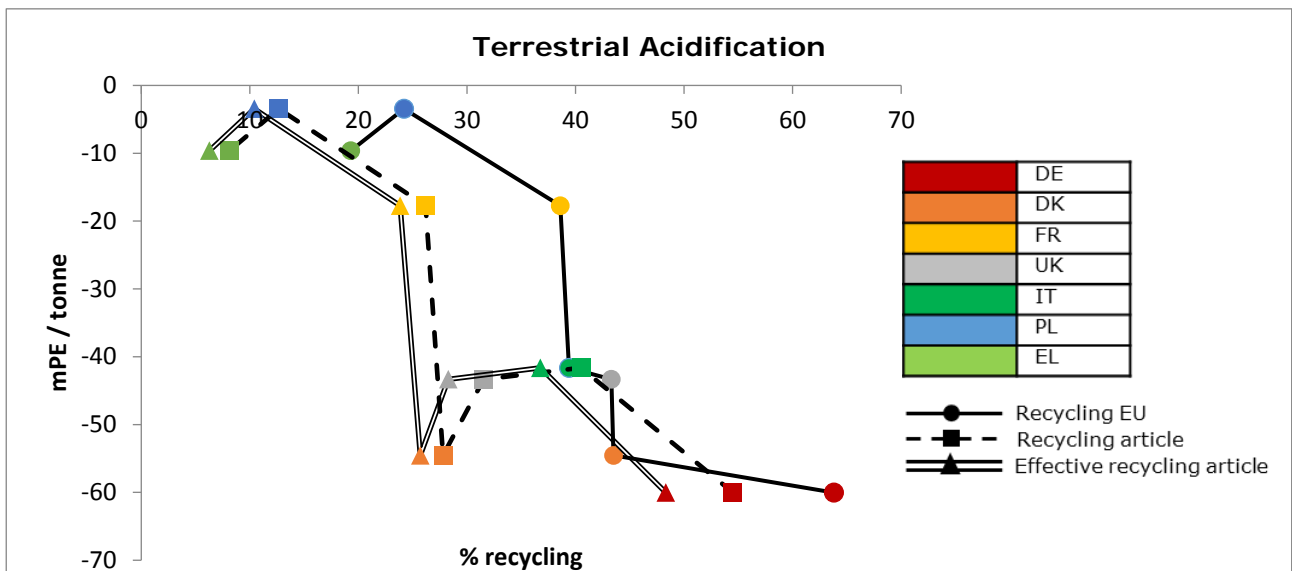

Figure 21: graphical relations between recycling percentages and milli-Person Equivalent (mPE) in Terrestrial Acidification for Germany (DE), Denmark (DK), France (FR), United Kingdom (UK), Italy (IT), Poland (PL) and Greece (EL).

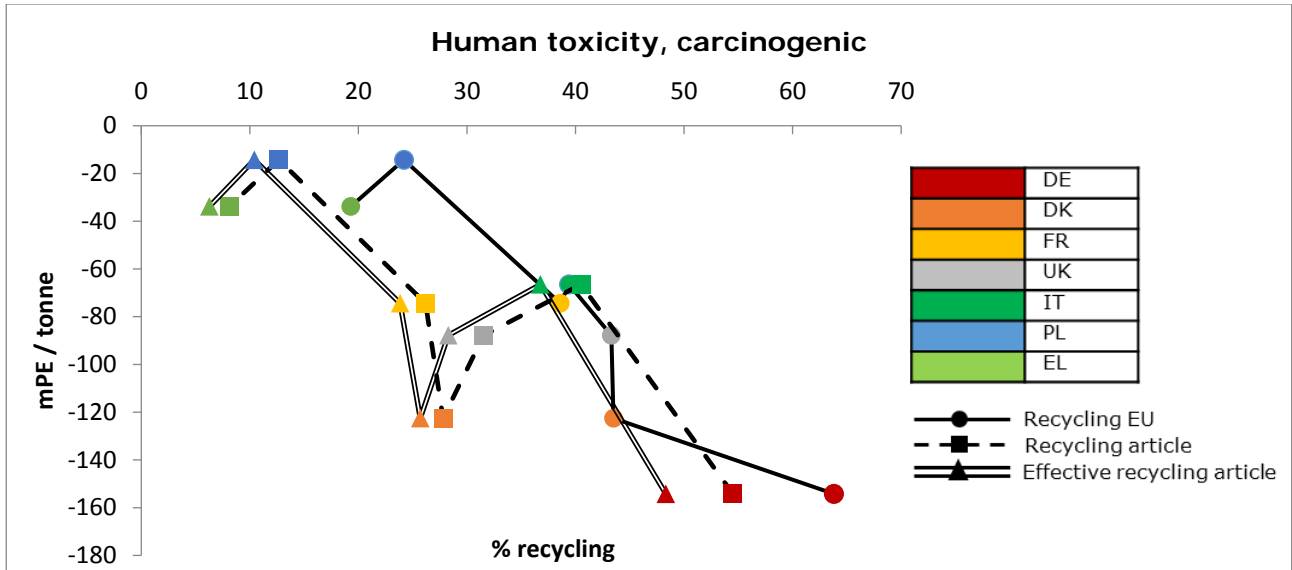

Figure 22: graphical relations between recycling percentages and milli-Person Equivalent (mPE) in Human Toxicity-carcinogenic for Germany (DE), Denmark (DK), France (FR), United Kingdom (UK), Italy (IT), Poland (PL) and Greece (EL).

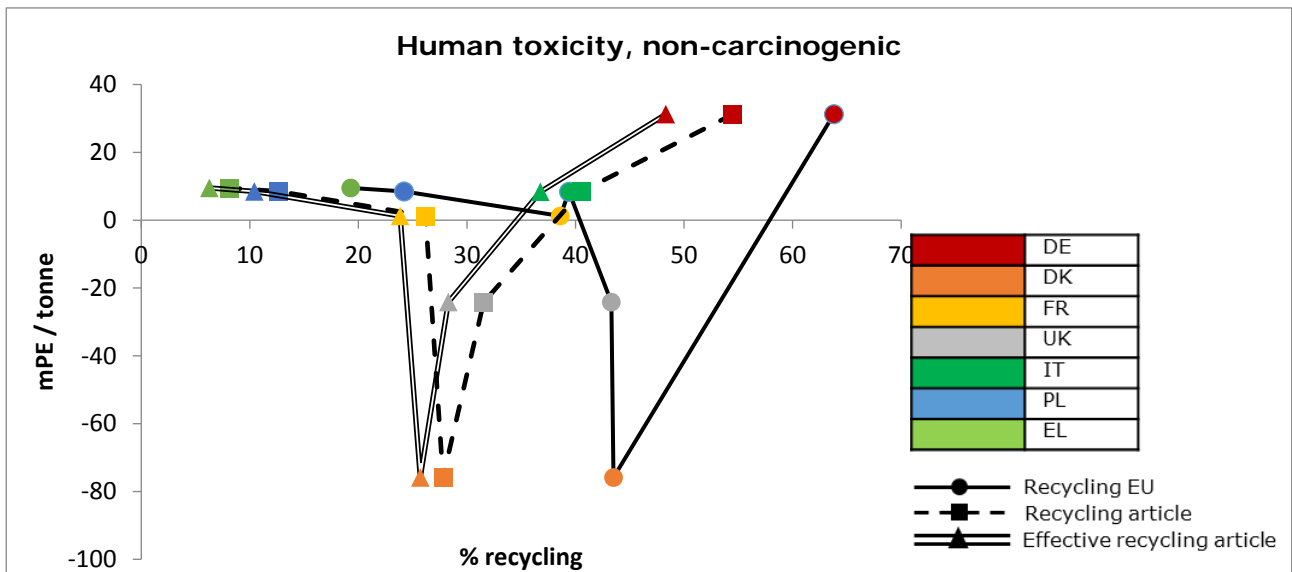

Figure 23: graphical relations between recycling percentages and milli-Person Equivalent (mPE) in Human Toxicity-carcinogenic for Germany (DE), Denmark (DK), France (FR), United Kingdom (UK), Italy (IT), Poland (PL) and Greece (EL).

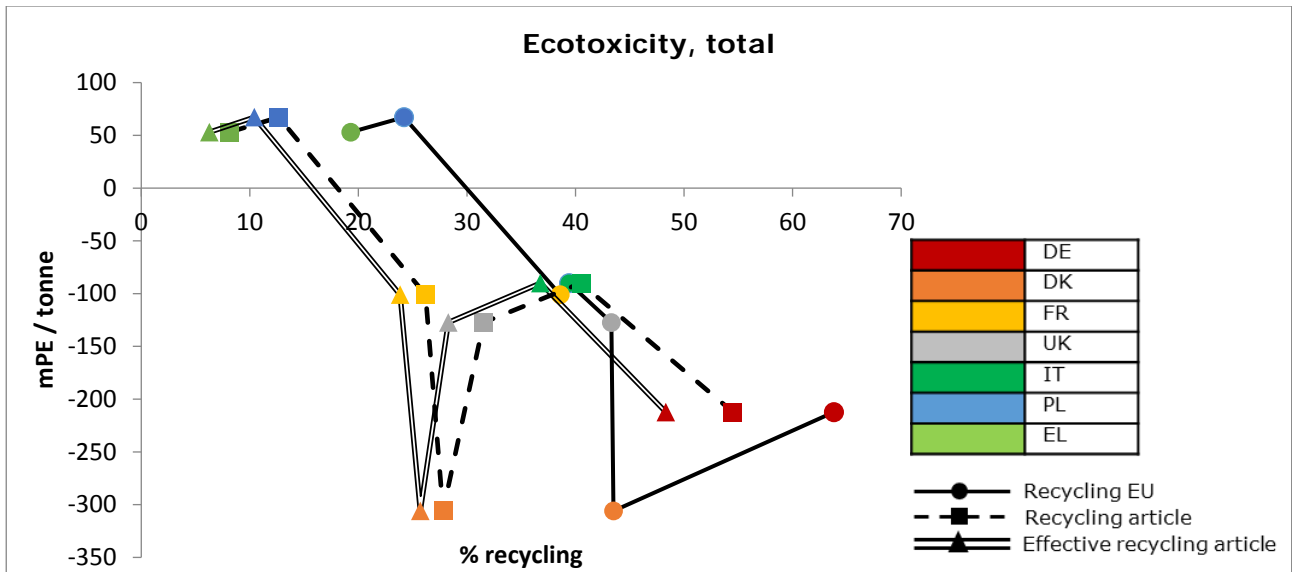

Figure 24: graphical relations between recycling percentages and milli-Person Equivalent (mPE) in Ecotoxicity-total for Germany (DE), Denmark (DK), France (FR), United Kingdom (UK), Italy (IT), Poland (PL) and Greece (EL).

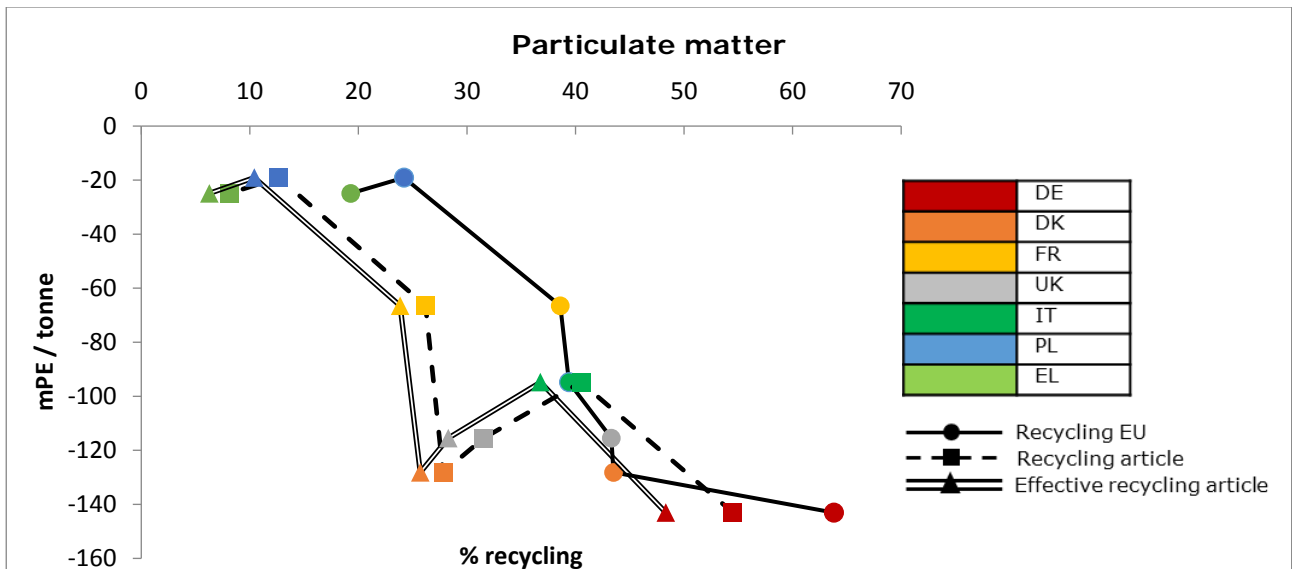

Figure 25: graphical relations between recycling percentages and milli-Person Equivalent (mPE) in Particulate Matter for Germany (DE), Denmark (DK), France (FR), United Kingdom (UK), Italy (IT), Poland (PL) and Greece (EL).

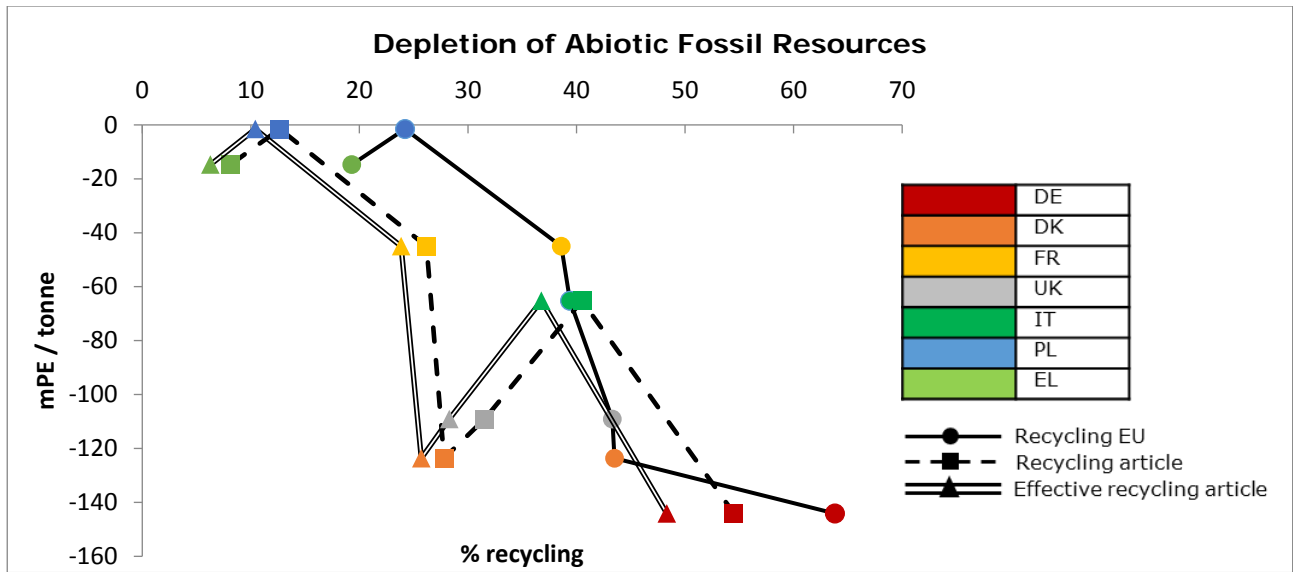

Figure 26: graphical relations between recycling percentages and milli-Person Equivalent (mPE) in Depletion of Abiotic Fossil Resources for Germany (DE), Denmark (DK), France (FR), United Kingdom (UK), Italy (IT), Poland (PL) and Greece (EL).

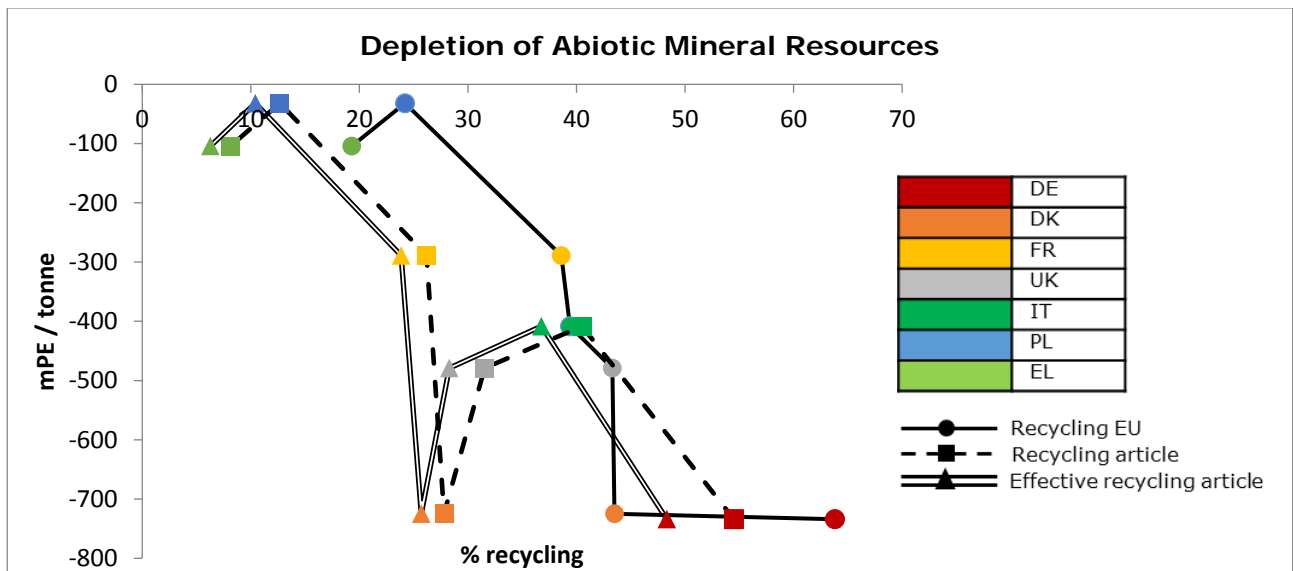

Figure 27: graphical relations between recycling percentages and milli-Person Equivalent (mPE) in Depletion of Abiotic Mineral Resources for Germany (DE), Denmark (DK), France (FR), United Kingdom (UK), Italy (IT), Poland (PL) and Greece (EL).

6 Bibliography

- ADEME, 2013. État de l'art de la collecte séparée et de la gestion de proximité des biodéchets - Partie 2 : Fiches pays, France [in French]. Paris.
- ADEME, 2011. La collecte des déchets par le service public en France - Résultats 2011 [in French]. Paris.
- ADEME, 2010a. La composition des ordures ménagères et assimilées en France. ADEME, Paris.
- ADEME, 2010b. ITOM : Les installations de traitement des ordures ménagères en France - résultats 2010 [in French]. ADEME.
- ADEME, Eco-Emballages et Ecofolio, 2014. Étude de l'adaptabilité des centres de tri des Déchets Ménagers aux évolutions potentielles des collectes séparées; Version 2 [in French].
- Althaus, H., Hirschier, R., Osses, M., Primas, A., Hellweg, S., Jungbluth, N., Chudacoff, M., 2007. Life cycle inventories of chemicals. Data v2.0 (2007), ecoinvent report No.8. Dübendorf.
- Ancitel Energia e Ambiente S.r.l., 2012. La Banca Dati - 2° rapport Raccolta Differenziata 2011 [in Italian]. Rome.
- Andersen, J.K., Christensen, T.H., Scheutz, C., 2010. Substitution of peat, fertiliser and manure by compost in hobby gardening: User surveys and case studies. *Waste Manag.* 30, 2483–2489. doi:10.1016/j.wasman.2010.07.011
- Andreasi Bassi, S., 2015. Interview to Christian Riber.
- Anthouli, A., Aravossis, K., Charitopoulou, R., Tot, B., Vujic, G., 2013. Opportunities & barriers of recycling in Balkan countries: the cases of Greece and Serbia. HSWMA, SeSWA, and ISWA.
- Bakas, I. (Copenhagen R.I.), Milios, L. (Copenhagen R.I.), 2013. Municipal waste management in Greece - report prepared for the European Environmental Agency (EEA). European Environment Agency (EEA).
- Birgisdóttir, H., Bhandar, G., Hauschild, M.Z., Christensen, T.H., 2007. Life cycle assessment of disposal of residues from municipal solid waste incineration: Recycling of bottom ash in road construction or landfilling in Denmark evaluated in the ROAD-RES model. *Waste Manag.* 27, 75–84. doi:10.1016/j.wasman.2007.02.016
- Boer, E. Den, Jedrczak, A., Kowalski, Z., Kulczycka, J., Szpadt, R., 2010. A review of municipal solid waste composition and quantities in Poland. *Waste Manag.* 30, 369–377. doi:10.1016/j.wasman.2009.09.018
- Boldrin, A., Christensen, T.H., Körner, I., Krogmann, U., 2011. Composting: Mass Balances and Product Quality, in: *Solid Waste Technology & Management*. Blackwell Publishing Ltd., pp. 569–582. doi:10.1002/9780470666883.ch36
- Boldrin, A., Damgaard, A., Brogaard, L.K.-S., Astrup, T.F., 2014. Life Cycle assessment of shredder residue management.
- Boldrin, A., Hartling, K.R., Laugen, M., Christensen, T.H., 2010. Environmental inventory modelling of the use of compost and peat in growth media preparation. *Resour. Conserv. Recycl.* 54, 1250–1260. doi:10.1016/j.resconrec.2010.04.003
- Brogaard, L.K.-S., Christensen, T.H., 2016. Life cycle assessment of capital goods for waste management systems, Submitted to the journal "Waste Management." Kongens Lyngby, Denmark.
- Brogaard, L.K., Damgaard, A., Jensen, M.B., Barlaz, M., Christensen, T.H., 2014. Evaluation of life cycle inventory data for recycling systems. *Resour. Conserv. Recycl.* 87, 30–45.
- Brogaard, L.K., Petersen, P.H., Nielsen, P.D., Christensen, T.H., 2015. Quantifying capital goods for biological treatment of organic waste. *Waste Manag. Res.* 33, 96–106. doi:10.1177/0734242X14565212
- Brogaard, L.K., Riber, C., Christensen, T.H., 2013. Quantifying capital goods for waste incineration. *Waste Manag.* 33, 1390–1396. doi:10.1016/j.wasman.2013.03.007
- Central Statistical Office, 2013. Municipal Infrastructure in 2012. Warsaw.
- CEPI - Confederation of European Paper Industries, 2013. Key Statistics - European Pulp and Paper industry, 2013. CEPI 2–11.
- Christensen, T.H., 2011. Introduction to Waste Management, in: Christensen, T.H. (Ed.), *Solid Waste Technology & Management*. Blackwell Publishing Ltd., p. 15.
- Christensen, T.H., Fruergaard, T., Matsufuji, Y., 2011. Residential Waste, in: Christensen, T.H. (Ed.), *Solid Waste Technology & Management*. Blackwell Publishing Ltd., pp. 85–96.
- Classen, M., Althaus, H.-J., Blaser, S., Scharnhorst, W., Tuchschnid, M., Jungbluth, N., Emmenegger, M., 2009. Life Cycle Inventories of Metals Data v2.1 (2009), ecoinvent v2.1 report No. 10. Dübendorf. doi:10.1065/lca2004.11.181.5
- Clavreul, J., Baumeister, H., Christensen, T.H., Damgaard, A., 2014. An environmental assessment system for

- environmental technologies. *Environ. Model. Softw.* 60, 18–30. doi:10.1016/j.envsoft.2014.06.007
- Clavreul, J., Guyonnet, D., Christensen, T.H., 2012. Quantifying uncertainty in LCA-modelling of waste management systems. *Waste Manag.* 32, 2482–2495. doi:10.1016/j.wasman.2012.07.008
- Defra, 2014. Local Authority Collected Waste Statistics - Local Authority data.
- DEFRA, 2014a. Local Authority Collected Waste Statistics - England - Waste from Households.
- DEFRA, 2014b. Average outflow and total rainfall for England: 1961 to 2013 [WWW Document]. URL https://www.gov.uk/government/uploads/system/uploads/attachment_data/file/384099/England_Rainfall_Outflow_2014.csv/preview (accessed 7.16.15).
- Doka, G., 2009. Life Cycle Inventories of Waste Treatment Services. Part II “Waste incineration,” Ecoinvent report No. 13. St. Gallen.
- DTU Environment, 2017. MBT model. Internal report.
- EC-JRC, 2011. International Reference Life Cycle Data System (ILCD) Handbook- Recommendations for Life Cycle Impact Assessment in the European context. Publications Office of the European Union, Luxemburg. doi:10.278/33030
- EC-JRC, 2010. International Reference Life Cycle Data System (ILCD) Handbook - General guide for Life Cycle Assessment - Detailed guidance. Publications Office of the European Union, Luxembourg. doi:10.2788/38479
- ecoinvent, 2016. Swiss life cycle inventory database [WWW Document]. URL <http://www.ecoinvent.org/login-databases.html>
- Economopoulos, A.P., 2010. Technoeconomic aspects of alternative municipal solid wastes treatment methods. *Waste Manag.* 30, 707–715. doi:10.1016/j.wasman.2009.11.004
- Edjabou, M.E., Jensen, M.B., Götze, R., Pivnenko, K., Petersen, C., Scheutz, C., Astrup, T.F., 2015. Municipal solid waste composition: Sampling methodology, statistical analyses, and case study evaluation. *Waste Manag.* 36, 12–23. doi:10.1016/j.wasman.2014.11.009
- Environment Food and Rural Affairs Committee - Parliament UK, 2014. Recycling rates in England [WWW Document]. URL <http://www.publications.parliament.uk/pa/cm201415/cmselect/cmenvfru/241/24106.htm#note49> (accessed 10.22.14).
- EPEM – Environmental and Planning Engineering and Management S.A., 2014. LIFE09 ENV/GR/000294 Waste Management Options for Greenhouse Gases Emissions Control Midterm Report / Annex 7.3.6: Reference case for the Region of Eastern Macedonia and Thrace (REMTH) [WWW Document]. URL http://www.epem.gr/waste-control/pdf/reference_case_REMTH.pdf (accessed 6.13.15).
- EUROCONSULTANTS, EPTA, 2010. Final Report - Part 1 Analysis of Solid Waste Management in Greece - JESSICA Instruments for Solid Waste Management in Greece.
- Eurostat, 2016. Recycling rate of municipal solid waste [WWW Document]. URL http://ec.europa.eu/eurostat/tgm/table.do?tab=table&init=1&plugin=1&language=en&code=t2020_rt120 (accessed 4.6.16).
- Eurostat, 2014. Municipal waste treated in 2012 by country and treatment category sorted by percentage 2012 [WWW Document]. URL http://ec.europa.eu/eurostat/statistics-explained/index.php?title=File:Municipal_waste_treated_in_2012_by_country_and_treatment_category_sorted_by_percentage_2012_new.PNG&oldid=176349 (accessed 7.26.15).
- Eurostat, 2013. Electricity and heat statistics, 2013.
- Ezeah, C., Byrne, T., 2014. A Critical Review of Municipal Solid Waste Legislation and Compliance in Greece- In the Context of the EU Landfill Directive. *IOSR J. Environ. Sci. Toxicol. Food Technol.* 8, 81–89.
- Fischer, C., 2013. Municipal waste management in Poland. European Environment Agency (EEA).
- Fondazione Sviluppo Sostenibile, 2014. Frazione organica e fanghi [in Italian], in: *L'Italia Del Riciclo 2014*. pp. 170–175.
- Franklin Associates, 2011. Life cycle inventory of 100% postconsumer HDPE and PET recycled resin from postconsumer containers and packaging. Prepared for The Plastics Division of the American Chemistry Council; The Association of Postconsumer Plastic Recyclers, The National Associat. Kansas. doi:10.1017/CBO9781107415324.004
- GIB Gesellschaft für Innovationsforschung und Beratung mbH Berlin, 2009. Endbericht -Die wirtschaftliche Bedeutung der Recycling und Entsorgungsbranche in Deutschland - Stand , Hemmnisse , Herausforderungen for Bundesministeriums für Wirtschaft und Technologie (in German).
- Gibbs, A., Elliott, T., Vergunst, T., Ballinger, A., Hogg, D., Gentil, A., Fischer, C., Bakas, I., Ryberg, M., 2014. “Development of a Modelling Tool on Waste Generation and Management” Appendix 1: Baseline Report. Final Report for the European Commission DG Environment under Framework Contract No ENV.C.2/FRA/2011/0020 Authors :

- Głównego Urzędu Statystycznego - Central Statistical Office in Warsaw, 2014. Ochrona Środowiska 2014 - Environment 2014.
- Głównego Urzędu Statystycznego - Central Statistical Office in Warsaw, 2013. Ochrona Środowiska 2013 - Environment 2013.
- Hischier, R., 2007a. Packaging glass, Life Cycle Inventories of Packagings and Graphical Papers. Ecoinvent-Report No. 11. Dübendorf.
- Hischier, R., 2007b. Life Cycle Inventories of Packaging and Graphical Papers. Data v2.0 (2007) Ecoinvent Report No. 11. St. Gallen.
- International Aluminium Institute, 2007. Life Cycle Assessment Of Aluminium: Inventory Data For The Primary Aluminium Industry Year 2005 Update.
- International Energy Agency Bioenergy, 2015. IEA Bioenergy Task 37 Country Reports Summary 2014. IEA Bioenergy.
- ISPRA, 2014. Rapporto Rifiuti Urbani - Edizioni 2014, Dati di sintesi [in Italian]. Rome.
- Jansen, M., Feil, A., Pretz, T., 2012. Recovery of Plastics from Household Waste by Mechanical Separation, in: Thomé-Kozmiensky, K.J., Thiel, S. (Eds.), Waste Management, Volume 3. pp. 169–176.
- Jungbluth, N., Emmenegger, M.F., Dinkel, F., Stettler, C., Doka, G., Chudacoff, M., 2007. Life cycle inventories of bioenergy. Data v2.0 (2007), Ecoinvent report No.17. Uster.
- Kühle-Weidemeier, M., Langer, D.U., Hohmann, F., 2007. Plants for Mechanical-Biological Waste Treatment - Summary of the final report. Environ. Res. Progr. Fed. Minist. Environ. Environ. Prot. Nucl. Safety. Waste Manag. Found. Number 206 33 301.
- Land Quality Management, L., 2003. Methane Emissions from Landfill Sites in the UK - final report. For: Department for Environment, Food and Rural Affairs.
- Larsen, A.W., Vrgoc, M., Christensen, T.H., Lieberknecht, P., 2009. Diesel consumption in waste collection and transport and its environmental significance. Waste Manag. Res. 27, 652–659. doi:10.1177/0734242X08097636
- Laurent, A., Clavreul, J., Bernstad, A., Bakas, I., Niero, M., Gentil, E., Christensen, T.H., Hauschild, M.Z., 2014. Review of LCA studies of solid waste management systems - Part II: Methodological guidance for a better practice. Waste Manag. 34, 589–606. doi:10.1016/j.wasman.2013.12.004
- Laurent, A., Hauschild, M.Z., Golsteijn, L., Simas, M., And, J.F., Wood, R., 2013. Deliverable 5.2: Normalisation factors for environmental, economic and socio-economic indicators. PROJECT: Development and application of a standardized methodology for the PROspective SUsustainability assessment of TEchnologies. Copenhagen, Denmark.
- M-E-L Research, 2008. The State of Composting and Biological Waste Treatment in the UK in the UK 2006 / 07. Association for Organics Recycling and WRAP, Wellingborough,.
- Merrild, H., Damgaard, A., Christensen, T.H., 2008. Life cycle assessment of waste paper management: The importance of technology data and system boundaries in assessing recycling and incineration. Resour. Conserv. Recycl. 52, 1391–1398. doi:10.1016/j.resconrec.2008.08.004
- Miasto Stołeczne Warszawa - The city of Warsaw, n.d. Ulotka "Jak segregować odpady" - "How to segregate the waste" (in Polish) [WWW Document]. URL http://czysta.um.warszawa.pl/documents/10181/0/naklejki_4.pdf (accessed 6.14.15).
- Miljøministeriet, 2013. Miljø- og samfundsøkonomisk vurdering af muligheder for øget genanvendelse af papir, pap, plast, metal og organisk affald fra dagrenovation [in Danish], Miljøprojekt nr. 1458. Copenhagen. doi:978-87-92903-80-8
- Miljøministeriet, M., 2014. Affaldsstatistik 2012.
- Ministry of Environment, 2010. The National Waste Management Plan 2014. Warsaw.
- Minoglou, M., Komilis, D., 2013. Optimizing the treatment and disposal of municipal solid wastes using mathematical programming—A case study in a Greek region. Resour. Conserv. Recycl. 80, 46–57. doi:10.1016/j.resconrec.2013.08.004
- Møller, J., Christensen, T.H., Jansen, J.L.C., 2011. Anaerobic Digestion: Mass Balances and Products, in: Solid Waste Technology & Management. Blackwell Publishing Ltd., pp. 618–627. doi:10.1002/9780470666883.ch39
- Møller, J., Jensen, M.B., Kromann, M., Lund Neidel, T., Bjørn Jakobsen, J., 2013. Miljø- og samfundsøkonomisk vurdering af muligheder for øget genanvendelse af papir, pap, plast, metal og organisk affald fra dagrenovation. Miljøprojekt nr. 1458. doi:978-87-92903-80-8
- NATURA srl, 2012. Analisi Merceologica dei rifiuti urbani [in Italian]. S.A.P.NA. Sistema Ambiente Provincia di Napoli S.p.A.
- Nemecek, T., Kägi, T., 2007. Life Cycle Inventories of Agricultural Production Systems. Data v2.0 (2007), Ecoinvent

report No. 15. Zürich and Dübendorf.

- Office for National Statistics, 2014. Main comparisons: Population and Migration [WWW Document]. URL <http://www.ons.gov.uk/ons/guide-method/compendiums/compendium-of-uk-statistics/population-and-migration/index.html> (accessed 7.5.15).
- Olesen, O.U., Damgaard, A., 2014. Landfilling in EASETECH [available under request from DTU]. DTU, department of Environmental Engineering, Copenhagen.
- Petersen, C., Domela, I., 2003. Sæmmensætning af dagrenovation og ordninger for hjemmekompostering. Miljøprojekt nr. 868 2003. Miljøstyrelsen, Miljøministeriet. København.
- Pressley, P.N., Levis, J.W., Damgaard, A., Barlaz, M. a, Decarolis, J.F., 2015. Analysis of material recovery facilities for use in life-cycle assessment. *Waste Manag.* 35, 307–317. doi:10.1016/j.wasman.2014.09.012
- RECOUP, 2014. *Plastics Packaging: Collection, Sorting and Reprocessing (CSR)*. Peterborough,.
- Reimann, D.O. (CEWEP), 2012. CEWEP Energy Report III (Status 2007-2010)- Results of Specific Data for Energy, R1 Plant Efficiency Factor and NCV of 314 European Waste-to-Energy (EtE) Plants.
- Resourcefutures, 2013. Defra EV0801 - National compositional estimates for local authority collected waste and recycling in England, 2010/11.
- Rigamonti, L., 2007. PhD Thesis - Valutazione dei percorsi di recupero di materiali e di energia in sistemi integrati di gestione dei rifiuti urbani [in Italian]. Polytecnic of Milan.
- Rigamonti, L., Grosso, M., Giugliano, M., 2010. Life cycle assessment of sub-units composing a MSW management system. *J. Clean. Prod.* 18, 1652–1662. doi:10.1016/j.jclepro.2010.06.029
- Rigamonti, L., Grosso, M., Giugliano, M., 2009. Life cycle assessment for optimising the level of separated collection in integrated MSW management systems. *Waste Manag.* 29, 934–944. doi:10.1016/j.wasman.2008.06.005
- Rigamonti, L., Grosso, M., Møller, J., Martinez Sanchez, V., Magnani, S., Christensen, T.H., 2014. Environmental evaluation of plastic waste management scenarios. *Resour. Conserv. Recycl.* 85, 42–53. doi:10.1016/j.resconrec.2013.12.012
- Rigamonti, L., Grosso, M., Sunseri, M.C., 2009. Influence of assumptions about selection and recycling efficiencies on the LCA of integrated waste management systems. *Int. J. Life Cycle Assess.* 14, 411–419. doi:10.1007/s11367-009-0095-3
- SHC Sabrowski-Hertrich-Consult GmbH, 2010. Zweckverband für Abfallwirtschaft Südwestthüringen (ZAST), Zella-Mehlis.
- Spielmann, M., Bauer, C., Dones, R., Tuchschnid, M., 2007. Transport Services. Data v2.0 (2007), Ecoinvent report No. 14. Villigen and Uster.
- Statistisches Bundesamt Wiesbaden, 2014. Umwelt - Abfallentsorgung 2012.
- Stella, M., 2013. Analisi merceologiche sui rifiuti urbani smaltiti in discarica : alcune riflessioni sulla composizione dei rifiuti urbani del Bacino 1 - secondo rapporto, in Italian. Consorzio Intercomunale Conero Ambiente, Ancona, Italy.
- Szpadt, R., Mac´ków, I., Sebastian, M., 2005. Efektywnos´c´ gospodarki odpadami opakowaniowymi zawartymi w odpadach komunalnych (Efficiency of packing waste management contained by municipal waste). *Mat. VI Mie´dz. Forum Gospodarki Odpadami, Poznan´ -Lichen´ Stary, Poland.*
- Tampere Regional Solid Waste Management Ltd., I/S Amager Ressourcecenter, Aalborg University, 2014. Review of plastic waste in municipal waste stream. LIFE10 ENV/DK/098 - with the contribution of the LIFE financial instrument of the European Union.
- The World Bank, 2014. Average precipitation in depth (mm per year) [WWW Document]. URL <http://data.worldbank.org/indicator/AG.LND.PRCP.MM> (accessed 7.13.15).
- The World Bank, 2011. Little Data Book on Climate Change: Supplemental Data.
- Theodoseli, M., Karagiannidis, A. (Aristotle U.T., 2004. Integration of Solid waste management Tools into specific settings of European and Asian Communities - activity 2: Literature review on waste generation and composition in Greece.
- Weidema, B.P., Bauer, C., Hischier, R., Mutel, C., Nemecek, T., Reinhard, J., Vadenbo, C.O., Wernet, G., 2015. The ecoinvent database: Overview and methodology, Data quality guideline for the ecoinvent database version 3.2 [WWW Document]. URL www.ecoinvent.org (accessed 2.21.16).
- Weidema, B.P., Wesnæs, M.S., 1996. Data quality management for life cycle inventories-an example of using data quality indicators. *J. Clean. Prod.* 4, 167–174. doi:10.1016/S0959-6526(96)00043-1
- Werner, F., Althaus, H., Künniger, T., Jungbluth, N., 2007. Life Cycle Inventories of Wood as Fuel and Construction Material. Data v2.0 (2007), ecoinvent report No.9. Dübendorf.

Witzenhausen-Institut für Abfall Umwelt und Energie GmbH, 2012. Orientierende Restmüllanalyse Abfallzweckverband Südniedersachsen (in German).

WRAP, 2015. Developing End Markets For PET Pots , Tubs and Trays.

WRAP, 2014a. Household kerbside collections [WWW Document]. URL <http://laportal.wrap.org.uk/Statistics.aspx> (accessed 7.5.15).

WRAP, 2014b. LA waste and recycling scheme search 2013/14 - Scheme data [WWW Document]. URL <http://laportal.wrap.org.uk/ORIS.aspx> (accessed 7.6.15).

WRAP, 2013. A survey of the UK organics recycling industry in 2012.