

## Microband Sensor for As(III) Analysis: Reduced Matrix Interference

Richard Dudeney<sup>1</sup>, Jeffrey D. Newman<sup>1</sup>, Frank Davis<sup>2</sup>, Steven J. Setford<sup>3</sup>, Ibtisam E. Tothill<sup>1,\*</sup>.

<sup>1</sup>*Cranfield University, Cranfield, Bedfordshire, MK43 0AL, England, UK.*

<sup>2</sup>*Department of Engineering and Applied Design, University of Chichester, Bognor Regis, West Sussex PO21 1HR, UK.*

<sup>3</sup>*LifeScan Scotland Ltd., Inverness, IV2 3ED, UK*

\*Corresponding Author. [i.tothill@cranfield.ac.uk](mailto:i.tothill@cranfield.ac.uk)

## **ABSTRACT**

A portable sensor based on a microband design for arsenic detection in drinking water is presented. The work was focused to minimize interference encountered with a standard screen-printed electrodes featuring three electrodes with onboard gold working electrode, carbon counter and silver–silver chloride pseudo-reference electrodes as composite coatings on plastic surface. The interference effect was identified as chloride ions interacting with the silver surface of the reference electrode and formation of soluble silver chloride complexes such as  $\text{AgCl}_4^{3-}$ . By modification of the reference electrodes with Nafion membrane (5% in alcohols), the interference was entirely eliminated. However, membrane coverage and uniformity can impact the electrodes reproducibility and performance. Hence, the design of the sensor was considered further and a microband format was produced lending favorable diffusive to capacitive current characteristics. Using the microband electrodes allowed As(III) detection with limit of detection of 0.8 ppb (in 4 M HCl electrolyte), inherently avoiding the problems of electrode fouling and maximizing analyte signal in river water samples. This is below the World Health Organization limit of  $10 \mu\text{g L}^{-1}$  (ppb). The electrolyte system was chosen so as to avoid problems from other common metal ions, most notably Cu(II). The presented electrode system is cost effective and offers a viable alternative to the colorimetric test kits presently employed for arsenic analysis in drinking water.

**KEYWORDS.** Microband electrode, gold electrodes, absorptive stripping voltammetry, arsenic.

## 1 Introduction

Arsenic (As) is a naturally occurring element and is found in metal ore deposits and can contaminate drinking water, therefore, requiring monitoring and regulating to ensure public health safety. Exposure to arsenic through drinking water sources can cause skin lesions, increased risk of cancer and damage to the circulatory system. As a global public health problem, the number of people reported to be affected is around 100 million. People at risk are particularly in Bangladesh [1], with previous reports listing other countries as Vietnam [2], Chile [3], Argentina [4] and India. Arsenic exposure has been predicted in regions of Indonesia and Myanmar where minimal testing has been conducted [5]. Four oxidation states (-3, +3, 0, and +5) of arsenic can exist in nature with  $\text{As}^{3+}$  being more toxic than  $\text{As}^{5+}$  [6]. The limit for allowable arsenic in drinking water is  $10 \mu\text{g L}^{-1}$  (ppb) recommended universally by the World Health Organization (WHO) [7]. Much of the work on water toxicity determination [8] and remediation of arsenic has been reviewed previously [9].

Due to high spatial variations in arsenic levels [10] safe and hazardous water supplies are often found interspersed. There is less data for temporal variation though it is thought to be low from studies in Bangladesh [11] and Nevada, US [12]. Besides direct exposure through drinking water, problems also occur by accumulation in rice [13] or it can be taken in by cows, contaminating the dung which is subsequently used as a fuel releasing airborne arsenic particulates [14]. Laboratory based methods for arsenic determination are both time consuming and expensive, but can detect arsenic at very low concentration. These include atomic absorption spectroscopy (AAS) [15-16], atomic fluorescence spectrometry (AFS) [17], inductively coupled plasma mass spectrometry or emission spectrometry (ICP-MS or ICP-AES) [18-19] and X-ray fluorescence (XRF) [20]. At present *in situ* methods include colorimetric and electrochemical methods, although colorimetric measurements dominate [21-22]. The foremost *in situ* techniques presently utilised are based upon the colorimetric test of Gutzheit whereby arsenic in the samples is reduced to arsine which is reacted with a mercuric bromide strip [23]. To quantify sufficiently low levels (sub 10 ppb) a spectrometer is needed to assess the colour change and to effect complete reduction, reaction times from 10 min up to 30 min are needed.

Also a number of problems have been encountered with these tests including unreliability at lower levels, difficulty in utilization by non skilled operators as well as user exposure to arsine [24]. However, recent refinements appear to have mitigated most of these issues [25]. A range of other colorimetric techniques utilizing organic reagents and dyes have been developed and these include reagents as silver diethyldithiocarbamate [26], molybdenum blue [27], methylene blue [28] and rhodamine-B [29].

The electrochemistry of arsenic has been the subject of various reviews [30-32]. Gold or mercury electrodes are most commonly used to investigate the electrochemical behavior of arsenic [30, 33], however, the toxicity of mercury itself discourages use of this material in the field. Gold electrodes were investigated and found to be preferable to platinum and silver for metals detection. A list of the various gold electrodes used has been previously published [32]. As an alternative to metal electrodes, pencil lead electrodes [34] have been used to determine As(III) in river and lake water using ASV in the range 5-100  $\mu\text{g L}^{-1}$  and achieving a detection limit of 1.6  $\mu\text{g L}^{-1}$ . Acidic conditions are normally required for effective reduction of arsenite and arsenate [30]. Hydrochloric acid between 0.1 and 7 M is the most common electrolyte used [31]. Determination of As(III) in 1 M HCl has been shown to give an excellent electrochemical peak [35] but suffers from interference if Cu(II) is also present in the sample.

The use of screen-printed techniques for the large scale manufacture of reproducible sensors and application in metal sensing has been widely demonstrated [36-38]. For example electrochemically deposited poly(L-lactide) stabilised 10 nm gold particles on carbon screen-printed electrodes [39] were used to determine arsenite down to 0.1 ppb, in a 1 M HCl medium. Prussian blue-modified carbon screen-printed electrodes [40] were used as the mediator for the oxidation of As(III) to As(V) by using a flow injection system with a limit of detection of about 1.5 ppb arsenic. By using carbon electrodes modified with micron-sized gold particles and carefully selecting the electrolyte (0.1 M  $\text{HNO}_3$ ), arsenic levels can be evaluated with a detection limit in the low ppb range [41]. Nanostructured materials have been introduced to enhance the performance of electrodes. Gold nanoparticle modified glassy carbon electrodes were used to determine As(III)

between 0.25-15 ppb [42] and other workers deposited citrate stabilized Au nanoparticles onto carbon to determine As(III) from 1-15 ppb with a detection limit of 0.025 ppb [43]. A system based on gold nanoparticles deposited by electrolytic methods onto a glassy carbon electrode [44] was used to determine As(III) by ASV with an LOD of 0.1 ppb or by As(III)-As(V) oxidation with an LOD of 0.3 ppb. Au nanoparticle multilayers on gold electrodes were used to detect As(III)-As(V) oxidation with a limit of detection of 4.36 ppb [45]. Carbon nanostructures have been also used as example carbon nanotubes can be dispersed into carbon paste electrodes and used to determine As(III) in brandy [46]. Whereas graphene can be used as a composite film with Au nanoparticles to detect arsenic in real water samples with a LOD of 0.2 ppb [47]. However, most of these methods are either not portable, not easy to use, expensive or suffer from matrix interference.

Work using gold screen-printed electrodes for arsenic determination has been reported [48-49]. However, composite materials such as found in these systems are of concern when stability of materials in the desired electrolyte conditions becomes compromised, especially if the electrolytes are corrosive, e.g. because of extremes of pH [50]. The use of screen-printed gold electrodes for determination of As(III) below the WHO limit has been described [51]. A 6 M LiCl electrolyte was used, however no work on metal interference was reported. Two current commercial protocols for determining arsenic have been reported [32], one being ArsenicGuard™ which is an automated electrochemical arsenic analyzer with a 4 ppb detection limit, and the other being the ArsenicCheck field test™ which is a chemical test based on reducing arsenic to arsine gas and reacting it with a mercuric bromide impregnated test strip. However, these methods have sensitivity or reproducibility issues as well as cost implications or use toxic chemicals are used which are not environmentally friendly.

A number of protocols have been developed for the construction of micro electrodes (which respond much faster and are non-stir dependent) using screen-printed substrates [52-55, 11]. One method is to make microband sensors which are essentially ultra-thin electrode strips, the thickness of typical screen-printed electrodes is 5 - 30  $\mu\text{m}$ , which is

small enough to allow convergent diffusion. The working electrode is sandwiched between two insulating layers with just the ink edge exposed. Since screen- printers cannot print with accuracy below 100  $\mu\text{m}$ , to provide the appropriate surface, the sandwiched layer is cut so as just to expose the edge. Screen-printed microband electrodes were made by using a scalpel to cut through a sandwich of conductive and insulating layers [55]. By using high-impact polystyrene for the insulation ink and substrate, the electrodes were found to be more reproducible when cut. Two further possible methods for preparation of the microband sensors have been described, one method involved using a drill to create a hole through a sandwich of inks [56] whereas the other utilises ultrasonic cutting to provide clean surfaces [57]. From the above review it has been shown that arsenic is a worldwide problem which needs solving. Numerous methods have been developed to detect Arsenic in drinking water samples, but most still suffer from either lack of sensitivity and reproducibility or prone to interference. Hence there is still a demand to develop better methods for arsenic detection and analysis. In the present work, we describe a method developed to produce microband electrodes which were then utilized for the determination of As(III) in water samples. Microband electrodes were obtained by cutting commercial screen-printed electrodes which were then used to determine arsenic using adsorptive stripping voltammetry. Initial results showed interference from silver leached from the reference electrodes so polymer coating were used to mitigate this. This was in order to produce sensitive and reproducible handheld sensors for arsenic detection with the aim of minimizing interference during the analysis.

## **2 Experimental**

### **2.1 Reagents and apparatus**

All reagents, unless otherwise stated were obtained from Sigma Aldrich (Poole, UK) including the As(III) standard solutions and were of analytical grade. Nafion was supplied as a 5% solution in alcohols, no further dilution was made. HPLC grade water was used for aqueous samples. Solutions were contained within disposable polypropylene sample tubes during interrogation or storage. Glassware was stored and washed in a 5 % nitric acid bath and rinsed before use with HPLC water. River water was hand collected

from the River Ouse (Bedford, UK) in a 100 ml bottle and spiked with As(III) from a concentrated solution.

## 2.2 Screen-printed electrodes

The DuPont UK (Electronic Materials Ltd, Bristol, UK) electrodes were printed (by Dupont) on a base layer of 125  $\mu\text{m}$  PET using carbon (product 7102), followed by silver/silver chloride (product BQ164), gold (product BQ331) and UV cured encapsulation ink (product 5036). The thicknesses of these layers, as reported by DuPont were 6, 25, 17 and 6  $\mu\text{m}$  respectively. Layers were cured by air drying at 130  $^{\circ}\text{C}$ . Initial experiments were performed with the DuPont electrodes intact. For some experiments the silver reference electrode was cut as shown (Figure 1A) and alternate substitute reference electrodes were added separately. A roller cutter (Avery, Precision Cutter 460 N) with approx. 5 cm diameter blade was used to cut the electrodes along the dotted line in (A), to produce a microband electrode as shown schematically in Figure 1B. An Olympus BX40 microscope (Olympus UK Ltd. Watford, UK) was used to obtain images of the electrode edges. Dimensions of the resultant gold microband electrode are 1.5 mm x 17  $\mu\text{m}$  giving a surface area of 0.026  $\text{mm}^2$ .

For the substitute reference electrodes used in subsequent experiments, inks used were Electrodag Carbon 423 SS and Electrodag Ag/AgCl 6038 SS (Acheson Colloids, Reading, UK). The base plastic was 250  $\mu\text{m}$  PET sheeting (Cadillac Plastics, Ltd, Swindon, UK). The electrodes were printed in house on a DEK 248 semi automatic printer (DEK, Weymouth, UK) using custom DEK 325 steel meshes. The tracks were 1.5 by 50 mm, with an over layer of silver ink 1.5 by 10 mm at one end. Additional substitute reference electrodes included screen-printed gold (cut from other DuPont electrodes), screen-printed carbon, as well as 1.6 mm diameter gold and carbon disk electrodes (BAS, West Lafayette, USA). Nafion 117 (product 70160, Sigma Aldrich) layers were prepared by pipetting 10  $\mu\text{L}$  of 5 % solution in alcohol on the printed silver reference electrodes and allowing to air dry.

## 2.3 Electrochemical measurements

An Autolab PGstat20 (Metrohem UK Ltd) was used with GPES v4.9 software. Anodic stripping voltammetry parameters were a deposition potential of -0.3 V for 180 s followed by 100 mv/s linear voltammetry from -0.3 V to 0.5 V. Cyclic voltammetric experiments scan rate were 50 mV/s and the scan range was -0.2 to 0.5 V. The electrolyte used for these experiments was 4 M HCl (care – corrosive).

For other electrochemical experiments standard gold (1.6 mm diameter) and glassy carbon (3.0 mm diameter) disk electrodes were used, obtained from Bioanalytical Systems, Inc., (BAS, West Lafayette, USA). The electrodes come housed in a 6 mm diameter cylindrical housing 7.5 cm long of poly(chlorotrifluoroethylene) (CTFE); a metal pin extends through the length of the housing providing electrical connection and protrudes 0.75 cm from the far end of the housing. Reference electrodes used were supplied by Bioanalytical systems, Inc.

X-ray photoelectron spectroscopy (XPS) was performed using a VG Scientific ESCA Lab 200D Surface Analysis Equipment for AES and XPS.

### **3 Results and Discussion**

#### **3.1 Electrochemistry of the screen-printed electrodes**

Initial studies were undertaken to determine the presence of any electrochemical behaviour at unmodified screen-printed electrodes in electrolyte solution suitable for arsenic analysis. A standard electrochemical cell was used first with a beaker (25 ml) of 4 M HCl. The experiment was repeated several times (with polishing of the gold disk electrode between each run). Figure 2, shows a standard gold disk electrode (with carbon disk counter and standard Ag/AgCl electrode) cycled from -0.2 V - + 0.5 V in 4 M HCl (A) as well as a DuPont electrode scanned (continuously) in 4 M HCl (B). The electrode here is in standard planar format i.e. not microband. With the standard cell there is no visible interference, apart from a small redox peak close to 0.4 V which decreases with scanning. By contrast a number of anomalous peaks are evident when using the DuPont



electrodes which are not present in the CV of the disk electrode. In excess of 40 electrodes were tested in this study. In general there are three redox peaks that occur when the electrodes are cycled in halide electrolyte, however no peaks were visible in non-halide electrolytes. The first redox peak is a broad peak between about 0 and - 0.1 V and grows over time with scanning. The height of this peak can vary between a few uA after 40 scans but can sometimes be as high as 40 uA. This is thought to be due to silver metal being oxidized to silver chloride and grows as more silver is deposited on the electrode.

A second redox peak is visible between 0.2 and 0.3 V and grows over time but does not get bigger than a few uA, this is thought to be due to silver under deposition [58]. A third narrow 'spike' peak occurs between 0.05 and -0.1 V and does not grow over time. Plausibly this could be due to a Frumkin effect due to charge-charge interactions of crystals of Ag/AgCl [59].

Since the DuPont electrodes showed these unexpected peaks in 4 M HCl, further studies were undertaken, with screen-printed electrodes being subjected to cyclic voltammetry in a number of electrolytes (0.5 to 4 M concentration range) including, hydrochloric acid, sodium chloride, potassium bromide, potassium iodide, sulfuric acid, sodium sulfate, sodium perchlorate, perchloric acid, nitric acid and sodium nitrate. The pattern or interference in the voltammograms was found to be dependent on halide anions, and relatively independent of acidity. Severity of interference increased with concentration and anion type such that  $I^- \gg Br^- \gg Cl^-$  (data not shown). An obvious possible origin of the peaks could be leaching of some constituents of the reference electrode into the electrolyte and contamination of the working electrode. According to the literature silver is soluble in excess halide electrolytes such that at high concentrations (halide > 1 M) the solubility increases from Cl<sup>-</sup>, Br<sup>-</sup>, to I<sup>-</sup> [60]. Simple silver chloride (AgCl) is highly insoluble, however at high concentration of chloride, soluble complexes such as AgCl<sub>4</sub><sup>3-</sup> are formed, allowing transport of silver to the working electrode [61]. This was confirmed by XPS spectroscopy. Figure 3, shows XPS spectra for an unused Dupont electrode and one cycled in 4M KBr for 40 cycles. In the used electrode, there are clear

silver peaks at 367 (Ag3d<sub>5/2</sub>) and 373 eV (Ag3d<sub>3/2</sub>) confirming that some silver species (silver halide complexes) are contaminating the gold working electrode and interfering with the arsenic analysis. These peaks are consistent with those previously reported for species such as silver chloride (367.7, 373.7 eV) considering the peak resolution is 1 eV [62].

As the screen-printed Ag/AgCl reference electrodes could not be used without contamination occurring when 4 M HCl was used, several alternate electrodes were tried as the reference including gold disks, gold screen- printed and carbon screen- printed electrodes. However, none gave potentials stable enough under the harsh nature of the electrolyte for arsenic analysis. A suitable substitute reference electrode was obtained using a silver/silver chloride electrode coated with a Nafion layer (5% solution in alcohols, 10 µl). For the purposes of development of this system, 4M KBr was used as electrolyte instead of HCl because the interferences were much greater, making the system much clearer to work with. Two different silver ink formulations were used to print the electrodes, Electrodag 6038 Ag/AgCl and DuPont BQ164. With the Nafion film, the interference is almost entirely (< 5 %) eliminated when the Electrodag electrode was used but only a partial reduction in interference was possible with DuPont BQ164 Ag/AgCl. By visual inspection the Nafion formed a coherent layer over the Electrodag silver but a more uneven layer over the BQ164 ink. Thus for the purposes of the following experiments, the Electrodag with a layer of Nafion was used as a reference electrode and was hooked to the potentiostat separately. In the 4 M KBr electrolyte, the Nafion layer gave an approximate 100 mV negative offset compared with a Nafion free electrode. Using the Nernst Equation this equates to an effective 0.08 M Br<sup>-</sup> concentration at the electrode. The substitute reference electrode also eliminated interference in the 4 M HCl electrolyte. This has shown that by using Nafion membrane on the reference electrode interference from the sensor itself can be minimized when using 4M HCl solutions.

### 3.2 Electrochemistry of As(III) at microband electrodes

To increase the sensor sensitivity electrodes were sliced with the roller cutter to provide an exposed gold edge. A microscope image of one example is shown in Figure 4A, the gold edge in the image is on the lower side placed on the top of carbon ink. The microband behavior was confirmed by cyclic voltammetry using potassium ferrocyanide (5 mM, 0.1 M sodium chloride) as a standard redox couple. In Figure 4B, 5 scans are shown and these display the typical sigmoidal shape of a microelectrode. Over a number of electrodes there was good repeatability; the variation in the maximum limiting current of 8 electrodes was  $\pm 10\%$ .

Using anodic stripping voltammetry with microband sensor in 4 M HCl, a series of concentrations from 0-20 ppb were examined (Figure 5A). There was some main interference therefore the results are presented with smoothing and baseline subtraction. A typical "raw" arsenic peak (20 ppb) is shown as is an electrolyte only scan (Figure 5B). The base line and peak height line are shown by way of example. A number of As(III) concentrations were examined to produce the calibration curves shown for As(III) in the range 0 to 20 ppb (Figure 5C). The plot shows As(III) can be detected in a linear range between 0-12 ppb with a sensitivity of 0.81 nA/ppb and an R<sup>2</sup> value of 0.97. Above 12 ppb the slope of measured current vs [As(III)] falls off and the calibration plot becomes curved. Limit of detection (3x standard deviation of the 0 ppb value/sensitivity) is 0.8 ppb. In early work we did attempt differential pulse voltammetry but initial experiments showed no advantage over linear sweep voltammetry.

Subsequently river water obtained from the River Ouse was spiked with As(III). Figure 6, shows the calibration profile for these "real" environmental samples. As can be seen As(III) can be measured in the range 0-20 ppb, both in pure water based electrolytes and those based on river water although there is some loss of sensitivity in the environmental sample. However, the river water samples as provided were about 2 weeks old, measurement of pure water based As(III) samples aged to the same extent showed a similar loss in signal, for on the spot field testing this would not be an issue.

### 3.3 Effect of Interferents

The anodic stripping procedure was applied in the presence of a number of interfering metal ions Cd, Cu, Pb, Fe, Cr, Zn and Bi (at levels of 100 ppb) with and without 10 ppb As(III). Cu, as already discussed is the most problematic ion likely to occur. However only Bi was found to overlap the As peak (Figure 7), but Bi is not likely to occur at this level in drinking water. None of the other potentially interfering metals gave peaks which overlapped the As(III) and therefore, interference in a mixed sample would not be a problem.

Table 1, shows the performance of a number of electrochemical sensing protocols for the detection of arsenic and compares them with our work. As can be seen, other procedures for determination of arsenic do display wider ranges and lower detection limits in some cases than our work. However in the field most testing is simply to determine whether or not water is safe to drink. Therefore, a sensor that gives measureable responses between 1-10 ppb is suitable for this work and whereas many of the other procedures utilize complex electrode materials which they have had to make from scratch, our protocol uses a simple commercial screen-printed electrode modified by cutting with a roller cutter and treating with a commercial polymer solution, meaning it will probably be much less expensive and more suitable for mass production than many of the procedures listed in Table 1.

#### **4 Conclusions**

Despite promising early results with As(III) determination on simple screen-printed electrodes, a persistent number of background interfering peak hindered As (III) analysis. Having eliminated most obvious problems with care taken in preparation of solutions and general cleanliness, efforts were directed at studying the interference directly. A pattern emerged where chloride solutions consistently led to interference, bromide and iodide had the same type of behavior but the interference was much more for a given concentration than chloride. XPS was used to investigate the elemental composition of the electrodes before use and after electrochemical cycling and the appearance of silver

on the gold electrode was very clear from the XPS spectrum. This may not be a problem in a short < 3 min test unless there is convection that could carry the complexes from the reference to the working electrode, a phenomenon that would be difficult to control in practice. As alternatives to the printed silver electrodes, carbon printed electrodes or carbon disk electrodes were investigated but failed to provide stable potentials. Nafion protected printed silver was utilised because often a layer of this material prevents anion migration whilst allowing cation migration. Additionally the Nafion layer should inhibit the silver halide complexes which would be expected to be negatively charged. A potential issue would be that Nafion could lead to a double layer effect reducing the halide concentration at the reference electrode surface, however there appears to be only minimal shifts in measured potentials, indicating that this is not an issue.

Within this work we also looked at the sensor design and how to modify it to improve its performance. A roller cutter was found to be successful and repeatable in constructing microband electrodes as borne out by experiments with ferrocyanide redox couple, showing typically sigmoidal voltammograms. Anodic stripping voltammetry, utilising the microband electrodes, shows and consolidates previous work in so far that As(III) can be determined below the WHO target of 10 ppb with disposable electrodes in drinking water.

However, there are a number of issues that need to be addressed before this can be incorporated into a useful format to be utilised in the field. An issue to confront is to attempt to measure the reduction of As(V) to see if there is a convenient way to include this into a self-contained test. Another challenge to this approach in the determination of arsenic in drinking water is the use of a hazardous concentrated acid electrolyte. The justification at this stage is that this test is to be compared with the colorimetric tests that at present involve toxic compounds such as arsine. The deciding factors on the utilisation of this test depends on the practicality of the test and whether the disposability of the screen-printed electrodes increases the convenience to the user enough to make uptake of this type of test worthwhile.

## Acknowledgements

The authors wish to express their appreciation to the DuPont UK (Electronic Materials Ltd, Bristol, UK) for supplying the screen-printed electrodes.

## REFERENCES

- 1 S.V. Flanagan, R.B. Johnston and Y. Zheng. Bulletin of the World Health Organization, 2012, 90,839-846. M.
- 2 Berg, M, H. C. Tran, T.C. Nguyen, H. V. Pham, R. Schertenleib and W. Giger. Environ. Sci. Tech., 2001, 35, 2621-2626.
- 3 A.H. Smith, M. Goycolea, P. Haque, and M. L. Biggs, Amer. J. Epidemiology, 1998, 147, 660-669.
- 4 C. Hopenhayn-Rich, M. L. Biggs, A. Fuchs, R. Bergoglio, E. E. Tello, H. Nicolli and A. H. Smith. Epidemiology, 1996, 7, 117-124.
- 5 L.M.B Winkel, M. Amini, S. J. Hug and C. A. Johnson. Nature Geoscience, 2008, 1, 536-542.
- 6 K. Shrivastava, R. Shankar, K. Dewangan, K., Sensors and Actuators B: Chemical, 2015, 220, 1376–1383.
- 7 <http://www.who.int/mediacentre/factsheets/fs372/en/> Accessed Jun 2017.
- 8 I.E. Tothill, Water & Sewage Journal, 2006, 4, 23-24.
- 9 V.K. Sharma, M. Sohn, Environ. Int., 2009, 35, 743-759.
- 10 P.L. Smedley, and D. G. Kinniburgh, Appl. Geochem., 2002, 17, 517-568.
- 11 Z. Cheng, A. van Geen, A.A. Seddique and K. M. Ahmed, Environ. Sci. Tech., 2006, 40, 1718-1720.
- 12 J.G. Thundiyil, Y. Yuan, A. H. Smith and C. Steinmaus, Environ. Res., 2007, 104, 367-373.
- 13 M.A. Rahman, H. Hasegawa, M. M. Rahman, M. N. Islam, M. A. M. Miah and A. Tasmin, Water Air Soil Pollut, 2007, 185, 53-61.
- 14 A. Pal, B. Nayak, B. Das, M. A. Hossain, S. Ahamed and D. Chakraborti. J. Environ. Monit., 2007, 9, 1067-1070.

- 15 E.M. Becker, M.B. Dessuy, W. Boschetti, M.G.R. Vale, S.L.C. Ferreira, B. Welz, *Spectrochim. Acta Part B*, 2012, 102–106.
- 16 H. Abdolmohammad-Zadeh, A. Jouyban, R. Amini, *Talanta*, 2013, 16, 604–610.
- 17 P. Cava-Montesinos, M.L. Cervera, A. Pastor, M. de la Guardia, *Talanta*, 2003, 60, 787–799.
- 18 J. Entwisle, R. Hearn, *Spectrochim. Acta Part B* 61 (2006) 438–443.
- 19 J.F.R. Paula, R.E.S. Froes-Silva, V.S.T. Ciminelli, *Microchem. J.*, 2012, 104, 12–16.
- 20 H. Barros, L.M.M. Parra, L. Bennun, E.D. *Spectrochim. Acta Part B* 65, 2010, 489–492.
- 21 US EPA Method 7063, [www.epa.gov/sites/production/files/2015-12/documents/7063.pdf](http://www.epa.gov/sites/production/files/2015-12/documents/7063.pdf), published 1996.
- 22 S. Hu, J. Lu, C. Jing, *J. Environ. Sci.*, 2012, 24, 1341–1346.
- 23 R.K. Dhara, Y. Zheng, J. Rubenstone, A. van Geen, *Analytica Chimica Acta*, 2004, 526, 203–209.
- 24 T. Kaufman, P. White, A. Dindal, Z. Willenberg and K. Riggs, EPA: Environmental Technology Verification Report: Industrial Test Systems, Inc. QuickTM II Test Kit, [https://archive.epa.gov/nrmrl/archive-etv/web/pdf/01\\_vr\\_quickll.pdf](https://archive.epa.gov/nrmrl/archive-etv/web/pdf/01_vr_quickll.pdf). Accessed June 2017.
- 25 C. M. George, Y. Zheng, J. H. Graziano, S. Bin Rasul, Z. Hossain, J. L. Mey, and A. van Geen, *Environ Sci Technol.* 2012; 46, 11213-11219.
- 26 Y. Wakui, T. M. Suzuki. *Anal Sci.* 2014, 30, 683-686.
- 27 S. Tsang, F. Phu, M. M. Baum, G. A. Poskrebyshev, *Talanta*, 2007, 71, 1560-1568.
- 28 S. Kundu, S. K. Ghosh, M. Mandal, T. Pal, A. Pal, *Talanta*, 2002, 58, 935-942.
- 29 P. Chakraborty, P. V. R. Babu<sup>1</sup> and V. V. Sarma, *Int. J. Environ. Anal. Chem.*, 2012, 92, 133-147.
- 30 A. M. A. L-S. Cavicchioli, and I. G. R. Gutz. 2004. *Electroanalysis*, 2004, 16, 697-711.
- 31 E. Munoz, E. and S. Palmero, *Talanta*, 2005, 65, 613-620.
- 32 J.H.T Luong, E. Lam, K.B. Male. *Anal. Methods*, 2014, 6, 6157-6169.
- 33 Y. He, Y. Zheng, and D. C. Locke. *Microchem. J.*, 2007, 85, 265-269.

- 34 K. Arai and K. Shimada, *Bunseki Kagaku*, 2012, 61, 411–418.
- 35 X. Dai, O.Nekrassova, M. E. Hyde and R. G. Compton, *Anal. Chem.*, 2004, 76, 5924-5929.
- 36 K. C. Honeychurch and J. P. Hart, *Trends Anal. Chem.*, 2003, 22, 456-469.
- 37 R.O. Kadara and I.E. Tothill, *Anal. Chim. Acta.*, 2008, 623, 76-81.
- 38 M Noh, M.F. M & Tothill, *I E. Sains Malaysia*, 2011, 40, 1153–1163.
- 39 Y.S. Song, G. Muthuraman, Y. Z. Chen, C. C. Lin and J. M. Zen. *Electroanalysis*, 2006, 18, 1763-1770.
- 40 J.M. Zen, P. Y. Chen and A. S. Kumar, *Anal. Chem.*, 2003, 75 6017-6022.
- 41 A.O. Simm, C. E. Banks, S. J. Wilkins, N. G. Karousos, J. Davis and R. G. Compton. *Anal. Bioanal. Chem.*, 2005, 381, 979-985.
- 42 E. Majid, S. Hrapovic, Y. Liu, K. B. Male and J. H. T. Luong, *Anal. Chem.*, 2006, 78, 762–769.
- 43 Y. Lan, H. Luo, X. Ren, Y. Wang and L. Wang, *Anal. Lett.* , 2012, 45, 1184–1196.
- 44 T. Gu, L. Bu, Z. Huang, Y. Liu, Z. Tang, Y. Liu, S. Huang, Q. Xie, S. Yao, X. Tu, X. Luo and S. Luo, *Electrochem. Commun.*, 2013, 33, 43–46.
- 45 Thotiyl, M. M. O., H. Basit, J. A. S´anchez, C. Goyer, L. Coche-Guerente, P. Dumy, S. Sampath, P. Labb´e and J.-C. Moutet, *J. Colloid Interface Sci.*, 2012, 383, 130–139.
- 46 M.C. Teixeira, E. de F. L. Tavares, A. A. Saczk, L. L. Okumura, M. das Graças Cardoso, Z. M. Magriotis and M. F. de Oliveira. *Food Chem.*, 2014, 154, 38–43.
- 47 Y. Liu, Z. Huang, Q. Xie, L. Sun, T. Gu, Z. Li, L. Bu, S. Yao, X. Tu, Z. Luo and S. Luo. *Sens. Actuators, B.*, 2013, 188, 894– 901.
- 48 J. Cooper, PhD Thesis, 2004, Cranfield University, Bedfordshire, UK.
- 49 M. F. M. Noh, PhD Thesis, 2005, Cranfield University, Bedfordshire, UK.
- 50 T. Navratil, T., M. Kopanica, J. Krista, *Chemia Analityczna*, 2003, 48, 265-272.
- 51 S. Laschi, G. Bagni, I. Palchetti and M. Mascini. *Anal. Lett.*, 2007, 40, 3002-3013.
- 52 Collyer, S.D, F. Davis and S. P. J. Higson. 2010. Sonochemically Fabricated Microelectrode Arrays for Use as Sensing Platforms, *Sensors*, 10: 5090-5132.



- 53 J.L. Chang, and J.M. Zen, *Electroanalysis*, 2006 a, 18, 941-946.
- 54 J.L. Chang, and J.M. Zen, *Electrochem. Comm.*, 2006 b, 8, 571-576.
- 55 L. Authier, C. Grossiord, P. Brossier and B. Limoges, *Anal. Chem.*, 2001, 73, 4450-4456.
- 56 F. J. Rawson, W. M. Purcell, J. Xu, D. C. Cowell, P. R. Fielden and J. P. Hart., *Electrochim. Acta*, 2007, 52, 7248-7253.
- 57 M. Hyland, K. Lorimer, P. J. Dobson and H. F. Askew. 2005. Patent WO/2005/121762, assigned to Oxford Biosensors Ltd, Oxford, UK, filed and published 2005.
- 58 G. Herzog and D. W. M. Arrigan, *Trends Anal. Chem.*, 2005, 208, 208-217.
- 59 G. Hills and F. Silva, *J. Electroanal. Chem.* 1982, 137, 387-392.
- 60 J. Kratochvil and B. Tezak, *Recl. Trav. Chim. Pay B.*, 1956, 75, 774-780
- 61 C. Sella and .D. Bauer, *Hydrometallurgy*, 1990, 23, 353-364.
- 62 C. A. Strydom and J. F. van Staden, *J. Electroanal. Chem.*, 1990, 277, 165-177.

## List of Figures.

Figure 1. Schematic of the screen-printed electrodes. Reference electrode removal (A); microband electrodes production (B).

Figure 2. Cyclic voltammograms of a gold disc electrode (A); a Dupont screen-printed electrode (B) in 4 M HCl.

Figure 3. XPS spectra of used and unused Dupont screen-printed electrodes.

Figure 4. (A) a microband electrode cut with a roller saw (B) CV of the electrodes in 5 mM potassium ferrocyanide/0.1 M sodium chloride.

Figure 5. (A) Measurement of As(III) peak height using linear stripping voltammetry for a number of concentrations, peaks have been smoothed and baseline subtracted; (B) peak for 20 ppb As(III) shown as raw data, noise is thought to be mains interference. (C) Calibration curve for As(III) between 0 and 20 ppb based on smoothed peak height with baseline subtraction. Deposition at - 0.3 V for 180 s then a linear strip at 100 mV/s.

Figure 6. Calibration curve for As(III) additions to river water. Calibration curve for As(III) between 0 and 20 ppb based on peak height. Deposition at - 0.3 V for 180 s then a linear strip at 100 mV/s.

Figure 7. ASV with 4 M HCl with 100 ppb of Bi(III) with and without 10 ppb As(III). Deposition 180 s at -0.3 V and stripping at 100 mV/s.

Table 1. Comparison of sensors for arsenic analysis.

Figure 1.

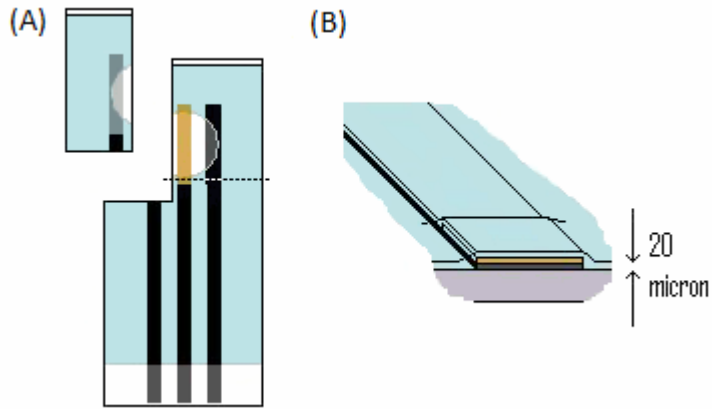

Figure 2.

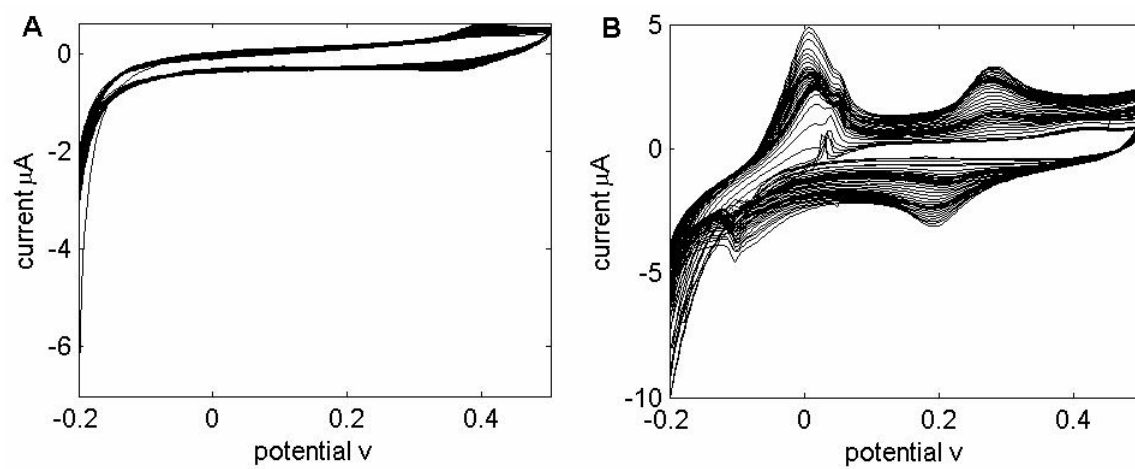

Figure 3.

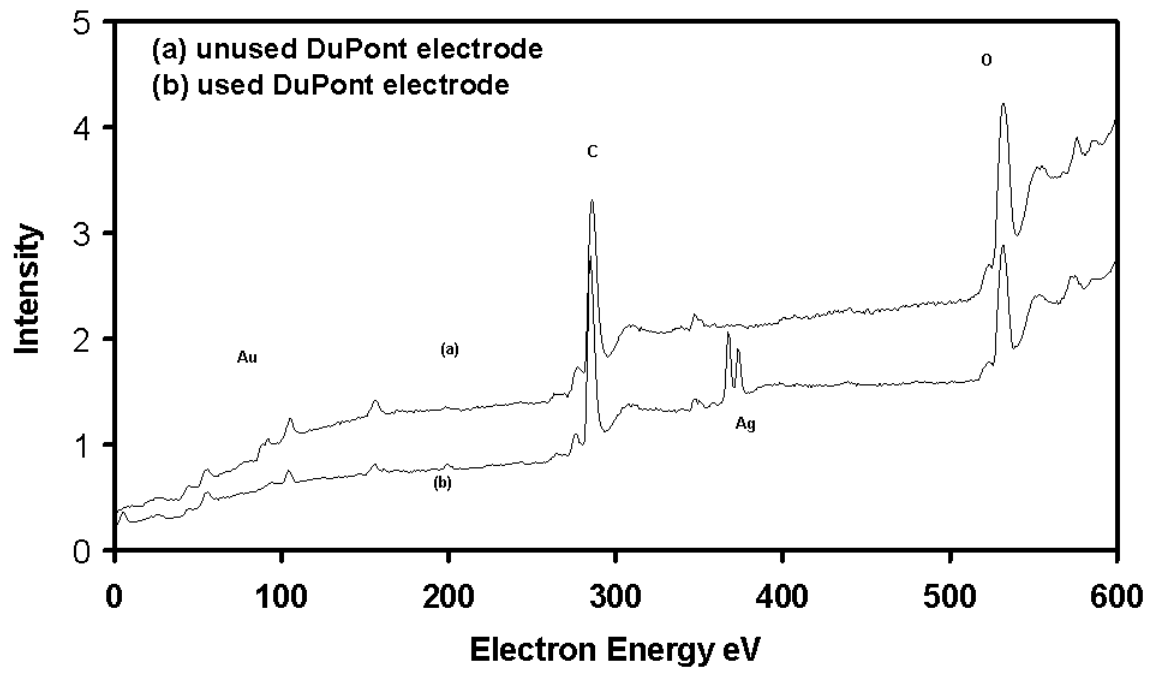

Figure 4.

A.



B.

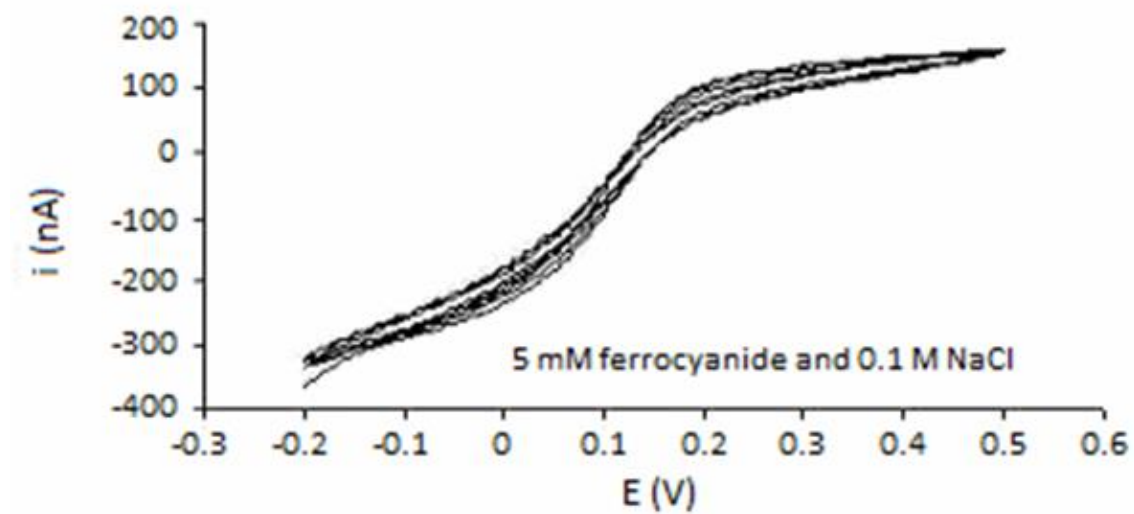

Figure 5.

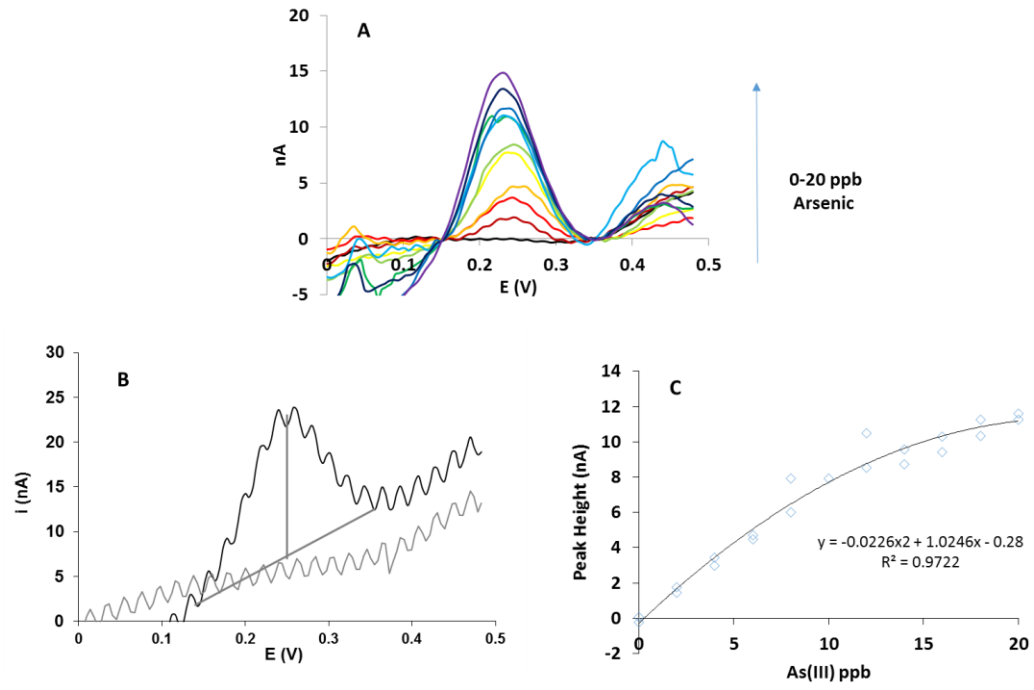

Figure 6.

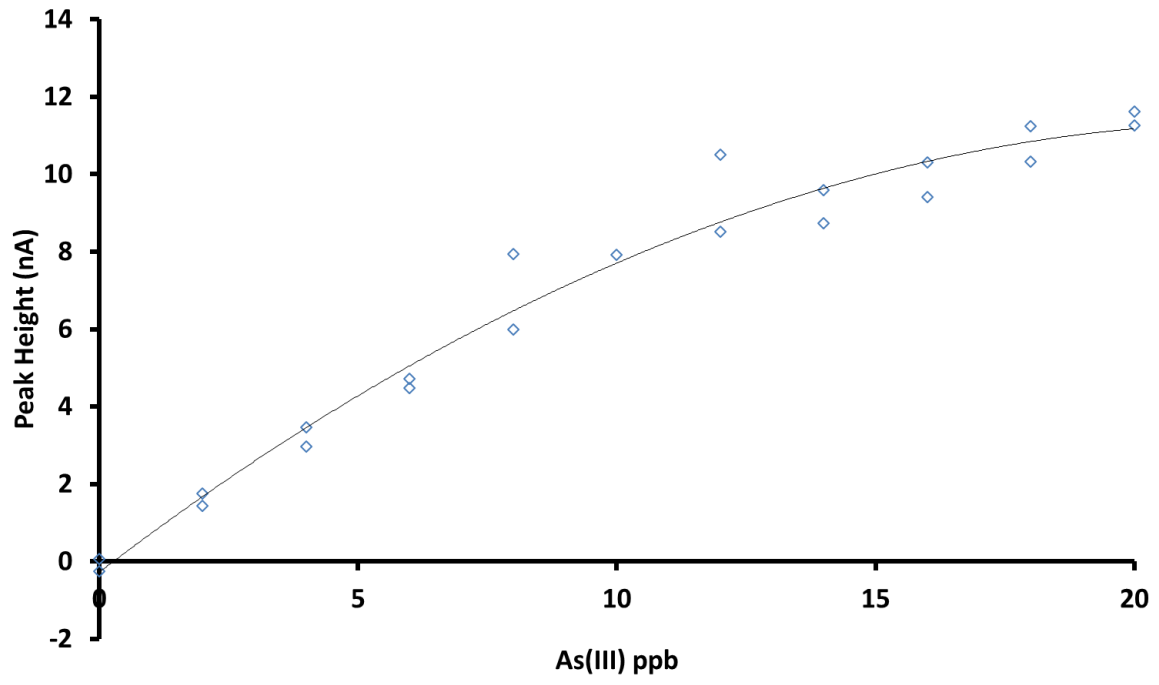



Figure 7.

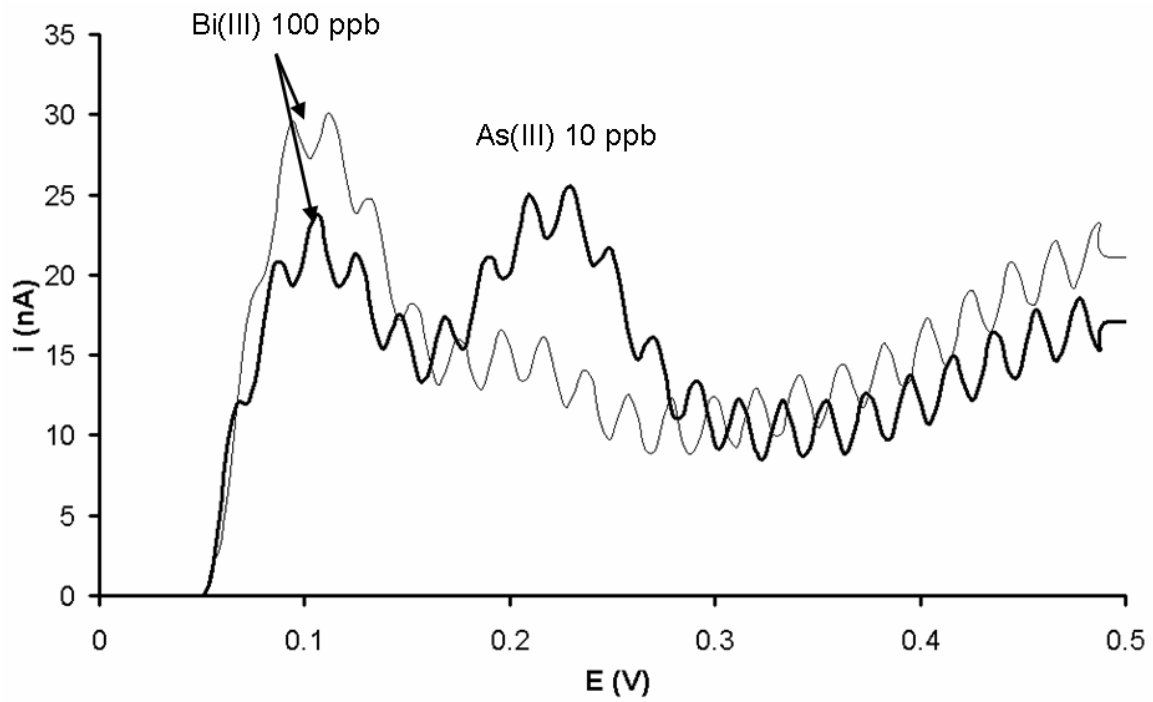

Table 1

<b>Method</b>	<b>Electrode Materials</b>	<b>Linear Range</b>	<b>Limit of Detection (LOD)</b>	<b>References</b>
ASV	Pencil lead	5-100 ppb	1.6 ppb	[34]
ASV	Au nanoparticle modified GCE		0.00096 ppb	[35]
DPASV	Au nanoparticle modified SPE	0-4 ppm	0.09 ppb	[39]
SWV	Prussian blue modified SCE	50 nM-300 $\mu$ M	25 nM	[40]
ASV	Au/carbon paste		5 nM	[41]
SWV	Au nanoparticle modified SPE	0-15 ppb	0.25 ppb	[42]
SWASV	Au nanoparticle modified GCE	1-15 ppb	0.025 ppb	[43]
ASV	Au nanoparticle modified GCE	0.02-3 $\mu$ M	0.9 nM	[44]
As(III) to As(V) oxidn	Polyelectrolyte Au nanoparticle		4.36 ppb	[45]
ASV	Graphene/Au Modified GCE	0.01 to 5 $\mu$ M	2.7 nM	[47]
ASV	Au/graphite in resin		0.32 ppb	[50]
SWASV	Gold SPE		2.5 ppb	[51]
ASV	Gold microband electrode	0-12 ppb	0.8 ppb	This work

ASV; anodic stripping voltammetry. DPASV; differential pulsed anodic stripping voltammetry, SWASV; square wave anodic stripping voltammetry, SWV; square wave voltammetry.

Table of Content graphic

