

California State University, San Bernardino

CSUSB ScholarWorks

Theses Digitization Project

John M. Pfau Library

1995

Evaluation of an echo-mobility program for young blind people

Charles Daniel Kish

Follow this and additional works at: <https://scholarworks.lib.csusb.edu/etd-project>



Part of the [Psychology Commons](#)

Recommended Citation

Kish, Charles Daniel, "Evaluation of an echo-mobility program for young blind people" (1995). *Theses Digitization Project*. 1036.

<https://scholarworks.lib.csusb.edu/etd-project/1036>

This Thesis is brought to you for free and open access by the John M. Pfau Library at CSUSB ScholarWorks. It has been accepted for inclusion in Theses Digitization Project by an authorized administrator of CSUSB ScholarWorks. For more information, please contact scholarworks@csusb.edu.

EVALUATION OF AN ECHO-MOBILITY PROGRAM
FOR YOUNG BLIND PEOPLE

A Thesis
Presented to the
Faculty of
California State University,
San Bernadino

In Partial Fulfillment
of the Requirements for the Degree
Master of Arts
in
Psychology: Life Span Developmental

by
Charles Daniel Kish
September 1995

EVALUATION OF AN ECHO-MOBILITY PROGRAM
FOR YOUNG BLIND PEOPLE

A Thesis
Presented to the
Faculty of
California State University,
San Bernadino

by
Charles Daniel Kish

September 1995

Approved by:

Frederick A. Newton, Chair, Psychology

9/7/95
Date

David H. Warren

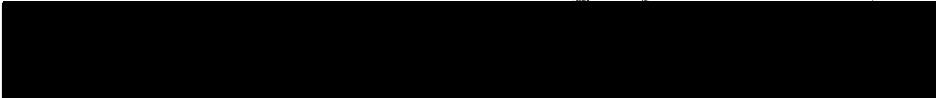
Stuart R. Ellins

Copyright 1995 by Daniel Kish

Abstract

A pilot program to train echo-mobility was conducted involving 23 blind participants aged 4.5 to 15 years. Approximately 6 hours of training were administered over a 14 week period. The purpose was to test and refine techniques for teaching and improving echo-mobility in different ages of blind children. The hypothesis that improvement in echo-mobility would result from such training was tested. A pre-treatment/post-treatment measure was administered to 12 of the participants to determine the extent of echo-mobility improvement on two tasks - straightness of travel, and target location. Statistical analyses revealed no improvement in target location, but marginal improvement was demonstrated in straightness of travel. Further analyses confirm that these improvements were attributable to echo-mobility skill. The marginal results are attributed primarily to an assessment instrument that was not sufficiently sensitive to detect improvement, and was not robust to random error. Qualitative observations indicate a

marked improvement for most of the participants in the recognition and application of a wide variety of echo skills. Qualitative data clarify several avenues toward improving the research design, and yield a variety of specific techniques and approaches toward increasing the effectiveness of echo-mobility training. The implications of echo-mobility training are discussed in detail.

Acknowledgments

First, I acknowledge Derik DeVecchio for his tireless and unswerving assistance in the design and construction of the apparatus, the coding and analysis of data, and the formatting of the manuscript.

I acknowledge Dr. Frederick Newton for his experienced direction, his insights and assistance in a variety of technical and administrative matters, and his patience and trust through virtually every step of this project.

I thank Dr. David Warren for his invaluable insights into the unique issues surrounding the study of blind children.

I acknowledge Dr. Stuart Ellins for his meticulous editorial assistance, and his ability to apply his knowledge of the perception of bats to that of men.

I thank the O & M instructors (J. C. Christopherson, Joan Washington, Kathleen Marcum, and Mike Thuis) who gave me so much of their time and

attention, and their willingness to be flexible, helpful, and supportive.

I thank Sean Branon for his contribution of diagrams, and Sean Branon and Carolyn McCollum for their assistance in data coding.

I thank my parents (all 3), my brother and sister in-law, and John Baker for their assistance with the driving, and the arduous mechanics of assembling and disassembling the apparatus.

I thank the Redlands Lions Club and the Rancho Cocomunga Lions Club for their monetary contributions to the project.

I thank Edith Amrine, Ken Stuckey, Dr. Gunar Jansson, and the personnel at the Institute of Occupational Health in Helsinki for their assistance in locating obscure and well hidden materials.

I thank Dr. Lawrence Rosenblum, Duen Yen, the late Dr. Everet Hill, Dr. William De l'Aune, Dr. Mathew Riggs, Dr. Jack Loomis, Dr. Dianne Fazzi, Dr. David Guth, Dr. Samuel Genensky, Dr. William Wiener, and Dr. Sandy Rosen for their advice, enthusiasm, and encouragement.

I thank the following people for their role as judges: Carolyn, Marylon, Romona, Craig, and Carla. I also thank Dr. David Chavez for referring these people to me.

Last but most important, I thank my participants and their parents for their time and cooperation.

Table of Contents

Abstract	iii
Acknowledgments	v
List of Tables	xii
List of Figures	xiii
HISTORICAL OVERVIEW	5
Facial Vision	5
Facial Vision to Echo Perception	7
Lessons from Hind-Sight	14
WHAT IS ECHO PERCEPTION?	18
HOW ECHO PERCEPTION WORKS	23
Sound and Echo	24
The Echo Observer in the Acoustic Field	29
The Nature of Echo Information and Perception	31
Object Detection	32
Object Perception	50
Object Location	59
Integrating Echo Perception Variables	61
Interpreting Echo Information	65

Signal Parameters	66
The Ideal Signal	91
ACQUISITION OF ECHO PERCEPTION SKILL	101
Developing A Training Program	108
STATEMENT OF THE PROBLEM	114
METHOD	116
Participants	116
Participant Groupings	116
Background Characteristics	117
Apparatus	123
Stimuli	123
Procedure	125
Standardization	125
Assessment	127
Training Program	130
Data Collection	147
RESULTS	150
Hypothesis Testing	150
Straightness of Travel	150
Target Location	164
Explorative Statistics	167
DISCUSSION	169

Issues in Assessment	169
General Observations	176
Alternative Procedures	179
Implications and Concluding Remarks	183
APPENDIX A	190
TRAINING PROGRAM FOR ECHO-MOBILITY	190
Lesson Plan	190
APPENDIX B	221
Materials	221
Artificial Stimulus Materials	221
Guiding and Measuring	222
Attachment Implements	223
Supporting Materials	223
Camouflage Materials	225
Teaching Aids	225
APPENDIX C	227
Assembling the Apparatus	227
Camouflage and Protection	227
Plexiglas Stands	227
The Assessment Track	233
Stimuli	234
APPENDIX D	238

Observations and Considerations of Echo	
Training Based on 150 Hours of	
Teaching	238
Starting Out	238
A Flexible Hierarchy of	
Echo-Mobility Development	242
Appropriate Echo Signals	248
Factors That Effect Echo-Mobility . .	250
What Helps or Hinders	
Echo-Mobility	253
Age Factors	254
Residual Vision	256
Special Notes	257
REFERENCES	265

List of Tables

Table 1. Count of Students With and Without Post-Assessment Scores for Different Causes of Blindness.	120
Table 2. RMS Deviation Scores for both Pre-Assessment and Post-Assessment.	154
Table 3. RMS Deviation Scores for 21 students in the Pre-Assessment Test for both Weak and Strong Echo Cue Conditions.	163
Table 4. Means and Ranges of Inter-rater Correlations for Large and Small Targets.	165
Table 5. Ratings by 5 Judges of Target Location for Students Finding the Large and Small Targets.	166

List of Figures

- Figure 1. Distribution of RMS scores for
students in the strong echo cue condition . . . 153
- Figure 2. Deviation from center of course in
strong echo cue condition for student 1. . . . 155
- Figure 3. Deviation from center of course in
strong echo cue condition for student 2. . . . 155
- Figure 4. Deviation from center of course in
strong echo cue condition for student 3. . . . 156
- Figure 5. Deviation from center of course in
strong echo cue condition for student 4. . . . 156
- Figure 6. Deviation from center of course in
strong echo cue condition for student 5. . . . 157
- Figure 7. Deviation from center of course in
strong echo cue condition for student 6. . . . 157
- Figure 8. Deviation from center of course in
strong echo cue condition for student 7. . . . 158
- Figure 9. Deviation from center of course in
strong echo cue condition for student 8. . . . 158

Figure 10. Deviation from center of course in strong echo cue condition for student 9. . . .	159
Figure 11. Deviation from center of course in strong echo cue condition for student 10. . . .	159
Figure 12. Deviation from center of course in strong echo cue condition for student 11. . . .	160
Figure 13. Deviation from center of course in strong echo cue condition for student 12. . . .	160
Figure 14. Distribution of Pre-Assessment RMS Deviation Scores for the Weak Echo Cue Condition.	161
Figure 15. Plot of the change in the RMS scores of 12 students as a function of lesson time spent with each student.	168
Figure 16. Expanded view of lower stand assembly.	228
Figure 17. Top view of assembled stand with panel.	230
Figure 18. Side view of assembled stand and panel.	231
Figure 19. Different target configuration that yielded different echo mobility tasks.	235

According to Emerson Foulke (1971), a prominent figure in the field of perceptual psychology who himself is blind, "The ability to travel safely, comfortably, gracefully, and independently ... is a factor of primary importance in the life of a blind individual" (p. 1).

Since the mid 18th century, the ability of some blind people to perceive objects from a distance has been of gradually mounting human interest, probably due to its apparent capacity to enhance those assets of nonvisual travel of which Emerson Foulke so eloquently wrote (Norris, Spaulding, & Brodie, 1957; Barth & Foulke, 1979; Warren and Kocon, 1974; Zemtsova, Kulagin, & Novikova, 1962). Over the centuries, anecdotes have abounded of some blind people processing remarkable awareness of their surroundings, and of their ability to move through them with ease and grace without guidance or the need to feel about (Lende, 1940). Examples of documented reports of such abilities can be found as far back as Diderot who wrote in 1749 of a blind friend so sensitive to his surroundings that he could

distinguish an open street from a cul-de-sac (discussed in Hayes, 1935; Griffin, 1958/1974/1986). Felts (1909), wrote of a totally blind acquaintance who went regularly about the crowded streets of New York with perfect ease and freedom without the use of a cane or any sort of guide. Hayes (1935) tells of a six year old blind boy able to ride his tricycle along the sidewalk without a blunder. More recently, a newspaper article was published describing a 13 year old blind boy who skates with phenomenal agility in congested public rinks (Nicolosi, 1994). At about the same time, a story was aired on national television about a totally blind man riding a bicycle at respectable speeds through the streets of an unfamiliar neighborhood, and an array of iron poles and pedestrians in a school yard unknown to him (Garrison, 1994).

Even a few experimental reports attest to remarkable abilities in a few of the blind. McCarty and Worchel (1954), for instance, studied an 11 year old, totally blind boy who could avoid obstacles placed in his path with almost perfect accuracy while

riding his bicycle at top speed. Personal contact with this participant (B. Taylor, April 26, 1995) revealed that he, like the man described by Felts in 1909, traveled freely about his town, school, and college campus without the use of a cane or guide until his mid 20's. In 1974 Magruder studied a blind man who could describe with great precision the distance, direction, dimensions, and general nature of novel objects as far as 13 feet away in unfamiliar environments. Personal contact with the participant (L. Scadden, personal communication, May 5, 1993) found that he too, blind from the age of 4, rode a bicycle on a regular basis as a boy.

Reports from among those who work with the blind as well as the blind themselves under-score the veracity and significance of documented phenomena. All of over a dozen mobility and special education instructors informally surveyed by this author have known of at least one student with remarkable skills of spatial awareness and mobility. In addition, several personal acquaintances reveal further tales of impressive ability to perceive surrounding by

nonvisual means. "... the better one becomes acquainted with blind people, or the more one reads about their abilities, the more obvious it is that some objects can be detected well in advance of actual contact" (Griffin, 1986, p. 299).

Even so, it has not been until about the past six decades that this sense in the blind of the presence and position of objects around them without tactual contact has come under careful empirical study. Such study may be of incalculable value to blind people everywhere by making available the knowledge needed to improve vastly nonvisual competence in spatial awareness and travel. A thorough understanding of the nature of this skill could have staggering implications for training and rehabilitation. This report examines thoroughly the empirical findings as well as modern theoretical perspectives concerning echo perception, and explores the logistics of designing and implementing an effective program to train and refine echo perception abilities in the blind.

HISTORICAL OVERVIEW

An excellent review and examination of the earliest investigations into the sense of objects by the blind is provided by Hayes (1935). A brief review is given here to provide a context for understanding more modern research of the issue.

Facial Vision

The first documented consideration of the sense of objects is found in an account by the French philosopher Diderot in 1749 about a blind friend who was reportedly able to judge "... the nearness of bodies by the action of the air against his face." [Diderot's observation is widely cited in the literature on human echo perception, but particular attention thereto is given by Griffin (1958/1974/1986) and Hayes (1935).] From that time to the early 20th century, two major sets of theories evolved regarding the nature of this sense.

One set constituted the tactile or skin sense theories which proposed, much as Diderot suggested in 1749 (reprinted 1951), that the blind were sometimes able to sense, through the skin of their face, some systematic change in subtle properties of nature that alerted them to the presence of objects in their vicinity. These explanations were derived in large part from the reports of many of the blind that they felt the presence of obstacles through the skin of their face. Though these remained the predominant theories until the early 1940's, little agreement was reached regarding the exact natural properties involved, or, specifically, how by what means were these properties perceived. These theories ranged from hyper-sensitivity to air currents and temperature, to perception of light or other electromagnetic waves through specialized nerves in the face, to a recognition of ether waves and other occult forces.

A second set of theories comprised the audition theories which implicated the mechanisms of the ear. These fell into two main classes - the pressure theory

which stated that the tympanic membrane was sensitive to subtle changes in air pressure caused by the presence of objects, and the auditory theories which asserted that the ear can perceive subtle variations in sound waves as they bounce off objects.

Throughout the late 19th and early 20th centuries, studies on the object sense in the blind were carried out with some rigor, and, in the face of evidence for all sides, the tactile theories held sway. Thus, by the turn of the century, the term "facial vision" came to be applied most commonly to this little understood phenomenon - implying that sensory mechanisms in the face provided some pseudo-visual perception of space. It was not until the 1940's that a series of unassailable studies of this ability in humans laid the controversy squarely to rest.

Facial Vision to Echo Perception

In the early 1940's Dallenbach and his associates at Cornell University investigated the specific

sensory processes involved in the nonvisual detection of obstacles (Cotzin, 1942). This investigation took the form of three sets of studies in which auditory, tactile, and tympanic stimuli were each systematically controlled.

In the first two sets of experiments (Supa, Cotzin, & Dallenbach, 1944; Worchel & Dallenbach, 1947), 2 blind, 10 deaf-blind, and 2 sighted participants, all blindfolded, walked under varying conditions toward an obstacle. This obstacle usually consisted of a maisonite screen 0.25 inches thick by 48 inches wide by 58 inches tall which was raised so that its upper edge was 82 inches above the floor. Both the position of the screen and the starting point of each participant were varied randomly throughout an 18 by 61 foot chamber. All participants were asked to indicate when they first perceived the obstacle (first perception), and to stop as close as possible to the obstacle without touching it (final appraisal). Ratios of these figures were then calculated for each participant in each trial so that performance in each condition could be measured. Reliability of

participant judgements was rigorously controlled by setting up the obstacle while participants were outside the chamber, and randomly introducing check trials in which no obstacle was present. Several sets of 25 trials constituted each condition in both studies.

In all experiments in which participants' hearing was left in tact, performance was consistently good for the blind and fair for the sighted. When participants walked with shoes on over a hardwood floor, the 2 blind participants were readily able to perceive the obstacle at distances as far as 24 feet. After about 9 practice trials, the sighted became able to perceive the obstacle up to about 6 feet. The blind and sighted were also able to edge to within half a foot of the obstacle on most occasions without touching it. When this exercise was repeated with footsteps muffled by stockinged feet on thick carpet, all performance indices dropped somewhat for all participants, but performance still remained relatively consistent. Performance was only slightly effected when participants' faces were loosely veiled

and hands covered by thick cloth that air currents could not penetrate. [In 1953 Kohler and his associates obtained similar results by anesthetizing the skin of first one, then both sides of participants' faces (reported in Kohler, 1964).] In an experiment that removed all stimuli other than hearing, participants were still able to estimate obstacle distance with fair accuracy. In this experiment the blind and sighted participants listened through headphones in a separate room to the experimenter's footsteps transmitted via microphone held by the experimenter as he walked with shoes on over the bare floor toward a stone wall. Under these conditions first perceptions and final appraisals of the experimenter's approach to the wall were not greatly impaired, and the patterns of occasions in which the participants allowed the experimenter to collide with the wall resembled participant collisions in other experiments where hearing was left in tact.

In those experiments in which the hearing of the participants was heavily occluded, however, the participants evidenced no ability to detect the

obstacle. They collided with the screen on every one of 100 trials. [Similar results were obtained in a later investigation by Ammons, Worchel, and Dallenbach, (1953) with 20 deafened participants out-of-doors.] Moreover, when the deaf-blind participants, all of whom had inner ear disruption leaving the tympanic membranes in tact, ran through a similar series of experiments, not one could perceive the obstacle in any one of hundred's of trials. [This finding was also replicated later by Worchel and Berry (1952) with 10 deaf-blindfolded participants who failed to perceive obstacles out of doors given 210 trials.]

Thus, the investigators established a clear relationship between the presence of perceptible sound and the ability to detect obstacles, and no such relationship involving tactile sensation. It was concluded that auditory perception is "necessary and sufficient" for the detection of obstacles, and that sound waves (such as those emanating from footsteps) reflected by the obstacle comprise the primary stimuli. However, the specific components of

reflected sound that make obstacle detection possible without vision still needed clarification.

In an additional series of experiments (Cotzin and Dallenbach, 1950), 2 sighted and 2 blind participants listened through headphones to a microphone-speaker assembly in a separate chamber. Participants could move this assembly by remote control toward a large maisonite screen similar to that in the previous studies, while signals of various types were emitted from the speaker. The participants were able to vary the rate of motion of the assembly, and give first perceptions and final appraisals as in the previous studies. Nine types of signals were emitted from the speaker - thermal noise (white noise) and eight pure tone frequencies. The thermal noise covered the audible spectrum from 100 Hz to 10 kHz, while the eight pure tones ranged by octave intervals from 125 Hz to 10 kHz. With white noise participants' performances were comparable to performances shown in the earlier studies in which participants themselves walked toward the obstacle. When the pure tones were used, however, participants listening through

headphones were unable to detect the obstacle with any but the 10 kHz tone. Even so, performance using this tone fell greatly short of performance with white noise. Though participants sensed the proximity of the screen reliably with the 10 kHz tone, they were unable to estimate distance reliably. Participants reported that, as the assembly approached the obstacle, they could judge its proximity by a change in the nature of the signal which seemed to constitute a rise in pitch. This change was most perceptible when using the white noise, less so with the 10 kHz tone, and not at all with the other tones. These reports were similar to those given by participants in an earlier experiment (Cotzin, Worchel, and Dallenbach, 1944) in which the sounds of the experimenter's footsteps were transmitted to the participants by microphone and headphones. In light of these reports, the experimenters concluded that the perception of obstacles without vision depends on a rise in the pitch of sounds as they are reflected or echoed from approaching surfaces, and that this rise in pitch is only perceptible with frequencies around

10 kHz and above. Since these three reports, terms that refer to the perception of echoes - "echo detection," "echolocation," "echo ranging" - have come into common use in reference to the nonvisual perception of obstacles by humans.

Lessons from Hind-Sight

Perhaps it should not be too difficult in some respects to understand why this controversy over the perception of objects by nonvisual means should have raged for so long. In truth, as indicated earlier, the blind themselves are notoriously mystified as to the nature of these perceptions (Supa, Cotzin, & Dallenbach, 1944; Juurmaa, 1969). Even some with extraordinary skill are unable to report how they accomplish this feat (Felts, 1909; Shephard & Howell, 1980). Indeed, many skilled at the perception of objects report this perception as a distinct sensation or pressure on the face (Juurmaa & Järvillehto, 1969; Juurmaa, 1970a; Ono, Fay, Tarbell; 1986; Schenkman,

1985b). Two explanations of this sensation have evolved.

The first implicates an increase of muscle potential tension in the face due to unconsciously learned anxious responses to the proximity of objects (Dolanski, 1931; Taylor, 1962). Echo perception is typically an unconscious process (Juurmaa & Järvillehto, 1969; Juurmaa, 1970a) learned primarily by random trial and error (Juurmaa, 1969; Worchel & Mauney, 1950). When objects are struck it is typically the head and face that receive the most memorable impact. An unconscious connection is thereby drawn between actual object perception through unconsciously processed echo information, and an involuntary response of muscle tension in the face. This perspective need not invalidate the subjective tactile experience often associated with obstacle perception. In fact, Juurmaa and Järvillehto (1969; Juurmaa, 1970a) use this experience to justify a distinction between phenomenal experience and functional stimulation. This distinction is best exemplified in studies which report tactual sensations

in participants exposed to the presentation of phantom obstacles created by sound synthesis techniques (Kohler, 1967).

A more recent empirical explanation involving a series of studies (Ono, Fay, Tarbell, 1986) indicates that the experience of tactile, facial sensations is connected with vision. Although these authors did not compare people blinded early in life to those blinded later on, they found that much higher percentages of sighted than blind people reported the experience of tactile sensations in the face when objects were near. In addition, the sighted participants reported experiencing a dim light upon closed eye lids as facial pressure. These authors suggest that those blind later in life may associate the presence of objects - once a consciously visual experience - with genuine sensations upon the face. Thus, the term "facial vision" may have, at least in small part, arisen from actual phenomena. It is of interest to note in relation to these considerations that a lengthy series of obstacle perception training studies reported by Ammons, Worchel, and Dallenbach (1953)

with 20 sighted-blindfolded participants failed to yield a single report of "facial vision" - i.e., experience of tactile sensation or pressure. All of the participants became aware of the auditory nature of the perception, though many also reported imaginal visual experiences such as "black curtains" and "dark shades" that seemed to coincide with close proximity to the obstacle.

At any rate, whatever the reasons for the protracted confusion of the past, Griffin (1958/1974/1986) points out a lesson to be learned: "In retrospect it seems clear that most of the better controlled experiments, as well as many of the most carefully collected introspective reports ... indicated a preponderant importance of hearing." (p. 303) He notes further that the most rigorous studies in the 1700's of an apparently similar ability in bats to detect and locate objects without the use of vision also found hearing to be of primary importance. Yet, these most salient examinations of this phenomenon in bats as well as in humans went unrecognized and unappreciated for almost 200 years, and the link

between the related phenomena in bats and men did not become thoroughly clarified until about the 1960's with the astute observations of Griffin (1958) and the insightful work of Kellogg (1962/1964).

Investigations into echo perception in animals as well as humans have since united to develop a greater understanding of this ability, and how it can be applied to effective mobility without vision.

WHAT IS ECHO PERCEPTION?

As indicated earlier, "echo perception" is an aspect of auditory perception which may be broadly defined as the ability to perceive echoes. On the surface, such an ability seems unremarkable and of little value - largely because echoes are not believed to convey much information. They are often thought to be a specialized phenomenon unique to specific circumstances such as firing a gun in the mountains, or calling out in caves and tunnels. But this is like saying that light reflects only from mirrors and highly polished surfaces.

In actuality, the visual system is enabled to perceive its surrounds by its ability to process the complex patterns of photons of visible light as they reflect from surfaces in those surroundings. If all we could see were sources of light and not reflected light, our eyes would give us very little awareness of the nature of our surroundings. By perceiving and interpreting patterns of reflected light, extremely rich and detailed information can be gathered about the layout and characteristics of surrounding space and objects therein.

Vision and audition are close cousins in that both can process reflected waves of energy. Vision processes photons (waves of light) as they travel from their source, bounce off surfaces throughout the environment, and enter the eyes. Similarly, the auditory system can process phonons (waves of sound) as they travel from their source, bounce off surfaces, and return to the ears. Both systems can extract a great deal of information about the environment by interpreting the complex patterns of reflected energy that they receive. As Gibson put it "There is a flow

of energy, the ambient array of radiant energy reflected from every face and facet of every surface and object in the environment" (Scwartz, 1984, p.27). Though Gibson was referring to light energy, in the case of sound, these waves of reflected energy are called echoes.

Echoes occur to varying degrees and forms under virtually all circumstances in all environments that support life as we know it. This information can be perceived and processed by the auditory system to enable a great many determinations about surrounding space and one's physical relationship to it.

The functional effectiveness of echo perception in animals who possess little or no vision is legendary and little questioned. Lee, van der Weel, Hitchcock, Matejowsky, and Pettigrew (1992) point out that certain species of bats can use echoes elicited by their own ultrasonic chirps to "move as gracefully as birds through the cluttered environment" (p. 563), and to negotiate obstacles as thin as 0.65 mm. These authors further indicate that some echolocating bats can develop a precise spatial memory of previously

explored environments to an accuracy within 2 centimeters. Griffin (1958/1974/1986) points out that the capture of insects as minute as 0.2 mm without the use of vision poses little difficulty for many species of bats. Numerous investigations such as these concerning nonvisual navigation and foraging by bats, nocturnal birds, and marine animals (Ayrapetyants & Konstantinov, 1974; Griffin, 1958/1974/1986) clearly demonstrate that echoes can provide detailed and consistent information about the surrounding environment that is pragmatically useful to auditory observers in the animal kingdom.

Studies along similar lines of blind humans do not demonstrate the ability to negotiate micro-thin wires or swoop down with expert precision on the tiniest of insects, but the results are nevertheless striking in the context of practical functioning demanded by human civilization. It has been shown, for example, that the blind can sense the presence of small objects from 2 to 3 meters away (Jones & Myers, 1954; Myers & Jones, 1958; Rice, Feinstein, & Schusterman, 1965), judge the distance of a single

object to within scarce inches at close range (Juurmaa & Järvillehto, 1969, Juurmaa, 1970b; Kellogg, 1962/1964), ascertain the lateral location of a single object to within a few degrees (Rice, 1969; 1970), judge size variations to mere fractions of an inch at close distances (Juurmaa & Järvillehto, 1969; Juurmaa, 1970b; Kellogg, 1962/1964; Rice & Feinstein, 1965), and determine distinct shapes of objects (Hausfeld, Power, Gorta, & Harris, 1982; Rice, 1967a, 1967b, 1967c) and textures of surfaces (Hausfeld, Power, Gorta, & Harris, 1982; Juurmaa & Järvillehto, 1969; Juurmaa, 1970b; Kellogg, 1962/1964). Mills (1961, 1963) demonstrated one participants' ability to detect a one meter by half a meter cardboard target as far away as 100 feet, and Rice (1969, 1970) found one blind man who could reliably detect the presence of a 1 inch disk 3 feet away. In order to understand fully the experimental findings and appreciate the implications of echo perception research, it is essential to have at least a basic grasp of how echo perception works.

HOW ECHO PERCEPTION WORKS

Approaches through physics and mathematics to the study of sound and environment, together with many behavioral studies of the use of echoes by animals and humans under varying conditions have led to an incomplete but nevertheless practical understanding of the processes behind echo perception and its utility. Eloquently simple and concise examinations of human echo perception are given by Rice (1967c) and Welch (1964). For more extended and detailed examinations of the processes involved, see Griffin (1958/1974/1986), and Rice (1967a). For more technical analyses see Schenkman (1985b) and Wilson (1967).

Three components must be present for the perception of echoes to take place - sound, a surface or surfaces to reflect sound, and an observer with auditory receptors to receive and cognitive processes to perceive and process the reflected sound (Rice, 1967a, 1967c). The quality at which these echoes are perceived depends upon characteristics of each of these three components, and the spatial relationship

among the components (Wilson, 1967). The complex process of echo perception arises from the interaction of all these factors. Each of these factors is briefly considered, and their interactions are discussed.

Sound and Echo

All environmental spaces that support human life are pervaded by a diverse array of sound. This diversity of sound can be simplified as varying according to five basic parameters - directionality, pitch, timbre, intensity, and envelope.

Directionality refers to the degree of focus of a sound as it emanates from a source. The focus may vary from unidirectional like the narrow field of a trumpet, to omnidirectional like the surrounding field of a drum or cymbal. The bell of the trumpet and other horns helps to focus its blast so that most of the acoustic energy travels in a beam-like effect. The term unidirectional refers to travel primarily in one direction. The drum has no such mechanism to

"beam" the sound, so its acoustic energy radiates about evenly in all directions or omnidirectionally.

Pitch simply refers to the frequency of the sound as on a musical scale, but the "notes" are called "frequencies" and are measured in Hz or kHz. The lowest frequency that the human ear can typically register is about 20 Hz, where the highest is usually around 20000 Hz or 20 kHz. In musical terms, this range is equivalent to about ten octaves.

Timbre refers to the spectral composition of the sound, or, in essence, chords or clusters of frequencies. These clusters of frequencies may comprise timbres ranging in complexity. Simple timbres involve relatively few frequencies such as in the human whistle or a tuning fork, while complex timbres involve many frequencies as in the human voice or an automobile engine. In addition they may be narrow band where all the frequencies occur within just a few octaves like an "s" sound, to broad band where the frequencies span many octaves like a jet airplane or radio static.

Intensity merely refers to how loud the sound is, and it is usually measured in decibels or dB.

The term envelope is a little more complex. It refers to three temporal factors - rise time or attack (the length of time for the sound to increase from zero to peak intensity), sustain time (the length of time that the sound remains at its average intensity), and decay (the length of time for the sound to decrease from average to zero intensity). A hand clap, for example, has a rapid rise and sustain time, and decays quickly. A gong rises much more slowly, sustains briefly, and takes a very long time to decay. For purposes of studying echo perception, these three values are often combined for a total temporal measure called duration.

Each of these five basic parameters is determined by the physical properties of the cause or source of the sound.

When a sound is produced, it travels in the form of waves of energy that radiate linearly from the origin of the sound. Hence, these waves assume parameters of shape and dimension that embody the

basic parameters of sound just described. For example, high pitched sounds are carried by short wave forms, and complex sounds may be carried by broad wave patterns with short and long dimensions. Sound waves are most cohesive and carry the most energy at or near their origin. As they travel away from their source, however, their energy wanes until they either lose all cohesion and diffuse completely, or, more likely, until they encounter surfaces in their path. The interaction between the original sound waves (sometimes called incident waves) and interposing surfaces results in the reflection of that energy. The parameters of the reflected energy are altered from the original according to the reflective characteristics of the environment in which the sound waves travel.

Reflected energy may occur in the form of discrete echoes of specific source sounds such as when a call is heard to reflect off the mountains or a distant building, or in the form of sustained echoes called reverberations such as the result of yelling in a gymnasium or stair well (W. Del l'Aune, personal

communication, May 6, 1993). Reverberations are formed from many echoes resulting from one or more sounds cascading about and around many surfaces or surface features. Reverberations from the ongoing array of ambient source noise set up standing reflections, called reverberant fields, that are more or less continuous. This effect is well known even to those who do not depend upon echoes by the "ocean in the seashell" phenomenon. When one places a seashell near one's ear, it is said that one can "hear the ocean", as though a piece ocean actually remains within the shell. In fact, this effect is produced by sounds in the environment which reverberate within the shell's chamber - causing a continuous "whoosh" of sound. A similar phenomenon is found in all containers with solid surfaces such as a glass jar, a stairwell, and to a lesser extent, hallways and interior rooms. The ambient source noise that elicits reverberant fields may be of very great or low intensity, and can be found just about anywhere there is a medium through which sound waves can travel (Wilson, 1967). Except when specifically referring to

discrete echoes, the term echo can be used to include all forms of reflected sound including reverberant fields (Schenkman, 1985b). The total array of original energy patterns and patterns of echoes comprise the "acoustic field"

The Echo Observer in the Acoustic Field

A well-tuned, auditory observer stands within a sea of information communicated by sound and echo. Acoustic fields pervade both urban settings where sounds of traffic, air conditioners, and milling crowds abound, and rural settings where the lighter sounds of birds, trees rustling, and footsteps upon the gravel path predominate. They pervade even spaces generally thought to be silent - arising from combinations of the subtlest sounds such as the gentle hum of electrical wiring, the all but diffused sounds from distant spaces, the brush of a person's clothing, the ebb and flow of breath, the merest trickle of saliva, even the soundless sounds of heart beating and blood pulsing. Myers and Jones (1958) found that 18

blind children could reliably detect a four by one foot wooden panel at a distance of four-and-a-half feet in a sound proof, anechoic chamber under environmental conditions believed completely silent. Five out of eight blind children from a separate group under identical environmental conditions were able to detect six foot cardboard strips as narrow as four inches at distances up to 8 feet.

According to Wilson (1967), the occasions are most rare that ambient noise levels approach absolute silence. The ocean depths of the seashell may be heard in even the most silent places. Such perceptions as those of Myers and Jones' participants (1958) are possible by the interpretation of the arrays of even the subtlest ambient noise which form delicate collages of discrete echoes and reverberations which fill spaces and connect all surfaces therein by a webwork of reflected energy. De l'Aune and his colleagues demonstrated this by analyzing stereo spectrograms of straight vs. t-intersecting segments of a corridor which was unoccupied and devoid of obvious sound (De l'Aune,

Gillespie, Carney, & Needham, 1974; also reported in De l'Aune, Scheel, Needham, & Kevorkian, 1974). These recordings were taken through a set of artificial ears. It was found that frequencies under 200 Hz were more intense in the t-intersection, and frequencies of 800, 1000-1300, and 1800 Hz were more intense in the straight segment - with differences being most pronounced in the ear facing the side of the corridor with the t-intersection. By these subtle changes, De l'Aune, Scheel, Needham, and Kevorkian, (1974) found that many blinded veterans could reliably distinguish between the straight segment and the t-intersection of this corridor.

The Nature of Echo Information and Perception

The characteristics of echoes are defined largely by the same parameters that define source sound, and, like source sound, each echo parameter is determined by the physical properties of the cause - i.e., the reflecting surface. It is, therefore, possible to determine the nature of reflecting surfaces and

objects by interpreting the parameters of the echoes they reflect. The variations in echo parameters can be interpreted meaningfully, because they correspond directly to environmental configurations.

Object Detection

Object detection - the ability to distinguish between the presence or absence of an object - is the most basic element of echo perception. It may also be the most important, since no other information such as distance, location, orientation, size, and composition of objects and surrounding surfaces can be gleaned unless the mere presence of the object is detected.

The ability to detect object presence or absence simply relies on the observer's ability to perceive and recognize the presence of the echo cast by the object. If an echo is present, then a reflecting surface must also be present. If there is no echo, then there is either no object present, or an object is present whose surfaces are only capable of casting echoes that are too weak to be heard. As such, this

simple ability to detect objects through echoes might be said to depend most - if not entirely - on the parameter of intensity, since the presence of an echo is defined by some measure of intensity.

Empirical investigations into simple, nonvisual object detection have been largely concerned with the effect of echo intensity on detection performance. The intensity of an echo depends upon the amount of sound energy reflected back to the ears of the observer. The factors involved in varying echo intensity primarily concern target parameters, the type of sound sources used to elicit echoes, and the spatial relationship between target, sound source, and observer's ears.

Target Parameters

The more reflective is a surface, the more energy is reflected, and the more intense the echo. Target geometry and composition are probably the key factors that contribute to its quality of reflectivity, and, therefore, to the strength of the returning echo.

Target geometry. Targets of different dimensions and curvatures effect echo strength or intensity by reflecting varying proportions of acoustic energy back to the observer. Rice and Feinstein (1965b) varied the ratio of target length to width, and curvature at a constant distance of 4 feet from four blind participants. Half the trials involved no target. The participants reported whether or not they detected the target when prompted. All targets were sixteen square inches, but the dimensions varied from 4 by 4, 8 by 2, and 16 inches by 1 inch. Object detection became poorer at this distance as the ratio of length to width increased. The thinner the target, the more difficult it was to detect, even though the surface area of the target remained the same.

Thinner targets tend to scatter or diffract more energy than they reflect. Thus, a smaller proportion of the echo returns to the observer. In an attempt to reduce the amount of lost energy and thereby increase that returned to the observer, the longer targets were curved to an arc matching a radius of four feet - the observer's head being the center. This created a kind

of partial dish to focus rather than scatter the energy. All participants were able to detect even the thinnest targets when more of the energy was reflected by their curvature.

Target composition. Targets of lesser density are not good reflectors. Soft surfaces, for example, tend to absorb much of the energy, and sparse surfaces such as chain link fences pass rather than reflect most of the energy in the same way that narrow surfaces do (Twersky, circa 1950). Juurmaa and Järvillehto (1969; Juurmaa, 1970b), for instance, spectrum analyzed the audible output of an ultrasonic echo receiver. [Such devices emit ultrasonic waves, receive the returning echoes, and electronically translate that ultrasonic echo into audible tones and timbres that correspond to the parameters of the echoes received.] The translated output of echoes from metal, pasteboard, and cloth were analyzed. The signal quality was distinct between all three materials - particularly between the harder surfaces

and cloth. One of the key distinctions involved intensity, where echoes from cloth were the least intense.

Similarly, targets of extreme smoothness such as glass or acrylic tend to reflect less energy back to the observer than do courser surfaces such as wood or pasteboard (Twersky, 1950; 1951a). Twersky indicates that glass surfaces such as store windows proved somewhat more difficult for sighted-blindfolded participants to localize (Twersky, 1951a). Sound waves tend to slide off highly polished surfaces - causing a larger quantity of energy to be scattered. Eighteen sighted-blindfolded and one blind participant studied by Hausfeld, Power, Gorta, and Harris (1982), for example, found it difficult to distinguish 20 centimeter diameter disks of Plexiglas and low pile carpet from each other, and from wood or cotton fabric, but wood and fabric were readily distinguished from each other. Dolanski (1930; 1931) similarly found that the distance and size at which disks of iron, glass, and cloth were detectable did not vary according to material among 42 blind participants.

Apparently smooth glass, plastic, and even iron may scatter about as much energy as cloth absorbs. It should also be considered that the targets used in these investigations were quite small, and may have been more difficult to discern than larger targets. Juurmaa and Järvillehto (1969; Juurmaa, 1970b) found that 7 blind participants were generally able to make clearer distinctions between metal, pasteboard, and cloth when the sizes exceeded 40 centimeters.

Kohler (1964) found very clear relationships between absorption properties of object surfaces and their detectability when ultrasmooth surfaces were not used. Distances at which cardboard, rubber, felt, or wading were first detectable diminished as absorption increased.

Source Sound

A more detailed discussion of the effect of source sound variables on echo perception is reserved for a later section. Suffice it to say for now that, in order for an echo to occur, there must be a sound

source to generate it. As seen earlier, very little energy is needed to generate some form of echo. However, it is not unreasonable to suppose that greater amounts of source sound would serve to generate echoes of greater amount or intensity. If echoes of greater intensity are more easily heard, then they should facilitate object detection.

Supa, Cotzin, and Dallenbach (1944) conducted a series of studies in which a 48 by 58 inch maisonite screen raised 2 feet off the floor was placed before 2 sighted-blindfolded and 2 blind participants. The screen was placed at distances varying randomly between 6 and 3y feet. In an unspecified number of trials for each series, the screen, without participant knowledge, was not placed in the path of travel. Participants walked down the path, and indicated when they first perceived the screen. Echo intensity was controlled here by varying the level of the sound of participants' footsteps as they walked. Two series of 50 trials each were run. In the first, participants walked over the hardwood floor with shoes on. In the second, they walked in stockinged feet

over a strip of very thick carpet. In neither condition was the obstacle falsely detected when it was absent from the path. When it was present under the condition of greater sound intensity, one of the blind participants was able to detect it reliably at a little more than 17 feet; the other could sense it about 4 feet away. The two sighted participants, both of whom had received previous training for this experiment, were able to perceive the screen at a little over three feet. When walking under the less echo intensive condition, the distance at which the screen was first detected diminished by about 53 to 68 percent among all of the participants, and all detections were less certain. This finding was replicated almost without exception in three additional experiments conducted under similar conditions.

Myers and Jones (1958) presented a wooden panel one foot wide by four feet tall to 18, seated, blind participants at a distance of about four feet. Echo intensity was controlled by removing all possible noise from the test environment, and varying the

amount of noise that participants could make. Experiments were conducted in a sound proof, anechoic chamber under two conditions - each involving a group of nine participants. In one, participants had to indicate whether the panel was present or absent without making a single sound or movement including breathing. In the other, participants could make whatever noises they wished before deciding. Though the results are not clear, they favor detection under the condition involving sound generation.

Spatial Relationship Between Target and Observer

Distance. As a general rule, echo intensity decreases as the distance that the echo travels increases. Kohler (1964), for example, found, through spectrum analysis, that the intensity of white noise and pure tones of upper frequencies decreased as a cardboard disk of 50 centimeters diameter was moved away from the sound source. An investigation by Jerome and Prochanski (1947; 1950) varied the distance

in one foot increments from three to nine feet between four blind participants and a maisonite panel three feet wide and six feet tall. No panel was present in half of the 60 trials. Results clearly show that the panel became more difficult for all participants to detect reliably as its echo strength was diminished by the increase in distance. Detection errors involved both falsely detecting the panel when it was not present, and failing to detect the panel when it was. Correct detections fell from between 73 and 100 percent at 3 feet, to between 34 and 80 percent at nine feet. Thus, the increase in distance from three to nine feet decreased echo intensity sufficiently to impair object detection for even the most proficient of the participants.

Distance and size. Several studies examine the effect of varying both target geometry, namely size, and distance on object detection. A thin target reflects less energy by scattering a large part of the energy away from the observer. A small target

delivers a similar effect by presenting a smaller surface area to the on-coming sound wave. Most of the wave, therefore, tends to pass around the target rather than being caught and returned by it.

Dolanski (1930; 1931) measured the effect of size on the maximum distance at which an object was detectable. Disks decreasing in diameter from 500 to 20 millimeters were moved toward 42 blind participants until the participants reported detection. Experiments were conducted in which the disks were moved frontally (directly toward the face), and laterally (directly toward each ear). The results of both conditions show a clear relationship between diameter of target and distance of detection - with larger disks being necessary for detection at further distances. The smallest disk that could be detected at close range was about 100 millimeters frontally, and about 40 millimeters at either side. [The relationship between horizontal target position and detectability is discussed later.] Although Dolanski failed to include blank trials regularly, the

relationship between size and distance of targets in echo perception has been widely reported.

Rice, Feinstein, and Schusterman (1965) used stimuli similar to that of Dolanski. Aluminum disks of varying sizes were presented at distances of 2 to 9 feet from 5 blind participants. The target was omitted in half of the trials at each distance, and participants were asked to indicate whether the target was present or not. A linear relationship similar to that in Dolanski's investigation was found between size and distance. As the distance increased, disks of greater size were required for detection to remain reliable.

Jones and Myers (1954) found comparable results using vary different stimuli. They tested the ability of over 30 blind participants to detect six foot cardboard strips ranging in width from 2 feet to 1 inch, and varying in distance from 3 to 6 feet. Blank trials were included in 25% of 40 trials for each participant. Though detection of the larger strips was only slightly impaired by increasing distance, the

smaller strips were generally much more difficult to detect as distance increased.

Finally, in a program designed to train three participants with progressive vision loss, Juurmaa, Suonio, and Moilanen (1968; Juurmaa, 1968b) found that it took longer for participants to learn to perceive a pasteboard panel 20 centimeters wide than one 40 centimeters wide, though a difference in height from 1 to 2 meters seemed not to effect detection performance.

Horizontal target position. Four studies have examined the effects of horizontal target position on echo detection ability. By horizontal position, it is meant that the targets in all studies were presented at the level of the ears. In a study by Kohler (1964) in which a 50 cm cardboard disk was presented in many locations around the heads of 20 participants, detection was most accurate when the disk was presented directly in front of the participants. Detection performance worsened gradually with movement to side positions, and diminished further with

movement behind the head. Rice (1969, 1970) also found with 8 blind participants and 3 sighted-blindfolded participants that detection reliability rolled off as the target was moved from the frontal position to side positions. In Schenkman (1983), the detection performance of 4 blind participants presented from the side with cardboard rectangles ranging from 1.03 x 0.73 to 0.365 x 0.515 m were compared to that of six blind participants presented with a 0.38 m aluminum disk from the front. None of the participants in the side presentation condition were able to detect any of the targets reliably, but detections were common with those participants presented with targets from the front - even as far away as four M.

A study by Dolanski (1930; 1931) contradicts the findings of Kohler (1964) and Schenkman (1983) concerning detection of laterally placed targets. In Dolanski's study, 42 blind participants were presented with disks made of different materials and varying in size from 20 to 500 mm diameter. These participants

were able to detect all of the targets at about 50 percent greater distances from the side than in front.

There are not enough data available to enable a clear understanding of the contradictory nature of these findings. Different sound sources used at different positions may have effected results. For example, the participants in the Schenkman (1983) study used cane taps as echo signals, while the echo signals used by Dolanski's participants (1930, 1931) were not specified. It may be that cane taps are not optimal for the detection of elevated targets. A sound emitting device was used in the Kohler (1964) study. Its nature is also unclear, however, though other facets of the study utilized the device at chest level. It may be that lateral position of objects facilitates echo perception over frontal position under certain conditions, but those conditions are not known.

Vertical target position. Studies are contradictory concerning the accuracy of echo

perception as a function of vertical position. The Kohler (1964) study presented in the previous section also charted detection accuracy for positions below and above the head, and found that detection accuracy fell off as the cardboard disk moved below or above the level of the ears. However, Schenkman (1983) found in 8 blind participants that detection was more accurate for objects placed at waist than at head level. Interestingly, the difference between object heights was greater for objects placed 4 m away than those placed 2 m distance.

Again, signal characteristics may be responsible for the apparent contradiction in these findings. It may be that cane taps, as were used in Schenkman (1983), optimize detection of objects at waist level. This possibility is examined in a later section.

Target obliquity. In previous sections it was made clear that target dimension greatly affects echo perception ability. Smaller or narrower surfaces scatter acoustical energy so that much of the

returning energy is lost. A study by Clarke, Pick, and Wilson (1975) investigated the degree to which target obliquity also affected echo perception. In 12 blinded and four blindfolded-sighted participants, the ability to detect flat surfaces of different sizes and distances tapered off sharply as the angle of rotation was increased with respect to the participants. For example, at a distance of one meter a board 90 cm wide became undetectable at an angle of approximately 20 degrees. Two elements seem to contribute to this affect. First, as objects become more oblique, their surfaces divert the acoustic energy away from the observer. Also, as targets grow more oblique, they may also grow thinner as the target is presented more edge-on. This results in a scattering of much of the acoustic energy so that, depending on the thickness of the target, little of it may be returned.

Affects of Sound Source Position

Two principal studies have examined the affect on echo perception of the position of the sound source

with respect to the listener. Kohler (1964) found that blind participants were able to detect obstacles with at least double the accuracy when they carried the signal source rather than relying on reflections cast by the irradiation of the environment with ambient noise. Thus, echoes are apparently most audible when the sound source is close to the body. Schenkman (1985a; 1985b) examined the affect of vertical sound source positioning on the echo perception of five blind participants. Detection of a 2 x 0.5 m surface at distances of 1, 3, and 5 M was tested with the noise generator located near the head, waist, and feet. It was found that detection was generally most accurate with the sound source located at the waist, and least accurate with location at the head.

Object Perception

The term "object perception" is generally used in the literature to refer to the assimilation of object

features through tactual exploration. Here, the term refers to assimilation through echo interpretation.

Distance Perception

According to Schenkman (1985b), features of both envelope and pitch parameters are the primary components of the perception of distance for humans using echoes.

Concerning the envelope parameter, there is an additional component in echoes called "time delay". This refers to the temporal interval between the onset of the source sound and the beginning or onset of the perceived echo. This delay increases directly with distance from the origin of the source sound. Inversely, as the distance decreases, so does the time delay between the sound and the echo. As the distance becomes very small (about 2 to 3 meters) the time delay decreases to a point at which the human ear can no longer tell the sound and its echo apart.

At this point, the ear comes to rely on the pitch parameter for distance judgements. As the distance

decreases between the surface and the observer and/or sound source, the pitch of the echo is perceived to rise with respect to the source pitch. This change in pitch is best demonstrated by Bassett and Eastmond (1964). By spectrographic analysis they showed that the spectral characteristics of white noise change systematically as a microphone is moved from the sound source toward a surface at which that source is aimed. This change results from cancelation of certain frequencies and augmentation of others in direct relation to the proximity of the surface to either the speaker (i.e., the origin of the source sound), or the microphone (i.e., the observer). These changes are explained by interference patterns between the reflected wave and the incident wave which is heard as a rise in pitch as the surface is approached. While participants throughout the literature have reported this rise in pitch to be a primary cue in distance perception - particularly in tasks that involve movement - Clarke, Pick, and Wilson (1975) present evidence which indicates that intensity may play a role in static distance perception.

By listening for time delays and changes in pitch, impressive feats of surface detection and distance perception may be accomplished. One of the 2 blind participants in Supa, Cotzin, and Dallenbach (1944) was able to detect the presence of a maisonite screen more than 20 feet away much of the time, and the other generally became aware of the screen between five and six feet. All four participants were usually able to move to within half a foot without touching the screen. Figures such as these have been widely replicated under similar procedures involving 27 blind adolescents (Worchel, Mauney, & Andrew, 1950), 20 sighted-blindfolded college students (Ammons, Worchel, & Dallenbach, 1953), three blindfolded adults with progressive vision loss (Juurmaa, Suonio, & Moilanen, 1968; Juurmaa, 1968b), and ten blind children between five and 12 years (Ashemed, Talor, & Hill, 1989).

In a study of motion detection, Juurmaa and Järvillehto (1969; Juurmaa, 1970b) moved 50 centimeter square panels of pasteboard toward or away from 7 blind participants from distances of 70, 120, and 200 centimeters. Levels of performance decreased linearly

with distance. At 70 centimeters, most of the participants detected the target's movement within 20 to 30 centimeters - somewhat more than a third and less than half the total distance. At 2 meters, most participants fell between 70 and 90 centimeter - again, somewhat more than a third and less than half the total distance. These authors found much better performance in a distance recognition task in which these participants had to estimate when a 60 centimeter square metal sheet reached a prescribed distance of 90 centimeters as it was moved toward each participant from a distance of 200 centimeters. Estimates typically fell between one and nine centimeters of the prescribed distance. These results are similar to those found by Kellogg (1962/1964) wherein one of 2 blind participants could perceive a change in distance as little as four-and-a-half inches with a 1 foot wooden disk at about 2 feet away.

Perception of Size

Studies in size discrimination have all followed a similar paradigm - a system of paired stimuli. The smallest and largest in a set of stimuli are presented consecutively where the size difference is greatest and most likely detectable, then the next smallest to the next largest, and so on until the size difference becomes minute. Using this method, studies have generally found size discriminations to be possible at minute thresholds. For example, Rice and Feinstein (1965a; Rice, 1965) found a 95 percent success rate in the ability of four blind participants to distinguish a 10 Mm difference in the diameter of a 90 Mm disk presented at 60 cm distance. Juurmaa and Järvillehto, (1969; Juurmaa, 1970b) found that seven blind participants could reliably distinguish a difference of five square cm in a target of 60 square cm. presented as far away as 2 m. Kellogg (1962/1964) using a slightly different but comparable procedure involving paired comparisons, found that one of 2 blind participants was able to distinguish a 2.5 cm

difference in a 22.5 cm disk presented at 30 cm distance.

It seems clear that size discrimination ability by echo perception involves intensity as a primary parameter. Smaller surfaces reflect less sound, therefore less intensity. In fact, the foregoing studies also demonstrated that size discrimination ability is directly related to the distance of the object. The perceptual discrimination ability of the participants in Rice and Feinstein (1965a; Rice, 1965), fell as distance was increased. For example, at 60 mm, participants were able to discriminate 10 mm changes in a 90 mm disk 95 percent of the time, whereas at 120 mm, their discrimination ability fell to 20 mm changes in a 215 mm disk 90 percent of the time.

Similar trends were found with Juurmaa and Järvillehto, (1969; Juurmaa, 1970b), and Kellogg (1962/1964). Indeed, a study conducted by Clark, Pick, and Wilson (1975) shows the size and distance difference can be difficult to discern from each other. In this study, 12 blind and four sighted-blindfolded

participants were presented with two pipes, one twice the radius of the other, at equivalent and different distances, one twice the other. While the participants could distinguish which pipe was which when presented at the same distance, they could not tell the difference between the small pipe presented at the closer distance and the large presented at the further distance. In theory timbre parameters might also play a part in size discrimination, since higher frequencies reflect from smaller objects more readily than lower frequencies, but the study just mentioned calls the pertinence of this parameter into question. No other empirical evidence is available concerning this matter.

Perception of Shape

In theory, directional characteristics of reflected energy, combined with intensity variations, should allow the perception of shape through the use of echoes. Rice (1967c) found that several blind participants could distinguish a triangle, a circle,

and a square from each other with fair reliability. This ability has been replicated in a later study by Hausfeld, Power, Gorta, and Harris (1982) which involved 18 sighted-blindfolded participants. The trick for both sets of participants involved the generation of an oral signal, and then moving the head so that the emitted sound could be used to trace the edges of the shapes presented. No investigations have been reported concerning the effect of size and distance on shape perception.

Perception of Composition

As indicated earlier, spectrographic analyses of coded, ultrasonic reflections indicate that the ability to perceive object composition through echoes is determined largely by echo timbre - the emphasis and de-emphasis in the return of certain frequencies (Juurmaa & Jävilehto 1969; Juurmaa, 1970b). Different surface textures and compositions seem to reflect certain frequencies better than other frequencies - causing the return of distinct wave patterns that

denote the composite nature of objects. In Juurmaa and Jävilehto's study (1969; Juurmaa, 1970b), echo recognition of texture was examined with four blind participants. Three 50 centimeter square targets of cloth, pasteboard, and metal were individually presented to each participant at a distance of 120 centimeters. Participants were able to recognize the materials as much as 61 percent of the time. Cloth and metal were most easily distinguished from the other materials, while pasteboard proved somewhat more difficult.

These results are somewhat comparable with those of other studies of texture recognition. Using 12 inch disks of different materials presented at 12 inch distance, Kellogg (1962/1964) found that 2 blind participants with reputedly good echo perception skills could readily distinguish between hard and soft surfaces. Wood, glass, and metal, though virtually indistinguishable from each other, were easily distinguished from denim and velvet. Denim and velvet were distinguished from each other 86.5 percent of the time.

In a similar investigation by Hausfeld, Power, Gorta, and Harris (1982) in which 20 centimeter disks of Plexiglas, wood, low pile carpet, and cotton were presented at 25 centimeters distance to 18 sighted-blindfolded participants, the participants quickly learned to recognize the wood and cotton reliably. One blind participant could distinguish wood from cotton with a superior reliability of 90 percent, but, like the sighted participants, was unable to distinguish the other materials.

Object Location

Object location here refers to the horizontal and vertical localization of objects, not the distal location as has already been covered. This ability must certainly arise from the perception of the directional parameters of the reflected energy. Although studies have shown that localization of source sounds is possible in the vertical plane (see Middlebrooks & Green, 1991 for a review), no reports could be found that study the ability to localize

objects in a vertical plane using echoes. Studies have examined object localization in the horizontal plane. Clarke, Pick, and Wilson (1975) found that 12 blind and 4 sighted-blindfolded participants could localize a wide variety of objects in a surrounding space. Rice (1967c) found that two blind participants could localize an 8 cm disk at 1 m distance to within 5 degrees. In later studies involving 5 blind participants (Rice, 1969, 1970) it was found in 11 participants that localization accuracy fell off as the target was moved closer to 90 degrees left or right. These findings seem consistent with some echo detection studies which have shown that detection ability drops off as objects are moved from the frontal position (Kohler, 1964, Rice, 1969, 1970; Schenkman, 1983).

Integrating Echo Perception Variables

In order for echo perception to be of use to the auditory observer, two factors must come into play. First, the auditory observer must be capable of

integrating the echo information about various characteristics of space and objects within space into a gestalt of spatial awareness. "It is one thing to distinguish among a small set of previously agreed targets, and quite another to make out the features of a totally unknown environment." (Mills, 1963, p. 135) In addition, the integration of this information must allow freedom of motion. It must provide an active gestalt that presents continuous, dynamic information about changing relationships between an auditory observer in motion and the complex network of surrounding surfaces. As Rieser put it (1990) "During locomotion, an observer's network of self to object distances and directions changes, and the accuracy of perceptual/motor coordination depends on the precision with which one keeps up-to-date on the changes" (p. 379). Unfortunately, few studies exist that begin to approach echo perception as a dynamic, complex skill.

In the 1960s Juurmaa (1965, 1967a, 1967b, 1969) conducted a series of studies involving over 50 blind participants to determine the relationship between echo perception and spatial orientation ability. The

echo perception tasks involved object detection at different distances, and obstacle avoidance. The orientation measure involved such tasks as having to find one's way back to a starting point after being lead sequitously away, and returning to an original orientation after being spun about. Juurmaa found that echo perception (what he called obstacle sensing) correlated very highly with participants' ability to maintain their orientation. This finding suggests that participants were able to use echo from the walls of the test cite to assist them in their orientation tasks.

Another study (Mickunas & Sheridan, 1963) examined the application of echo perception to the negotiation of an obstacle course. It was found the blind participants encountered much greater difficulty negotiating the course when their hearing was fully blocked than when their ears were free. No such difference was found in a group of sighted-blindfolded controls.

In the mid 1970s, Magruder (1974) investigated the integration of echo information in natural

settings. While this was not a study of motion per sé, such skills of integration would seem highly salient to successful mobility. A blind adult was positioned in about a dozen distinct, outdoor locations - split up between two separate days. The participant was asked to estimate the distance, direction, and height of every object that he could perceive, and to identify each object. Each estimate was compared to discrete measurements. Out of approximately 60 possible objects, distance estimates were off by about 53%, and height estimates by about 47%. Angle estimations were only off about 20% on average, with 54 out of 56 angles estimated to within 5 degrees of true direction. The participant was able to correctly identify 74% of all objects. The accuracy of all judgements fell sharply with increasing distance. For example, distance judgements rose to about 90% accuracy with objects closer than 7 feet. Although judgements were correct as far as 20 feet away, inaccurate judgements seemed most predominant beyond 13 feet. Also, the close presence

of large objects to either side such as buildings made judgements about other objects difficult.

Although the research is scant on this point, it seems likely that the interpretation of echo information can provide a complex, dynamic awareness of surrounding space. Such an awareness would seem invaluable to the process of orientation and mobility. As Ashmead, Hill, and Talor have observed, "... this perceptual ability is manifested in functionally important behavior such as goal directed locomotion, and awareness of the positions of objects in nearby space" (p. 21). If this is so, then it seems essential to examine the conditions under which the interpretation of this vital information can be optimized.

Interpreting Echo Information

If one is to make the best possible use of conventional echoes, the variables involved in maximizing their perceptibility under the widest possible circumstances must be carefully explored.

The degree to which meaningful interpretation of echoes can be made depends on the characteristics of the echo information and the nature of the environment in which it occurs, and the physical and psychological capacities of the observer to perceive and process that information. The signals used to generate echoes are only as good as the observer's ability to perceive the information. The parameters of sound must be interpretable by the observer, or that information is lost or meaningless.

As already noted the human auditory system can receive sounds ranging in frequency from about 20 Hz to about 20 kHz. Within this range, it can distinguish about 1400 steps in pitch. In terms of amplitude sensitivity, the human ear ranges from a sound pressure level of 0.0002 dynes per cm squared and about 130 dB above this, and it can distinguish around 350 steps in intensity within this range (Juurmaa & Järvillehto, 1969; Juurmaa, 1970a). This should speak well for the human auditory system's ability to perceive the subtle nuances of echoes and variations of echo parameters, but the human auditory

system also processes a mechanism that decidedly hampers echo perception - the refractory period. This auditory mechanism attenuates or lowers the ear's ability to perceive a sound about 2 ms after the onset of that sound, particularly where strong or intense sounds are concerned (Wiener, 1980). Thus, the parameters of the signal must accommodate these characteristics of the human auditory system if that signal is to be of use to human auditory observers - namely the blind.

Signal Parameters

Considerable research and some measure of controversy surrounds the application of echo parameters to the elicitation of useful echoes. Different investigations employ different perceptual tests, and measure the results in different ways. Nevertheless, some sense can be made of each set of results if all the information from all sets is carefully considered holistically.

Frequency

Many have argued in favor of the need for high frequencies to carry the most pertinent echo information. Riley, Luterman, and Cohen (1964) found strong positive correlations between mobility performance and frequency sensitivity from 500 Hz to 8 kHz in 27 blind participants. This positive relationship grew stronger concerning frequencies up to 14 kHz in 13 of these participants who were specially selected for high frequency sensitivity. This makes theoretical sense. Though high frequencies don't travel as far as low frequencies, the energy that they carry reflects more completely from surfaces that they encounter. Higher frequencies correspond to smaller sound waves, and small sound waves are necessary for good reflection from small objects and small features of surfaces. This is one of the reasons that bats are able to detect and intercept objects smaller than a millimeter. Ifukube, Sasaki, and Peng (1991) found that even humans could detect and localize acrylic poles as thin as 2 mm when

ultrasonic echoes between 40 and 70 kHz were brought down into the audible range by a down-coding device. For detection of a 17 mm object, 20 kHz wavelengths might be needed for an adequate amount of information to be reflected. Kohler (1964), for example, presents oscillograms which show that a 50 Hz pure tone changes very little in intensity as a 50 centimeter cardboard disk is moved away from it, but the intensity level drops notably when a 1 kHz tone is used, and still further with a 16 kHz tone. Cotzin and Dallenbach (1950) found that only pure tones of 10 kHz could be used to perceive a large obstacle with any reliability. Rice (1967a) points out that 3 of his participants with moderate hearing loss in the upper frequency regions delivered poor performances where small targets and fine discriminations between targets were involved. In an investigation by Ammons and Worchel (1953) of the ability of sighted-blindfolded participants to learn to perceive obstacles while walking, all of the several participants with hearing losses of upper frequencies took longer to learn the task.

However, the role of pitch in the perception of obstacles is more complicated than a simple relationship between wavelength and performance. Rice's participants with hearing deficits, for example, were able to perform nearly as well as unimpaired participants where larger objects were involved (Rice, 1967a, 1967c). Likewise, Clarke, Pick, and Wilson (1975) found that of a group of 16 participants, 2 who were mildly hearing impaired at higher frequencies did not demonstrated significantly poorer performance in the detection of a wide variety of objects. In the Ammons and Worchel investigation (1953) the hearing deficient participants were able to perceive the obstacle as well as the others once they had learned the task. Participants in Supa, Cotzin, and Dallenbach (1944) performed quite well listening through headphones to the experimenter walking toward a wall, even though the microphone had a reported upper frequency cut-off at 9 kHz. Laufer (1946), found that the performance of a sighted-blindfolded participant using an oscillator to detect plywood panels of various widths and heights performed equally

well with frequencies of 250 Hz and 15 Khz. A similar result was reported by Myers and Jones (1958) concerning a blind participant using pure tones ranging in ten steps from 250 Hz to 14 kHz. The ability to detect a 6 by 2 foot target at four-and-a-half feet distance was unaffected by the frequency. Finally, research with bats shows that it is possible for bats, under optimal conditions, to detect a target smaller than the length of the sound waves used (Griffin, 1958/1974/1986). Griffin further suggests that a human using frequencies as low as 12 kHz might be able to detect a wire as thin as an 8th of an inch (3 mm) at close range, even though according to Rice (1967a) the physical properties of this frequency would seem to correspond more suitably to a disk slightly more than an inch (27 mm) across. Investigations thus far have not demonstrated the ability in humans to detect surfaces as minute as Griffin suggests, but Rice, Feinstein, and Schusterman, (1965) did find a few participants able to detect a segment of quarter-inch metal square-rod

at 18 inches distance with the corner or apex of the rod oriented toward them.

In this connection, three investigations have indicated that minimum intensity threshold sensitivity does not have a marked effect on many echo detection tasks. Juurmaa (1965), in an examination of 52 blind participants, found that echo perception correlated much more highly with pitch discrimination ability than stimulus intensity threshold measures from 125 Hz to 8 kHz. Kohler (1964) found in 48 participants that their awareness of fluctuating frequency and intensity correlated highly with the obstacle sense. Kohler (1964) found in an additional study of 267 participants that detection of 50 cm cardboard panels did not correlate with absolute threshold data in tests that ranged up to 8 kHz, or with age in participants 4 to 85 years old. Furthermore, De l'Aune, Scheel, and Needham (1974) found no correlation between age in a group of high school students and elderly veterans, and their ability to detect a T-intersecting corridor. De l'Aune and Gillespie (1974) also found no correlation between

absolute threshold sensitivity up to 8 kHz and the ability of the veterans to perceive the t-intersection (also reported in De l'Aune, Scheel, Needham, & Kevorkian, 1974). These findings concerning age are relevant, because high frequency hearing in the elderly is almost invariably poor compared to that in younger people. From these reports, it appears that the ability to distinguish small variations in sound is more salient to echo perception than whether or not a sound or frequency can actually be heard.

In interpreting these seemingly contradictory results, it must be remembered that different tests of echo perception were performed under different circumstances. Cotzin and Dallenbach (1950), for example, used a dynamic task with the sound transmitted to the participants under highly artificial conditions. All of the other studies were conducted under more natural conditions, and the specific tasks involved have been quite variable. It may simply be that high frequencies are more efficient for performance in some tasks such as the detailed perception of small targets or target features, but

that they are less efficient for performance in other kinds of tasks. Though the processing of high frequencies has certainly shown its advantages, there are considerable limitations as well. The short sound waves that correspond to high frequencies tend not to reflect well from tilted surfaces for purposes of providing clear echo cues. Kohler (1964) found by the use of oscillograms that much less tilt of a cardboard panel was required to negate the intensity fluctuations of high frequency reflections than those of low frequencies. In other words, a slight tilt of the cardboard caused it to disappear from high frequencies, but much more tilt was necessary before the cardboard could no longer be detected by low frequencies. Also, as Kohler (1964) and Juurmaa and Järvillehto (1969; Juurmaa, 1970a) point out, high frequency sounds are much more likely to be obscured or buried by low frequency sounds than the other way around (Wegel and Lane, 1924). This means that echo signals of low frequency may be more effective than high frequencies in situations of high ambient noise such as traffic or construction. Further, pitch and

intensity discrimination, the most salient process enabling echo perception, tends to be poor at high frequencies. Kohler (1964), for example, found that discriminability of sound fluctuations such as those caused by the presence of objects was greatest at about 1.5 to 3 kHz. Lastly, as Kohler (1964) and De l'Aune, Scheel, Needham, and Kevorkian (1974) point out, absolute threshold sensitivity and discrimination sensitivity become poorer with age at the higher frequencies, so it may be fruitless for older people to try to depend solely on high frequency information for echo perception.

The effective use of midrange frequencies does not seem unreasonable when one considers that orientation and mobility rarely requires the need to detect the minutest of objects. A recent study conducted by W. Wiener (personal communication, May 24, 1995) found in 10 blind participants that a variety of mobility skills relied most predominantly on perception of midrange frequencies. Griffin (1958/1974/1986) and Rice (1967b) nevertheless argue compellingly that the echo image of the environment is

made sharpest and clearest by the emission of higher frequencies. Further, Wiener (1980) points out that frequencies from about 2 to 4 kHz are most difficult to localize. Laufer (1946) reports the worst performance for a sighted-blindfolded participant at frequencies of 1 and 4 kHz as did Cotzin and Dallenbach (1950). This finding was not replicated by Myers and Jones (1958) with their blind participant, but their's was an entirely static task of presence vs. absence detection, while those of Cotzin and Dallenbach (1950), and Laufer (1946) were dynamic tasks wherein participants made judgements of obstacle distance and location as they walked. It may be that simple detection of medium or large obstacles is little effected by frequency, but that more complex tasks such as localization and location are.

In any event, where frequency alone is concerned, the disparity between assets and liabilities seems irreconcilable. Yet, frequency is only one parameter of sound. The picture is made gradually clearer by examining the other parameters.

Timbre

Studies of timbre seem to agree that complex, wide band timbres yield more useful echo information than simple wave forms of narrow band. When comparing the use by a sighted-blindfolded participant of a buzzer vs. pure tones ranging from 250 Hz to 16 kHz as source signals, Laufer (1946) found that the buzzer allowed fewer collisions and more detections of various sized panels at further distances than did the pure tones. The participant also reported that the buzzer was easier and more pleasant to work with. Dallenbach and his associates found performance with pure tones transmitted to participants through a microphone and headphones to be greatly inferior to footsteps (Supa, Cotzin, & Dallenbach, 1944) and wide band noise (Cotzin & Dallenbach, 1950). Finally, Kohler (1964) found that oscillograms of pure tones vs. white noise aimed at a receding cardboard panel clearly show intensity decreases that are much more marked with the noise than the tones. Kohler explains that the advantage of complex over simple timbres

probably lies in the fact that they combine properties of many frequencies into one composite signal. This elicits the sharp detail that high frequencies afford while allowing maximum intensity discriminability with the midrange frequencies that occur simultaneously. In this connection, it is also known that mid to low frequencies travel furthest, and therefore may allow for the greatest distance perception (W. De l'Aune, personal communication, May 26, 1993). Moreover, Kohler (1964) goes on to point out that different surface characteristics in different environments reflect different wavelengths. A composite or complex signal would ensure that the greatest amount of information is made available under the widest variety of circumstances. Using a complex timbre, then, it seems clear that the auditory observer can effectively make use of whatever set of frequencies that will yield the best information in the current situation. Bats accomplish this both by using complex tones, and by sweeping their signals across a wide band of frequencies (Griffin, 1958/1974/1986). They also vary the frequencies that they emit depending upon their

need - using frequencies between 30 and 50 kHz for orientation and cruising flight, and between 40 and 70 kHz for the interception of tiny targets (Griffin, 1958/1986).

Intensity

Twersky (1953) has reported that sounds of medium intensity yield better object perception than sounds of high intensity. On the surface, this would seem counter-intuitive, since louder sounds should produce louder and therefore more audible echoes. There are two factors, however, that explain why very intense sounds may not allow good echo perception.

The first involves the fact that echo information is always much quieter than the sound or signal that produces it - particularly echoes from small or far away objects. If the signal is too loud, the echo cannot be heard over the volume of the signal. The signal blots out the echo; it is said to "mask" the echo.

The second issue is more complex. It has to do with the auditory constraints of the echo observer. In the case of humans, there are mechanisms in the auditory system, namely the stapedious reflex and the neural refractory period (Wiener, 1980), which dampen reception immediately after the beginning or onset of a sound. This means that a sound seems to get quieter right after it starts - particularly very loud sounds. The actual intensity of the sound does not change, just the perception of the intensity. These mechanisms serve to protect the ear from damage resulting from very loud sounds, and also to increase speech intelligibility by causing each phonetic articulation to seem discrete and somewhat distinct from the others. Otherwise, all speech would seem to blur together. Unfortunately for the human echo user, these sound dampening mechanisms tend to diminish the extent to which echoes - which always occur after the onset of a sound - can be received and processed.

In view of these problems, it is essential that other parameters be considered carefully so that a

maximum of useful echo information is made available to those who need it.

Envelope

In order for a signal to elicit useful echoes, it should allow the majority of the echo to be heard by the echo observer. Twersky (1951a) and Kohler (1964) report that signals of brief duration (pulsed signals) were more pleasant to work with, and enabled better object localization than signals of lengthy duration. Shortening the duration of the signal gets the signal out of the way quickly so that the echo information can best be heard. If a signal is intense but over very quickly, the echo information returns after the pulsed source signal is finished, and is therefore not masked by the source signal. The echo may still be somewhat suppressed by dampening mechanisms in the ear, particularly if the source signal was very loud, but the shorter the signal, the more audibly clear the echo will be in any event. Griffin (1958/1974/1986) suggests that a pulsed signal of less than 10

milliseconds duration would be optimal for good echo perception in humans. He points out that bats often use pulses of less than one millisecond.

In addition to short duration, there is good theoretical support for the use of a signal with a very rapid rise and/or decay time (W. De l'Aune, personal communication, May 6, 1993). A signal with a rise time of under 2 milliseconds, for instance, generally yields a special component of complex frequencies that may extend high into the spectrum. This is called a "click transient". It amounts to a very brief burst of white noise at the rise time of the signal which can yield very high frequencies depending on the physical nature of the signal. Even if the signal itself is only comprised of low frequencies, a very quick rise and/or decay time provides a complex spread of frequencies to a very high range. This is significant, because many useful signals for echolocation such as finger snapping or tongue clicks (discussed later) would not contain high frequencies if it were not for their quick rise and

decay. There are, however, two investigations that call the supremacy of pulsed signals into question.

Rice (1967b) found no differences in performance at most tasks between participants who used orally produced click vs. hiss signals. These findings held when oral signals were substituted for electrically generated clicks of 4 milliseconds duration, and electrically generated white noise, except that participants tended to do better with the artificial signal that most resembled their orally produced signal. However, in a shape recognition task involving several blind participants, those using an orally pulsed signal such as a tongue click did somewhat worse than the one participant who used an oral hiss sound. Rice conjectures (1967b) that the use of a continuous signal allowed the participant to trace the edges of the target more effectively than with successively pulsed signals like those used by the other participants. Unfortunately, Rice does not provide specific data as to the types of tongue clicks used by his participants, except that they had slow rise times, and ranged from about 25 to 75

milliseconds in duration. Also, it should be noted that the participant who did so well on the shape discrimination task by using a hiss signal later indicated that he might have improved his performance on distance perception and size discrimination tasks if he had used a tongue click instead (W.A. Gerrey, personal communication, April 12, 1993).

With five blind participants Schenkman (1985a) compared electronic clicks of 1.5 milliseconds with white noise signals of one second in detecting a two by one-half meter maisonite board at distances of one, three, and five meters. The white noise was generally found to be somewhat superior, but these results are not clear. The difference seems dependent on individual participant performance and the distance to the target. One participant showed better performance with the click signal, and, interestingly, this one was the most proficient of the five at object detection for all distances. Perhaps the more proficient one is at echolocation, the better use one is able to make of ideal information and optimal cues.

Directionality

In order for a signal to elicit useful echoes, it must allow the greater portion of the reflected energy to return to the ears of the echo observer. For purposes of echolocation, directionality can be divided into two related components with respect to the ears of the echo observer - the primary direction of the source signal, and the primary direction of the reflected energy.

Concerning the direction of the signal, Laufer (1946) and Twersky (1953) found highly directed signals to yield better performance than undirected signals. Directed signals should be most useful, because the primary energy of the signal is focussed away from the ears of the echo observer. The signal remains the same volume as if it were undirected, but the ears receive it at a lower intensity because most of the signal's energy is directed away - much as the sound of a trumpet seems quieter when standing behind the trumpeter than directly at the mouth of the trumpet. By thus shielding the ears from the primary

energy of the signal, a more intense signal may be used to elicit strong echoes. These echoes are then quite audible, because the ears are shielded from the bulk of the source signal's energy, and therefore more exposed to the reflected energy.

The primary direction of the reflected energy is determined by the direction of the source signal relative to the reflecting surface or surfaces (Wilson, 1967). In turn, the degree of reflected energy reaching the ears of the echo observer depends upon the relative position and orientation of the observer's ears to the position and direction of the source signal and to those of the reflecting surfaces. Thus, a signal emitted at or near the ears of the echo observer and directed at a perpendicular surface would be expected to yield the strongest and most detailed perception of that surface.

Two investigations into this relationship have found mixed but interpretable results. Schenkman (1983, 1985) studied the effect of object detection with the object and echo signal varying in their locations with respect to the listener.

In the first study (1983) Schenkman found that, using cane taps, a group of 6 blind participants was able to detect a small target placed in front of them much better than a group of 4 blind participants to whom the target was presented to either side. Also, this group of 6 was able to detect a 38 cm aluminum disk more easily with vocal signals such as clicks and hisses than with cane taps. This later result finds corroboration with a later study by Schenkman and Jansson (1986) of the effectiveness of different types of cane taps in producing echoes. In this study, the authors had to exclude the data from one participant who would not refrain from using tongue clicks, and whose scores were well inflated above those of the other participants. While cane taps and hisses share few spectral characteristics, the spectral characteristics between cane taps and tongue clicks are not dissimilar (Ladefoged & Traill, in press; Schenkman & Jansson, 1986). Taking these two findings together, it seems fairly reasonable to attribute a large portion of the discrepancy in performance to the different relationships between echo signal, target,

and observer. When targets were presented to the side rather than in front, much of the acoustic energy radiating from the cane taps simply missed the target allowing little energy to be reflected. When the target was in front, much more of the acoustic energy struck the target, and was, therefore, returned. When signals were produced vocally, the amount of reflected energy was further increased. The acoustic energy traveled more or less straight from the participant's head, struck the target, and returned more or less directly to where it originated. When canes were used the acoustic energy followed very different lines. It radiated in all directions from the cane tip - sending only a small portion to the target located somewhere above the source. The angle at which the acoustic energy struck the target was oblique, causing that energy to bounce off obliquely. As in the experiment wherein targets were presented laterally, relatively little of the reflected energy would ultimately have reached the ears of the observer. This interpretation is somewhat born out by an additional study in this investigation. Using cane taps only, 8 blind

participants were able to detect a small target more easily when it was presented at waist level than at head level. In this scenario, the acoustic energy emanated from the cane tip as before, but much more of it struck the target in the lower position than in the higher position. Thus, more of it had an opportunity to reach the ears of the participants. In fact, detections of the lower target were even a little better with the target 3 m away than 1 m away. With the closer distance, it seems that much of the acoustic energy passed beneath the target, and could, therefore, not be reflected. When the target was further, the path of travel of the acoustic energy was more direct, since the angle between incident and reflection was wider. These findings bare resemblance to those of Clarke, Pick, and Wilson (1975), who found in a study of 16 participants that detection of curbs less than 20 cm high became nearly impossible when the curbs were less than 50 cm away.

A later investigation by Schenkman into the issue of directionality (1985) found results which seem on the surface to contradict those just explained. This

investigation examined the ability of 5 blind participants using artificial signals originate at head, waist, and ground level to detect the presence of a target. The target measured 2 m tall x 0.5 m wide, and was presented at 1, 3, and 5 m distance. For all distances detection reliability was highest when the signal originated from the waist, and lowest when the signal originated from the head. This would seem contradictory to both theoretical predictions and empirical findings, but two factors must be considered. First, this report does not make clear the directional characteristics or volume of the signal. It may be that the signal, when presented too near the head, served to mask or otherwise dampen the perception of returning echoes. Also, and perhaps more importantly, the nature of this target was different from that used in other studies. The other targets were quite small - occupying only a small region of vertical and horizontal space. They were especially susceptible to acoustic energy passing around or beneath them. The target in this later investigation was quite tall and relatively wide.

Though the patterns of returning acoustic energy differed depending on the location of the signal, signals aimed at the target from any vertical position always struck the target. In this scenario, the least energy striking the target would emanate from the head position, since much of the energy would pass over the target. Signals presented from the ground might have been largely absorbed or deflected from the target by the ground. The location offering the most returned energy would logically have been the waist where energy would not pass too freely over the target, or be deflected from it.

Signal Consistency

In discussing the conditions that optimize echo perception, a brief note is needed concerning the consistency of a signal. Rice (1967a, 1967b) found that blind participants were able to use a variety of artificial signals to accomplish given tasks, but performance was always highest when those signals resembled those to which they were accustomed through

long, previous practice. This is an important consideration, because echoes are elicited to varying degrees by just about anything. It behooves a blind listener to know what signals can be relied upon for the best information. For this, it would seem reasonable to suppose that familiarity with the use of certain combinations of parameters would increase the reliability of such a signal. If the blind observer should be inclined to elicit echoes by deliberate means, it would seem prudent to develop such a familiarity.

The Ideal Signal

The ideal signal should quickly and easily provide useful information about the greatest variety of objects and surfaces under the widest possible circumstances - noisy or quiet, cluttered or open. It should be clear from the foregoing discussion of signal parameters that it is fruitless to consider a single parameter isolated from all other parameters, since all integrate to provide optimal conditions for

echo perception. Taken as a whole, the ideal signal would incorporate acoustic parameters that make use of frequencies throughout the audio spectrum, and maximize the return of echo information to the ears. A pulsed, directed, complex signal of variable intensity originating near the ears appears optimal. Further, the signal should be an active or deliberately produced signal that is relatively consistent in its acoustic characteristics.

Active signals fall into two categories - artificial and organic.

Artificial signal production requires the use of an external signaling device. Such devices tend to be cumbersome and obtrusive. They typically require an off hand to operate, and the noise they emit calls attention to the user (Beurle, 1951; Greystone & McLennan, 1968.) However, producing signals by artificial means can offer the advantage of allowing signal parameters to be designed with precision to optimize echo information. Signals designed by electronic or mechanical means can incorporate many of the optimal characteristics.

Many types of electronic have been used for echo perception including buzzes and high frequencies (Cotzin & Dallenbach, 1950; Laufer, 1948; Myers & Jones, 1958; Witcher & Washington, 1954), pulsed and continuous white noise (Clarke, Pick, & Wilson, 1975; Cotzin & Dallenbach, 1950; Mills, 1963; Rice, 1967a, 1967b; Schenkman, 1985a), and transient clicks (Beurle, 1951; Greystone and McLennan, 1968; Rice, 1967a, 1967b; Schenkman, 1985a, 1985b). Electronic generation offers the broadest flexibility in signal design, but this method of production tends to be costly, and requires a power source and periodic maintenance.

Mechanical devices typically take the form of snappers and clickers. Such devices have been used occasionally to train the blind in echo perception. The first was developed by Griffin in 1944 (Witcher & Washington, 1954). It was a metallic snapper housed in a parabolic shell to focus the sound and direct it away from the ears, and it was used successfully to train blinded veterans. A similar but smaller device was developed by Twersky in the 1950's (Griffin, 1958/

1974/1986), and found similar success. Recently Boehm (1986), found that five blind participants could use a hand-held clicker without prior training to correctly identify most of 25 features in a 160 by 20 foot hallway. The particular clicker that they used is marketed in the form of toys shaped as frogs or insects. Mechanical devices such as these are less costly than electronic devices. However, they require frequent maintenance or replacement, and they can not be designed with maximum flexibility. User control over intensity, for example, is typically limited. Furthermore, in the most portable, least cumbersome devices, the emitted signal is not well focused.

Cane taps and footsteps might fall into the category of mechanically produced sounds. While possessing none of the disadvantages of other forms of artificial signal production such as expense, maintenance, etc., they do not necessarily possess any of the advantages either. While such signals can facilitate echo perception (Schenkman, 1983; Schenkman & Jansson, 1986; Supa, Cotzin, & Dallenbach, 1944), neither cane tips nor shoe soles have been designed to

optimize echo information. In particular they are nondirectional, they occur far from the ears, and the spectral components cannot be effectively optimized.

Organic signals hold few of the disadvantages of artificial production. They need not require extra manipulation, they are always available to the user, they need not be cumbersome or unwieldy, servicing requirements are minimal, and they are free. They may not offer the flexibility that electronic signals may deliver, but organic signal generation does constitute a broad array of parameters nonetheless.

Blind echo users are known to generate a wide variety of organic signals from hand claps and finger snaps, to vocal and oral signals. Hand clapping and finger snapping have the advantages of strong intensity, medium spectral complexity, and quick onset and duration, but these signals are unfocused, and require the use of the hands which are often not conveniently available. Oral signals, on the other hand, require no extra manipulation, are highly directional, and are quite flexible.

The most common type of signal referred to in the human echolocation literature is the oral click. Nearly every work that deals with echolocation in the blind mentions the oral click as a common signal (e.g., Kellogg, 1962/1964; Magruder, 1974; McCarty & Worchel, 1954; Myers & Jones, 1958; Rice, 1967a; Schenkman & Jansson, 1986). Information is rarely provided as to the type of click, but the scant information that is available suggests that a variety of clicks are used. Jones and Myers (1954) and Myers and Jones (1958), for instance, mention "lip clicks", and Rice (1967a; 1967c; circa 1970) indicates that the tongue clicks used by his participants varied in duration from about 25 to 75 milliseconds. McCarty and Worchel (1954) who studied a blind boy's ability to ride a bicycle with great facility, indicate that the click that he used to accomplish this feat resembled that of a toy cricket.

Phoneticians classify oral clicks into five distinct types according to how the click is physically produced (Ladefoged & Traill, in press). Each type of click has different envelope, intensity,

and spectral characteristics. Theoretically, clicks in general should form good signals for eliciting echoes, and empirical evidence demonstrates that they are used effectively (Rice, 1967a, 1967c). They are fairly intense, of short duration, complex, and directional. Ladefoged and Traill show clicks to be more intense than other normally spoken sounds. In addition, these authors report a study in which 10 native speakers of African dialects found tongue clicks to be more easily distinguished than other consonants from a background of white noise presented through headphones. These findings hold special significance to echo users in light of a study by Kohler (1964) which showed that high background noise drastically reduced echo performance for 20 participants. It is clear that an echo signal must possess sufficient intensity and uniqueness to elicit echoes that are distinguishable from background noise. Depending on the oral click used, spectral frequency is reported to vary from about 0.9 kHz to about 8 kHz. Rise times range from about 1.2 ms to

about 8 ms, with duration ranging from about 6.6 ms to about 20 ms.

Theoretical considerations would implicate the click with the sharpest rise time, shortest duration, greatest intensity, and highest mean frequency as having the greatest utility for echo perception. However, little empirical evidence is available on this point. In fact, the only study that may be applicable does not actually examine differences between oral clicks, but rather differences between the spectral characteristics of taps from different canes (Schenkman & Jansson, 1986). With 2 blind participants no differences were found in an obstacle detection task relative to the differing spectral characteristics of 10 distinct canes. Hard conclusions regarding the relationship between spectral characteristics and echo performance are impossible to draw from this study. It may be that spectral differences in echo signals must be greater in order for impact on echo performance to be appreciable. Or, much more sensitive measures of performance may be necessary to find differential

impact. Spectrograms presented in this report do not bare striking differences to those of various oral clicks (Ladefoged & Traill, in press). If broader spectral differences in echo signals are necessary for echo performance to be appreciably affected, than the use of different oral clicks may result in little variation in performance.

Generally speaking, the pulsed, complex, and directional nature of oral clicks would seem to make them highly effective echo signals. The spectral and parametric differences between them may further enhance their utility. The control of parameters such as intensity, timbre, and directionality make oral clicks easily adjustable to fit the requirements of varying situations. An increase in intensity, for instance, can help cut through heavy ambient noise so that echoes from distant objects may be elicited and perceived. Decreasing intensity may be needed to eliminate extraneous echoes in highly reverberant environments, or to keep the click unobtrusive in quiet, close environments where others do not wish to be disturbed. Its direction may be focused downward

to locate curbs, steps, or grass lines, or focused upward for overhangs. If the effective use of echo perception is to be optimized by an active signal, there is good reason to consider the oral click as a prime candidate.

While oral clicks have not been directly compared to other sounds in terms of effectiveness, an excellent example of their use can be found in the oil bird which, according to Griffin, skillfully navigates the absolute darkness of deep caves (cited in Witcher & Washington, 1954). These authors report that the acoustic parameters of the click produced by the oil bird strongly resemble those comprising oral clicks commonly produced by humans. Among humans McCarty and Worchel's (1954) examination of a blind boy's bicycling skill serves as a most impressive demonstration of echo-mobility by oral clicking. Likewise, the man shown bicycling at moderate speeds through complex and unfamiliar terrain emitted intense, sharp tongue clicks with a frequency of more than one per second. When interviewed this man said that his click was essential to his bicycling ability,

and integral to his mobility skill. While the environmental demands on a blind human probably surpass those of the oil bird by a fair margin, the preponderance of theoretical support and empirical evidence, together with apparent examples of success, point to the oral click as useful in facilitating the mastery echo perception.

ACQUISITION OF ECHO PERCEPTION SKILL

Studies of hundreds of humans strongly suggest that all hearing persons can learn to perceive and interpret echoes to some degree - either by active or passive learning. It is not, as once believed (Hayes, 1938), a special endowment that may be appreciated by only a fortunate few. In fact, though it is commonly found that the ability to perceive and interpret echoes is highly variable among the blind, it has nevertheless been shown to manifest to some degree in the majority, and to a remarkable degree in many. In a study of 52 blind participants in Helsinki Finland, for instance, Juurmaa (1965) found 87 percent able to

demonstrate some ability to sense the presence or absence of panels of various sizes at various distances, and six of these showed perfect performances at a distance of 2.5 meters.

Although few investigations have been reported concerning the specifics of training echolocation, most investigations have indicated improvement in the participants studied regarding the given task. Training and practice trials are common, and always show improvement. For example, Hausfeld, Power, Gorta, and Harris, (1982) report considerable improvement for all 18 of their sighted-blindfolded participants on both the shape and texture discrimination tasks. Magruder (1974) found that, in a two day study of distance, direction, and object perception, her participant improved estimates of distance improved over 38% from one day to the next given practice and feedback.

Those investigations that do specifically examine the issues behind training echo perception have generally found very positive results. Among the first of these can be attributed to Worchel and Mauney

(1950) who studied the effects of practice on the ability of seven blind children to perceive a maisonite boarder like that used by Dallenbach and his associates (Supa, Cotzin, & Dallenbach, 1944). The procedure was also the same as in the Dallenbach studies, with first perceptions and final appraisals of target distance being used as indices of perception, together with frequency and force of collisions. Initially, participants' perceptions of the target were erratic and inconsistent. Collisions were frequent and forceful. Over the course of 210 trials spread over four days, all participants showed markedly increased consistency in the perception of target proximity. Final appraisals dropped from as high as 150 cm down to less than 30 cm for all participants, and the frequency of falsely perceiving the target also decreased by more than 75 percent. Frequency of collisions between the pre- and post-test runs decreased from 56 to 19, and the force of collisions decreased very markedly as well. All of the participants showed the majority of their

improvement over the first 30 to 60 trials, indicating an asymptotic learning curve.

The asymptotic nature of echo training was replicated a few years later by Ammons, Worchel, and Dallenbach (1953). This experiment involved 20 sighted-blindfolded participants, and used the same classic procedure as in other Dallenbach studies. Again, participants' ability to localize the target and avoid collision with it decreased substantially over the course of a few day's practice. With these participant, however, progress was quite slow for the first few trials, then, picked up suddenly. Participants indicated a sudden awareness of the parameters of the task - of what to pay attention to and how. Once this insight was achieved, learning progressed rapidly before tapering off. These trends are similar to those found by Kohler (1964) in which 20 participants learned to increase their ability to judge distance over a six week training period.

Juurmaa, Suonio, and Moilanen (1968; Juurmaa, 1968b) trained three individuals with progressive vision loss in several skills areas - avoidance of

different sized and multiple obstacles, and determination of height and breadth. The participants walked down a path on which one, two, or zero obstacles of varying size were placed. The participant was instructed to indicate when he first perceived each obstacle, to stop 0.5 m before reaching the obstacle, and to provide an estimate of the obstacle's dimensions. Sessions ran about 30 minutes a day for four weeks. Participants learned to avoid collision quickly and in a similarly insightful manner as previous studies have demonstrated. However, first perception increased more evenly and gradually over the course of training. Perception of dimension was the most difficult skill of all to learn. While there was improvement for all participants in all skill areas, it was noticed that the participant who had the best initial performance made the least progress relative to the others. It would seem that those who have less to learn, learn less.

This phenomenon was born out in a study by Greystone and McClennan (1968) of 26 blind children. Participants were instructed to navigate an obstacle

course with the assistance of an electronic clicker. The obstacle course consisted of a series of walls with an opening at a different point along each wall. The effect was a maze of off-set openings through which the participants had to traverse. After the participants had completed the task, they were given the electronic clicker, and told to practice at home over the summer. When the school year resumed, the children were tested again. It was found that participants who had done well to begin with did not improve, but those who had done poorly to start with improved markedly. Collisions and hesitant stops were reduced by about 50 percent, and time to complete the course was reduced by about 16 percent. No data were available regarding the nature of practice that took place over the summer.

Finally, Clarke, Pick, and Wilson (1975) studied 16 participants in a course of training to improve participants' ability to negotiate a complex obstacle course with and without the use of a signaling device. Forty minute training sessions took place twice weekly for eight weeks. Participants were

introduced to a variety of object perception tasks involving a diversity of objects including curbs, furniture, pipes, etc. For example, in one task, participants were asked to rotate about a room full of objects, and describe any object they sensed around them. Feedback was provided regarding accuracy. All participants improved on all tasks with and without the signal generator between re- and post-assessments of skill.

The research is clear that anyone with normal hearing can learn at least basic echo perception, and many appear to be able to learn more complex skills as well. Moreover, much insight into how echo perception might best be learned can be gleaned from this information. If echo perception can be passively or actively learned under appropriate conditions, then it stand to reason that, given the right conditions, echo perception can be actively taught.

Developing A Training Program

The research to date yields clues that can be used to facilitate the development of an echo perception training program. The primary issues include what needs to be taught, and how is the teaching to take place.

In order for a training program to be worthwhile, it must be practical. Exploring the limits of echo perception and establishing psychophysical measurements certainly has its places, but if a training program cannot teach perceptual skills that will apply to the enhancement of a person's functioning, that program has little immediate, practical utility.

The most useful application of echo perception for a bat is in the facilitation of its ability to survive - i.e., to hunt, roam, and find shelter. Analogously, the same may be said for humans. In order to survive, people must be able to meet their needs, or see that their needs are met. One of the most instrumental aspects of this process involves the

ability to transport oneself from one place to another. The inability to move can be said to sharply curtail a person's ability to obtain and maintain needed resources. Therefore, an echolocation training program should hold its primary focus on the development of skills that will enhance mobility.

Two key aspects of mobility may be argued - security, and efficiency. According to Jansson, (1989), the process of blind mobility can be divided into two functions: walking toward, and walking along. Walking toward involves the process of maintaining one's orientation toward a goal. This may be a proximate or distance goal. Walking along refers to the on-going process of controlling one's locomotion - processing environmental features and acting in accordance with them.

The ability to maintain one's orientation and good control over one's locomotion constitutes efficient travel, but efficiency must also mean security. Studies in blind mobility have pointed to three factors that constitute secure travel (Leonard, 1972; Armstrong, 1975): the ability to stay on a path

without accidental departure, the ability to avoid bodily contact with objects, and the ability to cross streets quickly and directly without incident. Barth and Foulke (1979) discuss variables of security and efficiency in terms of "preview" - the ability to adequately perceive the features of an environment in advance of one's position. They argue compellingly that advanced awareness allows for effective planning and appropriate responses to conditions ahead.

Given these elements, it seems reasonable that, if an echo skills training program is to be practical, it must develop skills that facilitate the maintenance of orientation, the ability to negotiate and avoid objects, and the ability to control locomotion through near space by the use of proximal cues such as guiding features (walls, borders, building lines, etc.)

Although there is some president for the inclusion of echo perception into mobility curricula (Amendola, 1991; Wiener, 1980) very few specific techniques for teaching are available. It is clear that development of echo skills can occur through practice and feedback, but that's about all that is

clear. The development of specific training techniques is, therefore, much needed, and wide open.

In devising techniques for training echo skills, it would seem essential to keep in mind the unique needs of the population being served. For example, while deficits in spatial awareness and comprehension are not necessarily pervasive among those blind early in life (Jones, 1975; Loomis, Klatzky, Golledge, Cicinelli, Pellegrino, & Fry, 1993), they are, nonetheless, irrefutably common (Hart, 1980; Hill, Rieser, Hill, Hill, Halpin, & Halpin, in press; Warren, Anooshian, Bollinger, 1973). It is, therefore, necessary that a program specializing in the apprehension of space be sensitive to such issues. For example, many of the blind, particularly the young, establish manual groping or sweeping gestures that are fundamental to object contact or acquisition (Martinez, 1977). In the preliminary implementation of an echo training program, it may be necessary to devote some attention to the instruction of directed reaching for some students, or to design alternate exercises that do not require reaching

responses. Moreover, head centering is often not found in the blind, particularly the early blind. They often tend to orient their heads obliquely to sound, favoring one ear. Other postural anomalies are also common (Martinez, 1977) which may make head orientation difficult. Head pointing responses may not be appropriate at first. It may be best to instruct students to turn their chest or back to the relevant stimuli by way of response.

Another aspect in which instruction must be sensitive to student factors concerns age. It seems reasonable to suppose that different skills might be appropriate to different ages, and that forms of instruction would have to vary in order to optimize instruction to a wide age range. For example, younger students may not possess a grasp of basic spatial concepts such as right vs. left, above vs. below, near vs. far, and so on (Garry and Ascarelli 1960; Warren, 1989). Some blind children may not understand "facing" or "reaching for" something, or their performance at such tasks may simply be poor. Juurmaa (1967a, 1967b) indicates that development of spatial

skills continues to occur after the age of 10. Techniques should be designed to at once circumvent and develop comprehension of such spatial concepts. For example, spatial terminology (right, left; up, down; near, far; etc.) may be used in conjunction with tactual cues (touching corresponding body part - shoulder, top of head, leg, etc.) and interaural and distal cues (positioning experimenter's voice in space to correspond to spatial vocabulary). For some students in the beginning, it may also be helpful to pair source sounds with echo stimuli. A student may find it easier to respond to something that seems more concrete by its source noise than abstract by its reflective properties. Though echo perception alone tends to be a phenomenon that is consciously "felt" more than "heard", echo users nonetheless use auditory scanning techniques for orientation (Kellogg, 1962/1964), so skills learned in this way may generalize with practice to genuine echo tasks. They may also help to acquaint students with lesson parameters and procedures.

STATEMENT OF THE PROBLEM

Although the specific mechanisms underlying the technical aspects of echolocation in humans have been fairly well studied and are well understood, particularly concerning blind humans, no systematic study of comprehensive training for complex echo-mobility has been reported. Most of the studies in this area are based on simple trial and error methods that concern very basic skills. They may address the question of whether or not echo perception can be learned, but they fail to examine the application of these skills to complex mobility, and they do not address the question of how such skills should be actively taught for optimal effect.

This study seeks to explore these avenues through the implementation of a pilot program of echo instruction. It is hoped that this program will allow the collection of comprehensive qualitative and quantitative data relevant to the teaching of echo skills. It is further hoped that such information will enable the establishment of stronger, more

effective programs of echo instruction. To provide a basis for understanding the functional use of such a program, this study tests the hypothesis that two key aspects of mobility - straightness of course and target location - will improve through systematic, comprehensive training.

METHOD

Participants

The study involved a total of 23 blind youth - all of whom were partly or fully mainstreamed in Southern California public schools. There were 11 boys and 12 girls ranging in age from about 4.5 to 15 years.

Participant Groupings

This study implemented a pre-treatment/post-treatment assessment. Due to a variety of problems, however, 11 of the participants were not post-assessed. Therefore, in analyzing the participants and interpreting the results, the participants are considered in two groups - pre-assessed only, and post-assessed. Background characteristics on these participants are presented for each group.

Background Characteristics

All medical information was taken from school records, and confirmed or elaborated upon (when possible) by personal observations and observations by their instructors and parents.

Degree and Style of Blindness

All participants were educationally blind. Since the onset of blindness, their vision had been of no functional use to them in their studies. All were braille and cane users. All of the participants' visual acuity fell below minimal visual acuity measurements, and none of them possessed any perception of color beyond gross contrast discrimination.

Four of the pre-assessed only and two of the post-assessed participants were totally blind. They had no perception of light whatever.

Three of the pre-assessed only and eight of the post-assessed possessed nonfunctional light

perception. They were dimly able to see very bright light sources at close range, but they could not tell the location of these sources. They could not see objects no matter how large, close, or brightly illuminated.

Two of the pre-assessed only and one of the post-assessed possessed light projection and gross form perception. They were dimly aware of the direction of very bright light sources, and could see the presence of large objects at close range. They could not see physical detail or shading contrasts.

Two of the pre-assessed only and one of the post-assessed possessed light projection with gross visual perception of movement, form, and shading contrasts. At close range they could see vague outlines of large objects, and could glimpse bright or dark hues against dull or light hues. For two of these participants (one from each group) forms were often easier to see from the side, and if they were moving.

Cause of Blindness

Although a large percentage of participants in both groups seem to have lost their vision through retinopathy of prematurity, a wide variety of etiologies are represented overall. The table below delineates the number of participants in each group who lost their vision due to specific causes.

Age of Onset and Duration of Blindness

The onset of blindness occurred during the first six months for nine of the 11 participants who were pre-assessed only, and 11 out of 12 participants in the post-assessed group. Two of the three total exceptions (both pre-assessed only) are believed to have had very poor vision even from birth. One of these lost his vision gradually from infancy; the other had received a surgery during infancy which improved his vision markedly for a few months. No details of this procedure were available. The third

Table 1

Count of Students With and Without Post-Assessment Scores for Different Causes of Blindness.

<u>Pre-Assessed Only</u>	<u>Post-Assessed</u>	<u>Cause of Blindness</u>
4	6	Retinopathy of Prematurity (ROP)
1	2	Optic Nerve Hypoplasia
0	1	Septo-Optic Dysplasia
0	1	Congenital Glaucoma only
1	0	Congenital Glaucoma with Cataracts
1	0	Retinalblastoma
0	1	Removal of Brain Fortummor
0	1	Maternal Rubella
1	0	Congenital Retinal Detachment with Cataracts
1	0	Lieber Syndrome
2	0	unknown

participant (post-assessed) had been fully sighted until the age of 6.

Since blindness occurred during infancy for most of the participants in both groups, the duration of

blindness closely follows the chronological age of most of the participants.

Chronological Age and Gender

At the beginning of the program, those participants who completed the pre-assessment only ranged in age from four years eight month to 15 years plus with an average age of about nine years. Those who were post-assessed also ranged in age from five years ten months to 11 years - averaging about eight-and-a-half. Of those pre-assessed only there were six girls and five boys, while the post-assessed group held six of each.

Additional Handicaps

With one exception, no physical handicaps besides blindness were present. This exception involved a mild hearing loss throughout the mid-range frequencies in both ears. This hearing loss was not diagnosed until after the beginning of work with this

participant, and this participant was not post-assessed.

No diagnosed mental handicaps were present. However, two of the participants functioned two grades below level at the age of ten. In addition one 6 year old has experienced unusual difficulty maintaining attention, and acquiring sequential skills such as braille reading, counting, and retaining verbal instructions. A psychological assessment was pending. All three of these participants were post-assessed.

Level of Mobility Skill

Mobility competence varied widely from extremely high to very poor in both groups. The two highest functioning participants were able to travel independently in unfamiliar environments with grace and security. These two were 11 and 12 years old, and were not post-assessed. The highest functioning participant who was post-assessed was nine years old. He required some assistance to learn unfamiliar

environments, but learned them very quickly and eagerly. The lowest functioning participants in both groups were barely mobile in unfamiliar areas, and required much assistance, time, practice, and encouragement to learn them.

Apparatus

The apparatus consisted of an assortment of simple and complex stimuli designed from a great many materials. (See Appendix B for a comprehensive list of materials and measurements.)

Stimuli

Most of the stimuli were constructed from Plexiglas panels. These panels were fastened together into different configurations to form many types of stimuli. (See Appendix C for detailed assembly.) The stimuli ranged in complexity from simple panels of various dimensions to real and simulated features of a travel environment.

Simple stimuli consisted of panels or simple targets that were usually presented in near proximity to the participant. The panels comprised five sizes - small (30 cm x 15 cm), medium (60 cm x 30 cm), large (120 cm x 60 cm), giant (120 cm x 120 cm), and long (240 cm x 120 cm).

Environmental features were both artificial and natural, and included a variety of elements and features encountered in typical travel situations. Seven principal artificial features were designed and used - poles, high wall, low wall, interior corner, curved wall, polygon, and alcove. (See Appendix C for detailed measurements and construction. Naturalistic objects and features included trees and bushes, walls and fences, poles and posts, tree branches and awnings, raised curbs and steps, building configurations and other aspects of general layout, fire hydrants, parked vehicles, etc.

Procedure

This study utilized a repeated measures, pre-treatment/post-treatment assessment with no control group.

Standardization

Endeavors were made to control and account for many forms of variation between participants. Among these, age and mental development, and environmental discrepancies were of principal concern.

Most tasks and exercises were designed to be equally applicable to all ages. Although the style of presentation of tasks varied as necessary to accommodate the age of participants, the nature of the tasks themselves was kept fairly constant across all ages for both the assessment instrument and training program. Most tasks were designed to require minimal verbal and problem solving skills, yet were fairly unaffected by more complex cognitive capabilities. The tasks were typically simple and direct, and

required only spontaneous reactions rather than reactions facilitated by advanced thinking or mental discipline. Other age related factors such as level of anxiety in novel situations were handled by thorough procedures of participant preparation and familiarization. These are discussed in later sections.

Tasks and procedures in different environmental conditions were also standardized to some extent. Concerning the assessment instrument, the spatial layouts described in the assessment procedure were roughly matched between environments. Concerning the training program, environments were supplemented with artificial stimuli to increase experiential homogeneity between participants in different environments. Also, efforts were made to adopt similar naturalistic exercises across different environments.

Assessment

An assessment instrument was developed to measure echo performance as applied to two aspects of mobility: straightness of travel, and target location. A set of tasks was administered concerning each aspect. These tasks were administered in random order to each examinee in both pre- and post-assessments.

Straightness of Travel

This set of tasks measured examinees' ability to walk a straight line based on strong echo cues - idle., from parallel walls.

In the strong echo cue task, the examinee was asked to walk a straight line down a straight, Plexiglas passage about 11 m long x 2.6 m wide. (See Appendix C for detailed design specifications.) The walls of the passage were adjusted in height so that the ears of all examinees did not stand above or below the walls' surface. The floor of the passage was hard, not carpeted or padded, and was fully covered by

marked butcher block paper. Each trial began with the examinee centered between the walls, and with feet and nose pointed straight down the center of the passage. The videographer called once to the examinee to "walk straight toward me." The examinee was then asked to walk directly toward the voice without touching the walls. The number of trials administered to each examinee varied to one to three depending on time constraints. All trials were executed consecutively.

The procedure for the straightness of travel task with weak echo cues followed that of the task with strong echo cues but for a few exceptions. Both the butcher block paper and the Plexiglas walls were absent from this task. All echo cues were either very distant, or uneven in nature so that parallel information was weak or absent. In addition the absence of the paper further reduced the clarity of what echo information might have been available. Trials were repeated when examinees departed from the course, or did not finish for whatever reason.

Travel along both runs was timed to the second.

Target Location

This task involved the location of a small target and a large target. The small target consisted of a 120 cm x 30 cm Plexiglas panel affixed vertically to a Plexiglas stand. The large target consisted of the giant, 120 cm x 120 cm target. (See Appendix C for details of design.) Both targets were positioned simultaneously 2.6 m - 3.1 m from the participants, and about 2 M - 3 M apart. Both targets were adjusted so that the ears of all participants did not stand above or below the targets' upper or lower edges. The surfaces of both targets were oriented toward the participants. The participants were first instructed to find one of the targets - whichever they wished. Once this was done, they were instructed to find the other target - whether large or small. Trials were repeated when examinees could not find the targets. All trials were timed to the half second.

Examinee Preparation

Prior to pre- and post-assessments, each examinee was carefully familiarized with the surrounding space. They were familiarized with the layout of the assessment terrain, and were encouraged to examine and explore all pertinent apparatus.

Examinees were permitted to make use of whatever signals or sound cues they wished. No instruction concerning signal use was given before either pre- or post-assessment.

Training Program

The training program utilized a comprehensive and systematic approach to the instruction of echo perception skills, and the integration of echo perception with spatial awareness to enable echo-mobility. The program began by introducing very basic echo perception skills, then proceeded to train more complex skills which demand increasing levels of perceptual processing and perceptual/motor responses.

A detailed layout of the program design is presented in Appendix A.

Stimulus Conditions

Environmental factors. With training indoors, room characteristics and stimulus target placement were configured as much as possible to minimize acoustic interference with echo cues. For example, targets were not placed near walls, doorways, or other nonstimulus objects. Also, targets were rarely placed between a student and a nonstimulus source sound, thus reducing possible nonecho cues to target placement due to sound shadows. Indoor and outdoor noise levels were minimized when possible.

Student preparation. Prior to each task, students were encouraged to examine and explore all stimulus materials and environments.

Stimulus/Response Paradigm

Presentation. Stimulus targets were presented in such a way as to elicit spontaneous responses that distinguished target position (distal and directional), and orientation (straight, and oblique in the horizontal plane). (See Appendix C for a comprehensive description of the stimuli.) The experimenter presented the smaller, less cumbersome targets by standing behind the student, and holding the target with arm extended in the direction desired. Larger, more cumbersome targets were set into place ahead of time, and the student brought into perceptual range of the target. When the target or student was positioned as desired, the experimenter prompted the student to respond - usually to locate or describe the target (see Appendix A.)

When necessary, spatial terminology such as right, left, up, down, near, and far was used in conjunction with tactual cues such as touching corresponding body parts (e.g., shoulder, top of head, waist, etc.), and interaural and distal cues such as

positioning experimenter's voice in space to the right, left, below, etc. Other spatial concepts such as straight ahead were carefully explained verbally and by example when necessary.

Students were given immediate and cordial feedback following all trials. Questions or comments between stimulus presentations were permitted and addressed, and were encouraged between lessons and trials. Students were encouraged or instructed if necessary to move their heads for purposes of auditory scanning. Three principal types of responses were elicited - head/trunk orientation, locomotor, and verbal.

When exercises involved the use of head/trunk orientation, the student was instructed to turn his body toward or away from the stimulus target. Preliminary observations were made to determine which students oriented their heads, and which oriented their trunks more accurately. Then, scoring was based on the method of orientation. Targets were positioned such that their primary surface faced the student's head.

When locomotor responses were needed, students were instructed to walk toward or along side a stimulus target, or to avoid a target as an obstacle. At times students were also instructed to stop walking in a certain relationship to the target (e.g., when reaching the end or beginning of a wall).

When verbal skills permitted students were instructed to state certain relationships between them and stimulus targets (e.g., centered or not centered between two objects, nearer to this object or further from that one, etc.) Students were also asked to describe and identify objects based on echo qualities.

Controls. Possible light cues were controlled by using highly transparent or color camouflaged stimuli whenever feasible. Blindfolds were used only for visual assessment purposes, or when lessons involved naturalistic (nontransparent) stimuli. Even so, the use of blindfolds was rare.

Tactile and auditory cues such as air pressure, experimenter movement when contacting student, and

ground surface characteristics were controlled in a variety of ways. For example, targets were not placed so that students could use cracks in the sidewalk to find them. When the experimenter moved targets with arm extended, he moved both the arm holding the target as well as his free arm so that students could not use arm movement (either audible or tactile) to follow the target. When wind was present, the targets were usually presented down wind, and, since the targets were usually transparent, the warmth from the sun was never blocked.

Olfactory cues such as target odors were controlled by using mostly targets that were made of odor-free plastic.

Optimizing Stimulus Response

Stimulus intensification. In some lessons, particularly where relatively new or advanced skills were being instructed, a low intensity signal was paired with the echo stimulus in the initial stages of

training in that skill. The sound emanated from one of three locations: the echo stimulus by experimenter tapping on the stimulus, behind the stimulus such that the stimulus shadowed the sound, or opposite the stimulus from vocalizations produced by either student or experimenter. The sound shadow produced by placing a target between the student and a source sound such as traffic called subtle but perceptible attention to the presence or absence of the stimulus. Vocalized sounds aimed toward targets included aspirant V, Z, and shsh sounds. The targets were sometimes moved about rapidly in order to draw attention to changes in the sound field by abrupt distinction. In general, the signals used for stimulus intensification were decreased in volume until only the echo cues remained. Exceptions included deliberately produced tongue clicks, and incidental sounds such as footsteps and cane taps.

Stimulus manipulation. In some cases it was necessary to manipulate the stimulus targets in order

to heighten echo sensations. Simpler, less difficult stimuli began some preparations for more advanced skills. When these simpler stimuli were mastered, instruction progressed to more difficult stimuli. For instance, in preparation for learning to center between two objects, the giant panels were used initially at close range, then moved to greater distances, and finally replaced by the large panels at increasing distances.

Program Presentation

General program format. The program consisted of several sessions that were administered once or twice a week over a span of 11 to 17 weeks depending on student schedule requirements. The program sessions consisted of three types: preliminary, training, and assessment.

In the preliminary session the experimenter became acquainted with each student, and with all involved parties including parents and teachers when

possible. An endeavor was made to promote a sense of trust, comfort, and mutual respect between each student and the experimenter. Though the experimenter was introduced by name to all participants, he was introduced as a "teacher" to the younger children, and a "teacher/student" relationship was emphasized. The time was largely spent explaining to the students and all interested parties what the project was all about. The seashells and fish bowls were introduced to assess the students' level of comprehension. The "ocean in the seashell" phenomenon was demonstrated, and it was shown that a small seashell sounds different from a large seashell - that the difference between them can be readily determined by listening. Each small and large seashell was presented one at a time near the left and right ear, then to both ears simultaneously - small on one side and large on the other. It was then demonstrated that a similar effect occurs with a fish bowl. Finally, it was demonstrated that the motion of a hard, flat surface moved toward and away from the face can be easily sensed while orally producing a "shsh" sound. The experimenter

demonstrated this himself, then asked the students to do so. When students had difficulty performing the task, the experimenter produced the "shsh" noise over the student's shoulder, and moved the surface toward and away from the student's face. Student feedback was elicited throughout these demonstrations. About 15 minutes was allotted for this session.

The training sessions began three to four weeks after the preliminary session, and consisted of a series of lessons designed to train echo-mobility systematically. The training portion of the program spanned eight to 12 weeks, and consisted of about 40 lessons. This time was divided according to students' schedules and attention span. In general, students younger than nine years old were seen twice a week for about 25 minutes, while older students were seen once weekly for about 45 minutes. The group of participants who were pre-assessed only received 170 to 545 minutes of training with an average of about 324 minutes. Students who were post-assessed received 270 to 500 minutes - averaging about 357 minutes. Breaks and diversions during the training sessions

were permitted when necessary, and were not counted as part of lesson time. There was a two week break for all but four of those pre-assessed only, and all but two of the post-assessed students due to experimenter absence. In addition, five of those pre-assessed only and four of the post-assessed students missed one other week due to a holiday. Further absences seemed to be scattered more or less randomly among all students.

The two assessment sessions bracketed the series of training sessions, and were designed to evaluate the effectiveness of the program by measuring echo-mobility skill before and after training. It was never spoken of as a "test" of student performance, but rather an evaluation of program effectiveness. The assessment sessions took approximately 20 minutes per examinee.

Progression of lessons. The lessons were administered in a variable sequence which covered specific skills concerning awareness through echo

perception of location, density, and orientation of objects and land mark features in the surrounding environment - both in and out of doors. Generally, the level of challenge progressed from static to dynamic perceptions of object characteristics, and through tasks involving increasingly complex stimuli. Dynamic lessons in mobility were interspersed throughout the program among the static lessons, and were intended to apply and refine skills learned in static conditions. The program began with extremely basic skills such as the perception of the location of the giant panel - progressing to more complex skills such as tracking an object as it moved through near space, and locomotor skills such as maintaining an awareness of one's orientation to several objects while walking, and identifying objects by echoes.

Lesson format. The length of each lesson was highly variable - taking anywhere from five to 30 minutes depending on the complexity of the lesson and the skill or level of cooperation of the student.

Each lesson was designed to develop or enhance a specific echo skill or combination of skills that were relevant to mobility. Each training session began with a review of previous training sessions, and each lesson built upon the skills introduced previously. Each lesson consisted of two principal components - guided preparation and evaluation.

During guided preparation, verbal instruction varying in tone, vocabulary, and sophistication appropriate to age was used to introduce the nature of the lesson and its practical application. This was paired with stimulus presentation and feedback to clarify sensory experience and to hone judgements. Sensory experiences were discussed, explained, and clarified where necessary and feasible. Students were generally shown all materials to be used in each lesson, and were told very specifically what they were to do, and why. Where relevant, each lesson was discussed in the context of previous lessons, and the practical application of each was explained and discussed. Trials were administered in a relaxed, informal manner until the student seemed to get the

hang of the skill taught in that lesson. Students who exhibited immediate grasp of the skill moved directly to the examination portion of that lesson. Others took longer.

After the student seemed properly prepared, a brief evaluation of comprehension was administered. This was a random trial series based on those covered in the preparation phase. It was administered with feedback, and was appended to the preparation phase such that only the experimenter knew of the examination portion. The term "examination" was never used. About half a dozen trials were administered, depending on the nature of the lesson. Blank or check trials were never used. Seventy-five percent success was used as a minimum indicator of comprehension. If the examination was not passed, the experimenter typically went on to another lesson, and returned later to the one not grasped to execute the same procedure as before. No mention of "failure" was ever made. Thus, each student progressed at an individual rate without undue pressure.

Lesson prioritizing. All of the lessons were specifically relevant to orientation and mobility, but they varied somewhat in terms of the degree to which they applied to the echo-mobility assessment instrument used to evaluate this program. Therefore, the lessons were prioritized according to their degree of applicability to that instrument. Those lessons that were most applicable were given first priority; those least applicable were given last priority. Though all students followed the same basic progression of lesson difficulty, students who progressed especially quickly were given extra lessons that had less bearing on the assessment per sé. In this way the minimal skills needed to negotiate the echo-mobility assessment were taught to all students, but additional lessons were available in an integrated sequence to more advanced students. Although these extra lessons were embedded in the sequence of the overall lesson plan, they were, with discretion, administered out of sequence when necessary.

Handling variability. There were many extraneous variables that necessitated modifications to minimize their effects, and some that could not be fully controlled. All deviations were carefully noted.

Concerning environment, different training environments afforded different characteristics and conditions. One school, for example, possessed indoor hallways that were used for some exercises, while other schools afforded only outdoor environments. Another school had only wrought iron rather than chain link fences. Exercises varied somewhat between students in different environments, but the use of an assortment of artificial targets enabled the standardization of many experiences.

Students varied widely in their level of echo ability and mobility skill in the beginning of the program, as well as their rate and pattern of echo learning through the course of training. It was necessary to tailor certain lessons or sequences of lessons to individuals, and to design new lessons to accommodate certain student characteristics (e.g.,

extreme advancement, good use of residual vision, etc.).

Sound Generation

For purposes of this experiment, attention was focussed on interpreting and utilizing self-elicited echo information. Students were, therefore, encouraged to execute tongue clicks in a deliberate yet discrete manner. It was found difficult to teach a given type of tongue click, so no specific attention was given to type of click as long as it was not obtrusive. Tongue depressors dipped in fruit jelly were useful and necessary in teaching a few students how to click. All sorts of clicks were used. Hand claps and cane taps were also used on occasion where circumstances warranted. Students were taught to vary the intensity of their echo signals throughout the course of training as environmental circumstances required, and to keep their signals discrete and functional. For example, students that clicked very rapidly were instructed to slow down so that the

information elicited by each click could be fully processed. In addition, students were taught to combine their clicks with other echo-mobility techniques such as auditory scanning and interpretation of echoes from incidental noises.

Data Collection

The Assessment

All trials in both tasks were videotaped from a distance of about 50 feet. Video emphasis was placed on examinees' lower body so that course of travel could be observed.

In the strong echo cue condition for straightness of travel, the course was divided lengthwise into five regions by dark lines. The course was then further divided conceptually into five additional regions when the video data were coded - resulting in a total of ten regions.

In the weak echo cue condition, no physical lines were available. The course was conceptually divided

lengthwise into five regions when the video data were coded.

The conceptual divisions and data coding were executed by someone who was unaware of which assessments were pre- or post-treatment. Each examinee's first-moved foot was tracked step by step according to which region that foot landed in at each step. Only the first completed trial under each condition was coded for each examinee.

For the target location task the first trial of each set was used. The pre-treatment and post-treatment conditions were randomized for each examinee within each stimulus condition, and shown in pairs to a panel of five judges. The judges had no prior knowledge of or connection with this study, and had little or no prior experience with blind people. They were asked to rate on a dichotomous scale which one of two attempts to find a given target showed the greater awareness of the target's location on the part of the examinee. About 15 minutes was used to train the judges to conceptualize awareness in terms of grace and confidence. Thus, gracefulness and

confidence were assumed to reflect awareness. Several video examples were shown to demonstrate all points, and any procedural questions were answered. Judges practiced rating two examples before beginning with the actual examinees. Each pair of attempts was shown once, and judges were given about five seconds to decide.

The Training Program

Meticulous notes were recorded to audio tape concerning many aspects of programmed instruction for every participant. Qualitative observations and quantitative data were recorded concerning level and style of performance related to age, degree of vision, general orientation and mobility skill, and, in the case of one participant, mild hearing impairment.

RESULTS

Hypothesis Testing

Straightness of Travel

Straightness of travel was measured by determining the extent of overall veer from a center line. The course was divided into five intervals that were each 45 cm wide. The intervals were coded as 2 through -2 in both echo courses with 0 representing the center interval. Veer measurements were taken to the nearest half interval for the strong echo course and to the nearest interval for the weak echo course. Contacts with the boarder in either course were assigned an additional value of one unit of measure. Thus, with the inclusion of boarder contact, the echo courses were assigned a total spread of ± 2.5 on the strong echo cue course and ± 3 on the weak echo cue course. Using these regions of deviation, values

representing the extent of veer were computed for each participant by taking the square root of the mean of the squared veer from the center line. These values are simply referred to as deviations or RMS scores. Some of these values were then adjusted by a percentage multiplication to account for discrepancies in comparative course width. For example, 12 of the total number of participants were pre-assessed under conditions in which the weak echo course was 25 percent wider than the corresponding strong echo course. The deviation values from the weak echo condition were therefore multiplied by 1.25 to adjust for this difference.

To test the hypothesis that straightness of travel guided by echoes would improve as a result of this program, examinations were conducted to determine both the extent of improvement in straightness of travel where strong echo cues were present, and the extent to which straightness of course was actually attributable to the perception of strong echo cues.

As can be seen in Figure 1, the distribution of scores for raw improvement under the strong echo cue

condition for both pre- and post-assessment is sufficiently normal to warrant the use of a parametric test statistic. Therefore, a parametric correlated t-test was used to compare performance in the strong echo course between pre- and post-assessments, $t(11) = 1.96$, $p < .076$ (two tailed), $d = .56$..

Table 2 shows comparisons of deviation scores between the pre-assessment and post-assessment in the strong echo cue condition. Figures 2-13 shows plotted comparisons of participants' travel between pre-assessment and post-assessment.

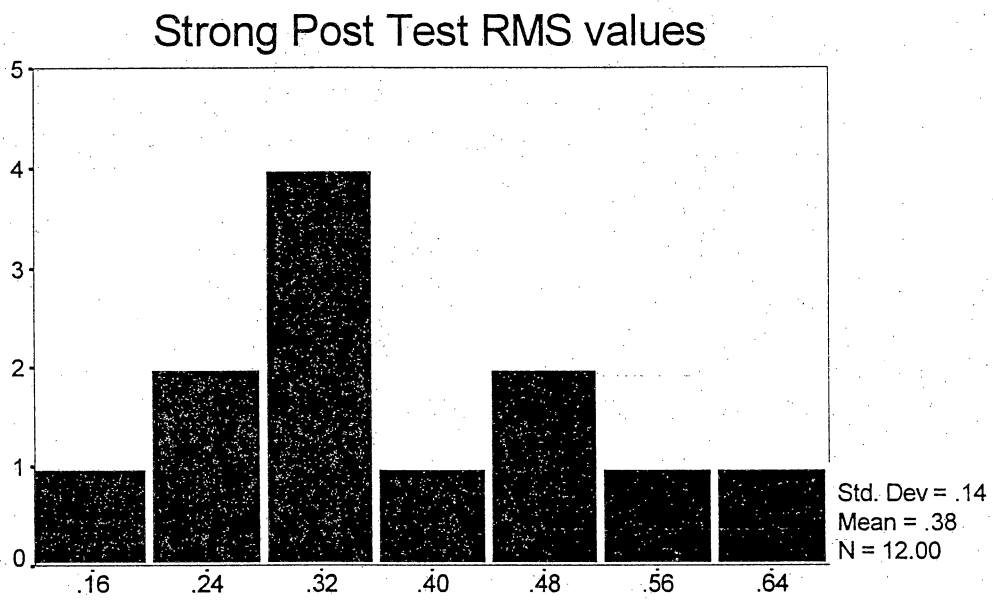
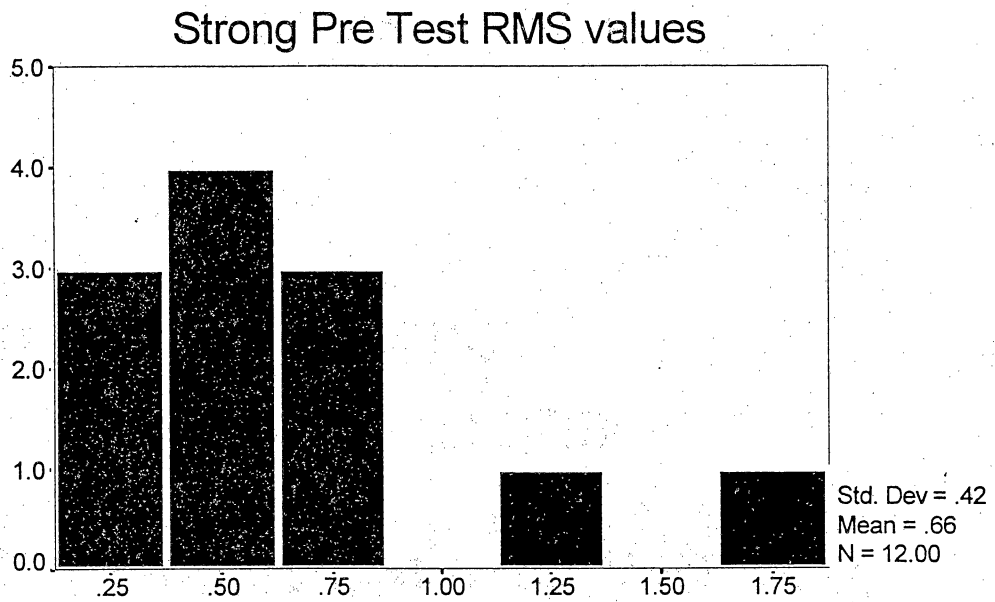

Figure 1. Distribution of Pre-Assessment and Post Assessment RMS scores for students in the strong echo cue condition

Table 2

RMS Deviation scores for both
Pre-Assessment and
Post-Assessment in the strong
echo cue condition.

	Pre-Assess ment	Post-Assess ment
1	.65	.37
2	.59	.19
3	1.67	.35
4	.29	.66
5	.84	.26
6	.31	.34
7	1.27	.29
8	.26	.53
9	.48	.24
10	.71	.29
11	.44	.52
12	.43	.50

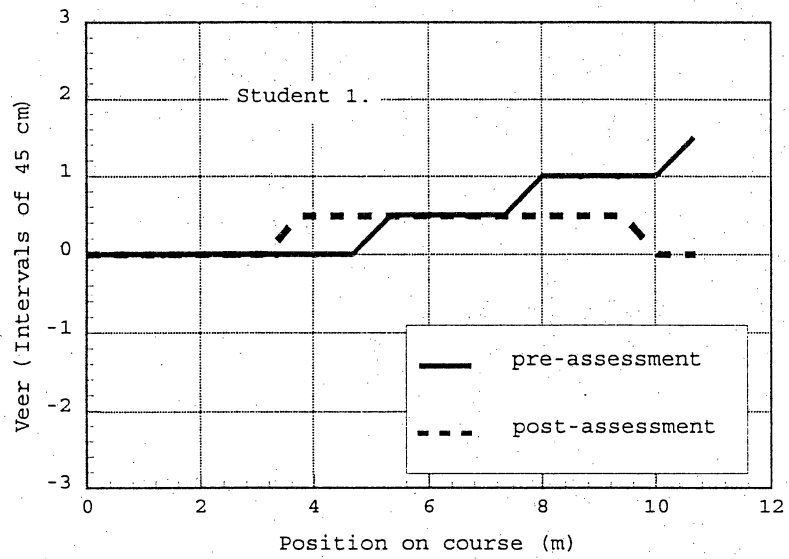

Figure 2. Deviation from center of course in strong echo cue condition for student 1.

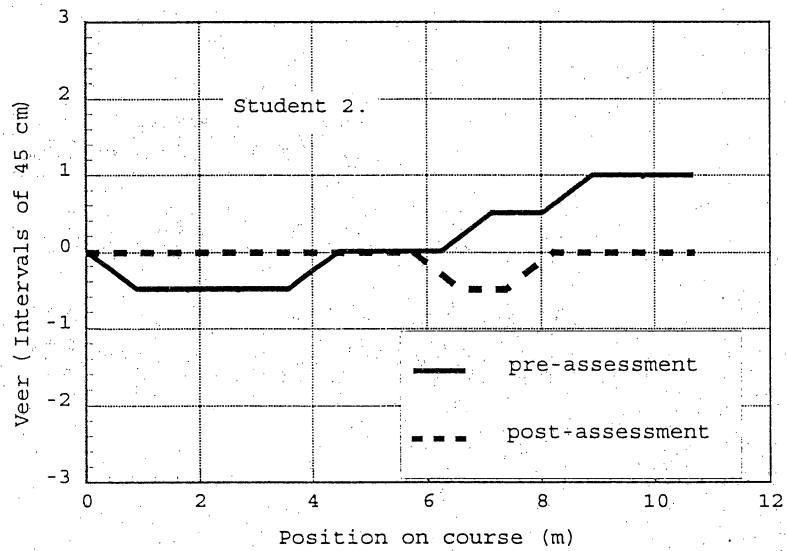

Figure 3. Deviation from center of course in strong echo cue condition for student 2.

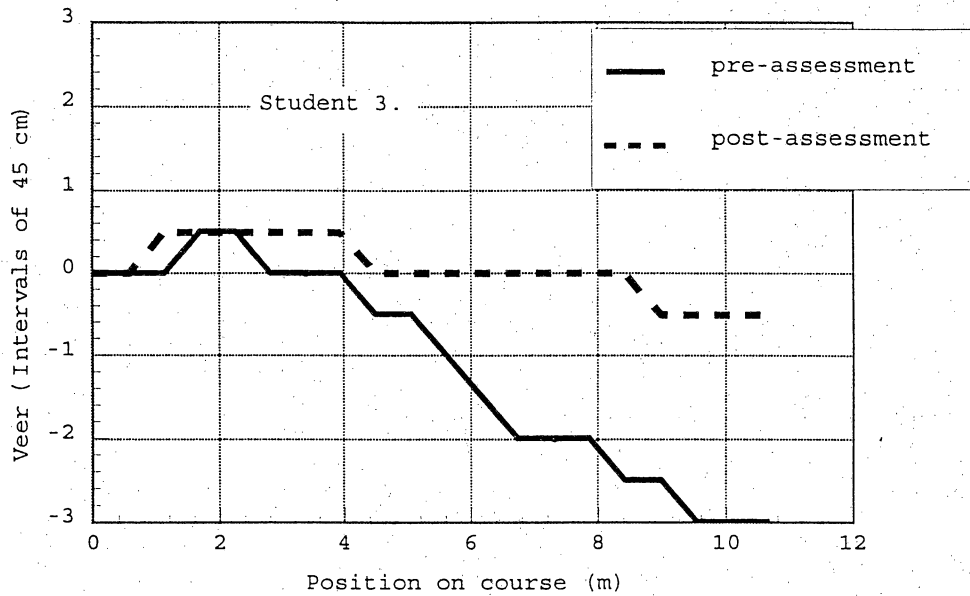

Figure 4. Deviation from center of course in strong echo cue condition for student 3.

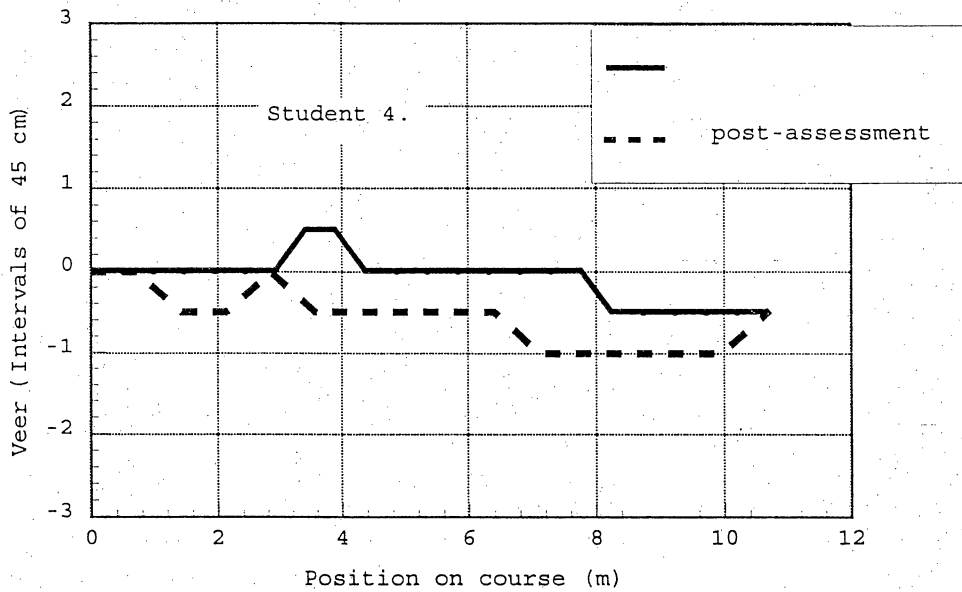

Figure 5. Deviation from center of course in strong echo cue condition for student 4.

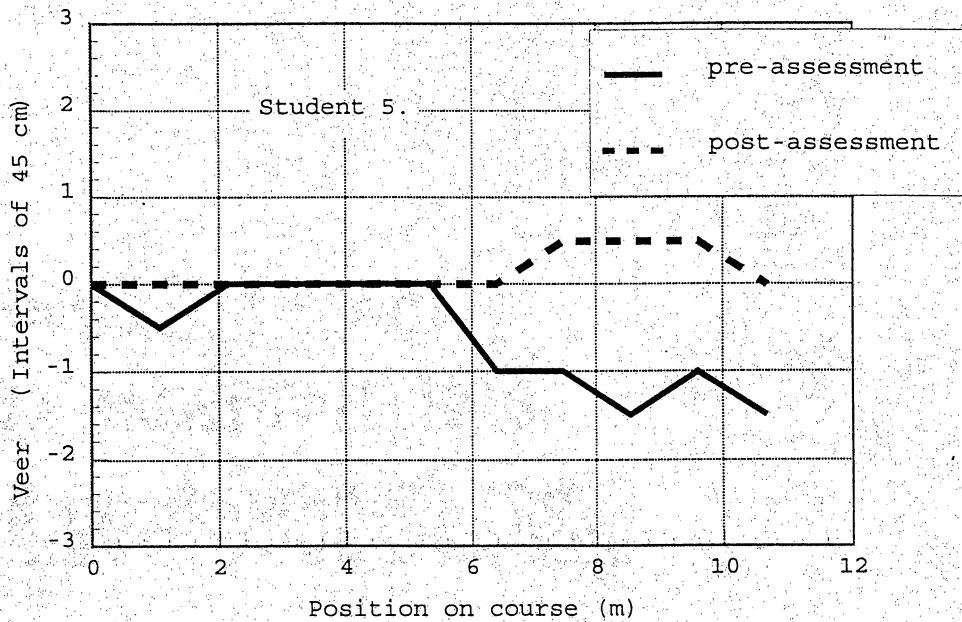

Figure 6. Deviation from center of course in strong echo cue condition for student 5.

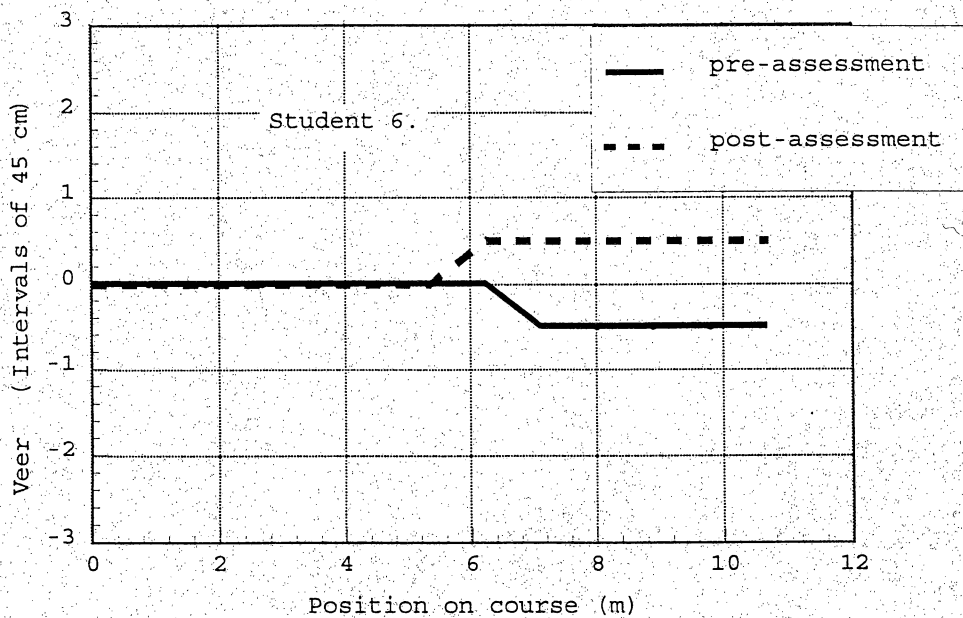

Figure 7. Deviation from center of course in strong echo cue condition for student 6.

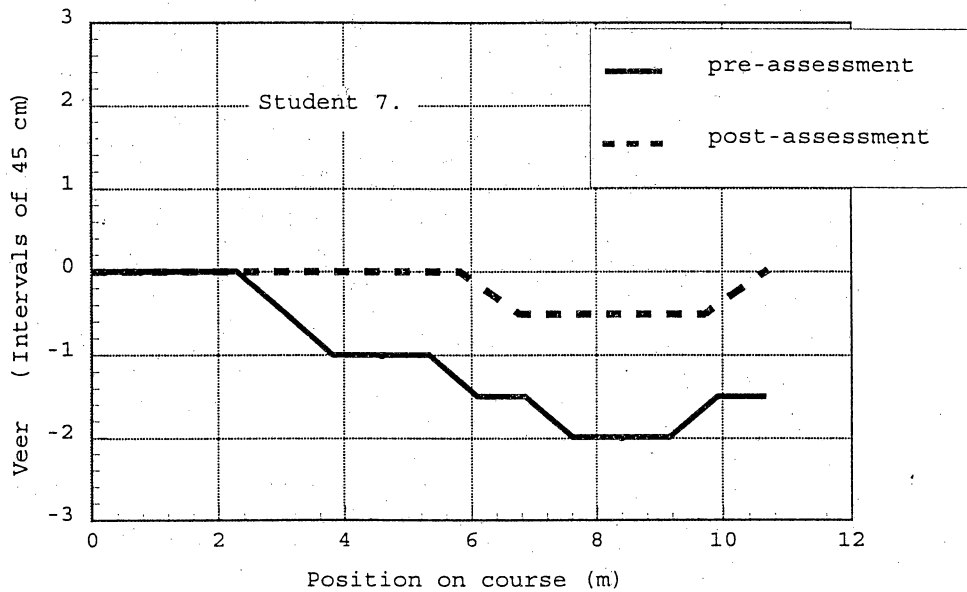

Figure 8. Deviation from center of course in strong echo cue condition for student 7.

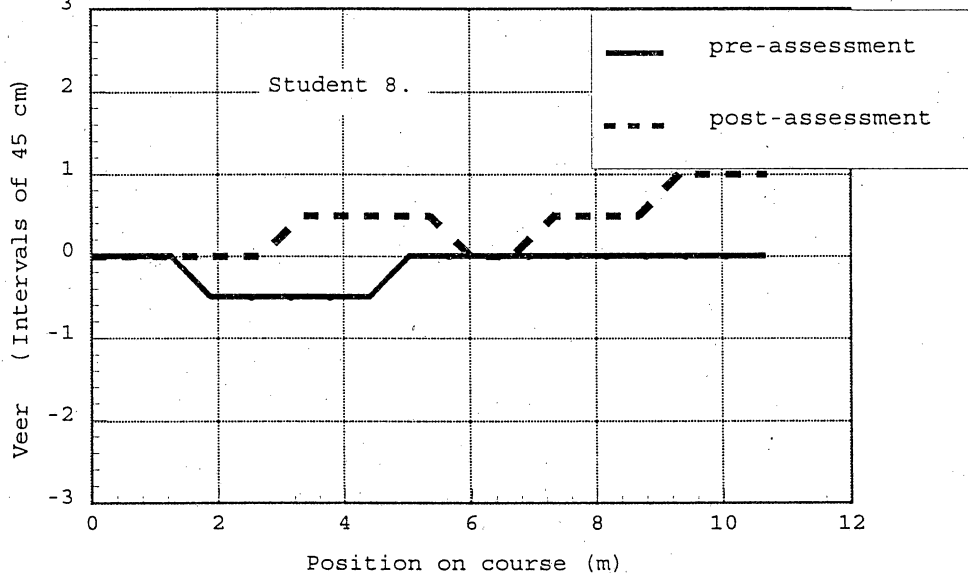

Figure 9. Deviation from center of course in strong echo cue condition for student 8.

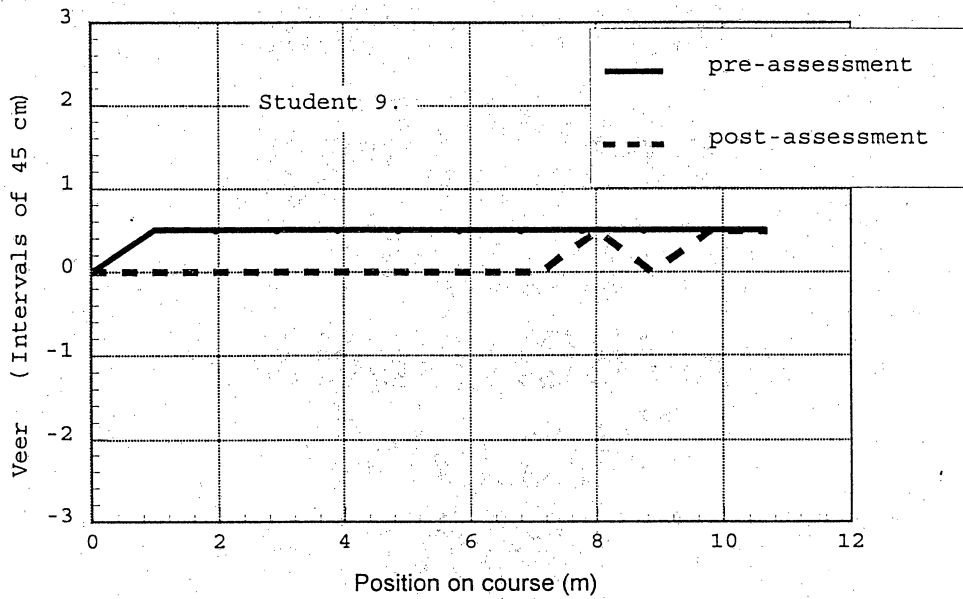

Figure 10.. Deviation from center of course in strong echo cue condition for student 9.

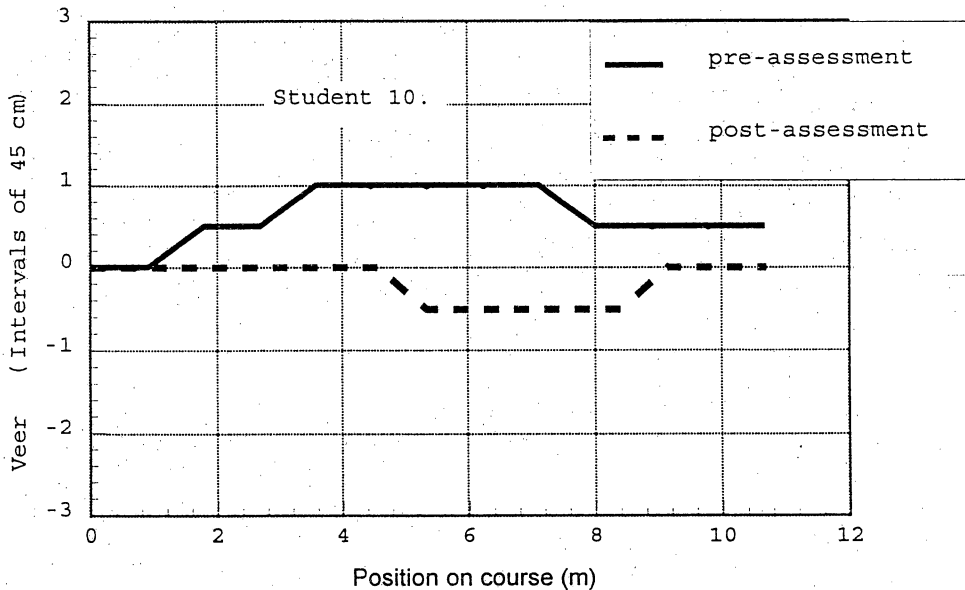

Figure 11. Deviation from center of course in strong echo cue condition for student 10.

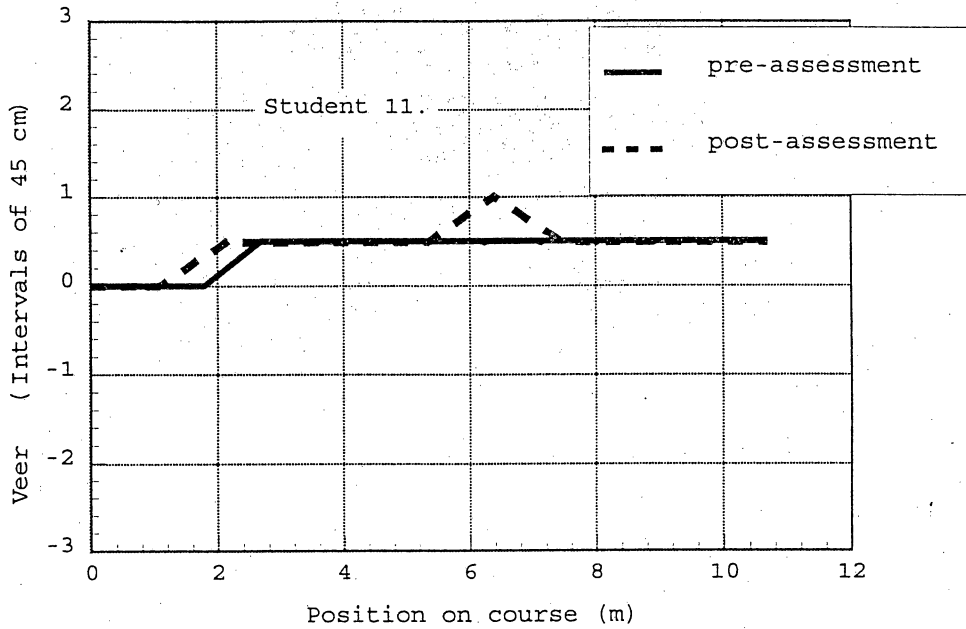

Figure 12. Deviation from center of course in strong echo cue condition for student 11.

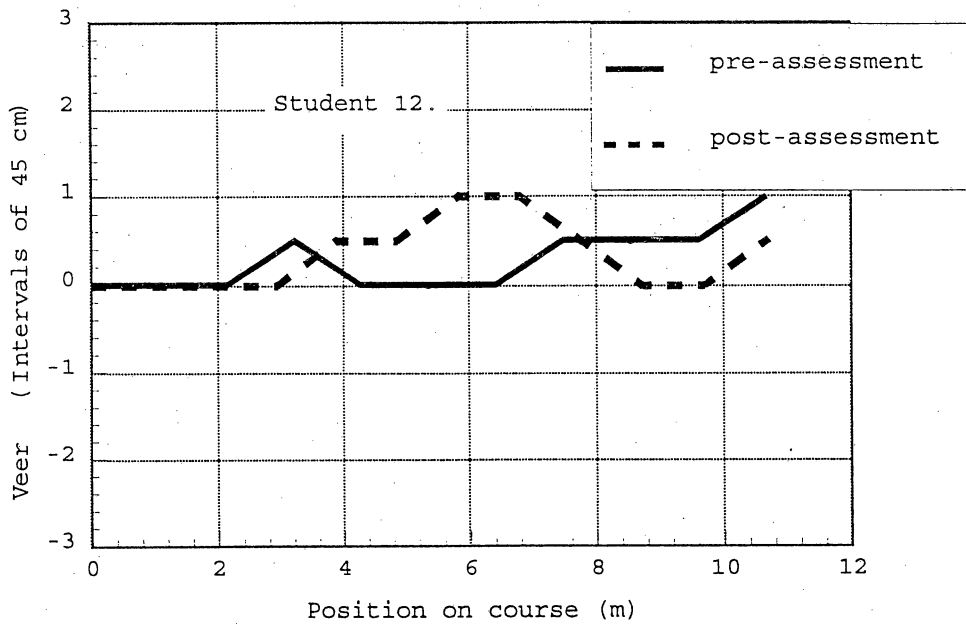

Figure 13. Deviation from center of course in strong echo cue condition for student 12.

To ascertain the extent to which improvements might be attributable to the use of echoes, two factors were examined. Nonparametric test statistics were used in these examinations, because the distribution of scores from the weak echo condition was bimodal as can be seen in Figure 14.

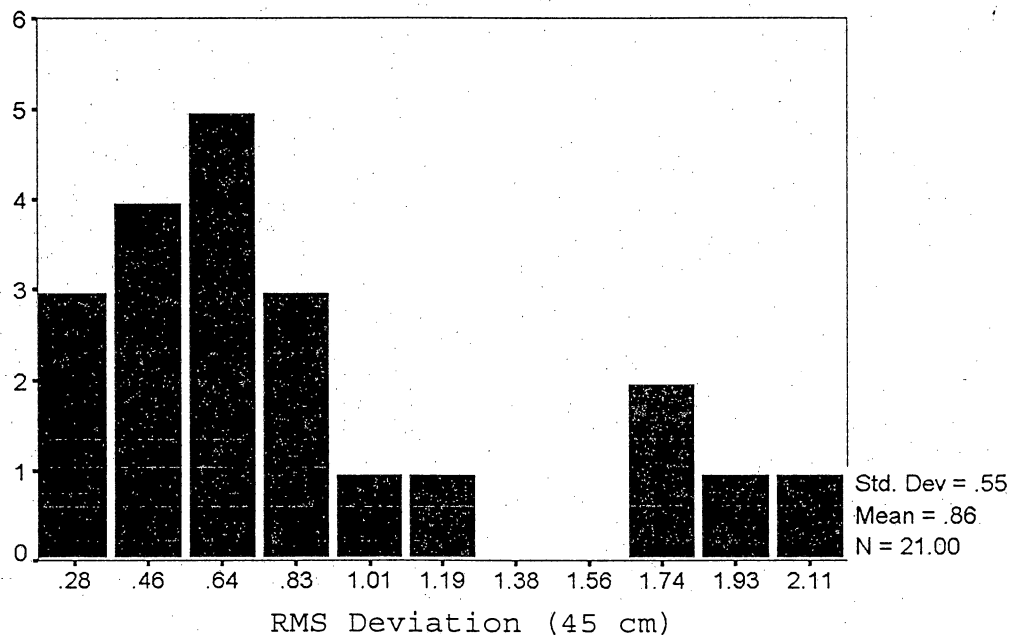

Figure 14. Distribution of Pre-Assessment RMS Deviation Scores for the Weak Echo Cue Condition.

The first examination concerned the extent to which straightness of travel can be fundamentally attributed to the presence of strong echo cues. A

Wilcoxon correlated T-test was used to compare straightness of travel in the pre-assessment between strong and weak echo courses, $T(20) = -2.28$, $p < .023$. A total of 21 out of 23 participants was included in this comparison. Two of the 23 participants were excluded because it became clear through training that they possessed enough residual contrast perception to be capable of detecting the grass borders of the weak echo course. In addition it was determined that a mild hearing loss in one of these participants negatively affected his echo perception abilities.

Table 3 shows comparisons between the sets of deviation scores between the strong and weak echo courses for the pre-assessment.

Next, an examination was conducted to determine the extent to which improvement in straight travel with strong echo cues can be attributed to increased ability to utilizing these cues. A Wilcoxon correlated T-test was used to compare pre-assessment to post-assessment performance in the weak echo course in a sample of seven out of the original 12,

Table 3.

RMS Deviation Scores for 21
students in the Pre-Assessment
Test for both Weak and Strong
Echo Cue Conditions.

<u>Strong</u>	<u>Weak</u>
.65	1.05
.59	.60
1.67	.78
.29	2.71
.31	.83
1.27	1.06
.26	.53
.48	2.11
.71	.28
.44	.6
.43	.89
.63	.35
.33	.57
.57	.6
1.04	.61
.25	2.14
.26	.412
.00	.84
.50	1.40
.45	.96
1.13	2.31

$T(6) = -1.52, p < .13$ (two tailed). One participant was excluded due to his apparent capacity to perceive the grass boarder of the weak echo course visually. Four others were excluded because the post-assessment was conducted under conditions in which echo cues were substantially weaker than in the pre-assessment; this rendered performance comparisons impossible.

A Wilcoxon T was then computed for a random sample to compare pre-assessment to post-assessment performance, $T(7) = -1.86, p < .063$ (two tailed).

Target Location

One participant was excluded from these analyses because he could apparently see the person used to hold up one of the targets when its transparent stand broke. This left a sample of 11 for the large target. An additional participant was excluded from the small target sample, because he was not able to find the small target in either assessment. This left a sample of 10 for the small target.

The ratings from each judge were coded according to whether the pre-assessment or post-assessment was chosen as demonstrating greater awareness, and a binomial probability coefficient was computed. The results for the large and small target were $p < .21$ and $p < .55$, respectively.

Simple inter-rater reliabilities were then computed for each condition by computing Pearson's r 's between each pair of judges for each condition, and taking the average and range of these correlations. These results are shown in Table 4.

Table 4

Means and Ranges of Inter-rater Correlations for Large and Small Targets.

	Large target	Small target
Range =	.69	.79
Mean =	.62	.42

A correlation coefficient was then computed between the correlation coefficients for large and small target ratings, $r = .14..$

Table 5 shows the judges' ratings for each participant in each condition.

Table 5

Ratings by 5 Judges of Target Location for
Students Finding the Large and Small
Targets.

Student	Judges									
	Large					Small				
	a	b	c	d	e	a	b	c	d	e
1	1	1	1	1	1	2	2	2	2	2
2	1	2	1	2	2	2	2	2	2	1
3	2	2	2	2	2	2	2	1	2	1
4	1	2	2	1	2	1	1	1	1	1
5	2	2	2	2	2	0	2	2	2	2
6	1	1	1	1	1	0	0	0	0	0
7	2	1	1	1	1	2	1	2	2	2
8	2	2	2	2	2	2	1	1	1	1
9	1	2	1	2	2	1	1	0	1	2
10	1	1	1	1	1	2	1	2	2	1
11	2	2	2	2	2	1	1	1	1	1

Note. A score of 1 corresponds to the judge (a,b,c,d,or e) choosing the pre-assessment trial as the most aware. A score of 2 correspond to choosing the post-assessment trial. Zeros indicate that no score was given.

Explorative Statistics

No further analyses were run concerning the target location tasks. However, several statistics were computed concerning the straightness of travel variable under the strong echo condition. In seven of the pre-assessment only sample, scores from two trials through the strong echo course were available. A correlated t value was computed comparing performance on these trials ($t(6) = 1.09, p < .32$) and a second t value was computed between performance on pre- and post-assessment for a random sample of seven from the 12 participants that were both pre-assessed and post-assessed ($t(7) = 2.35, p < .057$).

A final statistic was computed correlating the difference scores between deviation values for pre- and post-assessment performance in the strong echo condition with the amount of training each participant received in minutes, $r = .52, p < .086$.

Figure 15 shows a scatter plot of deviation difference scores to amount of training received.

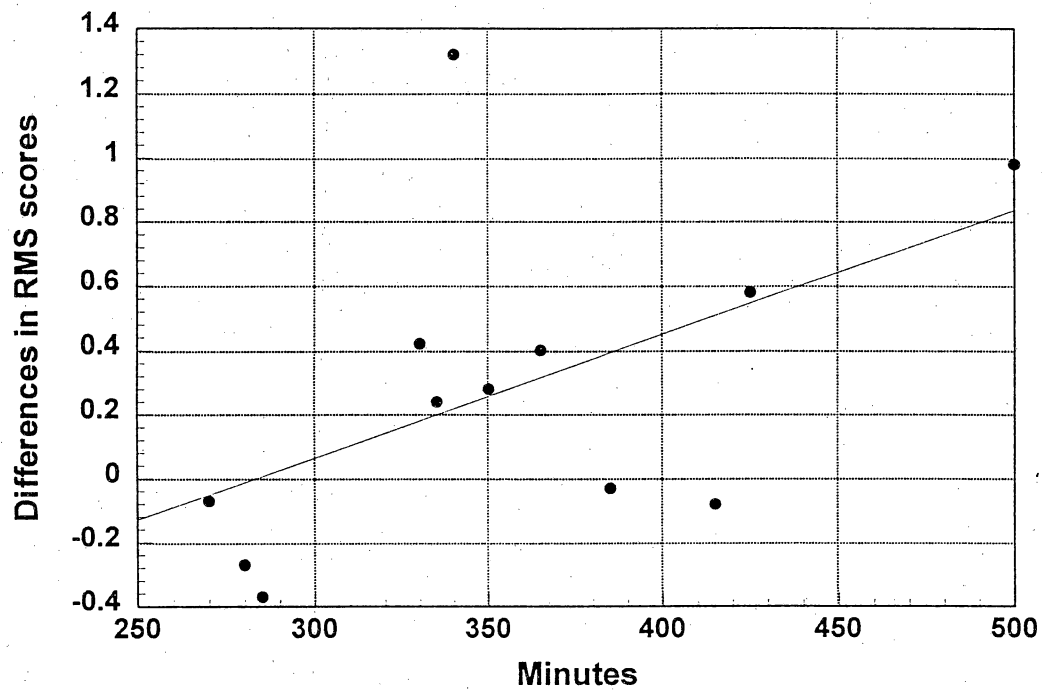

Figure 15. Plot of the change in the RMS scores of 12 students as a function of lesson time spent with

DISCUSSION

The results of this study suggest marginal improvement in straightness of travel. Furthermore, it seems likely that any improvements can be attributable to enhanced echo skill rather than other factors. There seems to be a mild correlation between time spent in training and degree of improvement, but a larger sample is needed for further clarification. No improvement in target location was demonstrated. It is this author's opinion that the marginal nature of these results are attributable primarily to issues concerning the design and implementation of the assessment instrument.

Issues in Assessment

The first issue concerns apparent deficits in the sensitivity of the instrument to measure actual improvement in levels of echo skill. The skills assessed were too few and too narrowly focussed to provide an accurate representation of actual ability -

whether raw or improved. Only two skills were tested rather than a constellation of skills which might have better represented true ability.

The assessment instrument actually employed was truncated from the instrument originally proposed due to last minute technical constraints on space and time. Straightness of travel was assessed more or less as planned, but the target finding task was originally intended to provide a variety of measures concerning participant awareness of target location.

The targets were originally to be moved to locations that varied randomly according to predetermined distal and lateral positions relative to each participant. Discrete methods were originally proposed to measure time to find the target, extent of wander in approaching the target, and successes in actually locating each target. Due to unfortunate circumstances these measures could not be taken, and an interrater design had to be applied. To make matters worse, raters reported that much of the video footage was simply too poor to allow rendering of anything better than sheer guesses on many of the

trials. Different videographers had been used between participants and between assessments--each with his or her own style of shooting. In some cases only the participants' legs or feet could be seen, or the picture was blurred, or the video did not contain the first few seconds of a given trial. In most cases the transparent targets themselves could not be seen in the video. Due to the low reliability of judges, it is impossible to determine quantitatively whether the apparent lack of improvement on this task is attributable to a low effect, or data that simply can't be measured. It is this author's opinion that differences occurring between pre- and post-assessment were subtle, and would be difficult to discern under the best of circumstances.

The tasks chosen to assess skill levels were also too easy - resulting in something close to a ceiling effect. Many of the participants demonstrated much more highly developed skills in the pre-assessment than anticipated - leaving little room for improvement. In the pre-assessment, the travel of many of the participants down the strong echo cue

course was almost perfectly straight. The treatment effect size was driven downward by participants whose straightness of travel remained similar over training due to the high magnitude of their initial performance. In essence, most of those participants who did not walk especially straight in the pre-assessment improved markedly in the post-assessment, while those who walked very straight in the pre-assessment continued to walk very straight when post-assessed. Based on informal comparisons of the pre-assessment/post-assessment video data, it is this author's impression that, had the resolution of data been finer (e.g., 2.5 cm instead of 22.5 cm intervals), improvements in levels of performance may have shown more clearly for some of the participants. Being that there were no solid criteria for exclusion, all participants were included whatever their level of skill.

Most participants did well finding the targets as well - especially the large target. Nearly every participant was able to locate the large target easily in the pre-assessment. Whatever improvements that may

have occurred were probably subtle, and thus invisible to the judges under the conditions of poor video footage. In addition, there were subtle kinesthetic and tactile cues that some participants might have been able to use to assist them to find the targets on some occasions. For example, since time and space restrictions did not permit random relocation of targets, the targets remained stationary while participants were relocated. It is this experimenter's experience that blind people, even young children, can be very difficult to disorient in confined spaces by such means as spinning them around or guiding them along sequitious routes. It has been shown that children as young as two-and-a-half years can map enclosed spaces without the apparent use of echoes (Landau, Gleitman, & Spelke, 1981; Landau, Spelke, & Gleitman, 1984).

The second issue related to the inadequacy of the assessment instrument concerns a lack of robustness to systematic or random errors in performance. Few trials were taken in any given condition, and only the first usable trial in each condition for each

participant was coded for analysis. Inadvertent errors in performance can happen at any time for any reason, and the design of the current assessment instrument assumed that random distribution of errors across all conditions for all participants would not impair improvement measures. However, with so few trials per condition, the occurrence of single errors, random or systematic, called into question the effectiveness of treatment for any given participant. One participant, for example, performed very well on his pre-assessment and maintained a very high level of performance throughout training. However, he just happened to make a severe mistake on one of the post-assessment tasks. Such mistakes were not at all characteristic of this participant, but his scores show a distinct negative effect nonetheless.

To complicate matters further, performance errors do not appear to be distributed randomly, but seem to have been introduced systematically into the post-assessment condition. The pre-assessment took place during the school year, while the post-assessment occurred toward the end of summer

school. During summer school, instructional emphasis shifted from academic performance to recreational activities. For four of the participants, for example, an outdoor assembly demonstrating fire fighting methods was held about one hundred meters from the test site. Trials often had to be cut short and restarted due to the intense blaring of sirens, horns, fire engines, and excited crowds of hundreds of children. In addition, during summer school, all of the participants received less than half of the normal mobility training beyond the training provided in this study that they received during the school year. This comparative deficit in training resulted from an unavailability of their mobility instructor. To say the least, conditions surrounding the administration of the post-assessment were less than ideal. The participants seemed less thoughtful and disciplined during summer school than during the regular school year. Their minds were not on performance.

Shingledecker (1983) demonstrated that a high degree of mental effort is required for successful blind mobility. This notion is born out by the

experiences of many blind people. It seems reasonable to suppose, therefore, that blind mobility performance may be vulnerable to frame of mind - especially in children. If the attentional requirements of blind mobility are high as seems likely, then any diversion of attentional resources will negatively affect performance. For example, if the participants were anxiously waiting to return to an art project, or were looking forward to a recreational outing planned for later on that day, performance both in the training as well as the assessment sessions seemed diminished.

In this study, the assessment instrument was not robust to errors resulting from attentional diversion or other causes. If multiple trials had been available for all participants under each condition, and the best of them used for analysis or even an average, this drawback might have been ameliorated.

General Observations

While a thorough exposé of observations, impressions, and accumulated information from this

program is presented in Appendix D, there are a number of points that bare discussion here.

Every one of the participants already possessed basic echo skills. If improvements were to take place, they would likely have been found at advanced levels not measured by the current procedure. For nearly every participant on nearly every training exercise, notable short term improvements were demonstrated over the course of a given session. Such improvements were immediately apparent to anyone observing. In a centering exercise, for example, the participants would typically place themselves somewhat off center on the first try. When told that they were a little off center, they would almost invariably correct themselves immediately. By several subsequent trials, the participant was typically able to center himself with great precision. The trick was to sustain notable improvement over time. The pattern typically took the form of participants improving markedly on a given task at a given time. Then, when tested on a later session, they had regressed to a level somewhere between there original performance and

their previous level of improvement. They would then regain their level of skill quickly with a few more trials of practice. Thus, it was not generally difficult to teach many of the skills to most of the participants, but it was difficult to facilitate the long term refinement and maintenance of given skills in the time available. It is evident that, though the most basic echo skills may be taught in minutes, advanced skills take much time and practice to learn and maintain. This is consistent with the acquisition of other mobility skills such as effective cane technique or crossing major intersections. While a more thorough and sensitive assessment instrument would probably have yielded more positive results, it seems probable that sustained, marked improvements will take much time and practice.

The fact that participants showed marginal improvement on straightness of travel over target finding is of particular interest, because very little time was actually spent training straight travel. Most of the participants were so good at straight travel that it seemed worth devoting attention to a

multitude of other skills. It may be that participants' listening skills were becoming tuned in a general way - enabling them to recognize subtler nuances of factors already familiar to them.

Alternative Procedures

A great deal was learned over the course of this study about designing a more sensitive and robust assessment instrument as well as the training of echo skills (see Appendix D).

A more powerful assessment instrument could be designed that would be both simple, and capable of assessing a wide variety of variables reliably. For example, participants might be taken to several predetermined places, and instructed to describe the location of objects around them in terms of distance, height, and direction. They might also be instructed to identify objects, or at least provide information about density and composition. This procedure is similar to that used by Magruder (1974). It has the advantage of allowing for highly discrete measurements

of judgement accuracy. It might also be rapidly administered, and should be adaptable to a wide variety of natural or artificial environments. Unfortunately, such an instrument does not actually involve movement, so it does not represent a good measure of echo perception as it applies to mobility. Also, because the assessment is static rather than dynamic, it might quickly wear thin the patience of young children who, in this author's experience, do not like standing around.

Another procedure might involve the assessment of participants as they walked along a predetermined course. The course would have various objects and environmental features along the way. Participants would be instructed to stop at each object or feature that they sense, identify the phenomenon, and locate it by approach. Scoring could be based on percentage of phenomena detected, correct identifications, and location variables such as time and directness. Other indices might also be measured such as walking speed, amount of accidental contact with physical objects, etc. This procedure bares faint similarity to that

used by Boehm (1986). Being a dynamic task, it would constitute a measure of echo perception as it applies to mobility, and would probably hold the attention and interest of young children. However, such an instrument could become quite complicated by the need to find suitable courses, and to match characteristics between the pre-assessment and post-assessment. It might be susceptible to changing environments and layouts, and would not be readily supplemented by artificial means.

The inclusion of multiple trial measures for multiple indices over a large sample should make either procedure resistant to many forms of random error, and flexible to accommodate systematic error. For instance, if the course in the second example involves the possibility of detecting 50 objects spread over 30 cases, the distribution of errors should little effect performance trends.

The program itself has evolved into a constellation of tasks and teaching strategies. (See Appendix A.) The primary elements that must be considered include the amount of time and practice for

each participant. It would be useful to test participants over a year's training. One might train motivated mobility specialists in the techniques for instructing echo-mobility. The experimenter would be responsible for the assessment of improvement. Such a procedure would risk high susceptibility to varying styles of instruction, but this could be minimized by routine training visits from the experimenter, regular contact with the instructors, and the implementation of a prescribed lesson guide. Such a guide would not rigidify training curriculum, but merely provide general guidelines so that all students would receive a similar subset of training experiences. Meticulous notes would be taken on time spent training echo skills for each student as well as any deviations that took place in lesson implementation. This would allow the division of the overall sample into subgroups if necessary, and would provide interpretive information. This procedure would have the advantage of a potentially large sample and a lengthy period of training. Such a procedure might allow the establishment of a control group, although the

heterogeneity of the blind population would make matching difficult. The implementation of lessons by mobility specialists under natural conditions would greatly increase the ecological validity of such a procedure.

Implications and Concluding Remarks

The long term effects of a drastically impaired comprehension of space can be quite deleterious to mobility, and to many other aspects of functioning. Since echo perception variables have been found to correlate highly with mobility performance (Foulke, 1971; Juurmaa, 1965, 1967a, 1967b, 1969; Norris, Spaulding, & Brodie, 1957; Warren & Kocon, 1974), it seems likely that an understanding and implementation of auditory spatial processing should dramatically enhance the effectiveness of mobility training for the blind (Juurmaa, 1972). Blind people could learn to travel much more autonomously with a substantially clearer and more fulfilling perception and comprehension of the world around them.

Improvements in mobility skill may, in turn, lead to increases in self esteem, motivation, and even social development. Mobility skill seems largely to determine general ability to get along in life, and is related to high levels of self-confidence. Graham, Robinson, Lowrey, Sarchin, and Tims (1968), in a study of over 800 blinded veterans, found an almost linear relationship between mobility skill and capacity to earn an independent living. De l'Aune et al (1974) found strong correlations between performance at echo detection and a variety of personal adjustment variables. "... once the problem is squarely faced, and once the possible benefits to the blind are considered in full perspective, who can deny that the potentialities of human echolocation deserve full and rigorous exploration." (Griffin, 1986, p. 322)

Such investigations stand to challenge many of the basic assumptions upon which current theory and practice of orientation and mobility rest. This area of the literature is fraught with the notion that the blind do not have access to continuous or parallel sensory processes for the effective analysis and

comprehension of space (see Strelow, 1985). It is often assumed that stable and reliable points of reference exist only within a blind person's physical reach (brachial space), and that audition is inadequate to provide useful information about such references beyond reach.

Such a perspective does not seem tenable in light of modern investigations into the capacity and function of auditory spatial processing. In a study of how children blind from birth use echolocation, for example, Ashmead, Hill, and Talor (1989) found, "... congenitally blind children utilize at least some of this auditory spatial information, and, moreover, that they coordinate the information with functionally important behavior such as goal directed locomotion" (p. 23). It is clear that echo perception is an aspect of audition which can provide stable, reliable spatial references of immense quantity and richness at considerable range. According to Wiener (1980) "It [audition] helps one to appreciate depth by identifying the existence of space and the distance through space to a reflecting surface or a sound

emitting object" (p. 115). A multitude of empirical studies together with the experiences of the blind and those who know them leave no doubt that audition can provide sufficient information to enhance mobility performance. However, the potentials for deliberately and systematically applying the use of complex echo skills to the enhancement of orientation and mobility have simply gone unrecognized (Ashmead, Hill, & Talor, 1989; Juurmaa, 1972). If the formal training of blind mobility is to evolve, orientation and mobility professionals must concern themselves with the development of techniques and strategies for teaching complex echo skills, and facilitating their application to nonvisual movement. As Wiener (1980) succinctly states, "The traveler who is able to make good use of this source of stimuli [reflected sound] learns to travel in a more sophisticated, more graceful manner than those unable to do so" (p. 156).

This author believes that the results of this study, qualitative and quantitative, show promise, and are worth investigating further. The prospects for further study seem positive in terms of improving

training techniques toward more highly functioning nonvisual mobility. In this author's experience, most mobility specialists and authorities in the field know little about the phenomenon of echo perception or other aspects of auditory spatial processing, or how to improve it through training. They labor under serious misconceptions about the population they attempt to serve. For example, many believe that the reason some blind people sometimes shuffle their feet is that they are uncertain about the terrain that lies ahead. While this may be true for some people under some circumstances, it was observed that many of the participants in this study began shuffling their feet when asked to locate small objects of unknown location. It was clear that the shuffling resulted from an attempt to generate the signals needed to find the objects. As explained earlier, this process of irradiating the environment with acoustic energy to apprehend the nature of that environment runs closely analogous to the process of illuminating the environment with optical energy for a similar purpose. While this study does not advocate foot

shuffling, it seeks to clarify the techniques necessary to optimize mobility by the use of echoes. Examples such as this abound in the qualitative data collected (see Appendix D). This information can and should be used to design more robust investigations into the development of more refined teaching strategies.

Ultimately, such studies as this could pave the way toward the thoughtful integration of echo skills training into standard orientation and mobility curricula - to be taught along side cane travel and other skills. In short, as Amons, Worchel, and Dallenbach put it in 1953 "The implications ... are far reaching ... that all persons, blind but otherwise normal, are capable of learning to perceive obstacles, and that there is no reason other than the lack of courage or the will to learn for any of them leading a vegetative existence in which he has to be lead about." (p. 551) Although much has changed for the blind since the early 1950s, application of studies such as this one may facilitate great strides that must still be made to enhance and refine the skills of

travel for the blind toward increased efficiency,
security, assurance, and grace.

APPENDIX A

TRAINING PROGRAM FOR ECHO-MOBILITY

Lesson Plan

I. ORIENTATION TOWARD STATIC, SOUND EMITTING, GIANT

PANEL IN LATERAL POSITION: low level

continuous noise combined with tapping on the giant panel at 1 foot distance.

A. PREPARATION: The giant panel was positioned

at 7 locations around the participant's head. Positions included directly to the left and right, 45 degrees left and right in front and behind, and directly behind. Low level noise emanates from the target, and the target was tapped on in a slightly irregular rhythmic fashion with moderate rate - about once per 1.5 seconds \pm 0.5 seconds. The participant practices turning directly toward the sound. Orienting responses in this task should be

fairly precise (between 5 and 10 degrees). Most participants were expected to have little difficulty.

B. EXAM: 7 trials - 1 corresponding to each position.

II. ORIENTATION AWAY FROM STATIC, SOUND EMITTING, GIANT PANEL IN LATERAL POSITION: low level continuous noise combined with tapping on the giant panel at 1 foot distance.

A. PREPARATION: The giant panel was positioned at 7 locations around the participant's head. Positions included directly to the left and right, 45 degrees left and right in front and behind, and directly in front. Low level noise emanates from the target, and the target was tapped on in a slightly irregular rhythmic fashion with moderate rate - about once per 1.5 seconds \pm 0.5. The participant practices turning directly away from the sound. Orienting responses in this task were expected to be

somewhat less precise than in the previous lesson (between 10 and 15 degrees).

B. EXAM: 7 trials - 1 corresponding to each position.

III. LOCATION OF STATIC, SOUND EMITTING, GIANT PANEL IN LATERAL POSITIONS: continuous white noise only at 1 foot distance.

A. PREPARATION: The giant panel was positioned at 5 locations - directly to the left and right, 45 degrees to left and right front, and directly in front. Low level noise emanates from the target. The participant was asked to touch the target. Groping was discouraged.

B. EXAM: 5 trials - 1 corresponding to each location.

IV. INITIAL SENSITIZATION TO ECHO CUES: giant panel in front-center position at 6 inch distance.

A. PREPARATION: The target was randomly presented and removed directly in front of the participant's face at a distance of about 6 inches. The participant was asked

to say whether the target was present or not. No restrictions were imposed on the participant's method of echo detection. When the participant had difficulty, the participant was asked to vocalize while the target was presented, removed, and moved toward and away from the participant's face over a distance of about 2 feet. After a few repetitions of this, it was explained that there was a way that many blind people, including myself, use to help them hear objects. Various attempts were made to explain the tongue click. First, the participant was asked to emulate the sound I make. If the participant cannot, then the process was guided verbally. If this was unsuccessful, then, with participant's permission, I point out the relevant oral spots in the participant's mouth using a fresh, sterile tongue depressor dipped in fresh packets of honey. It was then

demonstrated that it was easier for the participant to detect the target when I emit this signal from directly over the participant's head. Finally, the participant was asked to try. [For participants who already use the palatal click, this explanation was omitted, except that it was briefly mentioned that this tongue click was an excellent way to help hear objects.] Additional preparation was then given with the use of the tongue click.

B. EXAM: The target was presented at the same position before each participant's face. A series of 6 trials (3 blank) were conducted with participant asked to use the tongue click. The first trial in this series was never blank.

V. DETECTION OF STATIC PRESENCE VS. ABSENCE AT LEFT AND RIGHT SIDE: giant panel on left or right at 1 foot distance.

A. PREPARATION: The sensation of hearing the target presented directly to the left or right ear was demonstrated. The target was randomly presented and removed directly at either the left or right ear. The participant was asked to say whether or not the target was present. The participant was always told on which side the target was to be present or absent, and had to touch the target when it was present. The participant was specifically instructed to use only one hand, and not to grope.

B. EXAM: 2 series of 5 trials - 1 for the left and the other for the right (3 present and 2 absent for each series). Again, the participant was always told which side to expect the target. The first trial was never blank.

VI. ORIENTATION TOWARD STATIC, LATERAL POSITION AT
CLOSE RANGE: 90 degrees left and right, and

directly behind head at about 15 inches with giant target.

A. PREPARATION: The participant was simply instructed to turn toward the target when prompted. Great precision was not required at this point.

B. EXAM: 6 trials - 2 left, 2 right, and 2 behind head.

VII. ORIENTATION TOWARD STATIC, LATERAL POSITION AT LONG RANGE: 90 degrees left and right, and directly behind head at 6 feet with giant target.

A. PREPARATION: The participant was instructed to turn toward the target when prompted. Great precision was not required at this point. This stimulus was approached by successively increased distances if necessary.

B. EXAM: 6 trials - 2 left, 2 right, and 2 behind head.

VIII. LOCOMOTOR DETECTION OF MEDIUM PANEL: panel in horizontal orientation at about 15 inches distance.

A. PREPARATION: As the instructor and participant walk in an outdoor environment, the instructor carries the panel, and moves it occasionally in front of the participant's face. The participants had to stop when they detected it. The participant was in physical contact with the instructor, so the instructor's panel movements were subtle so as not to be detectable through the participant's contact. Also, the panel was moved discretely, so as not to cause detectable air currents. It may be explained that it was helpful to emit a tongue click of mild intensity from time to time to check the environment ahead, though this task may be easy for many participants without that precaution. The participant was given about 3 seconds to

respond to each presentation. False detections were pointed out. The large panel was used initially with those participants who have difficulty with this exercise.

B. EXAM: The panel was introduced 5 times during this series.

IX. ORIENTATION TOWARD STATIC, FRONT AND BACK LATERAL

POSITION: 45 degrees left and right of front and back at 20 inch range with medium panel.

A. PREPARATION: Front and back left and right positions were demonstrated. The participant was asked to turn toward the target with somewhat greater attention to precision.

B. EXAM: 8 trials - 4 front (2 left and right), 4 back (also 2 left and right).

X. ORIENTATION TOWARD SIMULTANEOUS DISTANCE

DISTINCTION: 2 medium panels at distances from 18 to 36 inches.

A. PREPARATION: Both panels were presented simultaneously at hard left and right, and

about 45 degrees to left and right of front center. The participant was instructed to turn only to one or the other as specified by the instructor. If necessary, the further distance was increased to 4 feet at first in order to clarify the stimulus distinction, then reduced gradually to 36 inches as seems appropriate.

B. EXAM: 4 trials involving each stimulus position - 1 with the stimulus target at frontal and direct left, and 1 with stimulus at frontal and direct right.

XI. ORIENTATION TOWARD STATIC, HORIZONTAL OBLIQUITY:

4 by 6 foot surface at both sides and front - 3 foot distance.

A. PREPARATION: The stimulus was the long panel, supported by two Plexiglas stands. Its height was adjusted so that its upper edge was at least a foot above the participant's head. The panel was placed parallel, and at varying obliquity to the

direction that the participant was facing. participant practices turning toward the surface as squarely as possible. Exact measurements of angular disparity were not taken, but precision was encouraged. The participant may examine the target tactually after each trial. For participants who have difficulty grasping this skill, a speaker emitting the low level white noise was attached to each end of the surface at the level of the participant's face. The speakers were situated to point toward each other rather than outward. With the close proximity of the speakers and the surface acting as a solid backdrop or "shell" to hold the sound, the binaural effect was analogous to a wall of soft noise. The sound was gradually diminished until the participant can respond to the echo stimulus by itself.

B. EXAM: 6 trials - 1 parallel at each side, 1 oblique by 30 degrees at right and left of center, and 1 oblique by 60 degrees at right and left of center.

XII. ORIENTATION AWAY FROM STATIC, HORIZONTAL

OBLIQUITY: 4 by 6 foot surface at either side and behind - same procedure as previous lesson, except that back rather than frontal positions were used, and participant practices facing directly AWAY from the surface. [This was analogous to "squaring off," a mobility technique in which a blind person orients his forward direction by squaring the back of his shoulders (usually by touch) with a flat surface.]

XIII. SHORELINING (walking parallel) BY ECHOES FROM A

STRAIGHT WALL: along a 30 foot wall at 4 feet distance.

A. PREPARATION: The participant was positioned in oblique orientation facing toward and away with respect to a 30 foot stretch of simulated wall at a distance of 4 feet,

and instructed to orient himself and walk forward in a straight line parallel to the wall without touching it. This exercise was practiced with the wall on either side of the participant. The participant should learn to walk a straight line parallel to the wall (+- half a foot) until reaching the end. Measurements of distance were taken at start and finish, and the experimenter walks close behind and to one side so that veering can be monitored. A small degree of erratic veering was permitted at the beginning of each pass. For those who have difficulty with this exercise, parallel travel was practiced with the participant using a 4 foot bar to trail the wall. This should give the participant a sense of straight line as well as parallel travel.

- B. EXAM: 4 trials - 2 for each side, 1 oriented toward, 1 oriented away.

XIV. LOCATION OF STATIC, SOUND EMITTING PANELS IN

FRONTAL, VERTICAL POSITIONS (elevation):

tapping on large panel with continuous noise at
20 inches distance.

- A. PREPARATION: participant stands straight
with back against a wall or column. The
term "straight" was explained to younger
participants if it appears to be necessary
through the course of the exercise, and
younger participants were informed that
they were standing straight. The large
panel was presented at 4 vertical
positions - 3 in front of the participant
(at forehead level, stomach level, and
shin level), and directly over the
participant's head. At each position, the
panel was tilted to direct echoes back to
the participant's face or head.
participant practices touching the target,
or may say the location.
- B. EXAM: 4 trials - 1 at each of the 4 vertical
positions.

XV. LOCATION OF STATIC, VERTICAL POSITION

(elevation): with large panel.

- A. PREPARATION: The participant stands straight with back against a wall or column as before. The participant practices touching the large panel presented at different elevations - above head, forehead, waste, and feet. The panel was slanted to optimize reflections to the participant's face or head. Distance and degree of slant for the lowest position varies according to participant height in order to keep angle of reflection reasonably constant across participants. participants were shown that they could bump their heads if they walk into an object at head level, or trip and fall if they bump into a low object, or hurt themselves by walking into an object at waste level.
- B. EXAM: 8 trials - 2 at each of the 4 vertical positions.

XVI. CENTERING BETWEEN TWO WALLS: 8 feet apart and 12 feet long.

A. PREPARATION: Two, 16 foot walls placed 8 feet apart were the stimuli. participants were placed at different positions between the walls such that the stimuli were directly to either side. participants had to center themselves to within 6 inches of the center. participants were turned around and walked sequitously between trials. Noise generators may be used initially with some participants to assist in this exercise.

B. EXAM: 4 trials - 2 at 18 inches to left and right of center, and 2 at 3 feet to left and right of center.

XVII. SHORELINING AND STOPPING AT OBSTACLE: large obstacle at head level.

A. PREPARATION: The large panel was placed in various positions along the center line of a simulated corridor made up of two, 16 foot simulated walls placed 8 feet apart.

The panel stands vertically, and its upper edge was adjusted to at least half a foot over the participant's head. The participant was asked to walk straight down the center of the corridor, and to stop before touching or colliding with the panel (less than 6 inches). The starting point varies from 8 to 14 feet from the obstacle. Distance was varied by moving the obstacle from one point to another within the corridor while the participant was behind one of the walls and facing away from the apparatus. Also, the participant sometimes starts at one end of the simulated corridor, and sometimes at the other. The method of changing the starting point was not revealed to the participant, although the fact that starting distances vary was made clear. The instructor walks beside and slightly behind the participant on each trial. For purposes of preparation, it may be

necessary to increase the initial distance between participant and obstacle gradually.

- B. EXAM: 6 trials - 3 with the obstacle at 8 feet, and 3 at 14 feet.

XVIII. SHORELINING AND DUCKING OVERHANGS.

- A. PREPARATION: The apparatus for this lesson was exactly as in lesson XVII, but with the overhang instead of the large panel. The participant had to walk down the center of the corridor, and duck the overhang without touching it.

- B. EXAM: 6 trials - 3 with the overhang at 8 feet, and 3 at 14.

XIX. SHORELINING AND STEPPING UP AT A CURB: same procedure as in lesson XVII, but the curb was used instead of the large panel.

XX. SHORELINING BY ECHOES FROM A LOW WALL: wall was 2 feet high and 4 feet distant.

- A. PREPARATION: The participant was positioned in oblique orientation facing toward and away with respect to a 20 foot stretch of simulated low wall at a distance of 4

feet, and instructed to orient himself and walk forward in a straight line parallel to the wall without touching it. This exercise was practiced with the wall on either side of the participant. The participant should learn to walk a straight line parallel to the wall (+- 1 foot) until reaching the end.

Measurements of distance were taken at start and finish, and the experimenter walks close behind and to one side so that veering can be monitored. A small degree of erratic veering was permitted at the beginning of each passage. For those who have difficulty with this exercise, parallel travel was practiced with the participant using a 4 foot stick to trail the wall. This should give the participant a sense of straight line as well as parallel travel.

B. EXAM: 4 trials - 2 for each side, 1 oriented toward, 1 oriented away.

XXII. LOCOMOTOR IDENTIFICATION OF VERTICALLY

POSITIONED ENVIRONMENTAL FEATURES (elevation):

raised curbs or steps; tall planters, trash cans, hoods of parked cars, or fire hydrants; and archways or tree branches.

A. PREPARATION: The participant was introduced to various environmental features that exemplify elevation. Each feature was named, and an appropriate response for each was given where relevant (E.G., step up on to a curb, duck beneath an overhang, stop and examine or avoid mid-height objects). Also, ramifications for failing to respond properly to these things were explained and demonstrated.

B. EXAM: 8 trials - 2 overhangs, 2 low (preferably curbs or steps), and 2 middle features were addressed, and 2 awnings. "What do you think this is?" participant may give the name, the proper response, or just contact the object directly. Any such response was considered correct if it

corresponds to the elevation of the feature.

XXIII. TURNING OUTWARD AND INWARD RIGHT-ANGLE

CORNERS: a 26 foot wall at 3 feet distance.

A. PREPARATION: The participant was positioned parallel to the start of a 26 foot stretch of wall. The wall was constructed to form a corner that turns outward (away) and inward (toward). The corner was located at the center of the wall. The participant walks 3 feet from the wall, and can veer ± 1 foot. Trials were practiced with the wall on either side of the participant.

B. EXAM: Four passes were made - 2 with inward and outward corner on the left, and 2 with inward and outward corner on the right.

XXIV. LOCATION OF RECESS IN A WALL: 2 feet wide by 2 feet deep recess.

A. PREPARATION: The simulated wall was used with one 2 foot by 2 foot recess. The participant practices locating and facing

the recess while walking 2 feet from the wall along a path varying in length from 6 to 12 feet. Trials included wall at both sides.

- B. EXAM: 8 trials - 5 with wall on each side (2 at 6 feet and 2 at 12 feet).

XXV. DETECTION OF STATIC, SMALL PANEL.

- A. PREPARATION: The small panel was randomly presented and removed directly in front of the participant's face at a distance of about 15 inches. participant was asked to say whether or not the panel was present.

- B. EXAM: 6 trials - 3 present, 3 absent.

XXVI. ORIENTATION TOWARD STATIC, SMALL PANEL AT

FRONTAL LATERAL POSITION: 20 inch range.

- A. PREPARATION: Directly to left and right, and 45 degrees to front-left and front-right positions were demonstrated. participant was instructed to turn directly toward the target. If necessary, in order to acclimate the participant to the rigors of the experimental conditions, the concave

surface of the small panel was used at first instead of the flat surface.

B. EXAM: 8 trials - 2 at each position.

XXVII. ORIENTATION TOWARD STATIC, LOW DENSITY PANEL AT FRONTAL LATERAL POSITION: 20 inch range.

A. PREPARATION: Directly to left and right, and 45 degrees to front-left and front-right positions were demonstrated. participant was instructed to turn directly toward the target. If necessary, in order to acclimate the participant to the rigors of the experimental conditions, the concavity surface of the small panel was used at first instead of the flat surface.

B. EXAM: 8 trials - 2 at each position.

XXVIII. ORIENTATION TOWARD STATIC, SIMULTANEOUS DENSITY DISTINCTION: large and low density panels at 20 inches.

A. PREPARATION: The two panels were first presented alternately to accustom the participant to the different characteristics of echoes from the

different surfaces. Then, both panels were presented simultaneously at hard left and right, and 60 degrees to left and right in front, with participant instructed to turn only to one or the other.

- B. EXAM: 8 trials - 4 with each stimulus (2 with the stimulus target at each of frontal and direct left, and 2 with stimulus at each of frontal and direct right).

XXIX. CENTERING BETWEEN TWO POLES: 5 feet apart.

- A. PREPARATION: Two poles set 6 feet apart serve as the targets. The participant learns to center himself to within 1 foot of the center.

- B. EXAM: 4 trials - 2 at 2 feet to left and right of center.

XXX. LOCATING (AND PASSING THROUGH) OPENINGS IN WALLS: Only location was required of participants who did not complete the previous lesson.

A. PREPARATION: The simulated wall was used with one 4 foot opening - bordered by poles to simulate a door frame. The participant practiced locating and turning into the opening from 2 foot distance from the wall along a path varying in length from 6 to 12 feet. Trials included wall at both sides.

B. EXAM: 8 trials - 4 with wall on each side (2 at 6 feet and 2 at 12 feet.

XXXI. LOCATION OF DYNAMIC, SOUND EMITTING, LARGE PANEL IN LATERAL MOTION: 220 degree arc (110 degrees left to 110 degrees right) at 20 inch range.

A. PREPARATION: The large panel, oriented vertically, was moved slowly at a fix range of 20 inches in a random, arc-like pattern spanning from just behind the left ear to just behind the right. The panel was tapped about once per second throughout the entire exercise. participants were asked to touch the

target immediately after prompting. The target had to be contacted within about 2 seconds or it was removed.

- B. EXAM: 5 trials - 2 right and left at 110, 2 right and left at 60 degrees, and 1 at center position.

XXXII. ORIENTATION TOWARD DYNAMIC, LATERAL POSITION:

220 degree arc (110 degrees left to 110 degrees right) at 15 inch range with medium panel - participants who did not complete the lessons involving poles or small panels use the large panel.

- A. PREPARATION: The medium (or large) panel, oriented vertically, was moved slowly at a fix range of 20 inches in a random, arc-like pattern spanning from just behind the left ear to just behind the right. The participant was asked to touch the target, immediately after prompting. The target had to be contacted within about 2 seconds or it was removed. Extra emphasis may be placed on positions past 85 degrees,

because these regions were most difficult to perceive accurately. It was explained that fairly regular tongue clicks of moderate intensity may be necessary to track the object, especially when it passes into peripheral zones that were difficult to scan.

- B. EXAM: 6 trials - 2 right and left at 110, 2 right and left at 60, and 2 at center position.

XXXIII. EVASION OF LARGE, SOUND EMITTING PANEL IN

MOTION: 180 degrees arc.

- A. PREPARATION: From various directions within the 180 degree arc, the large panel with a noise speaker was brought toward the participant at moderate speed from a distance of 42 inches. The participant was asked to move out of the object's path before it touches them.
- B. EXAM: 5 trials - one from directly in front, 1 from 45 degrees left and right of front, and 1 from each side.

XXXIV. EVASION OF MEDIUM PANEL IN MOTION: 180

degrees arc.

A. PREPARATION: From various directions within the 180 degree arc, the medium panel was brought toward the participant at moderate speed from a distance of 42 inches. The participant was asked to move out of the object's path before it touches them. The panel makes no noise. It was explained to the participant that regular tongue clicking may be necessary to track the object.

B. EXAM: 5 trials - one from directly in front, 1 from 45 degrees left and right of front, and 1 from each side.

XXXV. SHORELINING BY ECHOES FROM A ROW OF POLES: 2

foot distance for about 20 feet.

A. PREPARATION: Stimuli consist of 8 Plexiglas poles adjusted to about 1 foot taller than each participant. These poles were spaced about 2 feet apart for a distance of about 18 feet. The participant was positioned

parallel to the first 2 poles (on left and right sides) at a distance of about 2 feet from the line. The participant was instructed to walk straight forward beside the poles without touching them, and to stop when the end was reached. Distances were kept between 1 and 3 feet from the line of poles. Measurements were taken at beginning and end. [For participants who had difficulty with this lesson, each pole was temporarily fitted vertically with a 2 foot by 4 foot Plexiglas panel to accentuate each pole's position. These panels were removed when the participant showed facility with the exercise.]

B. EXAM: 4 trials - 2 on each side.

XXXVI. IDENTIFICATION OF STATIC, LATERAL, VERTICAL

TILT: at 20 inch distance with full length Plexiglas pole and reward.

A. PREPARATION: One of the Plexiglas poles adjusted to about 7 feet was the stimulus. The participant practices

retrieving the reward from the upper end of the pole as the pole was tilted at about 45 degrees from left to right and right to left, or vertically straight. The elevation of the pole's midpoint was at about upper chest. For participants who have difficulty grasping this skill, a white noise emitter was placed at either end as in lesson XI. For this purpose alone, the concave rather than the flat surface of the pole was used so that the noise was held more effectively - thereby accentuating the "wall of noise" effect.

- B. EXAM: 5 trials - 4 tilts (2 left, 2 right), and 1 vertically straight.

XXXVII. LOCOMOTOR, ECHO EXPLORATION OF EXPANDED

ENVIRONMENT: indoor and outdoor.

- A. PREPARATION: Environments were generally scoped out for exploration in advance. participants practiced echo identifying various features of the environment. Features included foliage, chain link or

wrought iron fences, trees and poles or posts, walls of different heights, curbs and steps, awnings, etc. [What they were asked to identify depended on which lessons had been completed.] participants were allowed to explore all features tactually after an echo-based estimate was made.

B. EXAM: 6 distinct types of features were presented for identification. The specific features presented depended on the environment that was available. participants were not permitted to approach closer than about 20 inches for identification, and identifications at greater distances were noted.

APPENDIX B

Materials

Artificial Stimulus Materials

The artificial stimulus targets were made of smooth, 100% transparent, imported, extruded grade Plexiglas in six 240 cm x 120 cm x 0.313 cm sheets, and one 240 cm x 120 cm x 0.625 cm sheet. The six sheets of 0.313 cm thick Plexiglas was prepared as follows: [The corners of all the following panels were rounded, and the edges polished.]

A. 20 120 cm x 60 cm panels. 0.938 cm holes were drilled into these at each corner and half way down each side, 2.5 cm from the edge. A 0.938 cm hole was also drilled at the very center of each panel, and one more drilled 30 cm to either side of the center hole along the length of each panel.

B. One 120 cm x 30 cm and two 60 cm x 30 cm panels into which 0.938 cm holes were drilled half way down each side, 2.5 cm from the edge.

C. One 30 cm x 15 cm panel into which a 0.938 cm hole was drilled half way down each side, 2.5 cm from the edge.

D. Eight 105 cm x 17.5 cm panels. These were bent lengthwise to 90 degrees, and 0.938 cm holes were drilled at 15 cm intervals down both of the long sides, 2.5 cm from the edge and starting 2.5 cm from the end.

In addition to the Plexiglas, one 120 cm x 60 cm piece of thick myllar (about 0.15 cm thick) was used.

Guiding and Measuring

A role of duck tape.

A role of white butcherblock paper.

Dark, wide marker.

A hand held audio cassette recorder.

One cam-corder and about six hours of videotape.

A 12 M tape measure, and a timer.

Attachment Implements

Five dozen 0.625 cm hex bolts (40 1.875 cm length and 20 3.1 cm length), 20 3.7 cm x 0.625 cm slotted machine screws, and 20 1.56 cm x 0.625 cm metal screws.

Four dozen 0.625 cm wing-nuts, five dozen 0.625 cm tennermen nuts, and four dozen 0.625 cm nuts and cap-nuts.

Six dozen metal washers with 0.625 cm inner diameter and 3.1 cm outer diameter.

Five dozen large binder clips.

Three roles of clear strapping or packing tape.

One large tube of polymer bonding agent and Plexiglas scrap used for occasional repairs.

One dozen nylon snap straps and bunji cords for bundling and carrying.

Supporting Materials

45.3 M of 3.1 cm x 0.313 cm hot-rolled steel flatbar. This was cut into 42 75 cm lengths, 21 45 cm lengths, and two 120 cm lengths. All corners were

rounded, and all edges sanded. One 0.625 cm hole was drilled 2.5 cm from each end of each of the 75 cm and 120 cm lengths. A 0.625 cm hole was also drilled 2.5 cm from one end of each of the 45 cm lengths, and this hole by countersunk. Finally, each 45 cm length was bent very slightly about 5 cm from the end with the countersunk 0.625 cm hole. This bend was executed in the direction of the side with the countersink so that the countersink was on the same side as the interior angle of the bend.

13.8 M of 0.625 cm, high grade or stiff aluminum rod. This was cut into 21 65 cm lengths. Each end of each length was then looped into 0.625 cm eyelets within the same plane. Finally, each rod was bent to about 95 degrees, 5 cm from one end in a plane perpendicular to that of the eyelets.

21 120 cm x 7.5 cm x 0.625 cm strips of Plexiglas. One, 0.625 cm hole was drilled at the center of each end of each strip, 2.5 cm from the edge. Two additional 0.625 cm holes were drilled at 30 cm and 60 cm from one end. Each strip was bent to 90 degrees 7.5 cm from the end with the single hole.

Each strip was rigidified by gluing a 2.5 cm x 0.625 cm Plexiglas strip down the edge of the interior angle side - perpendicular to the strip. Finally, the interior angle of each strip was reinforced by gluing a 7.5 cm triangular gusset in the bend, and along side the 0.625 cm rigidifier. (The side holding the gussets and rigidifiers always faced away from the participants, and is referred to henceforth as the "back" of the strips.)

Camouflage Materials

Two square meters of sticky-backed felt.

Five cans of dull gray, rust guard spray paint.

Teaching Aids

Two, ornamental seashells of very different sizes. The smaller of the two was about the size of a baseball, while the larger was about the size of a basketball.

Two spherical, transparent, glass fish bowls of very different sizes. All stickers and labels were removed. These followed dimensions similar to those of the seashells.

A portable audio cassette player, a pair of A.K.G. 240df headphones, and a 90 minute audio cassette of broadband noise (white noise.)

A dozen individually sealed tongue depressors.

One jar of fruit jelly.

APPENDIX C

Assembling the Apparatus

Camouflage and Protection

All metallic pieces were covered with dull gray rust guard paint to prevent glinting. Then, all hex bolts, wing-nuts, and binder clips were covered with bits of sticky felt to protect both participants and Plexiglas from gouging or abrasion. Finally, a rectangular piece of sticky felt was applied to the center of each edge of all the 120 cm x 60 cm Plexiglas panels, and to the top of each Plexiglas support. This was done to prevent abrasion, and also to minimize squeaking sounds that sometimes resulted from Plexiglas pieces rubbing together.

Plexiglas Stands

Each of the 21 bent, 0.625 cm Plexiglas strips was reinforced with aluminum rod, and bolted by the

bent portion with 3.7 cm x 0.625 cm slotted machine screws to two 75 cm lengths and one 45 cm length of steel flatbar as shown in figure 16 and discussed below.

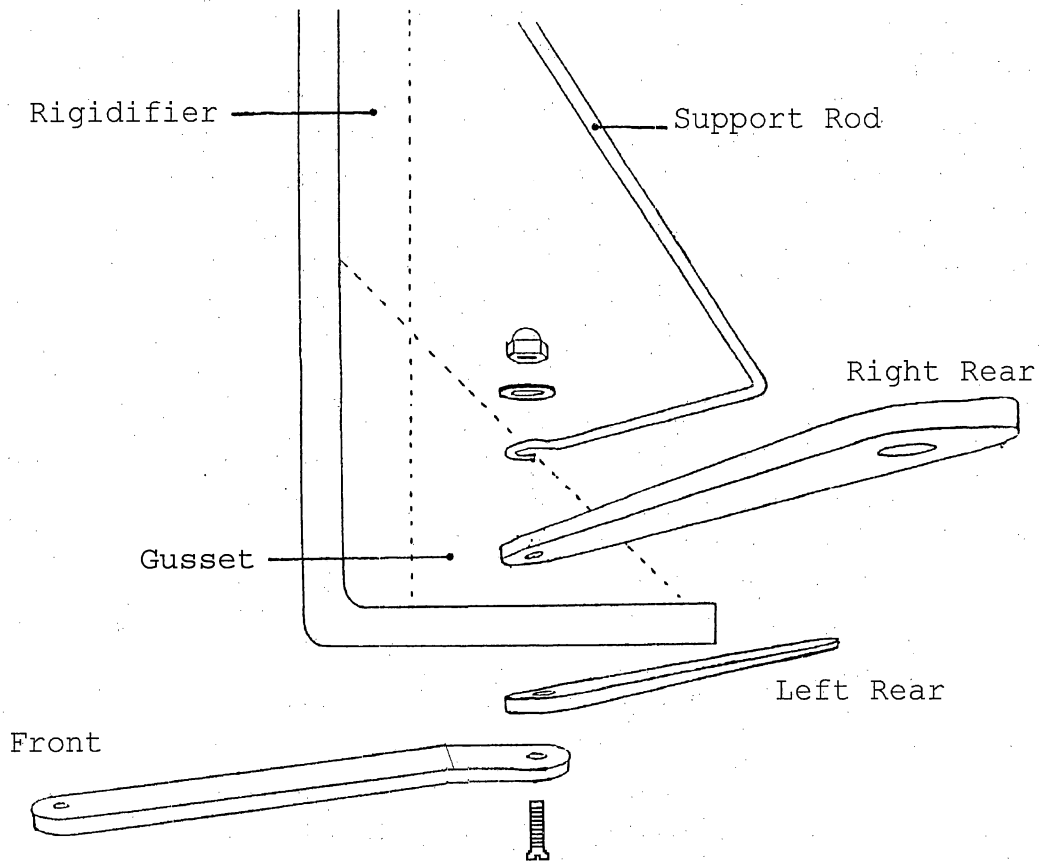

Figure 16. Expanded view of lower stand assembly.

The 21 45 cm steel strips were placed, countersink side down, over the slotted machine screws

so that the sloped head of the screws fitted snugly into the countersink.

Then, one 75 cm steel length was placed over each of these so that the machine screws passed through both steel pieces.

Each of the Plexiglas strips was then fitted at the bent portion over the screws so that the screws past through all three elements.

A second 75 cm steel strip was then fitted over the screw. The Plexiglas pieces rested between each pair of 75 cm steel pieces with the 45 cm strips on the bottom.

The three steel strips (called prongs) were then splayed out to 120 degrees from each other such that the 45 cm prong pointed toward the front of the Plexiglas strips opposite the gussets and rigidifiers as shown in Figure 17. The lower of the pair of 75 cm prongs was pointed in about the same direction as the corners holding the triangular gussets. The remaining upper 75 cm prongs were pointed toward the corner opposite the gussets. With the steel prongs splayed out in this fashion, the Plexiglas stands stood

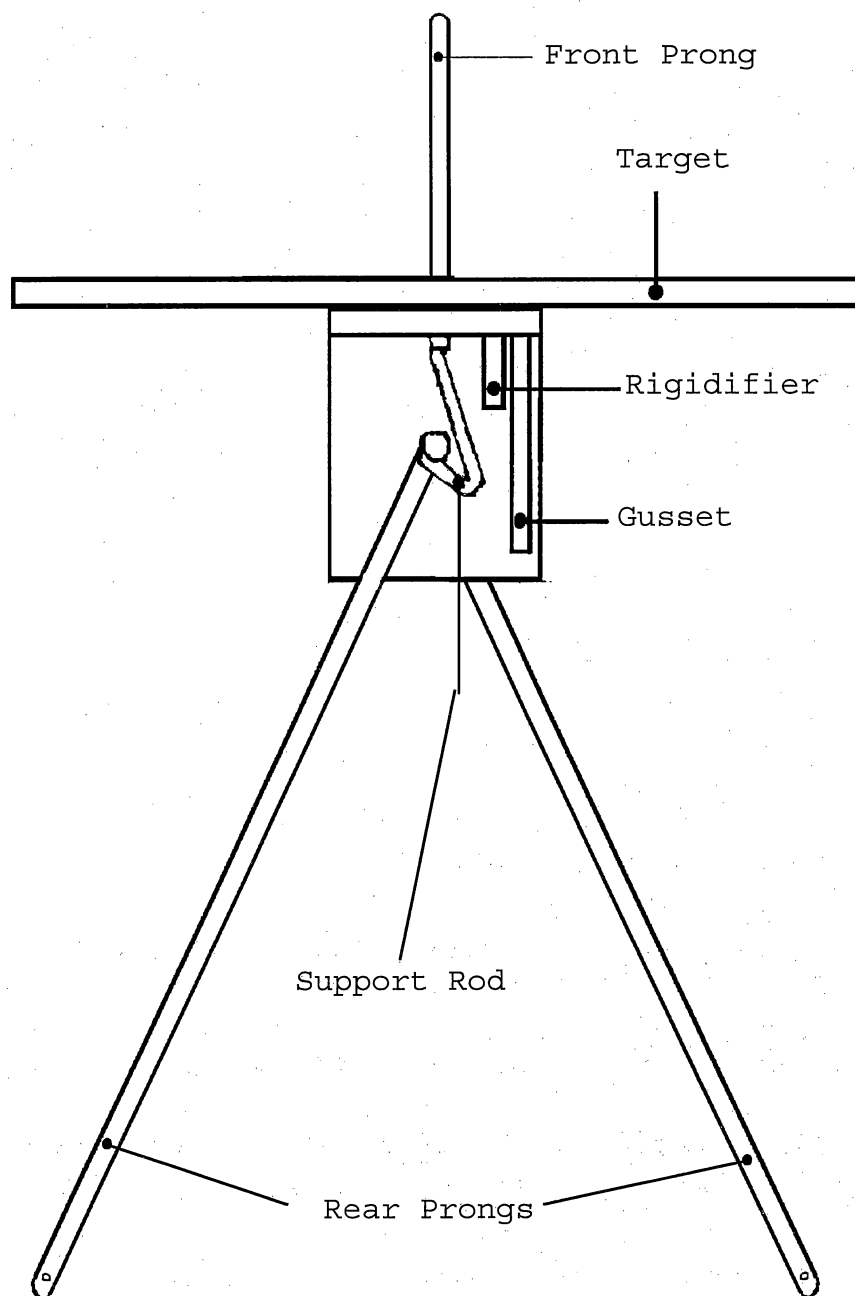

Figure 17. Top view of assembled stand with panel.

upright and leaning slightly backward due to the slight bend in the 45 cm prongs as seen in Figure 18.

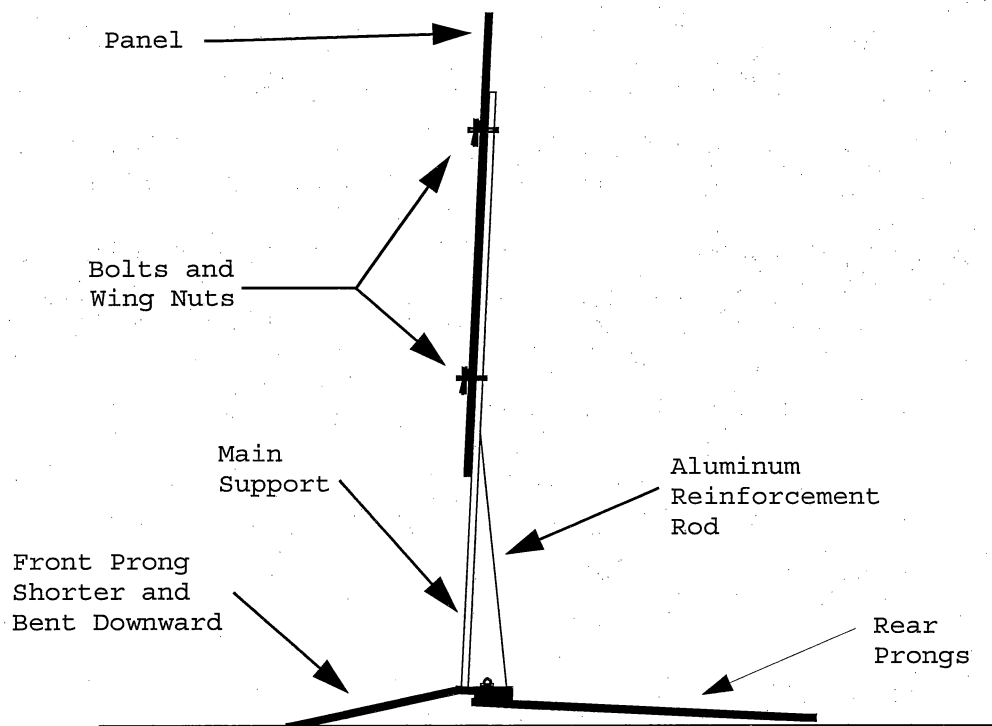

Figure 18. Side view of assembled stand and panel.

At this point, the bent, eyeletted aluminum rods were affixed so that the eyelets at the bent ends slipped snugly over the protruding tops of the machine screws. The interior angle of each bent aluminum rod faced toward the interior angle of its corresponding bent Plexiglas strips.

A washer was then placed over the top of each eyelet. All pieces were bolted together, and cap-nuts were screwed into place. The stands and metal prongs were affixed snugly together, but not so snugly they could not be rotated.

The upper eyelet of the aluminum rods was pressed flat against the back of each Plexiglas strip. This usually required bending the rods near that end slightly so that their eyelets would lay more or less flat against the Plexiglas. A metal washer was placed over each eyelet, and each eyelet was bolted to the hole 60 cm below the top of each Plexiglas strip. This was done by passing a 3.1 cm hex bolt through the washer and the back of each eyelet so that the screw end protruded out the front of the Plexiglas, and then bolting them in place using tennermen nuts. The top eyelets often had to be re-shaped or the rods bent or stretched slightly so that the eyelets would align with the hole. It was necessary to keep the tension on the rods high to provide adequate reinforcement for the Plexiglas strips.

A little over a cm of screw now protruded from the hole mid way down each Plexiglas strip. A second, 0.938 cm hex bolt was affixed through the top hole of each strip in the same manner as the first, and also through the hole midway between them. The Plexiglas was hung on these bolts and fastened in place by wing-nuts.

These stands were finally bolted together in bunches of two or three by the free holes at the end of each 75 cm steel prong. Again, these bolts were snugly tightened, but allowed enough play to rotate the prongs. Joining the stands in this fashion gave them tremendous stability. It also allowed the stands to fold together and unfold easily when the Plexiglas panels were not attached - enabling the apparatus to be erected and dismantled fairly quickly.

The Assessment Track

The butcherblock paper was cut into 12 M strips and taped side by side with clear strapping or packing tape to form a run 1.5 M wide. The paper was then

marked lengthwise into five even divisions with a dark orange marker.

18 of the 20 120 cm x 60 cm Plexiglas panels were arranged lengthwise, end to end on their stands into two, parallel rows that bounded each long side of the paper grid. This created a transparent corridor of sorts about 11 M long and roughly 2.6 M wide. The 75 cm steel prongs at each end of each row of panels were rotated to lie over the paper across the corridor, and were joined end to end by the two 60 cm steel strips. This kept the paper flat and taught, and provided an extremely stable foundation for the Plexiglas panels.

Stimuli

Multiple panels were supported by one Plexiglas stand per panel, and were fastened together by binder clips. The height each stimulus was variable according to the height of the participant. Diagrams of the various combinations are shown in Figure 19 and described below.]

High Wall

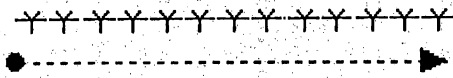

Serpentine Wall

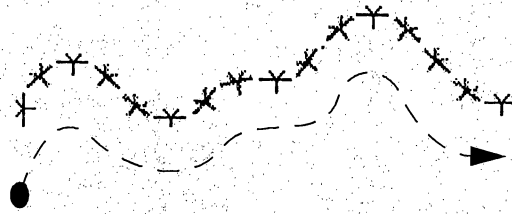

Low Wall

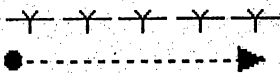

Polygon

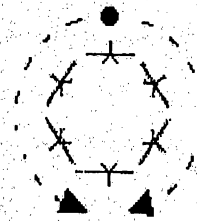

Interior Corner

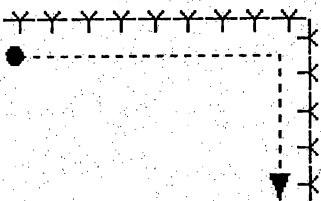

Alcove

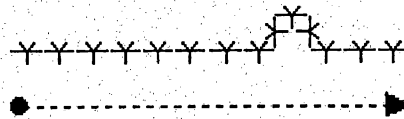

Key	
●	Participant
-▶	Path of travel
⊥	Vertical panel
⊥	Horizontal panel

Figure 19. Different target configuration that yielded different echo mobility tasks.

Giant panel: 120 cm x 120 cm, constructed from two 120 cm x 60 cm panels fastened vertically together side by side.

Long panel: 240 cm x 60 cm, constructed from two 120 cm x 60 cm panels fastened together end to end.

Poles: constructed from the bent, 105 cm x 17.5 cm Plexiglas strips, and fastened with binder clips to the Plexiglas stands.

High wall: consisted of 120 cm x 60 cm panels fastened vertically together side by side. Typically, 15 stands were used to create a wall-like structure about 10 M long and 2 M tall.

Low wall: consisted of 120 cm x 60 cm panels fastened horizontally together end to end. Typically, five stands were used to create a wall-like structure about 6 M long and 0.6 M tall but for the 113 cm supports which stuck up about every 120 cm along the wall.

Interior corner: formed by shaping the high wall into an interior right angle, and fastening the edges of angle together with clear strapping tape.

A serpentine wall: formed from the high wall by fastening every second or third panel at various angles to their adjacent panel with clear strapping tape. It reassembled several, disuniform "S" shapes in succession.

Polygon: formed from six or seven panels fastened vertically by clear strapping tape to each other at appropriate angles to form an enclosed polygon.

Alcove: formed from the high wall by fastening three of its panels into a 60 cm x 60 cm recess or alcove. The angles were slightly more than 90 degrees, and the edges fastened by strapping tape. The alcove was always formed near the middle of the wall.

APPENDIX D

Observations and Considerations of Echo Training Based on 150 Hours of Teaching

Starting Out

In developing and implementing exercises for participants, it was necessary to be creative. While it may be possible to optimize learning through the careful application of formal knowledge and teaching techniques, there's probably nothing that can be done that would prove disastrous except failing to insist on enough practice. Many different things were tried for some participants before success was stimulated. This experimenter believes that something can work for just about every participant. If echo-mobility is addressed and challenged regularly and often, it seems likely that it will flourish in time under many and varied conditions.

Training echo-mobility is somewhat different from training cane technique. Much about cane technique is fairly specific and predetermined - cane length, arc,

rhythm, touch style, arm position, posture, etc.

There is no prescribed way to teach echo-mobility.

While the science behind echo phenomena may be well understood and set in stone, the methods of applying that science certainly are not.

Echo-mobility can be thought of as an art, and its development as an art form. There are a great many things possible depending on the needs of participants, the environment being worked in, the items and materials available, and so on.

Exercises can be designed using materials and environments that are at hand. It is certainly not necessary to use Plexiglas or other synthetic materials. If transparent materials are needed for specific exercises, cheap plastic paneling can be readily purchased at a hardware store or home-improvement center, and scrap can be bought from a plastics shop. Otherwise, cardboard targets, or wood, or even construction or braille paper may be used if it isn't too windy. Notebooks, clipboards, file folders, stuffed animals, boxes and box lids, and many other things can be used successfully.

It is good to start with basic exercises such as orientation skills with large, simple objects. Basic exercises such as the perception of object location and size usually involve little independent movement, and the space in which they take place can be simple. Movement exercises are more complex. Perceiving composition is generally the most difficult— especially for young kids.

When teaching new echo-mobility skills, it was useful to isolate these skills at first from other skills such as cane travel. For instance, when teaching echo shorelining, turning at corners, or long range echo orientation, it seemed best to focus on the echo skill before combining or integrating that skill with cane use. Good echo-mobility skills are no less important than good cane skills, but both are difficult to master. One participant who could turn reliably at a t-intersecting hallway without his cane went crashing straight into the wall when asked to use his cane. Still, both sets of skills should be addressed without exclusion to the other. While using the cane, participants were kept alert to echo cues

around them. And, while teaching new echo skills, participants often carried their canes, even if they weren't actually using them at the moment. Sometimes, they were guided initially so that they could concentrate on the echo cues without interference from mental distraction or anxiety, though this is not recommended as a regular practice. It seemed very difficult for a beginner to attend to all the subtle nuances of echo perception while concentrating on appropriate cane technique and other tactual and kinesthetic cues. Without practice, one cannot tap one's foot to one beat while snapping one's fingers to a slightly different beat. Most can do either task separately, but it takes practice to combine them. Of course, integration is ultimately necessary where mobility skills are concerned, but it seems that the process of fully integrating these skills must be gradual, and learned with much guided practice and travel experience.

When echo-mobility skills did begin to integrate with other skills, the skill levels seemed to drop for

a time until integration was improved. Patience and creativity were required.

When incorporating exercises, three principal aspects of safe travel were born in mind - negotiates objects easily without bodily contact, does not depart accidentally from pathways, crosses streets quickly and efficiently. Effective echo-mobility can greatly facilitates these skills.

A Flexible Hierarchy of Echo-Mobility Development

Static tasks (tasks requiring little movement) seem generally easier than dynamic tasks (tasks where movement is involved). Static tasks simply require less mental processing, and therefore less effort. For instance, it is easier to respond to targets that are stationary than those that are moving relative to the listener. Tracking or following the course of a moving target is generally more difficult than static, directional tasks such as orienting toward or away from a stationary target. It appears that tracking a target in motion involves the organization of three

primary faculties - knowing where the target is going while it moves (mentally following the target), judging how much and in what fashion one must move in order to maintain a certain relationship to the target, and actually executing the appropriate movements. A distinction can be drawn between judging the movement, and actually executing the movement. The former is strictly mental, the latter involves translating a mental perceptual structure into physical action. The judgement must take place before the action, even if the judgement is unconscious. In simply orienting to a stationary target, one does not need to follow the target while it is in motion. One need only make a judgement of direction once the target has stopped moving and is stationary. Even if one chooses to follow the target mentally as it moves rather than waiting for it to stop, following while not engaged in other mental or physical functions is easier than trying to do so while so engaged. To speak generally, many more judgements must be made to hit a moving ball or shoot a moving target than a target that is still.

Larger objects seem generally easier to perceive than smaller ones. Larger objects reflect more sound back to the listener, creating a louder, wider echo. When starting out with skills like static orientation, larger targets were typically used before smaller ones. When progressing to more complex skills like tracking or avoiding targets in motion, instruction returned to the use of larger targets before going back to smaller ones.

Generally, the perception of single targets seemed easier to process than multiple targets or arrays of targets. Determining the location of one target is easier than determining the location of several targets. The exception to this rule involves the comparison of target features such as absorption (soft vs. hard), or dimension. It is much easier to compare two different echo qualities when presented together than at different times. When teaching short vs. tall, for instance, or solid vs. sparse, both targets were presented at the same time in the beginning. Presenting a participant separately with a target made of wood, then a target made of foam and

asking the participant to tell which was the foam was more difficult for the participant than when both targets were presented simultaneously. participants were then asked to distinguish between the two targets directly while they were both within the participants' perceptual field. By analogy, it is easier to match colors when the sets of colors are all in view, rather than being forced to look at everything a piece at a time. Determining which shirt goes with what slacks, or what carpet goes with which drapes is facilitated when the colors are presented next to each other.

Every participant responded differently to the development of echo-mobility skills. No hierarchy of skills can be set in stone. What seemed difficult for one participant was easy for another, and visa-versa. For instance, one could go two ways with the training of static or dynamic skills with large and small targets. One could either start with static tasks involving large targets, and then go to dynamic tasks involving large targets before you progress to static tasks involving smaller targets. Or, one could start with static tasks with large targets, and go to static

tasks with smaller targets before going to dynamic tasks with large targets. In short -

static large to static small to dynamic large,

vs.

static large to dynamic large to static small.

It is not yet clear that either way is better. It seemed to depend on the individual participant. The key was to maintain participants' interest. Sometimes, we would do 15 or 20 minutes of exercises inside with panels of various sizes and arrangements, then go outside for some natural exposure. Of course, not every aspect of mobility training can be a joy, but if the experience is sugared with enough interesting things, then the kids came to enjoy the whole process. Blind people seem generally averse to traveling, but "A spoon full of sugar helps the medicine go down."

Helping the participant maintain interest and motivation is worth far more than the most carefully designed hierarchy of tasks. participant performance

seemed related much more to their motivation than to the experimenter's supposed knowledge of perceptual learning. For instance, it often seemed necessary to intersperse dynamic exercises between static exercises, because it kept participants interested - especially young participants. Once the participants' interest was lost it didn't seem to matter what was done. Sometimes, with some kids, it was necessary to drop what was planned and just go for a walk, or go exploring, or with some other flow. As long as the activity was constructive and informative, there seemed no harm. Mobility skills can still be developed under such circumstances, often better than one's carefully wrought plans. An echo exercise can be made out of just about any activity. Many kids loved to play around with the tether ball. They would be instructed to find tether ball poles with the incentive that one of the poles had a tether ball. They loved it. Sometimes, participants and instructor would play "find the tree," and, when they did, they might get to climb a little way up. Other times it was, "take me to the things you like to play on."

These might be monkey bars, swings, the slide, a merry-go-round, etc. With one kid, the experimenter would pick him up and spin him around in a toy airplane to get him totally disoriented. He had a blast. Then, he would practice finding the slide from where he had been set down. He loved it! Sometimes, it seemed that being a good instructor meant having a good knack for intrigue and entertainment as much as a professional background in blind perception and kinesthesia.

Appropriate Echo Signals

Loud signals are unnecessary in quiet environments such as study places. Since echo signals carry well in quiet places, loud signals can be obtrusive to others, and can yield a lot of unnecessary and confusing information.

Some participants developed the tendency to click very often and rapidly. Partly, this seemed to be a form of self stimulation, but it may also have result from a craving for the information that clicking

provides. It's something like squinting the eyes. However, rapid clicking usually seemed more detrimental to performance than helpful - especially for beginners. Besides being obtrusive, it generally seemed to elicit too much information too quickly to process efficiently. Information from one click tended to blur uselessly into the next. participants were instructed to wait between clicks - to process information from each individual click rather than volleys of clicks.

Kids who used echoes were often unaware that they were doing so. Moreover, they were often unconscious of trying to elicit echoes by such behaviors as tongue clicking, hand clapping, finger snapping, foot scraping, cane banging, or yelling. For example, when one participant with residual vision was asked to close his eyes and show me around campus, his performance was not diminished from that with his eye opened. However, he engaged in increased tongue clicking and foot shuffling of which he was unaware upon questioning. Attention was called to what they were really trying to do. If their endeavors were

obtrusive, they were redirected to more discrete and more useful behaviors.

Young kids can be taught to use echo signals discretely and unobtrusively. Kids who refused to emit echo signals were encouraged strongly to do so when it became clear that their performance on most tasks was vastly improved with signals.

Factors That Effect Echo-Mobility

The distance and detail that echoes can carry seem to depend largely upon the following five factors:

1. QUALITY OF ECHO SIGNAL. In general, strong signals carry furthest, and very short, high pitched signals bring the most detail. A strong signal may carry hundreds of feet under good conditions; a weak signal perhaps a few yards. Signals produced deliberately by the listener usually yield better performance than random sounds from the environment. It appears that listener can rely best on a signal that is under their control, and they are accustomed to the style of information these familiar signals

yield. An analogy can be drawn to the use of glasses. If one's glasses changed their focus randomly, the user would quickly come to hate them. The constancy of one prescription at a time is greatly preferred. The same is true with echo signals. Those signals produced near the ears typically yield clearer echoes, because echoes return most of their energy to the origin of their signal. Thus, echoes from discrete tongue clicks seem easier to interpret than those from cane taps or foot steps. Since echoes are relatively quiet, as much echo energy as possible must be directed to the ears. However, moderately low intensities (the volume of a finger snap) are suitable for most situations. Strong intensities were necessary to perceive objects far away, or through noisy environments.

2. SURFACE CHARACTERISTICS. Large, hard, solid surfaces with concavities or interior angles are usually the easiest to detect at the greatest distances. Also, objects near the head are typically easier than those below the waist. Large objects can camouflage or over shadow small ones that are near

them. Small or sparse objects may require stronger echo signals to detect, but very loud signals can hamper perception when many other objects are present. Wet grass can cast false or confusing images when traversed. Strategic echo signaling seemed to dispel false images, but this required practice. Some participants seemed less effected by false images than others.

3. AMBIENT NOISE CHARACTERISTICS. Background or ambient noise may elicit useful echoes, but it generally served to mask or absorb echoes, because echoes are relatively quiet. The more ambient noise, the more difficult it generally was for participants to perceive echoes. Strong signals such as hand claps or intense tongue clicking were necessary to penetrate loud noise such as very heavy traffic or loud music. Such noise could cut detection distance down to a couple of yards, and detailed information may not be available. Conversely, very quiet environments generally necessitated the use of soft signals for the "clearest" information.

4. QUALITY OF HEARING. Broadly speaking, better hearing enables the highest potential for using echoes. However, while high frequencies are required for the perception of small objects and detail on surfaces, most useful echo skills rely more heavily on mid frequencies. Even if hearing sensitivity is reduced across large portions of the spectrum, effective echo-mobility seemed possible.

5. DEGREE OF VIGILANCE. This is perhaps the most important factor. Because there are many cues that must be analyzed and integrated for successful blind mobility, concentration is often divided among many elements. Since echo information is relatively subtle, it requires at least a moderate degree of continued concentration for effective use.

What Helps or Hinders Echo-Mobility

Too much guided travel will impede the development of echo-mobility over the long term. participants, even young participants, should be

required to travel without physical guidance except under rare circumstances.

Rain does not necessarily interfere with echo-mobility, but it can be very distracting.

The perception of echoes may be slightly improved in cold weather or after rain. Sound waves tend to travel better in cold air, and wet objects tend to reflect more sound energy.

Strong winds or noise will hamper echo-mobility. A strong echo signal is necessary for good perception under these conditions.

Anything that covers or shadows the ears such as umbrellas, hoods, and hats can strongly interfere with echo-mobility. A strong signal will not help.

Age Factors

With blind kids under six or seven, perception of composition and object identification were especially difficult. These require relatively good attention, analytical skills, and contextual knowledge - all of which tend to increase with age.

Concepts of near and far tended to be hard for young kids, but they usually responded when asked: "Which one is the easiest to touch?" Centering or going between are also ideas not understood by young kids.

Young children were more inclined to touch everything, and had difficulty maintaining necessary vigilance and concentration. While touching is not a bad thing, young kids were frequently reminded that they were doing "listening" games rather than touching games.

Children under six or seven rarely understood that their sense of surrounding comes from hearing. Asking them to listen for silent objects just seemed to confuse and even agitate them. It was best not to refer to echoes as auditory with young kids. If reference was made to "listening" game, it was done matter-of-factly, and they rarely challenged such references. Eventually, they seemed to get the idea. Older kids, however, generally understood, and could make use of the knowledge that their perceptions come from auditory echoes.

Residual Vision

Most functionally or educationally blind people possess a small amount of residual vision - too little for a visual acuity rating. Typically, this vision seems to have little use; these people generally seem to function as if totally blind. However, the perception of light sometimes made it difficult to assess echo-mobility. It was often hard to know for sure whether the participant knew of the parked truck or tree from echoes or the blockage of sunlight. Echo information often surpassed visual information for those with very poor or marginal vision - especially concerning long range perception. Therefore, a blindfold was used for some lessons. to help turn the attention of the participant to echo cues, and facilitate their application to mobility.

participants with light perception or visual memories often confused echo images with visual images. They seemed to see what they heard. They would say: "I can still see the wall," even under a blindfold. The brain can interpret echo sensation in

a visual reference - causing confusion between the sensory channels. Except to very young children, the difference between what participants saw, and what they heard was explained to them. The strategic use of blindfolds and headphones was helpful here. One with poor vision over strained his eyes. But when the use of echoes was brought to his attention and refined, he found it less necessary to strain. He came to depend only partly on his vision for obstacle detection, but came to use a strong click to ascertain his orientation to distant objects. This finding is especially relevant to those with fragile eye conditions.

Special Notes

participants often had surprising difficulty locating narrow objects like poles, even when they had perceived the presence of the object. Random search patterns were common - especially for young children. In the beginning, the participant was always instructed to turn and face the object first, then

move straight toward it. Sometimes, participants had to be reminded to keep facing the object while they searched.

When a participant was traveling in a circle around an object, telling the participant not to "loose" the object was helpful. The perception of increasing distance seemed subtle for some beginners, and needed to be reinforced. If the participant appeared to be lost, asking him to turn and face the object, then to return to the object and try again seemed helpful. They could often do this from impressive distances.

Low objects such as curbs seemed taller to some participants from several feet away than they actually were. These were difficult to perceive up close.

It was found helpful to instruct participants in the recognition of specific surface characteristics such as those covered in the table. It was observed that many participants had a very difficult time describing objects and features that they perceived through echoes. When confronted with two different targets - tall vs. short, big vs. small, close vs.

far, etc. - many participants were reliably aware that some difference was present, but they often could not state the nature of the difference. For example, participants were instructed to walk parallel to a wall that changed distance abruptly from 60 cm to 120 cm from them. Many of the participants were easily able to recognize a change in the wall. When asked to describe this change, one 12 year old stumbled greatly over his explanation. "The wall widens. ... It - how can I describe it? It sort-of is opened, or something like that. ... It changes directions - not directions but..." In various wall following exercises, this participant and others demonstrated a functional awareness of the walls' changing distance. This participant could, for example, maintain a constant distance from this wall or a curved wall while walking. It was semantic knowledge that seemed lacking. It was as though the children lacked discrete, verbal, descriptive references to their surroundings. My impression is that this arises from little practice on the part of blind people, especially children, to describe their echo

perceptions, or attend to them as discrete and concrete perceptions. Descriptive language is typically based on visual references - distance, direction, color, texture, etc. Little if any encouragement is typically offered to blind children to fashion their own descriptive frames of references based on auditory perceptions - particularly echoes. It seemed important, therefore, to help participants develop auditory based frames of references. It seemed that, in this way, participants grew able to establish clearer relationships between themselves and other objects, and among the surfaces of other objects. This author further submits that this may facilitate the development of spatial reasoning skills that may broaden general and basic comprehension of spatial layouts and contexts.

Children often seemed unaware of improvements or decrements in their mobility as a result of proper or ill use of techniques. It seemed appropriate to take their comments and observations into consideration, but care was taken to confirm their verbal accounts by carefully observing specific behaviors.

It was important to keep in mind that, just because participants didn't seem able to do something did not mean that they really could not. Sometimes, it was simply necessary to ask in the right way. This is especially true with young kids. For example, asking young participants for verbal responses was generally much less effective than requiring a specific action from them. Asking them to tell where the target was often got me nowhere, but they could often go to the target, or reach for it. Younger participants were often not able to turn their body and face the target as it moved around them in a tracking exercise, but they often tracked the target instinctively with their head even so.

Often, it was necessary to keep talking in order to help some children maintain their attention. Blind kids seem to have attention spans far greater than sighted peers, but they can be completely distracted by the slightest noise, or even the thought of a noise. Talking to them helped keep them focussed on the here and now.

It was sometimes found that great strides seemed to be made one day or week, only to fall back by the next few sessions. Performance seemed highly variable for many participants. It seems that blind mobility is extremely difficult, and is therefore readily affected by the mental state of the traveler— especially in children. It seems to take a good deal of practiced discipline and traveling experience to reduce the negative effects that mental distraction can have on the performance of nonvisual mobility. It is easy for a sighted person to travel while distracted, because visual mobility is very simple. Sighted people almost always have easy access to far more information than they need. The processes involved in mobility are highly simplified for them. The blind, on the other hand, encounter much greater complexity. First, they must work very hard to acquire their information, and, despite the extra work, the information available is usually lacking in many crucial respects. Second, the blind must make up for insufficient information by applying highly intensive cognitive skills to fill in the gaps. If

someone presents a sighted person with a faded, blurred, photograph, he'd have to think about it for a while before he could decide what he was seeing. The blind must engage in this extra processing at every step and every nuance of movement. The load upon the mind can be immense. Therefore, the slightest draw upon the mind seems to affect the blind person's ability to effectively manage this load. Consider the race car driver. He cannot be thinking much about his personal problems while negotiating hair-pin turns at hundreds of miles an hour with a swarm of other drivers all fighting for the lead. Likewise, the blind traveler cannot find proper footing and maintain good balance, negotiate random arrays of all sorts of objects, and maintain his sense of direction and overall spatial awareness at a reasonable gait while otherwise mentally engrossed. It seems that blind people must learn early to focus themselves in their travel, and reckon with the consequences of failing to do so. Intensive training and extensive practice would seem likely to yield the greatest success. There seem to be two main keys here that must pervade

all facets of mobility instruction - developing mental discipline in blind travelers so that they are more likely to keep a large percentage of their minds focussed on mobility, and developing the skill of mobility to such a high degree that a slight decline in performance doesn't prove hazardous. Both of these keys require extensive practice and experience on the part of the blind traveler, and sustained yet patient attention on the part of the instructor.

REFERENCES

- Amendola, R. (1991). Vidiation and spatial orientation. Carroll Center for the Newton, Massachusetts: Blind.
- Ammons, C. H., Worchel, P., & Dallenbach, K. M. (1953). "Facial vision": The perception of obstacles out of doors by blindfolded and blindfolded-deafened subjects. American Journal of Psychology, 66(4), 519-553.
- Armstrong. (1975). Evaluation of man-machine systems in the mobility of the visually handicapped. In R. M. Pickett & T. J. Triggs (Eds.), Human factors in health care (pp. 333-342). Lexington, KY: Lexington Books.
- Ashmead, D. H., Hill, E. W., & Talor, C. R. (1989). Obstacles perception by congenitally blind children. Perception and Psychophysics, 46 425-433.
- Ayrapetyants, E. Sh. & Konstantinov, A. I. (Eds.). (1974). Echolocation in nature. Arlington, Virginia: Joint Publications Research Service.
- Barth, J. L. & Foulke, E. (1979). Preview: A neglected variable in orientation and mobility. Journal of Visual Impairment and Blindness, 73(2), 41-48.
- Bassett, I. G. & Eastmond, E. J. (1964). Echolocation: Measurement of pitch vs. distance for sounds reflected from a flat surface. Journal of the Acoustical Society of America, 36, 911-916.
- Beurlé, R. L. (1951). Electronic guiding aids for blind people. Electronic Engineering 23(1), 2-7.

- Bilsen, F. A., Frietman, E. E., & We-illems, W. (1980). Electroacoustic obstacle simulator (eos) for the training of blind persons. International Journal Rehabilitation Research, 3(4), 553-557.
- Boehm, R. (1986). The use of echolocation as a mobility aid for blind persons. Journal of Visual Impairment and Blindness, 80(9), 953-954.
- Clarke, N. V., Pick, G. F., & Wilson, J. P. (1975). Obstacle detection with and without the aid of a directional noise generator. American Foundation for the Blind, Research Bulletin, 29, 67-85.
- Cotzin, M. (1942). The role of audible frequencies in the perception of obstacles by the blind. Psychological Bulletin, 39 503-504.
- Cotzin, M. & Dallenbach, K. M. (1950). Facial vision: The role of pitch and loudness in the perception of obstacles by the blind. American Journal of Psychology, 63(4), 485-515.
- De l'Aune, W., Gillespie, G. M. (1974). Examination of possible pure tone audiometric correlation with successful acoustic environmental analysis by blinded veterans. IRCS Journal of International Research Communications, 2, 1110.
- De l'Aune, W., Gillespie, G. M., Carney, J., & Needham, W. (1974). Analysis of ambient noise frequencies used by blind patients in the detection of open and closed spaces. Paper presented at the meeting of the Eastern Psychological Association, Philadelphia, PA.
- De l'Aune, W., Scheel, P., & Needham, W. (1974). A comparison of acoustic environmental analysis by blinded veterans and sighted high school students. IRCS Journal of International Research Communications, 2, 1213.

De l'Aune, W., Scheel, P., Needham, W., & Kevorkian, G. (1974). Evaluation of a methodology for training indoor acoustic environmental analysis in blinded veterans. In R. A. Foulds, & B. L. Lund (Eds.) Proceedings of the Conference on Engineering Devices in Rehabilitation (pp. 26-30). Boston, MA: New England School of Medicine.

Diderot, D. (1749). Lettre sur les aveugles, Textes litteraires francais: Geneva, Croz, 1951, 10-11.

Dolanski, V. (1930). Le aveugles possedent-ils le "sens des obstacles" [Possession by the blind of a "sense of obstacles"]. Annee Psychologique, 31, 1-51.

Dolanski, V. (1931). Do the Blind Sense Obstacles. In And There was Light, 1, 8-12

Felts, W. (1909, September 25). Supersensitiveness of the blind. Scientific American, 101, 215.

Foulke, E. (1971). The Perceptual basis for mobility. American Foundation for the Blind, Research Bulletin, 23, 1-8.

Garrison, D. (Executive Producer). (1994, December 27). The Other Side. Burbank: NBC.

Garry, R. J. & Ascarelli, A. (1960). Teaching topographical orientation and spatial orientation to congenitally blind children. Journal of Education, 143(2), 1-48.

Graham, M. D., Robinson, R. L., Lowrey, A., Sarchin, M. M., & Tims, F. (1968). Eight hundred fifty-one blinded veterans: A success story. New York, New York: American Foundation for the Blind.

- Greystone, P. & McLennan, H. (1968). Evaluation of an audible mobility aid for the blind. American Foundation for the Blind, Research Bulletin, 17, 173-180.
- Griffin, D. R. (1974). Listening in the dark. New York: Dover.
- Griffin, D. R. (1986). Listening in the dark; the acoustic orientation of bats and men. Ithaca, New York: Comstock Publishing Associates. (Reprinted from Listening in the dark; the acoustic orientation of bats and men, 1958, New Haven, Yale University Press. Also published 1974, New York, Dover.)
- Hart, V. (1980). Environmental orientation and human mobility. In R. L. Welsch & B. B. Blasch, (Eds.), Foundations of orientation and mobility (pp. 9-36). New York: American Foundation for the Blind.
- Hausfeld, S., Power, R. P., Gorta, A., & Harris, P. (1982). Echo perception of shape and texture by sighted subjects. Perceptual Motor Skills, 55(2), 623-632.
- Hayes, S. P. (1935). Facial vision or the sense of obstacles, (12). Watertown, MA: Perkins Institution.
- Hayes, S. P. (1938). The psychology of the blind. In H. Lynn (Ed.), What Are the Blind? Watertown, MA: Perkins Institution.
- Henson, O. W. & Schnitzler, H. -U. (1980). Performance of air-born sonar systems II: Vertebrates other than micro-kyroptera. In R. G. Busnel & J. F. Fish (Eds.), Animal sonar systems (pp. 183-195). New York: Plenum Press.

- Hill, E. W., Rieser, J. J., Hill, M. -M., Hill, M., Halpin, J., & Halpin, R. (1993). How persons with visual impairments explore novel spaces: Strategies of good and poor performers. Journal of Visual Impairment and Blindness, 87, (8) 295-301.
- Ifukube, T., Sasaki, T., & Peng, C. (1991). A blind mobility aid modeled after echolocation of bats. IEEE Transactions on Bio-Medical Engineering, 38(5), 461-466.
- Jansson, G. (1989). Early mobility training of children born blind: Needs and prerequisites. In M. Brambring, F. Losel, H. Skowronek, (Eds.), Children at risk: Assessment, longitudinal research, and intervention. (pp. 416-426). Berlin; New York: W. de Gruyter.
- Jerome, E. A. & Prochanski, H. (1947). Research on guidance devices and reading machines: Final report. New York: Haskins Laboratories.
- Jerome, E. A. & Prochanski, H. (1950). Factors in the assay and use of guidance devices. In P. A. Zahl (Ed.), Blindness: Modern approaches to the unseen environment (pp. 462-494). New York: Hafner Press.
- Jones, B. (1975). Spatial Perception in the blind. British Journal of Psychology, 66(4), 461-472.
- Jones C. G. E. F. & Myers S. O. (1954). Obstacle experiments. The Teacher of the Blind, 42(6), 153-158.
- Juurmaa, J. (1965). An analysis of the components of orientation ability and mental manipulation of spatial relationships (28). Helsinki, Finland: Institute of Occupational Health.

- Juurmaa, J. (1967a). Ability structure and loss of vision. American Foundation for the Blind Research Series, Vol. 18. New York: American Foundation for the Blind.
- Juurmaa, J. (1967b). The ability structure of the blind and the deaf: Final report. American Foundation for the Blind, Research Bulletin, 14, 109-121.
- Juurmaa, J. (1968a). The effects of training on the perception of obstacles without vision: Part 1. New Outlook for the Blind, 64, 65-72.
- Juurmaa, J. (1968b). The effects of training on the perception of obstacles without vision: Part 2. New Outlook for the Blind, 64, 104-118.
- Juurmaa, J. (1969). Analysis of orientation ability and its significance for the rehabilitation of the blind. Scandinavian Journal of Rehabilitation Medicine, 1(2), 80-84.
- Juurmaa, J. (1970a). On the accuracy of obstacle detection by the blind: Part 1. New Outlook for the Blind, 64(3), 65-72.
- Juurmaa, J. (1970b). On the accuracy of obstacle detection by the blind: Part 2. New Outlook for the Blind, 64(4), 104-118.
- Juurmaa, J. (1972). The spatial sense of the blind: a plan for research. American Foundation for the Blind, Research Bulletin, 24, 57-64.
- Juurmaa J. & Järvillehto, S. (1969). On the accuracy of obstacle detection by the blind (67). Helsinki, Finland: Institute of Occupational Health.
- Juurmaa, J., Suonio, K., Moilanen, A. (1968). The effect of training in the perception of obstacles without vision (55). Helsinki, Finland: Institute of Occupational Health.

- Kellogg, W. N. (1964). Sonar system of the blind. American Foundation for the Blind, Research Bulletin, 4, 55-69. (Reprinted from Sonar system of the blind. Science, 137(3528), 399-405 by W. N. Kellogg, August 10, 1962.)
- Kohler, I. (1964). Orientation by aural clues. American Foundation for the Blind, Research Bulletin, 4, 14-53.
- Kohler, I. (1967). Facial vision rehabilitated. In R. G. Busnel (Ed.), Animal Sonar Systems. (pp. 89-114) Biology and bionics: Jouy-en-Josas, Laboratoire de Physiologie Acoustique, volume I.
- Ladefoged, P. & Traill, A. (1994). Clicks and their accompaniments. Journal of Phonetics, 22, (1) 33-64.
- Landau, B., Gleitman, H., & Spelke, E. (1981). Spatial knowledge and geometric representation in a child blind from birth. Science, 213(4513), 1275-1278.
- Landau, B., Spelke, E. S., & Gleitman, H. (1984). Spatial knowledge in a young blind child. Cognition, 16(3), 225-260.
- Laufer, H. (1948). The detection of obstacles with the aid of sound directing devices. The Biological Review, 10, 30-39.
- Lee, D. N., van der Weel, F. R. (Ruud), Hitchcock, T., Matejowsky, E., Pettigrew, J. D. (1992). Common principles of guidance by echolocation and vision. Journal of Comparative Physiology, 171(5), 563-571.
- Lende, H. (1940). Books about the blind: A bibliographical guide to literature relating to the blind. New York: American Foundation for the Blind.

- Leonard, J. A. (1972). Studies in blind mobility. Applied Ergonomics, 37, (3) 37-46.
- Loomis, J. M., Klatzky, R. L., Golledge, R. G., Cicinelli, J., Pellegrino, J. W., & Fry P. A. (1993). Nonvisual navigation by the blind and sighted: Assessment of path integration ability. Journal of Experimental Psychology: General, 122(1), 73-91.
- Magruder, M. (1974). The Use of Sound in the Perception of Objects. Unpublished master's thesis, California State University, Los Angeles.
- Martinez, F. (1977). Does auditory information permit the establishment of spatial orientation? Experimental and clinical data with the congenitally blind. Annee Psychologique. 77(1), 179-204.
- McCarty, B. & Worchel, P. (1954). Rate of motion and object perception in the blind. New Outlook for the Blind, 48, 316-322.
- Mickunas, J. & Sheridan, T. V. (1963). Use of an obstacle course in evaluating mobility for the blind. American Foundation for the Blind, Research Bulletin, 3, 35-54.
- Middlebrooks, J. C. & Green, D. M. (1991). Sound localization by human listeners. Annual Review of Psychology, 42, 135-159.
- Mills, A. W. (1961). Sonic object sensing. In J. W. Linsner (Ed.), Proceedings of the mobility research conference (pp. 48-50). Washington, DC: Massachusetts Institute of Technology.
- Mills, A. W. (1963). Auditory perceptions of spatial relations. In L. L. Clark (Ed.), Proceedings of the international congress on technology and blindness: Vol. 2 (pp 111-139). New York: American Foundation for the Blind.

- Myers, S. O. & Jones, C. G. E. F. (1958). Obstacle experiments: Second report. The Teacher of the Blind, 46(2), 47-62.
- Nicolosi, M. (1994, December 27). Sound technique aids the blind. The Orange County Register, pp. Metro1, Metro4.
- Norris, M., Spaulding, P. J., & Brodie, F. H. (1957). Blindness in children. Chicago: University of Chicago Press.
- Ono, H., Fay, A., & Tarbell, S. E. (1986). A "visual" explanation of facial vision. Psychological Research, 48(2), 57-62.
- Rice, C. E. (1967a). The human sonar system. In R. G. Busnel (Ed.), In R. G. Busnel (Ed.), Animal sonar systems; Biology and Bionics. Vol. 2, (pp. 719-775). Jouy-en-Josas, Italy: Laboratoire de Physiologie Acoustique.
- Rice, C. E. (1967b). Human Echo Perception. Science, 156, 656-664.
- Rice, C. E. (1967c). Quantitative measures of unaided echo detection in the blind: Auditory echo localization. In R. Dufton (Ed.), Proceedings of the international conference on sensory devices for the blind (pp. 89-102). London, England: St. Dunstan's.
- Rice, C. E. (1969). Perceptual enhancement in the early blind. Psychological Record, 19, 1-14.
- Rice, C. E. (1970). Early blindness, early experience, and perceptual enhancement. American Foundation for the Blind, Research Bulletin, 22, 1-20.
- Rice, C. E. & Feinstein, S. H. (1965a). Sonar system of the blind: Size discrimination. Science, 148, 1107-1108.

- Rice, C. E. & Feinstein, S. H. (1965b, December). The influence of target parameters on a human echo detection task. Paper presented at the 73rd annual convention American Psychological Association, Menlo Park, California, pp. 65-66.
- Rice, C. E., Feinstein, S. H., & Schusterman, R. J. (1965). Echo detection ability of the blind: Size and distance factors. Journal of Experimental Psychology, 70(3), 246-251.
- Rieser, J. J. (1990). Development of perceptual/motor control while walking without vision: The calibration of perception and action. In H. Bloch, & B. Bertenthal (Eds.), Sensory-motor organizations and developemnt in infancy and early childhood (pp. 379-405). Dordrecht, Netherlands: Kluwer Academic Publishers.
- Riley, L. H., Luterman, D. M., & Cohen, M. F. (1964). Relationship between hearing ability and mobility and a blinded adult population. The New Outlook for the Blind, 58, 139-141.
- Schwartz, M. (1984). The role of sound for space and object perception in the congenitally blind infant. Advances in Infant Research, 3, 23-59.
- Schenkman, B. N. (1983). Human echolocation as a function of kind of sound source and object position (363). Uppsala, Sweeden: Uppsala University, Department of Psycology.
- Schenkman, B. N. (1985a). Human echolocation with different types of sound and different positions of sound source (373). Uppsala, Sweeden: Uppsala University, Department of Psycology.
- Schenkman, B. N. (1985b). Human echolocation: A review of the literature and a theoretical analysis (379). Uppsala, Sweeden: Uppsala University, Department of Psycology.

- Schenkman, B. N. & Jansson, G. (1986). The detection and localization of objects by the blind with the aid of long-cane tapping sounds. Human Factors, 28(5), 607-618.
- Shephard, R. H. & Howell, D. A. (1980). "I can no longer hear the silence of lamp posts." Lancet, 2(8196), 706.
- Shingledecker, C. A. (1983). Measuring the mental effort of blind mobility. Journal of Visual Impairment and Blindness, 77(7), 334-39.
- Shingledecker, C. A. & Foulke E. (1978). A human factors approach to the assessment of the mobility of blind pedestrians. Human Factors, 20, 273-286.
- Strelow, E. R. (1985). What is needed for a theory of mobility: Direct perception and cognitive maps - lessons from the blind. Psychological Review, 92(2), 226-248.
- Strelow, E. R. & Brabyn, J. (1982). Locomotion of the blind controlled by natural sound cues. Perception, 11, 635-640.
- Supa, M., Cotzin, M., & Dallenbach, K. M. (1944). "Facial vision": The perception of obstacles by the blind. American Journal of Psychology, 57(2), 133-183.
- Taylor, J. G. (1962). The behavioral basis of perception. New Haven:Yale University Press.
- Twersky, V. (1950). On the scattered reflection of scalar waves from absorbant surfaces (EM22). New York: Washington Square College of New York University, Mathematics Research Group.
- Twersky, V. (1950). On the theory of non-specular reflection of sound. Journal of the Acoustical Society of America, 22, 539-546.

- Twersky, V. (1951a). On the physical basis of the perception of obstacles by the blind. American Journal of Psychology, 64, 409-416.
- Twersky V. (1951b). Flashsounds and aural constructs for the blind. Physics Today, 4, 10-16.
- Twersky, V. (1953). Auxiliary mechanical sound sources for obstacle perception by audition. Journal of the Acoustical Society of America, 25, 156-157.
- Warren, D. H. (1989). Issues in assessment and intervention with blind infants and children. In M. Brambring, F. Losel, Skowronek, (Eds.), Children at risk: Assessment, and longitudinal research and intervention. (pp. 119-135). Berlin; New York: W. de Gruyter
- Warren, D. H. (1974). Early vs. late vision: The role of early vision in spatial referent systems. New Outlook for the Blind, 68,(4) 157-162.
- Warren, D. H. Anooshian, L. J. Bollinger, J. G. (1973). Early vs. late blindness: The role of early vision in spatial behavior. American Foundation for the Blind, Research Bulletin, 26, 151-170.
- Warren, D. H. & Kocon, J. A. (1974). Factors in the successful mobility of the blind: A review. American Foundation for the Blind, Research Bulletin, 28, 191-218.
- Wegel, R. L. & Lane, C. E. (1924). The auditory masking of one pure tone by another and its probable relation to the dynamics of the inner ear. Physiological Review, 23, 266-285.
- Welch, J. (1964). A psycho-acoustic study of factors affecting human echolocation. American Foundation for the Blind, Research Bulletin, 4, 1-13.

- Wiener, W. R. (1980). Audition. In R. L. Welsch & B. B. Blasch (Eds.), Foundations of orientation and mobility (pp. 115-184). New York: American Foundation for the Blind.
- Wilson, J. P. (1967). Psychoacoustics of obstacle detection using ambient or self-generating noise. In R. G. Busnel (Ed.), Animal sonar systems; Biology and Bionics. Vol. 1 (pp. 89-114). Jouy-en-Josas, Italy: Laboratoire de Physiologie Acoustique.
- Witcher, C. M. & Washington, L. Jr. (1954). Echo-location for the blind. Electronics, 27, 136-137.
- Worchel, P. & Berry, J. H. (1952). The perception of obstacles by the deaf. Journal of Experimental Psychology, 43, 187-194.
- Worchel, P. & Dallenbach, K. M. (1947). "Facial vision": Perception of obstacles by the deaf-blind. American Journal of Psychology, 60, 502-553.
- Worchel, P. & Mauney, J. (1950). The effect of practice on the perception of obstacles by the blind. Journal of Experimental Psychology, 41, 170-176.
- Worchel, P., Mauney, J., & Andrew, J. (1950). The perception of obstacles by the blind. Journal of Experimental Psychology, 40, 746-751.
- Zemtsova, M. I., Kulagin J. A., & Novikova, L. A., (1962). The use of the remaining sensory channels (safe analyzers) in compensation of visual function in blindness. American Foundation of the Blind Research Bulletin, 2, pp. 72-87.