

California State University, San Bernardino

**CSUSB ScholarWorks**

---

Theses Digitization Project

John M. Pfau Library

---

1995

## Preparation of a site-specific lymphotoxin- mutant to be used in protein characterization and receptor binding studies

Derek Andrew Knight

Follow this and additional works at: <https://scholarworks.lib.csusb.edu/etd-project>



Part of the [Cell Biology Commons](#)

---

### Recommended Citation

Knight, Derek Andrew, "Preparation of a site-specific lymphotoxin- mutant to be used in protein characterization and receptor binding studies" (1995). *Theses Digitization Project*. 987.  
<https://scholarworks.lib.csusb.edu/etd-project/987>

This Thesis is brought to you for free and open access by the John M. Pfau Library at CSUSB ScholarWorks. It has been accepted for inclusion in Theses Digitization Project by an authorized administrator of CSUSB ScholarWorks. For more information, please contact [scholarworks@csusb.edu](mailto:scholarworks@csusb.edu).

PREPARATION OF A SITE-SPECIFIC LYMPHOTOXIN- $\beta$   
MUTANT TO BE USED IN PROTEIN CHARACTERIZATION AND  
RECEPTOR BINDING STUDIES

---

A Thesis  
Presented to the  
Faculty of  
California State University,  
San Bernardino

---

In Partial Fulfillment  
of the Requirements for the Degree  
Master of Science  
in  
Biology

---

by  
Derek Andrew Knight

June 1995

PREPARATION OF A SITE-SPECIFIC LYMPHOTOXIN- $\beta$   
MUTANT TO BE USED IN PROTEIN CHARACTERIZATION AND  
RECEPTOR BINDING STUDIES

---

A Thesis  
Presented to the  
Faculty of  
California State University,  
San Bernardino

---

by  
Derek Andrew Knight  
June 1995

Approved by:

[Redacted Signature]

Dr. Richard Fehn, Chair, Biology

5/11/95  
Date

[Redacted Signature]

Dr. Lisa Shamansky

[Redacted Signature]

Dr. Ching-Hua Wang

5/12/95

## ABSTRACT

Lymphotoxin (LT) is a cytokine synthesized by cytotoxic T lymphocytes, B cells and natural killer cells. This cytokine is very similar to tumor necrosis factor (TNF) in both structure and in certain functions. LT has been shown to induce cytotoxic, antiviral and growth enhancing activities in a variety of cells (Andrews *et al.*, 1990). LT has also been shown to be essential for the proper development of peripheral lymphoid organs in mice (Togni *et al.*, 1994) and is thought to play a role in the pathogenesis of certain autoimmune diseases (Ruddle *et al.*, 1990), but its role in human development and in the immune response is still poorly understood. One method that will help build upon our knowledge of this cytokine involves placing site-specific mutations in regions of the LT gene thought to be important in receptor binding and in protein structure. One such mutation involves an N-linked glycosylation site present on the membrane bound form of LT (mLT) but absent on the soluble form. By preparing a mutant LT- $\beta$  gene that lacks this glycosylation site, it will be possible to analyze a proposed model for LT structure and ligand receptor interactions.

In this study, such a mutant was prepared using a polymerase chain reaction (PCR) overlap extension

technique to introduce a site-directed single base substitution that destroyed the consensus sequence for N-linked glycosylation, replacing an asparagine residue with a serine residue. It is believed that this substitution results in loss of the N-linked glycosylation site while not significantly altering protein conformation. The presence of the desired mutation was confirmed using dideoxy DNA sequencing analysis and the mutant cDNA cloned into the pcDNA1-amp plasmid. *E. Coli* were transformed with this clone and positive transformants used in the preparation of maxiprep DNA. The DNA obtained was transfected into COS-7 mammalian cells and protein expression analyzed. It was found that neither the mutant or wild-type LT- $\beta$  transfectants produced protein bands when labeled with monoclonal LT- $\beta$  antibodies and immunoprecipitated. These results may indicate that LT- $\beta$  is rapidly degraded when expressed without LT- $\alpha$ .

## Acknowledgements

I would like to thank my wife Barbara and my children, Megan and Christopher for their patience and support during the many long hours this project has required. I would also like to thank the CSUSB faculty members who have offered their encouragement, support and guidance. A special word of thanks to Dr. Lisa Shamansky for her wisdom, encouragement, use of her lab equipment and financial support for reagents, without which this project would have been impossible. Also a word of thanks to everyone at Dr. Carl Ware's lab at UCR, especially Dr. Paul Crowe. And last, but not least, I would like to thank the CSUSB chemistry department for allowing a biology major to work in one of their labs and to the great help obtained from the chemistry stock clerks, Jan Mack and Ken Makino. Thanks to all.

This work was supported by a CSUSB ASI graduate research award.

## Table of Contents

Abstract.....	iii
Acknowledgements.....	v
List of Figures.....	viii
INTRODUCTION.....	1
MATERIALS AND METHODS.....	9
Generation of 5' and 3' PCR fragments containing the desired mutation.....	9
Joining of fragments by PCR Overlap Extension to obtain full length mutant.....	11
Sequence confirmation of mutation.....	11
Cloning of mutant DNA in pcDNA1-amp plasmid.....	13
Maxiprep of pcDNA1-amp/LT- $\beta$ mutant DNA.....	15
COS-7 cell culture.....	16
COS-7 Cell transfection.....	16
Biosynthetic labeling of COS-7 cells.....	17
SDS-Polyacrylimide gel electrophoresis.....	18
RESULTS.....	20
Preparation of 5' and 3' PCR fragments containing the mutation.....	20
Joining of fragments by PCR overlap extension yields full-length mutant.....	20
Sequence confirmation of mutation.....	20
Cloning of mutant DNA in pcDNA1-amp plasmid.....	21
Maxiprep of pcDNA1-amp/LT- $\beta$ mutant DNA.....	21
COS-7 cell transfection, biosynthetic labeling and SDS-PAGE.....	21

DISCUSSION.....36  
BIBLIOGRAPHY.....41



## List of Figures

<u>Figure 1</u>	Schematic diagram of the region of chromosome 6 containing the LT/TNF locus.....	23
<u>Figure 2</u>	A working model for LT biosynthesis and secretion.....	24
<u>Figure 3</u>	Members of the TNF ligand and receptor family.....	25
<u>Figure 4</u>	Proposed model of LT- $\alpha\beta$ complexes.....	26
<u>Figure 5</u>	Molecular model of LT- $\alpha$ /LT- $\beta$ interface.....	27
<u>Figure 6</u>	Primers utilized in PCR and sequencing reactions.....	28
<u>Figure 7</u>	Example of site-directed mutagenesis using overlap extension PCR.....	29
<u>Figure 8</u>	Map of pcDNA1-amp plasmid used as a shuttle vector.....	30
<u>Figure 9</u>	Agarose gel showing fragments made during PCR site-directed mutagenesis procedure.....	31
<u>Figure 10</u>	Sequence confirmation of desired mutation..	32

<u>Figure 11</u>	Restriction digest of clone from pcDNA1-amp.....	33
<u>Figure 12</u>	Autoradiograph of protein immunoprecipitation.....	34
<u>Figure 13</u>	Flow cytometry data showing surface expression of LT- $\alpha/\beta$ on COS-7 cells.....	35

## **Introduction**

The cytokines are a diverse group of proteins that play key roles in the effector phases of both the natural and specific immune responses. Cytokines can be produced by and act upon a wide variety of cell types to regulate immune and inflammatory responses, as well as to influence the synthesis and actions of other cytokines and their receptors. The effects of many cytokines can vary depending on when and where they are expressed and upon the presence of other cytokines. It is this extreme variety of effects that helps give the immune system its flexibility. This pleotropic response ability, although invaluable to the organism, has made the study and understanding of these proteins rather problematic. The mechanisms used by these molecules to elicit such a wide and apparently very specific variety of cellular reactions are still poorly understood. Over the past decade, molecular and recombinant DNA technology has given us some insight into how these molecules interact with each other and with various receptors to cause the wide range of responses seen in the immune response.

One family of cytokines that appears to play a major role in the inflammatory response is the tumor necrosis factor (TNF) family of cytokines. TNF, and the closely related cytokine lymphotoxin (LT), regulate or participate in

all major phases of the cytotoxic T lymphocyte (CTL) lytic pathway (Ware *et al.*, 1990). The importance of these cytokines in the immune response is illustrated by the mechanisms that viruses such as the Pox, Adeno and human immunodeficiency virus (HIV), have developed to defeat or utilize them (Smith *et al.*, 1991; Horton *et al.*, 1991; Gooding, 1992). There is also evidence that these cytokines play a role in certain autoimmune diseases (Ruddle *et al.*, 1990) and in genetic diseases linked to abnormal immune function (Hollenbaugh *et al.*, 1992; Allen *et al.*, 1993; Korthauer *et al.*, 1993; DiSanto *et al.*, 1993; Smith *et al.*, 1993).

TNF is expressed by a wide range of cell types in response to antigens and other inflammatory stimuli (Old, 1985). Although the major source of TNF is the lipopolysaccharide (LPS) activated mononuclear phagocyte, it is also secreted by activated T cells, natural killer (NK) cells and mast cells (Abbas, 1991). Both the soluble and membrane-associated forms of TNF are composed of identical subunits that associate to form a homotrimer. The first two exons of TNF encode a region that contains a 76 amino acid residue that functions as a membrane anchoring domain. This 26 kDa membrane bound form of TNF is the precursor of the secreted form, which is released from the membrane anchoring domain by proteolytic cleavage as a 17 kDa polypeptide. (Kriegler *et al.*, 1988).

LT is a protein secreted by cytotoxic T lymphocytes (CTL), B cells and Natural Killer (NK) cells (Paul and Ruddle, 1988; Ware *et al.*, 1992) as part of the inflammatory and immune response. The predominant species of LT is a 25 kDa glycoprotein in humans, with a cDNA encoding for a 205 amino acid polypeptide. This protein is very closely related to TNF and appears to play a role in the response of CTL against virus infected and malignant cells (Ware *et al.*, 1990). Recently, LT has also been shown to play a role in the proper development of peripheral lymphoid organs in mice (Togni *et al.*, 1994), as well as being implicated in the pathogenesis of certain autoimmune diseases (Ruddle *et al.*, 1990).

The genes for TNF and LT have been cloned and are closely linked in the class III region of the major histocompatibility complex (MHC) on human chromosome 6. They share 56% homology at the nucleotide level, 31% homology at the amino acid level (Andrews *et al.*, 1990) and also have very similar intron-exon arrangements (Spies *et al.*, 1986; Nedwin *et al.*, 1985). The secreted form of LT (LT- $\alpha$ ) and TNF share similar quaternary structures, assembling as homologous trimers (Jones *et al.*, 1989; Eck *et al.*, 1988, Smith and Baglioni, 1987).

Two receptors (TNFR) have been identified with high affinity for TNF and LT- $\alpha$  (Hohmann *et al.*, 1989; Vilcek and Lee, 1991). One, a 60 kDa protein (TNFR<sub>60</sub>) is believed to be

sufficient for initiating cytotoxic function and responses controlled by the nuclear binding protein NF- $\kappa$ B (Schultze *et al.*, 1992). The other is an 80 kDa receptor (TNFR<sub>80</sub>) important in the mediation of T cell responses, the conferring of protective tumor immunity *in vivo* and is the cause of many of the toxic effects caused by TNF administration (Vandenabeele *et al.*, 1992; Van Ostade *et al.*, 1993). Both receptors can be shed following protein kinase C activation, causing down-regulation of the cellular response and giving the organism an additional method by which to modulate the immune reaction to TNF or LT- $\alpha$  (Digel *et al.*, 1992). The binding of TNF to the TNFR occurs at sites within the cleft created at the subunit interface (Zhang *et al.*, 1992), as demonstrated by X-ray crystallography studies of LT- $\alpha$  bound to TNFR<sub>60</sub> (Banner *et al.*, 1993). The signaling mechanisms used by the TNFR to initiate cellular responses are not yet known, but it does appear that multiple signaling pathways are present. The use of these receptors by both LT- $\alpha$  and TNF explains certain similarities in their biologic activity. In fact, the original biological characterizations of TNF and LT showed LT to be a much less potent cytokine *in vitro* and to function as a partial agonist to TNF (Browning and Ribolini, 1989; Andrews *et al.*, 1990). This led to a hypothesis that LT was simply a poorly redundant cytokine, although more recent evidence would seem to indicate that this is not the case.

Like TNF, LT is also seen in a membrane bound form, but

it differs in the method of membrane attachment. Membrane bound LT (mLT) is a heterotrimer containing LT- $\alpha$  subunit(s) associated with the extracellular domain of a 33 kDa protein (p33) (Browning et al., 1991) which also contains transmembrane and cytoplasmic domains. Cloning of the gene encoding p33 led to the discovery that it was homologous to LT- $\alpha$  and TNF and was encoded next to the TNF and LT- $\alpha$  locus on the MHC with similar intron-exon arrangements. These similarities led to the designation of p33 as LT- $\beta$  (Browning et al., 1993) (Figure 1). The form of mLT most frequently observed is a heterotrimer composed of two LT- $\alpha$  monomers associating early in biosynthesis with a single LT- $\beta$  monomer (Androlewicz et al., 1992) (Figure 2). Trimers composed of one LT- $\alpha$  and two LT- $\beta$  subunits have also been observed, but no naturally occurring LT- $\beta$  homotrimers have yet been discovered. Although little is known about the function of mLT, recent evidence implicates mLT in the killing activity of lymphokine activated killer (LAK) cells towards various tumor cell lines (Horiuchi et al., 1994).

The known receptor binding sites on LT- $\alpha$  occur within the cleft formed by the subunit interface (Banner et al., 1993), which implies that up to three TNFR may bind a single LT- $\alpha$  trimer complex (Pennica et al., 1992). This binding of multiple receptors has distinct biological implications, since receptor clustering may lead to a heightened or different cellular response (Engelmann et al., 1990). This

is even more significant in the case of LT and TNF, where different combinations of TNFR<sub>60</sub> and TNFR<sub>80</sub> receptors could potentially lead to a wide variety of responses. This heteromeric clustering has been found to play a role in the pleiotropic cellular responses to TNF (Van Arsdale *et al.*, in preparation) where different cellular responses to TNF occur when heteromeric receptor clustering takes place versus those seen when clustering of only one receptor type occurs. When receptor clustering does not occur, a weaker cellular response is observed. This could explain the original observations that LT binding to the TNFR led to a weaker cellular response than that caused by TNF if the predominant form of LT present was mLT, a form that could theoretically bind at most one TNFR at the  $\alpha$ - $\alpha$  subunit interface and hence not lead to receptor clustering. A receptor specific for the LT- $\beta$  subunit interface has been discovered and has been termed LT- $\beta$ R (Crowe *et al.*, 1994). Like the TNFR, this receptor is a member of the TNF/Nerve Growth Factor (NGF) family of receptors (Figure 3), a family characterized by strong homology in the cysteine rich N-terminal portion of the receptors (Goodwin *et al.*, 1991). There is also evidence to suggest that a receptor specific for the  $\alpha$ - $\beta$  interface does exist (Crowe, personal communication), as evidenced by mLT binding even in the presence of anti-LT $\beta$ R and anti-TNFR antibodies. This receptor has not yet been isolated and any cellular signals generated by it are still unknown. These



discoveries implicate a wider role for LT in both the immune response and in development than was previously thought and demonstrate the importance of learning more about LT and the mechanisms it utilizes by studying it at the molecular level.

Current models for the structure of mLT may lead to a better understanding not only of its true function, but also of the immune system in general. A model has been proposed (Ware, unpublished data) in which the binding of the LT ligand with its receptor is dependent upon the type of subunit interface present (Figure 4). In this model, LT can exist as one of four potential trimers. LT- $\alpha$ , the secreted form of LT composed of three identical LT- $\alpha$  subunits ( $\alpha_3$ ) has already been structurally well characterized. Although little is yet known about the 3-D structure of LT- $\beta$ , its sequence similarity with LT- $\alpha$  and TNF allow for some general assumptions to be made in generating this model. The three other potential structures each contain LT- $\beta$  subunits as shown in figure 4 ( $\alpha_2\beta_1$ ,  $\alpha_1\beta_2$ ,  $\beta_3$ ). As the number of LT- $\beta$  subunits increases, the number of TNFR binding sites decreases and the number of LT- $\beta$ R sites increases. Binding of the TNFR has been shown to occur within the  $\alpha$ - $\alpha$  subunit cleft and it is theorized that LT- $\beta$ R binds within the  $\beta$ - $\beta$  cleft. These changes in receptor binding specificity would explain the variety of cellular responses seen upon LT exposure and would theoretically allow the organism to modulate its immune response by altering the predominant species of LT or

receptor present.

One major difference between LT- $\alpha$  and LT- $\beta$  subunits is the presence of an N-linked glycosylation site on LT- $\beta$  located very near the region where TNFR binding occurs in LT- $\alpha$  (Figure 5). Based upon predictions of the 3-D conformation of the  $\alpha$ - $\beta$  subunit interface, TNFR binding within this cleft may be blocked by the carbohydrate attached to the N-linked glycosylation site. If this is the case, this would be a novel and previously unseen method by which nature has regulated receptor binding by the presence or absence of a carbohydrate.

In this study, LT- $\beta$  was mutated to remove this N-linked glycosylation site so that studies could be carried out to examine the role of this site in LT function. The preparation of a mutant LT- $\beta$  gene lacking this site will allow for further analysis of the role the sugar residue normally present plays (if any) in sterically hindering the effective binding of the TNFR bound by LT- $\alpha$ , which would potentially lead to a different cellular response. It is also possible that this sugar residue may play a role in trimer construction by preventing three LT- $\beta$  subunits from interacting to form a trimer. This would explain the lack of finding such a homotrimer in nature. By creating this mutant gene, it will be possible to look at these and other relationships between this residue and LT receptor binding specificity and trimer formation, as well as cytotoxicity.

## MATERIALS AND METHODS

**Generation of 5' and 3' PCR fragments containing the desired mutation.** The amino acid consensus sequence for N-linked glycosylation is asparagine (N), any amino acid (X), serine (S)/threonine (T) (NXS/T). The N residue of LT- $\beta$  was substituted through the use of two pairs of PCR primers (Figure 6). In one reaction, a 710 base pair (bp) fragment which included the LT- $\beta$  sequence encoding amino acid residues 1-225 was PCR amplified with the external 5' primer (5'pCDM8/LT- $\beta$ ) and an internal primer (3'LT- $\beta$ N-S02) containing sequences encoding S instead of N in the middle region of the primer. In a second reaction a 3' external primer (3'LT- $\beta$ /Not1) and an internal primer (5'LT- $\beta$ N-S02) were used to amplify LT- $\beta$  amino acid residues 219 through the stop codon and 3' untranslated region (UTR) to yield a 107 bp fragment. This internal primer again contained sequences that replaced the N with an S and was complimentary to the other internal primer. Both sets of primers were obtained from Cruachem and diluted to a concentration of 50  $\mu$ M with distilled water (dH<sub>2</sub>O). Reaction conditions for both fragments were identical, except the 5' reaction mixture contained 10% dimethylsulfoxide (DMSO). Reactions were carried out in 0.6 ml thin walled microfuge tubes (Midwest Scientific) in a thermal cycler (MJ Research Minicycler). Each fragment was

generated using 0.5  $\mu$ l (338 ng) of wild type LT- $\beta$  cloned in the pCDM8 plasmid as a template. This template was a generous gift from Dr. J. Browning (Biogen, Inc. Cambridge, MA). The reaction also included 4  $\mu$ l (200  $\mu$ M each) deoxynucleotide triphosphate (dNTP) mix, 6  $\mu$ l (1.5 mM)  $MgCl_2$  and 10  $\mu$ l 10X PCR buffer (Perkin Elmer). The 5' fragment also had 10  $\mu$ l of DMSO added to the tube. One microliter (0.2  $\mu$ M) of each of the appropriate 5' and 3' primers was added and the reaction vessel brought up to a volume of 99.5  $\mu$ l using  $dH_2O$ . The tubes were placed in the thermal cycler and the temperature increased to 97°C for 1 minute, then 0.5  $\mu$ l (2.5 Units) of DNA Ampli-Taq Polymerase (Perkin Elmer) was added to each tube. The samples were then subjected to 30 cycles of denaturation (95°C/1 minute), annealing (58°C/1 minute) and extension (72°C/45 seconds). This was followed by a 4 minute 72°C extension and the reactions were then cooled to 4°C. The PCR products were run on a 3% Nu-Sieve agarose (FMC) minigel in tris-acetate-EDTA (TAE) buffer (0.04M tris, 0.001M EDTA) for one hour at 100 volts and the desired bands excised and purified using FMC Spin Bind columns. The DNA products were eluted from the columns using 50  $\mu$ l tris-EDTA (TE) buffer (10 mM tris·Cl, 1 mM EDTA), pH 8.0, and stored at -20°C.

**Joining of fragments by PCR Overlap Extension to obtain full length mutant.** The 5' and 3' fragments were combined following gel purification to yield the full length mutant DNA via an overlap extension technique (Figure 7). Ten microliters DMSO, 10  $\mu$ l 10X PCR buffer, 6  $\mu$ l (1.5 mM)  $MgCl_2$ , 4  $\mu$ l (200  $\mu$ M each) dNTP's, and 200 ng of each of the 5' and 3' fragments obtained above were mixed and the volume brought up to 97.5  $\mu$ l with  $dH_2O$ . This mixture was denatured at 95°C for 1 minute, and 0.5 ml (2.5 units) Taq polymerase added. Five cycles were then carried out using a 95°C/1 minute denaturation, 45°C/2 minute annealing and 72°C/3 minute extension step. Following this, 1  $\mu$ l (0.2  $\mu$ M) of the 5'pCDM8/LT- $\beta$ II primer and 1  $\mu$ l (0.2  $\mu$ M) of the 3'LT- $\beta$ /Not 1 primer were added and 25 additional cycles completed with a modification in the annealing step to 50°C/2 minutes. A 72°C/10 minute final extension step was performed and the samples cooled to 4°C. Sixty microliters of this reaction was run through the FMC Spin Bind PCR Product Purification column and the product run on a 3% Nu-Sieve agarose gel.

**Sequence confirmation of mutation.** DNA sequence confirmation of the desired mutation was performed using a Sequenase PCR Product Sequencing Kit (United States Biochemical). Three microliters (60 ng) of the mutated DNA was used as a template in each sequencing reaction. Sequences were run from both the 5' and 3' ends using the 3'

outside primer and a 5' primer (5' Seq) (Figure 6) that codes for an 18 base sequence located 100 bp upstream from the mutation. First, an annealing mix was prepared using the template and 1  $\mu$ l (0.2  $\mu$ M) of the appropriate primer. The volume of this mix was brought up to 10  $\mu$ l with dH<sub>2</sub>O. The mixture was denatured by heating in the thermal cycler at 100°C for 3 minutes and then rapidly cooled in an ice-water bath for 5 minutes and kept cool on ice. While cooling, 2.5  $\mu$ l of each termination mix (A, C, G and T) were placed in individual microfuge tubes. These tubes were prewarmed to 37°C in a water bath. A labeling mix was prepared by making a 1:5 dilution of the labeling mix supplied with the kit in dH<sub>2</sub>O. To the ice-cold annealing mix the following was added: 2  $\mu$ l reaction buffer, 1  $\mu$ l 0.1M dithiothreitol (DTT), 2  $\mu$ l 1:5 diluted labeling mix, 0.5  $\mu$ l [<sup>35</sup>S]dATP (Amersham, 1000 Ci/mmol specific activity) and 2  $\mu$ l (3.2 units) Sequenase DNA Polymerase. This mixture was allowed to incubate at room temperature for 5 minutes and then 3.5  $\mu$ l was added to each of the four termination tubes and incubated for 5 minutes at 37°C. The reactions were then stopped using 4  $\mu$ l of stop solution and the samples briefly heated to 75°C immediately prior to loading onto the gel. The samples were run on a 6% polyacrylimide gel in an IBI Base Runner 100 electrophoresis apparatus. Samples were run at 50 watts constant power for 6 hours (three sets of each sample loaded at two hour intervals) maintaining gel temperature at approximately 50°C.

Following the run, the gel was rinsed in a 5% Acetic Acid/5% Methanol bath for 15 minutes and then transferred to Whatman 3MM filter paper and dried on a Labconco gel drier for 1 hour at 75°C, exposed to Fuji X-Ray film for 72 hours then developed and the sequence analyzed.

**Cloning of mutant DNA in pcDNA1-amp plasmid.** Once the mutant sequence was confirmed, the DNA was ligated into a pcDNA1-amp plasmid (Invitrogen) for future amplification and analysis. The pcDNA1-amp plasmid (Figure 7) is an approximately 4.8 kb high copy number shuttle vector expressed in both prokaryotic and eukaryotic systems that confers ampicillin resistance in *E. Coli*. First, 500 ng of the desired DNA was digested with the restriction enzymes Not-1 (recognition sequence GC<sup>^</sup>GGCCGC) and Hind III (recognition sequence A<sup>^</sup>AGCTT) (7 Units each, GIBCO) at 37°C for 6 hours and purified using the Spin Bind PCR Purification System to remove the end fragments and unwanted enzymes. One microgram of pcDNA1-amp was also digested in this manner and gel purified to remove the polylinker and to prepare cohesive ends for ligation. Several ligation reactions were then set up as follows. As a control, a 0:1 insert to vector (vector only) ligation was performed using 100 ng cut pcDNA1-amp, 2 µl 10X ligase buffer and 0.5 µl (2.5 Units) T4 DNA ligase (GIBCO). The reaction volume was brought up to 20 µl using dH<sub>2</sub>O. 2:1 and 3:1 insert to vector ligations were also

prepared as above. The reactions were allowed to continue for 16 hours at 16°C and then were placed on ice. Twenty microliters of GIBCO JM 109 frozen supercompetent cells were placed in prechilled Falcon 2059 tubes and 1 µl of a 1:5 dilution of each ligation mix in dH<sub>2</sub>O was placed into the appropriate tubes. This mixture was kept on ice for 30 minutes, heat shocked at 42°C for 45 seconds and placed back on ice for 2 minutes, then 980 µl of SOC medium prewarmed to 37°C was added to each tube. The tubes were incubated at 37°C with shaking at 225 RPM for 1 hour, then 200 µl of each mix was plated on Luria Broth (LB) plates supplemented with ampicillin at a concentration of 100 µg/ml (amp 100) and incubated overnight at 37°C. Single colonies were selected and grown in 2 ml LB/amp 100 at 37°C overnight. Minipreps were performed on 1.5 ml of each culture using the Promega Magic Miniprep kit. First the cultures were pelleted in a microfuge at 14,000 rpm for 2 minutes and the cells resuspended in 100 µl of Promega resuspension buffer, then 1 ml of Promega binding resin was added and the solution mixed gently. This solution was then placed in a 3 ml syringe and gently pushed through a Promega Magic Miniprep column, followed by a wash with 2 ml of 80% isopropanol wash buffer and elution with 50 µl TE prewarmed to 65°C. The remaining 0.5 ml of culture was saved as stock for future cultures by adding 150 µl of 80% glycerol and storing at -20°C. The DNA obtained was digested with Not-1 and Hind III and run on a 1%



agarose gel to confirm the presence of the desired 760 bp fragment.

**Maxiprep of pcDNA1-amp/LT- $\beta$  Mutant DNA.** A culture was prepared using 100  $\mu$ l of the stored 0.5 ml *E. Coli* culture which had tested positive for the mutant insert previously in the miniprep and 200 ml of LB/amp 100. This culture was grown overnight at 37°C. To obtain the desired plasmid DNA the culture was centrifuged at 12,000xg for 15 minutes at 4°C and the supernatant discarded. The pellet was dissolved in 10 ml of resuspension buffer containing 100  $\mu$ g/ml RNase A, 0.1 mM Tris/HCl and 10 mM EDTA, pH 8.0. Once dissolved, 10 ml of lysis buffer containing 200 mM NaOH and 1% SDS was added and then the tube was inverted 5 times and incubated at room temperature for 5 minutes. After incubation, 10 ml of lysis neutralization buffer containing 3.0 M potassium acetate (KAc), pH 5.5 was then added, the tube inverted several times and then put on ice for 20 minutes. The tube was mixed again and centrifuged at 30,000xg for 30 minutes at 4°C. While the mixture was centrifuging, 10 ml of column equilibration buffer containing 750 mM NaCl, 50 mM MOPS (3-[N-Morpholino]propanesulfonic acid), 15% ethanol and 0.15% Triton X-100 at a pH of 7.0 was added to a QIAGEN tip-500 column and allowed to enter by gravity flow. This was followed by the supernatant obtained from the centrifuged cell lysate. Once the lysate had flowed through the column,

2 washes were performed using 30 ml each of wash buffer containing 1.0 M NaCl, 50 mM MOPS and 15% ethanol at a pH of 7.0. The column bound DNA was then eluted using 15 ml of elution buffer containing 1.25 M NaCl, 50 mM Tris/HCl and 15% ethanol at a pH of 8.5. To the eluate, 0.7 volumes of room temperature isopropanol was added and the mixture centrifuged for 30 minutes at 15,000xg at 4°C. The pellet was then washed with 15 ml ice-cold 70% ethanol and centrifuged again. The DNA pellet was allowed to dry for 10 minutes and was then redissolved in 0.5 ml TE pH 8.0. The DNA obtained was analyzed on a 1% agarose gel.

**COS-7 cell culture.** COS-7 mammalian (monkey kidney) cells were maintained in Dulbecco's Modified Eagles Medium (DMEM) supplemented with 10% fetal calf serum, 2 mM glutamine, penicillin and streptomycin (100 µg/ml each) in 10% CO<sub>2</sub>/90% ambient atmosphere at 37°C. The cells were passaged every 3-4 days upon reaching approximately 80-90% confluence.

**COS-7 cell transfection.** 2.5 x 10<sup>5</sup> cells were plated into 60 mm culture dishes the day prior to transfection and grown in DMEM as above. The cells were rinsed twice with 5 ml warm phosphate buffered saline (PBS) and then with 5 ml of serum free DMEM. A DNA/Liposome solution was prepared containing 1 µg DNA, 2 ml serum free DMEM and 10 µl LipofectACE (GIBCO) in a 5 ml polystyrene tube. Tubes were prepared containing

LT- $\alpha$ , LT- $\beta$ , LT- $\beta$  mutant and control vector (Cav.Not) DNA. The solution from each tube was added to a plate and the plates incubated at 37°C in 10% CO<sub>2</sub>/90% ambient atmosphere for 5 hours. 2 ml of DMEM supplemented with 20% fetal calf serum was then added and the plates incubated at 37°C overnight. The media was then replaced with 3 ml of DMEM containing 10% fetal calf serum and incubated an additional 48 hours.

**Biosynthetic labeling of COS-7 cells.** The monolayer of transfected cells was washed twice with warm PBS. To each dish, 1 ml of cys/met-free DMEM containing 10% dialyzed fetal calf serum and glutamine was added and the dish incubated 5 minutes at room temperature. A 150  $\mu$ Ci/ml <sup>35</sup>S-cys/met label (ICN Trans label ~10  $\mu$ Ci/ml) was then added and the plates incubated at 37°C for 3 hours with occasional rocking. The supernatant was then removed and transferred to a microfuge tube. The monolayers were lysed with 1 ml/dish ice-cold lysis buffer (20 mM Tris-HCl, pH 8.0, 150 mM NaCl, 2% Nonidet P-40 (NP-40), 1 mM EDTA, 40 mM iodoacetamide and 2mM phenylmethylsulfonyl flouride) for 10 minutes at 4°C. The lysates were then transferred to a microfuge tube and the tubes centrifuges at 13,000 rpm for 10 minutes at 4°C. Each sample was then transferred to a fresh microfuge tube for immunoprecipitation. Each tube was precleared by adding 1  $\mu$ g of mouse IgG and 40  $\mu$ l protein G-Sepharose (GammaBind G-Sepharose, Pharmacia). The tubes were capped tightly and

rocked 1 hour at 4°C, then centrifuged briefly to pellet the protein G beads and the supernatant was then removed and placed in a new tube. A mixture of 1 µg each of three monoclonal anti-LT-β antibodies (B27, B9 and C37) (BIOGEN) was added along with 40 µl/tube of protein G-Sepharose to the tubes containing the Cav.Not control, LT-β and the LT-β mutant. One microgram of an anti-LT-α monoclonal antibody (NC2) (Biogen) along with the protein G beads was added to the LT-α transfection control tube. The tubes were capped tightly and rocked 1 hour at 4°C, then centrifuged briefly to pellet the protein G beads. The samples were aspirated and the beads washed three times with wash buffer containing 20 mM Tris (Ph 8.0), 0.5% NP-40, 150 mM NaCl, 0.5% deoxycholate and 0.05% sodium dodecyl sulfate (SDS) and once with PBS-azide (N<sub>3</sub>) then resuspended in 50 µl 2x SDS-PAGE sample buffer containing 100 mM Tris-Cl (pH 6.8), 200 mM dithiothreitol, 4% SDS, 0.2% bromophenol blue, 20% glycerol plus 4% 2-mercaptoethanol and heated for 5 minutes at 100°C.

#### **SDS-Polyacrylimide gel electrophoresis (SDS-PAGE).**

The samples were then loaded on a 12% SDS-polyacrylamide gel and run overnight at 10 mA constant current to separate proteins. The gel was then soaked for 30 minutes in 1 M sodium salicylate (fluor) and transferred to Whatman 3MM filter paper and dried at 75°C for 1 hour. The dried gel was

exposed to X-Omat AR film (Eastman Kodak) and a Cronex intensifying screen (Du Pont) for 24 hours at  $-70^{\circ}\text{C}$  and developed.

## RESULTS

**Preparation of 5' and 3' PCR fragments containing the mutation.** Through the use of the two sets of primers discussed previously, the expected fragments were obtained. Agarose gel electrophoresis of the PCR products showed bands at approximately 710 bp and 107 bp respectively (Figure 9). The optimization of reagent concentrations and cycling parameters resulted in the amplification of only the desired fragments while avoiding the generation of non-specific and unwanted fragments.

**Joining of fragments by PCR Overlap Extension yields full-length mutant.** Application of the overlap extension technique using the two fragments generated above yielded a 760 bp fragment (Figure 9) which represents the full length mutated LT- $\beta$  cDNA. The PCR reaction yielded approximately 1  $\mu$ g of DNA. Optimization of reagent and cycling parameters eliminated non-specific fragments.

**Sequence confirmation of mutation.** The use of the Sequenase PCR Product Sequencing kit allowed for rapid sequence analysis of the PCR product. Both the 5' and 3' DNA strands contained the desired mutation (figure 10) and no other random mutations were observed within 100 bp either side of the site-directed mutation on either strand.

**Cloning of mutant DNA in pcDNA1-amp plasmid.**

Restriction digests of the vector and the PCR product resulted in the creation of compatible cohesive ends that allowed for specific ligation of the insert in the proper orientation into the vector while avoiding religation of vector alone. No transformants were noted in the vector only control plate, while the 2:1 and 3:1 plates both contained 20 transformed colonies. Miniprep DNA from these colonies were analyzed by restriction digests and all analyzed colonies contained the expected 760 bp insert (figure 11).

**Maxiprep of pcDNA1-amp/LT- $\beta$  mutant DNA.** A culture that tested positive for the insert in the miniprep was used to grow a large culture for the maxiprep. Approximately 250  $\mu$ g of pcDNA1-amp/LT- $\beta$  mutant DNA was obtained from a 200 ml culture.

**COS-7 cell transfection, biosynthetic labeling and SDS-PAGE.** Immunoprecipitation of cell lysates using monoclonal antibodies specific for LT- $\alpha$  or LT- $\beta$  confirmed that COS-7 cells were successfully transfected. The autoradiograph of the labeled precipitates showed a band at 26 kDa representing the LT- $\alpha$  sample and indicates a successful transfection. However, no bands were evident in samples transfected with either LT- $\beta$  or mutant LT- $\beta$ . Precipitation of these samples was attempted using three

different monoclonal antibodies to ensure the epitope had not been lost during the mutagenesis, however none of the monoclonal antibodies precipitated confirming proteins in either LT- $\beta$  sample.



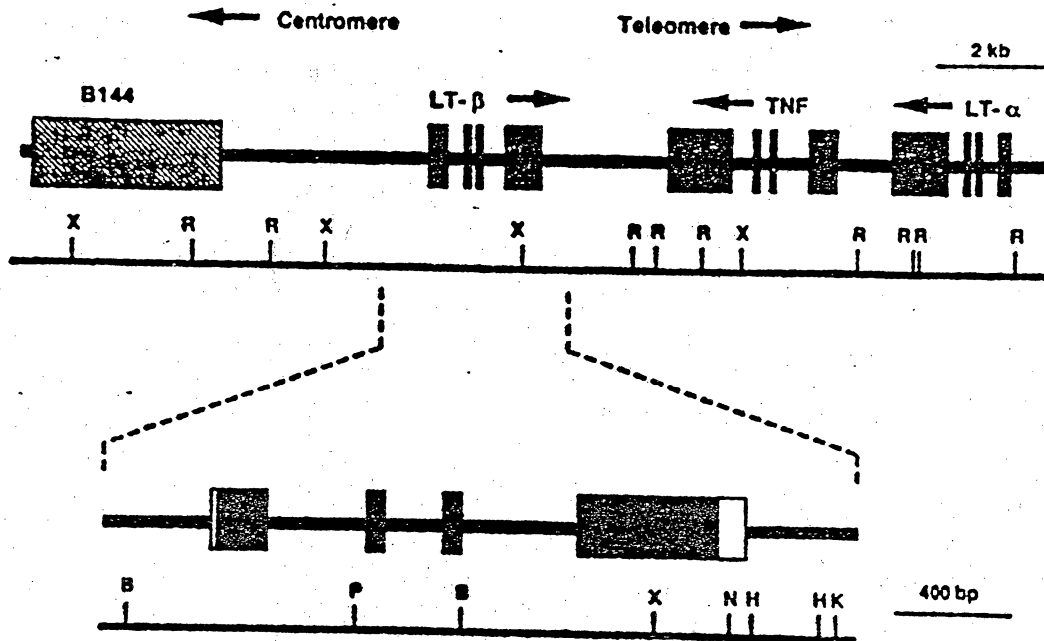

Figure 1. Schematic diagram of the region of chromosome 6 containing the LT/TNF locus. TNF, LT- $\alpha$  and LT- $\beta$  are linked within 10 kb in the MHC on human chromosome 6. The exon-intron arrangements for each gene are similar. LT- $\beta$  is coded for in an opposite direction from TNF and LT- $\alpha$ . Restriction map shows sites for EcoRI (E), XhoI (X), HindIII (H), BglII (B), KpnI (k), PstI (P) and NcoI (N). (From Browning et al., 1993)

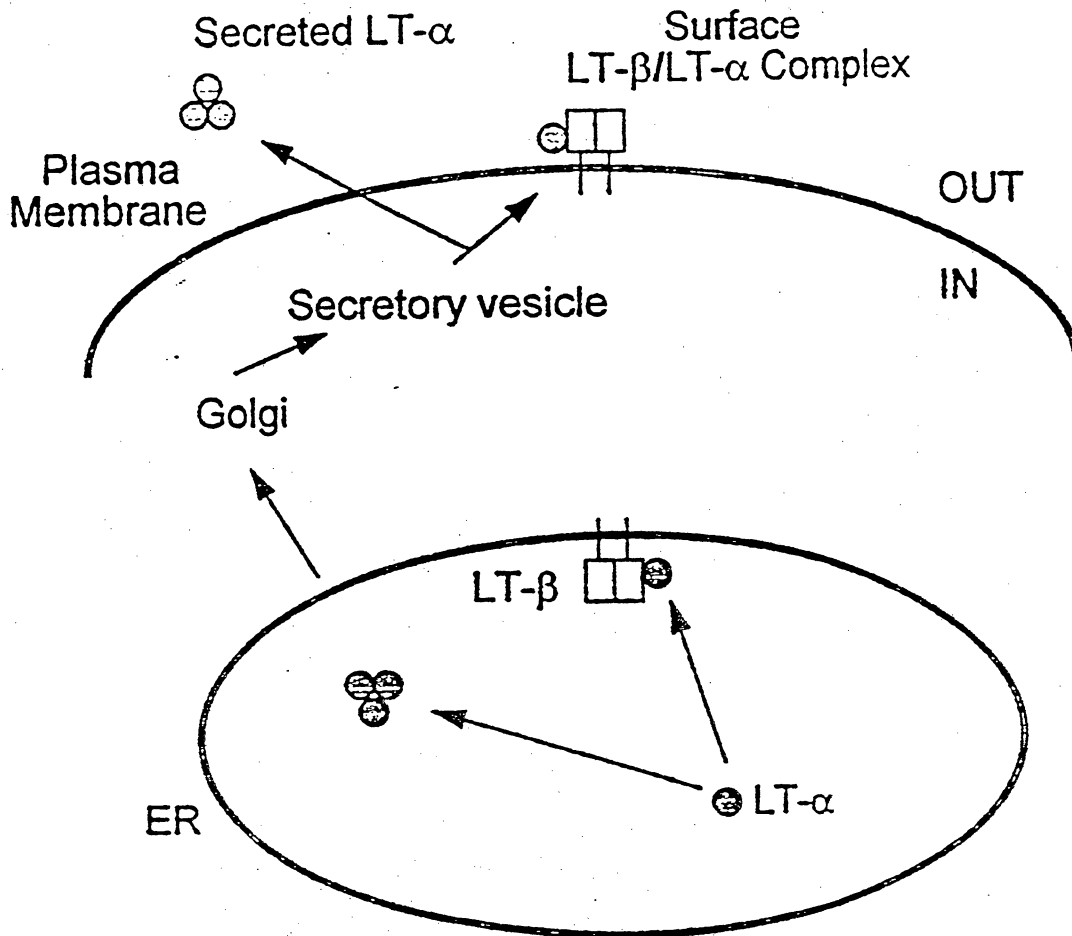

Figure 2. **A working model for LT biosynthesis and secretion.** Newly formed LT- $\alpha$  and LT- $\beta$  monomers can associate within the lumen of the endoplasmic reticulum to form trimers composed of  $\alpha_3$ ,  $\alpha_2\beta_1$  or  $\alpha_1\beta_3$  subunits. These subunits are then processed within the Golgi and transported to the cell surface for expression as mLT ( $\alpha_2\beta_1$  or  $\alpha_1\beta_2$ ) or secreted LT ( $\alpha_3$ ). (Adapted from Androlewicz *et al.*, 1992)

### TNF Ligand Family

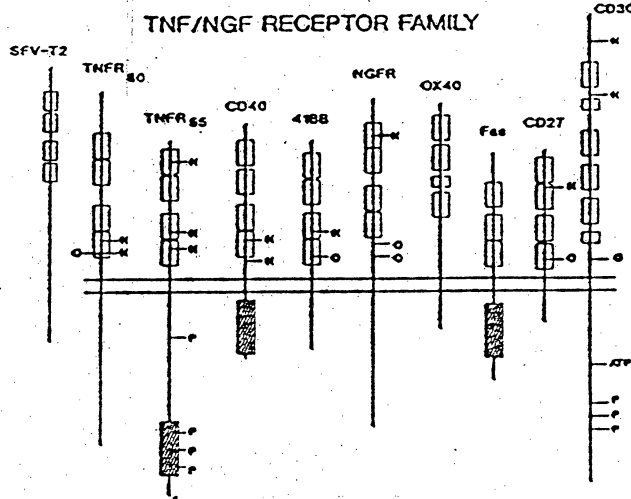
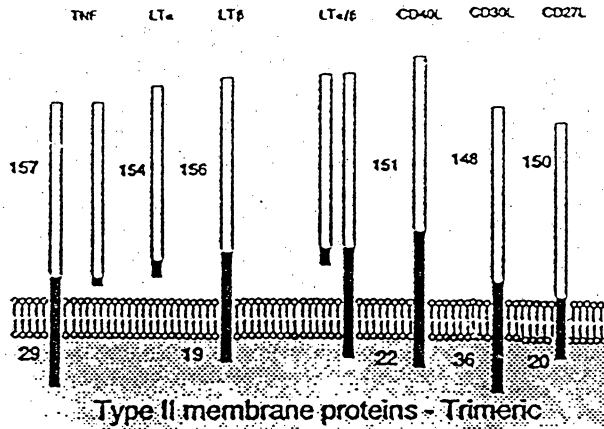

Figure 3. **Members of the TNF ligand and receptor family.** For the ligands, an open box indicates the region of homology in the extracellular domain where the receptor binding sites are located, while the filled boxes indicate the cytoplasmic, transmembrane and extracellular stalk regions. The number of residues in each region are indicated. The receptor cys-rich repeat homology regions are shown as open boxes. Stripped boxes in the cytoplasmic region indicate homology. N or O indicate likely sites of glycosylation and P represents sites of phosphorylation (Ware, unpublished data).

## LT- $\alpha\beta$ Complexes

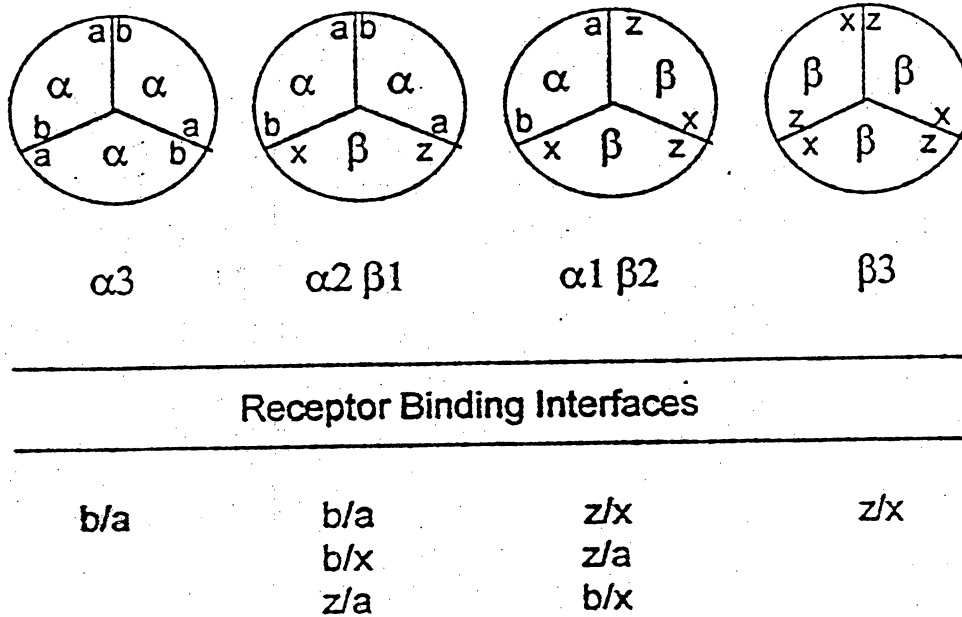

Figure 4. **Proposed model of LT- $\alpha\beta$  complexes.** The four potential trimers that are proposed for LT and the possible receptor binding interfaces for each. The  $\alpha_3$  trimer could bind up to three TNFR which are specific for the  $\alpha$ - $\alpha$  cleft. The  $\alpha_2\beta_1$  trimer could potentially bind only one TNFR and one LT- $\beta$ R, which are specific for the  $\beta$ - $\beta$  cleft. The  $\alpha_1\beta_2$  could not bind a TNFR but could bind up to two LT- $\beta$ R. The  $\beta_3$ , which has not been observed to occur in nature, could bind three LT- $\beta$ R. The cleft formed at  $\alpha$ - $\beta$  subunit interfaces is thought to bind an as yet unidentified receptor (Ware, unpublished data).

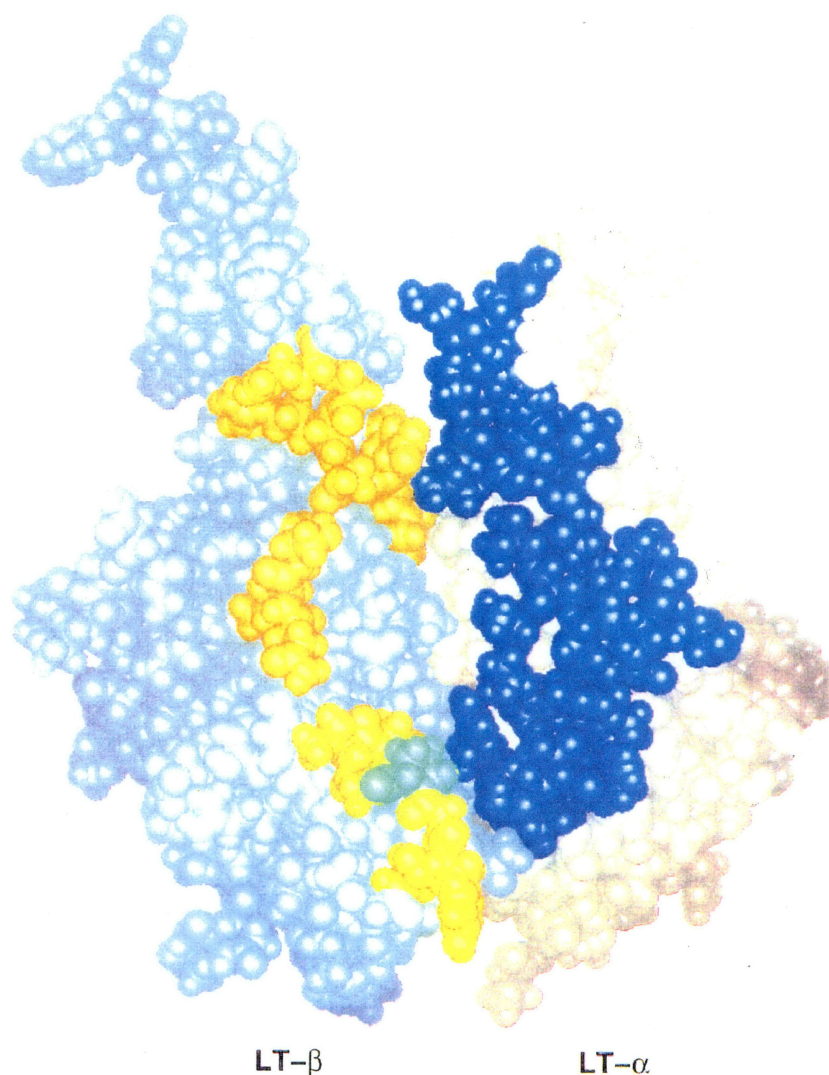

Figure 5. **Molecular model of LT- $\alpha$ /LT- $\beta$  interface.** The LT- $\beta$  subunit contains transmembrane and cytoplasmic domains not present on the LT- $\alpha$  subunit. LT- $\beta$  also contains an N-linked glycosylation site very near the proposed binding region for the TNFR in the interface cleft. It is possible that this N-linked glycosylation site positions a carbohydrate that sterically blocks TNFR binding to mLT. The dark blue and yellow areas indicate regions of homology and the green area is a conserved proline thought to function in subunit association (Ware, unpublished data).

**Outside Primers:**

**5' pCDM8/LT- $\beta$**

5' CGACTCACTATAGGGAGACC3' Melting Temp. 54°C

**3' LT- $\beta$ /Not-1**

5' CGCGGCCGCACTCGCACCACGC3' Melting Temp. 80°C

**Inside Primers:**

**5' LT- $\beta$ N-S01**

5' GTGACTGATGCTGACGTACAC3' Melting Temp. 64°C

**3' LT- $\beta$ N-S01**

5' GTGTACGTCAGCATCAGTCAC3' Melting Temp. 64°C

**5' Sequencing Primer:**

**5' LT- $\beta$ /Seq**

5' GAGACGGTGACTCCAGTG3' Melting Temp. 58°C

**Figure 6. Primers utilized in PCR and sequencing reactions.** Primers used in the PCR reactions include the outside primers, 5'pCDM8/LT- $\beta$  and 3'LT- $\beta$ /Not-1. These primers allow for amplification of the entire LT- $\beta$  gene and the 3'LT- $\beta$ /Not-1 also inserts a Not-1 site in the 3' untranslated region. Inside primers include 5'LT- $\beta$ N-S01 and 3'LT- $\beta$ N-S02. These primers were used to insert the desired single base substitution (underlined) into the two fragments generated for use in the overlap extension procedure, changing the sequence to code for serine instead of asparagine. 5'LT- $\beta$ /Seq was used to generate the 5' strand used in sequencing, this primer annealed approximately 100 bp upstream from the mutation site. A 3' strand was also generated for sequencing using the 3'LT- $\beta$ /Not-1 primer.

### Creation of LT- $\beta$ Mutant Overlap Extension PCR

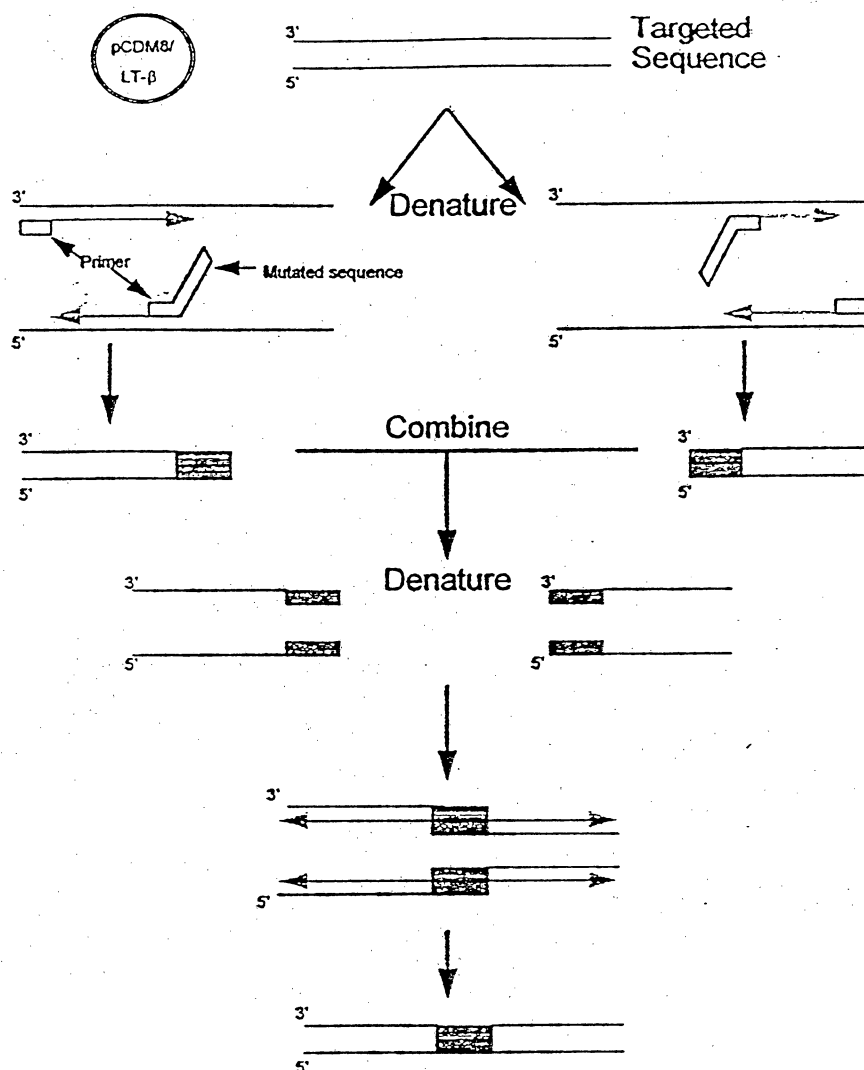

Figure 7. **Example of site-directed mutagenesis using overlap extension PCR.** Specific base changes can be made using the overlap extension technique. Two separate PCR fragments are prepared, utilizing 5' and 3' non-mutated outside primers and complimentary internal primers that contain the desired base changes. These two fragments are amplified in separate PCR procedures, then the purified products combined, denatured and annealed and extended to form a full length template containing the mutation. The 5' and 3' outside primers are then added and another full PCR cycle run to amplify a full length mutant sequence.

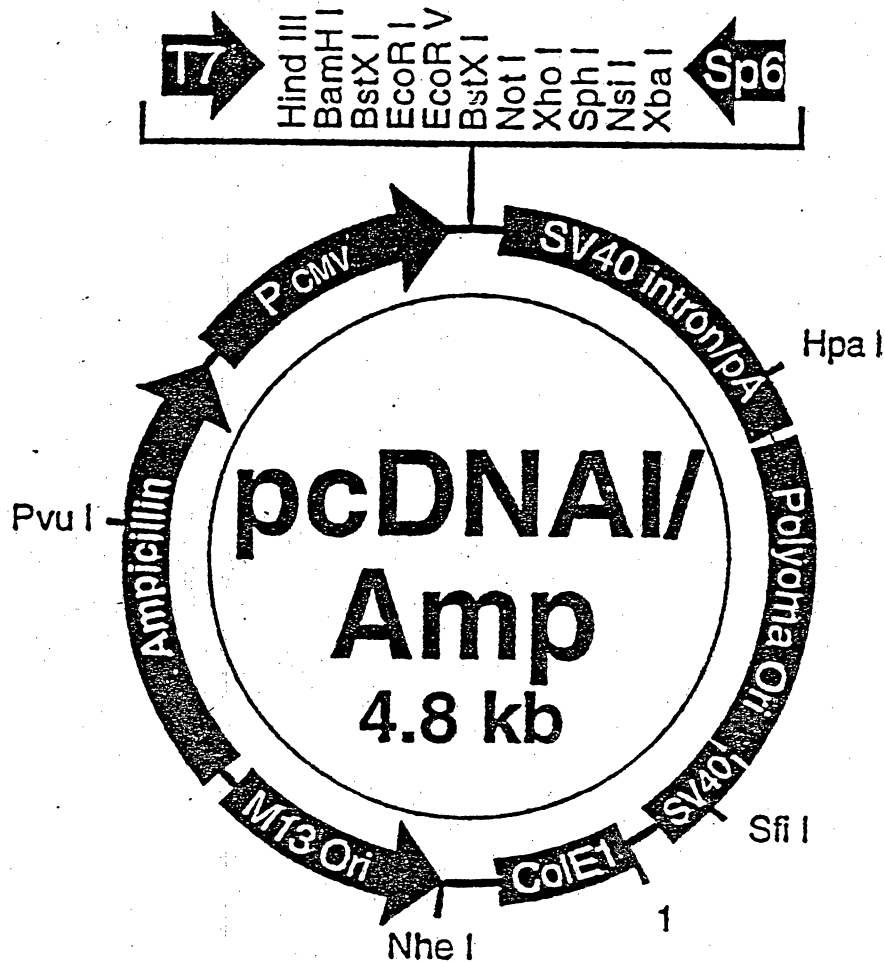

Figure 8. Map of the pcDNA1-amp plasmid used as a shuttle vector. The pcDNA1/Amp plasmid contains a strong promoter for eukaryotic expression, a ColE1 sequence for high copy replication in *E. coli* and ampicillin resistance in *E. coli* for positive selection (Map supplied by Invitrogen).



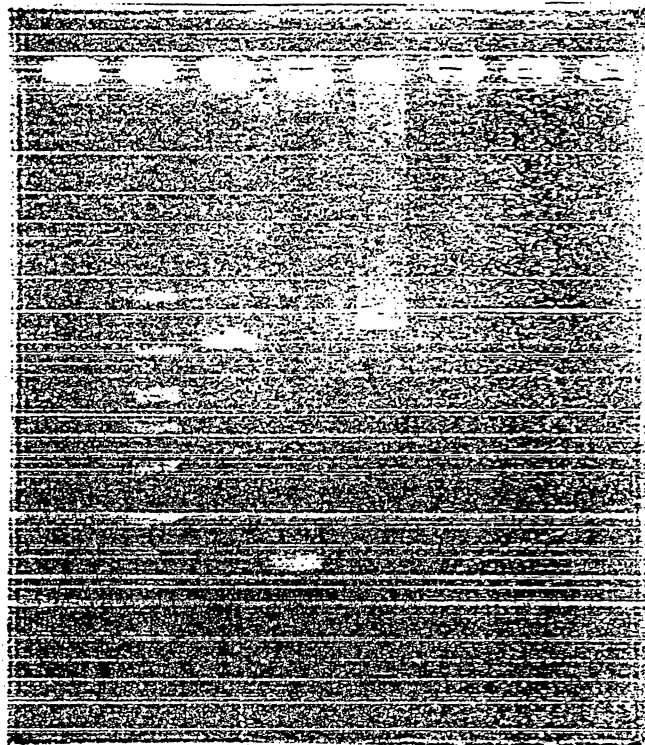
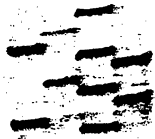

Figure 9. **Agarose gel showing fragments made during PCR site directed mutagenesis procedure.** Lane 1 contains molecular weight markers (BioMarker Low). Bands are at 1000, 700, 525, 500, 400, 300, 200, 100 and 50 bp. Lane 2 shows the 5' fragment at approximately 710 bp. Lane 3 contains the 3' fragment of approximately 107 bp. Lane 4 shows the overlap extension product obtained by combining the fragments from lanes 2 and 3. This fragment represents the full length mutated LT- $\beta$  gene of 760 bp and contains restriction enzyme sites for Hind III at the 5' end and Not-1 at the 3' end.

A C G T



3' sequence

**Mutated Sequence:** 5' CGTCAGCATC 3'  
3' GCAGTCGTAG 5'

Figure 10. **Sequence confirmation of desired mutation.** The presence of the desired sequence was confirmed using dideoxy-DNA sequencing as seen on the 3' sequence shown in this autoradiograph. The site-specific mutation was the single base substitution underlined and in bold. This substitution results in an amino acid change from asparagine to serine, leading to a loss of the N-linked glycosylation site in the protein product.

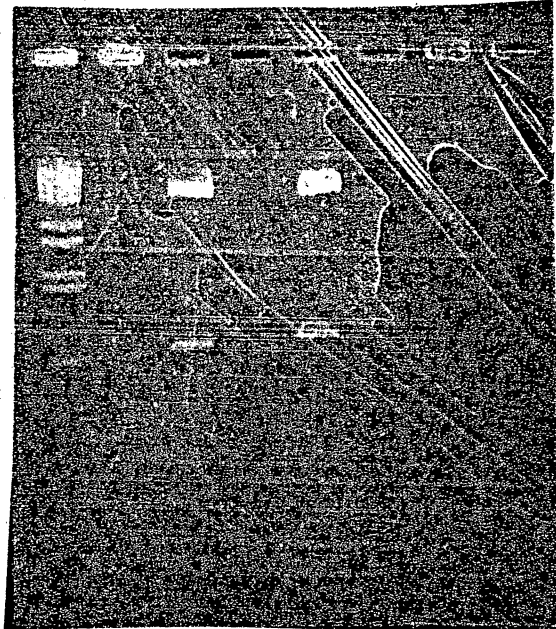

Figure 11. **Restriction digest of clone from pcDNA-amp.** Following transfection, DNA minipreps were performed to confirm insertion of the cloned DNA. Restriction digests of the miniprep DNA with Not-1 and Hind III yielded a 760 bp fragment, indicating the mutated gene has been successfully inserted into the pcDNA1-amp plasmid. The left lane contains known molecular weight markers of Lambda DNA cut with the restriction enzyme Bst EII.

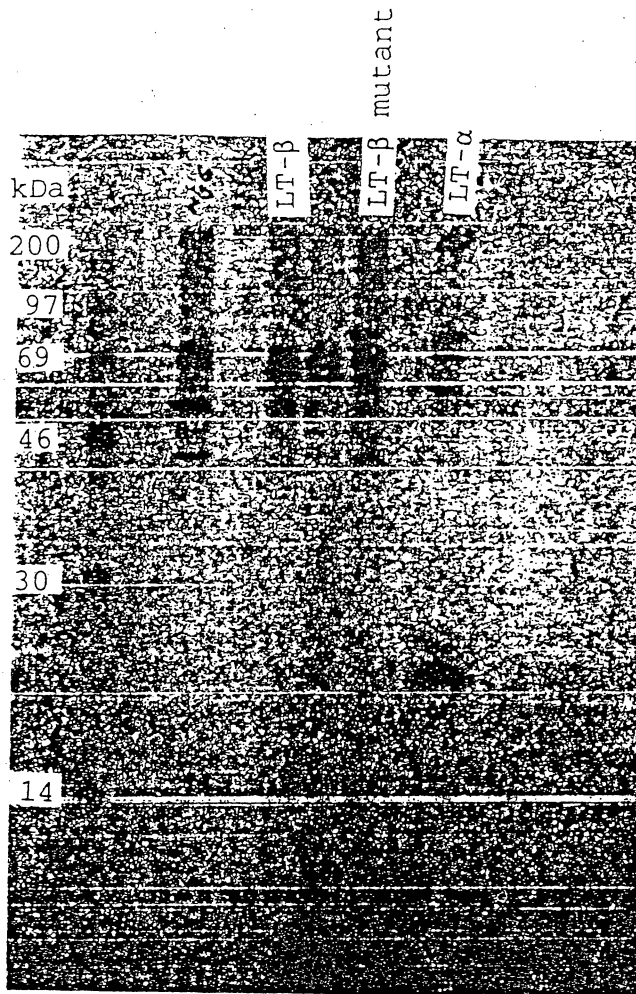

Figure 12. **Autoradiograph of protein immunoprecipitation.** Transfection of COS-7 cells with LT- $\alpha$ , LT- $\beta$  and LT- $\beta$  mutant followed by immunoprecipitation with monoclonal antibodies yielded a band at 26 kD for LT- $\alpha$  indicating a successful transfection. Known weight markers are at 200, 97, 69, 46, 30 and 14 kDa. No bands are present for either LT- $\beta$  sample. The lack of bands may indicate LT- $\beta$  is being rapidly degraded when no LT- $\alpha$  is present.

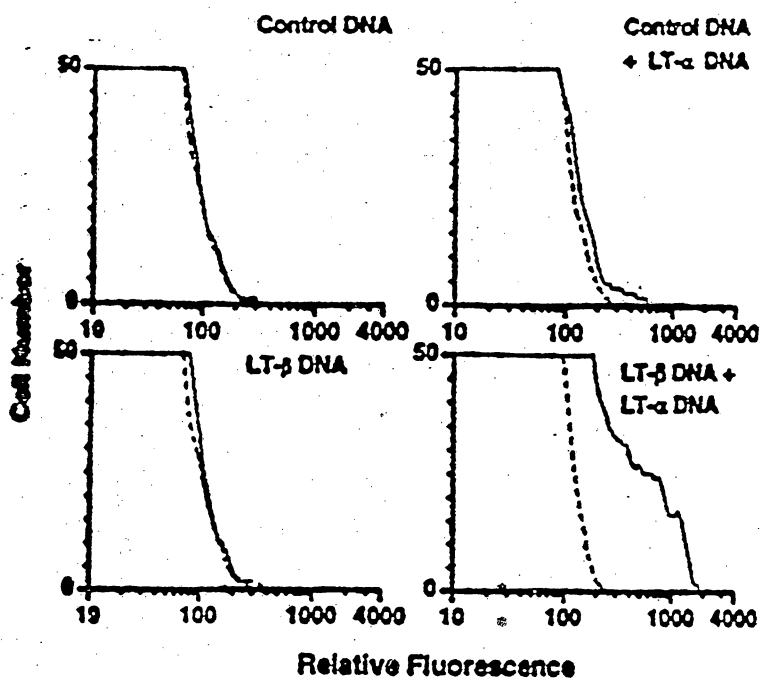

Figure 13. **Flow cytometry data showing surface expression of LT- $\alpha$ / $\beta$  on COS-7 cells.** The relative fluorescence created by staining LT $\alpha$ / $\beta$  cotransfected COS-7 cells with anti-LT- $\alpha$  is shown as a solid line and the background fluorescence due to control IgG staining is shown as a dashed line. Note no relative change when LT- $\alpha$  is expressed alone, this is because the LT- $\alpha$  is not retained on the cell surface. LT- $\beta$  when expressed alone is not stained with the anti-LT- $\alpha$ , but when expressed with LT- $\alpha$  in a cotransfection experiment it causes LT- $\alpha$  to be targeted to the cell surface and retained, where it is stained by the antibody. (From Browning et al., 1993)

## DISCUSSION

The preparation of a site-specific DNA mutant of LT- $\beta$  was shown to be possible using the PCR overlap extension technique. Although this technique was first demonstrated to be a practical and efficient method of site-specific mutagenesis several years ago, when utilized with the LT- $\beta$  gene several modifications were required. The LT- $\beta$  gene is very C-G rich in its 5' end, resulting in excessively high melting temperatures and rapid reannealing of the two DNA strands. This made the generation of a 5' mutant DNA fragment very difficult and impractical using standard PCR protocols. After trying a wide variety of reaction conditions without success, the reactions were attempted in a vessel containing 10% DMSO. Although not normally used in PCR protocols utilizing Taq polymerase, DMSO was used previously in Klenow-mediated PCR reactions (Scharf *et al.*, 1986). Although DMSO is known to reduce the effectiveness of Taq polymerase by approximately 50%, its use in these reactions allowed for the generation of mutant 5' fragments at relatively good levels, yielding approximately 1  $\mu$ g of mutant DNA per 100  $\mu$ l reaction. It is uncertain which parameters are affected by inclusion of 10% DMSO, but DMSO may affect the melting temperature of the primers, the thermal activity profile of the Taq polymerase and/or the degree of product strand separation during denaturation. Even at denaturation temperatures of 99 $^{\circ}$ C, reactions involving

the 5' end of this gene attempted without DMSO were not successful, while addition of 10% DMSO allowed reactions to take place with denaturation temperatures of 95°C. Inclusion of 10% DMSO was also required in the subsequent overlap extension protocols to create full length mutant LT- $\beta$  cDNA.

Once the full length cDNA was produced, it was sequenced in the region surrounding the mutation site to confirm the presence of the mutation and the absence of other random mutations. Full length sequencing will be necessary eventually since random mutations can be created while using Taq polymerase at a rate approaching 1/4000 base pairs (Ho et al., 1989). Since sequencing is time consuming and tedious, full length sequencing will be performed only if changes in binding characteristics, cytotoxicity or trimer formation using the mutant DNA are observed in future assays. The use of the Sequenase PCR sequencing kit with the 5'Seq and 3'LT- $\beta$ /Not-1 primers allowed for direct sequencing of both strands of the PCR product a distance of 100 bp either side of the desired mutation. No mutations other than the desired mutation were observed and the sample was then digested with Not 1 and Hind III and cloned into the pCDNA1-amp plasmid. *E. Coli* cells were subsequently transformed to generate high yields of the desired mutant DNA (approximately 250  $\mu$ g per maxi-prep).

Following isolation of the amplified plasmid from *E. Coli*, the mutant DNA was transfected into COS-7 cells to

obtain protein expression in a mammalian expression system for immunoprecipitation analysis. A sampling of three different monoclonal antibodies were used to ensure the desired epitope had not been inadvertently removed by the mutation. Results of the immunoprecipitation were inconclusive. LT- $\beta$  was not expressed at high enough levels to observe any protein in the autoradiograph (Figure 12). If the protein had precipitated as expected, a band would have been seen at approximately 33 kDa in the wild type LT- $\beta$  sample and a band of slightly greater mobility would have been expected for the LT- $\beta$  lacking the N-linked glycosylation site due to lack of the sugar residue. A control transfection of LT- $\alpha$  precipitated with an anti-LT- $\alpha$  monoclonal antibody yielded the expected band at 26 kDa. Several other attempts to precipitate wild type LT- $\beta$  from COS-7 cells have also failed to detect protein. Flow cytometry analysis of cells transfected with LT- $\beta$  has shown that very small quantities of the protein are present when expressed in conjunction with LT- $\alpha$  (Figure 13). The promoter on the pcDNA1-amp plasmid is a strong promoter, so fairly high levels of protein expression should be expected. This would seem to indicate that rapid protein degradation may be taking place. Co-transfection of COS-7 cells using both LT- $\alpha$  and LT- $\beta$  has been attempted with no LT- $\beta$  evident on the autoradiograph (not shown). It is not known whether a sufficient number of cells are receiving both plasmids to yield distinguishable bands of



$\alpha$ - $\beta$  co-expression on the autoradiograph. An interesting feature of these cotransfections is that the relative level of LT- $\alpha$  expression drops as the amount of LT- $\beta$  transfected increases. This would seem to indicate that the presence of LT- $\beta$  is having some effect on LT- $\alpha$  expression, but the nature of this effect is unclear.

In baculovirus-infected insect cells, LT- $\beta$  is expressed alone or with LT- $\alpha$  in cotransfected cells at very high levels (Crowe, unpublished data). This data may indicate that LT- $\beta$  alone (which has never been observed naturally) contains a signal sequence that directs the LT- $\beta$  proteins down a degradative pathway when expressed in mammalian cells. In insect cells, this pathway may be overwhelmed, so the protein is expressed. However, in these cells, the protein is seen in forms not normally observed, from monomers to aggregates, indicating that even though it is expressed, it is expressed in states not normally seen. When LT- $\alpha$  is coexpressed with LT- $\beta$ , heterotrimers are seen similar to those found in normal mammalian cells. Together, this may indicate a change in the 3-dimensional conformation is occurring upon subunit interaction which signals a secretory pathway. Another possibility is that the LT- $\alpha$  subunit contains a secretory signal and this subunit blocks the degradative signal on LT- $\beta$  when the subunits are together. To examine if some signal in the transmembrane or cytoplasmic domains are signaling for protein degradation, a soluble chimeric LT- $\beta$ /myc construct was

prepared (Biogen) in which the transmembrane and cytoplasmic regions of LT- $\beta$  had been removed and replaced with the myc protein start sequence. This chimeric protein was expressed by COS-7 cells at levels similar to those seen for LT- $\alpha$  (Crowe *et al.*, 1994). This would indicate that the signal for the degradative pathway is located somewhere in the transmembrane or cytoplasmic domains of LT- $\beta$ .

Further analysis of LT through the use of the mutant DNA created in this research will have to await the insertion of the mutant gene into a baculovirus vector. Although the data generated by transfection of COS-7 cells was interesting and valuable, it has not answered any questions concerning the role of the N-linked glycosylation site in receptor binding interactions or in trimer association. Further studies are in progress to attempt expression of the mutant LT- $\beta$  in the baculovirus expression system. Cotransfections using LT- $\alpha$  and LT- $\beta$  in the baculovirus system should yield adequate protein to address these questions.

The importance of working out the protocols required to prepare LT- $\beta$  mutants using the overlap extension technique cannot be underestimated and will allow many important questions about LT- $\beta$  and the immune response to be answered in the future. This project has led to the preparation of one LT- $\beta$  mutant and has also worked out easy and rapid protocols that should allow for future research using LT- $\beta$  mutants to be done quickly and efficiently.

## References

- Abbas, A.K., Lichtmann, A.H., and Pober, J.S., "Cellular and Molecular Immunology", W.B. Sanders Co., Philadelphia, Pa., 1991.
- Allen, R.C., Armitage, R.J., Conely, M.E., Rosenblatt, H., Jenkins, N.J., Copeland, N.G., Bedell, M.A., Edelhoff, S., Disteché, C.M., Simoneaux, D.K., Fanslow, W.C., Belmont, J., and Spriggs, M.K., CD40 ligand gene defects responsible for X-linked hyper Ig-M syndrome. *Science* 259:990-993, 1993.
- Andrews, J.S., Berger, A.E., and Ware, C.F., Characterization of the receptor for tumor necrosis factor (TNF) and lymphotoxin (LT) on human T lymphocytes: TNF and LT differ in their receptor binding properties and the induction of MHC class I proteins on a human CD4+ T cell hybridoma. *J. Immunol.* 144:2582-2591, 1990.
- Androlewicz, M.J., Browning, J.L., and Ware, C.F., Lymphotoxin is expressed in a heterotrimeric complex with a distinct 33 kDa glycoprotein on the surface of an activated human T cell hybridoma. *J. Biol. Chem.* 276:2542-2547, 1992.
- Banner, D.W., D'Arcy, A., James, W., Gentz, R., Schoenfeld, H.-J., Broger, C., Loetscher, H., and Lesslauer, W., Crystal structure of the soluble human 55 kd TNF receptor-human TNF- $\beta$  complex: implications for TNF receptor activation. *Cell* 71:765-776, 1993.
- Browning, J.L., and Ribolini, A., Studies on the differing effects of tumor necrosis factor and lymphotoxin in the growth of several human tumor lines. *J. Immunol.* 143:1859-1867, 1989.
- Browning, J.L., Androlewicz, M.J. and Ware, C.F., Lymphotoxin and an associated 33-kDa glycoprotein are expressed on the surface of an activated human T cell hybridoma. *J. Immunol.* 147:1230-1237, 1991.
- Browning, J.L., Ngam-ek, A., Lawton, P., DeMarinis, J., Tizard, R., Chow, E.P., Hession, C., Greco, B., Foley, S., and Ware, C.F., Lymphotoxin- $\beta$ : A new member of the TNF family that forms a heteromeric complex with lymphotoxin on the cell surface. *Cell* 72:847-856, 1993.

- Crowe, P.D., VanArsdale, T.L., Walter, B.N., Ware, C.F., Hession, C., Ehrenfels, B., Browning, J.L., Din, W.S., Goodwin, R.G., and Smith, C.A., A lymphotoxin- $\beta$ -specific receptor. *Science* 264:707-709, 1994.
- Digel, W., Porzolt, F., Schmid, M., Herrmann, F., Lesslauer, W. and Brockhaus, M., High levels of circulating soluble receptors for tumor necrosis factor in Hairy cell leukemia and type B chronic lymphocytic leukemia. *J. Clin. Invest.* 89:1690-1693, 1992.
- DiSanto, J.P., Bonnefoy, J.Y., Gauchat, J.F., Fischer, A., and Saint Basile, G.de, CD40 ligand mutations in X-linked immunodeficiency with hyper-IgM. *Nature* 361:541-543.
- Engelmann, H., Novick, D., and Wallach, D., Two tumor necrosis factor binding proteins purified from human urine. *J. Biol. Chem.* 265:1531-1536, 1990.
- Gooding, L.R., Virus proteins that counteract host immune defenses. *Cell* 71:5-7, 1992.
- Goodwin, R.G., Anderson, D., Jerzy, R., Davis, T., Brannan, C.I., Copeland, N.G., Jenkins, N.A., and Smith, C.A., Molecular cloning and expression of the type 1 and type 2 murine receptors for tumor necrosis factor. *Mol. Cell. Biol.* 11:3020-3026, 1991.
- Ho, S.N., Hunt, H.D., Horton, R.M., Pullen, J.K., and Pease, L.R., Site-directed mutagenesis by overlap extension using the polymerase chain reaction. *Gene* 77:51-59, 1989.
- Hohmann, H., Remy, R., Brockhaus, M., and Van Loon, A.P.G.M., Two different cell types have different major receptors for human tumor necrosis factor (TNF  $\alpha$ ). *J. Biol. Chem.* 264:14927-14934, 1989.
- Hollenbaugh, D., Grosmaire, L.S., Kullas, C.K., Chalupny, N.J., Braesch-Anderson, S., Noelle, F.J., Stamenkovic, I., Ledbetter, J.A., and Aruffo, A., The human T cell antigen gp39, a member of the TNF gene family, is a ligand for the CD40 receptor: Expression of a soluble form of gp39 with B cell costimulatory activity. *EMBO J.* 11:4313-4321, 1992.

- Horiuchi, A., Abe, Y., Miyaki, M., Kimura, K., Hitsumoto, Y., Takeuchi, N., and Kimura, S., Role of membrane-associated lymphotoxin (mLT) in the killing activity of lymphokine-associated killer (LAK) cells towards various tumor cell lines. *Clin. Exp. Immunol.* 96:152-157, 1994.
- Horton, T.M., Ranheim, T.S., Aquino, L., Kusher, D.I., Saha, S.K., Ware, C.F., Wold, W.S.M., and Gooding, L.R., Adenovirus E3 14.7K protein functions in absence of other adenovirus proteins to protect transfected cells from tumor necrosis factor cytotoxicity. *J. Virology* 65:2629-2639, 1991.
- Jones, E.Y., Stuart, D.I., and Walker, N.P.C., Structure of tumor necrosis factor. *Nature* 338:225-228, 1989.
- Korthauer, U., Graf, D., Mages, H.W., Briere, F., Padayachee, M., Malcolm, S., Ugazio, A.G., Notarangelo, L.D., Levinsky, R.J., and Kroczyk, R.A., Defective expression of T-cell CD40 causes X-linked immunodeficiency with hyper-IgM. *Nature* 326:539-541, 1993.
- Kriegler, M., Perez, C., DeFay, K., Albert, I., and Lu, S.U., A novel form of TNF/Cachectin is a cell surface cytotoxic transmembrane protein: Ramifications for the complex physiology of TNF. *Cell* 53:45-53, 1988.
- Nedwin, G.E., Naylor, S.L., Sakaguchi, A.Y., Smith, D., Jarrett-Nedwin, J., Pennica, D., Goeddel, D.V., and Gray, P.W., Human lymphotoxin and tumor necrosis factor genes: Structure, homology and chromosomal location. *Nucl. Acids Res.* 13:6361-6373, 1985.
- Old, L.J., Tumor necrosis factor (TNF). *Science* 260:630-632, 1985.
- Paul, N.L., and Ruddle, N.H., Lymphotoxin. *Ann. Rev. Immunol.* 6:407-438, 1988.
- Pennica, D., Kohr, W.J., Fendly, B.M., Shire, S.J., Raab, H.E., Borchardt, P.E., Lewis, M., and Goeddel, D.V., Characterization of a recombinant extracellular domain of the type I tumor necrosis factor receptor: evidence for tumor necrosis factor- $\alpha$  induced aggregation. *Biochemistry* 31:1134-1141, 1992.

- Ruddle, N.H., Bergman, C.M., McGrath, K.M., Ligenheld, E.G., Grunnet, M.L., Padula, S.J., and Clark, R.B., An antibody to lymphotoxin and tumor necrosis factor prevents transfer of experimental allergic encephalomyelitis. *J. Exp. Med.* 172:1193-1200, 1990.
- Scharf, S.J., Horn, G.T., and Erlich, H.A., Direct cloning and sequence analysis of enzymatically amplified genomic sequences. *Science*, 233:1076-1078, 1986.
- Schultze, S., Potthof, K., Machleidt, T., Berkovic, D., Wiegmann, K., and Kronke, M., TNF activates NF- $\kappa$ B by phosphatidylcholine-specific phospholipase C-induced "acidic" sphingomyelin breakdown. *Cell* 71:765-776, 1992.
- Smith, C.A., Davis, T., Wignall, J.M., Din, W.S., Farrah, T., Upton, C., McFadden, G., and Goodwin, R.G., T2 open reading frame from the Shope fibroma virus encodes a soluble form of the TNF receptor. *Biochem. Biophys. Res. Commun.* 176:35-342, 1991.
- Smith, C.A., Williams, D., Armitage, R.J., Gliniak, B., Grabstein, K., Fanslow, W., Farrah, T., Falk, B., Din, W.S., Davis, T., and Goodwin, R.G., The TNF/NGF superfamily of cytokines and receptors. *J. Cell. Biochem.* 17B:51. Keystone Symposium Feb. 1-8, 1993.
- Smith, R.A., and Baglioni, C., The active form of tumor necrosis factor is a trimer. *J. Biol. Chem.* 262:6951-6954, 1987.
- Spies, T., Morton, C.C., Nedospasov, S.A., Fiers, W., Pious, D., and Strominger, J.L., Genes for tumor necrosis factor  $\alpha$  and  $\beta$  are linked to the major histocompatibility complex. *Proc. Natl. Acad. Sci., USA*, 83:8699-8702, 1986.
- Togni, P.D., Goellner, J., Ruddle, N.H., Streeter, P.R., Fick, A., Mariathasan, S., Smith, S.C., Carlson, R., Shornick, L.P., Strauss-Schoenberger, J., Russell, J.H., Karr, R. and Chapin, D.D., Abnormal development of peripheral lymphoid organs in mice deficient in lymphotoxin. *Science* 264:703-707, 1994.
- Van Ostade, X., Vandenabeele, P., Everaerd, B., Loetscher, H., Gentz, R., Brockhaus, M., Lesslauer, W., Tavernier, J., Brouckaert, P., and Fiers, W., Human TNF mutants with selective activity on the p55 receptor. *Nature* 361:266-269, 1993.

- Vandenabeele, P., Declercq, W., Vercammen, D., Van de Craen, M., Grooten, J., Loetscher, H., Brockhaus, M., Lasslauer, W., and Fiers, W., Functional characterization of the human tumor necrosis factor receptor p75 in transfected rat/mouse T cell hybridoma. *J. Exp. Med.* 176:1015-1024, 1992.
- Vilcek, J., and Lee, T.H., Tumor necrosis factor: New insights into the molecular mechanisms of its multiple actions. *J. Biol. Chem.* 266:7313-7316, 1991.
- Ware, C.F., Andrews, J.S., Shamansky, L.M., and Grayson, M.H., Regulation of the CTL lytic pathway by tumor necrosis factor. In "Cellular Immunity and the Immunotherapy of Cancer". Lotze, M.T. and Finn, O.J., eds. Wiley-Liss, New York, New York. pp 121-128, 1990.
- Ware, C.F., Crowe, p.D., Grayson, M.H., Androlewicz, M.J., and Browning, J.L., Expression of surface lymphotoxin and tumor necrosis factor on activated T, B and NK cells. *J. Immunol.* 149:3881-3888, 1992.
- Zhang, X-M., Webber, I., and Chen, M-J., Site directed mutational analysis of human necrosis factor- $\alpha$  receptor binding site and structural-functional relationship. *J. Biol. Chem.* 267:24069-24074, 1992.