



UNIVERSITÀ
DEGLI STUDI
DI PADOVA

Università degli Studi di Padova

Padua Research Archive - Institutional Repository

Advancements in hybrid photovoltaic-thermal systems: performance evaluations and applications

Original Citation:

Availability:

This version is available at: 11577/3227176 since: 2017-05-03T15:07:34Z

Publisher:

Elsevier Ltd

Published version:

DOI: 10.1016/j.egypro.2016.11.063

Terms of use:

Open Access

This article is made available under terms and conditions applicable to Open Access Guidelines, as described at <http://www.unipd.it/download/file/fid/55401> (Italian only)

(Article begins on next page)



71st Conference of the Italian Thermal Machines Engineering Association, ATI2016, 14-16
September 2016, Turin, Italy

Advancements in hybrid photovoltaic-thermal systems: performance evaluations and applications

Marco Noro*, Renato Lazzarin, Giacomo Bagarella

*Department of Management and Engineering – University of Padua
stradella San Nicola, 3 – 36100 Vicenza (VI) - Italy*

Abstract

Due to European Directives the electric and thermal energy needs of new and retrofitted buildings have to be satisfied by increasing percentages of renewable energy. Solar energy and heat pumps are the most promising technologies mainly in residential buildings as they have reached great maturity. PhotoVoltaic / Thermal cogeneration (PV/T) aims to utilize the same area both for producing electricity and heat. As solar cells are sensitive to temperature (their efficiency lowers when temperature increases), heat is beneficially collected. This paper provides a description of the applications of the photovoltaic-thermal systems, such as building integrated PV/T, concentrating PV/T systems and photovoltaic-thermal heat pump systems.

© 2016 The Authors. Published by Elsevier Ltd. This is an open access article under the CC BY-NC-ND license (<http://creativecommons.org/licenses/by-nc-nd/4.0/>).

Peer-review under responsibility of the Scientific Committee of ATI 2016.

Keywords: heat pump; hybrid solar system; photovoltaic, PV/T, thermal collector.

1. Introduction

Not all the wavelengths of the incoming irradiation are usefully converted into electricity in PV cells: commercially available single junction PV cells convert between 6 % and 25 % (under optimum operating conditions and depending on the semiconductor material) into electricity, while the rest is dissipated as heat [1]. This is due to the band-gap energy of the semiconductor material. For example, crystalline silicon PV cells can utilize the entire visible spectrum plus some part of the infrared spectrum, but the energy of all the other wavelengths (the far

* Corresponding author. Tel.: +39 0444998704; fax: +39 0444998884.
E-mail address: marco.noro@unipd.it

infrared and the higher energy radiation) is unusable in order to be converted in electricity and instead is dissipated at the cell as thermal energy. The main drawback is that the PV module can reach temperatures as high as 40 °C above ambient; this causes an increased intrinsic carrier concentration which tends to increase the dark saturation current of the p–n junction. The main effect is the decreasing of the available maximum electrical power, typically 0.2–0.5 % for every 1 °C rise in the PV module temperature for crystalline silicon cells.

Another critical issue for improving performance of PV systems is maintaining a homogeneous low temperature distribution across the string of cells: as the cell efficiency decreases with increasing temperature, the cell having the highest temperature and so producing the least output in series string of cells limits the current and so the electric power produced (current matching).

The well known main idea to face the issues just described is to increase the electrical production of PV by decreasing the normal operating cell temperature by cooling the panel by a liquid (or air). So PhotoVoltaic/Thermal technology (PV/T) aims to utilize the same area both for producing electricity and heat. This also implies to have higher global efficiency with an enhanced use of solar energy ([2] [3]). Different methods can be applied to cool the PV systems depending on the PV technology (solar concentration, type of cells, etc.) and the climate conditions. The main two categories are:

- passive cooling: this refers to technologies used to extract and/or minimize heat absorption from/of the PV panel without additional power consumption. The heat extracted can be dissipated or usefully used. For example, the application of high thermal conductivity metals, such as aluminum and copper, or an array of fins enhances heat transfer to the ambient. Other passive systems are the use of Phase Change Materials (PCM) or the use of heat pipes that are able to transfer heat efficiently through a boiling–condensing process;
- active systems: in this case heat extraction from the PV panel is forced by the utilization of devices such as fans (for air) or pump (for water or other refrigerant liquid). The heat transfer is therefore enhanced with respect to the passive systems even if they consume some energy. These systems may also be used in situations where some additional benefit can be achieved, such as waste heat recovery for domestic water heating. The main application are the PV/T plane o concentrating solar collectors.

PV/T systems are classified into different categories depending on the structure or functionality of the designs. In terms of heat extraction employed, PV/T modules could be classified as air, liquid, heat pipe, phase change materials, and thermoelectric-based types (sections 2 and 3). In terms of the system structure, the modules could be classified as flat-plate, concentrated, building integrated (BIPV), and heat pump-coupled types.

2. PV/T air collectors

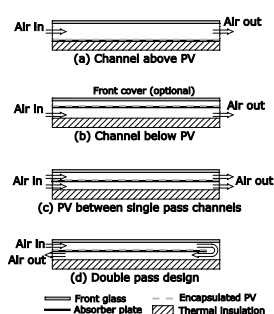

Fig. 1. Different configurations of PV/T air cooled flat plate collectors, with and without glass cover

Air PV/T and ventilated PV façade systems have widely been applied to cool PV cells and to produce low grade thermal energy for space heating in residential applications [4]. No high electrical and thermal efficiency are possible with respect to the water cooled PV/T collectors (section 3) due to the low density and small heat capacity of air. Anyway, they are an economical and useful option when water is limited. Different design concepts have been developed with respect to air flow patterns and to presence of front glazing in order to achieve optimum performance of PV/T modules (Fig. 1).

Fig. 2 depicts two of the four different configurations that were investigated in [5], namely, (1) glass-to-glass PV module with duct, (2) glass-to-glass PV module without duct, (3) glass-to-temlar PV module with duct, and (4) glass-to-temlar PV module without duct.

The presence of the duct allows to increase the electrical efficiency, even more with the glass-to-glass PV module type with respect to the glass-to-temlar type (Fig. 2c). Also air outlet temperature was higher in the case of glass-to-glass because the radiation was transmitted through the back glass. Meanwhile, in the case of glass-to-temlar the radiation is absorbed by the temlar layer and conducted away resulting in higher cell temperature.

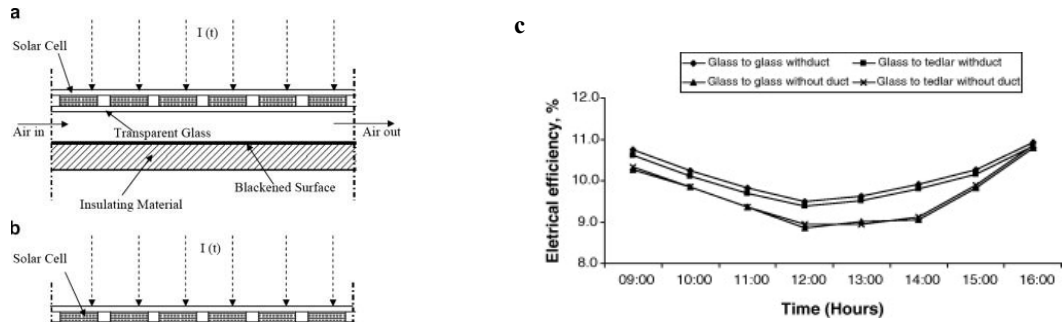

Fig. 2. (a) Glass-to-glass PV module with duct; (b) glass-to-tedlar PV module with duct; c) electrical efficiency of PV cells for collectors investigated in [5]

Another study [6] suggested two low cost modification techniques to improve thermal performance of natural ventilated air-based PV/T collectors: a thin metal sheet suspended at the middle of the air channel (TMS), and a finned metal sheet at the back wall of the air duct (FIN), Fig. 3.

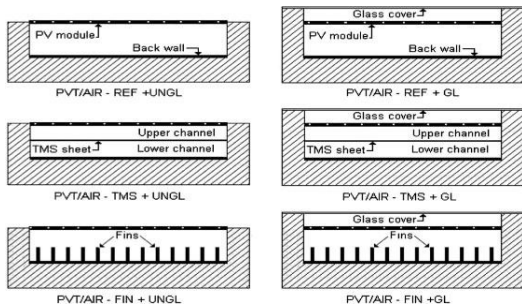

Fig. 3. Air-based PV/T collectors with thin metal sheet (TMS) and finned metal sheet (FIN) [6]

The models were validated against the experimental data for both glazed and unglazed PV/T collectors using a commercial poly-crystalline silicon PV module rated at $46 W_p$, and aperture area of $0.4 m^2$. The model results showed that the modified systems gave better thermal efficiency for every parameter considered with the FIN system giving better performance than the TMS system. The results also showed that there was an optimum channel depth (15 cm) at which mass flow rate, hence thermal efficiency, was at maximum, PV module temperature was reduced of about $3 ^\circ C$ compared to the reference system, and electrical efficiency improved by 1–2 %.

Other configurations have been studied in the recent past [7] (series-parallel air flow arrangement of micro-channel solar cell thermal tiles, V-groove, honeycomb) with the aim of increasing the surface area in direct contact with the PV module and the uniformity of air flow, resulting in enhanced exergy and thermal efficiency that is a higher air outlet temperature (Fig. 4).

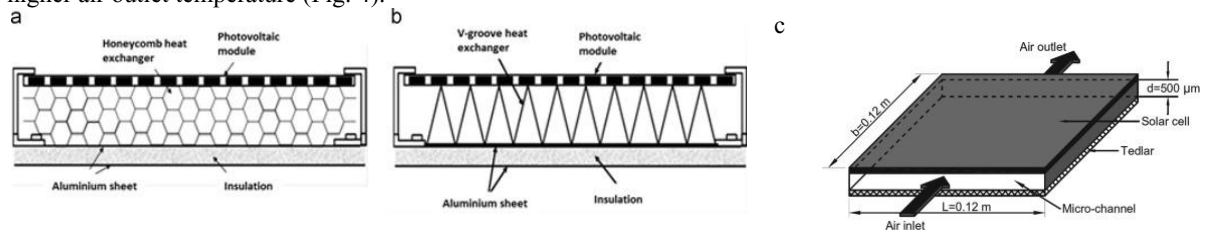

Fig. 4. PV modules with different heat exchanger designs: (a) honeycomb, (b) V-groove, (c) micro-channel solar cell thermal tile [7]

3. PV/T liquid collectors

Liquid-based PV/T collectors allow some advantages with respect to air cooled ones due to higher specific heat capacity of coolants employed leading to improved overall performance and less temperature fluctuations. The

typical configuration comprises of metallic sheet-and-tube absorber in which heat extraction is attained via forced fluid circulation through series/parallel-connected pipes adhered to the rear of PV collector [4] [8] [9]. Water is largely used as working fluid; however, refrigerants that are able to undergo phase change at a relatively low temperature can be adopted in systems combining PV/T collectors and solar-assisted heat pumps.

3.1. Water PV/T collectors

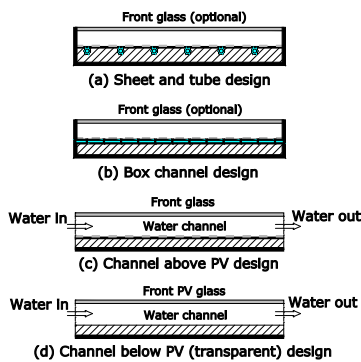

Many experimental and theoretical studies have been done in the recent past on the performance of PV/T water cooled plane collectors [7] [8] [10]. Such performances strongly depend on the channels absorber design, the glazed or unglazed configuration and the flow rate and inlet temperature of thermal fluid (Fig. 5). An experimental study was carried out by the authors in order to investigate the efficiencies obtainable by some kinds of PV/T water cooled plane collectors. A PV/T test rig was set in Vicenza (north-east of Italy) on a flat roof of a building which is part of the Department of Industrial Management and Engineering (University of Padua) [11] [12].

Fig. 5. Different configurations of water-based PVT collectors

The tested collectors were (Fig. 6):

- COGEN: flat plate, glazed, PV single-crystalline module with a gross area of 1.2 m^2 , nominal power of 135 W_p and electrical efficiency of 11.2% (without cover glass) at standard conditions, designed and built by the authors. The absorber is a roll-bond type made of aluminium and suitably glued to the Tedlar film of the PV laminate; 25 mm of polystyrene is used as rear absorber insulation;
- PVTWIN – model 422: manufactured by the PVTWINS (The Netherlands). It is a flat plate, glazed collector, PV cells are multi-crystalline type with a gross area of 2.54 m^2 , nominal power of 295 W_p and electrical efficiency of 11.6% . The absorber is a plate-and-tube type made of copper, properly glued to the rear part of the PV laminate and insulated with 40 mm of polyurethane;
- MSS: manufactured by the Millennium Electric T.O.U. (Israel). It is a flat plate, unglazed, liquid/air cooled collector, PV cells are multi-crystalline type with a gross area of 2.7 m^2 , nominal power of 300 W_p and electrical efficiency of 11.5% . The absorber is a plate-and-tube type made of aluminium: pipes are all in parallel together with air channels;
- HYBRIS: manufactured by SY.T.EN. (Italy). It is a flat plate, unglazed collector, PV is a 72 single-crystalline cells module with a gross area of 1.27 m^2 , nominal power of 170 W_p and electrical efficiency of 13.3% at standard conditions;
- THYBRIS: design and manufactured by the authors, made by a copper selective solar thermal collector whose glass has been substituted by a thin film PV layer (amorphous silicon, transparency 10% , output electrical power 52 W). The gross area is 2.09 m^2 , so two PV glasses are used, physically connected by silicone and electrically connected in parallel.

Experimental analysis on the different PV/T liquid cooled collectors highlighted that when global solar radiation was high ($700\div 800 \text{ W m}^{-2}$) glazed collectors needed high values of water mass flow rate, in order to guarantee an appropriate cooling of the PV laminate thus limiting the negative influence of temperature increase on PV performance. With unglazed collectors, conversely, lower mass flow rates were better in order not to penalize too much thermal production. For the same reason, when global solar radiation was lower ($350\text{--}400 \text{ W m}^{-2}$), for both glazed and unglazed technologies it was advisable to use lower mass flow rates. So unglazed collectors are preferable at latitudes with high annual global solar radiation, glazed ones at latitudes with low annual global solar radiation. In order to minimize dangerous stagnation effects (typical of glazed modules) and, at the same time, to not penalize too much thermal production, the THYBRIS collector was developed by the authors. The main idea was to transfer the PV layer from behind to over the glazing, by the use of a semitransparent PV instead of a simple glass.

Such a PV/T collector would have the PV layer cooled also by the ambient air (and, indirectly, by the fluid) while the absorber would have a quite similar behaviour as a traditional thermal collector. Experimental results showed that thermal efficiency was quite low, definitely lower than conventional PV/T glazed and unglazed modules. Also electrical efficiency was lower, but this was a limit of the thin film technology with respect to crystalline one. Furthermore, thin film PV had a lower temperature coefficient, so electrical performance was less penalized with increasing ambient air temperature than crystalline PV.

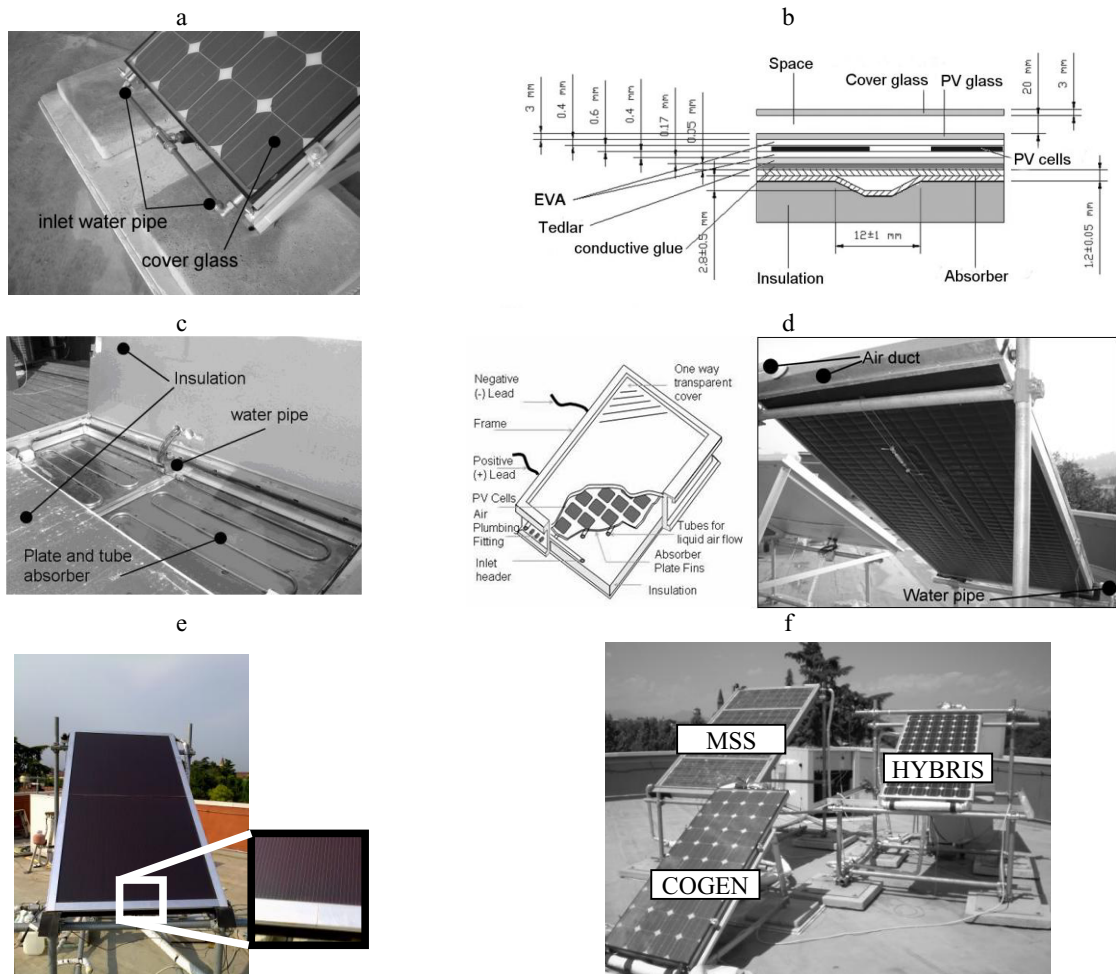

Fig. 6. COGEN: frontal view detail (a) and cross-section view (b); c) PVTWIN: removed back side insulation with plate and tube absorber view; d) MSS: schematic view and rear side of the collector with indication of the inlet water pipe and outlet air duct; e) THYBRIS module, made by a copper selective solar thermal collector whose glass has been substituted by a thin film PV layer (amorphous silicon); f) three PV/T collectors tested in the test rig

3.2. Refrigerant PV/T collectors

In this case the PV/T collector serves as an evaporator of a solar-assisted heat pumps where the refrigerant absorbs thermal energy at low evaporation temperature (0–20 °C) allowing efficient cooling of PV cells and leading to significant increase in the performance ([13]). An example of roof module for electricity generation and acting as an evaporator of a heat pump system is depicted in Fig. 7 ([14]). The PV/T heat pump system was simulated under

typical Nottingham (UK) weather conditions and the performance was evaluated theoretically with R134a refrigerant based on various parameters including top cover material, PV cells technology, and evaporation and condensation temperature. The optimization process indicated a system composed by a mono-crystalline PV cells, borosilicate top cover, evaporation and condensation temperatures of 10 °C and 60 °C respectively; thermal and electrical efficiencies of 60.9 % and 9.2 % respectively were reported. Unbalanced refrigerant distribution, possible leakage of refrigerant, and maintaining pressurization and depressurization at different parts of the system are some of the challenges to be faced to have practical feasibility of such systems [4].

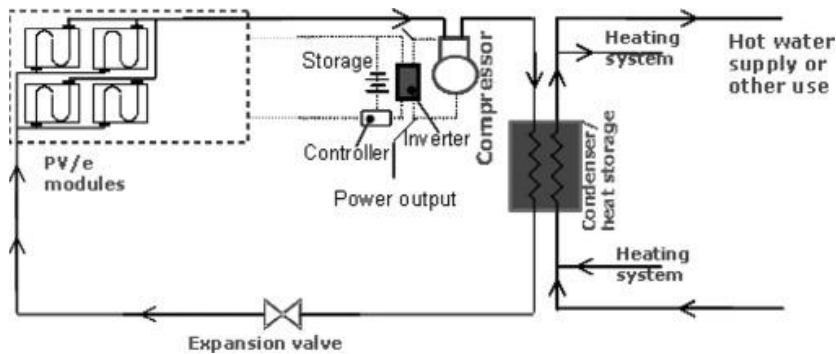

Fig. 7. PV/evaporator heat pump system [14]

3.3. Heat pipe PV/T collectors

Heat pipes for thermal management of PV modules present some advantages: they allow a uniform temperature distribution of PV cells, the elimination of freezing that thermosyphon tube can suffer from in higher latitudes, in addition to resistance to corrosion. The selection of a suitable combination of heat pipe container material and working fluid is a critical aspect to be considered for the effectiveness of the system.

In a recent study [15] a dynamic model of a PV/T collector utilizing heat pipe for heat extraction was developed and experimentally validated under the weather conditions of Hefei, China. The collector comprised of 9 water-copper heat pipes joined together at the back of aluminium plate incorporated at the rear of a PV module. The condenser section was inserted into a heat exchanger. A low-iron-tempered, textured glass plate was used as the upper glazing for the collector preventing thermal losses (Fig. 8). Reported average electrical and thermal energy efficiencies were 10.2 % and 45.7 % respectively with average overall exergy efficiency of the 7.1 %. The parametric analysis based on the validated dynamic model revealed that heat gain, electrical gain, and total PV/T efficiencies (first- and second-law efficiencies) increased with increased water flow rate, with an increasing rate gradually lowering and an influence on heat gain much stronger than on electrical gain.

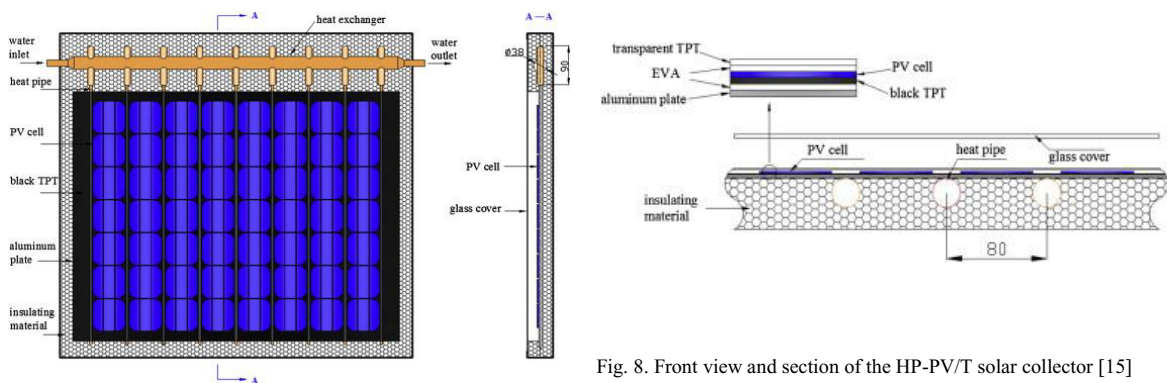

Fig. 8. Front view and section of the HP-PV/T solar collector [15]

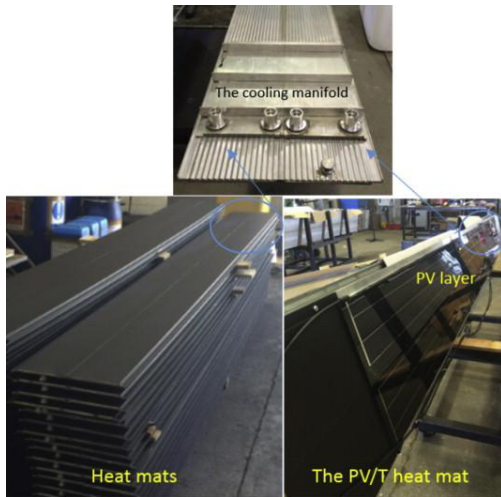

Fig. 9. The multi-channel flat heat pipe PV/T panel [16]

A new flat heat pipe design was recently developed with an internal finning allowing efficient heat transfer from the PV layer on the front surface to boil the heat pipe working fluid [16]. The fluid flows up to the condenser section of the heat pipe that is cooled using a manifold. Interface thermal resistances between the manifold and the back of the condenser section and between the PV layer and the heat pipe front surface are reduced by means of thermally conductive flexible adhesive films (Fig. 9). The system can be utilised to harness solar energy and act as a building envelope. The experimental results on a full scale system mounted in a full size roof showed that, from thermal point of view, the solar/thermal energy conversion efficiency was around 50 %; the effect of cooling on the solar/electrical energy conversion of the PV/T increased the electrical output by about 15 % when compared to uncooled PV. Such a system has also been proved to be an efficient thermal energy absorber from the ambient even without solar radiation, thus enhancing the energy efficiency of the incorporated heat pump system.

3.4. PCM PV/T collectors

Phase Change Materials (PCMs) can absorb and release large amount of energy as latent heat during the phase transition through a reversible (nearly) isothermal process. The most diffuse applications are in passive and active thermal storage in buildings [17] [18]. PCMs present some critical aspect due to their low thermal conductivity (order of $1 \text{ W m}^{-1} \text{ K}^{-1}$ or less), non-linear motion of solid–liquid interface, and volume expansion of the PCM during melting/solidification. A solution to tackle these issues can be the insertion of internal fins to enhance the thermal conductivity of bulk PCM. Thermal performance is mainly influenced by the number, dimension, form of fins, and type of PCM material used.

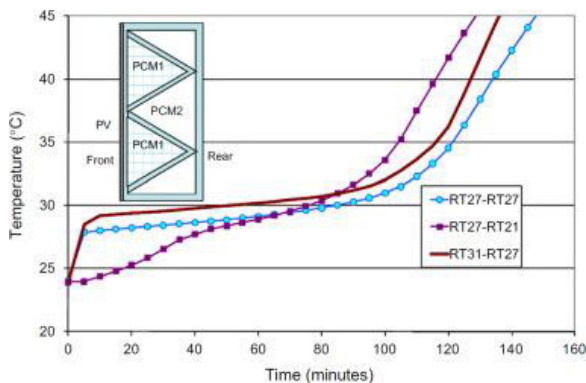

Fig. 10 depicts a study using different combinations of PCMs with different melting temperatures in triangular shaped cells dissipating the stress resulting from volume expansion and extending the thermal regulation period [19]. The results showed that the system with PCMs RT27–RT21 had the lowest temperature rise due to its lower melting temperature, while RT27–RT27 was able to regulate the temperature for a longer period (with solar radiation of 1000 W m^{-2} and ambient temperature of $20 \text{ }^\circ\text{C}$).

Fig. 10. Predicted surface temperature evolution using different combinations of PCMs within PV/PCM system [19]

3.5. Thermoelectric PV hybrid systems

Due to their positive features (compactness, lightness, stillness in operation, reliability, no moving or complex parts) several studies have been conducted to investigate the feasibility of incorporating Thermoelectric Generators (TEG) with PV technology to harvest energy through thermal waste utilization ([20] [21]). For example, in [22] direct non-concentrated sunlight falls onto the PV panel where each cells possesses a back electrode with high

thermal conductivity and in direct thermal contact with the hot plate of corresponding TEG. So the heat generated in each PV cell passes through individual TEG that have good thermal contact with this cell from one side, and with heat extractor from the other side. The improvement in electrical efficiency of such a system increases with the increase of the figure of merit of TEG. Solutions using concentrated solar radiation were tested as well.

4. Conclusions

The paper reports on a brief analysis of the state of the art of hybrid photovoltaic cogeneration that allows to extract heat from PV modules, reducing the operating temperature and improving the electrical efficiency. Furthermore, using the heat for domestic hot water production or building heating needs enhances the conversion rate of the absorbed solar radiation than standard PV modules. Various designs employing air, liquid, heat pipe, PCM, and thermoelectric modules are possible, whereas liquid cooling allows a more efficient utilization of thermal energy and a more homogenous temperature distribution on the surface of PV modules; although water is the most common fluid, refrigerants with phase change at a relatively low temperature have been tested with even better performance. Heat pipes and PCMs however feature high heat transfer rates and heat absorption due to latent heat exchange, allowing a uniform temperature distribution of PV cells. Available current technologies for thermoelectric modules do not allow such improvement in PV performance.

References

- [1] Luque A, Hegedus S. Handbook of photovoltaic science and engineering. 2nd ed. John Wiley & Sons: West Sussex; 2011.
- [2] Theodore L. Heat transfer applications for the practicing engineer. John Wiley & Sons: New Jersey; 2011.
- [3] Chow TT. A review on photovoltaic/thermal hybrid solar technology. *Applied Energy* 2010;87:365-379.
- [4] Zhang X, Zhao X, Smith S, Xu J, Yu X. Review of R&D progress and practical application of the solar photovoltaic/thermal (PV/T) technologies. *Renewable Sustainable Energy Rev* 2012;16:599–617.
- [5] Dubey S, Sandhu GS, Tiwari GN. Analytical expression for electrical efficiency of PV/T hybrid air collector. *Appl Energy* 2009;86:697–705.
- [6] Tonui JK, Tripanagnostopoulos Y. Performance improvement of PV/T solar collectors with natural air flow operation. *Sol En* 2008;82:1–12.
- [7] Makki A, Omer S, Sabir H. Advancements in hybrid photovoltaic systems for enhanced solar cells performance. *Renewable Sustainable Energy Rev* 2015;41:658-684.
- [8] Du D, Darkwa J, Kokogiannakis G. Thermal management systems for photovoltaics (PV) installations: a critical review. *Sol Energy* 2013;97:238–254.
- [9] Zondag HA, De Vries DW, Van Helden WGJ, Van Zolingen RJC, Van Steenhoven AA. The thermal and electrical yield of a PV–thermal collector. *Sol Energy* 2002;72(2):113–128.
- [10] Daghigh R, Ruslan MH, Sopian K. Advances in liquid based photovoltaic/thermal (PV/T) collectors. *Renewable Sustainable Energy Rev* 2011;15: 4156–4170.
- [11] Busato F, Lazzarin R, Noro M. Experimental analysis of photovoltaic cogeneration modules. *International Journal of Low Carbon Technologies* 2008;3(4):221-244.
- [12] Busato F, Lazzarin R, Noro M. Photovoltaic cogeneration: theoretical and experimental analysis of an innovative module. Proceedings 48th International Congress Aicarr “Energy refurbishment of existing Buildings - which solutions for an integrated System: Envelope, Plant, Control”. Baveno. 2011;309-320; ISBN 978-88-95620-44-2.
- [13] Jie J, Kelianga L, Chow TT, Gang P, Wei H, Hanfenga H. Performance analysis of a photovoltaic heat pump. *Appl En* 2008;85:680–693.
- [14] Zhao X, Zhang X, Riffat SB, Su X. Theoretical study of the performance of a novel PV/e roof module for heat pump operation. *Energy Convers Manage* 2011;52:603–614.
- [15] Gang P, Huide F, Huijuan Z, Jie J. Performance study and parametric analysis of a novel heat pipe PV/T system. *Energy* 2012;37:384–395.
- [16] Jouhara H, et al.. The performance of a novel flat heat pipe based thermal and PV/T (photovoltaic and thermal systems) solar collector that can be used as an energy-active building envelope material. *Energy* 2015, <http://dx.doi.org/10.1016/j.energy.2015.07.063>
- [17] Navarro L, de Gracia A, Colclough S, Browne M, McCormack SJ, Griffiths P, Cabeza LF. Thermal energy storage in building integrated thermal systems: A review. Part 1. active storage systems. *Renewable Energy* 2016;88:526-547.
- [18] Navarro L, de Gracia A, Niall D, Castell A, Browne M, McCormack SJ, Griffiths P, Cabeza LF. Thermal energy storage in building integrated thermal systems: A review. Part 2. Integration as passive system. *Renewable Energy* 2016;85:1334-1356.
- [19] Huang M. The effect of using two PCMs on the thermal regulation performance of BIPV systems. *Sol Energy Mater Sol Cells* 2011;95:957–963.
- [20] Vorobiev Y, González-Hernández J, Vorobiev P, Bulat L. Thermal–photovoltaic solar hybrid system for efficient solar energy conversion. *Sol Energy* 2006;80:170–176.
- [21] Zhang X, Chau KT. An automotive thermoelectric–photovoltaic hybrid energy system using maximum power point tracking. *Energy Convers Manage* 2011;52:641–647.
- [22] Chávez-Urbiola EA, Vorobiev YV, Bulat LP. Solar hybrid systems with thermoelectric generators. *Sol Energy* 2012;86:369–378.