

Gravitational wave detectors

This content has been downloaded from IOPscience. Please scroll down to see the full text.

2005 New J. Phys. 7 202

(<http://iopscience.iop.org/1367-2630/7/1/202>)

View [the table of contents for this issue](#), or go to the [journal homepage](#) for more

Download details:

IP Address: 194.95.157.219

This content was downloaded on 22/05/2017 at 14:11

Please note that [terms and conditions apply](#).

You may also be interested in:

[Detection of gravitational waves](#)

L Ju, D G Blair and C Zhao

[Ground-based interferometers and their science reach](#)

Seiji Kawamura

[The search for gravitational waves](#)

Jim Hough, Sheila Rowan and B S Sathyaprakash

[Gravitational wave astronomy](#)

B F Schutz

[Past, present and future of the Resonant-Mass gravitational wave detectors](#)

Odylio Denys Aguiar

[Laser interferometric gravitational wave detectors](#)

Norna A Robertson

[Optical gravitational wave detectors on the ground and in space: theory and technology](#)

Jean-Yves Vinet

[LIGO: the Laser Interferometer Gravitational-Wave Observatory](#)

B P Abbott, R Abbott, R Adhikari et al.

[Third generation of gravitational wave observatories and their science reach](#)

M Punturo, M Abernathy, F Acernese et al.

Gravitational wave detectors

Peter Aufmuth and Karsten Danzmann

Max-Planck-Institut für Gravitationsphysik (Albert Einstein Institut),
Universität Hannover, Callinstr. 38, D-30167 Hannover, Germany
E-mail: peter.aufmuth@aei.mpg.de

New Journal of Physics 7 (2005) 202

Received 6 September 2004

Published 29 September 2005

Online at <http://www.njp.org/>

doi:10.1088/1367-2630/7/1/202

Abstract. The existence of gravitational radiation is a prediction of Einstein's general theory of relativity. Gravitational waves are perturbations in the curvature of spacetime caused by accelerated masses. Since the 1960s gravitational wave detectors have been built and constantly improved. The present-day generation of resonant mass antennas and laser interferometers has reached the necessary sensitivity to detect gravitational waves from sources in the Milky Way. Within a few years, the next generation of detectors will open the field of gravitational wave astronomy.

Contents

1. Introduction	2
2. Required sensitivity	2
3. Resonant mass detectors	3
3.1. Bar detectors	4
3.2. Spherical detectors	6
4. Laser interferometers	6
5. Future detectors	11
5.1. Resonant detectors	11
5.2. Interferometers	11
6. International collaborations	12
6.1. IGEC	12
6.2. LSC	13
7. Outlook	13
References	14

1. Introduction

In 1915 Albert Einstein published his theory of gravitation, general relativity. Only a few months later he predicted the existence of gravitational radiation propagating with the velocity of light [1]. When estimating the luminosity, he came to the conclusion that in all conceivable cases only a virtually vanishing value results. So it will probably never be possible to produce observable gravitational waves in the laboratory. Only compact cosmic objects with large accelerations and large quadrupole moments are suitable sources for gravitational wave detectors. An account of the theory of gravitational waves and of their sources is given in the paper by Flanagan and Hughes in this Focus Issue [2].

After Einstein's basic publications [1, 3], half a century passed until Joseph Weber proposed several schemes for the detection of gravitational radiation [4] and finally decided on resonant-mass detectors ('Weber bars'). After Weber's claim to have detected gravitational waves from the centre of the Milky Way [5, 6], several groups all over the world started on the construction of gravitational wave detectors. However, no other group was able to confirm Weber's findings. Nevertheless, this was the starting point of an intense development of existing detectors and of new concepts. Since the beginning of the 1970s prototypes of laser interferometers have been studied. Thus, one obtained an understanding of the limiting noise sources and developed techniques to improve the sensitivity to the required level.

These efforts have been greatly encouraged by astrophysical observations of the inspiral of the binary pulsar PSR 1913 + 16 [7]. The observed energy loss by means of gravitational waves of this neutron star double system corresponds with Einstein's predictions within 0.3% [8]. This is generally considered an indirect proof of the existence of gravitational radiation in accordance with general relativity. At the beginning of the 21st century, after 30 years of development, gravitational wave detectors are close to their designed sensitivity [9]–[11]. The direct observation of gravitational waves is expected within the next few years. This will open a completely new field of astronomy.

Section 2 defines the basic physical quantities and gives a short account of the technical demands. Section 3 describes the physics of resonant-mass antennas and section 4 those of laser interferometric detectors, each giving a detailed overview of the existing devices. Section 5 summarizes the planned second-generation detectors. Gravitational wave detection requires international collaboration; section 6 reviews the existing networks. In section 7 the importance of gravitational wave astronomy is emphasized.

2. Required sensitivity

Gravitational waves are ripples in the curvature of spacetime [2, 12]. The gravitational wave amplitude (or strain or strength) is usually given as the dimensionless quantity

$$h = \frac{2\delta l_{\text{gw}}}{l}, \quad (1)$$

where δl_{gw} is the change in the proper distance l between two spacetime events, caused by the gravitational wave. It depends on the reduced quadrupole moment I of the source and on the

distance r to the source [13]:

$$h = \frac{2G}{c^4} \frac{1}{r} \frac{\partial^2 I}{\partial t^2} \quad (2)$$

(G is Newton's gravitational constant).

The factor $2G/c^4 = 1.6 \times 10^{-44} \text{ s}^2 \text{ kg}^{-1} \text{ m}^{-1}$ in (2) leads to very small values for the gravitational wave amplitude. Only compact cosmic objects with large accelerations and large quadrupole moments can compensate for this. But even a violent event like a supernova explosion in the Milky Way, at a distance of about 10 kpc, gives a strain h of merely 10^{-20} . From coalescing binaries of neutron stars with masses of about $1.4M_\odot$ in the Milky Way, we expect $h \approx 10^{-19}$, but these are rare events. Thus gravitational wave detectors have to be sensitive enough to reach neighbouring galaxies. The design sensitivity of the first generation of gravitational wave detectors aims at a distance of 20 Mpc for these events; the second-generation detectors aim at distances of 300 Mpc.

Often the performance of a detector is given by the frequency-dependent noise that limits its sensitivity. In particular for stochastic noise, the amplitude spectral density (or linear spectral density) \tilde{h} is used, which is the square root of the power spectrum (or power spectral density):

$$\tilde{h} = \sqrt{S_h(f)} [1/\sqrt{\text{Hz}}]. \quad (3)$$

$S_h(f)$ gives the mean-square value of h at the frequency f within a bandwidth of 1 Hz. If $\tilde{h} \approx \text{const.}$, then for a detector with bandwidth Δf we obtain

$$\tilde{h} \sqrt{\Delta f} = h. \quad (4)$$

3. Resonant mass detectors

A gravitational wave acts like a tidal force across an extended rigid object so that it will be alternately stretched and compressed. Resonant mass detectors use a high- Q mechanical resonator, such as an elastic solid body of length (or diameter) l , whose resonance is excited by the gravitational wave. The response to a short burst of gravitational wave is a displacement of the ends of the mass:

$$\delta l_{\text{gw}} \sim hl \sim 10^{-21} \text{ m} \quad (5)$$

for a mass of 1000 kg and $l \sim 1$ m. The response depends in a complicated way on all the internal forces of the rigid body, but for short-duration signals (5) is a good approximation. The elastic vibrations of the mass are measured by means of a transducer that converts the displacement into an electric signal, which is then amplified. Often the antenna is characterized by an 'effective' temperature

$$T_{\text{eff}} = (T/\beta Q) + 2T_{\text{N}}, \quad (6)$$

where kT_{eff} is the minimum detectable energy, β is the efficiency (or the coupling coefficient) of the transducer, i.e. the ratio between electrical energy and mechanical vibration energy, and T_{N} the noise temperature of the transducer. For a gravitational wave in the kHz range, $2T_{\text{N}} \cong 10^{-7} \text{ K}$.

For active transducers β can be larger than unity because of parametric amplification of the signal.

The main sources of noise competing with the small amplitude (5) are the following.

Thermal noise. This is due to the Brownian motion of the oscillator. The rms amplitude of vibration is found by setting the kinetic energy of the normal mode, $M(\delta\dot{l})^2/2$, equal to $kT/2$. At room temperature, this leads to an amplitude of about 10^{-16} m, far larger than δl_{gw} . One has to use resonators with a high quality factor Q ($\sim 10^7$) that are cooled down to $T \approx 0.1$ K. For a signal of 1 ms duration, one obtains

$$\langle \delta l^2 \rangle_{\text{th}}^{1/2} = \left(\frac{kT}{4\pi^2 M f_0^2 Q} \right)^{1/2} \sim 6 \times 10^{-21} \text{ m}, \quad (7)$$

where f_0 is the resonance frequency.

Sensor noise. Transducers introduce noise; this limits the detector sensitivity to frequencies near f_0 . The transducer's bandwidth should be at least $\Delta f \sim 1/\tau_{\text{gw}}$, where τ_{gw} is the duration time of the signal (about 1 ms for a typical gravitational wave burst). Present-day transducers have a bandwidth of some tens of Hz, but one hopes to extend this to 100 Hz or more.

Quantum limit. According to the Heisenberg uncertainty principle, the zero-point vibrations of a bar with a frequency of 1 kHz have an rms amplitude of

$$\langle \delta l^2 \rangle_{\text{qu}}^{1/2} = \left(\frac{\hbar}{2\pi M f_0} \right)^{1/2} \sim 4 \times 10^{-21} \text{ m}. \quad (8)$$

3.1. Bar detectors

The first gravitational wave detectors were large cylindrical masses of an aluminium alloy (Al 5056). The wave excites the odd longitudinal vibration modes of the cylinder. Today, a typical bar has a length l of about 3 m, a mass M of about 1000 kg and a resonance frequency f_0 of about 1 kHz. It is operated at the temperature of liquid helium. The vibrations are detected by means of a resonant transducer (e.g., a microwave cavity) coupled to a very low-noise dc SQUID amplifier (see figure 1).

The vibration amplitude of the bar is increased in the transducer by a factor $\sqrt{M/m}$, where M is the mass of the antenna and m the equivalent mass of the transducer. Bar and transducer act as two coupled oscillators in series, thus the output signal appears at two sidebands $f_{\pm} = f_0(1 \pm \sqrt{\mu}/2)$ with $\mu = \sqrt{m/M}$. A typical sensitivity curve is given in figure 2.

Resonant bar detectors have been operating since many years. At present, they have a burst sensitivity of $h \sim 4 \times 10^{-19}$ and a bandwidth Δf of some tens of Hz [15, 16]. The projects in alphabetical order are the following.

ALLEGRO has been operated since 1991 by the Louisiana State University at Baton Rouge (LA, USA). It is a 2296 kg Al antenna cooled down to 4.2 K. The resonance frequencies are 895 and 920 Hz. The transducer is a mushroom-shaped superconducting inductive device. The magnetic signal is sent to a dc SQUID. After an upgrade of the transducer to a two-stage device in 2001/2002, a sensitivity of $\tilde{h} \sim 10^{-21}/\sqrt{\text{Hz}}$ and a bandwidth of about 60 Hz is to be expected [17].

Homepage: <http://gravity.phys.lsu.edu>

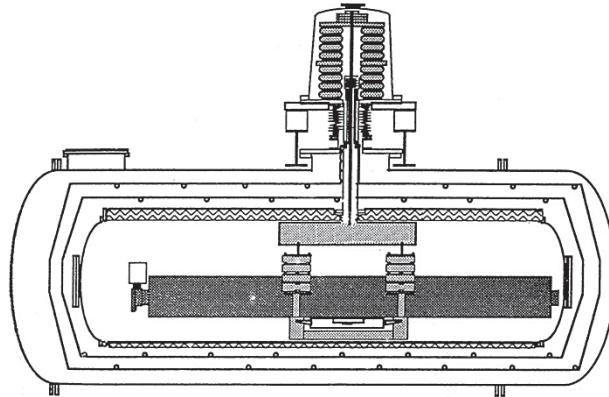

Figure 1. Cross-section of a cryogenic resonant bar detector (NIOBE [14]). The bar is suspended from a multistage vibration isolation system into a cryostat cooled by liquid helium. The transducer and a microwave amplifier are on the left-hand side of the bar.

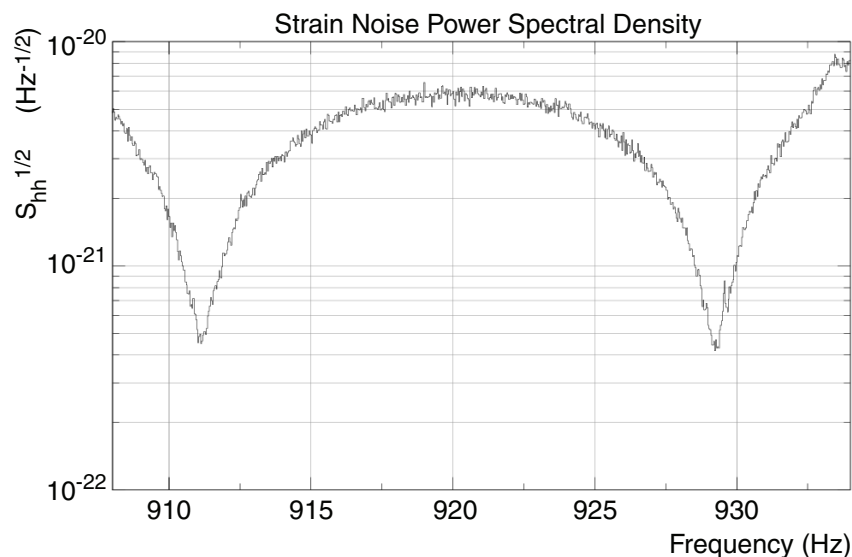

Figure 2. Typical sensitivity curve of a bar detector, in this case the linear spectral density $\sqrt{S_h}$ of the strain noise versus frequency for the first run of the AURIGA detector [18].

AURIGA has operated since 1997 at Legnaro (Padova, Italy). It is a 2230 kg Al antenna cooled to 200 mK. The resonance frequencies are 912 and 930 Hz. The stop forced by a vacuum leakage inside the cryostat in November 1999 was used to improve the performance of the detector by installing a three-mode transducer and a double-stage SQUID together with new suspensions. Preliminary noise curves show a sensitivity better than $3 \times 10^{-21}/\sqrt{\text{Hz}}$ over a bandwidth of 80 Hz and $\tilde{h} \sim 2 \times 10^{-22}/\sqrt{\text{Hz}}$ at the resonances [19].
Homepage: <http://www.auriga.inl.infn.it>

EXPLORER has been operated since 1984 at CERN (Geneva, Switzerland) by the Rome Group. It is a 2270 kg Al antenna cooled to 2.5 K. The resonance frequencies are 905 and 921 Hz.

The detector has performed long-term observations since 1990. In 1999 the antenna was equipped with a new read-out, a rosetta-shaped resonator, allowing a very small gap (10 μ m), and an advanced SQUID. Since May 2000 EXPLORER has started to gather data with a sensitivity of $\tilde{h} \sim 10^{-20}/\sqrt{\text{Hz}}$ and a bandwidth of 55 Hz [20, 21]. The strain noise is $\tilde{h} \sim 3 \times 10^{-21}/\sqrt{\text{Hz}}$ with a bandwidth of 30 Hz. EXPLORER is equipped with cosmic ray detectors in order to study the interaction of cosmic ray showers with the bar via acoustic excitation.

Homepage: <http://www.roma1.infn.it/rog/explorer/>

NAUTILUS has been operated since 1995 at Frascati (Italy) by the Rome Group. It is a 2260 kg Al antenna cooled to 130 mK. Until 2002, the resonance frequencies were 908 and 924 Hz. Now, the detector has just started running again tuned to 935 Hz, the frequency of a possible pulsar as the remnant of SN 1987A. Transducer and amplifier are the same as used for EXPLORER. The sensitivity is $h \sim 2.5 \times 10^{-19}$. The strain noise is $\tilde{h} \sim 2 \times 10^{-21}/\sqrt{\text{Hz}}$ around 935 Hz and $\tilde{h} \leq 10^{-20}/\sqrt{\text{Hz}}$ over about 30 Hz. NAUTILUS is also equipped with cosmic ray detectors [22].

Homepage: <http://www.roma1.infn.it/rog/nautilus/>

NIOBE has operated since 1993 at Perth (Western Australia). It is a 1500 kg niobium antenna cooled to 4.0 K (see figure 1). The resonance frequencies are 695 and 713 Hz. Here, the bar and the secondary mass are made of Nb instead of Al as it has a higher mechanical Q . The vibrational state of the antenna is monitored by a superconducting microwave parametric transducer. The sensitivity is $h \sim 10^{-20}$ in a 70 Hz bandwidth [14]. NIOBE had its last run in 2001.

Homepage: <http://www.gravity.uwa.edu.au/bar/>

3.2. Spherical detectors

Since the 1990s spherical resonant-mass antennas have been investigated. Because of their shape they have omnidirectional antenna patterns. If all five independent fundamental quadrupolar modes of vibration can be monitored, they can do all-sky observations and determine directions as well as verifying detections using coincidences between modes of the same antenna.

MiniGRAIL is being built at Leiden University in the Netherlands. It is a 68 cm diameter sphere made of a CuAl (6%) alloy with a mass of 1300 kg. It has two resonance frequencies, at 2940 Hz and at 3030 Hz. The sphere is suspended by a seven-stage vibration isolation system. The antenna will operate at a temperature of 20 mK; it is equipped with a two-stage SQUID amplifier. The quantum-limited strain sensitivity is expected to be $\tilde{h} \sim 10^{-22}/\sqrt{\text{Hz}}$ at the resonances [23, 24].

Homepage: <http://www.minigrail.nl>

Mario Schenberg is a similar spherical detector, being built at the University of São Paulo (Brazil) [25] in collaboration with MiniGRAIL. It is a 65 cm diameter sphere made of a CuAl (6%) alloy with a mass of 1150 kg. It has a resonance frequency of 3200 Hz and a bandwidth of about 50 Hz [26]. It will be operating in coincidence with MiniGRAIL and Sfera, the spherical detector planned at Rome, Italy.

Homepage: <http://www.das.inpe.br/~graviton>

4. Laser interferometers

A gravitational wave changes the proper distance l between freely falling test masses, and it changes two perpendicular distances by the same amount δl_{gw} , but with different sign, if the

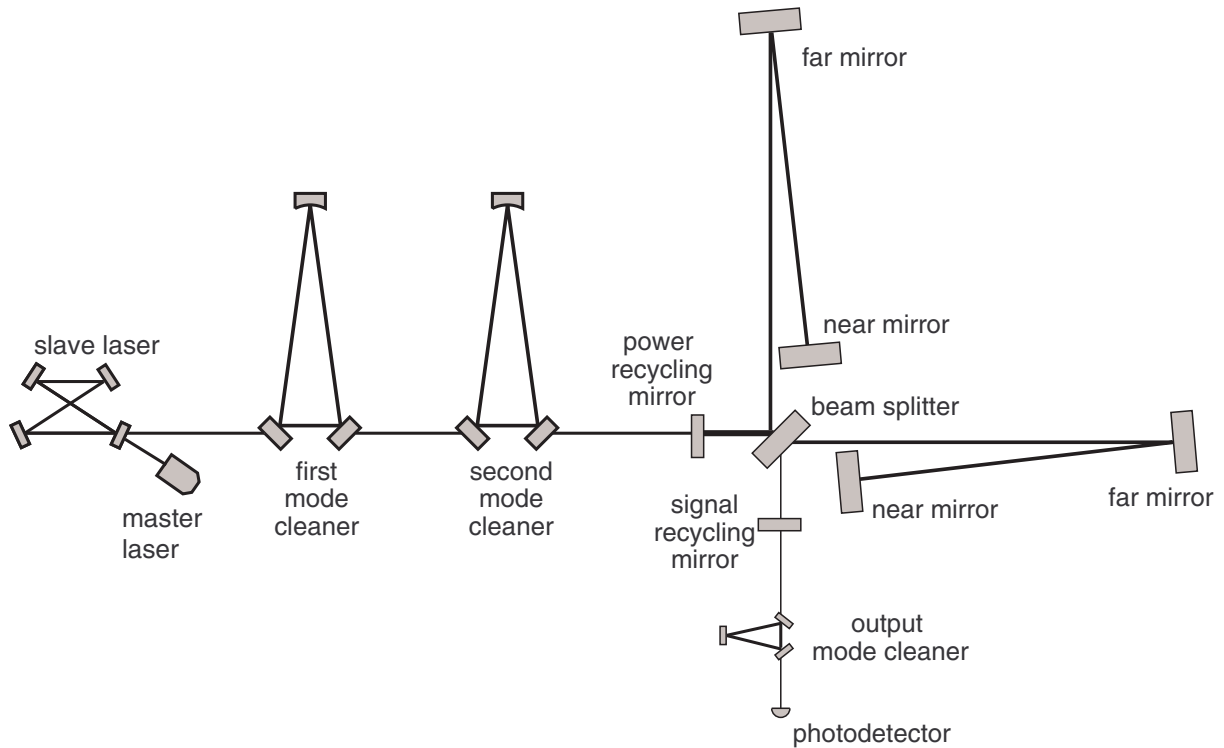

Figure 3. Optical layout of GEO600 as an example of a laser interferometric gravitational wave detector. On the left-hand side, the laser system (master oscillator and slave laser) is shown, then two mode cleaners for the spatial filtering of the laser beam, followed by the dual recycled Michelson interferometer with a four-pass delay line and output mode cleaner.

orientation of the test masses is optimum. If two beams of light travel these distances, the change in l produces a phase shift between them:

$$\delta\phi_{\text{gw}} = \frac{4\pi}{\lambda} \delta l_{\text{gw}}. \quad (9)$$

A Michelson interferometer (figure 3) is the perfect instrument to detect this phase shift as a change in the interference at the output. A detector with an arm length $l = 1$ km responds to a gravitational wave of amplitude $h = 10^{-21}$ with

$$2 \cdot \delta l_{\text{gw}} \sim hl \sim 10^{-18} \text{ m}. \quad (10)$$

The advantage of laser interferometers compared to resonant detectors is the broad detection band, from about 10 Hz to 5 kHz [13].

In practice, the phase difference is monitored by a nulling method: one keeps the light returning from the two arms always 180° out of phase so that the output is dark. The error signals of the automatic control applied to the end mirrors to maintain the dark fringe are directly proportional to the action of the gravitational wave. The sensitivity depends on the arm length and the amount of light energy stored in the arms [27]. In order to increase the storage time, most

interferometers use Fabry-Perot cavities in the arms. Delay-line interferometers store the light by increasing the number of round-trips via multiple reflections (cf figure 3). Both configurations are equivalent in sensitivity [27]. In order to exclude acoustic disturbances and fluctuations in the local index of refraction, the measurements have to be carried out in ultra-high vacuum, at a pressure of $\sim 10^{-7}$ Pa.

The main sources of noise competing with the small amplitude (10) are the following.

Seismic noise. External mechanical vibrations lead to displacements of the mirrors that are many orders of magnitude larger than the expected signal. Vibration isolation systems are a combination of active filters (piezo-electric actuators) and passive filters (alternate layers of steel and rubber) and a multi-stage pendulum suspension of the optical components [28]. A pendulum is a good mechanical filter for frequencies f above its eigenfrequency f_0 ; the suppression is proportional to $(f_0/f)^2$ for a single pendulum stage. By hanging the mirrors on pendulums of about 0.5 m length, filtering above some 10 Hz is achieved with a factor of about 10^7 or 10^8 . Seismic noise is the limiting noise below about 10 Hz.

Thermal noise. As with bar detectors, Brownian motion of the mirrors and excitation of the violin modes of the suspension can mask gravitational waves. The amplitude noise density of surface vibration modes (with frequency f_0) of the test mass is, at gravitational wave frequencies $f_{\text{gw}} \ll f_0$,

$$\delta\tilde{l}_{\text{th}} = \left(\frac{kT}{2\pi^3 M Q f_0^3} \right)^{1/2}. \quad (11)$$

Thus large masses M of a high- Q material ($\sim 10^7$) are required and cooling below 1 K is desirable. Notwithstanding, present-day interferometers are operated at room temperature. Mirror masses are designed to have principal vibration modes above 5 kHz, and pendulum suspensions have frequencies at about 1 Hz—well outside the observing band of initial interferometers. Thermal noise is the limiting noise between 50 and 250 Hz.

Shot noise. Photons arrive at random (with Poissonian distribution) at the photodiode causing random fluctuations of the light intensity, faking apparent fluctuations in the path difference with a spectral density of

$$\delta\tilde{l}_{\text{sn}} = \left(\frac{\hbar c \lambda}{2\pi \eta P} \right)^{1/2}, \quad (12)$$

where η is the efficiency of the photodiode, λ the laser wavelength and P the circulating light power. With a sufficiently powerful laser, one could in principle achieve arbitrarily small $\delta\tilde{l}_{\text{sn}}$. In order to obtain $h = 10^{-22}$, $\eta P \sim 1$ kW is required. Shot noise is the principal limitation to sensitivity for frequencies above about 250 Hz. On the other hand, photons carry momentum and thus exert random forces on the test mass leading to a displacement noise density of

$$\delta\tilde{l}_{\text{rp}} = \frac{1}{M f_{\text{gw}}^2} \left(\frac{\hbar P}{2\pi^3 c \lambda} \right)^{1/2}; \quad (13)$$

this is ‘radiation pressure noise’. To minimize it requires small light power in contrast to the above said. The limiting strain sensitivity is $h_{\text{rp}} \approx 10^{-25}$, therefore the optimal output power can be as large as 1 MW for the present detectors [29]—far beyond the output of any continuous laser.

Gravity gradient noise. Changes in the local Newtonian field act like tidal forces on a gravitational wave detector. This environmental noise comes from human activities, but also from atmospheric pressure changes, clouds, seismic density waves and the surf of the sea. These effects become dominant at low frequencies and are the primary reason why the detection of gravitational waves in the frequency band below 1 Hz must be done in space.

Quantum effects. Shot noise is quantum noise, but there are other fundamental effects like zero-point vibrations of mirror surfaces, etc. The Heisenberg uncertainty principle $\Delta x \Delta p > \hbar$ sets a limit on the measurement of the position of a free mass. For the present-day detectors this corresponds to $h_{\text{qu}} \approx 10^{-25}$.

Michelson-type gravitational wave detectors require a cw laser of unprecedented stability and the largest possible output power (see above). All the projects use a Nd:YAG laser in the form of a non-planar ring oscillator (NPRO). Pumped by laser diodes, they exhibit a high overall efficiency; their good tunability allows efficient stabilization schemes. Today such a laser produces an output power of about 1 W at a wavelength of 1064 nm. This is amplified in a second laser resonator by injection-locking ('master-slave' scheme) [30] or in a combination of master-oscillator/power-amplifier (MOPA) to about 10 or 20 W. This light is coupled into one or two ring resonators (mode cleaners) preparing the TEM₀₀ mode, with a power of about 10 W.

The high light power needed inside the arms of the interferometer is achieved by means of a technique called 'power recycling'. Using the 'dark-fringe' observation mode (no light at the output port) means that all the light is reflected back to the input port, the whole interferometer acting as a low-loss mirror. If one places another mirror between the laser and the beam splitter (cf figure 3), the two mirrors form a resonant cavity adding coherently in phase the reflected light with that emerging from the laser. If the losses are lower than 1%, a 10 W laser is enough to build up an effective power of 1 kW [31].

Five large laser interferometric gravitational wave detectors are in operation, but not yet on a regular basis. All detectors have yet to reach the design sensitivity. Figure 4 shows the improvement in sensitivity during the last few years for the LIGO detectors. The projects in alphabetical order are:

GEO600 has operated since 2001 at Ruthe, near Hannover (Germany) [33]. The British-German collaboration originally planned an interferometer with 3 km arm length, but due to lack of funding, only 600 m could be realized. GEO600 is the first detector to employ the technique of 'signal recycling' to make up for the shorter arms. The idea is similar to that of power recycling: a gravitational wave with frequency f_{gw} produces sidebands $f_L \pm f_{\text{gw}}$, with the laser frequency f_L as carrier. The carrier light goes back to the input port where it can be recycled, but the signal sidebands are produced in anti-phase and leave at the output port. A correctly positioned additional mirror behind the output forms a resonant cavity with the whole interferometer, enhancing the sidebands [31]. By changing the position of the mirror, the interferometer can be tuned to a desired frequency where it is considerably more sensitive in a smaller frequency band. This technique even leads to a moderate reduction of the quantum limit [32].

Another speciality of GEO600 is the monolithic suspension. Normally, the interferometer optics are suspended from fine steel wires; because of friction this leads to additional thermal noise. In GEO600, the wires are fused-silica fibres welded to fused-silica pieces attached at the optics by hydroxide-catalysis bonding. Today, GEO600 has the highest duty cycle (98%) of all operating interferometers [34].

Homepage: <http://www.geo600.uni-hannover.de>

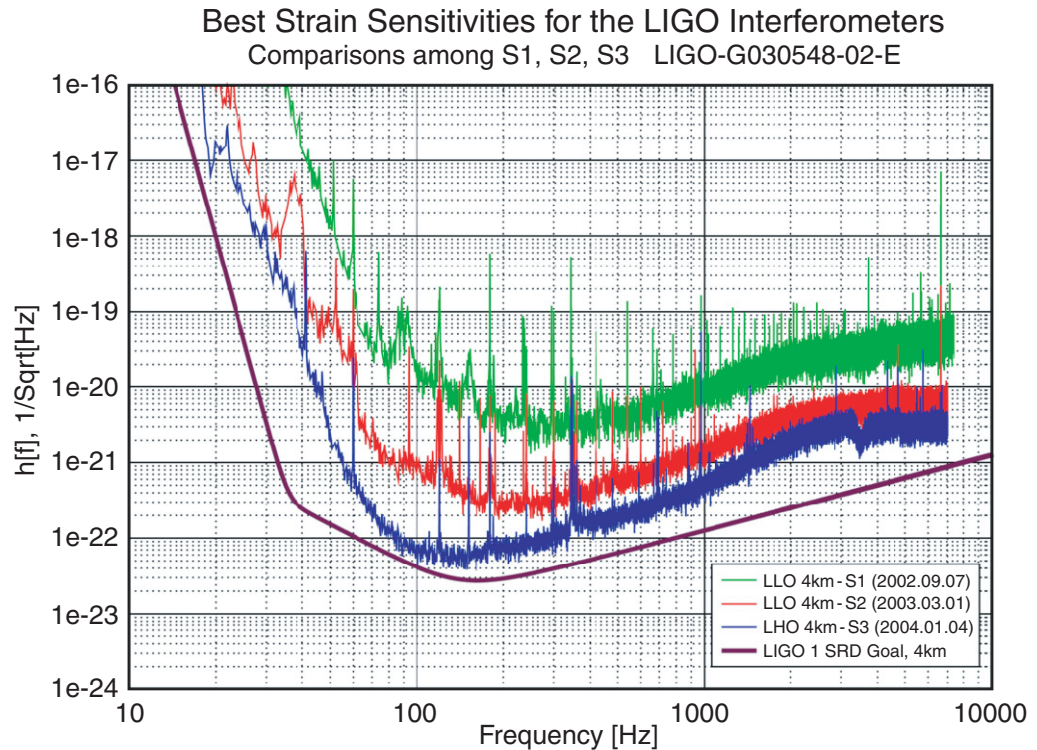

Figure 4. Comparison of the best strain sensitivities \tilde{h} of the LIGO interferometers during the scientific data runs S1 (2002), S2 (2003) and S3 (2004); the lowest curve is the design sensitivity [35].

LIGO (Laser Interferometer Gravitational-Wave Observatory) has operated since 2001 at two sites in the USA, at Hanford (Washington) and Livingston (Louisiana). At both sites, an interferometer with 4 km arm length has been built, and at Hanford an additional one with 2 km in the same vacuum system. The two LIGO detectors are the best-placed for doing coincident observations. The design sensitivity is $\tilde{h} \leq 10^{-22}/\sqrt{\text{Hz}}$ within a frequency band between 60 Hz and 1 kHz [36, 37]. Figure 4 shows how close the LIGO detectors are to their goals.

Homepage: <http://www.ligo.caltech.edu>

TAMA300 has operated since 1999 at Tokyo (Japan). The 300 m arm length interferometer has performed several successful data runs with a total of more than 2000 h. *TAMA300* is, just as *LIGO* and *Virgo*, equipped with standard Fabry–Perot cavities in the arms. The sensitivity is $\tilde{h} \leq 10^{-20}/\sqrt{\text{Hz}}$ within a frequency band between 300 Hz and 8 kHz [38, 39].

Homepage: <http://tamago.mtk.nao.ac.jp>

Virgo will start taking data in 2005 at Cascina, near Pisa (Italy). The French–Italian project has an arm length of 3 km. An elaborate seismic isolation system, the ‘super-attenuator’, consisting of six-stage pendulums, in conjunction with an inverted pendulum and an active isolation stage, will allow measurements down to frequencies of 10 Hz with a similar sensitivity as *LIGO* [40].

Homepage: <http://www.virgo.infn.it>

5. Future detectors

5.1. Resonant detectors

The principal aim of present development work is to get a larger bandwidth. The physical parameters of the antenna (M, l, f_0) and the thermodynamic temperature T are fixed within a given detector. The main limitation comes from transducer and amplifier. Significant improvements of bar detector sensitivity can be achieved by decreasing the electronic noise and increasing the coupling β of the transducer to the SQUID and by increasing Q . An effective bandwidth of about 100 Hz seems possible.

Spherical detectors can have more mass, and thus a smaller quantum limit (8); for the original GRAIL project, a CuAl sphere with a radius of 3 m and a mass of 100 t was planned. This antenna could reach $h \sim 10^{-22}$ at 1 kHz if cooled down to 10 mK [41].

5.2. Interferometers

The next generation of interferometric detectors will use high-power lasers (up to 200 W), massive mirrors of high- Q materials (e.g., sapphire) and cryogenic coolers [42]. All-reflective topologies based on silicon substrates and diffractive beam splitters will eliminate thermal heating caused by absorption. Quantum non-demolition (QND) techniques and squeezed light can beat the quantum limit [43]. Satellite missions allow larger arm lengths (50 000 or 5 million km) and will thus open the mHz frequency band [44].

Advanced LIGO will rely on the existing facilities at the sites of Hanford and Livingston. The four-stage suspensions will be modelled after the GEO600 monolithic pendulum concept, with mirrors made from large substrates of sapphire. Together with seismic isolation systems using inertial sensing and feedback, this will shift the low-frequency edge of the detection band to about 10 Hz. The GEO600 scheme of detuned signal recycling will also be used. With a 180 W laser, Advanced LIGO will have a sensitivity of more than ten times better than that of the initial LIGO detectors and thus observe a more than 1000 times larger volume of the Universe [45]. The first data run is planned for after 2009.

EURO is the future European detector studied by CNRS (France), INFN (Italy), MPG (Germany) and PPARC (UK). A cryogenic detector deep underground with large test masses ($M \sim 100$ kg) of silicon or sapphire is planned. In order to avoid absorption in the beam splitter or mirrors, all-diffractive optics will be implemented. With xylophone signal recycling, a targeted search for known sources with higher sensitivity will be possible. EURO is scheduled for after 2010.

LCGT (Large Cryogenic Gravitational-wave Telescope) will use ultra-cold mirrors with a super-attenuator suspension and a laser with 300 W output power. This Japanese project will be deep inside a mountain, next to the neutrino detector Super-Kamiokande. It consists of two sets of interferometers with 3 km arm length. The design sensitivity is $3 \times 10^{-24}/\sqrt{\text{Hz}}$ at 100 Hz [46]. *CLIO* (Cryogenic Laser Interferometer Observatory) is a 100 m prototype for LCGT using sapphire for mirrors and suspension fibres; the main mirrors are set in cryostats. The design sensitivity is $2 \times 10^{-20} \text{ m}/\sqrt{\text{Hz}}$ at 20 K around 100 Hz [47].

LISA (Laser Interferometer Space Antenna) is a space mission allowing the investigation of the gravitational wave spectrum at very low frequencies (10^{-4} –1 Hz). The European Space

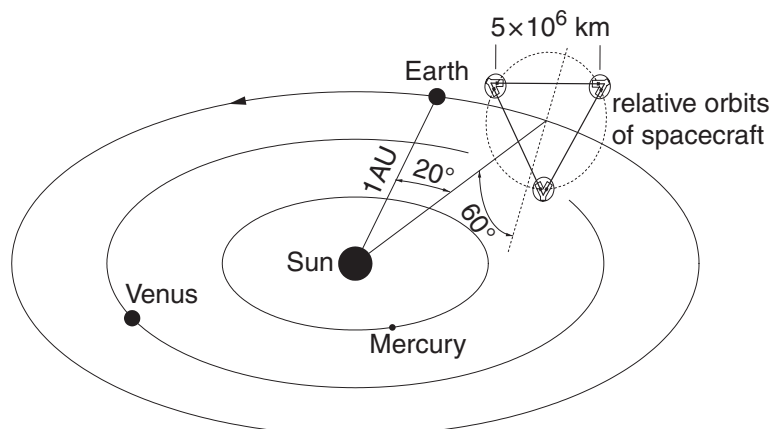

Figure 5. Orbits of the three spacecraft of LISA, trailing the Earth by 20° ; the LISA triangle shown here is amplified by one order of magnitude.

Agency (ESA) and NASA have agreed to collaborate on a project consisting of three identical spacecraft, placed at the corners of an equilateral triangle with a side length of 5 million km (figure 5). This constellation is to revolve around the Sun in an Earth-like orbit, about 20° (i.e. roughly 50 million km) behind the Earth. Each spacecraft has two separate lasers that are phase-locked, so as to represent the beam splitter of a Michelson interferometer. The distances are measured from test masses (Au–Pt alloy cubes) freely floating within the spacecraft. For signals monitored over a considerable fraction of a year, the sensitivity is $h \sim 3 \times 10^{-24}$. LISA is approved by ESA as a cornerstone mission; launch is scheduled for 2013. Some of LISA's essential technologies are to be tested on board a 'LISA Pathfinder' (formerly 'SMART-2') satellite in 2008 [48]. *BBO* (Big Bang Observer) is the plan for a LISA follow-on mission, consisting of four clusters of LISA-like triangles with an arm length of 50 000 km. The clusters are spread over the Earth's orbit, with two clusters at the same place. Such a device will bridge the frequency gap between the terrestrial detectors and LISA.

Homepage (NASA): <http://lisa.jpl.nasa.gov/>

Homepage (ESA): <http://sci.esa.int/home/lisa>

6. International collaborations

Gravitational wave detection forces all the groups worldwide to work together. Only a network of detectors provides accurate information on the observables and gives confidence in a claimed detection. The observables are the amplitude and polarization of the wave, $h_+(t)$ and $h_\times(t)$, and the phase of polarization, $\phi(t)$, further the direction on the sky, θ and φ . This requires at least three detectors to extract all the information.

6.1. IGEC

IGEC (International Gravitational Event Collaboration) was founded on July 4, 1997. All the operating bar detectors participate in this collaboration. The goal of the IGEC is to standardize and simplify the data exchange between the groups and to maintain a continuous discussion on

the data and the analysis procedures. The results of the first analysis of the 1997–2000 data have been published [49]. Within these 1460 days, for 90% of the time one detector was working; there were 707 days with at least two detectors in simultaneous operation, 173 days with at least three detectors and 26 days with at least four detectors. No statistical evidence for detected gravitational waves has been found. A new upper limit has been achieved for the rate of burst events from the Galactic centre, since no signals above 4×10^{-18} have been detected.

6.2. LSC

LSC (LIGO Scientific Collaboration) was founded in 1997 as a forum for organizing research, publications and all other scientific activities in gravitational wave research. At present the LSC comprises about 450 scientists from LIGO, GEO600 and TAMA300. Agreements on data exchange between LIGO, Virgo and GEO600 are being negotiated.

In the fall of 2002, a common data run (S1) between all three LIGO detectors and GEO600 was undertaken consisting of 17 days of mostly uninterrupted operation [50]. With the detectors not yet being at the intended sensitivity level, the aim was rather to rehearse data acquisition and data analysis. Four types of analysis have been performed:

- a search for the inspiral signal from binary neutron star mergers [51],
- a search for continuous waves from a rapidly rotating pulsar [52],
- a search for short bursts of unknown origin [53], and
- a search for the stochastic background of cosmological origin [54].

In all cases new upper limits have been established. A second common data run (S2) was performed in the spring of 2003, lasting for 59 days with the participation of all LIGO detectors, TAMA300 and ALLEGRO. The first preliminary results have been reported [55]. LIGO's third science run (S3) ended in January 2004 after 70 days; GEO600 participated for 3 weeks.

7. Outlook

The present-day generation of gravitational wave detectors is close to the targeted sensitivity. First data runs have been performed and analysed. Up to now, no gravitational waves have been detected, but better upper limits for astrophysical event rates and for the amount of radiation from expected sources have been obtained. With a bit of luck, the direct detection of gravitational waves is possible within the next few years. Otherwise, the second generation of advanced detectors will open the field of gravitational wave astronomy. This could bring us revolutionary insights into the Universe comparable to those brought by radio and x-ray astronomy.

Astronomical observations in recent years [56] have revealed that most of the Universe is composed of dark (exotic) matter (25%) and of negative energy (70%); baryons contribute only 5% of the critical density. Thus by means of electromagnetic radiation, at most 5% of the Universe can be studied directly. Gravitational wave detectors offer a way to observe at least part of this dark sector of our world. Furthermore, detecting the relic background radiation from the Big Bang offers the best possibility to obtain information on the very early Universe, about 10^{-21} s after its creation.

References

- [1] Einstein A 1916 *Sitzungsber. Preuss. Akad. Wiss. Berlin* 688
- [2] Flanagan E E and Hughes S A 2005 *New J. Phys.* **7** 204
- [3] Einstein A 1918 *Sitzungsber. Preuss. Akad. Wiss. Berlin* 154
- [4] Weber J 1960 *Phys. Rev.* **117** 306
- [5] Weber J 1969 *Phys. Rev. Lett.* **22** 1320
- [6] Weber J 1970 *Phys. Rev. Lett.* **25** 180
- [7] Hulse R A and Taylor J H 1975 *Astrophys. J.* **195** L51
- [8] Weisberg J M and Taylor J H 2003 *Radio Pulsars* ed M Bailes, D J Nice and S E Thorsett (*ASP Conf. Ser.* 302) p 93
- [9] Schutz B F and Ricci F 2001 *Gravitational Waves* ed I Ciufolini, V Gorini, U Moschella and P Fré (Bristol: Institute of Physics) p 15
- [10] Ju L and Blair D G 1996 *Int. J. Mod. Phys. D* **5** 101
- [11] Ricci F and Brillat A 1997 *Ann. Rev. Nucl. Part. Sci.* **47** 111
- [12] Misner C W, Thorne K S and Wheeler J A 1973 *Gravitation* (San Francisco: Freeman)
- [13] Saulson P R 1994 *Fundamentals of Interferometric Gravitational Wave Detectors* (Singapore: World Scientific)
- [14] Blair D G, Heng I S, Ivanov E N and Tobar M E 1998 *Gravitational Waves* ed E Coccia, G Pizzella and G Veneziano (Singapore: World Scientific) p 127
- [15] Astone P 2002 *Class. Quantum Grav.* **19** 1227
- [16] Fafone V 2004 *Class. Quantum Grav.* **21** S377
- [17] Heng I S, Daw E, Giaime J, Hamilton W O, McHugh M P and Johnson W W 2002 *Class. Quantum Grav.* **19** 1889
- [18] <http://www.auriga.inl.infn.it/auriga/detector/run1/sensitivity.html> (2004)
- [19] <http://www.auriga.inl.infn.it/cgi-bin/SP2/YaBB.cgi?board=run2> (2004)
- [20] Astone P *et al* 2002 *Class. Quantum Grav.* **19** 1905
- [21] Astone P *et al* 2003 *Phys. Rev. Lett.* **91** 111101
- [22] Astone P *et al* 2002 *Class. Quantum Grav.* **19** 1911
- [23] de Waard A, Gottardi L and Frossati G 2002 *Class. Quantum Grav.* **19** 1935
- [24] de Waard A *et al* 2004 *Class. Quantum Grav.* **21** S465
- [25] Aguiar O D *et al* 2002 *Class. Quantum Grav.* **19** 1949
- [26] Aguiar O D *et al* 2004 *Class. Quantum Grav.* **21** S457
- [27] Mizuno J 1995 *PhD Thesis* Universität Hannover (MPQ Report 203)
- [28] Rüdiger A *et al* 1992 *Lecture Notes in Physics* **410** 239
- [29] Caves C M 1982 *Phys. Rev. D* **26** 1817
- [30] Zawischa I *et al* 2002 *Class. Quantum Grav.* **19** 1775
- [31] Meers B J 1988 *Phys. Rev. D* **38** 2317
- [32] Harms J, Chen Y, Chelkowski S, Franzen A, Vahlbruch H, Danzmann K and Schnabel R 2003 *Phys. Rev. D* **68** 042001
- [33] Willke B *et al* 2002 *Class. Quantum Grav.* **19** 1377
- [34] Willke B *et al* 2004 *Class. Quantum Grav.* **21** S417
- [35] <http://www.ligo.caltech.edu/~lazz/distribution/LSC Data/> (2004)
- [36] Sigg D 2002 *Class. Quantum Grav.* **19** 1429
- [37] Sigg D 2004 *Class. Quantum Grav.* **21** S409
- [38] Ando M *et al* 2002 *Class. Quantum Grav.* **19** 1409
- [39] Takahashi R 2004 *Class. Quantum Grav.* **21** S403
- [40] Acernese F *et al* 2004 *Class. Quantum Grav.* **21** S385
- [41] Frossati G 1996 *The Seventh Marcel Grossmann Meeting* ed R T Jantzen and G M Keiser (Singapore: World Scientific) p 1477
- [42] Giazotto A and Cella G 2004 *Class. Quantum Grav.* **21** S1183

- [43] Schnabel R, Harms J, Strain K A and Danzmann K 2004 *Class. Quantum Grav.* **21** S1045
- [44] Harry G M, Houser J L and Strain K A 2002 *Phys. Rev. D* **65** 082001
- [45] Weinstein A 2002 *Class. Quantum Grav.* **19** 1575
- [46] Uchiyama T 2004 *Class. Quantum Grav.* **21** S1161
- [47] Miyoki S *et al* 2004 *Class. Quantum Grav.* **21** S1173
- [48] Danzmann K and Rüdiger A 2002 *Rev. Mod. Astron.* **15** 211
- [49] Astone P *et al* 2003 *Phys. Rev. D* **68** 022001
- [50] Abbott B *et al* 2004 *Nucl. Instrum. Methods Phys. Res. A* **517** 154
- [51] Abbott B *et al* 2004 *Phys. Rev. D* **69** 122001
- [52] Abbott B *et al* 2004 *Phys. Rev. D* **69** 082004
- [53] Abbott B *et al* 2004 *Phys. Rev. D* **69** 102001
- [54] Abbott B *et al* 2004 *Phys. Rev. D* **69** 122004
- [55] Riles K 2004 *APS Meeting* (Denver, 1–4 May)
- [56] Spergel D N *et al* 2003 *Astrophys. J. Suppl.* **148** 175