

## Measurement of the non-reciprocal phase noise of a polarization maintaining single-mode optical fiber

This content has been downloaded from IOPscience. Please scroll down to see the full text.

2009 J. Phys.: Conf. Ser. 154 012022

(<http://iopscience.iop.org/1742-6596/154/1/012022>)

View [the table of contents for this issue](#), or go to the [journal homepage](#) for more

Download details:

IP Address: 194.95.157.184

This content was downloaded on 05/05/2017 at 08:35

Please note that [terms and conditions apply](#).

You may also be interested in:

[Lasers for LISA: Overview and phase characteristics](#)

M Tröbs, S Barke, J Möbius et al.

[Precision laser development for interferometric space missions NGO, SGO, and GRACE Follow-On](#)

K Numata and J Camp

[Picometer interferometry for the LISA gravitational reference sensor](#)

Thilo Schuldt, Martin Gohlke, Dennis Weise et al.

[Non-Reciprocal Microwave Junctions and Circulators](#)

A J Rogers

[Interferometry for LISA and LISA Pathfinder](#)

A F García Marín, G Heinzl and K Danzmann

[Generation and Detection of Squeezed Light with Phase Tunable Fiber Loop Mirror using Polarization Beam Splitter](#)

Norihiko Nishizawa, Masaki Hashiura, Takeo Horio et al.

[Experimental performance of a single-mode Yb-doped fiber ring laser](#)

K Numata and J Camp

[Fiber modulators and fiber amplifiers for LISA](#)

M Tröbs, S Barke, J Möbius et al.

[A low-frequency vibration insensitive pendulum bench based on translation-tilt compensation in measuring the performances of inertial sensors](#)

L Liu, X Ye, S C Wu et al.

# Measurement of the non-reciprocal phase noise of a polarization maintaining single-mode optical fiber

Roland Fleddermann<sup>1</sup>, Frank Steier<sup>1</sup>, Michael Tröbs<sup>1</sup>,  
Johanna Bogenstahl<sup>2</sup>, Christian Killow<sup>2</sup>, Gerhard Heinzl<sup>1</sup> and  
Karsten Danzmann<sup>1</sup>

<sup>1</sup> Albert-Einstein-Institute Hanover, Max Planck Institute for Gravitational Physics and  
Leibniz University Hanover, Callinstr. 38, D-30167 Hannover, Germany

<sup>2</sup> Department of Physics and Astronomy, University of Glasgow, Glasgow G12 8QQ, UK

E-mail: Roland.Fleddermann@aei.mpg.de

**Abstract.** Polarization maintaining single-mode optical fibers are key components in the interferometry of the Laser Interferometer Space Antenna (LISA). LISA's measurement principle relies on the availability of space qualified fibers of this type which influence the phase of light with a wavelength of 1064 nm passing in opposite directions through them with differences smaller than  $6 \mu\text{rad}/\sqrt{\text{Hz}}$ . We present a measurement scheme suitable to sense these non-reciprocal phase changes, as well as results obtained using this setup on samples of commercially available fibers. The experimental setup for the fiber characterization consists of a quasi-monolithic interferometer which constitutes a representative cut-out of the local interferometry on-board LISA concerning the fiber. Several noise sources are identified and improvements to the setup are presented to overcome them. The noise level achieved using this setup is between approximately  $40 \mu\text{rad}/\sqrt{\text{Hz}}$  and  $400 \mu\text{rad}/\sqrt{\text{Hz}}$  in the frequency range between 1 mHz and 1 Hz. It is also verified that this noise level is limited by the setup and not introduced by the fiber.

## 1. Introduction

The Laser Interferometer Space Antenna (LISA) [1–3] requires optical fibers as key components for the mission. These fibers are foreseen in the current LISA baseline design, since a flexible optical connection within the interferometric path is desired. The angle between the satellites deviates periodically during one year from its nominal value of  $60^\circ$  by up to  $1.5^\circ$  while the constellation moves around the Sun [4, 5]. Therefore, the direction of the light beams sent out from the spacecraft has to be changed. This is to be accomplished by changing the angle between two individual optical benches inside each satellite. Fibers are the most promising candidates for the task of connecting the two moving optical benches.

Currently there are several experiments going on in research institutes all over the world to measure the reciprocity of optical fibers, among them the University of Florida, University of Glasgow and the Jet Propulsion Laboratory.

In the application on-board LISA non-reciprocal phase changes in the fiber cannot be distinguished from distance changes between the test masses whose position is to be measured with picometer sensitivity. Hence we measure the non-reciprocal phase noise of such fibers in order to verify that this noise source does not spoil the measurement performance. Reciprocal noise is expected as well, but this does not have to be taken into account, because it can

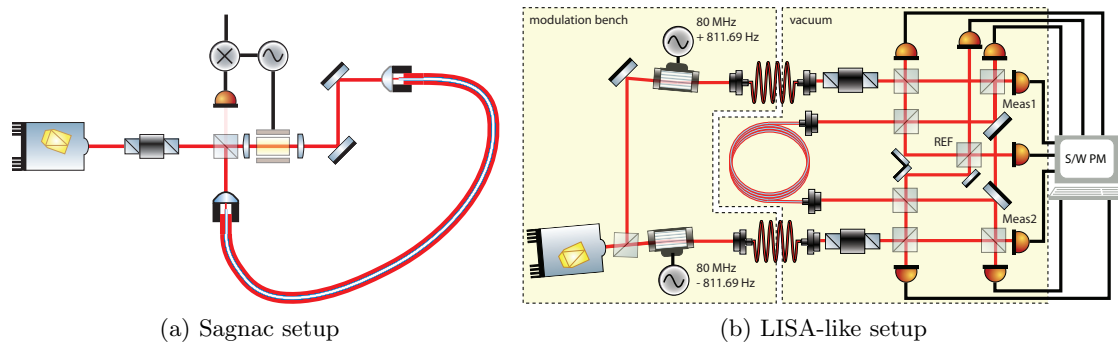

Figure 1: Two different optical setups used for the measurement of the non-reciprocal phase noise of optical fibers.

be subtracted by a technique called Time Delay Interferometry (TDI) [6, 7] during data post processing.

Non-reciprocal phase noise must be smaller than the required phase sensitivity of LISA which is  $6 \mu\text{rad}/\sqrt{\text{Hz}}$ . To accomplish the task of measuring this phase noise a measurement setup with an inherent non-reciprocity of about one order of magnitude below this level is required.

## 2. Experimental setup

Two alternative optical setups have been evaluated for the measurement of the non-reciprocal phase noise.

At first it was believed that the easiest way is to measure the non-reciprocal phase noise using a Sagnac interferometer. A Sagnac interferometer is to first order exclusively sensitive to non-reciprocal phase changes [8,9]. Therefore, it seemed to be an ideal tool for the characterization of the fiber.

This setup has the advantage of being relatively simple. Furthermore, due to the reciprocity of the setup, coupling of path length fluctuations and laser frequency noise to the phase are largely eliminated. The main disadvantage of the setup is that a heterodyne phase readout is not possible and hence additional components are needed to improve the sensitivity.

The alternative is a setup resembling the situation on-board a LISA spacecraft. It has the advantage that a heterodyne measurement can be performed. An even bigger advantage is that the interferometer layout is a representative copy of the fiber interferometry on-board LISA which offers the opportunity to characterize not only the fiber, but also other important aspects that are due to the interferometer design. Disadvantages are that the setup is more complex and that path length and laser frequency changes couple into the non-reciprocal phase observed.

First experiments were conducted using the Sagnac setup shown in Figure 1a. Here, the light of a Nd:YAG laser (Innolight Mephisto 500) is split by a beamsplitter. Both beams are then sent through a fiber such that after passing through the fiber they interfere at the same beamsplitter where the beam was split. An electro-optical modulator (EOM) is introduced close to one end of the fiber to allow for a non-reciprocal modulation which results in a better sensitivity to small non-reciprocal phase changes.

Unfortunately it turned out that the sensitivity of this setup was limited to about  $5 \text{ mrad}/\sqrt{\text{Hz}}$  to  $10 \text{ mrad}/\sqrt{\text{Hz}}$  in the frequency range between 1 mHz and 100 mHz and that this noise level could not be improved although a lot of noise hunting was done. Therefore, the Sagnac setup is not detailed here further and the following discussions are focused on the LISA-like setup.

Figure 1b shows the basic LISA-like setup. In this setup, the light of one Nd:YAG laser is split into two beams by a power beamsplitter. Both fractions are then sent through acousto-

optical modulators (AOMs) working at slightly different frequencies, namely  $80\text{ MHz} + 811.69\text{ Hz}$  and  $80\text{ MHz} - 811.69\text{ Hz}$ , resulting in a frequency difference between the two output beams of  $1.623\text{ kHz}$ . These beams are launched into the optical bench containing the interferometers, which are thus used in a heterodyne scheme. This part of the setup is called modulation bench.

The optical bench itself consists of three individual interferometers which are used in combination to measure the non-reciprocal phase changes in the fiber under test.

In the reference interferometer, labeled REF in Figure 1b, both beams are directly routed to the interference beamsplitter. The measured phase of this interferometer is used for subtraction of the pathlength changes on the modulation bench which are common-mode in all interferometers. In the first measurement interferometer, Meas1, the first beam is traveling directly to the interference beamsplitter, while the second beam passes through the fiber on its way to this point. The situation in the second measurement interferometer, Meas2, is exactly opposite. Here, the second beam travels directly to the beamsplitter, while the first beam passes through the fiber.

Thus the reciprocal phase changes are measured in the two measurement interferometers, Meas1 and Meas2, in opposite directions. The non-reciprocity can now be found by comparison of the changes in the phases measured in both interferometers. Photodiodes at the corresponding beamsplitters sense the beat signal at the heterodyne frequency of  $1.623\text{ kHz}$ . Its phase is measured with a software phasemeter implemented on a PC like the one described in [10, 11].

### 3. Noise hunting

Initial measurements using the LISA-like setup described in the previous section were performed using an interferometer based on an aluminum baseplate. These measurements showed a relatively high non-reciprocal noise level. This can be seen in the corresponding trace in Figure 2. The non-reciprocal noise has a magnitude of about  $100\text{ mrad}/\sqrt{\text{Hz}}$ , decreasing with  $1/f$  to higher frequencies.

In the following paragraphs the noise hunting that was performed on the setup is described stepwise. The topic under investigation is emphasized at the beginning of each paragraph.

*Quasi-monolithic setup* Investigations soon suggested that the non-reciprocity was introduced by length changes in the part of the setup where the two beams sensing the fiber do not travel through the same path. Non-homogenous thermal expansion of the baseplate is most likely to be the limiting noise source.

To overcome these limitations a revised version of the interferometer has been devised which is optimized for the application in a Zerodur<sup>®</sup> baseplate interferometer. This material has been chosen because of its very low coefficient of thermal expansion of approximately  $10^{-7}/\text{K}$ . Small modifications that were necessary for the construction of a quasi-monolithic interferometer have been added to the setup in comparison to the one based on aluminum.

The interferometer was built using the hydroxide-catalysis bonding technique [12–14]. Due to the challenging alignment of the interferometer, some components (BS6, BS7 and M||) were added to the initial setup from Figure 1b for simplification of construction.

The most important change compared to the initial setup is an additional null-measurement path via BS5 and BS6 that is confined to the Zerodur<sup>®</sup> baseplate and thus allows for characterization of the instrument sensitivity without the fiber.

The results of the first measurement using this setup are represented by the corresponding trace in Figure 2. It is evident that only a very small improvement with respect to the aluminum setup is achieved. Therefore, further investigations have been undertaken to identify the limiting noise source.

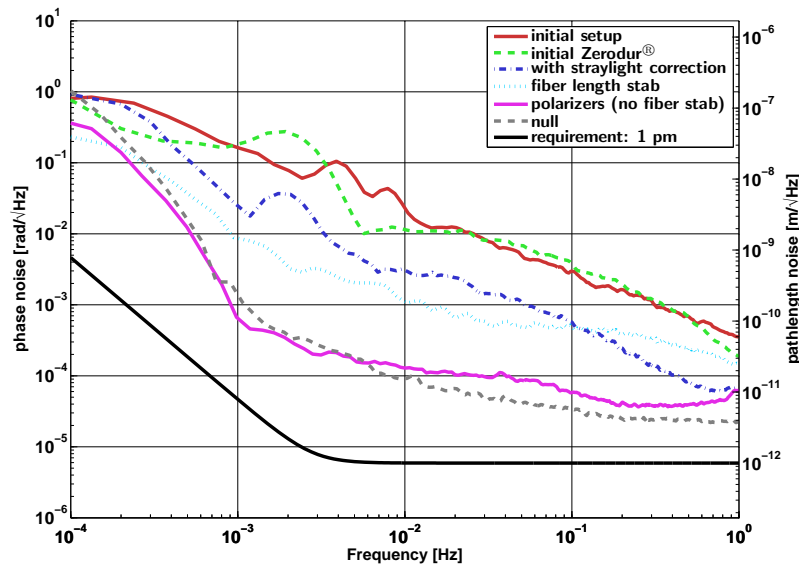
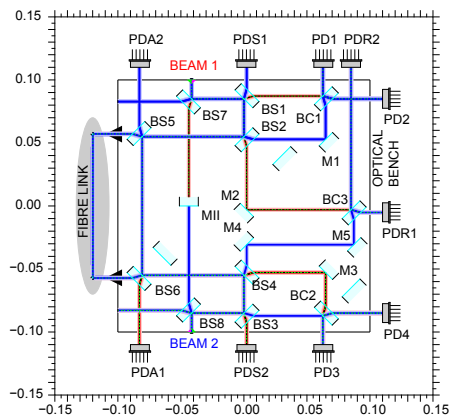
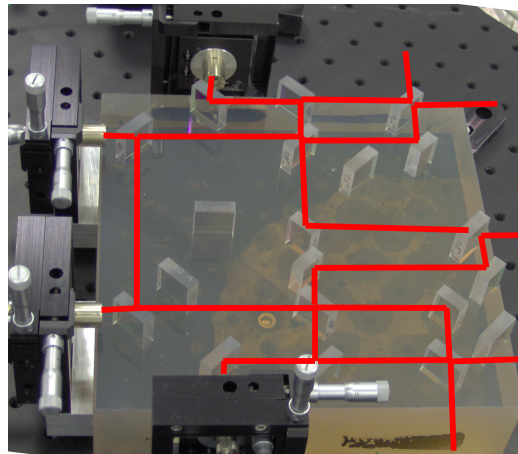

Figure 2: Non-reciprocal path length noise spectral densities observed using different improved versions of the LISA-like setup for the fiber characterization.



(a) Schematic created using OptoCad [15]



(b) Actual setup

Figure 3: LISA-like setup optimized for Zerodur® baseplate

*Stray light* It was apparent, that some light was reflected by either the fiber under test or the fiber coupler assemblies. This back-reflected light cannot be blocked because it travels along the same beam axis or is even in the same spatial mode as the counter propagating beam when it originates from a reflection occurring inside the fiber. The reflected light led to a spurious interference signal at the two measurement interferometers. This is exactly what happens at the fiber link on-board LISA: The beam coming from the fiber interferes with the beam entering it at the point where the entering beam is back-reflected.

Therefore, a stray light correction scheme was applied to remove this influence from the

measured phase. The principle of this correction is based on phase measurement at both outputs of the interference beamsplitter [16]. It relies on the fact that the phase difference of the interference signals is  $180^\circ$  between both beamsplitter outputs while scattered light which has interfered in another place of the setup will have zero phase difference in both outputs.

This scheme was implemented in data post processing. It led to a significant reduction of the observed non-reciprocal phase noise as can be seen by comparing the trace in Figure 2 which represents the phase noise observed with scattered light correction to the trace which is not corrected for scattered light. The correction leads to a reduction of non-reciprocal noise by about one order of magnitude. This shows, that a significant amount of the noise observed at that point could be attributed to back-reflected light. Therefore, it was decided to use the stray light correction for all further measurements.

This is very valuable information for the design of the LISA optical benches. The fiber link part of the current baseline design of the LISA optical benches closely resembles the setup that was used here, so it might be necessary to implement a similar correction for LISA.

*Fiber length stabilization* In a next step a fiber length stabilization was implemented. This seemed necessary as observations showed that the phase observed at both ends of the fiber changed by up to hundred radians during one night. It was feared that this high reciprocal phase noise would couple to the observed non-reciprocal phase noise of about  $100 \mu\text{rad}$  due to a limited “common-mode rejection” of the fiber.

The fiber length stabilization was implemented by gluing the fiber to a ring piezo [17]. The piezo was driven by a feedback control loop that used the difference between the phase at one end of the fiber and the phase of the reference interferometer as error signal.

The results of this measurement are represented by the respective trace in Figure 2. A comparison to the previous trace without fiber length stabilization shows that the fiber length stabilization reduced the non-reciprocal noise at frequencies below 100 mHz, while for frequencies above, the noise is slightly amplified. This led to the assumption that the method of stabilization had an effect on polarization maintaining properties of the fiber. This would then lead to a change in the output polarization of the fiber which in turn would appear to be non-reciprocal phase changes due to changing content of light in the interference signal.

*Polarization* It was therefore decided to add polarizers in front of both fiber ends. If the input light polarization axis does not match the fiber axis, light propagates through the fiber in both perpendicular polarization states. As the fiber is made deliberately birefringent in order to be polarization maintaining, the light in the two polarization states will generally experience different phase shifts. A change in the fiber axis or in the refractive index of one axis through external influences like e.g. pressure or temperature will therefore lead to phase changes at the output of the fiber which are not necessarily reciprocal.

The results of this measurement are found in the corresponding trace in Figure 2. It is obvious that the introduction of the polarizers led to a significant reduction in observed non-reciprocal phase noise. The noise curve is about one order of magnitude below the one recorded without the polarizers. It is worth noting that this result was achieved even without stabilizing the length of the fiber.

This noise observed using polarizers in the setup is also very close to the noise that was observed when the fiber was removed and a null-measurement was performed. This measurement was done to monitor the inherent non-reciprocity of the measurement setup. From the fact that the noise curve without the fiber is identical to the noise curve with the fiber in place within the limits of variations between repeated measurements, it can be deduced that no significant additional noise is introduced by the fiber but that instead the currently observed noise level is

limited by the setup. This means that to overcome this limit a redesign of the setup might be necessary. Investigation of the critical parameters is currently underway.

#### 4. Conclusions and outlook

We presented a possible setup for the investigation of non-reciprocal fiber phase noise as well as first results obtained using this setup. The results do not yet meet the requirements but they are very close to them in the frequency range between 100 mHz and 1 Hz. It has also been shown that this phase noise is inherent to the setup and that no extra non-reciprocal phase noise is introduced by the fibers under investigation.

To achieve the current sensitivity, a technique has been successfully employed to subtract the phase noise that is caused by reflections. This led to a significant reduction of the observed non-reciprocal phase noise. Another significant improvement of the sensitivity was achieved by fixing the polarization state and aligning it to the fibers. Due to the similarity of the setup that was used here to the LISA setup this is valuable information for the LISA optical bench design.

Further investigations are required to identify the limiting noise source of the current setup. Several external influences will have to be studied in more detail. Depending on the results a redesign of the interferometer setup will be necessary.

This redesigned interferometer might also offer the opportunity to test more realistic space qualified fiber launchers with respect to their influence on the non-reciprocal phase noise.

#### Acknowledgments

We gratefully acknowledge support by Deutsches Zentrum für Luft- und Raumfahrt (DLR) (reference 50 OQ 0601).

#### References

- [1] Hammesfahr A 2001 *Class. Quantum Grav.* **18** 4045–4051
- [2] Bender P *et al.* 1998 LISA. Laser Interferometer Space Antenna for the detection and observation of gravitational waves. An international project in the field of Fundamental Physics in Space. Pre-Phase A report Tech. rep. Max-Planck-Institut für Quantenoptik Garching, Germany
- [3] Danzmann K and Rüdiger A 2003 *Class. Quantum Grav.* **20** 1–9
- [4] Hughes S P 2005 *Advances in Astronautical Sciences* vol 111 ed Culp R D and Jolly S D p 61
- [5] Guangyu L, Zhaohua Y, Heinzel G, Rüdiger A, Jennrich O, Li W, Xia Y, Fei Z and Haibin Z 2008 *International Journal of Modern Physics D* **17** 1021–1042
- [6] Tinto M, Shaddock D A, Sylvestre J and Armstrong J W 2003 *Physical Review D* **67** 122003
- [7] Shaddock D A, Ware B, Spero R E and Vallisneri M 2004 *Phys. Rev. D* **70** 081101
- [8] Arditty H J and Lefèvre H 1981 *Optics Letters* **6** 401–403
- [9] Arditty H J and Lefèvre H 1982 *Fiber-Optic Rotation Sensors and related Technologies* ed Ezekiel S and Arditty H (Springer Verlag New York) pp 44–51
- [10] Heinzel G *et al.* 2004 *Classical and Quantum Gravity* **21** 581–587 URL <http://stacks.iop.org/0264-9381/21/S581>
- [11] Wand V, Guzmán F, Heinzel G and Danzmann K 2006 *AIP Conf. Proc.* **873**(1) 689–696 URL <http://link.aip.org/link/?APCPCS/873/689/1>
- [12] Gwo D H 1998 *Cryogenic Optical Systems and Instruments VIII* vol 3435 ed Heaney J B and Burriesci L G (SPIE) pp 136–142 URL <http://link.aip.org/link/?PSI/3435/136/1>
- [13] Elliffe E J *et al.* 2005 *Classical and Quantum Gravity* **22** S257–S267 URL <http://stacks.iop.org/0264-9381/22/S257>
- [14] Reid S, Cagnoli G, Elliffe E, Faller J, Hough J, Martin I and Rowan S 2007 *Physics Letters A* **363**(5-6) 341–345
- [15] Schilling R 2002 Optocad internal note
- [16] Shaddock D 2007 Scattered light phase error cancellation by balanced detection private communication
- [17] García Marín A F 2007 *Minimisation of optical pathlength noise for the detection of gravitational waves with the spaceborne laser interferometer LISA and LISA Pathfinder* Dissertation Gottfried Wilhelm Leibniz Universität Hannover