

## Finite element analysis regarding the forming behaviour of symmetric hybrid structures consisting of two sheet metal outer layers and a thermoplastic core

This content has been downloaded from IOPscience. Please scroll down to see the full text.

2017 IOP Conf. Ser.: Mater. Sci. Eng. 179 012004

(<http://iopscience.iop.org/1757-899X/179/1/012004>)

View [the table of contents for this issue](#), or go to the [journal homepage](#) for more

Download details:

IP Address: 194.95.157.184

This content was downloaded on 25/04/2017 at 09:52

Please note that [terms and conditions apply](#).

You may also be interested in:

[A staggered coupling strategy for the finite element analysis of warm deep drawing process](#)

J M P Martins, P M Cunha, D M Neto et al.

[Finite element analysis and die design of heading processes of magnesium alloy screws](#)

Y M Hwang and C Y Chang

[Advanced solid elements for sheet metal forming simulation](#)

Vicente Mataix, Riccardo Rossi, Eugenio Oñate et al.

[Analysis of large sheet metal tailored tubes](#)

V M Pomazan

[Advances in characterization of sheet metal forming limits](#)

Thomas B. Stoughton, John E. Carsley, Junying Min et al.

[Including die and press deformations in sheet metal forming simulations](#)

Johan Pilthammar, Mats Sigvant and Sharon Kao-Walter

[Finite element analysis of a composite crash box subjected to low velocity impact](#)

M S I Shaik Dawood, A L Ahmad Ghazilan and Q H Shah

[Numerical Tool Path Optimization for Conventional Sheet Metal Spinning Processes](#)

Benedikt Rentsch, Niko Manopulo and Pavel Hora

[An interpolation type anisotropic yield function and its application in sheet metal forming simulation](#)

R Q Xiao, F Peng and X H Dong

# Finite element analysis regarding the forming behaviour of symmetric hybrid structures consisting of two sheet metal outer layers and a thermoplastic core

B-A Behrens<sup>1</sup>, A Bouguecha<sup>1</sup>, C Bonk<sup>1</sup>, H Schulze<sup>1,2</sup>

<sup>1</sup> Institute of Forming Technology and Machines, Leibniz Universität Hannover, An der Universität 2, 30823 Garbsen

<sup>2</sup> E-mail: schulze@ifum.uni-hannover.de

**Abstract.** To face challenges like damping effects or weight reduction in the automotive sector, new hybrid material combinations are developed. One possibility is the combination of several symmetric material layers with varying material characteristics to achieve in the component production less weight and appropriate stiffness in comparison to components produced with sheet metal. This article deals with the characterization of deep drawing behaviour of layered sandwich structures. The behaviour of the several layers and the layer interaction have been taken into account for the technical design of a deep drawing process. A material layer characterization is performed. Instabilities as interlaminar failures, ruptures or wrinkling of the structure have been investigated as part of additional experimental characterization tests on the basis of various deep drawing process parameters. Finally, the experimental data is used as input for the numerical modelling and simulation of layered structures. The FE simulation includes the material behaviour of the layers and layer interactions with cohesive zone modelling. Based on the results an important contribution for prediction accuracy in the numerical simulation has been provided.

## 1 Introduction

The development of new materials is one approach to face the challenges in the lightweight sector. By the concept of symmetrical sandwich structures different materials with varying behaviour are combined. In this paper a symmetric sandwich structure with outer sheet metal layers with a thickness of  $s_0 = 0.25$  mm and a polymer core ( $s_0 = 0.7$ ) is used for the investigations. To achieve a precise description of the behaviour for the sandwich structure the sheet metal and the polymer core are characterized separately. In addition delamination tests for the sandwich structure are carried out.

## 2 Material characterization

The sheet metal layer in of 0.25 mm thickness was characterized with different test procedures. In order to obtain the flow curves and the anisotropic parameters for the material, quasi-static tensile tests with cut-out sample configurations in the three directions 0°, 45° and 90° according to EN ISO 6892-1 were carried out. For an accurate description of the material hardening behaviour, the characteristics of the sheet metal at high strains are required. For the FE analysis the true stress - true strain curve



determined in the uniaxial tensile test needs to be extrapolated beyond the point of the uniform elongation. Using an inadequate extrapolation process an inaccurate description of the material behaviour at high strain can occur. To ensure a realistic description of the flow behaviour at high strains the hydraulic bulge test according to DIN ISO 16808 is used and the deformation of the blank is continuously measured with an optical system [1], [2].

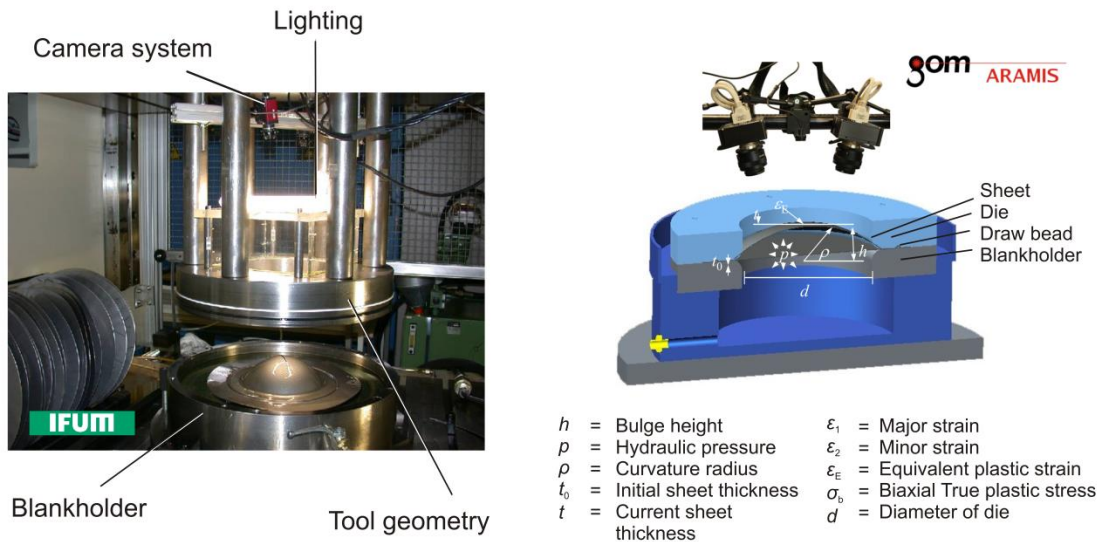

**Figure 1.** Experimental set-up (left) and functional sketch (right) for biaxial bulge test.

In figure 1 on the left side the experimental set-up and a schematic sketch regarding the realization of the hydraulic bulge set-up are shown. The tool consisting of die, blankholder, pressure chamber and pressure load cell is integrated in a hydraulic forming machine. The sheet is clamped between blankholder and die and the material flow is prevented by a draw bead. The displacement of chosen material points on the sheet surface are recorded with the optical measurement system Aramis by the company GOM mbH with a stochastic and continuous grid and the hydraulic pressure in the center of the pressure chamber is measured as well. The biaxial true stress - true plastic strain curve from the bulge test at room temperature was transformed to the uniaxial stress state with a mathematical approach based on the principle of the equivalence of plastic work [3].

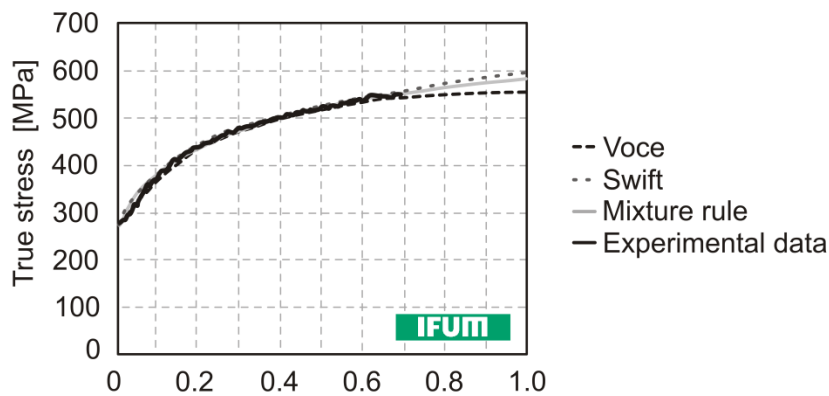

**Figure 2.** True stress - True plastic strain curve for sheet metal HC220 with thickness 0.25 mm, see also [4].

In figure 2 the true stress - true plastic strain behaviour for the sheet metal HC220 is shown with different extrapolation approaches, see also [4]. In addition to the material characterization of the sandwich structure investigations for the polymer layer are carried out. In this case the samples cutted from the sandwich structure are modified. Via die sinking both sheet metal layers are removed and the samples are used for tensile tests at room temperature with the dilatometer DIL 805A/D+T from TA Instruments, formerly Bähr GmbH. Different strain rates were taken into account.

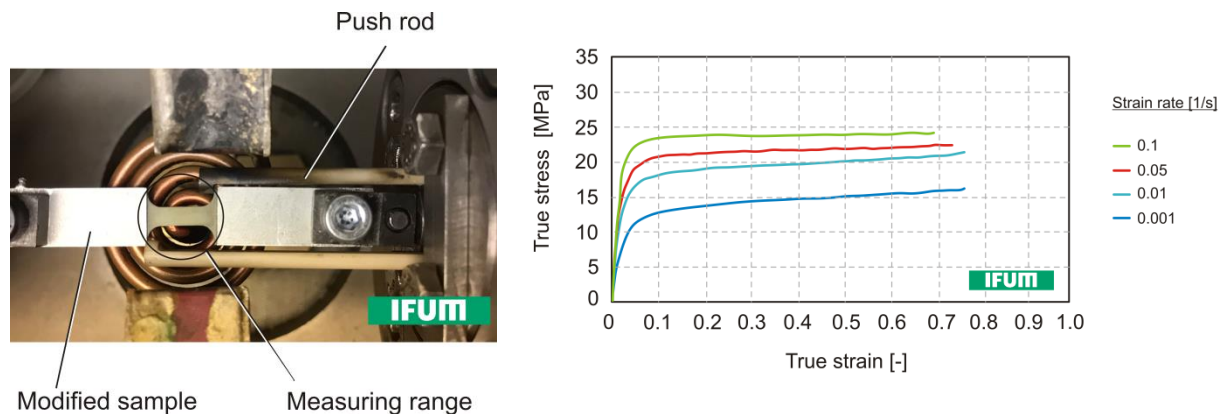
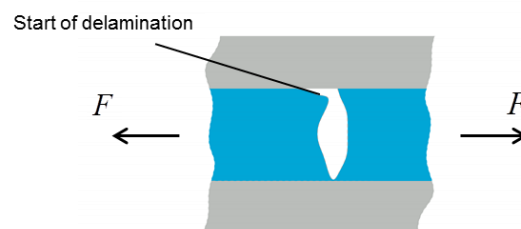

**Figure 3.** Modified tensile test sample (left) and True stress - True strain behaviour of the polymer layer with thickness 0.7 mm for different strain rates.

The experimental set-up and the modified sample concerning the measurement range for the tensile test with the dilatometer are shown in figure 3 on the left side. On the right side the true stress - true strain behaviour for different strain rates is illustrated. With an increasing strain rate the tensile strength of the inner layer increases. In comparison to the sheet metal the polymer layer shows low stress values, but high true strain values.

### 3 Investigation of interface failure

The development of new materials is one approach to face the challenges in the lightweight sector. With the concept of symmetrical sandwich structures different materials with varying behaviour are combined. Based on the layered structure, sandwich structures have different properties as compared to monolithic sheet metals. For this reason in addition to the behaviour of the single layer material the layer interaction has to be taken into account for the design of a deep drawing process. Experimental and numerical investigations for hybrid structures regarding the design of deep drawing processes have been examined in [4]. An important failure mechanism for composites and sandwich structures is delamination. Under combined loading conditions in a deep drawing process a crack occurs and propagates.



**Figure 4.** Delamination failure for sandwich structures, acc. to [5].

In figure 4 a sketch for a delamination process within a sandwich structure is shown. Delamination can start within the core, but the most critical case is the start of delamination at the interface. For composite materials delamination is a well examined failure mechanism and various test procedures can be found in literature. Subject of the article is the transfer of the existing methods for composites to investigations for sandwich structures. In this paper the climbing drum peel test [6] is used to characterize the interface behaviour between two components with different material properties.

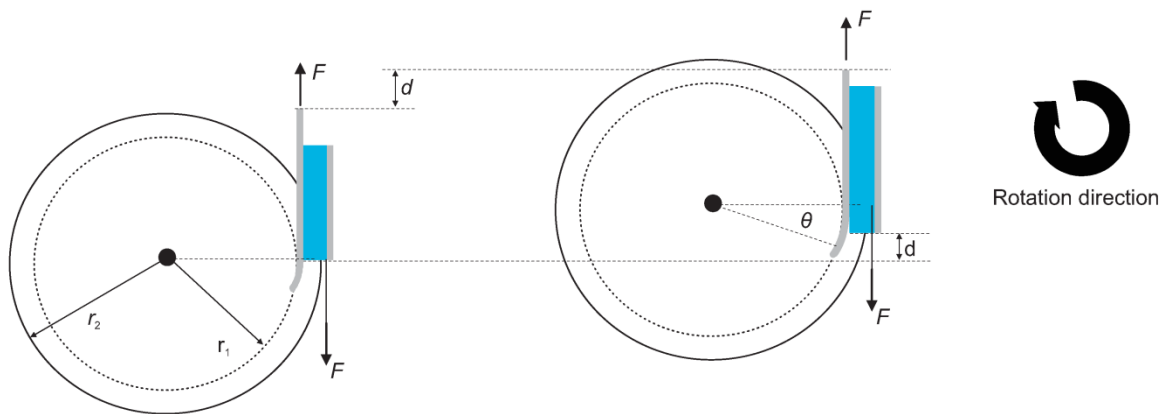

**Figure 5.** Climbing Drum Peel Test, acc. to [6].

In figure 5 the principle function of the climbing drum peel test according to [6] is shown.  $F$  is the applied pulling force,  $r_1$  is the radius of the drum,  $r_2$  is the radius of the flange,  $d$  is the crosshead displacement and  $\theta$  is the occurring rotation angle of the drum. At the beginning a pre-crack is brought into the middle layer, the outer sheet metal layer gets clamped on the drum and the drum is integrated in a tensile machine. Afterwards the set-up undergoes a vertical loading and the drum component rotates clockwise. Based on the force-displacement data an analysis of the delamination behaviour can be carried out.

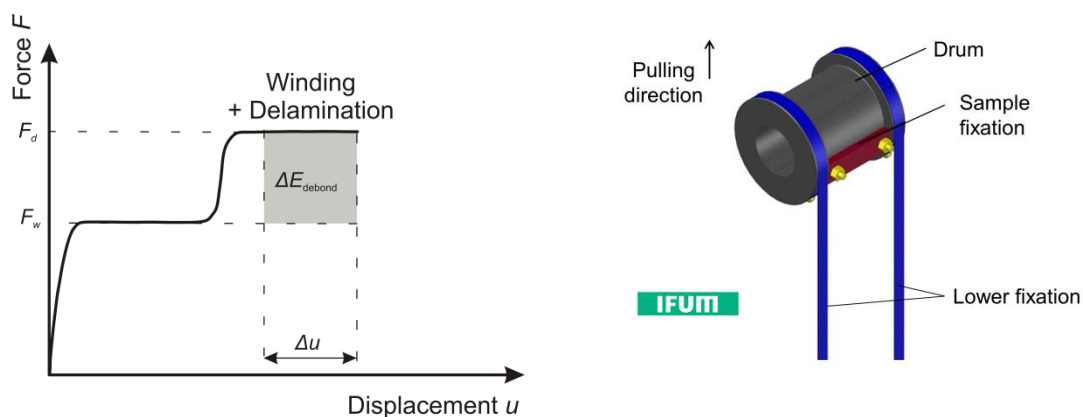

**Figure 6.** Force-displacement curve (left acc. to [7]) and experimental set-up of climbing drum peel test (right).

The force-displacement curve for a climbing drum peel test is shown in figure 6. The first force increase until  $F_w$  is the force needed for the winding of the drum until the point where the pre-crack starts. The second increase up to force value  $F_d$  is the force for winding and delamination of the structure.

With the force-displacement data and the geometrical dimensions of the set-up it is possible to estimate the dissipated energy  $\Delta E_{\text{debond}}$  for the delamination and with this a critical strain energy release rate  $G_C$ .

$$\Delta E_{\text{debond}} = (F_d - F_w) \Delta u \qquad G_C = \frac{\Delta E_{\text{debond}}}{\Delta A} = \frac{F_d - F_w}{w} \frac{r_2 - r_1}{r_2}$$

$\Delta A$  is the area which undergoes a rotation and  $w$  is the width of the sample. With the value  $G_C$  an arising delamination effect is described and this parameter can be used for the numerical modelling of sandwich structures under deep drawing loading conditions.

#### 4 Numerical modelling and FE simulation

For the modelling of the sandwich structure the material properties determined by experimental material characterization procedures presented in section 2 are used. For the numerical modelling of the interface between the sheet metal and the polymer an established approach is the implementation of a traction-separation curve.

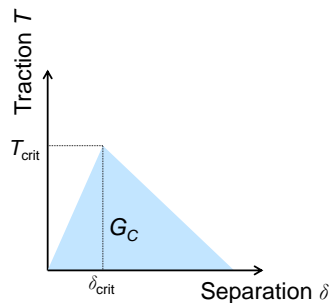

**Figure 7.** Traction-separation curve for numerical modelling of interface failure (acc. to [8]).

The traction-separation curve, e. g. in figure 7, is used to describe the failure mechanism for interfaces between two materials with different characteristics. The interface is modeled with cohesive elements and the behaviour of the elements is described with the traction-separation curve, which is represented by critical values for the traction  $T_{\text{crit}}$  and the separation  $\delta_{\text{crit}}$  the arising of the delamination. The critical fracture energy  $G_C$  considered in section 3 defines the area of the triangle. For a detailed description of cohesive element modelling approach see [8], [9]. To generate a simple test case a tensile test with removed small part of the sheet metal outer layer is modeled to proof the modeling approach for the sandwich structure and the delamination effect. For the numerical modelling of sheet metal and polymer layer the results from the material characterization are implemented and the layers are modeled as solid elements. The interface is modeled with cohesive elements with a thickness of 0.01 mm.

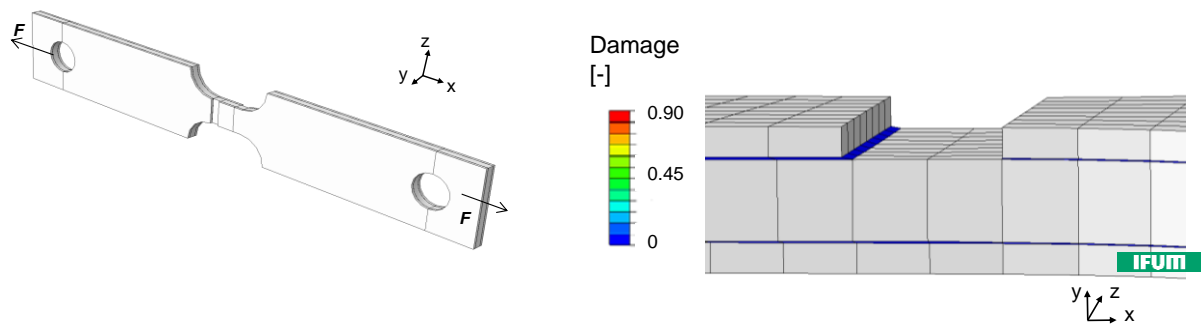

**Figure 8.** FE model for tensile test (left) and damage failure value (right).

On the left side of figure 8 the FE model for the tensile test is shown and on the right the damage value for the FE simulation are presented. The results of the FE simulation show that no significant delamination occurs and a coincidence with the experimental behaviour of the sandwich structure exists. This test case is chosen to proof the modeling approach with solid elements for the layers and cohesive elements for the interface.

## 5 Conclusion

The development of new materials is one approach to face the challenges in the lightweight sector. With the concept of symmetrical sandwich structures different materials with varying behaviour are combined. In this article the material characterization for the different layers, experimental investigations for the interface behaviour and a transfer to one modelling approach for FE simulation of sandwich structures is presented. The FE simulation tryout shows a satisfying prediction for the behaviour of sandwich structure and the interface. For more complex applications additional investigations are needed to describe the material and interface behaviour under different loadings, which can occur in a deep drawing process and influence the behaviour of the sandwich structures in different ways.

## References

- [1] Behrens, B.-A.; Rolfes, R.; Vucetic, M.; Peshekhodov, I.; Reinoso, J.; Vogler, M.; Grbic, N.: Material characterization for FEA of the clinching process of short fiber reinforced thermoplastics with an aluminum sheet; *Advanced Materials Research Vols. 966-967*, 2014, pp. 557-568
- [2] Behrens, B.-A.; Bouguecha, A.; Peshekhodov, I.; Götz, T.; Huinink, T.; Vucetic, M.; Friebe, H.; Möller, T.: Numerical Validation of Analytical Biaxial True Stress - True Strain Curves from the Bulge Test; *8<sup>th</sup> International Conference and Workshop on Numerical Simulation of 3D Sheet Metal Forming Processes (Numisheet)*, 2011, Seoul, South Korea, pp. 107-114
- [3] Sigvant, M.; Mattiasson, K.; Vegter, H.; Thilderkvist P.: A viscous pressure bulge test for the determination of a plastic hardening curve and equibiaxial material data; *Int. J. Mater Form*, 2009 pp. 235-242
- [4] Behrens, B.-A.; Vucetic, M.; Neumann, A.; Osiecki, T.; Grbic, N. (2015): Experimental test and FEA of a sheet metal forming process of composite material and steel foil in sandwich design using LS-DYNA, *18th International ESAFORM Conference on Material Forming*, 15.04.2015 – 17.04.2015, Graz, *Key Engineering Materials Vols. 651-653* (2015), pp 439-445
- [5] Schürmann, H., *Konstruieren mit Faser-Kunststoff-Verbunden*, Springer Verlag, 2007



[6] Nettles, A. T.; Gregory, E. D.; Jackson, J. R.: Using the Climbing Drum Peel (CDP) Test to Obtain a  $G_{IC}$  Value for Core/Face Sheet Bonds, *J. of Composite Materials*, Vol. 41, No. 24/2007, pp. 2863-2876

[7] Daghia, F., Cluzel, C.: The Climbing Drum Peel Test: An alternative to the Double Cantilever Beam for the Determination of fracture toughness of monolithic laminates; *J. Composites Part A: Applied Science and Manufacturing*, Vol. 78, 2015, pp. 70-83

[8] Hallet, S. R; Harper, P. W.: Modelling delamination with cohesive elements, *Numerical Modelling of Failure in Advanced Composite Materials*, Woodhead Publishing Series in Composite Science and Engineering, 2015, pp. 55-72

[9] van den Bosch, M. J.: Interfacial delamination in polymer coated metal sheet, Eindhoven, University of Technology, 2007