

1977

Heavy metal accumulation in a feather moss, *Pleurozium schreberi*, and soils in Northwestern Ontario

Rinne, Robert J. K.

<http://knowledgecommons.lakeheadu.ca/handle/2453/2285>

Downloaded from Lakehead University, Knowledge Commons

Heavy Metal Accumulation in a
Feather Moss, *Pleurozium schreberi*, and Soils
in Northwestern Ontario

A thesis submitted in partial fulfillment of
the requirements for the degree of Master of Science

Robert J. K. Rinne
Lakehead University
Thunder Bay, Ontario
July, 1977.

ProQuest Number: 10611608

All rights reserved

INFORMATION TO ALL USERS

The quality of this reproduction is dependent upon the quality of the copy submitted.

In the unlikely event that the author did not send a complete manuscript and there are missing pages, these will be noted. Also, if material had to be removed, a note will indicate the deletion.



ProQuest 10611608

Published by ProQuest LLC (2017). Copyright of the Dissertation is held by the Author.

All rights reserved.

This work is protected against unauthorized copying under Title 17, United States Code
Microform Edition © ProQuest LLC.

ProQuest LLC.
789 East Eisenhower Parkway
P.O. Box 1346
Ann Arbor, MI 48106 - 1346

THESES
M.Sc.
1977
R58
c.1



Copyright © Robert J.K. Rinne 1977

Canadian Thesis on Microfiche
No. 34741

~~XXXXXXXXXX~~
253319

Declaration

The research presented in this thesis was carried out by the author, and has not been previously submitted for credit toward any degree or diploma.

Where the work of others has been included, it has been appropriately cited.

July, 1977

Abstract

It has been determined that carpet-forming mosses are good indicators of heavy metal deposition, since they are dependent on their supply of nutrients from above rather than from the substrate. Samples of the common carpet-forming pleurocarpous moss *Pleurozium schreberi* (Brid.) Mitt. and the underlying soil were collected during the summer and early fall of 1975 from 105 sites in northwestern Ontario. Analyses were carried out on all samples for the heavy metals Cd, Cu, Fe, Hg, Mn, Ni, Pb and Zn, using atomic absorption spectrophotometry. Results were expressed as ppm (dry weight). Soil pH and loss on ignition were also measured. The results were in general agreement with those reported elsewhere in the literature. As expected, moss analysis was shown to be a more reliable indicator of metal deposition than soil analysis.

The relationship between the moss and soil metal contents was found to be such that in relatively highly polluted areas the soil content ~~of~~^{for} most metals was considerably greater than the moss content, whereas in relatively unpolluted areas the gap between soil and moss content decreased.

The approximate ranges of background concentrations of heavy metals in *P. schreberi* samples collected 50 - 200 km from the city of Thunder Bay were as follows: Cd, 0.50 - 0.64; Cu, 6.6 - 8.8; Fe, 692 - 944; Hg, 0.061 - 0.092; Mn, 290 - 318; Ni, 2.0 - 3.4; Pb, 29.4 - 30.5; and Zn, 65 - 71.

Significant positive correlations in moss metal content were encountered between all possible pairs of metals except those involving Mn. In addition, the concentrations of all metals except Mn in the moss were found to decrease with increasing distance from probable sources of emission, and increase with increasing cover over the collection site.

Significant sources of emissions within the city of Thunder Bay may exist for Cd, Cu, Pb and Zn.

Acknowledgements

I wish to express my sincere appreciation to the following people:

Dr. P. Barclay-Estrup, Biology Department, Lakehead University, who first drew my attention to the research topic, and who provided the guidance, encouragement and constructive criticism that ensured its completion.

Dr. G. Harvais, Biology Department, Lakehead University and Dr. I. Hoodless, Chemistry Department, Lakehead University, who reviewed my progress at intervals and offered guidance and constructive criticism.

Dr. S. Magwood, Biology Department, Lakehead University, who provided constructive criticism.

Mr. A. Perras, Mr. M. Mazurski, Mr. J. Taylor and Mr. D. Murray of the Ontario Ministry of the Environment Northwestern Regional Laboratory, who so generously gave of their time, expertise and facilities to enable me to carry out the laboratory aspects of this work.

Technicians, secretaries and other employees of Lakehead University, who so willingly provided cooperation whenever it was requested.

Table of Contents

	Page
Declaration	i
Abstract	ii
Acknowledgements	iv
Table of Contents	v
List of Tables	ix
List of Figures	xi
 Part 1 - INTRODUCTION	
A) Purpose of Study	1
B) Moss Species Sampled	1
C) Significance of Study	4
D) Studies on Toxicity of Heavy Metals to Bryophytes	4
E) Carpet-forming Mosses as Indicators of Heavy Metal Deposition	5
I) Suitability as Compared to Other Plants	5
II) Capacity for Sorption of Heavy Metals	7
 Part 2 - METHODS AND MATERIALS	
A) Description of Study Area	9
B) Sampling Locations	14
C) Method of Sampling	18
D) Methods of Analysis	19
I) Moss	19
a) Sample Preparation	19
b) Sample Analyses for All Metals Except Hg	20
c) Sample Analysis for Total Hg	26
II) Soil	32

a) Sample Preparation	32
b) Sample Analyses for All Metals Except Hg	32
c) Sample Analysis for Total Hg	33
d) Determination of pH	33
e) Determination of Loss on Ignition	34
E) Analysis of Data	34

Part 3 - RESULTS

A) Checks on Methodology	36
B) Soil Results	41
I) Laboratory Data	41
II) Metal to Metal and Environment Relationships	41
a) Correlations	41
b) Multiple Regression Analyses of the Effect of Distance and Cover	61
III) Soil - Moss Relationships	65
C) Moss Results	75
I) Laboratory Data	75
II) Mean Results According to Sample Groups	75
III) Metal to Metal and Environment Relationships	87
a) Correlations	87
b) Moss - Cover Relationships	87
c) Moss - Distance Relationships	92
d) Regression Analyses of the Effect of Distance and Cover	99
1) Cadmium Regressions	108
2) Copper Regressions	114
3) Iron Regressions	121
4) Mercury Regressions	121
5) Manganese Regressions	121
6) Nickel Regressions	128
7) Lead Regressions	128
8) Zinc Regressions	135

Part 4 - DISCUSSION

A) Adequacy of Methods	143
------------------------------	-----

	Page
B) Soil Metal Relationships	145
I) Metal to Metal Relationships	145
II) Environmental Factors	145
a) Soil pH and LOI	145
b) Cover	147
c) Distance	147
III) Background Levels	147
IV) Comparison of Non-background Levels	150
C) Moss Metal Relationships	150
I) Metal to Metal Relationships	150
II) Environmental Factors	153
a) Soil pH and LOI	153
b) Cover	153
c) Distance	157
III) Background Levels	165
IV) Comparison of Non-background Levels	171
D) Soil - Moss Relationships	171
I) Ratios of Soil Content to Moss Content	171
II) Correlations Between Soil and Moss Content	175
III) Variation in Relationship with Different Degrees of Pollution	176
IV) General Comparison of Soil and Moss	178
E) Distribution Patterns and Possible Sources of Metals	179
I) Comparison of Levels in Sample Groups	179
a) Group I	179
b) Groups II, V	180
c) Group IV	180
d) Group III	181
II) Discussion of Individual Metals	182
a) Cadmium	182
b) Copper	183
c) Iron	183
d) Mercury	184

	Page
e) Manganese	184
f) Nickel	185
g) Lead	185
h) Zinc	186
F) General Discussion and Conclusions	187
Appendix 1 - Site Data	190
Literature Cited	201

List of Tables

Table No.	Description	Page
	Operating conditions of atomic absorption spectrophotometer and mercury meter	25
2	Adequacy of air-drying procedure	38
3	Effect of blending time on metal content of moss	40
4	Reproducibility of moss analysis method (except Hg)	43
5	Reproducibility of soil analysis method (except Hg)	45
6a	Reproducibility of Hg analyses in moss	47
6b	Reproducibility of Hg analyses in soil	49
7	Accuracy of analyses	51
8	Laboratory data - soil	53
9	Pearson correlation coefficients for soil data	60
10	Values required to construct overall linear equations for regression of soil metal content with distance and cover	63
11	Variation in metal content of moss and soil with soil organic content	67
12	Ratios of soil metal content to moss metal content	69
13	Pearson correlation coefficients for metal content of moss correlated with content of soil	72
14	Laboratory data - moss	77
15	Data relating to moss and soil according to sample groups	84
16	Metal content of Sibley Peninsula moss samples	86
17	Pearson correlation coefficients for moss data	89
18	Effect of canopy cover on metal content of moss	91
19	Values required to construct equations for linear regression of metal content of Ignace moss with cover	94

		Page
20	Pearson correlation coefficients for moss metal content correlated with distance for sample Groups II - V	96
21	Effect of distance from city on metal content of moss and soil	98
22	Values required to construct best fit equations for regression of Cd content of moss with distance and cover	110
23	Values required to construct best fit equations for regression of Cu content of moss with distance and cover	116
24	Values required to construct linear equations for regression of Fe content of moss with distance and cover	123
25	Values required to construct linear equations for regression of Hg content of moss with distance and cover	125
26	Values required to construct linear equations for regression of Mn content of moss with distance and cover	127
27	Values required to construct linear equations for regression of Ni content of moss with distance and cover	130
28	Values required to construct best fit equations for regression of Pb content of moss with distance and cover	132
29	Values required to construct best fit equations for regression of Zn content of moss with distance and cover	139
30	Background metal content of soils from present study compared with literature values	149
31	Metal content of soils from polluted areas of the present study and comparison with literature values	152
32	Summary of regression relationships between metal content of moss and cover, with effect of distance accounted for	155
33	Summary of regression relationships between metal content of moss and distance, with effect of cover accounted for	160
34	Background metal content of moss from present study and comparison with literature values	167
35	Metal content of moss from polluted areas of present study and comparison with literature values	173

List of Figures

Figure No.	Description	Page
1	Photo of <i>Pleurozium schreberi</i> - actual size	3
2	<i>P. schreberi</i> carpet on forest floor	3
3	Location of study area	11
4	Main study area	13
5	Main study area, showing locations of sample groups	16
6	Hot block used in Hg analyses	28
7	Fuming of samples for Hg analyses	30
8	Aeration apparatus, mercury meter and recorder	30
9	Histograms showing regional trends in metal content of moss and soil	74
10	Scattergram: Cd content of moss vs. distance from city	101
11	Scattergram: Cu content of moss vs. distance from city	103
12	Scattergram: Pb content of moss vs. distance from city	105
13	Scattergram: Zn content of moss vs. distance from city	107
14	Predicted concentration gradient for Cd content of moss using best fit regression equations for sample group data	113
15	Predicted concentration gradient for Cd content of moss using overall best fit regression equation	118
16	Predicted concentration gradient for Cu content of moss using overall best fit regression equation	120
17	Predicted concentration gradient for Pb content of moss using best fit regression equations for sample group data	134
18	Predicted concentration gradient for Pb content of moss using overall best fit regression equation	137
19	Predicted concentration gradient for Zn content of moss using overall best fit regression equation	141

Part 1

INTRODUCTION

A) Purpose of Study

The main purpose of this study was to determine the concentrations of several heavy metals in a common carpet-forming moss and in the substrate in northwestern Ontario. This involved a determination of levels near the city of Thunder Bay as well as possible background levels. Additional aims were: to determine possible relationships with distance from Thunder Bay, to compare moss and soil levels, and to determine possible relationships with canopy cover.

B) Moss Species Sampled

The pleurocarpous feather moss *Pleurozium schreberi* (Brid.) Mitt. was used exclusively (Figure 1). In a frequency study, P. Barclay-Estrup (personal communication) has shown that this is the most common bryophyte in the study area. It often forms an extensive carpet on the boreal forest floor (Figure 2). An account of the morphology and distribution of the moss is provided by Crum (1973).

Rinne (1975) has determined that there is no significant difference ($p \leq 0.05$) between the metal content of *P. schreberi* and that of another common carpet-forming species, *Hylocomium splendens* (Hedw.) BSG., collected from the same site. *H. splendens* has previously been used in several Scandinavian heavy metal investigations (Rühling and Tyler, 1968, 1969, 1970, 1973).



Figure 1

Pleurozium schreberi, actual size

Figure 2

Carpet of *P. schreberi* on floor of boreal forest

C) Significance of Study

Even small amounts of some heavy metals, notably Pb (Blokker, 1971), Cd (Nordberg, 1974) and Hg (D'Itri, 1972; Olson and Cooper, 1973; The Ontario Public Interest Research Group, 1976) are injurious to man and to other organisms. Tyler (1972, 1974) has hypothesized that heavy metals may reduce the productivity of the ecosystem by inhibiting micro-organisms responsible for decomposition. Simola (1977), on the other hand, speculates that if growth of mosses were promoted by low concentrations of pollutants, paludification of forests could result, which would similarly reduce the productivity of forest ecosystems.

An enrichment of heavy metals occurs to a certain degree in the food chain, but information on the course and extent of this accumulation is incomplete. There is evidence that heavy metal enrichment occurs in decomposing organic matter because of leaching from surface matter (Pakarinen and Tolonen, 1977) and/or because the release of metals upon decomposition of litter is comparatively less than the decrease in litter mass. This accumulation could be suddenly released into the ecosystem after clear-cutting or a forest fire (Tyler, 1972).

D) Studies on Toxicity of Heavy Metals to Bryophytes

Very little research has been done on possible detrimental effects to bryophytes of high concentrations of heavy metals. Simola (1977) studied the effect of Pb and Cd ions on the growth

and fine structure of *Sphagnum nemoreum* Scop. in aseptic cultures. She found that this moss tolerated Pb surprisingly well (11 mg/l solution), suffering only some degeneration of photosynthetic cells. Cd at a similar concentration, however, was lethal.

Coombes and Lepp (1974) found evidence of Cu and Zn damage to *Funaria hygrometrica* Hedw. and to the liverwort *Marchantia polymorpha* L. Cu was found to be the more toxic to both species. Cu levels above 8 mg/l in the medium prevented protonemal growth and inhibited spore germination in *F. hygrometrica*, and reduced the growth of *M. polymorpha* gemmalings. Zn decreased the % spore germination in *F. hygrometrica*. Distinct morphological changes were also observed.

Gullvag et al. (1974) studied Pb accumulation in moss leaves and found that the thick cell wall of *H. splendens* was a potent barrier to Pb penetration into the cytoplasm.

E) Carpet-forming Mosses as Indicators of Heavy Metal Deposition

I) Suitability as Compared to Other Plants

Although vascular plants have been successfully used as determinants of heavy metal deposition near industrial centres (Goodman and Roberts, 1971; Czarnowska, 1974; Hutchinson and Whitby, 1974; McGovern, 1975; Balsillie et al., 1975; McGovern and Balsillie, 1975) and of Pb deposition near roadways (reviewed by Smith, 1976), bryophytes and lichens have been shown to concentrate heavy metals in larger amounts in both natural (Shacklette, 1965) and man-influenced environments (Rühling and

Tyler, 1968; Goodman and Roberts, 1971; Huckabee, 1973; Czarnowska, 1974; Le Blanc et al., 1974).

Most epiphytic bryophytes and lichens are so sensitive to certain environmental factors (e.g. SO₂ pollution) in sites severely affected by human activity that they are almost lacking in densely inhabited or industrialized areas. The resultant distribution patterns have been used to delineate areas subjected to different degrees of pollution (Ferry et al., 1973; Stringer and Stringer, 1974; Le Blanc et al., 1974; Hawksworth and Rose, 1976).

Carpet-forming mosses have no organs for direct uptake of nutrients from the substrate, and there is no direct contact between active, living tissue and the soil in a closed carpet. Thus, they are almost exclusively dependent on their supply of nutrients from above. This makes them good indicators of atmospheric heavy metal deposition, even in relatively unpolluted areas. Atmospheric salts and aerosols in the precipitation, dry deposition of dust, and leaching or washoff from higher vegetation and litter are the main sources of mineral supply to the carpet-forming mosses (Tyler, 1972).

Mosses have been used by Rühling and Tyler (1968, 1969, 1973) and Mäkinen and Pakarinen (1977) to map the deposition of heavy metals in Scandinavia, and by Groet (1976) to relate variations in heavy metal content to atmospheric deposition in the northeastern U.S.A. They have also been used to study heavy metal fallout in industrial sites (Goodman and Roberts,

1971; Tyler, 1971; Burkitt et al., 1972; Czarnowska, 1974; Little and Martin, 1974; Le Blanc et al., 1974) and Pb deposition near roadways (Rühling and Tyler, 1968; Warren, 1976). In addition, Yeaple (1972) and Huckabee (1973) have shown that mosses are sensitive indicators of air-borne Hg pollution; and Wallin (1976) used a carpet-forming moss to survey deposition of Hg from chlor-alkali plant emissions.

II) Capacity for Sorption of Heavy Metals

Rühling and Tyler (1970) have established the great capacity of *H. splendens* for sorbing of heavy metals from dilute solutions. They found the degree of sorption between heavy metal cations and negatively-charged organic groups to follow the order: Cu, Pb>Ni>Co>Cd>Zn>Mn. Even traces of Cu and Pb were shown to be quickly and quantitatively sorbed from dilute solutions containing relatively large amounts of other ions (Na, K, Ca, Mg).

Le Blanc et al. (1974) determined a somewhat different order of the relative degree of sorption of heavy metals by *H. splendens*, this being: Pb > Cu > Zn > Cd. They speculate that the order may not be constant in a particular species but rather may vary from one geographical area to another.

Svensson and Liden (1965) have demonstrated the capacity of *P. schreberi* for sorbing radioactive fallout from nuclear bomb tests. The fission products $^{95}\text{Zr} + ^{95}\text{Nb}$ and $^{140}\text{Ba} + ^{140}\text{La}$ were almost quantitatively retained.

The passive sorption of heavy metal ions is mainly a process of simple ion exchange. When samples of *H. splendens*

were treated with dilute NiCl_2 solutions, they released an equivalent amount of other cations in exchange for Ni^{2+} . However, only 2/3 of the Cu content of Cu-saturated samples could be removed by repeated leaching with strong MgCl_2 solutions, the remaining Cu being retained chelated in an almost inexchangeable form (Rühling and Tyler, 1970).

The inability of carpet-forming mosses to sorb minerals directly from the substrate, the great cation exchange capacity of their tissues, and the stability of the chelates formed between heavy metal ions and organic groups, make these organisms suitable indicators for surveying heavy metal deposition.

Part 2

METHODS AND MATERIALS

A) Description of Study Area

The study area is located in northwestern Ontario, Canada, centred about the city of Thunder Bay (population 117,000 (1976)), on the north shore of Lake Superior (Figure 3). The main study area (Figure 4) lies between 88° and 92° west longitude and between 48° and 50° north latitude.

In general, the area is relatively remote from large urban or industrial centres. Thunder Bay itself contains no real metallurgical industries, and the nearest city of comparable size is more than 250 km distant to the south-west. The northern-most region of the study area, located 200 km from Thunder Bay, lies within a region that must be considered to be essentially free of local pollution sources.

Two forest regions (Rowe, 1972) are present in the study area. The greater part of the area (i.e. north of Thunder Bay) is situated in the southern part of the Boreal forest region (corresponding to the Southern Boreal forest zone recognized by Ahti (1964)), the characteristic tree species being *Picea mariana* (Mill.) BSP. and *P. glauca* (Moench) Voss; other conifers are *Larix laricina* (Du Roi) K. Koch, *Abies balsamea* (L.) Mill. and *Pinus banksiana* Lamb. There is also a general admixture of broad-leaved trees such as *Betula papyrifera* Marsh., *Populus tremuloides* Michx. and *P. balsamifera* L.

To the west and south of Thunder Bay lies the western-most segment of the Great Lakes - St. Lawrence forest region (placed within the Hemi-boreal forest zone by Ahti (1964)),

Figure 3

Location of study areas with main study area outlined

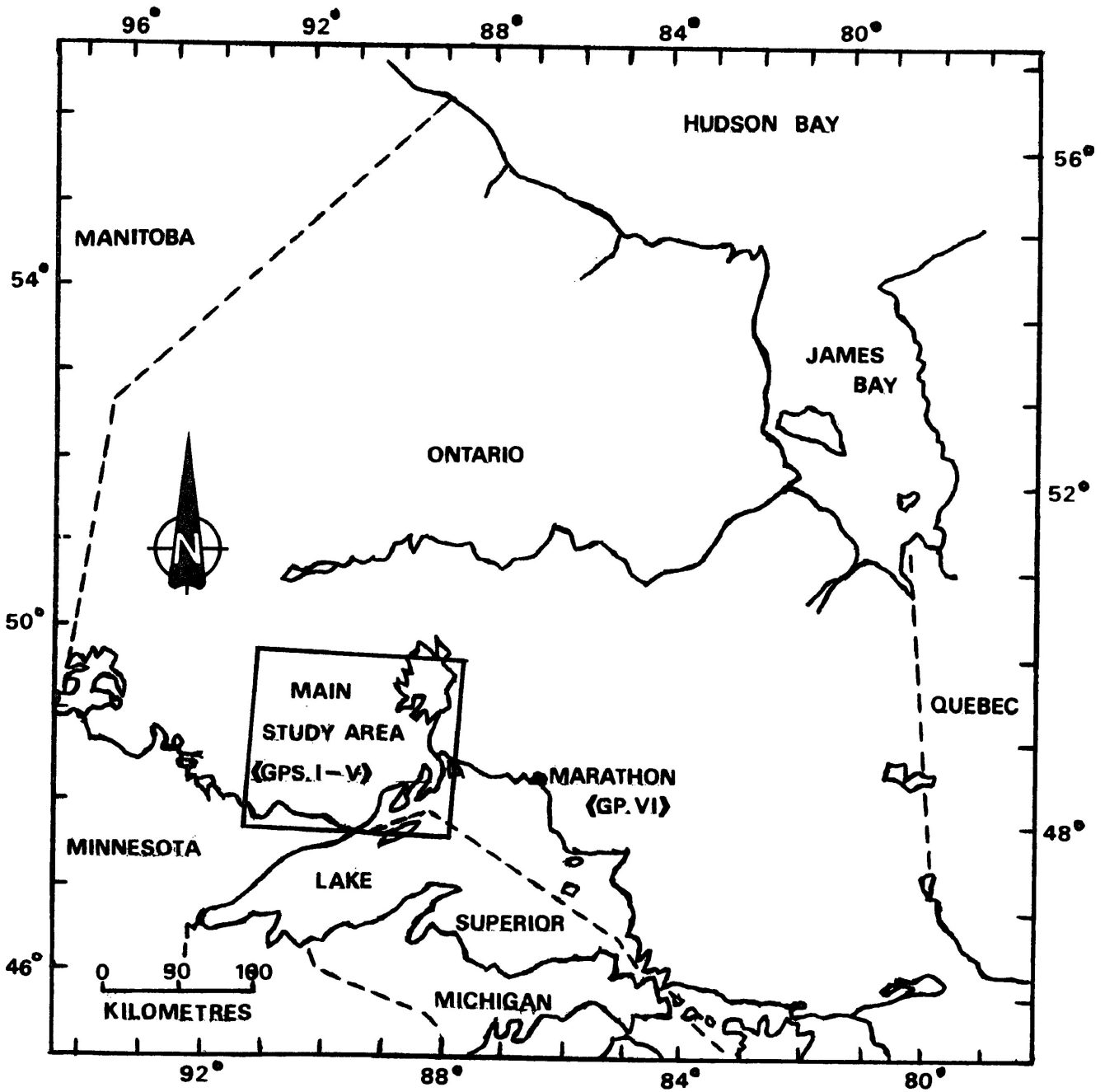
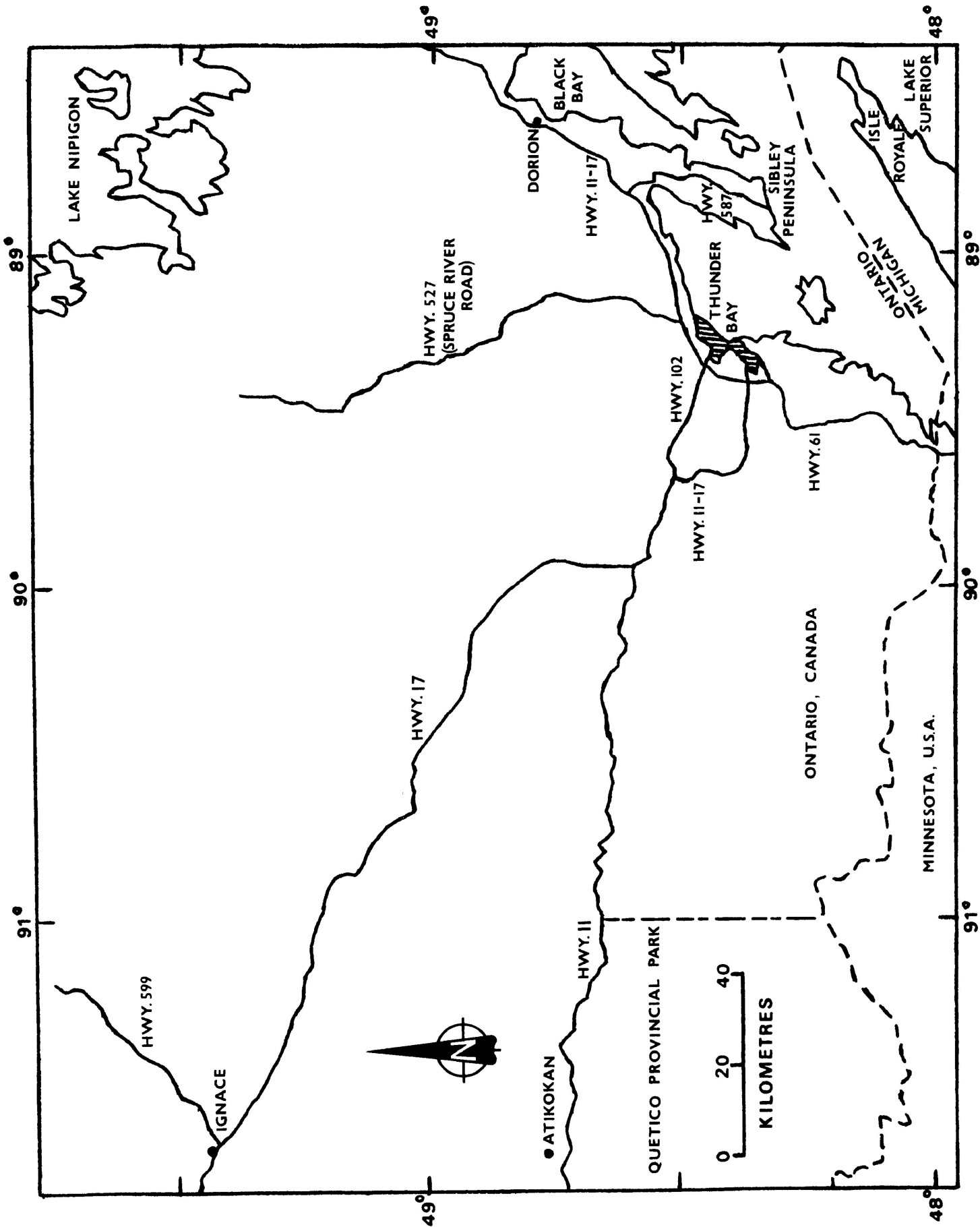

Figure 4

Main study area



large areas of which are dominated by *Pinus strobus* L. and *Pinus resinosa* Ait. Disturbances such as logging and fire have resulted in frequent pure or mixed stands of *P. banksiana*, *P. tremuloides*, *B. papyrifera*, *A. balsamea*, *P. glauca*, and *P. mariana* (i.e. virtually all the species characteristic of the Boreal forest region to the north), associated with varying amounts of *P. strobus* and *P. resinosa*. There is, in addition, a scattering of various other hardwoods.

The elevation of the study area varies between approximately 200 m near the lake to 450 m inland. Mean annual precipitation is approximately 800 mm.

The prevailing wind at Thunder Bay is from the west. The regional wind distribution (compiled from unpublished Environment Canada statistics for the period 1958 - 72) is shown in Figure 5.

B) Sampling Locations

A total of 105 sites were sampled during the period June to October, 1975. (Rühling and Tyler (personal communication) have observed no seasonal variations in the metal content of carpet-forming mosses.) These 105 sites have been divided into 6 groups, the locations of which are shown in Figures 3 and 5. A more exact location of each site, as well as associated dominant species, is given in Appendix 1.

For the purposes of examining distance relationships around Thunder Bay, sites in Groups II - V were divided as follows:

Figure 5
Main study area

- Showing locations of sample groups

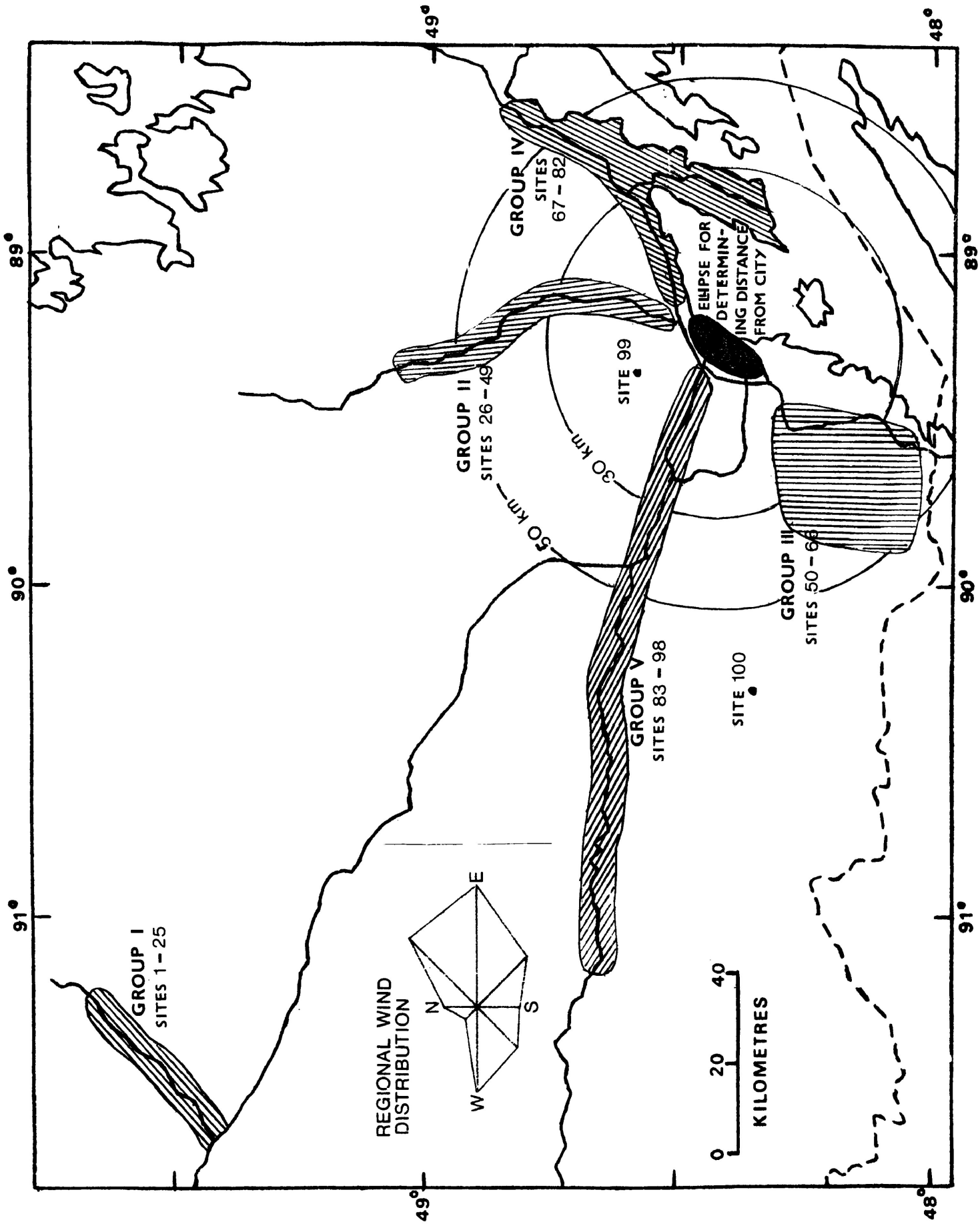

"proximate" sites = sites < 30 km from city

"distant" sites = sites > 50 km from city (excluding
Groups I and VI).

Group I sites (No. 1-25) were situated at approximately 1.6 km-intervals along a transect parallelling Hwy. 599, near Ignace, Ont., 200 km north-west of Thunder Bay. Group II sites (No. 26-49) parallelled Hwy. 527, at approximately 3.2 km-intervals, ranging in distance from 5 to 65 km north of the urban limit of Thunder Bay (see Figure 5). Group III sites (No. 50-66) were dispersed in the region south, south-west of Thunder Bay between the city and the International Border between Canada and the United States (approximately 50 km away). Sites in Group IV (No. 67-82) were located east from Thunder Bay as far as Dorion (60 km distant) and along the Sibley Peninsula. Sites in Group V (No. 83-98) lay along a transect which followed Highways 102, 11/17 and 11 as they extend in a westerly direction from Thunder Bay. These sites were situated from 4 to 137 km west of the urban limits of the city. Site 99 was located 20 km north of Thunder Bay while site 100 was situated 73 km west, south-west of the city. Group VI sites (No. 101-105) were located at Marathon, Ont., 200 km east of Thunder Bay.

In order to minimize effects of emission sources immediately adjacent to the sampling sites, primarily as regards Pb in automobile exhaust, all sites (with the exception of those in Group VI) were located at least 50 m, but usually 100 m or more, from roadways. Although a minimum distance of 300 m has been selected by some investigators (Rühling and

Tyler 1969, 1973; Goodman and Roberts, 1971; Pakarinen and Tolonen, 1976), it was not considered practical to maintain this distance due to dense vegetation and difficulty of the terrain.

In addition, analyses have indicated that the decrease in Pb content of vegetation is logarithmic and so dramatic that a 50% reduction is effected within the first 10 - 20 m (Ward et al., 1975), and that the background level is attained after 40 m (Pakarinen and Tolonen, 1976).

In view of these findings, and the fact that traffic flows on northwestern Ontario roadways are relatively light, 50 m was considered an adequate distance for the purposes of this investigation.

Where possible, sites were selected so as to have a minimum of overlying vegetation canopy or cover in order to reduce contamination via run-off (stem flow) and to maintain a relatively uniform degree of exposure to particles in the atmosphere.

C) Method of Sampling

After a suitable site had been chosen, approximately 25 g of moss were gathered via a "grab" method (so that a sample consisted of green moss tissue plus any dead or dying brown tissue which "came away" when the living material was pulled from the substrate). This method of sampling *P. schreberi* is the same as that employed by Damman (1971). The sample was placed in a clear plastic bag and sealed with a twist-tie.

A soil sample, composed of an approximately 10 cm x 10 cm x 5 cm volume of substrate from directly below the moss sampling location, was also collected and placed in a plastic bag. In some instances it was not possible to collect soil when the substrate^{te} consisted of rock or wood.

Lists of those trees and upright shrubs either rooted in or partially overhanging a 2 m x 2 m quadrat, centred about the sampling site, were compiled. These are contained in Appendix 1 - Site Data. The nomenclature is that of Lakela (1965). An estimate was also made of the % canopy closure or cover of each quadrat, and a value of 1 to 5 assigned based on an approximate cover of 0 - 20% (1) up to 80 - 100% (5).

The labelled moss and soil samples were placed in a deep freeze within 24 h of collection and maintained at approximately -10°C until the analyses were begun.

D) Methods of Analyses

I) Moss

a) Sample Preparation

Moss samples were removed from the deep freeze in batches of 25 and, after having thawed, were carefully sorted by hand to remove foreign material. A washing procedure was not undertaken. Previous analyses (Rinne, 1975) had shown that washing did not significantly reduce the apparent metal content of *P. schreberi* collected in relatively uncontaminated sites. Also, Tyler (personal communication) has found that even distilled water-washing can increase the Cu content of

P. schreberi, because the moss has a very great capacity for sorption of this metal.

The samples were spread out on aluminum trays and air-dried for a minimum of 48 h. In order to ensure that this method provided an essentially complete removal of moisture, 5 weighed, air-dried samples were oven-dried at 80°C for 4 h and re-weighed.

The air-dried samples were ground in a Waring blender at high speed for approximately 1 min. The resultant powdered moss was poured into acid-washed glass jars and sealed with plastic caps.

In order to test for possible contamination from the stainless steel blades of the blender, portions of 9 moss samples were ground at high speed for an additional 4 min.

Dry, pre-ground orchard leaf samples (Standard Reference Material No. 1571, of the National Bureau of Standards, U.S. Dept. of Commerce) were used as a control for the sample ashing and instrumental analyses. They were not placed on the aluminum trays, nor were they ground in the blender.

The actual analyses were performed by the author during the period January 1976 to January 1977 at the Ontario Ministry of the Environment Laboratory in Thunder Bay.

b) Sample Analyses for All Metals Except Hg

Through a process which combined previous experience (Rinne, 1975) with a great deal of trial and error, the following digestion procedure was adopted. It provides for an essentially

complete digestion of organic matter without the use of perchloric or hydrofluoric acids, while at the same time minimizing losses of volatile elements such as Cd and Pb. The method was originally based on one suggested by Brooks (1972) but has involved considerable modification. All glassware was acid-washed in 10% HCl, rinsed 4 times in running tap water and 6 times in deionized, distilled water.

One gram portions of the dry, powdered moss were placed into 25 x 200 mm test tubes and ashed for 12 h at 450°C. This temperature was selected because it was determined (personal communication, D. Murray) that significant losses of Cd and Pb could occur at higher temperatures. Upon removal from the muffle furnace and subsequent cooling, 4 ml of HNO₃ and 1 ml of HCl were added to each tube. A blank solution containing only these acids was prepared at this point. The samples were then heated in a water bath on a hot block for ½ h, or until yellow fuming had ceased (indicating that HNO₃ was no longer present). The samples were cooled again and approximately 15 ml of deionized, distilled water were added. All samples were then filtered through 9 cm glass-fibre filter papers into graduated 25 x 200 mm test tubes and made up to 50 ml volume. Squares of "Parafilm" brand plastic film were placed over the tubes, which were then inverted 6 times to ensure complete mixing. The small amount of suspended matter present in most tubes was allowed to settle.

A Varian-techtron model AA-5 atomic absorption spectrophotometer was used for analyses of the heavy metals

Cd, Cu, Fe, Mn, Ni, Pb and Zn. Analyses were carried out directly on the filtrate for all but Mn and Fe, which generally required a 5-X dilution. $\text{Co}^{\text{-balt}}$ analysis was attempted, but levels were found to be below the instrument detection limit for most samples. A hydrogen ion discharge lamp, which corrects for background signals not attributable to the metal being measured, was found to be necessary only for Ni and Cd, due to their naturally low levels. It was determined after the analyses were complete that the hydrogen discharge lamp is "difficult to use" for Ni because its output spectrum contains a superimposed Ni spectrum (Kahn and Manning, 1972). The actual effect that this would have on specific determinations is, however, not known, but it is felt that the effect would be relatively constant and should not affect comparisons of the data within the context of the study. In any event, it was discovered that when background correction for Ni was not used for the orchard leaves, a large positive error resulted. It was therefore assumed that a similar error would result if background correction were not used for the moss and soil samples.

Although the AA-5 instrument was equipped with a digital readout which could be set to present an average reading over several different time intervals, it was not used. Instead, peaks were recorded on graph paper and metal concentrations subsequently calculated from standard curves. This latter method was found to provide a greater degree of accuracy because fluctuations in the baseline were visible and easily

corrected for.

The instrument settings employed for the various metals are listed in Table 1. The detection limits are also given here, along with an explanation of how they were arrived at.

Standard solutions of the metals were prepared from either stock solutions or the pure metal (commercially available) as obtained from the Ministry of the Environment laboratory. They were adjusted to the pH range of the samples in order to minimize matrix error.

To obtain data on the reproducibility (precision) of the method, the same moss sample was digested and analyzed in duplicate during each of 6 different runs. The accuracy of the analyses for each of the metals was judged from the results obtained from repeated determinations of the orchard leaf samples.

Parts per million, dry weight (ppm = mg/kg) of a metal was calculated according to the following formula:

$$\text{ppm (dry wt.)} = \frac{\text{mg of metal in sample}}{\text{wt. of sample (g)}} \times 1000$$

where mg of metal in sample =

$$\frac{(\text{sample peak ht.} - \text{blank peak ht.})(\text{units}) \times \text{ppm/unit} \times \text{sample vol. (ml)}}{1000}$$

For a 50 ml sample volume, this reduces to:

$$\text{ppm (dry wt.)} = \frac{\text{net peak ht. (units)} \times \text{ppm/unit} \times 50}{\text{wt. of sample (g)}}$$

Table 1a

Operating conditions of Varian-techtron model AA-5
atomic absorption spectrophotometer

The detection limits are based on the use of a 1 g
sample of both moss and soil.

Table 1b

Operating conditions of Pharmacia Fine Chemicals mercury
meter

The detection limits are based on the use of a 0.3-g
moss sample and a 0.2-g soil sample.

*Detection limits were calculated by determining the
minimum concentration in a standard that would produce
a readable peak height, less any blank, on 9 out of 10
occasions, using the same instrument and chart recorder
settings that were normally employed during actual anal-
yses (Slavin et al., 1972).

Element	Wavelength ° (Å)	Slit Width (u)	Lamp Current (mA)	Bkgd. Correc- tion	Detection Limit* (mg/l)
Cd	2 287	200	5	yes	0.10
Cu	3 248	100	3	no	1.8
Fe	2 483	50	5	no	40
Mn	2 795	50	5	no	10
Ni	2 320	50	8	yes	0.5
Pb	2 170	300	5	no	2
Zn	2 139	200	5	no	3

Element	Wavelength ° (Å)	UV Monitor Range Setting	Recorder Setting (mv)	Air Flow Rate (l/min)	Detection Limits* Moss	Limits* (ppm) Soil
Hg	2 537	0.08	10	3.4	0.01	0.02

c) Sample Analysis for Total Hg

The following procedure was also arrived at through a lengthy process of trial and error. It is based on the method used routinely by the Ontario Ministry of the Environment (1973) for determination of total mercury in biological material, but again contains considerable modification. All test tubes were soaked in a "Decon-70" soap solution for at least 24 h, followed by 6 rinsings in hot tap water. A number of tests (not recorded) showed that acid-washing and distilled water-rinsing were unnecessary.

Three-tenths of one gram of each dried sample were weighed into a 25 x 200 mm test tube and 9 ml of HNO_3 followed by 8 ml of H_2SO_4 were added. Digestion was carried out on specially constructed aluminum blocks, heated to a temperature of approximately 200°C on a hot block (Figure 6). Digestion was allowed to proceed until white fumes of H_2SO_4 were emitted (Figure 7) and the samples were a clear, pale-yellow colour with a white residue of silicate material. After cooling, about 25 ml of distilled water were added, followed by 1 ml of saturated KMnO_4 solution to ensure complete oxidation. The test tubes were swirled to distribute the permanganate evenly, and allowed to sit for 15 min. Then 1 ml of 20% (wt./vol.) hydroxylamine sulphate solution was added to reduce the excess permanganate. The sample was made up to 50 ml volume with tap water and poured into a Dreschel bottle. Another 50 ml of water were added to the tube and this was also

Figure 6

Diagram showing construction of aluminum hot-blocks used in
digestion of samples for Hg analysis

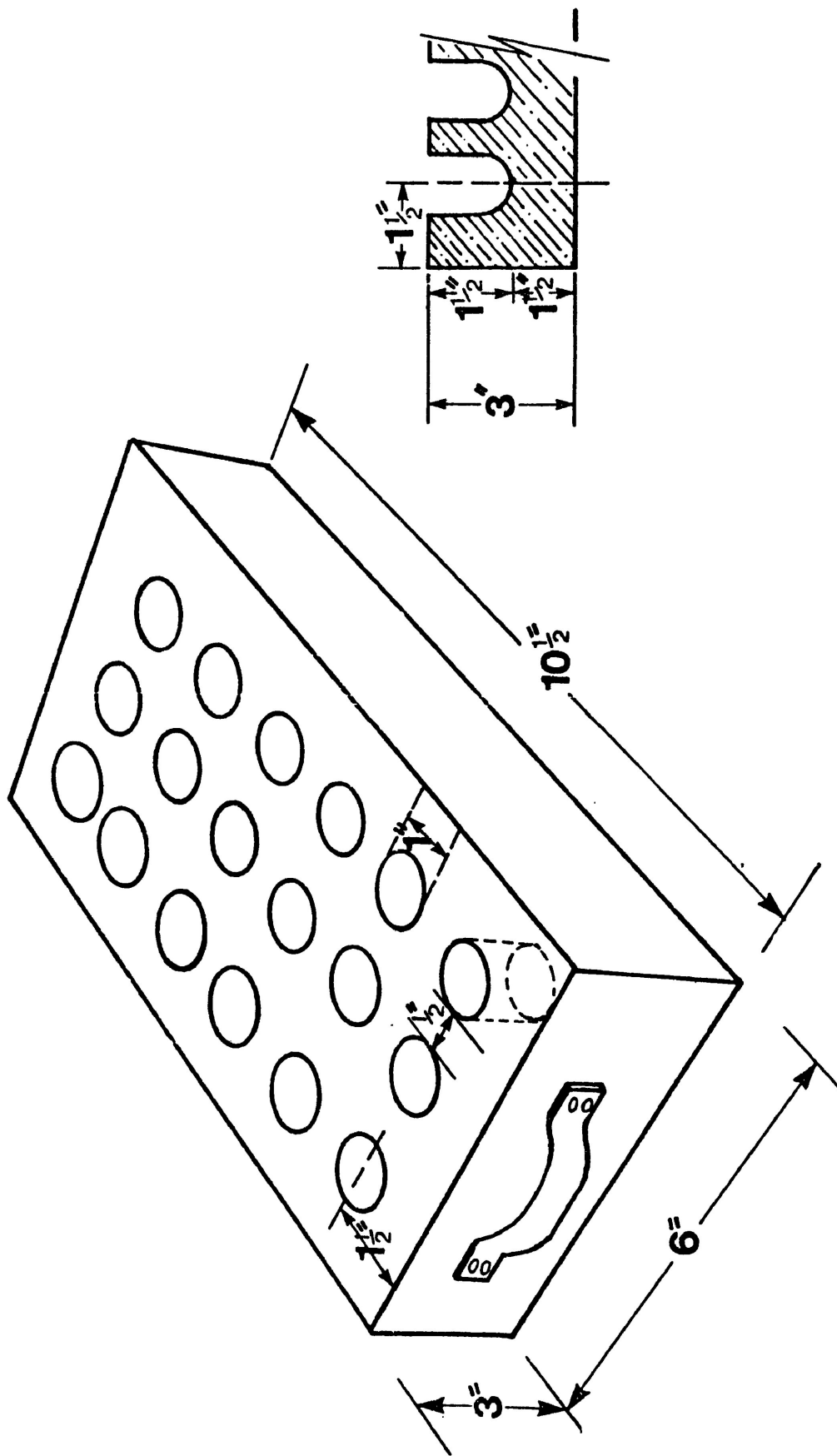

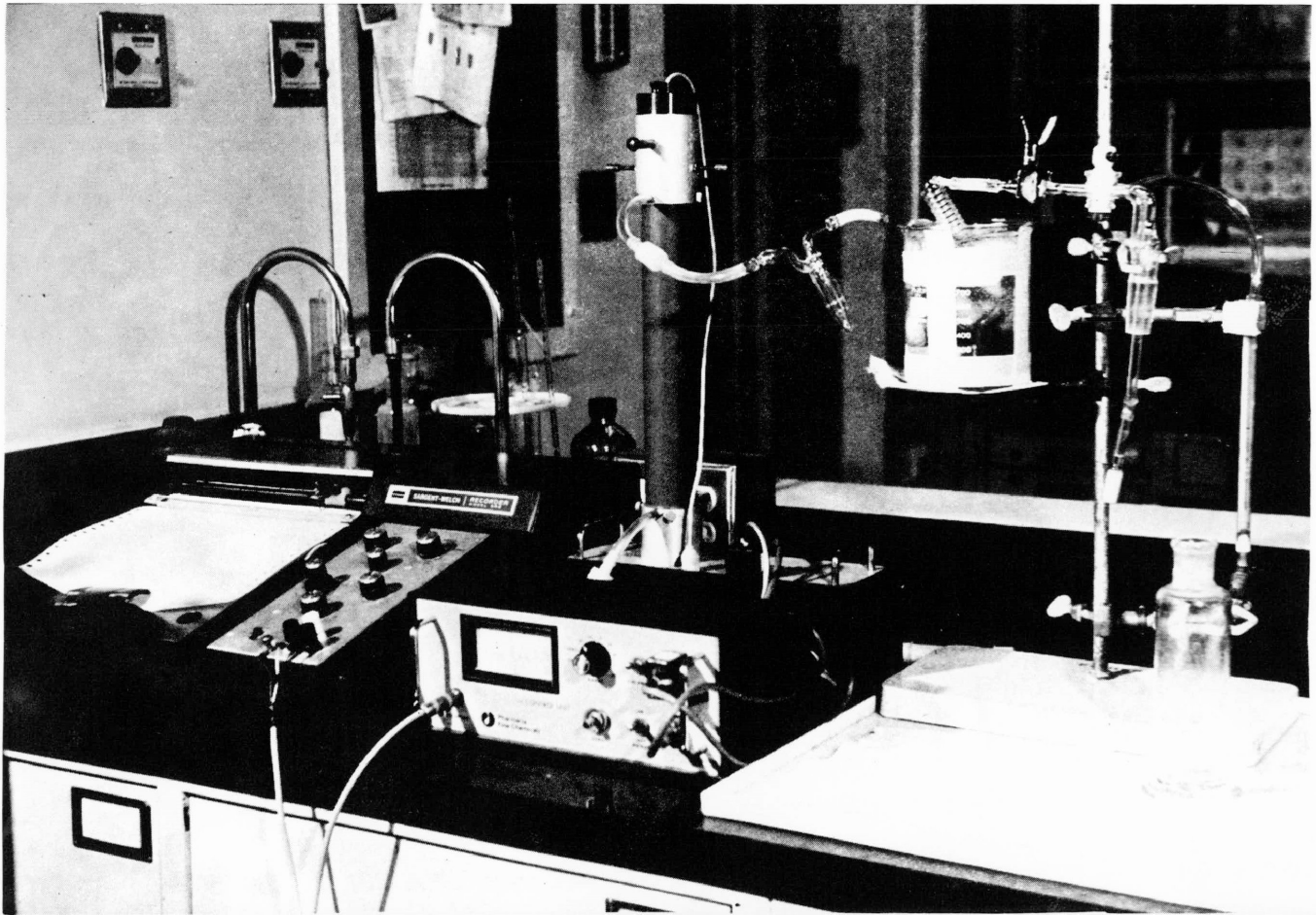
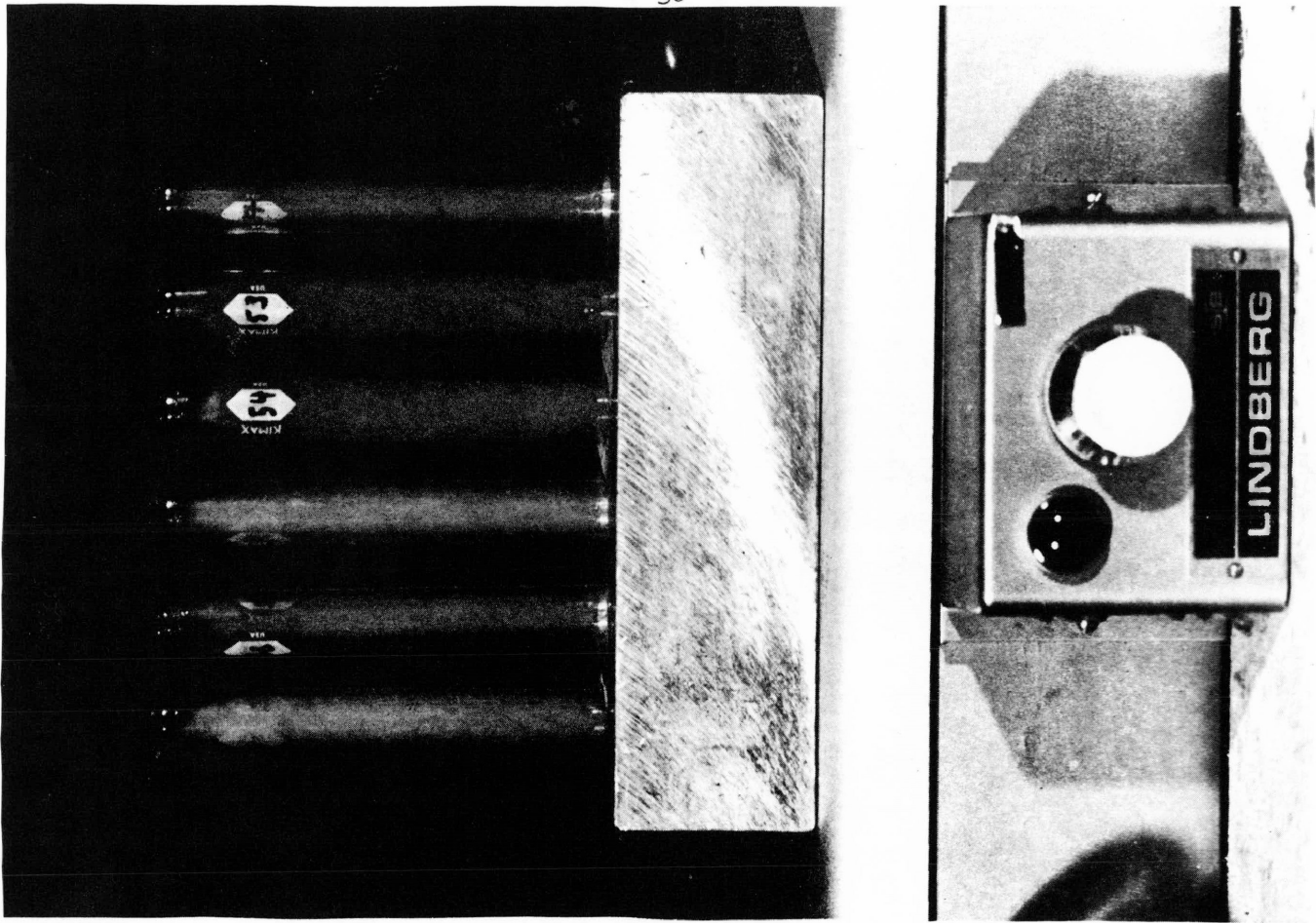

Figure 7

Mercury samples fuming on hot-plate, indicating completion
of digestion

Figure 8

Aeration apparatus, mercury meter and recorder

poured into the bottle (final vol. = 100 ml). Three millilitres of SnCl_2 solution (20% wt./vol. in conc. HCl) were added via a thistle tube, and the sample was immediately attached to the aeration apparatus (which bubbled air through the sample and then drew it through the column). Total Hg was determined by absorption at 253.7 nm using a Pharmacia Fine Chemicals mercury meter, and presented as a peak height on a recorder. The aeration apparatus, mercury meter and recorder are shown in Figure 8.

Organic mercury stands of 0.05, 0.10, 0.15 and 0.20 ug/ml Hg were prepared for each run from a methyl mercuric chloride stock solution (500 ppm) made by dissolving 0.6258 g CH_3HgCl in 1000 ml of methanol. Inorganic mercury standards were not routinely prepared because experimentation had shown them to be unnecessary.

To obtain data on the reproducibility (precision) of the method, 20 different samples were analyzed in duplicate over 4 different runs. Also, to obtain data on the accuracy of the analyses, orchard leaf samples (previously described) were digested and analyzed in duplicate during each run.

An average run consisted of 4 organic mercury standards in duplicate, 4 blanks, the orchard leaf sample in duplicate and approximately 30 moss samples, including several in duplicate.

Parts per million of Hg in a sample was then calculated in the same manner as previously described for the other metals.

II) Soil

a) Sample Preparation

Soil samples were removed from the freezer in batches of 25, allowed to thaw at room temperature, and spread out on aluminum trays to air-dry for a minimum of 48 h. The samples were then sieved through a polyethylene dish in which 2 mm-diameter holes had been drilled, and poured into acid-washed glass jars with plastic caps.

Metal analyses were again performed by the author at the Regional Laboratory of the Ontario Ministry of the Environment. Determinations of pH and Loss on Ignition (LOI) were performed at Lakehead University, using methods suggested by Atkinson et al. (1958).

b) Sample Analyses for All Metals Except Hg

The digestion procedure that was ultimately adopted is exactly the same as that used for the moss samples. This procedure resulted in an essentially total digestion (indicated by a minimum of residue after filtration) of the highly organic soils. Those relatively fewer samples containing large amounts of inorganic matter undoubtedly were not subjected to total digestion and thus their actual total metal contents may be greater than those stated.

Burkitt et al. (1972) used only 8 ml concentrated HNO_3 to extract Pb, Zn and Cd from 1 g soil samples. They state that experimentation with HF-dissolution showed that this simple method gave results that were uniformly about 90%

of absolute values.

Analyses were again performed with a Varian-techtron model AA-5 atomic absorption spectrophotometer in an identical fashion to that previously described for the moss.

c) Sample Analysis for Total Hg

The entire procedure is identical to that used for the moss samples.

The results of an interlaboratory quality control study conducted by Environment Canada (1977) indicate that this method provides results which compare very favourably with those obtained in other laboratories. In this study, the above method was used to determine total Hg in 5 different Great Lakes sediment samples. In all 5 cases, results were almost identical to the means for the 25 laboratories which participated.

d) Determination of pH

Ten grams of dry soil were weighed into a 50 ml beaker, and 25 ml of distilled water were added. The mixture was stirred with a glass rod immediately, and again after 5, 10, 15 and 25 minutes had elapsed. The pH was measured at the end of 30 min with a Bechman pH meter, incorporating a glass measuring electrode and a calomel reference electrode. The meter was first allowed to warm up for approximately 30 min, and was standardized with a pH 4.01 buffer solution.

e) Determination of Loss on Ignition

Approximately 2 g of air-dried material were placed into pre-weighed porcelain crucibles, and oven-dried overnight at 105°C. The oven-dried soils and crucibles were weighed to the nearest 0.001 g, and placed into a muffle furnace. The furnace was allowed to attain a temperature of 450°C, and was maintained at this temperature for 2 h. The crucibles were then removed from the furnace, cooled to room temperature in a desiccator, and reweighed. Per cent loss on ignition was calculated according to the following formula:

$$\% \text{ LOI} = \frac{\text{oven-dried wt.} - \text{burnt wt.}}{\text{oven-dried wt.} - \text{wt. of crucible}} \times 100$$

E) Analysis of Data

Once the concentrations of the various metals in the samples had been calculated, the data was subjected to rigorous statistical analysis using the IBM 360/50 model computer at Lakehead University in Thunder Bay. The Statistical Package for the Social Sciences (Nie et al., 1975) was extensively employed.

The statistical analysis procedure culminated in multiple regression analyses of the variation of metal content with distance from the city of Thunder Bay, while controlling for the effect of canopy cover. The relationship that best expressed this variation was selected from among linear, semi-logarithmic, logarithmic, and reciprocal relationships.

Metal deposition rates (i.e. mg/m²/y) were not calculated

because no attempt was made to determine the biomass of *P. schreberi*. The best that could have been obtained, at any rate, would be a crude estimate since the growth rates of samples collected for analysis varied.

Part 3

RESULTS

The results of the chemical and mathematical analyses are presented below. They are arranged under the following major headings: A) Checks on Methodology

B) Soil Results

I) Laboratory Data

II) Metal to Metal and Environment Relationships

III) Soil - Moss Relationships

C) Moss Results

I) Laboratory Data

II) Mean Results According to Sample Groups

III) Metal to Metal and Environment Relationships

A) Checks on Methodology

Table 2 contains the air-dried and oven-dried weights of 5 moss samples as a check on the adequacy of the air-drying procedure. The additional loss of weight accomplished by oven-drying was 2.40%. This indicates that the air-drying procedure is acceptable. It was therefore adopted for use in this study.

Table 3 compares the results obtained for 9 moss samples ground for 5 min with those for the same samples ground for the usual 1 min. This serves as a test for possible contamination from the blender. The results of a "paired comparison" test determined that the 5 min moss concentrations for Fe and Ni are significantly higher ($p \leq 0.05$) than the 1 min concentrations.

Table 2

Adequacy of air-drying procedure

+ At laboratory temperature and humidity, for 48 h.

‡ At 80°C for an additional 4 h.

Sample No.	Air-dry Wt. [†] (g)	Oven-dry Wt. [‡] (g)	% Decrease
1	2.021	1.973	2.38
2	2.444	2.390	2.22
3	2.752	2.665	3.18
4	3.456	3.394	1.79
5	2.809	2.740	2.45
Mean	2.696	2.632	2.40 ± 0.50

Table 3

Effect of blending time on metal content (ppm,
dry wt.) of *P. schreberi* samples

5 - 1 = 5 min result - 1 min result

Mean \pm S.D. = mean \pm standard deviation of (5-1) results

[] indicates results not used in computations

5 min results significantly higher than 1 min results:

* = $p \leq 0.05$
** = $p \leq 0.01$
*** = $p \leq 0.001$

Sample No.	Blending Time (min)	Observed Metal Concentrations (ppm)							
		Cd	Cu	Fe	Hg	Mn	Ni	Pb	Zn
29	1	0.60	6.3	990	0.09	80	2.6	35.9	54
	5	0.55	7.1	1 150	0.08	75	3.9	36.3	59
	5-1	-0.05	0.8	160	-.01	-5	1.3	0.4	5
31	1	0.50	5.8	630	0.07	291	3.7	37.4	67
	5	0.50	5.4	630	0.07	279	3.5	38.4	52
	5-1	0	-0.4	0	0	-12	-0.2	1.0	-15
32	1	0.65	6.7	600	0.10	140	2.7	33.4	64
	5	0.80	7.0	650	0.10	148	2.6	33.4	48
	5-1	0.15	0.3	50	0	8	-0.1	0	-16
36	1	0.70	7.1	780	0.06	305	2.2	28.4	77
	5	0.70	7.7	860	0.06	301	4.0	28.0	73
	5-1	0	0.6	180	0	-4	1.8	-0.4	-4
38	1	0.45	7.7	730	0.13	269	2.7	22.7	49
	5	0.50	7.6	770	0.12	277	4.6	27.4	62
	5-1	0.05	-0.1	40	-.01	8	1.9	4.7	13
40	1	0.50	27.8	8 340	0.05	172	16.2	30.2	81
	5	0.55	28.2	8 530	0.05	179	21.8	28.5	85
	5-1	0.05	0.4	190	0	7	5.6	-1.7	4
41	1	0.50	11.7	3 000	0.08	150	7.8	35.9	[51]
	5	0.55	11.4	2 960	0.08	150	11.9	35.2	[142]
	5-1	0	-0.3	-40	0	0	4.1	-0.7	
44	1	0.55	9.0	930	0.06	99	3.9	39.6	44
	5	0.55	6.8	890	0.06	93	4.4	42.4	52
	5-1	0	-2.2	-40	0	-6	0.5	2.8	8
48	1	0.40	7.6	930	0.06	325	3.1	35.3	53
	5	0.55	7.6	1 070	0.06	337	4.7	35.7	76
	5-1	0.15	0	140	0	12	1.6	0.4	23
Mean		0.039	-0.100	75.5*	-0.0022	0.9	1.83*	0.72	2.25
+S.D.		+0.070	+0.885	+93.3	+0.0044	+8.2	+1.91	+1.94	+13.41

The differences for the other 6 metals are not significant. However, the variability of the Zn results is quite large.

As a check on the reproducibility of the method, Table 4 and Table 5 contain the results of replicate determinations on moss and soil samples, respectively, for all metals except Hg. The deviations of the replicate heavy metal concentrations from the mean values range from 3% (Mn) to 17% (Cd) for the moss, and from 3% (Pb) to 9% (Cu) for the soil. Results of replicate Hg determinations are found in Table 6a and Table 6b. The average deviation from the mean is $5.00 \pm 3.64\%$ for the moss and $5.45 \pm 4.26\%$ for the soil. The greatest deviation of any of the replicates is 12% for the moss and 13% for the soil.

The results of the orchard leaf analyses, to determine the accuracy of the methods, are given in Table 7. The obtained metal concentrations are approximately equal to the certified values for all metals except Zn.

B) Soil Results

I) Laboratory Data

Table 8 presents the metal contents, pH and LOI of all of the soil samples, arranged according to sample groups.

II) Metal to Metal and Environment Relationships

a) Correlations

Table 9 gives Pearson correlation coefficients among the soil metals, pH, LOI and distance from Thunder Bay. The majority of the correlations between the various pairs of metals

Table 4

Reproducibility of moss analysis method for all
metals except Hg

- presents results of repeated analyses of moss
sample No. 33 (the sample was analyzed in
duplicate over 6 different runs)

S.D. = standard deviation

Run No.	Sample No.	Metal Content of Moss (ppm, dry wt.)						
		Cd	Cu	Fe	Mn	Ni	Pb	Zn
	33 ₁	0.40	8.2	710	571	3.0	35.9	49
	33 ₂	determinations not conducted						
2	33 ₁	0.45	11.0	770	535	3.0	36.4	54
	33 ₂	0.35	7.6	750	535	2.9	37.5	51
3	33 ₁	0.50	8.4	750	546	2.5	38.0	54
	33 ₂	0.50	8.3	710	547	2.9	36.2	55
4	33 ₁	0.35	8.5	680	543	2.8	36.2	53
	33 ₂	0.35	8.0	670	547	3.0	38.3	52
5	33 ₁	0.55	9.9	770	548	3.5	43.5	54
	33 ₂	0.50	8.7	710	544	3.1	41.0	54
6	33 ₁	0.55	8.9	700	514	2.2	39.1	54
	33 ₂	0.55	9.4	800	548	2.5	38.7	54
Mean		0.46	8.8	729	543	2.9	38.3	53
±S.D.		±0.08	±1.0	±41	±14	±0.4	±2.3	±2
% Deviation from the Mean		±17%	±11%	±6%	±3%	±14%	±6%	±4%

Table 5

Reproducibility of soil analysis method for all
metals except Hg

- presents results of repeated analyses of soil sample
No. 39 (the sample was analyzed in duplicate over 6
different runs)

S.D. = standard deviation

Run No.	Sample No.	Metal Content of Soil (ppm, dry wt.)						
		Cd	Cu	Fe	Mn	Ni	Pb	Zn
2	39 ₁	0.65	8.9	3060	1948	4.6	38.0	94
	39 ₂	0.75	8.3	3010	1775	4.3	36.8	91
3	39 ₁	0.80	6.9	3070	2047	4.3	39.3	98
	39 ₂	0.75	7.4	3050	1875	4.0	37.8	94
4	39 ₁	0.70	7.4	3180	2007	4.4	39.9	94
	39 ₂	0.75	7.3	3030	1940	4.3	38.2	91
5	39 ₁	0.65	9.0	3005	1950	4.0	39.8	93
	39 ₂	0.60	8.3	3050	1900	4.4	37.5	93
6	39 ₁	0.80	7.1	2830	1880	4.6	38.2	95
	39 ₂	0.70	7.1	2870	1919	4.7	40.2	94
7	39 ₁	0.65	7.7	3070	1789	4.3	40.4	94
	39 ₂	0.70	7.6	3150	1760	4.0	40.7	80
Mean		0.71	7.8	3031	1899	4.3	38.9	92
±S.D.		±0.06	±0.7	±99	±90	±0.2	±1.3	±5
% Deviation from the mean		±8%	±9%	±3%	±5%	±5%	±3%	±5%

Table 6a

Reproducibility of mercury analyses in moss samples

Sample No.	Hg in Moss (ppm, dry wt.)		Mean and % Deviation from the Mean
	Determination No.		
	1	2	
2	0.032	0.027	0.030 ± 8 %
5	0.037	0.031	0.034 ± 9
7	0.050	0.049	0.050 ± 1
8	0.083	0.092	0.088 ± 5
11	0.057	0.055	0.056 ± 2
14	0.051	0.050	0.051 ± 1
15	0.048	0.056	0.052 ± 8
21	0.088	0.083	0.086 ± 5
23	0.054	0.054	0.054 ± 0
24	0.079	0.083	0.081 ± 2
25	0.047	0.038	0.043 ± 11
30	0.075	0.090	0.083 ± 9
32	0.106	0.100	0.103 ± 3
36	0.061	0.067	0.064 ± 5
45	0.123	0.120	0.122 ± 1
46	0.057	0.073	0.065 ± 12
49	0.055	0.061	0.058 ± 5
57	0.151	0.157	0.154 ± 2
61	0.142	0.133	0.138 ± 3
73	0.178	0.153	0.167 ± 8

Mean % deviation from the mean for the 20 sets of replicates
 = 5.00% ± 3.64%.

Table 6b

Reproducibility of mercury analyses in soil samples

Sample No.	Hg in Soil (ppm, dry wt.)		Mean and % Deviation from the Mean
	Determination No. 1	Determination No. 2	
2	0.255	0.252	0.254 ± 1 %
3	0.103	0.084	0.094 ± 10
4	0.046	0.054	0.050 ± 8
5	0.057	0.048	0.053 ± 9
6	0.335	0.322	0.329 ± 2
7	0.205	0.235	0.220 ± 7
8	0.371	0.403	0.387 ± 4
9	0.034	0.028	0.031 ± 10
10	0.034	0.028	0.031 ± 10
11	0.190	0.209	0.200 ± 5
12	0.170	0.131	0.151 ± 13
14	0.314	0.343	0.329 ± 4
15	0.119	0.116	0.118 ± 1
18	0.267	0.269	0.268 ± 0
20	0.288	0.250	0.269 ± 7
21	0.324	0.271	0.298 ± 9
22	0.159	0.165	0.162 ± 2
23	0.030	0.028	0.029 ± 3
24	0.419	0.426	0.423 ± 1
25	0.115	0.149	0.132 ± 13

Mean % deviation from the mean for the 20 sets of replicates = 5.45% ± 4.26%.

Table 7

Accuracy of Analyses

- as determined by repeated analysis of Standard Reference
Material 1571 - orchard leaves (U. S. Dept. of Commerce,
1971)

Actual Values = certified concentrations

S.D. = standard deviation

Run No.	Sample No.	Metal Content of Orchard Leaves (ppm, dry wt.)							
		Cd	Cu	Fe	Hg	Mn	Ni	Pb	Zn
1	OL ₁	0.15	11.2	290	0.138	92	1.4	47.2	30
	OL ₂	0.15	10.2	280	0.153	90	1.8	45.6	31
2	OL ₁	0.15	11.5	280	0.154	89	1.4	40.5	39
	OL ₂	0.20	11.0	260	0.155	87	1.4	41.7	36
3	OL ₁	0.15	11.9	290	0.137	87	1.7	42.6	44
	OL ₂	0.15	11.3	270	0.136	90	1.4	41.8	44
4	OL ₁	0.10	11.6	270	0.143	92	1.6	43.2	55
	OL ₂	0.15	12.4	270	0.150	87	1.4	43.7	48
5	OL ₁	0.15	12.5	260	0.154	95	1.6	45.9	44
	OL ₂	0.10	11.4	260	-	91	1.7	44.2	41
6	OL ₁	0.10	12.1	310	-	89	1.8	43.3	46
	OL ₂	0.15	12.8	290	-	97	1.3	43.0	47
7	OL ₁	0.15	12.2	300	-	87	1.2	42.4	35
	OL ₂	0.15	12.3	290	-	87	1.2	42.6	29
Mean		0.14	11.7	280	0.147	90	1.5	43.4	41
± S.D.		±0.03	± 0.7	±16	±0.008	±3	±0.2	±1.8	± 8
Actual Values		0.11	12	300	0.155	91	1.3	45	25
		±0.02	± 1	±20	±0.015	±4	±0.2	± 3	± 3

Table 8

Laboratory data - soil

-Sample No. corresponds to Site No. of Appendix 1

-metal contents of soil sample No. 39 represent means
(from Table 5)

LOI = loss on ignition (%)

s.n.a. = soil not available

i.s. = insufficient sample

Sample No.	ppm, dry wt.									LOI
	Cd	Cu	Fe	Hg	Mn	Ni	Pb	Zn	pH	
<u>Group I</u>										
1 s	0.40	7.7	4 370	0.27	216	3.8	52.0	45	4.4	62.8
2	0.65	4.3	3 030	0.25	961	2.7	36.7	49	4.1	76.0
3	0.25	2.7	3 430	0.10	272	2.1	21.8	23	4.2	32.9
4	0.15	1.8	2 170	0.05	58	0.9	11.1	15	3.7	26.1
5	0.10	2.4	3 160	0.05	88	1.9	20.7	17	3.9	17.8
6	0.55	3.5	7 250	0.33	1 720	3.7	59.0	80		i.s.
	1.25	3.0	2 600	0.22	97	1.9	30.0	36	3.6	86.8
8	0.75	4.1	4 270	0.39	90	2.9	47.0	59	3.6	64.6
9	0.10	15.0	6 160	0.03	901	3.4	9.3	45	4.9	6.9
10	0.20	4.9	9 980	0.03	584	5.4	11.5	53	4.8	7.9
11	0.50	4.9	2 540	0.20	37	3.3	27.9	45		i.s.
12	0.60	4.7	2 490	0.15	26	1.8	32.4	36	3.6	83.9
13	0.95	3.9	3 110	0.23	105	2.4	33.7	67	3.5	17.4
14	0.60	4.8	2 680	0.33	896	1.9	26.8	92	4.5	80.6
15	0.45	5.3	3 720	0.12	65	2.9	27.4	37	3.8	51.9
16	0.35	2.8	2 240	0.14	190	1.7	18.6	32	4.0	20.6
17	0.40	7.9	8 260	0.03	87	8.2	9.3	24	4.4	4.9
18	0.35	5.3	3 070	0.27	217	2.7	31.3	71	4.4	83.2

Sample No.	ppm, dry wt.								pH	LOI
	Cd	Cu	Fe	Hg	Mn	Ni	Pb	Zn		
19 s	s.n.a.									
20	1.05	5.3	3 810	0.26	1 287	3.3	52.4	174	4.7	67.8
21	0.50	3.8	2 570	0.29	924	2.8	24.4	47	4.1	79.8
22	0.75	3.8	1 430	0.16	161	0.9	29.7	61	4.8	81.7
23	0.05	2.6	4 190	0.03	430	1.9	11.1	29	4.8	6.1
24	0.70	4.3	2 890	0.42	213	2.1	28.8	69	4.4	77.2
25	0.35	8.6	4 190	0.13	103	4.3	19.6	53	4.3	32.9
<u>Group II</u>										
26	1.65	19.6	24 440	0.20	5 652	10.0	500	168	5.2	52.9
27	s.n.a.									
28	0.60	17.6	9 725	0.19	721	9.7	32.3	68	4.8	62.4
29	0.30	10.1	24 170	0.05	80	7.9	9.4	33	5.4	10.3
30	0.40	10.6	2 080	0.09	32	3.2	38.8	75	3.9	85.9
31	0.60	8.6	7 350	0.07	243	8.7	23.7	68	4.2	46.2
32	0.45	6.1	1 360	0.23	46	3.3	26.9	55	3.9	90.8
33	0.75	8.4	4 130	0.20	81	6.7	60.7	65	4.0	76.6
34	0.95	13.4	1 280	0.12	115	2.9	15.8	78	4.5	91.8
35	0.45	10.9	3 550	0.15	1 030	4.6	35.5	86	4.1	69.0
36	1.25	10.3	4 400	0.17	1 277	7.6	51.3	157	4.5	66.4

Sample No.	Cd	Cu	Fe	ppm, dry wt.			Pb	Zn	pH	LOI
				Hg	Mn	Ni				
37 s				s.n.a.						
38	0.60	5.4	2 180	0.28	150	4.7	29.6	55		i.s.
39	0.70	7.8	3 030	0.40	1 899	4.3	38.9	93	4.2	73.5
40	0.30	42.1	15 880	0.05	188	19.0	13.8	42	5.3	23.9
41	0.55	6.2	2 250	0.26	83	4.8	28.9	68	3.9	86.1
42				s.n.a.						
43				s.n.a.						
44	0.85	9.3	6 550	0.26	1 827	9.9	23.1	66	4.5	48.0
45	0.40	6.9	2 570	0.26	547	5.1	28.6	86	4.4	77.8
46	0.90	7.4	2 030	0.28	713	4.4	27.3	72	4.4	78.1
47	0.50	7.5	3 190	0.17	233	6.0	24.7	56	4.1	71.9
48	0.55	3.8	2 530	0.23	137	4.3	32.3	66	3.7	81.9
<u>Group III</u>										
49	1.30	13.3	1 280	0.18	1 787	5.0	43.5	155	5.0	81.0
50	1.80	31.2	3 680	0.19	142	5.0	33.8	106	4.1	87.7
51	2.90	26.6	9 070	0.28	162	14.3	32.3	121	4.6	81.6
52				s.n.a.						
53	1.05	6.1	1 020	0.12	204	2.5	20.1	103	3.9	95.4
54				s.n.a.						

Sample No.	ppm, dry wt.							pH	LOI		
	Cd	Cu	Fe	Hg	Mn	Ni	Pb			Zn	
55 s	1.25	7.1	3 390	0.13	65	3.9	24.3	61	4.1	87.0	
56	s.n.a.										
57	0.80	5.8	1 540	0.11	47	2.6	19.3	64	4.2	92.9	
58	0.95	8.3	9 770	0.20	843	7.1	55.7	109	4.4	56.3	
59	0.80	7.7	3 020	0.32	708	4.5	67.4	107	4.2	86.0	
60	0.80	10.1	4 890	0.16	490	6.9	25.1	102	4.7	80.0	
61	1.20	9.5	4 240	0.27	463	5.0	61.0	131	6.4	64.9	
62	0.80	14.8	15 780	0.09	527	16.1	33.7	89	4.3	33.5	
63	0.70	18.3	13 800	0.18	736	17.1	41.7	129	4.2	53.6	
64	0.65	15.8	8 990	0.18	179	10.9	30.8	93	4.6	75.1	
65	s.n.a.										
66	s.n.a.										
<u>Group IV</u>											
67	s.n.a.										
68	0.80	8.9	3 720	0.28	595	5.4	67.6	107	4.2	78.4	
69	0.30	11.4	5 890	0.04	323	4.1	25.8	64	5.1	11.7	
70	0.25	9.7	27 000	0.22	2 635	2.2	50.1	53	4.6	63.0	
71	0.20	3.3	5 230	0.03	906	3.5	10.1	64	5.6	6.3	
72	s.n.a.										

Sample No.	ppm, dry wt.					Ni	Pb	Zn	pH	LOI
	Cd	Cu	Fe	Hg	Mn					
73 s	0.70	9.1	3 370	0.23	400	4.1	63.7	85	4.2	80.9
74	0.50	3.1	1 780	0.10	44	1.8	21.9	22	4.0	23.5
75	1.45	8.4	4 270	0.21	80	4.1	57.6	95	3.9	51.7
76	1.10	28.2	8 460	0.32	124	6.5	45.8	58	3.8	63.8
77	s.n.a.									
78	0.10	12.9	22 130	0.04	664	3.4	11.2	53	4.9	8.8
79	0.30	16.3	8 040	0.10	307	9.4	44.9	64	5.0	29.4
80	1.05	10.5	4 100	0.22	72	4.0	108.7	62	3.8	71.3
81	0.05	3.4	11 580	0.02	134	4.8	10.3	24	5.9	4.8
82	0.25	3.5	1 170	0.07	145	1.7	26.4	35	3.8	17.7
<u>Group V</u> 83	s.n.a.									
84	0.50	6.0	1 250	0.06	83	1.1	17.6	45	4.0	94.5
85	s.n.a.									
86	0.35	5.1	1 340	0.10	46	1.9	20.0	66	4.3	94.1
87	s.n.a.									
88	0.10	8.0	12 930	0.02	100	10.6	13.5	41	5.0	9.3
89	0.40	7.3	11 750	0.04	1 686	6.6	15.5	45	4.7	11.9
90	0.30	7.6	9 440	0.12	217	6.9	17.4	38	4.4	32.7

Sample No.	Cd	Cu	Fe	ppm, dry wt.		Ni	Pb	Zn	pH	LOI
				Hg	Mn					
91 s				s.n.a.						
92	0.15	4.0	4 920	0.12	158	4.7	23.5	42	4.3	71.2
93	0.25	5.4	1 480	0.10	29	3.4	14.2	28	4.0	91.3
94	0.40	8.6	7 230	0.14	65	4.2	31.5	36	4.2	78.1
95	0.70	5.9	5 000	0.08	27	5.3	29.3	33	3.9	25.8
96	0.75	9.0	7 970	0.08	69	10.6	42.0	77	4.1	45.0
97	0.60	14.4	4 660	0.18	86	3.6	48.4	66	3.8	67.6
98				s.n.a.						
99	1.15	6.2	2 460	0.23	79	3.8	41.1	72	3.8	84.9
100	0.10	3.4	9 680	0.05	827	5.2	13.2	38	4.5	11.8
<u>Group VI</u>										
101				s.n.a.						
102	1.95	28.8	10 230	1.43	2 250	17.0	90.5	402	5.8	59.0
103	0.55	32.4	13 550	5.8	684	14.8	95.1	243	4.8	45.7
104	1.00	6.2	3 030	0.48	81	4.3	75.0	89	3.5	82.3
105	0.90	39.8	6 210	0.16	624	4.3	70.5	148	4.5	40.0

	Cu	Fe	Hg	Mn	Ni	Pb	Zn	Soil pH	Soil LOI	Cover	Distance from Thunder Bay
Cd	0.52 ***	-0.17 ***	0.49 ***	0.06	0.27 **	0.45 ***	0.63 ***	-0.15	0.49 ***	0.20 *	-0.28 *
Cu		0.31 **	0.14	0.07	0.56 ***	0.24	0.42 ***	0.13	0.14	0.22 *	-0.27 *
Fe		-0.26 **		0.11	0.49 ***	-0.09	-0.07	0.41 ***	-0.45 ***	-0.08	-0.08
Hg				0.22 *	-0.03	0.57 ***	0.45 ***	-0.27 **	0.62 ***	-0.04	-0.12
Mn					0.17	0.06	0.46 ***	0.30 **	-0.05	0.10	-0.11
Ni						0.10	0.35 ***	0.24 *	-0.14	0.07	0.04
Pb							0.50 ***	-0.20 *	0.40 ***	-0.05	-0.20
Zn								0.17	0.44 ***	0.31 ***	-0.24
Soil pH									-0.37 ***	0.10	-0.09
Soil LOI										0.33 **	-0.13
Cover											-0.09

are positive and significant, the exceptions being those involving Mn (significant with Hg only). Zinc exhibits the largest and most consistent correlations with other metals. Soil pH is significantly positively correlated with Fe, Mn and Ni, and negatively with Hg and Pb. Soil LOI is significantly positively correlated with Cd, Hg, Pb and Zn, and negatively with Fe and pH. Canopy cover has significant positive correlations with Cd, Cu, Zn and soil LOI. Finally, correlations of distance from Thunder Bay with metal content are negative for all metals but Ni, but are significant only for Cd and Cu.

b) Multiple Regression Analyses of the Effect of Distance and Cover

Multiple linear regression analyses were performed to determine the effect of distance from Thunder Bay and canopy cover on the metal contents of the soil. The regression equations can be constructed from the information given in Table 10, using the form of the linear equation printed on the page facing the table.

b_1 and b_2 are partial regression coefficients for the effect of distance and cover, respectively, in which the effect of the other variable is controlled for. The significance of each b value was determined by the F-test with 1 and $n-k-1$ degrees of freedom, (where k = the number of variables in the equation = 2).

The square of the multiple regression coefficient (r^2) is the "coefficient of determination". It represents the amount of the variation in metal content that is due to the combined

Table 10

Values required to construct
overall equations for linear multiple regression of metal
content of soil with distance from Thunder Bay and canopy
cover

- the various constants and ratios are explained on p. 61

Form of the equations -

Metal content (ppm, dry wt.) = regression constant
+ b_1 X(distance in km)
+ b_2 X (assigned cover value)

S.E. = standard error

Sample size (n) = 56 (excludes Ignace and Marathon data)

+ = simple r

Significance of b_1 , b_2 , F ratio:

* = $p \leq 0.05$
** = $p \leq 0.01$
*** = $p \leq 0.001$

Metal	Regression Constant	b ₁ (Dist.) ± S.E.	b ₂ (Cover) ± S.E.	Multiple r	r ²	F ratio	Standard Error of Estimate	95 % Confidence Interval (in ppm, dry wt.) for Distance = 25, Cover = 2
Cd	0.82	-0.005* ±0.002	0.039 ±0.049	0.30	0.09	2.6	0.485	0.77 ± 0.97
Cu	10.57	-0.052* ±0.026	0.699 ±0.588	0.31	0.10	2.8	5.84	10.67 ± 11.68
Fe	7.812	-17.2 ±26.1	-317 ±566	0.11	0.01	0.3	5.624	6.749 ± 11.248
Kg	0.197	-0.0004 ±0.0004	-0.009 ±0.009	0.18	0.03	0.9	0.088	0.169 ± 0.176
Mn	653.8	-3.30 ±3.99	no relationship	-0.11 ⁺	0.01	—	864	572 ± 1.728
Ni	6.31	no relationship	-0.158 ±0.346	-0.06 ⁺	0.00	—	3.45	6.00 ± 6.90
Pb	63.0	-0.445 ±0.302	-0.699 ±6.564	0.20	0.04	1.1	65.2	50.5 ± 130.4
Zn	78.0	-0.262 ±0.152	2.938 ±3.305	0.27	0.07	2.0	32.8	77.3 ± 65.6

effects of distance and cover (maximum = 1).

An "F-value" (not given in the table) was determined for each variable by the equation:

$$F = \left(\frac{b_1 \text{ or } 2}{SE} \right)^2$$

The "F-ratio" in the table is the ratio of the two F-values. The significance of the multiple regression coefficient was determined by testing the F-ratio with $k(=2)$ and $n-k-1$ degrees of freedom. This represents the significance of the equation as a whole.

The standard error of estimate (SEE) represents the "average" standard error that would result if the equation were used to predict values of the soil metal content. In order to determine the 95% confidence interval of a predicted value, the SEE is multiplied by a factor determined from a 2-sided t-test ($\alpha = 0.025$) with $n-1$ degrees of freedom. Printed on the table are 95% confidence intervals for the predicted value of the metal contents of the soil at a distance of 25 km from the city in any direction, assuming a cover value of 2 (30%).

Table 10 reveals that cover does not have a significant effect on the soil content ^{for} ~~of~~ any of the metals. The effect of distance, however, is significant for Cd and Cu. Also of note are the large 95% confidence intervals.

III) Soil - Moss Relationships

Table 11 contains the mean metal concentrations of 3 different sample groups, divided according to soil LOI. The All Sites column gives the mean contents of the moss and soil samples from all sites. The Organic Soil Sites column gives the mean contents of samples from sites where soil LOI $> 50\%$, but where the soil did not consist of rotting wood. The Mineral Soil Sites column presents the mean contents from sites > 30 km from Thunder Bay in which soil LOI $< 50\%$. All significant differences are indicated on the table, although at present we are only examining differences between soil and moss values.

When all sites are considered, soil content is significantly higher than moss content for Fe, Hg, Mn and Ni. When only organic soil sites are considered, Cd, Fe, Hg, Ni and Pb are all significantly higher in the soil. Finally, when only mineral soil sites are considered, the concentrations of Cd, Fe, Ni, Pb and Zn in the soil are significantly higher than they are in the moss.

In Table 12, the ratios of soil metal content to moss metal content for the same groups are presented. These were calculated from the mean concentrations given in Table 11. Examining first the ratios calculated from the data for all sites, it is apparent that the moss and soil contents are approximately equal for Cd, Cu, Pb and Zn, while the soil content is somewhat higher for Hg, Mn, and Ni. Soil Fe content is very much higher (about 5-X) than the moss content.

	All Sites 82	Organic Soil Sites 97	Mineral Soil Sites 110
Mean Distance (km.)			
Cover	2.33 ± 1.34	2.12 ± 1.36	1.69 ± 1.01
Soil pH	4.36 ± 0.54	4.17 ± 0.36	4.52 ± 0.60
Soil LOI (%)	56.3 ± 29.6	73.7 ± 10.8	19.9 ± 12.5
Moss			
Sample Size (n)	80	33	26
Soil			
Sample Size (n)		33	26
Metals: (mean ± S.D.)			
Cd	0.64 ± 0.46	0.57 ± 0.20	0.54 ± 0.15
Cu	8.5 ± 5.7	8.3 ± 2.0	8.7 ± 4.5
Fe	5 792 ± 5 440	1 023 ± 713	1 097 ± 1 515
Hg	0.162 ± 0.094	0.092 ± 0.045	0.075 ± 0.030
Mn	462 ± 748	320 ± 147	279 ± 204
Ni	5.0 ± 3.3	3.1 ± 1.4	3.3 ± 2.9
Pb	36.9 ± 55.2	33.9 ± 12.3	34.2 ± 9.4
Zn	67 ± 35	70 ± 32	69 ± 29

Table 12

Ratios of soil metal content to moss metal content

All Sites: where both moss and soil were obtained

Organic Soil Sites: loss on ignition (LOI) >50% and substrate not composed of rotting wood

Mineral Soil Sites: LOI < 50% and sites >30 km from city

Ratio >1 = soil content > moss content

Ratio <1 = soil content < moss content

Significant differences between mean soil and moss concentrations (from Table 11):

* = $p \leq 0.05$
** = $p \leq 0.01$
*** = $p \leq 0.001$

	Mineral Soil Sites	All Sites	Organic Soil Sites
Sample Size (n)	26	82	33
Metal:			
Cd	0.63***	1.00	1.35***
Cu	0.95	0.97	1.02
Fe	6.93***	5.24***	4.72***
Hg	1.03	1.72***	2.53***
Mn	1.49	1.60*	1.38
Ni	1.76***	1.47***	1.47***
Pb	0.58**	1.03	1.26***
Zn	0.64***	0.93	1.13

When all 3 columns are viewed simultaneously, some trends are apparent. The soil/moss ratios for Cd, Hg, Pb and Zn increase as soil LOI increases, while the ratios for Fe and possibly Ni decrease. The Cu and Mn ratios do not change appreciably.

Pearson correlation coefficients between soil and moss metal content for the same 3 groups are found in Table 13. For the mineral soil sites, there are significant positive correlations between soil and moss content for Cu, Fe and Ni, while the correlations are apparently negative for Hg, Mn, Pb and Zn. Considering all sites, all correlations are positive, with those for Cd, Cu, Fe, Ni, Pb and Zn being significant. All correlations for the organic soil sites are also positive, but only Cu, Fe, Mn and Pb are significant.

On examining Table 13 as a whole, trends are again apparent for several metals. For Cu and Ni, the correlation decreases as the soil organic content increases; while for Hg, Mn, Pb and perhaps Zn, the correlation increases as the soil organic content increases. These results agree with the soil/moss ratio trends in Table 12.

More information on the relationship between soil and moss metal concentration is contained in the histograms presented in Figure 9. They indicate that in Region 1 samples (Marathon) the ratios of soil metal content to moss metal content are the highest of all regions for all metals except Ni, while in Region 4 samples (Ignace) these ratios are the lowest. They are in fact < 1 (i.e. soil content $<$ moss content) for Cd, Cu, Pb and Zn. Trends for Hg, Mn and Ni are not apparent. The Fe ratio

	Mineral Soil Sites	All Sites	Organic Soil Sites
Sample Size (n)	26	82	33
Metal:			
Cd	0.07	0.48***	0.19
Cu	0.82***	0.60***	0.28*
Fe	0.33*	0.23*	0.52***
Hg	-0.06	0.10	0.16
Mn	-0.09	0.14	0.35*
Ni	0.68***	0.38***	0.17
Pb	-0.18	0.30**	0.44**
Zn	-0.11	0.18*	0.18

Figure 9

Histograms showing regional trends in metal content
(ppm, dry wt.) of moss and soil

- Region 1: Town of Marathon, Ontario, 200 km east of Thunder Bay (includes all of sample Group VI; sample size (n) = 5 for moss, 4 for soil)
- Region 2: from urban limits of Thunder Bay to a distance of 30 km from the city, mean distance = 20 km (includes portions of sample Groups II - V; n = 27 moss, 22 soil) ("proximate" samples)
- Region 3: from 50 - 137 km from the city, mean distance = 75 km (includes portions of sample Groups II - V; n = 22 moss, 18 soil) ("distant" samples)
- Region 4: north-east of town of Ignace, Ontario, 200 km north-west of Thunder Bay (includes entire sample Group I; n = 25 moss, 22 soil)

M = moss S = soil

Samples between 30 and 50 km from Thunder Bay are not included.

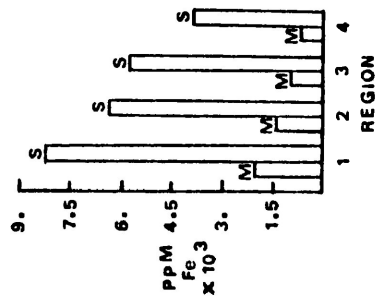
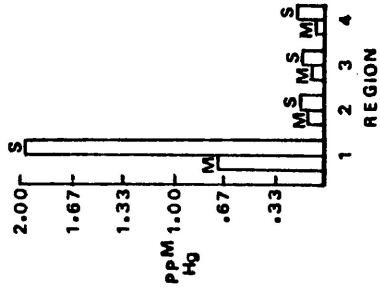
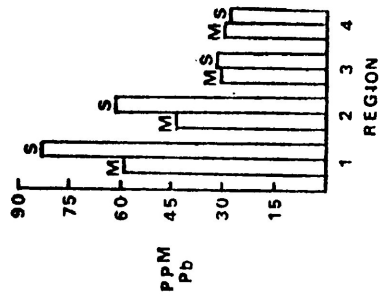
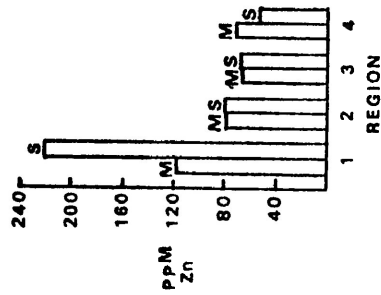
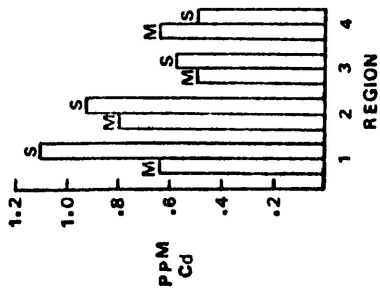
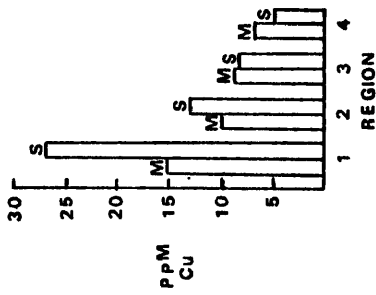
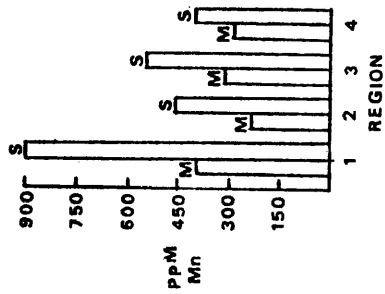
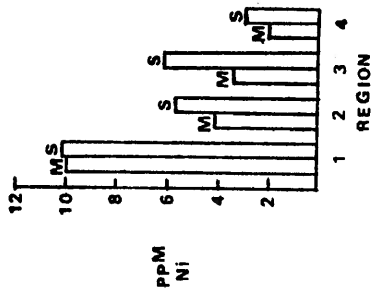

remains relatively constant.

C) Moss Results

I) Laboratory Data

The metal contents of all of the moss samples, arranged according to groups, are found in Table 14.

II) Mean Results According to Sample Groups

The mean metal content of the 6 sample groups are presented in Table 15. Although the moss concentrations are of primary interest, soil and site data are also given. Because of the possible influence of canopy cover on metal content, significant differences among the mean % cover of the various groups are indicated.

The highest concentrations of all metals except Cd are found in the Marathon samples. Mercury content, in particular, is much higher than around Thunder Bay. Regarding Thunder Bay area samples, the highest amounts of heavy metals are present in those from the area south-west of the city, while those collected east of the city contain the next highest amounts. Samples collected north and west of the city exhibit similar metal contents that generally are the lowest of the Thunder Bay area groups. The exception is the rather high Fe content of the north samples. The Ignace samples contain the lowest amounts of all metals except (in some cases) Cd, Mn and Zn.

The mean concentrations for the Sibley samples are given in Table 16.

Table 14

Laboratory data - moss

-Sample No. corresponds to Site No. of Appendix 1

-metal contents of moss sample No. 33 represent means
(from Table 4)

() indicates probable contamination - result
not used in computations

Sample No.	Cd	Cu	ppm, dry wt.		Mn	Ni	Pb	Zn
			Fe	Hg				
<u>Group I</u>								
1	0.90	7.6	830	0.08	109	2.5	34.5	199
2	0.60	5.7	570	0.03	217	1.5	24.6	58
3	0.45	5.4	790	0.05	164	2.4	31.6	73
4	0.60	4.5	670	0.06	160	1.9	31.3	140
5	0.45	4.0	310	0.03	166	1.0	23.0	48
6	0.50	4.9	600	0.06	218	2.2	28.1	61
7	0.45	6.2	860	0.05	192	2.1	28.4	63
8	0.45	9.9	910	0.09	209	2.0	34.6	54
9	0.35	7.7	1 530	0.06	575	3.1	36.3	163
10	0.50	6.0	500	0.09	404	2.4	25.3	80
11	1.60	6.5	530	0.06	163	1.8	23.3	54
12	0.60	5.8	460	0.07	179	0.9	25.1	35
13	0.55	6.4	500	0.07	384	1.1	22.7	47
14	0.35	5.7	660	0.05	394	1.9	30.8	40
15	0.50	6.0	530	0.05	456	1.9	32.0	52
16	0.50	5.8	540	0.05	430	2.4	46.3	34
17	0.50	7.0	550	0.05	216	1.8	22.1	78
18	0.60	5.9	420	0.05	497	1.8	22.1	40

Sample No.	ppm, dry wt.							
	Cd	Cu	Fe	Hg	Mn	Ni	Pb	Zn
19	0.85	6.9	710	0.07	270	1.9	27.7	52
20	1.25	7.2	550	0.08	285	2.6	33.6	100
21	0.95	7.2	630	0.09	467	1.7	27.0	76
22	0.90	8.1	620	0.06	222	1.4	29.6	41
23	0.65	8.0	750	0.05	249	1.3	33.0	75
24	0.40	6.4	820	0.08	230	2.2	32.6	56
25	0.50	9.1	1 450	0.04	384	3.1	29.0	49
<u>Group II</u>								
26	0.80	11.7	1 930	0.08	257	4.0	69.6	73
27	0.90	9.0	800	0.06	91	2.9	36.4	50
28	0.70	14.3	1 240	0.10	258	4.1	42.2	69
29	0.60	6.3	990	0.09	80	2.6	35.9	54
F	0.55	7.1	1 150	0.08	75	3.9	36.3	59
30	0.55	7.1	570	0.08	225	2.3	33.2	53
31	0.50	5.8	630	0.07	291	3.7	37.4	67
F	0.50	5.4	660	0.07	279	3.5	38.4	52
32	0.65	6.7	600	0.10	140	2.7	33.4	64
F	0.80	7.0	650	0.10	148	2.6	33.4	48
33	0.45	8.8	730	0.09	543	2.9	38.3	53
34	0.60	9.7	800	0.11	81	7.0	42.4	144
35	0.45	15.8	2 590	0.08	399	7.6	35.8	64

Sample No.	Cd.	Cu.	Fe	ppm, dry wt.		Ni	Pb	Zn
				Hg	Mn			
36	0.70	7.1	780	0.06	305	2.2	28.4	77
F	0.70	7.7	860	0.06	301	4.0	28.0	73
37	0.65	9.2	1 130	0.13	325	3.4	36.5	67
38	0.45	7.7	730	0.13	269	2.7	22.7	49
F	0.50	7.6	770	0.12	277	4.6	27.4	62
39	0.35	7.5	760	0.10	596	3.0	36.1	109
40	0.50	(27.8)	8 340	0.05	172	(16.2)	30.2	81
F	0.55	28.2	8 530	0.05	179	21.8	28.5	85
41	0.50	11.7	3 000	0.08	150	7.8	35.9	51
F	0.50	11.4	2 960	0.08	150	11.9	35.2	142
42	0.40	5.0	820	0.07	371	2.5	24.0	45
43	0.45	7.3	1 520	0.10	375	3.7	36.4	68
44	0.55	9.0	930	0.06	99	3.9	39.6	44
F	0.55	6.8	890	0.06	93	4.4	42.4	42
45	0.55	12.1	1 850	0.12	480	6.1	21.9	67
46	0.50	9.0	1 340	0.07	335	4.2	24.3	42
47	0.30	8.2	1 000	0.08	209	2.8	27.5	57
48	0.40	7.6	930	0.06	325	3.1	35.3	53
F	0.55	7.6	1 070	0.06	337	4.7	35.7	76
49	0.60	7.1	520	0.06	275	2.4	24.4	55
<u>Group III</u>								
50	2.05	16.3	3 760	0.23	246	11.3	75.2	136

Sample No.	Cd	Cu	Fe	ppm, dry wt.		Ni	Pb	Zn
				Hg	Mn			
51	1.40	11.2	1 280	0.09	93	3.4	46.5	84
52	1.75	9.7	1 390	0.20	92	3.4	55.0	96
53	1.10	(45.9)	1 390	0.21	508	3.2	60.1	139
54	1.15	16.7	2 470	0.12	129	9.0	22.4	92
55	1.45	17.1	1 170	0.18	161	5.2	48.5	102
56	0.35	8.5	860	0.06	149	3.1	23.6	56
57	1.00	10.6	1 330	0.15	168	4.3	44.4	83
58	0.55	6.7	480	0.07	531	2.8	22.2	67
59	0.65	12.8	1 510	0.25	596	3.5	118.0	104
60	0.65	16.0	3 930	0.19	589	7.5	33.0	104
61	0.80	11.1	1 420	0.14	612	3.6	42.4	94
62	0.65	13.0	860	0.10	554	3.0	28.5	82
63	0.55	7.0	970	0.10	154	3.3	33.5	69
64	0.55	10.4	1 000	0.16	287	2.8	26.0	79
65	0.65	11.0	1 730	0.25	472	2.7	43.9	94
66	0.60	8.8	810	0.13	62	3.7	50.8	96
<u>Group IV</u> 67	0.50	10.7	2 090	0.08	352	6.1	49.5	72
68	0.45	8.0	720	0.08	302	3.0	40.0	72

ppm, dry wt.

Sample No.	Cd	Cu	Fe	Hg	Mn	Ni	Pb	Zn
69	1.10	8.6	1 430	0.09	205	2.7	47.4	75
70	0.50	11.6	3 490	0.11	526	4.2	70.8	60
71	0.70	9.9	980	0.15	125	4.2	59.5	83
72	0.95	9.7	1 340	0.10	710	4.4	19.9	87
73	0.55	(85.8)	1 060	0.17	307	5.3	65.8	140
74	0.65	8.9	710	0.10	164	3.0	44.3	59
75	0.65	9.1	990	0.16	380	3.3	60.0	83
76	0.55	11.5	2 390	0.13	261	4.5	34.1	87
77	0.50	6.6	440	0.06	243	2.2	32.5	75
78	0.65	6.9	450	0.06	221	2.5	43.0	62
79	0.70	6.9	520	0.07	33	2.5	35.7	55
80	0.45	8.4	670	1.10	289	2.1	43.7	57
81	0.45	6.7	1 130	0.08	58	2.4	31.4	45
82	0.60	11.7	500	0.10	1 015	2.6	35.1	96
<u>Group V</u> 83	0.65	9.8	1 410	0.09	123	3.1	44.5	64
84	0.70	14.7	1 510	0.17	216	4.3	61.0	79
85	0.65	9.9	810	0.07	210	2.2	29.6	89
86	0.60	13.4	890	0.10	168	7.3	34.0	79

ppm, dry wt.

Sample No.	Cd	Cu	Fe	Hg	Mn	Ni	Pb	Zn
87	0.50	(20.0)	910	0.10	123	(14.3)	32.1	68
88	0.35	12.5	1 160	0.07	249	7.9	48.9	55
89	0.40	11.0	620	0.06	224	4.3	21.9	59
90	0.40	9.0	740	0.15	370	3.1	31.4	66
91	0.30	8.8	680	0.07	328	2.8	32.8	52
92	0.40	9.0	930	0.08	305	4.3	28.5	74
93	0.65	7.9	970	0.12	181	3.8	38.9	54
94	0.40	5.9	580	0.06	82	2.0	25.1	45
95	0.45	6.1	570	0.08	161	1.7	32.5	47
96	0.50	8.3	760	0.09	255	2.4	25.1	54
97	0.40	7.6	430	0.07	323	2.0	17.1	60
98	0.45	7.2	1 240	0.10	214	3.4	32.5	56
99	0.50	7.5	660	0.07	539	3.8	31.7	56
100	0.35	5.6	480	0.09	277	2.4	16.7	64
<u>Group VI</u>								
101	0.75	20.6	1 560	0.54	313	6.1	97.8	90
102	0.70	14.1	2 150	0.53	413	14.5	32.6	114
103	0.65	17.4	3 770	2.0	550	16.0	36.5	226
104	0.40	12.3	1 310	0.33	332	7.7	66.5	70
105	0.70	11.1	1 540	0.15	380	5.3	61.1	80

Table 15

Data (mean \pm S.D.) relating to moss and soil according
to sample Groups I - VI

Group I: Ignace, Ontario

Group II: transect north of Thunder Bay

Group III: area south-west of Thunder Bay

Group IV: area east of Thunder Bay

Group V: transect west of Thunder Bay

Group VI: Marathon, Ontario

S.D. = standard deviation

M = moss S = soil

Significant differences between moss cover values:

* = $p \leq 0.05$
** = $p \leq 0.01$
*** = $p \leq 0.001$

Site Nos.: 74 - 82

Direction from
Thunder Bay: east

Mean distance (km): 29.3 ± 1.7

Cover (%): 23.4 ± 12.4

Sample size (n): 9

Metal:
(mean \pm S.D.)

Cd 0.58 ± 0.09

Cu 8.5 ± 2.0

Fe 867 ± 620

Hg 0.096 ± 0.033

Mn 296 ± 291

Ni 2.8 ± 0.7

Pb 40.0 ± 9.0

Zn 69 ± 17

Corr. with Cover
0.34

0.34

0.55

0.80**

-0.03

0.70*

0.55

0.43

III) Metal to Metal and Environment Relationships

a) Correlations

Table 17 presents Pearson correlation coefficients among the heavy metals and site data for the moss samples. The correlations between the various pairs of metals are all positive except those of Mn with Cd and Pb. All are significant except those involving Mn, which only exhibits a significant correlation with Hg. None of the correlations with soil pH are significant. Correlations with soil LOI are significant for Cd, Cu, Fe, Hg and Ni, though they are lower than they are for soil metal content.

The correlations of moss metal content with cover are for the most part highly significant (except Mn). Correlations with distance from Thunder Bay are negative and significant for all metals except Mn ($r = + 0.05$). Lead exhibits the highest correlation with distance, followed by Cd, Zn, Cu, Fe and Ni, in that order.

b) Moss - Cover Relationships

Table 18 compares the average metal content in moss from sites with low cover (1, or 0-20%) with the content in moss from sites with high cover (4-5, or 60-100%). The Ignace data are not included because most sites have a cover of <20%, a fact which would bias the comparison because the metal contents of the Ignace moss are relatively low. The results show that all metals except Mn are present in significantly higher amounts in samples from sites with high cover. The amount of the increase

	Cu	Fe	Hg	Mn	Ni	Pb	Zn	Soil pH	Soil LOI	Cover	Distance from Thunder Bay
Cd	0.37 ^{***}	0.22 [*]	0.42 ^{***}	-0.15	0.27 ^{**}	0.37 ^{***}	0.36 ^{***}	0.10	0.24 [*]	0.44 ^{***}	-0.36 ^{***}
Cu		0.57 ^{***}	0.61 ^{***}	0.14	0.77 ^{***}	0.44 ^{***}	0.32 ^{**}	0.11	0.27 ^{**}	0.46 ^{***}	-0.29 ^{**}
Fe			0.40 ^{***}	0.10	0.60 ^{***}	0.38 ^{***}	0.19 [*]	0.04	0.25 [*]	0.29 ^{**}	-0.23 [*]
Hg				0.17 [*]	0.42 ^{***}	0.55 ^{***}	0.46 ^{***}	0.00	0.34 ^{***}	0.56 ^{***}	-0.12
Mn					0.01	-0.05	0.13	-0.10	0.05	-0.04	0.05
Ni						0.40 ^{***}	0.31 ^{***}	0.09	0.26 [*]	0.33 ^{***}	-0.21 [*]
Pb							0.36 ^{***}	0.14	0.09	0.23 ^{**}	-0.44 ^{***}
Zn								0.07	0.08	0.33 ^{***}	-0.30 ^{**}
Soil pH									-0.36 ^{***}	0.11	-0.12
Soil LOI										0.32 ^{**}	-0.12
Cover											-0.11

	Cover <20%		Cover >60%	%Increase
Sample Size (n)	25		20	
Mean Distance from Thunder Bay (km)	42.6		36.4	
Metal: (mean ± S.D.)				
	Cd 0.55 ± 0.23	***	0.85 ± 0.44	55
	Cu 8.8 ± 2.1	***	12.1 ± 3.4	38
	Fe 1 096 ± 779	***	1 602 ± 935	46
	Hg 0.081 ± 0.017	***	0.153 ± 0.058	89
	Mn 315 ± 208		297 ± 156	-6
	Ni 3.6 ± 1.7	*	4.8 ± 2.5	33
	Pb 36.4 ± 11.7	*	42.9 ± 14.1	18
	Zn 61 ± 13	***	91 ± 25	49

over the values for the sites with low cover is highest for Hg (89%) and follows the sequence: $Hg > Cd > Zn, Fe > Cu > Ni > Pb > Mn$.

The effect of cover on the metal contents of the Ignace moss samples alone is shown in Table 19. This presents the results of a simple linear regression. The only metals for which an increasing cover results in a significant increase in metal content are Cd and Hg.

c) Moss - Distance Relationships

Table 20 gives Pearson correlation coefficients between metal content and distance from Thunder Bay for the 4 sample groups in the Thunder Bay area. Cadmium and Pb are negative and significant for all groups except Group IV (east of the city). The Group IV correlations are, in fact, slightly positive. Other significant correlations with distance (negative, unless otherwise stated) involve Mn (positive correlation) and Ni in the Group III (south-west) samples; Hg and Zn (both positive) in the Group IV (east) samples; and Cu, Fe, Ni and Zn in the Group V (west) samples.

The relationship with distance irrespective of sample group is illustrated in Table 21. Again, the moss results are of primary interest, but soil results have also been calculated. The mean metal concentrations of samples < 30 km from the urban limits of Thunder Bay ("proximate" samples) are compared with the means of samples > 50 km from the city ("distant" samples). The mean concentrations of all metals except Mn are higher

Table 19

Values required to construct
equations for simple linear regression of metal content
of *P. schreberi* with canopy cover for Ignace (Group I)
samples

- the various constants and ratios are explained on p. 61

Form of the equations -

Metal content (ppm, dry wt.) = regression constant
+ b X (assigned
cover value)

S.E. = standard error

Sample size {n} = 25

Significance of b and r:

* = p \leq 0.05
** = p \leq 0.01
*** = p \leq 0.001

Metal	Regression Constant	b (Cover) ± S.E.	r	r ²	Standard Error of Estimate	95% Confidence Interval (in ppm, dry wt.) for Cover = 2
Cd	0.353	0.1621 *** ±0.0403	0.64***	0.41	0.230	0.677 ± 0.475
Cu	6.00	0.304 ±0.236	0.26	0.07	1.35	6.61 ± 2.76
Fe	737	-25.8 ±50.1	-0.11	0.01	286	686 ± 590
Hg	0.049	0.0069* ±0.0027	0.46*	0.22	0.0157	0.063 ± 0.032
Mn	281	4.7 ±23.0	0.04	0.00	131	290 ± 270
Ni	1.96	0.021 ±0.108	0.04	0.00	0.62	2.00 ± 1.28
Pb	30.1	-0.41 ±0.99	-0.09	0.01	5.67	29.3 ± 11.7
Zn	66.5	2.37 ±7.25	0.07	0.00	41.4	71.2 ± 84.8

Group No.	II	III	IV	V
Sample Size (n)	24	17	16	16
Direction from Thunder Bay	north	south, south-west	east	west
Mean Distance (km)	36.9	36.8	31.9	68.4
Cover (%)	41.6±15.6	55.8±19.0	23.8±10.2	45.0±13.6
Metal: Cd	-0.63***	-0.79***	0.30	-0.52*
Cu	-0.16	-0.25	0.13	-0.78***
Fe	-0.16	-0.26	0.02	-0.50*
Hg	-0.12	-0.06	0.55*	-0.25
Mn	0.28	0.47*	0.18	0.23
Ni	0.05	-0.45*	0.20	-0.44*
Pb	-0.61***	-0.52*	0.16	-0.54*
Zn	-0.17	-0.38	0.54*	-0.67**

		Moss		Soil	
		Proximate	Distant	Proximate	Distant
Sample Size (n)		27	22	22	18
Mean Distance from Thunder Bay (km)		20	75	20	75
Metal:					
(Mean ± S.D.)					
	Cd	0.79 ± 0.40	*** 0.50 ± 0.16	0.92 ± 0.65	* 0.60 ± 0.33
	Cu	9.9 ± 3.1	* 8.6 ± 2.0	13.0 ± 7.9	** 8.2 ± 3.3
	Fe	1 393 ± 1 047	* 944 ± 377	6 392 ± 6 743	5 759 ± 3 932
	Hg	0.107 ± 0.047	* 0.092 ± 0.031	0.165 ± 0.084	0.160 ± 0.080
	Mn	235 ± 138	318 ± 157	459 ± 1 236	544 ± 611
	Ni	4.1 ± 2.2	3.4 ± 1.1	5.7 ± 3.4	6.1 ± 3.2
	Pb	43.4 ± 12.8	*** 30.5 ± 10.7	61.1 ± 105.4	31.8 ± 14.9
	Zn	78 ± 26	65 ± 22	79 ± 31	67 ± 34
Cover %		43.0 ± 17.8	36.4 ± 12.6		

in the proximate than in the distant samples. The difference is significant for Cd, Cu, Fe, Hg and Pb. (For the soil, only Cd and Cu are significantly higher in the proximate samples, while both Mn and Ni concentrations are apparently higher in the distant samples.)

Scattergrams of the Cd, Cu, Pb and Zn concentrations of Thunder Bay area moss samples plotted against distance from the city are given in Figures 10 - 13. The relationships appear to be curvilinear. However, equations illustrating them were not calculated because the possible effect of cover was not taken into account.

d) Regression Analyses of the Effect of Distance and Cover

Multiple linear regression analyses were performed for the variation in metal content of *P. schreberi* with both distance from Thunder Bay and canopy cover. The analyses were conducted on the 4 directional sample groups and on the Thunder Bay area samples as a whole. In order that the equations for all 4 groups can be applied to approximately the same distance from Thunder Bay (60 km), the equations for Group V (west) are based only on the 9 sites closest to the city. The data for the 7 more distant westerly sites were included in those used to calculate apparent background concentrations. Also, the data for the 9 Sibley Peninsula sites are not included in the Group IV (east) regressions because they do not lie along the north-east transect and are all located about the same distance from the city. (Means for the

Figure 10

Scattergram of Cd content of *P. schreberi* vs. distance
from Thunder Bay (excludes Ignace and Marathon data)

vertical axis = Cd (ppm, dry wt.)

horizontal axis = Distance from Thunder Bay (km)

STATISTICAL PACKAGE FOR THE SOCIAL SCIENCES SPSSH - RELEASE 6.02

05/30/77 PAGE

SCATTERGRAMS (CREATION DATE = 05/30/77)
 FILE NAME (DOWN) CD
 SCATTERGRAM OF 10.65 23.95 37.25 50.55 63.85 77.15 90.45 103.75 117.05 130.35

Y-Label	10.65	23.95	37.25	50.55	63.85	77.15	90.45	103.75	117.05	130.35
2.05	*									
1.87										
1.70										
1.52										
1.35	*									
1.17		*								
1.00		*	*							
0.82	*			*						
0.65	**	*	*	*	*	*	*	*	*	*
0.47	*	*	*	*	*	*	*	*	*	*
0.30		*	*	*	*	*	*	*	*	*

Figure 11

Scattergram of Cu content of *P. schreberi* vs. distance
from Thunder Bay (excludes Ignace and Marathon data)

vertical axis = Cu (ppm, dry wt.)

horizontal axis = Distance from Thunder Bay (km)

STATISTICAL PACKAGE FOR THE SOCIAL SCIENCES SPSSH - RELEASE 6.02

05/30/77 PAGE

SCATTERGRAMS (CREATION DATE = 05/30/77)

FILE NAME (DOWN) CU

SCATTERGRAM OF	10.65	23.95	37.25	50.55	63.85	77.15	(ACROSS) DIST	90.45	103.75	117.05	130.35
17.10	*										
15.89		*									
14.68	*										
13.47	*										
12.26	*	*		*							
11.05	*	*	*	*	*						
9.84	*	*	*	*	*						
8.63	*	*	***	*	*	*	*	*	*	*	*
7.42	*	*	*	*	*	*	*	*	*	*	*
6.21	*	*	*2	*	*	*	*	*	*	*	*
5.00	*	*	*	*	*	*	*	*	*	*	*

17.10
15.89
14.68
13.47
12.26
11.05
9.84
8.63
7.42
6.21
5.00

Figure 12

Scattergram of Pb content of *P. schreberi* vs. distance
from Thunder Bay (excludes Ignace and Marathon data)

vertical axis = Pb (ppm, dry wt.)

horizontal axis = Distance from Thunder Bay (km)

STATISTICAL PACKAGE FOR THE SOCIAL SCIENCES SPSSH - RELEASE 6.02

05/30/77 PAGE

SCATTERGRAMS (CREATION DATE = 05/30/77)
 FILE NONAME (DOWN) P6
 SCATTERGRAM OF

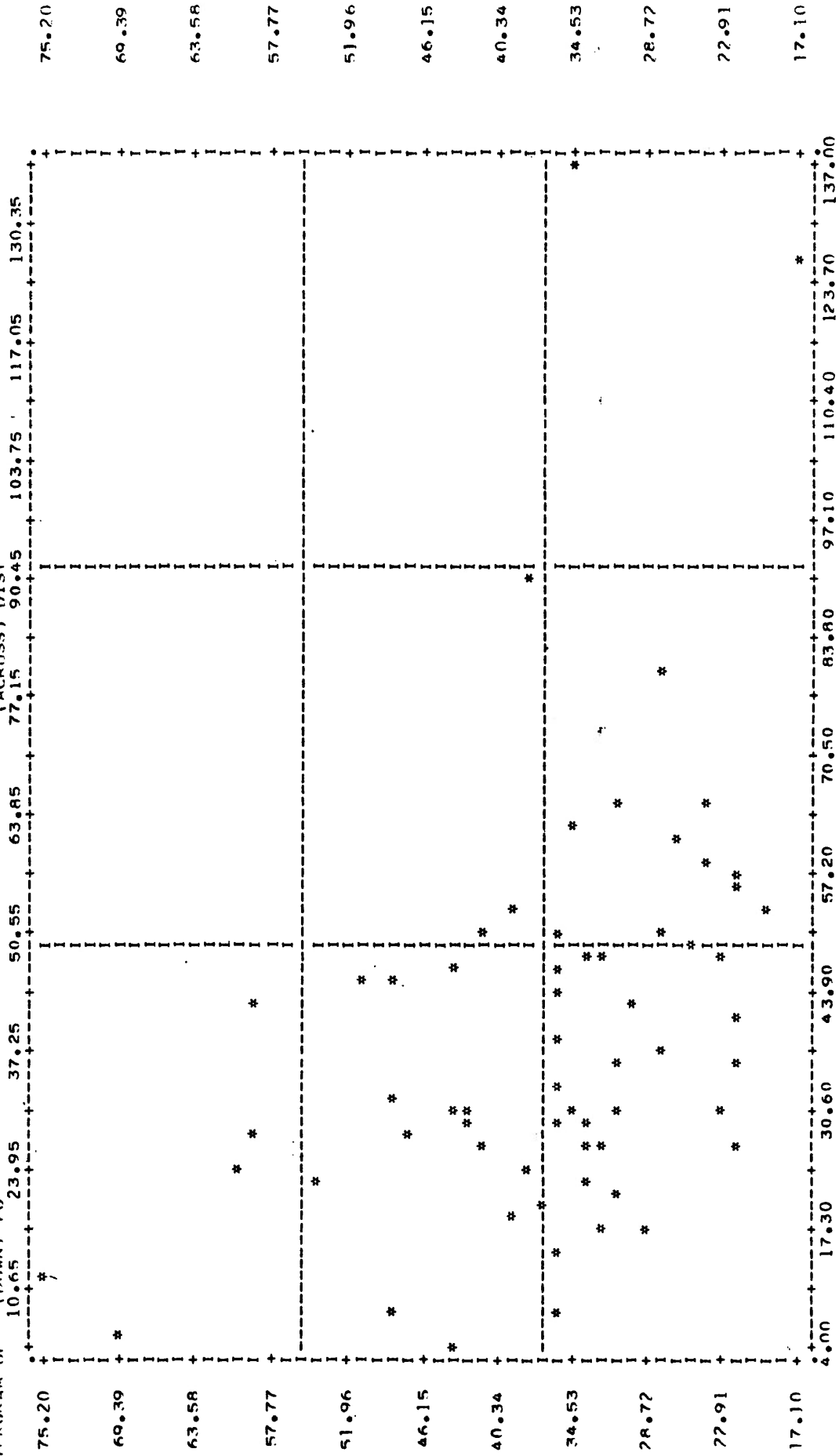

Figure 13

Scattergram of Zn content of *P. schreberi* vs. distance
from Thunder Bay (excludes Ignace and Marathon data)

vertical axis = Zn (ppm, dry wt.)

horizontal axis = Distance from Thunder Bay (km)

05/30/77 PAGE 5

STATISTICAL PACKAGE FOR THE SOCIAL SCIENCES SPSSH - RELEASE 6.02

SCATTERGRAMS (CREATION DATE = 05/30/77)

FILE NONAME (DOWN) ZN (ACROSS) DIST

SCATTERGRAM OF 10.65 23.95 37.25 50.55 63.85 77.15 90.45 103.75 117.05 130.35

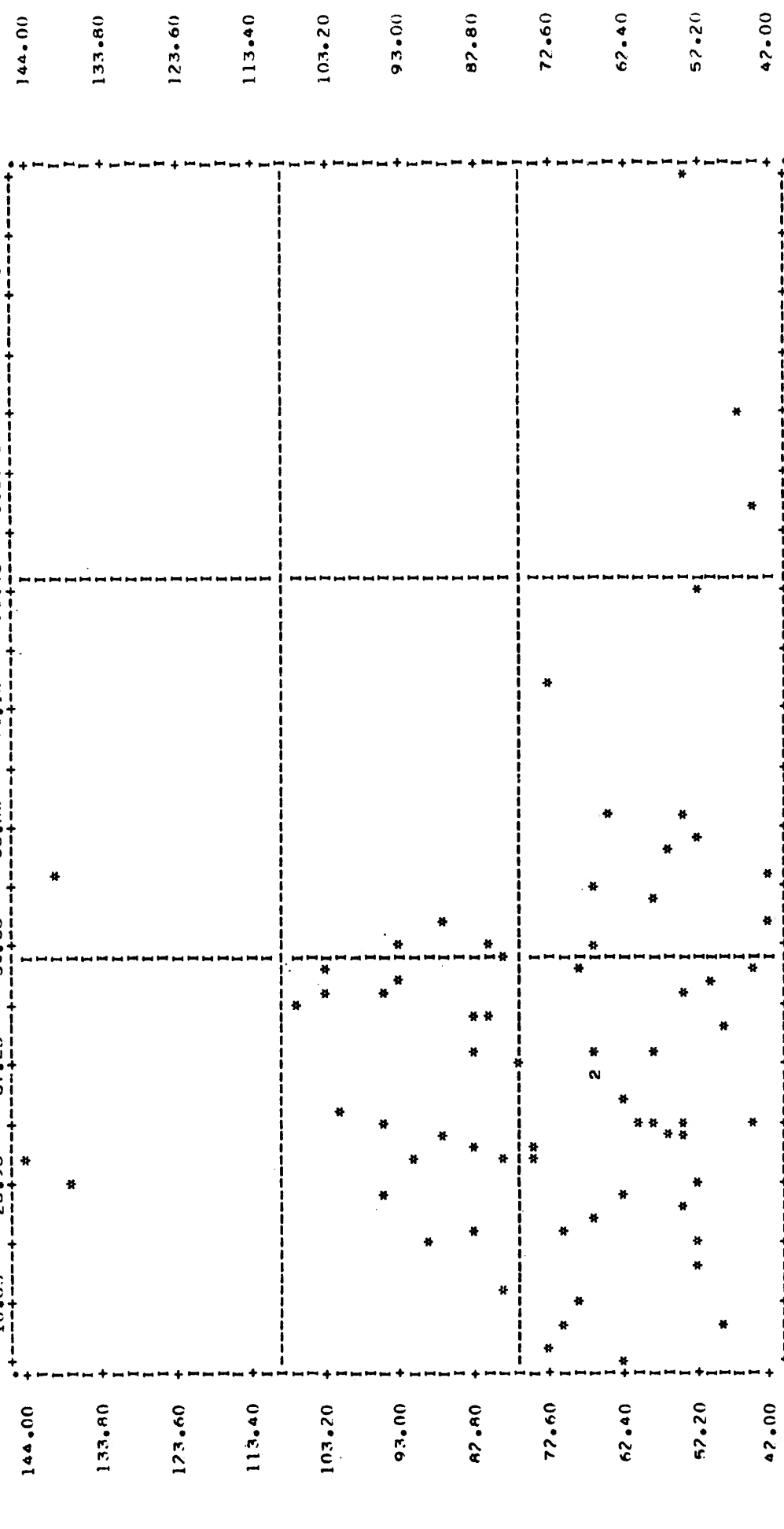

9 Sibley sites, as well as correlations with cover, may be found in Table 16.)

The results of the multiple linear regressions determined that, for the Thunder Bay area samples collectively, the moss concentration for the 4 metals Cd, Cu, Pb and Zn is significantly related to the distance from Thunder Bay. The data for these metals was subsequently reanalyzed to determine whether the relationship is, in fact, more semi-logarithmic, logarithmic, or reciprocal, than linear. These analyses were again performed on the data for the 4 directional sample groups as well as on the collective data. The "best fit" equations were selected. These equations, it is stressed, having been calculated from data of sites located within approximately 60 km of the city, are not applicable to greater distances.

1) Cadmium Regressions

The values necessary to construct the best fit multiple regression equations for Cd are presented in Table 22. The forms of the equations (whether linear, semi-log, log or reciprocal) are given on the page facing the table.

The partial regression coefficient (b_1) for the effect of distance on Cd content is negative and significant for all sample groups except that east of the city where, in fact, it is slightly positive. The partial regression coefficient for cover (b_2) is significant only for the groups south-west and west of the city. The overall best fit equation is logarithmic

Table 22

Values required to construct
best fit equations for multiple regression of Cd content
of *P. schreberi* with distance from Thunder Bay and
canopy cover

- the various constants and ratios are explained on p. 61

Forms of the equations -

Linear: Cd (ppm, dry wt.) = regression constant + b_1 X
(distance in km)
+ b_2 X (assigned cover value)

Semi-logarithmic: Log_{10} Cd = regression constant + b_1 X
(distance in km)
+ b_2 X (assigned cover value)

Logarithmic: Log_{10} Cd = regression constant + b_1 X (log_{10}
distance)
+ b_2 X (assigned cover value)

Reciprocal: Cd = regression constant + b_1 X $\frac{1}{(\text{distance})}$
+ b_2 X (assigned cover value)

S.E. = standard error

Significance of b_1 , b_2 , F ratio:

* = $p \leq 0.05$
** = $p \leq 0.01$
*** = $p \leq 0.001$

Group No. and (n)	Direction	Best Fit Relationship	Regression Constant	b (Dist.) ± S.E.	b ² (Cover) ± S.E.	Multiple r	r ²	F ratio	Standard Error of Estimate	95% Confidence Interval (in ppm, dry wt.) for Distance = 25, Cover = 2
II (24)	north	reciprocal	0.4090	2.1739*** ±0.5213	0.0166 ±0.0180	0.72	0.52	10.8***	0.1043	0.529 ± 0.215
III (16)	south-west	reciprocal	-0.1197	22.561*** ±3.9521	0.1060* ±0.0451	0.89	0.79	22.1***	0.2529	0.995 ± 0.539
IV (7)	east (excl. Sibley Penin.)	linear	0.4420	0.0055 ±0.0133	0.0552 ±0.2653	0.49	0.24	0.7	0.3041	0.692 ± 0.744
V (9)	west (to 70 km)	semi-log	-0.2344	-0.0046*** ±0.0006	0.0342* ±0.0131	0.97	0.94	44.0***	0.0391	0.524 ± 0.109
All Groups II-V (incl. Sibley and far west sites) (71)		log	-0.0355	-0.2038*** ±0.0542	0.0471*** ±0.0122	0.56	0.32	16.3***	0.1382	0.594 ± 0.384

in nature, and is very highly significant for both distance and cover. The 95% confidence interval is smallest for the transect west of the city, and largest for the area east of the city.

Figure 14 is a map of the main study area showing the predicted concentration gradient of Cd using the statistically significant best fit equations for the groups north, west, and south-west of the city. A cover value of 2 (30%) was selected for use in this and all succeeding gradient maps because it approximates the mean cover of all sites (= 2.33 , from Table 11). Distances are calculated from the nearest outer edge of the ellipse drawn in Figure 5 (p. 16). The Sibley Peninsula and Ignace concentrations are means.

The outer gradient curve in the figure (and in all succeeding maps of this type) represents the apparent background concentration at distances beyond 50 km from the city, at a mean distance of 75 km (from Table 20). The value of the next outermost curve was calculated from the regression equations for the sample groups (as were the remaining gradient curves within it). It represents the predicted Cd content of *P. schreberi* 50 km from the city. It is apparent that the concentrations at 50 and 75 km are equal. The figure also reveals that relatively high Cd values are predicted for the area south-west of the city, with a rather tight gradient being present.

When the overall regression equation (logarithmic in nature) is used to construct a predicted gradient for Cd, the result

Figure 14

Predicted concentration gradient for Cd content (ppm, dry wt.) of *P. schreberi* using best fit equations for sample Groups II (north), III (south-west) and V (west)

assigned cover value = 2 (30%)

- values for Ignace (Group I) and Sibley Peninsula (portion of Group IV) are means

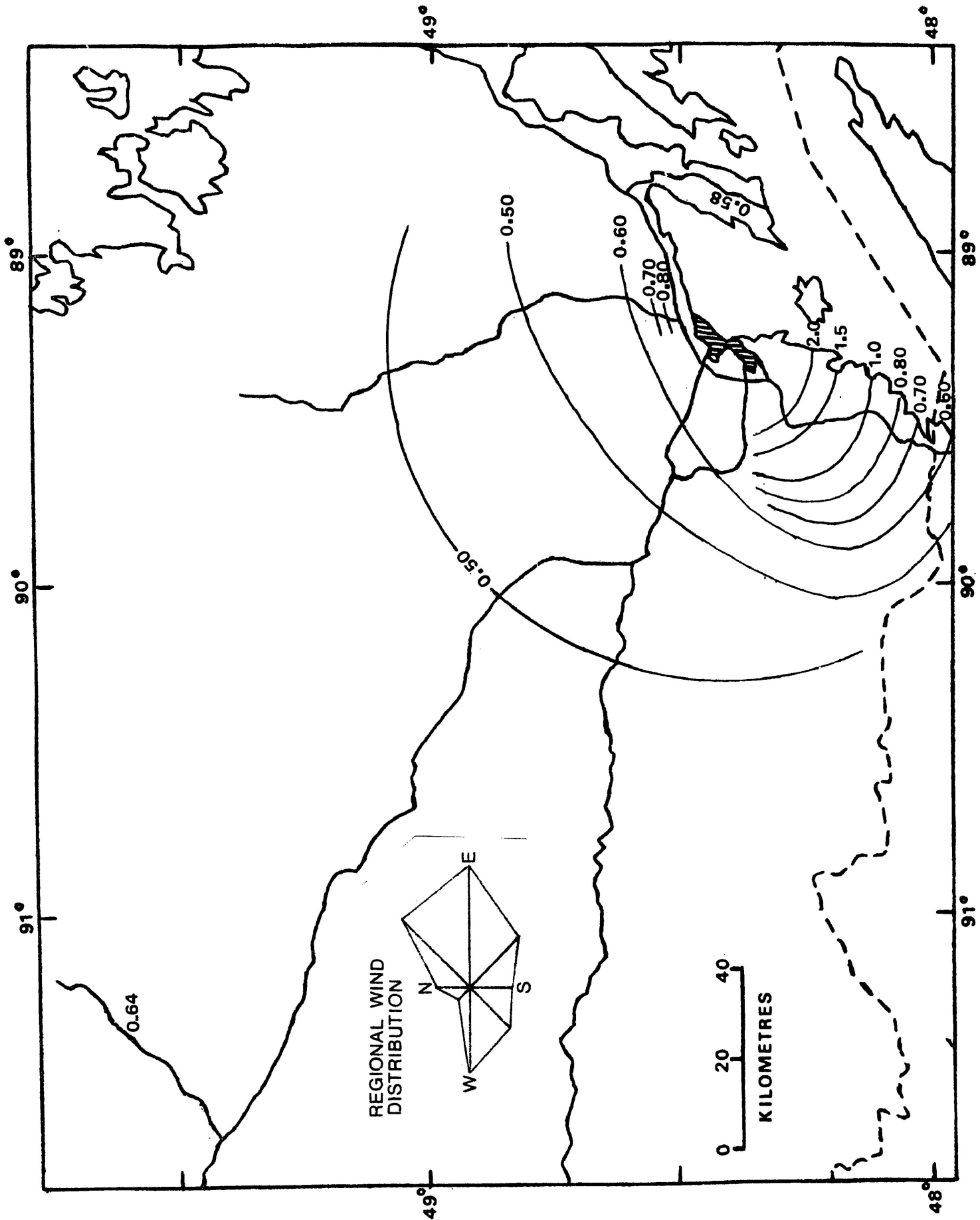

(Figure 15) is significantly different. The high values and tight gradient for the area south-west of the city are incorporated with the other data. (In order to simplify drawing of the gradient, semi-circles centred in the ellipse shown in Figure 5 (p. 6) have been drawn, rather than semi-ellipses. A correction factor has been added equal to the distance from the centre of the ellipse to its north and south borders (0.75 cm, or 9 km). The effect is to extend the curves slightly in a westerly direction, only, beyond their correct positions.)

2) Copper Regressions

The values necessary to construct the best fit multiple regression equations for Cu are found in Table 23. The effect of distance (b_1) is only significant for the overall equation (linear in nature). Cover, however, has a significant effect in the area south-west of Thunder Bay, as well as overall. The 95% confidence intervals of prediction are all of approximately the same magnitude (10 ± 5 ppm).

Figure 16, drawn using the overall equation, shows the Cu concentration gradient. In this case, the value represented by the outermost curve (a mean value, from Table 20), at a distance of 75 km, is lower than that calculated from the equation at a distance of 50 km. The Ignace mean is considerably lower, still.

Table 23

Values required to construct
best fit equations for multiple regression of Cu content
of *P. schreberi* with distance from Thunder Bay and
canopy cover

- the various constants and ratios are explained on p. 61

Forms of the equations - as for Cd (Table 21)

S.E. = standard error

Significance of b_1 , b_2 , F ratio:

* = $p \leq 0.05$
** = $p \leq 0.01$
*** = $p \leq 0.001$

Group No. and (n)	Direction	Best Fit Relationship	Regression Constant	b_1 (Dist.) ± S.E.	b_2 (Cover) ± S.E.	Multiple r	r^2	F ratio	Standard Error of Estimate	95% Confidence Interval (in ppm. dry wt.) for Distance = 25, Cover = 2
II (23)	north	reciprocal	7.280	13.301 ± 13.290	0.395 ± 0.4598	0.32	0.10	1.2	2.659	8.59 ± 5.49
III (16)	south-west	log	1.070	- 0.1372 ± 0.1322	0.0592** ± 0.0163	0.73	0.53	7.6**	0.093	9.92 ± 4.57
IV (7)	east (excl. Sibley Penin.)	linear	9.471	0.0331 ± 0.0724	- 0.5069 ± 1.4395	0.26	0.07	0.1	1.657	9.29 ± 4.03
V (8)	west (to 70 km.)	semi-log	1.123	- 0.0016 ± 0.0013	- 0.0089 ± 0.0292	0.48	0.23	0.7	0.086	11.62 ± 5.50
All Groups II-V (incl. Sibley and far west sites) (71)		linear	8.562	- 0.0263* ± 0.0111	0.8522*** ± 0.2238	0.50	0.25	11.1***	2.515	9.61 ± 5.02

Figure 15

Predicted concentration gradient for Cd content (ppm, dry wt.) of *P. schreberi* using overall best fit equation

(combines data for sample Groups II, III and V)

assigned cover value = 2 (30%)

- values for Ignace (Group I) and Sibley Peninsula (portion of Group IV) are means

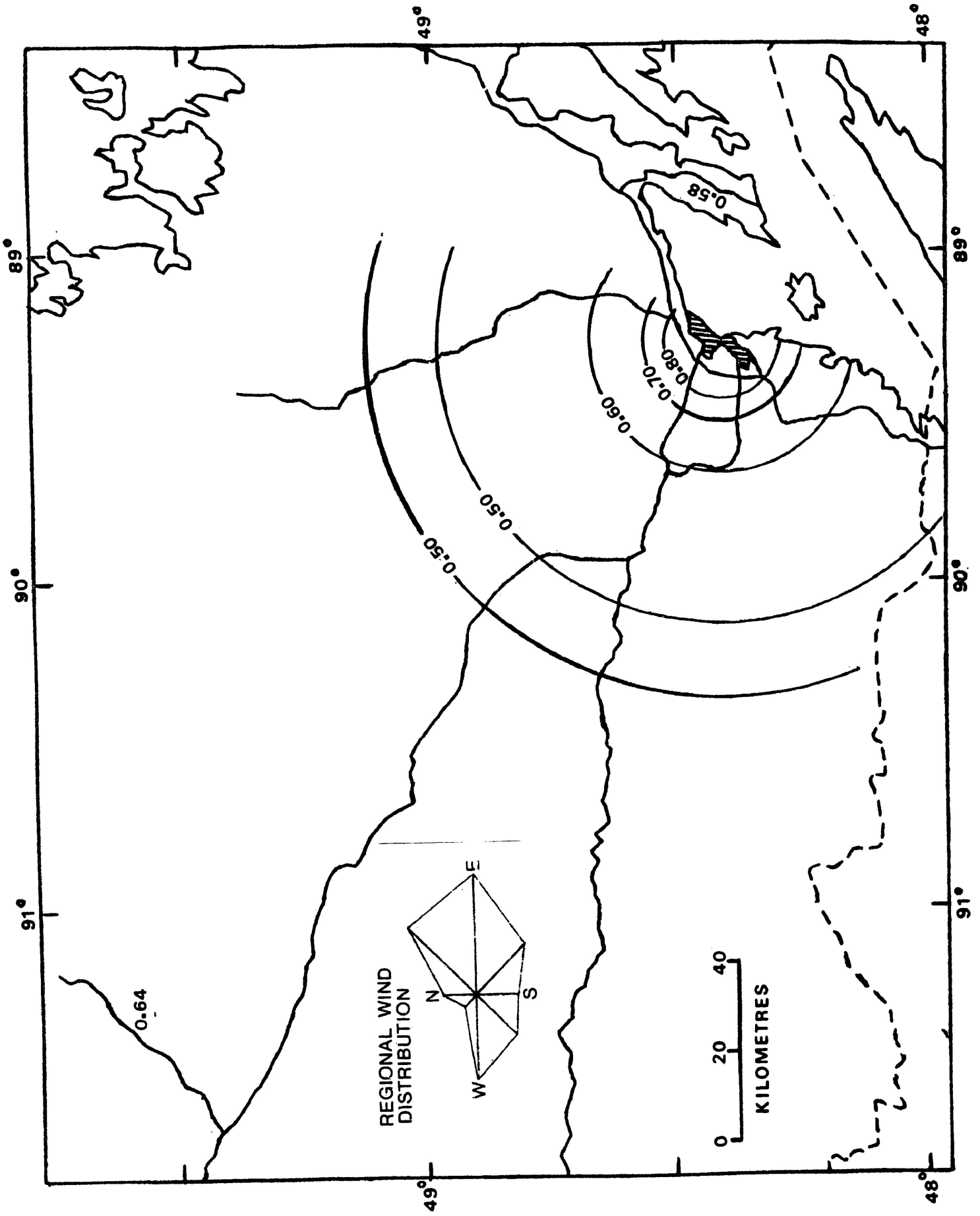
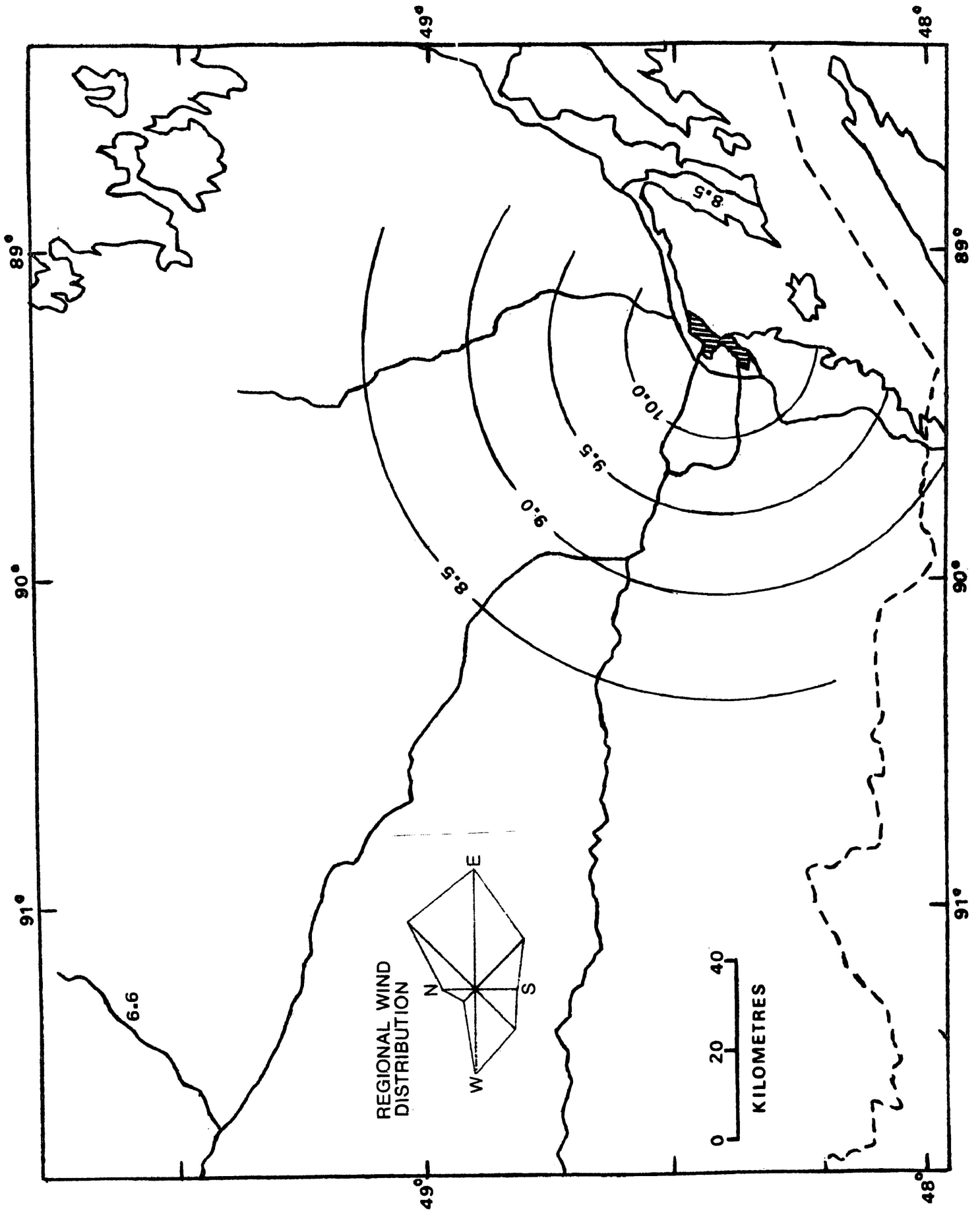

Figure 16

Predicted concentration gradient for Cu content (ppm, dry wt.) of *P. schreberi* using overall best fit equation
(combines data for sample Groups II, III and V)

assigned cover value = 2 (30%)

- values for Ignace (Group I) and Sibley Peninsula (portion of Group IV) are means



3) Iron Regressions

The linear multiple regression equations for Fe may be prepared from the data in Table 24. The overall relationship of Fe content of *P. schreberi* with distance is not significant. Therefore, an attempt to achieve a better fit by testing log, semi-log and reciprocal relationships was not made. None of the sample group equations are significant for distance, either. There is, however, a significant positive relationship with cover for the south-west area, and for the overall data. The 95% confidence intervals are large for all groups except for that west of the city.

4) Mercury Regressions

The overall multiple linear regression for Hg, given in Table 25, is also not significant for distance, nor are the group regressions. The effect of cover is again significant in the area south-west of Thunder Bay, and overall. The 95% confidence intervals are reasonably uniform, being in the range of 0.10 ± 0.07 ppm for a site 25 km from the city, with a cover of 30%.

5) Manganese Regressions

The overall linear regression for Mn is not significant with distance (Table 26). Relationships with distance for the other metals have so far been negative (except for the region east of the city). The Mn relationship, however, is positive for all groups, and significant for the areas south-west and west

Table 24

Values required to construct
equations for linear multiple regression of Fe content
of *P. schreberi* with distance from Thunder Bay and
canopy cover

- the various constants and ratios are explained on p. 61

Form of the equations:

$$\text{Fe (ppm, dry wt.)} = \text{regression constant} + b_1 X \\ \text{(distance in km)} \\ + b_2 X \text{ (assigned cover value)}$$

S.E. = standard error

+ = simple r

Significance of b_1 , b_2 , F ratio:

* = $p \leq 0.05$
** = $p \leq 0.01$
*** = $p \leq 0.001$

Group No. and (n)	Direction	Regression Constant	b_1 (Dist.) ± S.E.	b_2 (Cover) ± S.E.	Multiple r	r^2	F ratio	Standard Error of Estimate	95% Confidence Interval (in ppm, dry wt.) for Distance = 25, Cover = 2
II (24)	north	1.651	-8.63 ±11.70	no relationship	0.16*	0.03	—	1.044	1.435 ± 2.160
III (26)	south west	1.081	19.01 ±18.54	371.2* ±156.0	0.61	0.37	3.6	885	1.348 ± 1.886
IV (8)	east (excl. Sidley Penin.)	1.930	42.48 ±47.85	1.057.6 ±951.2	0.54	0.29	0.6	1 090	876 ± 2 667
V (9)	west (to 70 km.)	1.382	-9.96 ±4.17	-12.5 ±91.1	0.75	0.56	3.1	269	1 108 ± 620
All Groups II-V (incl. Sidley and far west sites) (71)		1.103	-6.53 ±3.66	169.6* ±75.8	0.35	0.12	4.5*	875	1 278 ± 1 750

Table 25

Values required to construct
equations for linear multiple regression of Hg content
of *P. schreberi* with distance from Thunder Bay and
canopy cover

- the various constants and ratios are explained on p. 61

Form of the equations -

$$\text{Hg (ppm, dry wt.)} = \text{regression constant} + b_1 X \\ \text{(distance in km)} \\ + b_2 X \text{ (assigned cover value)}$$

S.E. = standard error

Significance of b_1 , b_2 , F ratio:

* $p \leq 0.05$
** $p \leq 0.01$
*** $p \leq 0.001$

Group No. and (n)	Direction	Regression Constant	b_1 (Dist.) \pm S.E.	b_2 (Cover) \pm S.E.	Multiple R	r^2	F ratio	Standard Error of Estimate	95% Confidence Interval (in ppm, dry wt.) for Distance = 25, Cover = 2
II (24)	north	0.082	-0.00005 \pm 0.00028	0.0024 \pm 0.0042	0.16	0.03	0.3	0.023	0.086 \pm 0.048
III (16)	south west	0.058	-0.00006 \pm 0.00086	0.0279** \pm 0.0072	0.75	0.56	7.5**	0.041	0.112 \pm 0.087
IV (8)	east (excl. Sibley Penin.)	0.072	0.00137 \pm 0.00111	-0.0086 \pm 0.0222	0.67	0.45	1.2	0.025	0.089 \pm 0.061
V (9)	west (to 70 km.)	0.032	0.00006 \pm 0.00055	0.0240 \pm 0.0120	0.68	0.46	2.2	0.035	0.082 \pm 0.081
All Groups II-V (incl. Sibley and far west sites) (71)		0.065	-0.00009 \pm 0.00015	0.0170*** \pm 0.0031	0.57	0.32	15.8***	0.035	0.097 \pm 0.070

Table 26

Values required to construct
equations for linear multiple regression of Mn content of
P. schreberi with distance from Thunder Bay and canopy
cover

- the various constants and ratios are explained on p. 61

Form of the equations -

$$\text{Mn (ppm, dry wt.)} = \text{regression constant} + b_1 X \\ \text{(distance in km)} \\ + b_2 X \text{ (assigned cover value)}$$

S.E. = standard error

Significance of b_1 , b_2 , F ratio:

* = $p \leq 0.05$
** = $p \leq 0.01$
*** = $p \leq 0.001$

Group No. and (n)	Direction	Regression Constant	b_1 (Dist.) \pm S.E.	b_2 (Cover) \pm S.E.	Multiple r^2	F ratio	Standard Error of Estimate	95% Confidence Interval (in ppm, dry wt.) for Distance = 25, Cover = 2
II (24)	north	216.9	2.079 \pm 1.749	-4.51 \pm 26.10	0.30	1.0	142	260 \pm 294
III (16)	south- west	-61.7	8.916* \pm 3.827	5.56 \pm 32.21	0.56	2.7	183	175 \pm 390
IV (8)	east (excl. Sibley Penin.)	174.8	1.135 \pm 10.674	106.44 \pm 212.20	0.49	0.5	243	416 \pm 594
V (9)	west (to 70 km.)	77.0	2.919** \pm 0.680	19.00 \pm 14.86	0.89	9.2*	44	188 \pm 101
All Groups II-V (incl. Sibley and far west sites) (71)		301	0.272 \pm 0.773	-11.90 \pm 16.00	0.10	0.4	179	284 \pm 358

of the city. The effect of cover is nowhere significant. 95% confidence intervals are generally large. The smallest, again, is that for the transect west of the city.

6) Nickel Regressions

Nickel presents yet another case where the overall regression relationship of moss content and distance is not statistically significant (Table 27). However, the relationship south-west of the city is significant. This area also illustrates a significant positive relationship with cover, as does the overall data. The 95% confidence intervals are rather large, and only roughly of a similar magnitude (approximately 4.5 ± 4 ppm).

7) Lead Regressions

The values required to construct the best fit multiple regression equations for Pb are found in Table 28. The effect of distance from Thunder Bay on the Pb content of *P. schreberi* is significant for samples from north and south-west of the city, as well as for the overall data. Cover has no significant effect. The confidence intervals of predicted concentrations 25 km from the city show a fair degree of uniformity (approximately 35 ± 25 ppm).

Figure 17, constructed using the best fit equations for the sample groups north, west and south-west of the city, represents the predicted Pb concentration gradient. In this case, the values for the outermost curve, the next outermost curve, and the Ignace

Table 27

Values required to construct
equations for linear multiple regression of Ni content
of *P. schreberi* with distance from Thunder Bay and
canopy cover

- the various constants and ratios are explained on p. 61

Form of the equations -

$$\text{Ni (ppm, dry wt.)} = \text{regression constant} + b_1 X \\ \text{(distance in km)} \\ + b_2 X \text{ (assigned cover value)}$$

S.E. = standard error

Significance of b_1 , b_2 , F ratio:

* = $p \leq 0.05$
** = $p \leq 0.01$
*** = $p \leq 0.001$

Group No. and (n)	Direction	Regression Constant	b_1 (Dist.) \pm S.E.	b_2 (Cover) \pm S.E.	Multiple r^2	F ratio	Standard Error of Estimate	95% Confidence Interval (in ppm, dry wt.) for Distance = 25, Cover=2
II (24)	north	3.408	0.006 \pm 0.022	0.065 \pm 0.324	0.07	0.1	1.76	3.70 \pm 3.64
III (16)	south west	5.045	-0.091* \pm 0.040	0.916* \pm 0.339	0.73	6.8*	1.92	4.61 \pm 4.09
IV (8)	east (excl. Sibley Penin.)	4.249	-0.058 \pm 0.059	1.108 \pm 1.171	0.51	0.5	1.34	5.02 \pm 3.28
V (9)	west (to 70 km.)	7.487	-0.016 \pm 0.033	-0.951 \pm 0.735	0.50	0.8	2.17	5.17 \pm 5.00
All Groups II-V (incl. Sibley and far west sites) (71)		3.41	-0.012 \pm 0.008	0.384* \pm 0.157	0.35	4.7*	1.76	3.88 \pm 3.52

Table 28

Values required to construct
best fit equations for multiple regression of Pb content
of *P. schreberi* with distance from Thunder Bay and
canopy cover

- the various constants and ratios are explained on p. 61

Forms of the equations - as for Cd (Table 21)

S.E. = standard error

Significance of b_1 , b_2 , F ratio:

* = $p \leq 0.05$
** = $p \leq 0.01$
*** = $p \leq 0.001$

Group No. and (n)	Direction	Best Fit Relationship	Regression Constant	b ₁ (Dist.) ± S.E.	b (Cover) ± S.E.	Multiple r	r ²	F ratio	Standard Error of Estimate	95% Confidence Interval (in ppm. dry wt.) for Distance = 25, Cover = 2
II (24)	north	reciprocal	25.22	166.70*** ±32.18	0.8077 ±1.1132	0.78	0.61	15.6***	6.438	33.5 ± 13.3
III (16)	south-vest	reciprocal	14.74	514.92* ±175.98	2.6456 ±2.0106	0.71	0.50	6.0*	11.26	40.6 ± 24.0
IV (8)	east (excl. Sibley Penin.)	linear	60.10	0.8600 ±0.6023	-26.16 ±11.97	0.79	0.62	2.0	13.708	29.6 ± 33.5
V (9)	vest (to 70 km)	semi-log	1.730	-0.0031 ±0.0020	-0.0228 ±0.0436	0.53	0.28	1.2	0.130	40.4 ± 27.7
All Groups II-V (incl. Sibley and far west sites) (71)		log	1.837	-0.2062*** ±0.0488	0.0143 ±0.0110	0.48	0.23	10.5***	0.124	37.8 ± 21.9

Figure 17

Predicted concentration gradient for Pb content (ppm, dry wt.) of *P. schreberi* using best fit equations for sample Groups II (north), III (south-west) and V (west)

assigned cover value = 2 (30%)

- values for Ignace (Group I) and Sibley Peninsula (portion of Group IV) are means

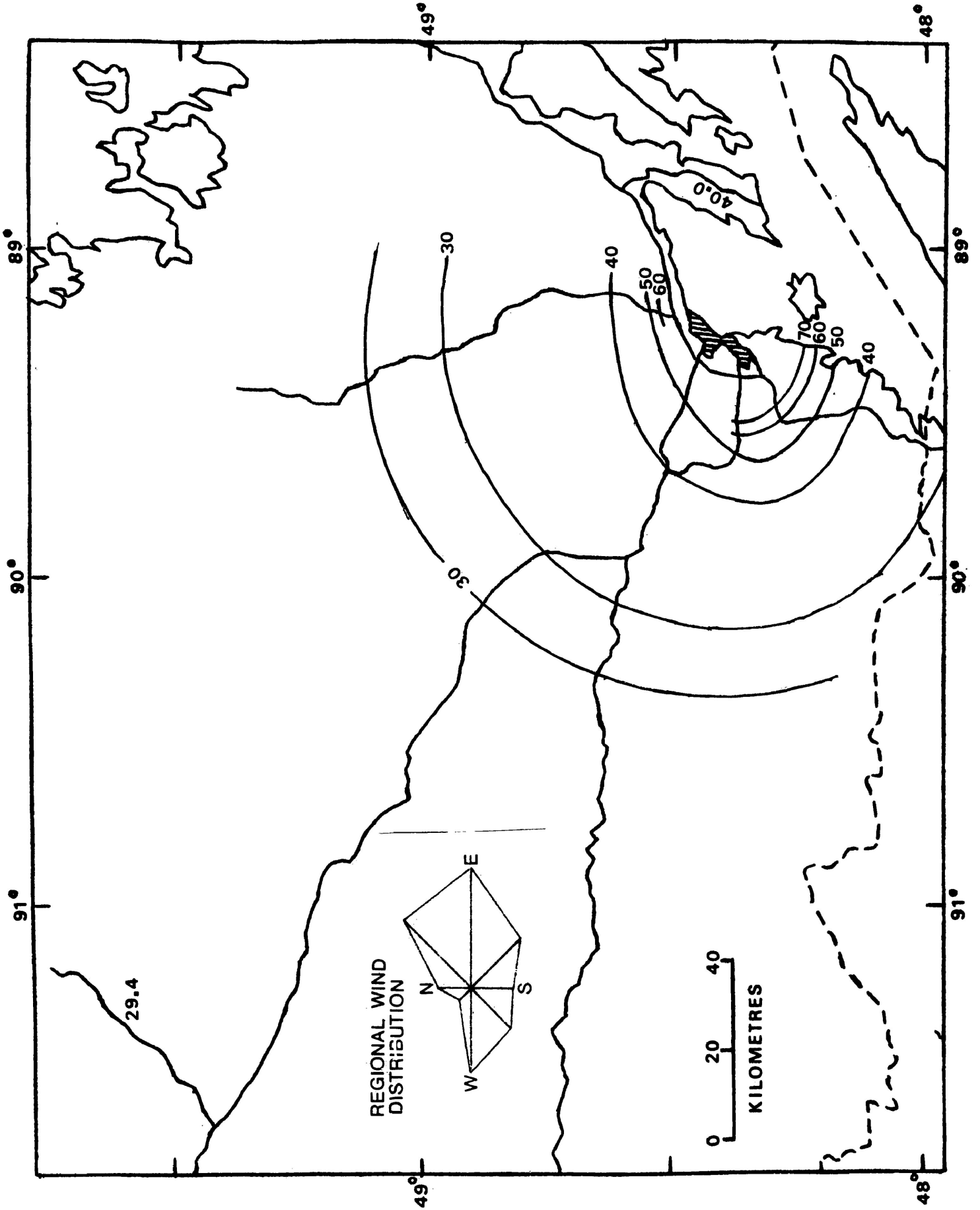

samples are all essentially equal to 30 ppm.

When the overall best fit equation (logarithmic) is used to illustrate the gradient, the result (Figure 18) does not differ appreciably.

8) Zinc Regressions

Table 29 contains the values used to construct the best fit equations for Zn. There is a significant distance effect in the area southwest of the city, and overall. The effect of cover is significant in all cases except that for the west transect. The 95% confidence intervals are generally the smallest, on a relative basis, of all of the metals. The intervals are fairly uniform, the average being approximately 70 ± 30 ppm.

Figure 19 shows the Zn concentration gradient around Thunder Bay, drawn using the best fit (semi-log) equation for the overall data. The gradient is small, with predicted values ranging from 72.5 ppm near the city to 65 ppm at a distance of 50 km. It is noteworthy that the mean Ignace value (71 ppm) is higher than the predicted 50 km value.

Figure 18

Predicted concentration gradient for Pb content (ppm, dry wt.) of *P. schreberi* using overall best fit equation (combines data for sample Groups II, III and V)

assigned cover value = 2 (30%)

- values for Ignace (Group I) and Sibley Peninsula (portion of Group IV) are means

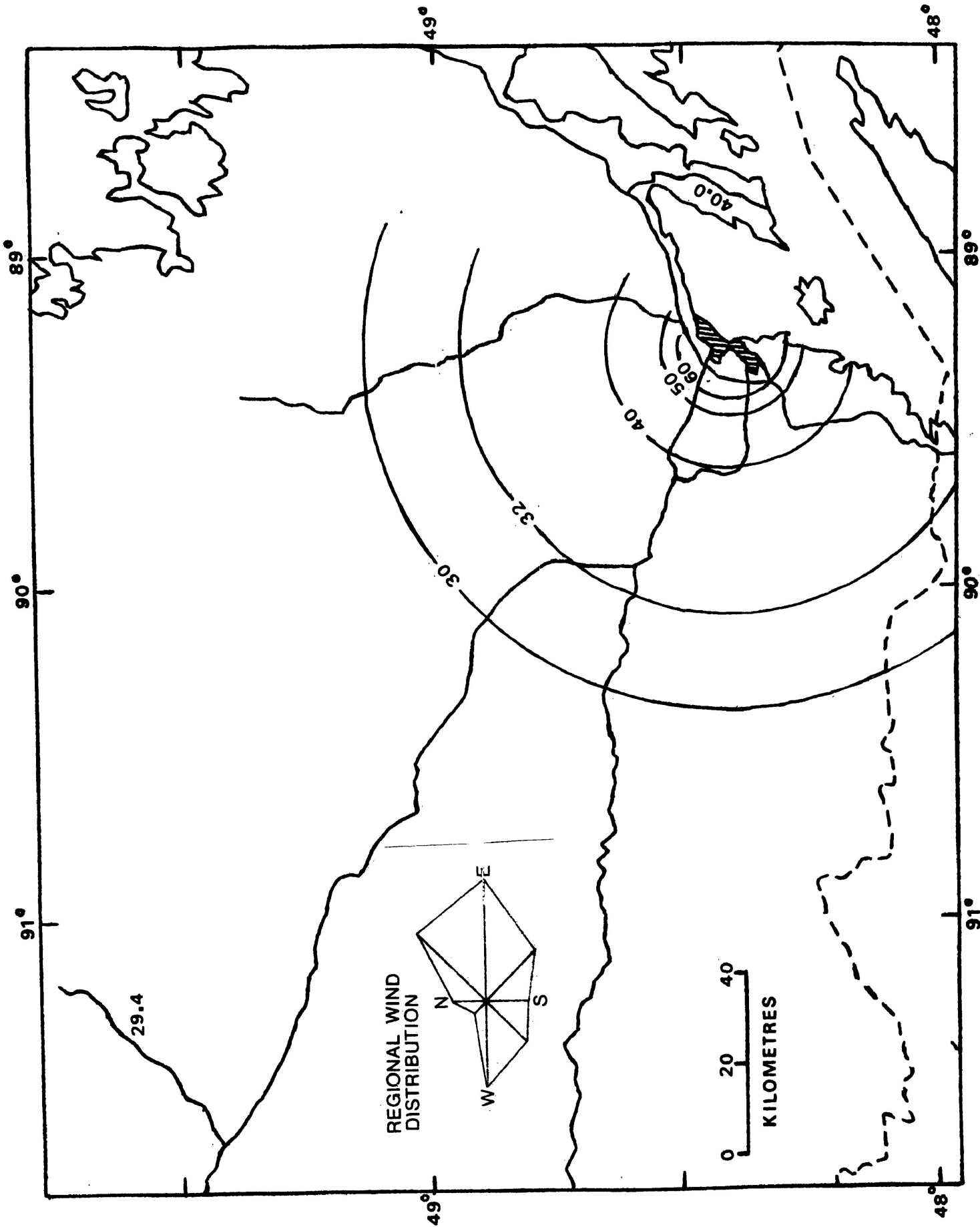

Table 29

Values required to construct
best fit equations for multiple regression of Zn content
of *P. schreberi* with distance from Thunder Bay and canopy
cover

- the various constants and ratios are explained on p. 61

Forms of the equations - as for Cd (Table 21)

S.E. = standard error

Significance of b_1 , b_2 , F ratio:

* = $p \leq 0.05$
** = $p \leq 0.01$
*** = $p \leq 0.001$

Group No. and (n)	Direction	Best Fit Relationship	Regression Constant	b_1 (Dist.) \pm S.E.	b_2 (Cover) \pm S.E.	Multiple r^2	F ratio	Standard Error of Estimate	95% Confidence Interval (in ppm, dry wt.) for Distance = 25, Cover = 2
II (24)	north	log	1.615	0.0233 \pm 0.0766	0.0554*** \pm 0.0183	0.56	4.9*	0.106	57.4 \pm 29.2
III (17)	south- west	reciprocal	48.93	489.65* \pm 178.87	7.5913** \pm 2.0435	0.83	12.9**	11.45	83.7 \pm 24.3
IV (8)	east (excl. Sibley Penin.)	log	1.827	-0.0943 \pm 0.1385	0.1263* \pm 0.0427	0.84	6.1*	0.076	88.6 \pm 36.7
V (9)	west (to 70 km.)	semi-log	1.824	-0.0018 \pm 0.0009	0.0252 \pm 0.0198	0.76	4.0	0.059	67.7 \pm 21.2
All Groups II-V (incl. Sibley and far west sites) (71)		semi-log	1.783	-0.0012 ** \pm 0.0004	0.0401*** \pm 0.0088	0.56	15.3***	0.098	68.3 \pm 31.2

Figure 19

Predicted concentration gradient for Zn content (ppm, dry wt.) of *P. schreberi* using overall best fit equation
(combines data for sample Groups II, III and V)

assigned cover value = 2 (30%)

- values for Ignace (Group I) and Sibley Peninsula
(portion of Group IV) are means

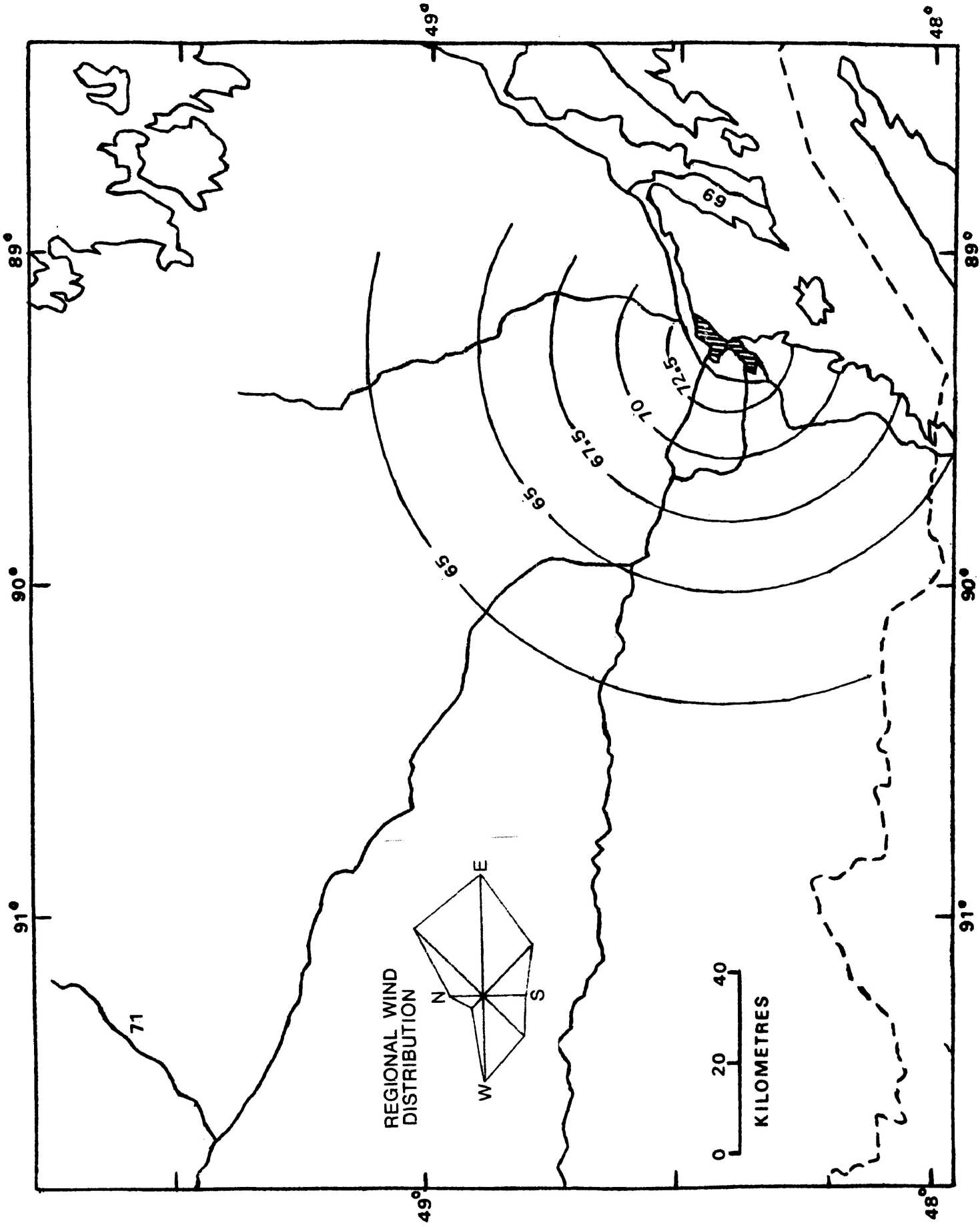

Part 4

DISCUSSION

The discussion section of this report, presented below, has been divided into the following major sections:

- A) Adequacy of Methods
- B) Soil Metal Relationships
 - I) Metal to Metal Relationships
 - II) Environmental Factors
 - III) Background Levels
 - IV) Comparison of Non-background Levels
- C) Moss Metal Relationships
 - I) Metal to Metal Relationships
 - II) Environmental Factors
 - III) Background Levels
 - IV) Comparison of Non-background Levels
- D) Soil - Moss Relationships
 - I) Ratios of Soil Content to Moss Content
 - II) Correlations Between Soil and Moss Content
 - III) Variations in Relationship with Different Degrees of Pollution
 - IV) General Comparison of Soil and Moss
- E) Distribution Patterns and Possible Sources of Metals
 - I) Comparison of Levels in Sample Groups
 - II) Discussion of Individual Metals
- F) General Discussion and Conclusions

A) Adequacy of Methods

Since the additional loss of weight incurred by oven-drying was only 2.40% (Table 2, p. 38) the air-drying procedure is deemed adequate. Oven-drying requires additional time and effort, and is thus counter-productive to the development of a simple, rapid analysis technique. One must also consider the possibility of a loss of volatile elements, especially Hg, which could occur during oven-drying.

The results of the blender test (Table 3, p. 40) show that the concentrations of the 5 min group are significantly higher than those of the 1 min group for Fe and Ni ($p \leq 0.05$). This indicates that contamination from the stainless steel blades of the blender occurs for these metals. The difference may also be due in part to more thorough digestion of the 5 min group because of finer grinding. There is a considerable amount of variability in the Zn results, although the 1 min and 5 min values do not differ significantly. However, it is felt that any contamination resulting from the usual 1 min grinding period is probably negligible.

The reproducibility of the methods (Tables 4 - 6b, pp. 43 - 49) is satisfactory, though less so for metals present in concentrations near their detection limits (e.g. Cd). When working close to the detection limit, there is increased likelihood of error due to baseline instability and background noise. To reduce this error, larger sample sizes and/or more sophisticated equipment would be required. The sample sizes used in

this study are considered to provide good overall results when all metals are considered, however.

The results of the N.B.S. orchard leaf determinations (Table 7, p. 51) indicate that the accuracy of the analyses is satisfactory for all metals except Zn. The mean Zn value of 14 determinations was 41 ppm, whereas the actual value is 25 ± 3 ppm. This apparent inaccuracy is difficult to account for. Previous experience (Rinne, 1975) had shown that Zn was perhaps the most stable and easiest to measure of all the metals studied. Certainly, the overall Zn results of this study appear reasonable. Although the Zn concentration gradient around Thunder Bay is relatively small, it has still been found to be mathematically significant (Table 29, p 139).

The Ni concentration of the orchard leaves obtained using the hydrogen ion background corrector was 1.5 ppm vs the certified value of 1.3 ± 0.2 ppm. This is an acceptable result, falling just within the possible range. It is felt that even though there may be a small amount of inaccuracy in the Ni results, this should not affect comparisons within the context of the present study (i.e. between groups).

In general, the methods developed and adopted for this study are considered to be adequate for its purposes.

B) Soil Metal Relationships

I) Metal to Metal Relationships

The pearson correlation coefficients for the soil metals (Table 9, p. 60) reveal positive and significant correlations between most pairs of metals, as expected. The correlations of Zn with other metals are especially high (except with Fe). However, the correlations of Mn with other metals are generally low, indicating that no definite relationship exists. There is a significant negative correlation between Fe and Hg, probably because Fe content is higher in mineral soils than in organic soils while the reverse situation exists for Hg.

II) Environmental Factors

a) Soil pH and LOI

Soil metal correlations with pH in Table 9 are significant for Fe, Hg, Mn, Ni and Pb. Iron, Mn and Ni decrease with decreasing pH, while Hg and Pb increase. This is in part due to the relatively high solubility of Fe, Mn, and Ni in acid solution, and the relative insolubility of Pb and Hg, which determines the extent to which these metals are leached from the surface horizon.

Related to this is the significant negative correlation between LOI and pH. If a soil metal content is positively correlated with pH, it is usually negatively correlated with LOI. This is the case for Fe, Mn and Ni. Conversely, if a metal is negatively correlated with pH, it is usually positively correlated with LOI. Such is the case for Cd, Hg and Pb.

(The relationships for Cu and Zn are not clear.) The positive correlations between LOI and Cd, Hg and Pb content are probably due in part to the fact that organic soils have more sites for adsorption of metal ions than do mineral soils (and also to the LOI - pH solubility relationship). The negative correlations between LOI and Fe (possibly Mn and Ni also) may be due to the fact that this metal exists for the most part in ore form in mineral soils (as well as to the LOI - pH solubility relationship).

The relationship between soil metal content and LOI can be further appreciated by referring to Table 13 (p. 72). This gives the ratios (calculated from the figures in Table 11, p. 67) of soil metal content to moss metal content for 3 sample groups established according to soil LOI. Since moss metal content does not differ significantly among the 3 groups (Table 11), with the exception of the low Hg content of mosses from mineral soil sites (probably due to a lower cover), any apparent ratio trends also represent actual soil content trends. Increasing ratios indicate increasing soil metal content. It can be seen that the soil contents of Cd, Hg, Pb and Zn increase with increasing soil organic content, while contents of Fe and perhaps Ni decrease. Trends for Cu and Mn are not apparent. These are essentially the same findings revealed by the correlations between metal content and LOI in Table 9.

Thus, the metal content of soils varies greatly according to pH and LOI.

b) Cover

There is a significant positive correlation between cover and soil metal content for Cd, Cu and Zn only (Table 9). However, these relationships are no longer apparent when the effect of distance from Thunder Bay is accounted for (Table 10, p. 63).

c) Distance

The correlations between soil metal content and distance from Thunder Bay are negative and significant for Cd and Cu only. These results are borne out by the multiple regression analyses (Table 10). The Cd result demonstrates, however, that a relatively high amount of Cd, apparently more so than any other metal, is entering the atmosphere from sources within the city. The Cu result may indicate, since the Cu content of moss vs. distance is significant at the 5% level only (Table 23, p. 116) that Cu pollution in the area represents a relatively long-standing situation, although not a serious one.

III) Background Levels

Regional background levels in northwestern Ontario soils are given in Table 30. When compared with results of other researchers, large variations are noted, primarily due to the different soil types encountered.

	Thunder Bay ⁺ Ontario (mean ± S.D.)	18	22	Ignace (1) Ontario (mean ± S.D.)	South-west Wales (range)	Western (3) England (mean ± S.D.)	British Columbia (4) (mean ± S.E.)	Sudbury (5) Ontario	Roven (6) (range)	Clyde Forks Ontario (mean)
Sample Size (n)		18	22			46	30			
Metal:										
Cd	0.60 ± 0.33		0.50 ± 0.30	0.4 - 0.5*	1.6 ± 0.6			0.01 - 0.7		
Cu	8.2 ± 3.3	***	4.9 ± 2.7	35*	39 ± 44			26	2 - 100	
Fe	5 759 ± 3932	*	3 900 ± 2057		43 ± 35*			11 565	7 000 - 550 000	
Hg	0.160 ± 0.080		0.191 ± 0.124			0.176 ± 0.026			0.01 - 0.3	0.16
Mn	544 ± 611		405 ± 463		92 ± 38*			168	100 - 4 000	
Ni	6.1 ± 3.2	***	2.9 ± 1.5	3*	36 ± 19			35	10 - 1 000	
Pb	31.8 ± 14.9		28.0 ± 13.9	6-16*	71 ± 55				2 - 200	
Zn	67 ± 34		53 ± 33	20 - 68*	90 ± 53				10 - 300	
Soil Type	mainly humus		mainly humus		pasture	litter and/ or humus	mineral	mineral	mainly mineral	humus
Soil pH	4.4 ± 0.6		4.2 ± 0.4		5.3 ± 0.6	5.2 ± 0.1	3.4			
Soil LOI (%)	58.5 ± 25.7		48.6 ± 31.0		10.9 ± 2.4	63.8 ± 3.7	5.6			

IV) Comparison of Non-background Levels

The metal content of soils from sites polluted by local sources of emission are found in Table 31. Values again may greatly exceed those of background. However, direct comparisons are difficult to make because soil type is so variable.

C) Moss Metal Relationships

I) Metal to Metal Relationships

The correlation coefficients for the moss metals (Table 17, p. 89) are all positive, as expected, except those of Mn with Cd and Pb. All are significant except those involving Mn, which is only significantly correlated with Hg. The low Mn correlations indicate that there is no definite relationship between the levels of this and other metals.

Groet (1976) found significant positive correlations among Cr, Cu, ^{Ni}~~Hg~~ and Zn. However, Cd correlated with Zn only. Rühling and Tyler (1970) reported that the degree of sorption by moss of Cd from mixed solutions of high concentration was much reduced from that from mixed solutions of low concentration. This suggests that Cd must "compete" with other metals for adsorption by the moss and, as Groet (1976) proposes, might explain his findings.

Rinne (1975) found a very highly significant negative correlation between Cd and Pb in mosses from contaminated sites (near roadways), again lending support to the competition theory.

Rühling and Tyler (1969) intercorrelated Cu, Zn and Pb content of *H. cupressiforme* and reported "rather good" positive

Table 31

Metal content of soils (ppm, dry wt.) from polluted areas of the present study compared with other results given in the literature

S.D. = standard deviation

References:

- | | |
|----------------------------------|----------------------------------|
| (1) results of present study | (5) Linzon <u>et al.</u> (1976) |
| (2) Goodman and Roberts (1971) | (6) Czarnowska (1974) |
| (3) Davies (1971) | (7) Burkitt <u>et al.</u> (1972) |
| (4) Hutchinson and Whitby (1974) | (8) D' Itri (1972) |

+ sampling sites < 30 km from city of Thunder Bay ("proximate" sites; Table 21, p. 98)

‡ represents available (acetic acid-extractable) metal content, only

	Thunder Bay ⁺ Ontario (1) (mean ± S.D.)	Marathon ⁽¹⁾ Ontario	South-west Wales (range)	Western (3) England (mean ± S.D.)	Sudbury (4) Ontario (range)	Toronto (5) Ontario (mean)	Warsaw (6) Poland (range)	Industria ⁽⁷⁾ Britain (range)	Clyde Fort ⁽⁸⁾ Ontario (range)
Sample Size (n)	22			12		65			
Metal: Cd	0.92 ± 0.65		25 - 193*	2.7 ± 1.0		2.3		7 - 32	
Cu	13.0 ± 7.9	28.8; 32.4	160 - 210*	131 ± 178	2 000 - 2 900	33.2	5 - 260		
Fe		10 230; 13 550			30 000 - 110 000	26 000	5 000-20 000		
Hg		1.43, 5.80							0.20 - 1.86
Mn		2 251; 684					100 - 600		
Ni		17.0, 14.8	2- 234*	55 ± 27	1 800 - 5 100	34.8			
Pb		90.5, 95.1	15- 260*	660 ± 183	50 - 80	292	5 - 110	200 - 600	
Zn		402, 243	105- 550*	396 ± 271		154	30 - 270	200 - 5 000	
Soil Type	mainly humus	humus		garden	mineral				humus
Soil pH	4.4±0.5	4.8, 5.8		6.1±0.8	2.2-3.3		6.0-7.7		
Soil LOI(%)	65.3±29.1	59.0, 45.7		13 ± 3	6 - 11				

correlations between Cu and Ni (0.61), Cu and Zn (0.56) and Cu and Pb (0.49), but a lower correlation between Zn and Pb (0.29).

II) Environmental Factors

a) Soil pH and LOI

There are no significant correlations between soil pH and moss metal content (Table 17). However, correlations with soil LOI are positive and significant for Cd, Cu, Fe, Hg and Ni. Since the moss contributes to a greater extent to the formation of organic soils than to mineral soils, this relationship is expected.

b) Cover

That cover has a considerable effect on the metal content of the moss is shown by the highly significant positive correlations for all metals except Mn (Table 17).

The actual effect of cover on the metal content of Thunder Bay area moss samples is shown in Table 18 (p. 91). The only metal not illustrating a significant increase with cover is Mn. It is noteworthy that the metals present in the lowest amounts, Cd and Hg, are most affected by cover.

A summary of the multiple regression cover relationships, which account for the effect of distance from Thunder Bay, is presented in Table 32. It can be seen that the apparent significant effect of cover on Pb content is not an actual effect. However, all other metals except Mn do increase significantly with cover.

Table 32

Summary of regression relationships between metal content of *P. schreberi* and canopy cover, with effect of distance accounted for

Significant relationships: * = $p \leq 0.05$
** = $p \leq 0.01$
*** = $p \leq 0.001$

Group No. and Direction

Metal

	II	III	IV	V	All
	North	South-west	East (excl. Sibley sites)	West (to 70 km)	
Cd		*		*	***
Cu		**			***
Fe		*			*
Hg		**			***
Mn					*
Ni		*			
Pb		**			***
Zn	***	**	*		***

The area where the effect of cover is most significant is that south-west of the city. This area contains the highest amounts of all metals, except possibly Mn (Table 15, p. 84), in the Thunder Bay area. This indicates that the higher the metal content of a region, the greater is the effect of cover on elevating the content of underlying moss.

The above hypothesis is borne out by the results of the Ignace regressions (Table 19, p. 94). The Ignace samples contain relatively low amounts of metals (Table 15), and the only metals which increase significantly with cover are Cd and Hg.

Other researchers have generally recognized the possibility of an excess accumulation of metals in mosses growing under trees. Rühling and Tyler (1973) state that, "As far as possible, all samples were taken outside the crown projection of trees and bushes". Although Groet (1976) avoided areas near the bases of trees, the canopy cover of the majority of his sites nevertheless ranged from 55 - 75%. This amount of cover may have elevated metal concentrations significantly above what levels for open sites would have been.

The observation that metal levels are considerably elevated by canopy cover would indicate that levels of essential nutrients are also elevated. That this, in fact, occurs was demonstrated by Tamm in 1953.

c) Distance

Correlations between moss metal content and distance from Thunder Bay (Table 17) are negative for all metals except Mn. They are significant for Cd, Cu, Fe, Ni, Pb and Zn. The degree of significance is $Pb > Cd > Zn > Cu > Fe > Ni$. Evidently, there are no significant local emissions of Hg. The situation for Mn is not known because of its unusual behaviour. The observation that the correlations of Cd and Pb with distance are especially high is similar to the findings of Rühling and Tyler (1973) that the greatest regional differences in metal content of Scandinavian moss exist for these metals.

The comparison (Table 21, p. 98) of the metal concentrations of moss from the "proximate" sites (<30 km from the city) with the concentrations of moss from the "distant" sites (50 - 137 km from the city) reveals that proximate content is significantly higher than distant content for Cd, Cu, Fe, Pb and Zn. This is further evidence that sources of emissions of these metals are present within Thunder Bay.

Mn content is actually significantly higher in distant than in proximate samples. This is evidence that the adsorption of Mn is decreased in the presence of higher amounts of other metals, as may occur for Cd. The reason for this may be related to the relative instability of organic chelates with Mn, such stability generally following the sequence: $Pb > Cu > Ni > Zn > Cd > Fe > Mn$ (Rühling and Tyler, 1973). (Note that Cd also forms relatively unstable organic chelates.) The above sequence is,

not surprisingly, almost identical to that given by Rühling and Tyler (1970) to represent the relative capacity of *H. splendens* to sorb and retain heavy metals (Cu, Pb > Ni > Co > Zn, Mn). It is also the approximate reverse of the order of solubility of metals in acid solution, which is generally: Mn > Zn > Fe > Cd > Co > Ni > Pb > Cu > Hg. This is quite strong evidence that metals which are more highly soluble (high oxidation potential) are less strongly retained by the moss tissue and are hence more liable to be displaced by ions of metals which are less highly acid soluble.

Groet (1976) using New York City as a point source, found a significant decrease with distance for all metals except Cd. He further determined that the relationship was more curvilinear than linear for Cr, Cu and Ni.

The curvilinear nature of the relationship in Thunder Bay area moss of Cd, Cu, Pb and Zn with distance is illustrated in Figures 10 - 13 (pp. 101-107).

A summary of the multiple regression relationships between moss metal content and distance from Thunder Bay is presented in Table 33. Here, the possible effects of canopy cover have been controlled for, so that true relationships should be apparent.

Most of the relationships are negative, as expected. However, those for the east group (except Ni and Zn) tend to be positive (though not significantly so). It is possible that more thorough testing of the area would reveal negative relationships (the present data are based on only 7 sites).

Group No. and Direction

Metal

	II	III	IV	V	All
	North	South-west	East (excl. Sibley Penin.)	West (to 70 km)	
Cd	*** reciprocal	*** reciprocal	+ linear	*** semi-log	*** log
Cu	reciprocal	log	+ linear	semi-log	* linear
Fe			+		
Hg			+		
Mn	+	*+	+	***+	
Ni		*			
Pb	*** reciprocal	* reciprocal	+ linear	semi-log	*** log
Zn	log	* reciprocal	log	semi-log	** semi-log

The area with the greatest number of significant distance relationships is that lying south-west of the city, showing that this area is relatively highly contaminated.

Manganese exhibits consistently positive distance effects, which are significant for the south-west and west groups. Similarly, Pakarinen and Tolonen (1976) found the Mn content of *Sphagnum fuscum* (Schimp.) Klinggr. to be significantly higher in north than in south Finnish samples. This tendency for Mn content to increase while ^{decreases} apparent pollution ^{suggests that adsorption} ^{of other} metals is favoured over that of Mn, and may preclude the use of moss Mn analysis in pollution surveys.

Overall, the only metals in Table 33 that are significantly related to distance are Cd, Cu, Pb and Zn. Evidently, significant correlations noted earlier for Fe and Ni are, in fact, not significant when cover effects and natural variation in metal content are accounted for. (Ni, however, is significant south-west of the city.) The nature of the best fit relationships for these 4 metals (i.e. whether linear, semi-logarithmic, logarithmic or reciprocal) is also given in the table.

In general, the nature of the relationship between metal content and distance from the primary source in any particular area may be determined by the relative locations and extent of the sources of the metal. In the case of Pb, for example, the relationship may be related to the density of motor vehicle traffic. If a transect were sampled which began adjacent to an area with a great deal of motor vehicle traffic, and then

extended away through an area of negligible vehicle traffic until the background concentration of Pb were reached, the relationship of Pb with distance would be logarithmic. This situation is analogous to that found on a much smaller scale immediately adjacent to highways, where a log (or exponential) relationship has been determined to exist for the decrease in Pb content of vegetation with increasing distance from the highway (Cannon and Bowles, 1962; Rühling and Tyler, 1968; Ward et al., 1975).

A logarithmic relationship is to be expected for the decrease in amount of deposited metals with distance from any "point" source, if the source has essentially zero height (Campbell, 1976). If, however, the source is a tall chimney, Nieboer et al. (1972) and Tomassini et al. (1976) have shown that the decrease may be accurately expressed as a linear function of the reciprocal distance from the source.

These two relationships, logarithmic and reciprocal, are actually very similar, and may be considered as variants or forms ^{of} the same general type, when compared with other possible types of relationships such as linear or semi-logarithmic. When both were applied to 4 sets of data in the present study, in all cases the curves for the 2 relationships were almost identical except that the decrease in metal content during the first few kilometers of distance for the reciprocal relationship was somewhat more pronounced.

The reciprocal relationship is the simpler to apply of the 2, and provides more information at a glance. Tomassini

et al. (1976) suggest that ideally the regression constant (i.e. concentration-axis intercept) reveals the regional background level (i.e. concentration at infinite distance). Indeed, the equations for the best fit reciprocal relationships for Cd, Cu and Pb for the group north of the city support this line of thinking quite well (intercepts (corrected for cover = 2) = 0.44, 8.1 and 26.8 respectively; compare with Table 13, p. 72). Here, there is only a small contribution of the metals by sources within the sample zone (i.e. traffic) and the city to the south can be considered a point source.

The intercepts of the best fit reciprocal relationship equations for Cd, Pb and Zn for the group south-west of the city do not equal the background values for these metals, however, being under-estimates in all cases. This is probably due to the contribution of minor sources of these elements within the sampling zone (e.g. Cd from trash incineration, Pb from vehicle exhaust, Zn from tire wear).

In general, then, if emissions originate from a relatively high elevation (tall chimney) the evidence of Nieboer et al. (1972) and Tomassini et al. (1976) suggests that the relationship with distance will be reciprocal. Also Le Blanc et al. (1974) state that a "distinct" reciprocal relationship exists near the Murdochville, Quebec copper mine and smelter. If the emission source is not significantly higher than the surrounding terrain, the relationship should be logarithmic. Further evidence of this is provided by Wallin (1976) who found that the course of the deposition curves of Hg with distance from chlor-alkali

plants (emission sites 5 to 15 m above-ground) followed an exponential (logarithmic) function. Where an entire city is being considered as a point source, however, it is difficult to predict whether the best fit relationship for any one direction will be logarithmic or reciprocal, and indeed there may be little to choose between the 2.

The best-fit relationship between metal content and distance might be linear in the case where a point source, only, does not exist, but rather a significant contribution to the atmospheric metal content is made by sources located within the sampling area as well (e.g. where traffic volume decreased linearly with increasing distance from the major source (a city), a linear relationship might be found for at least Pb). That this situation does exist to a certain extent in the area southwest of the city is indicated by the fact that the next best fit relationship (after reciprocal) for Cd, Pb and Zn in this area is a linear one.

A semi-logarithmic relationship might be present in situations lying between the two extremes of logarithmic (or reciprocal) and linear (e.g. for Cd, Cu, Pb and Zn in the transect extending west from the city).

Thus, the main determinant of the nature of the relationship between amount of metals deposited and distance is the ratio of the contributions of sources located outside of the sampling area to those located within the sampling area. If this ratio is relatively large, a log or reciprocal relationship may prevail; if small, the relationship will be linear.

If the above line of thought were applied to the overall Cd, Cu, Pb and Zn results, it would indicate that the ratio of the relative contributions of Thunder Bay sources to external (regional) sources follows the order $Cd > Pb > Zn > Cu$. (Cd is placed before Pb because the overall log equation for Cd has a better fit than that for Pb.)

The possibility arises that the direction of the prevailing wind might alter the above basic relationships. However, such is not the case. For example, a logarithmic relationship is found between the Pb content of vegetation and distance for both upwind and downwind sides of highways (Cannon and Bowles, 1962; Ward et al., 1975). The only difference is that levels are proportionately greater on the downwind side and background concentrations are found proportionately further from the highway.

From Table 33, the similarity between Cd and Pb behaviour is apparent in that their best fit equations are of the same form. This indicates similar sources and/or distribution patterns for the 2 metals, but does not preclude the possibility that high Pb levels may interfere with the adsorption of Cd by the moss.

III) Background Levels

Regional background levels for northwestern Ontario moss samples are given in Table 34. The first column presents levels in the "distant" site mosses (50 - 137 km from Thunder Bay). The second column presents levels in the Ignace (Group I) samples.

Discrepancies between the values from these 2 "background" areas make it difficult in most cases to determine a "natural"

Table 34

Background metal content of moss (ppm, dry wt.) from the present study compared with other results given in the literature

S.D. = standard deviation

References:

- | | |
|----------------------------------|----------------------------------|
| (1) results of present study | (7) Brooks (1972) |
| (2) Rühling and Tyler (1973) | (8) Mäkinen and Pakarinen (1977) |
| (3) Groet (1976) | (9) Yeaple (1972) |
| (4) Holden (1971) | (10) Huckabee (1973) |
| (5) Rasmussen and Johnson (1976) | (11) Wallin (1976) |
| (6) Goodman and Roberts (1971) | |

+ sampling sites > 50 km from city of Thunder Bay ("distant" sites; Table 21, p. 98)

Significant differences:
(Thunder Bay and Ignace)

*	= p	≤ 0.05
**	= p	≤ 0.01
***	= p	≤ 0.001

	Thunder Bay ⁽¹⁾ Ontario (mean ± S.D.)	Ignace (1) Ontario (mean ± S.D.)	Southern Scandinavia (2) (range)	Northern Scandinavia (2) (range)	Northeastern (3) United States (mean)	Northern Quebec (3)	Mt. St. Anne Quebec (3)	Cape Bon Quebec (3)	Smoky Mts. Tennessee (3)	Rural England (4)	Rural Scotland (4)	Rural Denmark (5) (mean)	South-west Wales (6) (range)	Brooks (7) (range)	Southern Finland (8) (mean)
Sample Size (n)	22	25			86	2	1	1	-			50			
Metal: Cd	0.50 ± 0.16 **	0.64 ± 0.21	0.8 - 1.5	0 - 1	0.93	0.40, 0.55	1.06	0.64	0.68	0.4	0.6	0.40	1-1.8	0.2 - 5.0	
Cu	8.6 ± 2.0 ***	6.6 ± 1.4	8 - 12	5	9.6	5.4, 5.6	9.0	7.7	9.0			10	11-15	5.4 - 2.0	
Fe	944 ± 377 **	692 ± 281	1 000	500								2 250		2 000	
Mn	318 ± 157	290 ± 128										165		80 - 310	265
Ni	3.4 ± 1.1 ***	2.0 ± 0.6	3 - 8	1.5 - 2.0	9.4	4.6, 5.0	6.0	5.1	4.4				6.5-10	2 - 15	
Pb	30.5 ± 10.7	29.4 ± 5.6	40 - 150	5 - 10	131	12, 38	123	50	107	116	91	50	50 - 65	30 - 300	28
Zn	65 ± 22	71 ± 41	80 - 110	30 - 40	62	42, 65	89	47	53			95	74 - 108	45 - 132	60
Species Analyzed	<i>Pleurozium schreberi</i>	<i>P. schreberi</i>	<i>Hylocomium splendens</i>	<i>H. splendens</i>	<i>Leucobryum glaucum</i>	<i>H. splendens</i>	<i>P. schreberi</i>	<i>H. splendens</i>	<i>H. splendens</i>			<i>Hypnum cupressiforme</i>	<i>H. cupressiforme</i>		<i>P. schreberi</i>
Sample Size	22	25			Brooks (7) (range)	Rural Maine (9) (range)	Smoky Mts. Tennessee (10) (mean)	Sweden (11) (range)							
Metal: Hg	0.092 ± 0.031	0.061 ± 0.017	0.20 - 0.40	0.05 - 0.10	< 0.05 - 2.0	< 0.05 - 0.6	0.11	0.09 - 0.15							
Species Analyzed	<i>P. schreberi</i>	<i>P. schreberi</i>	<i>H. splendens</i>	<i>H. splendens</i>			<i>Dicranum scoparium</i>	<i>H. cupressiforme</i>							

background concentration. The only metal found in nearly equal amounts is Pb (30 ppm). Concentrations of Cu, Fe and Ni in distant Thunder Bay mosses are significantly higher than at Ignace. Manganese is also apparently higher. This may indicate that effects of emissions from the city extend beyond 50 km. It may also be due in part to a general decrease in metal content of the atmosphere encountered as one proceeds in a northerly direction away from the industrialized areas of the northern hemisphere. This general decrease was noted by Rühling and Tyler (1973) in Scandinavia and by Groet (1976) in the north-east United States.

Cadmium is present in significantly higher amounts in Ignace moss (0.64 ppm) than in "distant" Thunder Bay moss (0.50 ppm). Zinc is also apparently higher in Ignace samples (71 vs. 65 ppm nearer Thunder Bay). Rühling and Tyler (1973) reported a decrease in Cd and Zn content of moss with increasing latitude. However, as reported earlier, they also found evidence (1970) that, in competition for adsorption sites on the moss, Cd "loses out" to other metals when they are present in mixed solutions of sufficiently high concentration (as may also occur for Mn). Lower concentrations of other metals at Ignace might therefore allow more of the available Cd to be adsorbed than can occur even 50 km from Thunder Bay.

Groet (1976) found that Cd concentrations were generally higher in northern New England mosses than in those from southern New England. Yet there are no apparent major Cd sources in the north. He also found that the Cd content of mosses did not

increase near urban centres, and postulates a competition for exchange sites on the adsorption complex of the moss surface, as the evidence of Rühling and Tyler (1970) suggests.

In the present study, Cd content was found to be significantly higher in the "proximate" moss samples (0.79 ppm; <30 km from Thunder Bay) than in the "distant" samples (0.50 ppm; 50 - 137 km from Thunder Bay). This finding agrees with that of Rühling and Tyler (1973) who found that the relative decrease in Cd content of moss as one proceeded north in Scandinavia was second only to that for Pb.

Rühling and Tyler (1969) report that Pb and Cu content of mosses is significantly positively correlated with precipitation, but found no such relationship for Zn or Ni. Lazrus et al. (1970) have shown that a higher frequency of rainfall will tend to keep the atmosphere cleaner and thus increase metal deposition. While Groet (1976) was not able to correlate precipitation with metal content (due to a lack of accurate precipitation data), he did find a positive correlation between altitude (i.e. increased frequency of rainfall) and content of Cd and Zn. This suggests that wet deposition processes may have a more important role in determining content of these metals than for other metals. Since the Ignace area of northwestern Ontario receives slightly more yearly precipitation than does Thunder Bay (840 mm vs. 750 mm), this may in part be responsible for the relatively high Cd and Zn levels found there. It is interesting also to note that the Ni content of the Ignace moss shows the greatest relative decrease of all metals from that of

the sites nearer Thunder Bay (from 3.4 to 2.0 ppm) in spite of the fact that Ignace receives more precipitation. This observation is in line with the suggestion by both Rühling and Tyler (1969) and Groet (1976) that a larger share of Ni may be supplied through dry deposition processes.

Another consideration is that metals deposited at Ignace may in significant part originate from emissions at Winnipeg, Manitoba (pop. 570,000), 400 km to the west. Such emissions could be carried great distances at high altitudes by the prevailing westerly winds.

When regional background levels for northwestern Ontario are compared with literature values (Table 34) the results appear to be reasonable for all metals for which comparative data are available. Cadmium, Cu, ~~Hg~~^{Ni} and Pb concentrations in northwestern Ontario moss are all lower than in north-east United States moss (Groet, 1976), especially so for Ni (3.4 vs. 9.4 ppm) and Pb (30 vs. 131 ppm). Zn content is about the same. However, the moss used in the United States study is an acrocarpous species (*Leucobryum glaucum* (Hedw.) Schimp), thus making a direct comparison more difficult. Groet (1976) found that the Zn content of mosses from isolated regions of Quebec does not vary greatly from the average of 62 ppm in the north-east United States.

Concentrations encountered by Rühling and Tyler (1973) in samples of *H. splendens* from far northern Scandinavia are considerably lower for all metals (including Zn) than those

encountered in the present study, and generally much lower than those present in the northeastern U.S.A. This leads one to hypothesize that the metal contents of *P. schreberi* growing in far Northern Ontario may be significantly different ~~than~~ ^{from} the concentrations measured in this study.

IV) Comparison of Non-background Levels

The figures in Table 35 illustrate the extent to which bryophytes growing in polluted areas are able to accumulate heavy metals. Where an approximate range of values is given, the maximum was encountered adjacent to and/or downwind from the pollution source. In general, it is apparent that levels far exceeding those of background may be present.

D) Soil - Moss Relationships

I) Ratios of Soil Content to Moss Content

As stated in the Introduction, carpet-forming mosses usually obtain their nutrients in a passive manner from above. Thus, it might reasonably be expected that an enrichment of metals will occur as green moss tissue died and decomposed to form soil. Such an increase could be due to a continued uptake of metals via passive ion-exchange, perhaps contributed to by leaching from surface moss (Pakarinen and Tolonen, 1977), or to the release of metals on decomposition being proportionately less than the loss of organic matter (Tyler, 1972).

The large ratios of soil metal content to moss metal content for the organic soil sites (Table 12, p. 69) show that

Table 35

Metal content of moss (ppm, dry wt.) from polluted areas
of the present study compared with other results given
in the literature

S.D. = standard deviation

References:

- | | |
|----------------------------------|-----------------------------------|
| (1) Rinne (1975) | (7) Czarnowska (1974) |
| (2) results of present study | (8) Holden (1971) |
| (3) Tyler (1971) | (9) Le Blanc <u>et al.</u> (1974) |
| (4) Groet (1976) | (10) Hückabee (1973) |
| (5) Goodman and Roberts (1971) | (11) Yeaple (1972) |
| (6) Burkitt <u>et al.</u> (1972) | (12) Wallin (1976) |

Sample Size (n)	Thunder Bay Ontario (1) (mean ± S.D.)	Marathon ² Ontario (range)	Industrial ¹ Sweden (range)	Springfield ⁴ Massachusetts (mean)	Industrial ⁵ Wales (range)	Industrial ⁶ Britain (range)	Warsaw ⁷ Poland (range)	London ⁸ England	Murdochville ⁸ Quebec (range)
	12			17					
Metal: Cd	1.4 ± 0.6		2.5 - 50	0.93	3 - 9.5	50 - 150		12.3	0.5 - 4.4
Cu		14 - 21	50 - 2 500	14.0	20 - 70		14 - 35		41 - 1 340
Fe		1 600 - 3 800					900 - 1 850		
Mn		330 - 550					30 - 155		
Ni	5.7 ± 1.4	6 - 16		12.0					
Pb	150 ± 69	65 - 100		190	100 - 350	400 - 1 600	10 - 20	2 314	15 - 1 160
Zn	82 ± 19	90 - 225		72	150 - 345	1 000 - 7 000	100 - 250		46 - 282
Species Analyzed	<i>P. schreberi</i> , <i>H. splendens</i>	<i>P. schreberi</i>	<i>H. cupressiforme</i>	<i>L. glaucum</i>	<i>H. cupressiforme</i>	<i>Eurynchium cupressiforme</i>			<i>P. schreberi</i>
Sample Size (n)	5	9							
Metal: Hg	0.5 - 2	1.13	0.5 - 2	1 - 15					
	Marathon ² Ontario (range)	Appalachian ¹⁰ Valley (mean)	Urban New ¹¹ England (range)	Industrial ¹² Sweden (range)					

the concentrations for most metals are higher in the organic soils than in the overlying moss. This indicates that just such an enrichment does occur, especially for Cd, Hg, Pb and Zn. This is somewhat in opposition to the findings of Rühling and Tyler (1970) that the increase in content of the minor heavy metals (i.e. excluding Fe and Mn) in *H. splendens* was balanced by the dry matter decrease through decomposition. However, Pakarinen and Tolonen (1977) found that the Pb content of *S. fuscum* increased from the green moss to the underlying dead moss, and suggest that leaching from surface moss takes place.

In the present cases of Fe and Ni, the soil/moss ratios for the organic soils are considerably lower than those for the mineral soils. This indicates that the Fe and Ni content of mineral soils is generally higher than in either moss or in organic soils, and raises the possibility of contamination of the moss by the substrate. This could occur especially if the moss were in direct contact with mineral soils (seldom the case) and analyses were carried out on non-washed samples (as was done in the present study).

Although the Mn content of the soils is slightly higher than the moss, no trend is apparent. On average, the Cu contents of the soil and moss are about equal.

II) Correlations Between Soil and Moss Content

Pearson correlation coefficients between moss and soil metal content for the sample groups divided according to soil LOI are given in Table 13 (p. 72). When all sites are considered, significant positive correlations are present between the moss and soil content for Cd, Cu, Fe, Ni, Pb and Zn (i.e. all but Hg and Mn).

It would be expected that significant positive correlations would exist between the metal content of the moss and of the soil which it eventually aids in forming. The low correlation for Hg is difficult to account for, but may be explained in part by the very low levels of Hg present, related to its relatively recent unnatural introduction to the atmosphere due to the activities of man. The low correlation for Mn may be related to a competition for exchange sites occurring in the moss.

Only 3 correlations for the moss and mineral soil group are significant, those for Cu, Fe and Ni. The remainder are very low and usually negative. In view of the findings that Fe and Ni are present in higher amounts in mineral soils, the correlations for these metals are further evidence that the moss may be contaminated by mineral soils. Although the average amount of Cu in the soil is no higher than in the moss, the very high correlation for Cu is not surprising because the moss has a very high affinity for this metal. An occasional case was encountered where obvious contamination of the moss by the soil had occurred. This resulted in the Cu data for site Nos. 40 and 87 being rejected. Apparently, even in the remaining data, contam-

ination was responsible for higher than "normal" Cu contents being obtained.

The correlations for the organic soil sites are, overall, surprisingly low. Although they are all positive, the only significant correlations occur for Cu, Fe, Mn and Pb. The Fe and Mn results may be related to the findings of Rühling and Tyler (1970) that these were the only heavy metals whose content increased from young to old parts of *H. splendens*. These are also the metals whose organic chelates are least stable (Rühling and Tyler, 1973) and which are bound and retained by the moss to the least extent (Rühling and Tyler, 1970). Perhaps quantities of Fe and Mn are more easily released by the moss and pass into the organic soil layer beneath.

When the correlations for all 3 groups are viewed simultaneously, trends are apparent for Cu and Ni (correlation decreases as soil organic content increases) and for Hg, Mn, Pb and perhaps Zn (correlation increases as soil organic content increases).

III) Variation in Relationship with Different Degrees of Pollution

The relationship between the metal content of the soil and moss in areas subjected to different degrees of pollution can be appreciated by referring to the histograms in Figure 9 (p. 74). Regional variations among the moss samples themselves, and among the soil samples, are also apparent.

Region 1 samples are those in sample Group VI, located at Marathon. This area is a special case, because samples were deliberately obtained close to a suspected pollution source, the American Can Company paper mill. The metal concentrations for this area (Table 15, p. 84) are indeed considerably higher, for the most part, than in the other areas sampled. Mercury content, in particular, is high. The company has recently been fined heavily by the courts for discharging Hg into Lake Superior in higher than allowable amounts. Evidently, a considerable amount of this pollutant has also been released into the atmosphere.

Region 2 samples are the "proximate" group of samples (Table 21, p. 98), situated <30 km from Thunder Bay. This region is thought to be subjected to a considerable amount of pollution from the city.

Samples in Region 3 are the "distant" group, situated from 50 - 137 km from the city. This area receives a smaller amount of pollution from Thunder Bay.

Finally, Region 4 samples are located at Ignace (and thus are composed of Group I samples). Metal concentrations encountered here must be considered to be representative of essentially unpolluted situations.

On examining the histograms, it is clear that in highly polluted Region 1 (Marathon), the ratio of soil metal content to moss metal content is the highest of all regions for all metals except Ni. This ratio generally decreases as the degree of pollution increases, and in fact becomes <1 (i.e. soil content <

moss content) for Cd, Cu, Pb and Zn in the Ignace region. Trends for Hg, Mn and Ni are less apparent, while the Fe ratio remains fairly constant. As has been determined by regression analysis, Cd, Cu, Pb and Zn are the only metals that are emitted in apparently significant overall amounts by sources within the city of Thunder Bay, perhaps accounting for the similarity and regularity in soil/moss ratio trends for these 4 metals.

Therefore, the degree and type of relationship between the content of a particular metal in soil and moss seems to depend on a complex combination of factors including: the ability of the moss and soil ~~and~~^{to} retain the metal ion; the degree to which the metal content is attributable to wet (most metals, perhaps especially Cd and Zn) or dry (Ni) deposition; the manner in which the metal content changes during decomposition; the nature and metal content of the substrate; the degree of site contamination; and the amount of cover present.

IV) General Comparison of Soil and Moss

In the previous discussion of correlations and regional background levels, the following points have become apparent:

1) Large variations in possible background levels in soils contrast sharply with the relatively uniform metal content of bryophytes.

2) The large variations in soils are due primarily to the strong relationships between soil metal content and soil pH and LOI. These relationships are comparatively weak for the moss.

3) Correlations between the various pairs of metals in the soil are generally not as high as they are in the moss.

4) The positive relationship between cover and metal content is much less apparent for the soil than for the moss.

5) The negative relationship between distance from Thunder Bay and metal content is also much less apparent for the soil than for the moss.

The general conclusion is that soils are not as good indicators of metal deposition as are mosses, particularly in relatively uncontaminated regions.

E) Distribution Patterns and Possible Sources of Metals

I) Comparison of Levels in Sample Groups

A comparison of the general levels of metals in moss from sample Groups I - V is presented below, in order of apparent degree of pollution from lowest to highest. (Sample Group VI (Marathon) is excluded because it is a special, highly polluted case.) The actual levels of metals in both soil and moss are given in Table 15 (p. 84).

a) Group I

The Ignace mosses contain the lowest amounts of all heavy metals except Cd (lower in Groups II, IV and V), Mn (lower in Groups II and V) and Zn (also lower in Groups II and V). The relatively high Cd and Zn concentrations at Ignace have already been related (in the discussion of possible background

levels) to the greater precipitation of the area and to the lack of competition due to lower levels of the other metals. The Mn results may also be related to one or both of these factors.

b) Groups II, V

The mosses collected north and west of the city have similar metal concentrations that are the lowest of the Thunder Bay area groups. These results are expected, because both areas are comparatively undisturbed, and winds from the south and south-east are rare. Winds from the east are fairly common (Figure 5, p. 16), but may not carry much contaminant because the city is narrow in an east-west direction. The rather high Fe content of the Group II mosses may be due to contamination from the soil.

c) Group IV

The area with the next lowest content of most metals is apparently that lying east of the city. One would expect to find quite high levels here due to the westerly direction of the prevailing winds. However, analysis of the data from the area is difficult because some sites are located at low elevations near the north shore of Lake Superior cottage area, while others are scattered along the length of the Sibley Peninsula. Mean cover is also relatively low. It is possible that emissions from secondary industry in certain north shore communities (i.e. the paper mill at Red Rock) may be influencing the eastern portion

of the sample area. This would at least partially explain the apparent slight increase in moss content for most metals (especially Hg and Zn), revealed by correlation and regression analyses, that occurs as one proceeds from Thunder Bay to Dorion (Sibley Peninsula samples excluded). It may also be that a more thorough testing of the area would produce different results.

Mean data for the 9 Sibley Peninsula samples alone are given in Table 16^(p. 86). A general observation is that although the peninsula lies directly downwind of the city, the metal contents are no greater than might be found at an equal distance west or north of Thunder Bay. This may be due to the relatively high elevation of the sample sites (300 m) with respect to the city (200 m) and/or to their relatively low cover. It is also possible that the effect of emissions from Thunder Bay is not very great because the city extends in a north-east, south-west direction and is relatively narrow across the middle.

d) Group III

The mosses from the area south-west of Thunder Bay contain the highest amounts of all metals except Mn and Pb (which are apparently higher east of the city, only). This indicates that the area is subjected to considerable pollution, probably due in part to its relatively high population density and history of human activity. In addition, there are a disproportionately large number of industries located in the south-west part of the city whose operations are suspected of contributing to the high levels in the area. These include the

Canada Car equipment manufacturing plant, the thermal generating station on Mission Island, the Valley Camp base metal-handling facilities on the Kam River, the iron ore loading dock on the water-front, the Great Lakes Paper Company kraft mill, the Dow Chemical chlor-alkali plant (until 1973), and the Thunder Bay International Airport. It is also possible that emissions from practically anywhere in the city can be deposited here by a wind from the north-east (a not uncommon occurrence).

II) Discussion of Individual Metals

a) Cadmium

The distribution pattern for Cd, constructed from the best fit group regression equations, is shown in Figure 14 (p.113). When the best fit overall relationship (logarithmic) is used to illustrate the pattern (Figure 15, p. 118), the picture is somewhat distorted, especially for the area south-west of Thunder Bay.

The relatively high levels of Cd south-west of the city were previously encountered in soils by P. Barclay-Estrup (personal communication). It is conjectured that Cd used in electroplating processes at the Canada Car plant, emissions from burned aviation fuel, and emissions from the thermal generating station, are responsible for the elevated levels in the area.

Other sources of Cd are fuel combustion by industry and in homes, fuel combustion by motor vehicles, and tire wear (Environment Canada, 1976b).

b) Copper

The indication from Figure 16 (p. 120) is that Cu content decreases in a gradual linear fashion from Thunder Bay, and that since Ignace content is less than that represented by the outer curve, background levels are not even reached at a distance of 75 km from the city. However, even the overall relationship with distance is only significant at the 5% level, and there is considerable variation among the mean and predicted contents of the various sample groups. Therefore, the situation as depicted in Figure 16 represents little more than a possibility.

There are no major sources of Cu emission in the Thunder Bay area. Possible sources of a minor nature are the Valley Camp base metal-handling facilities in south-west Thunder Bay, as well as disposal and incineration of Cu-containing substances.

c) Iron

As shown in Table 21 (p. 98), there is a significant difference between the mean "proximate" and "distant" Fe content of *P. schreberi*, which indicates that the city contains emission sites of this metal. The fact that the regression equations in Table 24 (p. 123) are not significant is probably due to the large amount of natural variation in Fe content when the effect of cover is accounted for.

Although there are apparently no major industrial sources of atmospheric Fe in Thunder Bay, possible sources of a more minor nature include the iron ore loading dock, rusting automobiles and machinery, and refuse incineration.

d) Mercury

Table 21 (p. 98) shows that there is no significant difference between the Hg content of proximate and distant moss samples (although mean proximate content is apparently slightly greater). The question then arises as to why the mean Hg content of the Ignace moss is significantly lower than the content of local mosses (Table 15, p. 84). Although mean cover at Ignace is slightly lower, it is not probable that this alone is responsible for the difference.

A likely source of atmospheric Hg in the past was the Dow Chemical chlor-alkali plant which operated until 1973 in the south-west extremity of the city (see Wallin, 1976). There is considerable use of Hg in electrical apparatus such as batteries, some of which is released into the air when these are disposed of. Another source of recent concern is the burning of fossil fuels by thermal-electric stations, such as the coal-fired plant located in Thunder Bay on Mission Island.

e) Manganese

The results have shown that Mn adsorption is probably limited to a large extent by competition with other metals for adsorption sites on the moss. This would explain why Mn content appears to increase with increasing distance from the city (Table 26, p. 127).

Possible sources of atmospheric Mn in the Thunder Bay area are: fuel combustion by industry and power plants, solid waste incineration and pesticide application (Environment Canada,

1976a).

f) Nickel

A significant overall distance relationship is not present for Ni when the effect of cover is accounted for (Table 27, p. 130) although other results had indicated that Ni content does decrease somewhat with increasing distance from the city (Table 21, p. ~~130~~⁹⁸). There is a significant distance relationship, however, in the area south-west of the city.

Apparently, there are no major sources of atmospheric Ni in Thunder Bay. Possible minor sources include the Valley Camp base metal-handling facilities, and incineration of Ni-plated or Ni-containing substances such as "nicad" batteries.

g) Lead

The best fit equations representing the distribution of Pb in Thunder Bay area mosses (Table 28, p. 132) are distinctly similar to those for Cd. The concentration gradient constructed from the group equations (Figure 17, p. 134) does not, however, show a significantly higher Pb content south-west of the city. The gradient constructed from the best fit equation (logarithmic) for the overall data (Figure 18, p. 137) is very similar, and hence the overall equation may be used for prediction purposes.

A major source of atmospheric Pb in urban areas is the combustion of leaded gasolines. Since unleaded gasolines are required for use in most late-model automobiles, the present-day Pb content of the atmosphere (and hence of *P. schreberi*) may

represent a maximum. Other sources are the disposal or incineration of Pb-containing substances such as paints and storage batteries.

h) Zinc

The overall best fit distance relationship for Zn is semi-logarithmic (Table 29, p. 139). The distribution pattern is shown in Figure 19 (p. 141). The small gradient reveals that the decrease with distance is very slight. This is in line with the observation by Groet (1976) that the Zn content of bryophytes does not vary greatly according to locale. The fact that the mean Ignace content is slightly higher than apparent background around Thunder Bay may be due to a relative ease with which Zn may be displaced by other metals, the higher precipitation at Ignace, and/or emissions from Winnipeg being deposited on the Ignace area.

F) General Discussion and Conclusions

As stated in the Introduction, the main purpose of this study was to determine levels of heavy metals in moss and soils in northwestern Ontario. It is felt that this purpose has indeed been fulfilled. Levels have been determined for areas near Thunder Bay which are probably contaminated by emissions from the city. Regional background levels have also been revealed, for the region 50 - 75 km from Thunder Bay and for the Ignace area, 200 km away.

The secondary aims of this study have been achieved, as well. It has been shown that levels of Cd, Cu, Pb and Zn in Thunder Bay area moss decrease significantly with increasing distance from the city. The nature of this decrease which best fits the data is logarithmic for both Cd and Pb, semi-logarithmic for Zn and linear for Cu.

A significant effect of canopy cover in increasing the concentrations of most metals in the moss, especially in polluted areas, was uncovered. In any subsequent study, care should be exercised to ensure that the effect of cover is correctly taken into account.

The comparison of moss and soil levels of heavy metals has revealed an interesting relationship. In relatively highly polluted areas, the soil content for most metals is considerably higher than the moss content. However, as the degree of contamination decreases, this discrepancy narrows. In the relatively unpolluted Ignace region, the moss content for

several metals exceeds the soil content.

In general, it is felt that the information presented here-in should serve as a solid base for continued investigation. In particular, present-day metal concentrations may be compared with those of future studies in order to gauge the impact of further industrial and urban development.

Appendix 1

Site data

-see Figures 3 (p. 11) and 5 (p. 16) for general site locations

D = approximate distance from urban limits of
Thunder Bay (km)

C = canopy cover: 1 = 0 - 20 %
2 = 20 - 40 %
3 = 40 - 60 %
4 = 60 - 80 %
5 = 80 -100 %

Site No.	Location	D	C	Associated Trees and Shrubs
	1.6 km up Hwy. 599, 70 m E. of road		2	<i>P. tremuloides</i> , <i>Alnus rugosa</i> (Du Roi) Spreng. <i>Vaccinium myrtilloides</i> Michx., <i>Diervilla lonicera</i> Mill.
2	3.2 km up, 150 m E.		2	<i>P. banksiana</i> , <i>A. rugosa</i> , <i>P. mariana</i> , <i>V. myrtilloides</i> , <i>P. tremuloides</i>
3	4.8 km up, 110 m E.			<i>A. balsamea</i> , <i>P. glauca</i> , <i>B. papyrifera</i>
	6.4 km up, 50 m W.			<i>P. banksiana</i> , <i>P. strobus</i> , <i>B. papyrifera</i> , <i>Chamaedaphne calyculata</i> (L.) Moench, <i>V. myrtilloides</i>
5	8.0 km up, 320 m E.	200		<i>P. balsamifera</i> , <i>P. strobus</i> , <i>B. papyrifera</i> , <i>A. rugosa</i> , <i>Ledum groenlandicum</i> L.
6	9.6 km up, 175 m W.			<i>P. tremuloides</i> , <i>Sorbus</i> sp.
	11.2 km up, 350 m E.			<i>P. glauca</i> , <i>A. balsamea</i> , <i>L. groenlandicum</i> , <i>V. myrtilloides</i>
8	12.8 km up, 500 m W.			<i>P. glauca</i> , <i>B. papyrifera</i> , <i>V. myrtilloides</i>
9	14.6 km up, 380 m W.			<i>P. glauca</i> , <i>A. balsamea</i> , <i>Acer spicatum</i> Lamb, <i>Alnus</i> sp.
10	16.6 km up, 50 m E.		3	<i>A. spicatum</i> , <i>A. balsamea</i> , <i>P. glauca</i> , <i>Alnus</i> sp., <i>B. papyrifera</i>
11	17.9 km up, 160 m W.		2	<i>A. rugosa</i> , <i>A. balsamea</i> , <i>P. mariana</i> , <i>Vaccinium angustifolium</i> Ait., <i>V. myrtilloides</i>

Site No.	Location	D	C	Associated Trees and Shrubs
12	19.2 km up Hwy. 599, 320 m W. of road		2	<i>L. groenlandicum</i> , <i>V. angustifolium</i> , <i>P. glauca</i>
13	20.8 km up, 450 m W.			<i>Prunus virginiana</i> L., <i>V. myrtilloides</i> , <i>L. groenlandicum</i> , <i>P. mariana</i>
14	22.4 km up, 200 m E.			<i>V. myrtilloides</i> , <i>P. mariana</i> , <i>L. groenlandicum</i> , <i>B. papyrifera</i> , <i>Salix discolor</i> Muhl.
15	24.0 km up, 150 m W.		1	<i>P. glauca</i> , <i>P. mariana</i> , <i>V. angustifolium</i> , <i>L. groenlandicum</i>
16	25.6 km up, 225 m ?	200		<i>P. papyrifera</i> , <i>P. mariana</i> , <i>A. balsamea</i> , <i>V. myrtilloides</i> , <i>L. groenlandicum</i>
17	27.2 km up, 1100 m E.			<i>B. papyrifera</i> , <i>A. balsamea</i> , <i>P. glauca</i> , <i>A. spicatum</i>
18	28.8 km up, 195 m W.		1	<i>B. papyrifera</i> , <i>A. balsamea</i> , <i>L. groenlandicum</i> , <i>Rubus strigosus</i> Michx.
19	30.4 km up, 450 m W.		4	<i>L. groenlandicum</i> , <i>A. spicatum</i> , <i>A. balsamea</i> , <i>P. mariana</i> , <i>P. banksiana</i>
20	32.0 km up, 220 m W.		5	<i>A. balsamea</i> , <i>B. papyrifera</i>
21	33.6 km up, 230 m W.		4	<i>P. glauca</i> , <i>Alnus crispa</i> (Ait.) Pursh, <i>P. tremuloides</i> , <i>P. mariana</i> , <i>D. lonicera</i>
22	35.2 km up, 120 m W.		3	<i>L. groenlandicum</i> , <i>V. myrtilloides</i> , <i>V. angustifolium</i> , <i>A. balsamea</i> , <i>A. rugosa</i> , <i>P. mariana</i>

Site No.	Location	D	C	Associated Trees and Shrubs
23	36.8 km up Hwy. 599, 1750 m W. of road		1	<i>P. balsamifera</i> , <i>R. strigosus</i> , <i>V. myrtilloides</i> , <i>A. balsamea</i> , <i>P. glauca</i>
24	38.4 km up, 375 m W.		200	<i>A. balsamea</i> , <i>R. strigosus</i> , <i>Ribes glandulosum</i> Grauer
25	40.0 km up, 300 m E.		2	<i>P. glauca</i> , <i>P. mariana</i> , <i>A. bal-</i> <i>samea</i> , <i>B. papyrifera</i> , <i>D. lonicera</i>
26	3.4 km up Hwy. 527, 588, 160 m E. of road	5	3	<i>P. glauca</i> , <i>B. papyrifera</i> , <i>Lon-</i> <i>icera canadensis</i> Bartr., <i>Ribes</i> <i>hirtellum</i> Michx., <i>Salix</i> sp.
27	6.1 km up, 17.5 m E.	8	2	<i>A. rugosa</i> , <i>D. lonicera</i> , <i>Prunus</i> <i>pensylvanica</i> L., <i>P. balsamifera</i> , <i>R. strigosus</i>
28	9.4 km up, 65 m W.	10	5	<i>A. balsamea</i> , <i>B. papyrifera</i> , <i>V.</i> <i>myrtilloides</i> , <i>Sambucus pubens</i> Michx., <i>D. lonicera</i> , <i>L. cana-</i> <i>densis</i>
29	12.8 km up, 360 m W.	14	3	<i>P. tremuloides</i> , <i>B. papyrifera</i> , <i>A. balsamea</i> , <i>D. lonicera</i> , <i>P.</i> <i>mariana</i> , <i>V. angustifolium</i>
30	16.3 km up, 150 m W.	20	3	<i>A. balsamea</i> , <i>Sorbus americana</i> Marsh., <i>Amelanchier sanguinea</i> (Pursh) DC., <i>P. glauca</i> , <i>V. angus-</i> <i>tifolium</i> , <i>V. myrtilloides</i>
31	19.2 km up, 225 m W.	20	3	<i>P. tremuloides</i> , <i>A. balsamea</i> , <i>S.</i> <i>discolor</i> , <i>P. mariana</i> , <i>B. papyri-</i> <i>fera</i> , <i>V. myrtilloides</i>
32	22.6 km up, 210 m W.	22	2	<i>A. balsamea</i> , <i>S. americana</i> , <i>R.</i> <i>glandulosum</i> , <i>R. strigosus</i> , <i>L.</i> <i>groenlandicum</i> , <i>B. papyrifera</i> , <i>P. mariana</i>

Site No.	Location	D	C	Associated Trees and Shrubs
33	25.1 km up Hwy. 527, 24 60 m W. of road		1	<i>P. mariana</i> , <i>V. myrtilloides</i> , <i>L. groenlandicum</i>
34	28.2 km up, 425 m W.	27	4	<i>P. tremuloides</i> , <i>B. papyrifera</i> , <i>A. balsamea</i> , <i>D. lonicera</i> , <i>A. crispa</i> , <i>V. myrtilloides</i>
35	34.1 km up, 450 m E.	33	4	<i>P. mariana</i> , <i>P. tremuloides</i> , <i>D. lonicera</i> , <i>V. myrtilloides</i> , <i>Viburnum edule</i> (Michx.) Raf.
36	38.2 km up, 130 m E.	37	5	<i>B. papyrifera</i>
37	41.8 km up, 70 m W.	38	4	<i>A. rugosa</i> , <i>B. papyrifera</i> , <i>A. balsamea</i> , <i>Thuja occidentalis</i> L., <i>V. myrtilloides</i> , <i>Rosa acicularis</i> Lindl.
38	45.3 km up, 300 m E.	41	2	<i>P. mariana</i> , <i>A. balsamea</i> , <i>B. papyrifera</i>
39	47.7 km up, 1600 m E.	44	2	<i>B. papyrifera</i> , <i>A. balsamea</i> , <i>P. tremuloides</i>
40	50.6 km up, 50 m W.	43	4	<i>A. crispa</i> , <i>S. discolor</i> , <i>A. rugosa</i> , <i>A. balsamea</i>
41	54.4 km up, ?	46		<i>P. mariana</i> , <i>V. myrtilloides</i> , <i>V. angustifolium</i> , <i>L. groenlandicum</i>
42	57.6 km up, 170 m E.	48		<i>A. balsamea</i> , <i>B. papyrifera</i> , <i>R. glandulosum</i> , <i>R. strigosus</i> , <i>L. groenlandicum</i>
43	61.3 km up, 110 m E.	51	3	<i>B. papyrifera</i> , <i>A. balsamea</i> , <i>A. crispa</i> , <i>R. strigosus</i>

Site No.	Location	D	C	Associated Trees and Shrubs
44	64.5 km up Hwy. 527, 200 m W. of road	53		<i>B. papyrifera</i> , <i>A. balsamea</i> , <i>P. tremuloides</i> , <i>A. spicatum</i> , <i>P. mariana</i> , <i>R. strigosus</i>
45	67.0 km up 70 m W.	57		<i>B. papyrifera</i> , <i>A. balsamea</i> , <i>A. spicatum</i> , <i>V. myrtilloides</i> , <i>V. angustifolium</i> , <i>L. groenlandicum</i>
46	69.9 km up, 50 m W.	59		<i>B. papyrifera</i> , <i>A. balsamea</i> , <i>R. acicularis</i> , <i>Sorbus decora</i> (Sarg.) Schn.
47	73.6 km up, 130 m E.	61	3	<i>B. papyrifera</i> , <i>A. balsamea</i> , <i>A. crispa</i> , <i>P. glauca</i> , <i>P. tremuloides</i>
48	76.8 km up, 275 m W.	63	2	<i>B. papyrifera</i> , <i>A. balsamea</i> , <i>P. mariana</i>
49	80.2 km up, 425 m E.	65	2	<i>B. papyrifera</i> , <i>S. americana</i> , <i>A. balsamea</i>
50	near Candy Mt., 150 m S. of Paipoonge Conc. II	12	5	<i>A. balsamea</i> , <i>B. papyrifera</i> , <i>P. balsamifera</i> , <i>P. tremuloides</i> , <i>V. angustifolium</i> , <i>Cornus stolonifera</i> Michx.
51	W. extremity of Paipoonge Conc. II, 95 m S. of dirt road	19		<i>A. balsamea</i> , <i>B. papyrifera</i> , <i>A. spicatum</i> , <i>P. balsamifera</i> , <i>Lonicera villosa</i> (Michx.) R. & S.
52	turn in road before Oliver L., 325 m down trail	22	4	<i>A. balsamea</i> , <i>B. papyrifera</i> , <i>P. tremuloides</i> , <i>A. spicatum</i>
53	Mayotte's cottages, 300 m W. from angle of roads	24	4	<i>B. papyrifera</i> , <i>A. balsamea</i> , <i>A. spicatum</i> , <i>D. lonicera</i> , <i>R. acicularis</i> , <i>V. myrtilloides</i>

Site No.	Location	D	C	Associated Trees and Shrubs
54	Gillies Twp, 450 m from Hwy. 588 toward Rabbit Mt.	27	5	<i>A. balsamea</i> , <i>P. tremuloides</i> , <i>B. papyrifera</i> , <i>R. strigosus</i> , <i>D. lonicera</i> , <i>A. spicatum</i>
55	1.5 km from Hwy. 595 towards Wamsley, 20 m S. of trail	32	4	<i>A. balsamea</i> , <i>B. papyrifera</i> , <i>P. tremuloides</i> , <i>A. spicatum</i> , <i>D. lonicera</i> , <i>Rubus parviflorus</i> Nutt.
56	0.8 km S. of Wamsley, 35 m into bush	30	1	<i>A. balsamea</i> , <i>A. rugosa</i> , <i>R. strigosus</i> , <i>Betula pumila</i> L., <i>S. pubens</i>
57	7.2 km N.W. of above, 0.8 km S. of Hwy. 595, 90 m W. of private road	39	5	<i>P. balsamifera</i> , <i>P. tremuloides</i> , <i>A. balsamea</i> , <i>B. papyrifera</i> , <i>D. lonicera</i> , <i>R. acicularis</i>
58	2.4 km down trail S. off south- ernmost part of Hwy. 595	36	1	<i>P. banksiana</i> , <i>P. glauca</i> , <i>A. balsamea</i> , <i>B. papyrifera</i> , <i>R. acicularis</i> , <i>V. myrtilloides</i>
59	near Canada Cus- toms, 70 m E. of Hwy. 61	45	4	<i>A. balsamea</i> , <i>B. papyrifera</i> , <i>Sorbus sp.</i> , <i>R. glandulosum</i>
60	12.0 km W along Devon Rd., 25 m S.	48	4	<i>A. balsamea</i> , <i>Acer negundo</i> L., <i>A. rugosa</i>
61	Devon Rd. at Ar- row R. turn, 40 m W.	51	3	<i>A. balsamea</i> , <i>D. lonicera</i>
62	3.2 km N. of above, 75 m W. of road	51	3	<i>P. mariana</i> , <i>S. decora</i> , <i>A. balsamea</i> , <i>L. canadensis</i>
63	3.2 km N. of above, 320 m E.	48	1	<i>A. balsamea</i> , <i>P. tremuloides</i> , <i>C. stolonifera</i> , <i>Shepherdia canadensis</i> (L.) Nutt.

Site No.	Location	D	C	Associated Trees and Shrubs
64	3.5 km N. of 63, 7.5 m W. of road	49	4	<i>A. balsamea</i> , <i>B. papyrifera</i> , <i>A. rugosa</i> , <i>R. acicularis</i>
65	12.8 km N. of turn at Arrow R., 90 m E.	47	4	sample collected from several fallen trees in <i>A. balsamea</i> stand
66	16.3 km N. of Arrow R. turn, 1.6 km from junc. with Hwy. 588, 400 m E. of road	45	3	<i>A. balsamea</i> , <i>A. rugosa</i> , <i>P. tremuloides</i> , <i>C. stolonifera</i> , <i>R. parviflorus</i>
67	150 m S. of Expressway, 250 m N. of Lakeshore Dr.	8		<i>A. balsamea</i> , <i>B. papyrifera</i> , <i>S. decora</i> , <i>A. spicatum</i> , <i>D. lonicera</i> , <i>A. sanguinea</i>
68	junc. Expressway and Lakeshore Dr., 250 m N.	28		<i>P. glauca</i> , <i>B. papyrifera</i> , <i>S. discolor</i> , <i>A. balsamea</i> , <i>P. tremuloides</i> , <i>V. myrtilloides</i>
69	17.1 km W. of Pearl, 1.6 km down Birch Beach Rd.	28		<i>B. papyrifera</i> , <i>A. balsamea</i> , <i>R. acicularis</i> , <i>D. lonicera</i>
70	8.5 km W. of Pearl, 450 m S. of Hwy. 11/17	38		<i>B. papyrifera</i> , <i>A. balsamea</i>
71	just W. of Pearl, 450 m N.	43	2	<i>P. balsamifera</i> , <i>A. balsamea</i> , <i>B. papyrifera</i> , <i>P. glauca</i> , <i>L. canadensis</i> , <i>C. stolonifera</i>
72	8.3 km. W. of Dorion, 1.0 km S.	53	3	<i>P. balsamifera</i> , <i>S. discolor</i> , <i>B. papyrifera</i> , <i>P. glauca</i> , <i>L. canadensis</i> , <i>C. stolonifera</i>

Site No.	Location	D	C	Associated Trees and Shrubs
73	Dorion, 2.4 km S. of Hwy. 11/17	58	3	<i>S. decora</i> , <i>A. balsamea</i> , <i>B. papyrifera</i> , <i>A. rugosa</i> , <i>R. strigosus</i> , <i>L. groenlandicum</i>
74	Sibley Penin., 8.0 km N. of lookout turnoff, 20 m W.	31	1	<i>P. glauca</i> , <i>A. crispa</i> , <i>B. papyrifera</i> , <i>D. lonicera</i> , <i>V. myrtilloides</i>
75	1.6 km N. of lookout turnoff, 35 m W.	28	4	<i>P. mariana</i> , <i>A. balsamea</i> , <i>P. glauca</i> , <i>B. papyrifera</i> , <i>A. crispa</i> , <i>D. lonicera</i>
76	N.W. part of island in Poundsford L.	29	3	<i>B. papyrifera</i> , <i>A. balsamea</i> , <i>T. occidentalis</i> , <i>P. glauca</i>
77	at lookout, 75 m E. of road	26	1	<i>P. glauca</i> , <i>P. tremuloides</i> , <i>V. angustifolium</i>
78	475 m W. of Pickereel L. along nature trail	30	1	<i>P. strobus</i> , <i>A. balsamea</i> , <i>B. papyrifera</i> , <i>T. occidentalis</i> , <i>Salix</i> sp.
79	W. shore of Lake Mary Louise, 200 m W. of road	29	2	<i>P. balsamifera</i> , <i>T. occidentalis</i> , <i>B. papyrifera</i> , <i>P. tremuloides</i> , <i>P. glauca</i>
80	S. shore of Lake Mary Louise, 325 m S. of road	29	1	<i>B. papyrifera</i> , <i>P. balsamifera</i> , <i>P. glauca</i> , <i>P. mariana</i>
81	3.2 km N. of Silver Islet, 120 m E. of Hwy. 587	31	1	<i>P. tremuloides</i> , <i>P. mariana</i> , <i>A. balsamea</i> , <i>C. stolonifera</i> , <i>R. acicularis</i>
82	just E. of Silver Islet, 20 m E. of trail	31	1	<i>B. papyrifera</i> , <i>A. balsamea</i>

Site No.	Location	D	C	Associated Trees and Shrubs
83	2.2 km down Hazelwood Dr. From Hwy. 102, 400 m N.	4	3	<i>A. balsamea</i> , <i>B. papyrifera</i> , <i>P. tremuloides</i> , <i>P. balsamifera</i> , <i>A. spicatum</i> , <i>C. stolonifera</i>
84	Hwy. 102 just W. of Mapleward Rd., 700 m S.	12	4	<i>A. balsamea</i> , <i>A. rugosa</i> , <i>P. tremuloides</i> , <i>S. decora</i> , <i>D. lonicera</i>
85	350 m E. of Hwy. 102, 230 m N. of Auto Rd.	17	3	<i>A. spicatum</i> , <i>B. papyrifera</i> , <i>A. balsamea</i> , <i>P. tremuloides</i> , <i>L. canadensis</i>
86	2.1 km E. of junction Hwy. 102 and 11/17, 750 m S.	36	3	<i>A. balsamea</i> , <i>B. papyrifera</i> , <i>P. tremuloides</i> , <i>A. rugosa</i> , <i>D. lonicera</i>
87	8.3 km N.W. of junction, 220 m W. of Hwy. 11/17			<i>P. glauca</i> , <i>A. crispa</i> , <i>B. papyrifera</i> , <i>P. tremuloides</i>
88	18.9 km N.W. of junction, 290 m W.	45		<i>V. myrtilloides</i> , <i>A. spicatum</i> , <i>Rosa blanda</i> Ait.
89	Hwy. 11, 6.4 km W. of junction with 11/17, 290 m N.	56	3	<i>A. balsamea</i> , <i>P. tremuloides</i> , <i>B. papyrifera</i> , <i>A. spicatum</i> , <i>D. lonicera</i>
90	just W. of Swamp R., 8.8 km W. of above, 1200 m N. of Hwy. 11	65	4	<i>A. balsamea</i> , <i>B. papyrifera</i> , <i>P. tremuloides</i> , <i>D. lonicera</i> , <i>V. myrtilloides</i>
91	9.3 km W. of Swamp R., 900 m N. of Hwy. 11, 30 m W. of trail	73		<i>P. mariana</i> , <i>L. groenlandicum</i> , <i>V. myrtilloides</i>
92	9.4 km W. of 91, 300 m S. of Hwy. 11	80	2	<i>B. papyrifera</i> , <i>A. balsamea</i> , <i>P. tremuloides</i> , <i>D. lonicera</i>

Site No.	Location	D	C	Associated Trees and Shrubs
93	100 m E. of Birch Pt. Rd., 375 m N. of Hwy. 11	90	5	<i>B. papyrifera</i> , <i>A. spicatum</i> , <i>P. tremuloides</i> , <i>D. ionicera</i> , <i>A. crispa</i> , <i>A. rugosa</i>
94	10.9 km W. of above, 350 m S. of Hwy. 11 across small lake	100	3	<i>B. papyrifera</i> , <i>A. balsamea</i> , <i>A. crispa</i> , <i>P. mariana</i> , <i>R. strigosus</i>
95	10.9 km W. of above, 500 m S. of Hwy. 11, 50 m E. of microwave tower road	110	1	none
96	6.4 km W. of above, 210 m N. of Hwy. 11	117	2	<i>P. banksiana</i> , <i>B. papyrifera</i> , <i>P. mariana</i> , <i>P. tremuloides</i> , <i>L. canadensis</i> , <i>V. myrtilloides</i>
97	10.2 km W. of above, 650 m N. of Hwy. 11, 15 m W. of logging road	126	1	<i>B. papyrifera</i> , <i>V. myrtilloides</i>
98	75 m W. of Mathieu Lumber Co. Rd., 1300 m W. of Hwy. 11	137	3	<i>P. mariana</i> , <i>B. papyrifera</i> , <i>A. balsamea</i> , <i>A. spicatum</i> , <i>D. ionicera</i>
99	450 m E. of Howcum L. Rd. down logging road	21	1	<i>A. balsamea</i> , <i>P. tremuloides</i> , <i>B. papyrifera</i> , <i>V. myrtilloides</i> , <i>L. groenlandicum</i> , <i>L. laricina</i>
100	island in Marks Lake, Marks Twp.	73	1	n.d.
101	Town of Marathon, near Shell station on small hill	200	n.d.	n.d.
102	on hill just S.E. of paper mill	200	n.d.	n.d.

Site No.	Location	D	C	Associated Trees and Shrubs
103	on mossy rock slope facing bay, just S.W. of paper mill	200	n.d.	n.d.
104	1.2 km toward Marathon from Hwy. 17, 0.4 km N. of road near lake	200	n.d.	n.d.
105	1.6 km E. of Hwy. 17, down continuation of Marathon Road	200	n.d.	n.d.

Literature Cited

- Ahti, J. (1964). Macrolichens and their zonal distribution in boreal and arctic Ontario, Canada. *Annales Botanica Fennica* 1: 1-35 (Reprint).
- Atkinson, H. J., G. R. Giles, A. J. Maclean and J. R. Wright, eds. (1958). Chemical Methods of Soil Analysis. Contribution No. 769 (Revised). Canada Department of Agriculture, Ottawa.
- Balsillie, D., P. C. McGovern and W. D. McIlveen (1975). Environmental Studies in the Timmins Area. Ontario Ministry of the Environment, Sudbury.
- Blokker, P. C. (1972). A literature survey of some health aspects of lead emissions from gasoline engines. *Atmospheric Environment* 6: 1-18.
- Bowen, H. J. M. (1966). Trace Elements in Biochemistry. Academic Press, New York.
- Brooks, R. R. (1972). Geobotany and Biogeochemistry in Mineral Exploration. Harper and Row, New York.
- Burkitt, A., P. Lester and G. Nickless (1972). Distribution of heavy metals in the vicinity of an industrial complex. *Nature* 238: 166-167.
- Campbell, J. A. (1976). A mathematical treatment of the variation of heavy metal content of lichens with distance from a source. *Lichenologist* 8: 83-86.

- Cannon, H. L. and J. M. Bowles (1962). Contamination of vegetation by tetraethyl lead. *Science* 138: 765-766.
- Chow, T. J. (1970). Lead accumulation in roadside soil and grass. *Nature* 225: 295-296.
- Coombes, A. J. and N. W. Lepp (1974). The effect of Cu and Zn on the growth of *Marchantia polymorpha* and *Funaria hygrometrica*. *The Bryologist* 77: 447-452.
- Crum, H. (1973). Mosses of the Great Lakes Forest. Contributions from the University of Michigan Herbarium, Ann Arbor, 10: 1-404.
- Czarnowska, K. (1974). The accumulation of heavy metals in soils and plants in Warsaw area (exemplified by grasses and mosses). *Polish Journal of Soil Science* VII: 117-122.
- Damman, A. W. H. (1971). Effect of vegetation on site fertility. *Ecological Monographs* 41: 250-269.
- Davies, B. E. (1971). Trace metal content of soils affected by base metal mining in the West of England. *Oikos* 22: 366-372.
- D' Itri, F. M. (1972). The Environmental Mercury Problem. The Chemical Rubber Company, Cleveland.
- Environment Canada (1976a). National Inventory of Sources and Emissions of Manganese, Fluoride and Vanadium - Summary of Emissions for 1972. Economic and Technical

Review Report EPS 3-AP-76-1. Ottawa.

Environment Canada (1976b). National Inventory of Sources and Emissions of Zinc, Cadmium and Arsenic - Summary of Emissions for 1972. Economic and Technical Review Report EPS 3 - AP-76-3. Ottawa.

Environment Canada (1977). Interlaboratory Quality Control Study No. 18 - Total Mercury in Sediments. Inland Waters Directorate, Water Quality Branch, Ontario Region.

Ferry, B. W., M. S. Baddeley and D. L. Hawksworth (1973). Air Pollution and Lichens. University of Toronto Press, Toronto.

Goodman, G. and T. M. Roberts (1971). Plants and soils as indicators of metals in the air. *Nature* 231: 287-292.

Groet, S. S. (1976). Regional and local variations in heavy metal concentrations of bryophytes in the north-eastern United States. *Oikos* 27: 445-456.

Gullvag, B. M., H. Skaar and E. M. Ophus (1974). An ultra-structural study of lead accumulation within leaves of *Rhytidiadelphus squarrosus* (Hedw.) Warnst. A comparison between experimental and environmental poisoning. *Journal of Bryology* 8: 117-122.

Hawksworth, D. L. and F. Rose (1976). Lichens as Pollution Monitors. *Studies in Biology* No. 66. Camelot Press, Southampton.

Heck, W. W. (1966). The use of plants as indicators of air pollution. *International Journal of Air and Water*

Pollution 10: 99-111.

Holden, H. (1971). Measurements of Air Pollution in Prescott.

Presented at National Society for Clean Air 38th
Annual Conference, Folkestone, England.

Huckabee, J. W. (1973). Mosses: sensitive indicators of
air-borne mercury pollution. Atmospheric Environment
7: 749-754.

Hutchinson, T. C. and L. M. Whitby (1974). Heavy metal
pollution in the Sudbury mining and smelting region
of Canada, I. Soil and vegetation contamination by
nickel, copper and other metals. Environmental
Conservation 1: 123-132.

John, M. K., C. J. Van Laerhoven, V. E. Osborne and I. Cotic
(1975). Mercury in soils of British Columbia, a
mercuriferous region. Water, Air, and Soil Pollution
5: 213-220.

Kahn, H. L. and D. C. Manning (1972). Background absorption
in atomic absorption spectroscopy. American Laboratory
43. (Reprint No. AA-691, Perkin-Elmer Corporation,
Norwalk, Connecticut).

Lakela, O. (1965). A Flora of Northeastern Minnesota.

University of Minnesota Press, Minneapolis.

Lazrus, A. L., E. Lorange and J. P. Lodge, Jr. (1970). Lead
and other metal ions in United States precipitation.
Environmental Science and Technology 4: 55-58.

- Le Blanc, F., G. Robitaille and D. N. Rao (1974). Biological response of lichens and bryophytes to environmental pollution in the Murdochville Copper Mine area, Quebec. *Journal of the Hattori Botanical Laboratory* 38: 405-433.
- Little, P., and M. H. Martin (1974). Biological monitoring of heavy metal pollution. *Environmental pollution* 6: 1-19.
- Linzon, S. N., B. L. Chai, P. J. Temple, R. G. Pearson, and M. L. Smith (1976). Lead contamination of urban soils and vegetation by emissions from secondary lead industries. *Journal of the Air Pollution Control Association* 26: 650-654.
- Mäkinen, A. and P. Pakarinen (1977). Comparison of some forest and bog plants in heavy metal surveys. *Ymparistö ja Terveys* 8: 170-180.
- McGovern, P. C. (1975). Effects of Sulphur Dioxide and Heavy Metals on the Wawa Area Soils and Vegetation, 1974. Ontario Ministry of the Environment, Sudbury.
- McGovern, P. C. and D. Balsillie (1975). Effects of Sulphur Dioxide and Heavy Metals on Vegetation in the Sudbury Area, 1974. Ontario Ministry of the Environment, Sudbury.
- Nie, N. H., C. H. Hull, J. G. Jenkins, K. Steinbrenner and D. H. Bent (1975). Statistical Package for the Social Sciences, Second Edition. McGraw-Hill, New York.

- Nieboer, E., H. M. Ahmed, K. J. Puckett and D. H. S. Richardson (1972). Heavy metal content of lichens in relation to distance from a nickel smelter in Sudbury, Ontario. *Lichenologist* 5: 292-304.
- Nordberg, G. F. (1974). Health hazards of environmental cadmium pollution. *Ambio* 3: 55-66.
- Olson, B. and R. Cooper (1973). Methylmercury and environmental health. *Journal of Environmental Health* 35: 436-442.
- Ontario Ministry of the Environment (1973). The Determination of Total Mercury in Biological Material. Toronto.
- The Ontario Public Interest Research Group (1976). Quicksilver and Slow Death. Waterloo.
- Pakarinen, P. and K. Tolonen (1976). Studies on the heavy metal content of ombrotrophic *Sphagnum* species. Proceedings of the 5th International Peat Congress (Poznan, Poland) 2: 264-275.
- Pakarinen, P. and K. Tolonen (1977). Distribution of lead in *Sphagnum fuscum* profiles in Finland. *Oikos* 28: 69-73.
- Rasmussen, L. and I. Johnsen (1976). Uptake of minerals, particularly metals, by epiphytic *Hypnum cupressiforme*. *Oikos* 27: 483-487.
- Rinne, R. (1975). A Survey of Heavy Metal Deposition in the Thunder Bay Area Via Analysis of Carpet-forming Mosses. Bachelor of Science (Honours) Thesis, Lakehead University, Thunder Bay, Ontario.

- Rowe, J. S. (1972). Forest Regions of Canada. Canadian Forestry Service Publication No. 1300. Department of the Environment, Ottawa.
- Rühling, Å. and G. Tyler (1968). An ecological approach to the lead problem. *Botaniska Notiser* 121: 321-340.
- Rühling, Å. and G. Tyler (1969). Ecology of heavy metals - a regional and historical study. *Botaniska Notiser* 122: 248-259.
- Rühling, Å. and G. Tyler (1970). Sorption and retention of heavy metals in the woodland moss *Hylocomium splendens* (Hedw.) Br. et Sch. *Oikos* 21: 92-97.
- Rühling, Å. and G. Tyler (1973). Heavy metal deposition in Scandinavia. *Water, Air, and Soil Pollution* 2: 445-455.
- Shacklette, H. T. (1965). Element Content of Bryophytes. Contributions to Geochemical Prospecting for Minerals. Geological Survey Bulletin 1198-D. U.S. Government Printing Office, Washington, D.C.
- Simola, L. S. (1977). The effect of lead, cadmium, arsenate, and fluoride ions on the growth and fine structure of *Sphagnum nemoreum* in aseptic culture. *Canadian Journal of Botany* 55: 426-435.
- Slavin, S., W. B. Barrett, and H. L. Kohn (1972). The determination of atomic absorption detection limits by direct measurement. *Atomic Absorption Newsletter* 11: 37-41. (Reprint No. AA-675, Perkin-Elmer Corporation, Norwalk, Connecticut).

- Smith, W. H. (1976). Lead contamination of the roadside ecosystem. *Journal of the Air Pollution Control Association* 26: 753-766.
- Stringer, P. W. and M. H. L. Stringer (1974). Air pollution and the distribution of epiphytic lichens and bryophytes in Winnipeg, Manitoba. *The Bryologist* 77: 405-425.
- Svensson, G. K. and L. Liden (1965). The quantitative accumulation of $^{95}\text{Zr} + ^{95}\text{Nb}$ and $^{140}\text{Ba} + ^{140}\text{La}$ in carpets of forest moss. *Health Physics* 11: 1033-1038.
- Tamm, C. O. (1953). Growth, yield and nutrition in carpets of a forest moss (*Hylacomium splendens*). *Meddel. Stat. Skogsforskn.* 43: 1-140.
- Tomassini, F. D., K. J. Puckett, E. Nieboer, D. H. S. Richardson, and B. Grace (1976). Determination of copper, iron, nickel, and sulphur by x-ray fluorescence in lichens from the Mackenzie Valley, Northwest Territories, and the Sudbury District, Ontario. *Canadian Journal of Botany* 54: 1591-1603.
- Tyler, G. (1971). Moss analysis - a method for surveying heavy metal deposition. Proceedings of the Second International Clean Air Congress. Ed. by H. M. Englund and W. T. Beery. Academic Press, New York.
- Tyler, G. (1972). Heavy metals pollute nature, may reduce productivity. *Ambio* 1: 52-59.

Tyler, G. (1974). Heavy metal pollution and soil enzymatic activity. *Plant and Soil* 41: 303-311.

United States Department of Commerce (1971). National Bureau of Standards Certificate of Analysis: Standard Reference Material 1571 - Orchard Leaves, Washington, D.C.

Wallin, T. (1976). Deposition of airborne mercury from six Swedish chlor-alkali plants surveyed by moss analysis. *Environmental Pollution* 10: 101-114.

Ward, N. I., R. D. Reeves and R. R. Brooks (1975). Lead in soil and vegetation along a New Zealand state highway with low traffic volume. *Environmental Pollution* 9: 243-250.

Warren, B. P. (1976). A study of mosses found along the roadsides and their possible significance as indicators of atmospheric pollution. *Journal of the Northhamptonshire Natural History Society and Field Club* XXXVII: 105-106.

Yeaple, D. S. (1972). Mercury in bryophytes (moss). *Nature* 235: 229-230.

	Thunder Bay ⁺ Ontario (mean ± S.D.)	Ignace (1) Ontario (mean ± S.D.)	Southern Scandinavia ⁽²⁾ (range)	Northern Scandinavia ⁽²⁾ (range)	Northeastern United States ⁽³⁾ (mean)	Northern Quebec ⁽³⁾	Mt. St. Anne Quebec ⁽³⁾
Sample Size (n)	22	25			86	2	1
Metal: Cd	0.50 ± 0.16 **	0.64 ± 0.21	0.8 - 1.5	0 - 1	0.93	0.40, 0.55	1.06
Cu	8.6 ± 2.0 ***	6.6 ± 1.4	8 - 12	5	9.6	5.4, 5.6	9.0
Fe	944 ± 377 **	692 ± 281	1 000	500			
Mn	318 ± 157	290 ± 128					
Ni	3.4 ± 1.1 ***	2.0 ± 0.6	3 - 8	1.5 - 2.0	9.4	4.6, 5.0	6.0
Pb	30.5 ± 10.7	29.4 ± 5.6	40 - 150	5 - 10	131	12, 38	123
Zn	65 ± 22	71 ± 41	80 - 110	30 - 40	62	42, 65	89
Species Analyzed	<i>Pleurozium schreberi</i>	<i>P. schreberi</i>	<i>Hylocomium splendens</i>	<i>H. splendens</i>	<i>Leucobryum glaucum</i>	<i>H. splendens</i>	<i>P. schreberi</i>
Sample Size	22	25					26
Metal: Hg	0.092 ± 0.031	0.061 ± 0.017	0.20 - 0.40	0.05 - 0.10	<0.05 - 2.0	<0.05 - 0.6	0.11
Species Analyzed	<i>P. schreberi</i>	<i>P. schreberi</i>	<i>H. splendens</i>	<i>H. splendens</i>			<i>Dicranum scoparium</i>

Cape Bon Quebec ⁽³⁾	Smoky Mts Tennessee ⁽³⁾	Rural England ⁽⁴⁾	Rural Scotland ⁽⁴⁾	Rural Denmark ⁽⁵⁾ (mean)	South-west Wales ⁽⁸⁾ (range)	Brooks ⁽⁷⁾ (range)	Southern Finland ⁽⁸⁾ (mean)
1	-			50			
0.64	0.68	0.4	0.6	0.40	1-1.8	0.2 - 5.0	
7.7	9.0			10	11-15	5.4 - 2.0	
				2 250		2 000	
				165		80 - 310	265
5.1	4.4				6.5-10	2 - 15	
50	107	116	91	50	50 - 65	30 - 300	28
47	53			95	74 - 108	45 - 132	60
<i>H. splendens</i>	<i>H. splendens</i>			<i>Hypnum cupressiforme</i>	<i>H. cupressiforme</i>		<i>P. schreberi</i>
Sweden ⁽¹¹⁾ (range)							
0.09 - 0.15							
<i>H. cupressiforme</i>							

	Thunder Bay ⁺ Ontario (mean ± S.D.)	Ignace (1) Ontario (mean ± S.D.)	Southern Scandinavia ⁽²⁾ (range)	Northern Scandinavia ⁽²⁾ (range)	Northeastern United States ⁽³⁾ (mean)	Northern Quebec ⁽³⁾	Mt. St. Anne Quebec ⁽³⁾
Sample Size (n)	22	25			86	2	1
Metal: Cd	0.50 ± 0.16 **	0.64 ± 0.21	0.8 - 1.5	0 - 1	0.93	0.40, 0.55	1.06
Cu	8.6 ± 2.0 ***	6.6 ± 1.4	8 - 12	5	9.6	5.4, 5.6	9.0
Fe	944 ± 377 **	692 ± 281	1 000	500			
Mn	318 ± 157	290 ± 128					
Ni	3.4 ± 1.1 ***	2.0 ± 0.6	3 - 8	1.5 - 2.0	9.4	4.6, 5.0	6.0
Pb	30.5 ± 10.7	29.4 ± 5.6	40 - 150	5 - 10	131	12, 38	123
Zn	65 ± 22	71 ± 41	80 - 110	30 - 40	62	42, 65	89
Species Analyzed	<i>Pleurozium schreberi</i>	<i>P. schreberi</i>	<i>Hylocomium splendens</i>	<i>H. splendens</i>	<i>Leucobryum glaucum</i>	<i>H. splendens</i>	<i>P. schreberi</i>
	Thunder Bay, Ontario ⁽¹⁾ (mean ± S.D.)	Ignace, ⁽¹⁾ Ontario (mean ± S.D.)	Southern Scandinavia ⁽²⁾ (range)	Northern Scandinavia ⁽²⁾ (range)	Brooks ⁽⁷⁾ (range)	Rural Maine ⁽⁹⁾ (range)	Smoky Mts. Tennessee ⁽¹⁰⁾ (mean)
Sample Size	22	25					26
Metal: Hg	0.092 ± 0.031	0.061 ± 0.017	0.20 - 0.40	0.05- 0.10	<0.05 - 2.0	<0.05 - 0.6	0.11
Species Analyzed	<i>P. schreberi</i>	<i>P. schreberi</i>	<i>H. splendens</i>	<i>H. splendens</i>			<i>Dicranum scoparium</i>

Cape Bon Quebec ⁽³⁾	Smoky Mts Tennessee ⁽³⁾	Rural England ⁽⁴⁾	Rural Scotland ⁽⁴⁾	Rural Denmark ⁽⁵⁾ (mean)	South-west Wales ⁽⁸⁾ (range)	Brooks ⁽⁷⁾ (range)	Southern Finland ⁽⁸⁾ (mean)
1	-			50			
0.64	0.68	0.4	0.6	0.40	1-1.8	0.2 - 5.0	
7.7	9.0			10	11-15	5.4 - 2.0	
				2 250		2 000	
				165		80 - 310	265
5.1	4.4				6.5-10	2 - 15	
50	107	116	91	50	50 - 65	30 - 300	28
47	53			95	74 - 108	45 - 132	60
<i>H. splendens</i>	<i>H. splendens</i>			<i>Hypnum cupressiforme</i>	<i>H. cupressiforme</i>		<i>P. schreberi</i>
Sweden ⁽¹¹⁾ (range)							
0.09 - 0.15							
<i>H. cupressiforme</i>							