

Fall 2017

Adjustable Height Table Chassis

Trevor Watkins
watkinsts@live.com

Follow this and additional works at: <http://digitalcommons.cwu.edu/undergradproj>



Part of the [Mechanical Engineering Commons](#)

Recommended Citation

Watkins, Trevor, "Adjustable Height Table Chassis" (2017). *All Undergraduate Projects*. 45.
<http://digitalcommons.cwu.edu/undergradproj/45>

This Undergraduate Project is brought to you for free and open access by the Undergraduate Student Projects at ScholarWorks@CWU. It has been accepted for inclusion in All Undergraduate Projects by an authorized administrator of ScholarWorks@CWU. For more information, please contact pingfu@cwu.edu.

Adjustable Height Table

By

Trevor Watkins

TABLE OF CONTENTS

Abstract.....	4
Introduction.....	4
Motivation.....	4
Function Statement	4
Requirements	4
Success Criteria.....	4
Scope.....	4
Final Success.....	5
Design and Analyses.....	6
Approach: Proposed Solution	6
Benchmark	6
Performance Predictions	7
Description of Analysis	7
Scope of Testing and Evaluation	7
Analyses.....	7
ACME Threads Analysis (Figure 4).....	7
Leg Structure (Figures 8-16).....	8
Moment Equations (Figure 5).....	9
Column Buckling (Figures 7 & 8).....	9
Stress Concentrations	9
Device: Parts, Shapes and Conformation	9
Ergonomics	9
Technical Risk Analysis, Failure Mode Analysis, and Safety Factors	10
Methods and Construction	10
Description.....	10
Sub-Assemblies	10
Table Rest (Figure 17)	10
Stand (Figure 16).....	10
Feet (Figure 15).....	10
Acme Locator (Figure 18).....	11
Assembly (Figure 18).....	11
Manufacturing Issues	11
Testing Method	11
Introduction.....	11
Method	12
Deliverables	12
Budget/Schedule/Project Management.....	13

Introduction.....	13
Budget.....	13
Schedule.....	13
Project Management.....	13
Discussion.....	14
Fall Quarter.....	14
Initial Design.....	14
Designing the Raising/Lowering Mechanism.....	14
Winter Quarter.....	15
Manufacturing.....	15
Spring Quarter.....	16
Continued Manufacturing.....	16
Testing.....	17
Conclusion.....	17
Acknowledgements.....	17
.....	Appendix A – Analyses
.....	18
.....	23
Appendix B – Drawings.....	24
Appendix C – Parts List.....	28
Appendix D – Budget.....	28
Appendix E – Schedule.....	29
Appendix F – Expertise and Resources.....	30
Appendix G – Testing Data.....	30
Appendix H – Evaluation Sheet.....	30
Appendix I – Resume.....	31

ABSTRACT

Having the ability to change a dining table between a sitting and standing position is a niche feature. This feature was created for people that play board games regularly at a table, or for people who require use of a dining table as a standing work area. The mechanism that the table works by is using an acme threaded rod as a lead screw, with two timing belt pulleys driving the shafts up and down which cause the raising and lowering of the table. These pulleys were machined to incorporate an ACME threaded bolt which was welded into each pulley. Due to the lead angle on the acme shafts they are self-locking which means that there does not need to be a secondary holding mechanism to prevent the table from falling once it is raised. It was designed to hold a 600 pound distributed load across the surface of the chassis with a designated factor of safety of 1.3, which through nondestructive testing the chassis was able to support. The result is a table which can be used as a normal sit down dining table, with as little interference to comfort as possible, and can then be raised up a total of 2 feet to become a standing work table.

INTRODUCTION

Motivation

There has been much research done about standing desks and their benefits, the philosophy behind those desks has never been considered to be implemented to a dining table when people are going to be using it for a long period of time.

Function Statement

Design a mechanical chassis that will support a table which can be raised, lowered, and set at desired heights.

Requirements

The goal is to create a chassis which:

- Table must be able to support a 600lbs distributed load.
- Is able to be operated by a single person, human powered requiring no more than 40 lbs of force
- Weighs no more than 200 lbs. fully assembled.
- Can be assembled and disassembled using hand tools having no component weighing more than 50 lbs., in under 30 minutes.
- Cost no more than \$300.
- Has a travel distance of 2.5 ft.
- Can be ran without lubricated parts other than self-lubricating bearings

Success Criteria

When this product is completed the success will be measured by the ability to load 600 pounds onto the table without the chassis breaking, or tipping over, at its maximum height.

Scope

The scope of the project is to have a completed working prototype lifting chassis for a dining table.

Final Success

The ultimate success of this project hinges on being able to accurately analyze and predict the material properties and strengths of various metals while trying to remain under weight requirements.

DESIGN AND ANALYSES

Approach: Proposed Solution

The first idea that was conceived was a two-legged chassis where a centrally located bevel gear would drive two bevel gears on opposite sides, those bevel gears would transmit

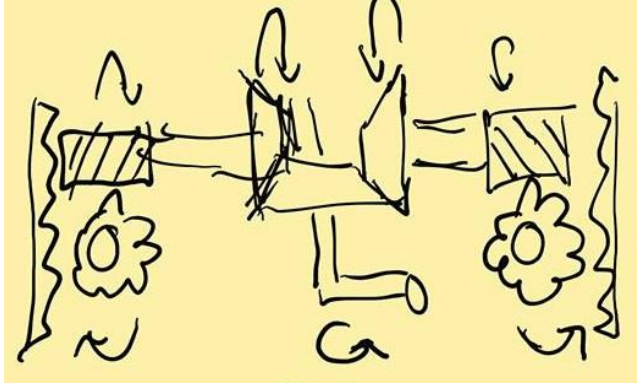

Figure 1 - Sketch of first proposed solution

power to two worms, with opposing orientations as to drive in the same direction, these would connect to a worm gear which would then mate with a rack to convert the radial motion into linear motion. (Fig.1) This idea was quickly dismissed due to the logistics of getting a worm gear which would mesh with a rack.

The second design that was being pursued was also a two-legged design, however the method of linear movement was going to be driving a worm gear up and down an acme threaded shaft, this being

inspired by how a worm gear screw jack works. This design has proven to be very capable at supporting large axial loads, it also allows for simplification of power transferal, being able to attach two worms to a single shaft to drive both gears.

This design would have resulted in a very sturdy design, but with the ratio of the gearing, combined with the expense of finding a proper worm gear resulted in this design not being viable.

The third design is using the same acme threaded rod, but instead of being driven by a worm gear, it is driven by a timing belt drive. This design increases the complexity of the frame, since a third pulley needs to be added to run the drive. This increased complexity is going to be offset by the ability to get the parts needed for it at a much lower cost.

Benchmark

As mentioned there are many designs for desks which address a similar problem, some of which are even manually powered as this project is intended to be designed. Looking at specifications, as well as disassembly of those products and comparing them to what is able to be created with this project will be a solid place to take inspiration and criteria from. Another benchmark will be comparing commercially available worm gear screw jacks (Fig.2) to the proposed solution.

<http://joycedayton.com/products/machine-screw-jacks/500-lbs-machine-screw-jacks>, Model WJ500.

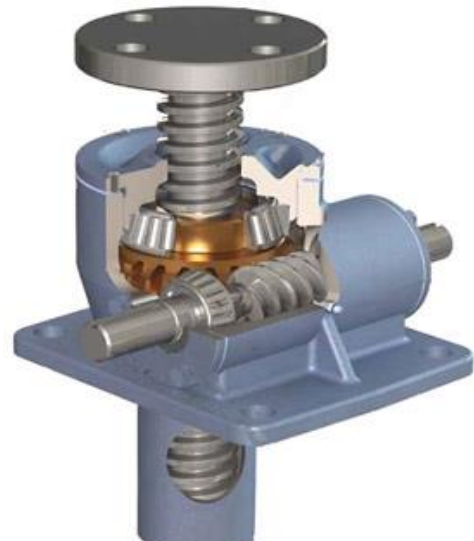

Figure 2 - Worm Gear Screw Jack cutaway picture, available from Joyce Dayton

Performance Predictions

With the materials that have been chosen performance predictions are that the given values which are being aimed to come under will be achievable with greatly exceeded results. Analysis are in Appendix A for complete overview.

Description of Analysis

There will be four aspects of analysis that will be conducted for this project as follows:

- Column loading stresses in associated with acme threads, calculating max shear force able to be supported.
- Stress analysis of members on a statically loaded table accounting a distributed load.
- Stress concentrations around any fixtures which are needed to affix hardware to and maximum allowable stress in those areas.

All analysis calculations are worked and presented in Appendix A.

Scope of Testing and Evaluation

Due to the fact that the finished product is going to be a working prototype the amount of testing that is going to be able to be done is less than what would be appropriate if the product was going to be taken and produced for consumers. Part destruction to determine ultimate strength or testing to a mode of failure for column stresses of the chassis would be the ideal scope of testing, but doing these tests would represent a substantial material cost which is attempting to be mitigated in this project, though some measure of that testing could be accomplished cheaply if material is able to be acquired through donations or direct supplier.

The inability to test ultimate strengths and loads to failure is going to require theoretical calculations and simulations be thorough, as well as design around a high safety factor to account for any possible unknowns in the analyses.

Analyses

In this section a description of how each of the analyses was conducted will be explained, and will refer to a set of equations in Appendix A.

ACME Threads Analysis (Figure 4)

When axially loading ACME threads there are three primary considerations, the thread shear rating, external thread relief tensile failure, and internal thread relief tensile failure. For the proposed design the thread shear rating is the only important calculation due to there being no end condition to define a box and pin.

Calculating this rating is started with the equation:

$$\text{Shea Area Per Inch} = \pi D_1 \max [0.5 + n \tan(14.5^\circ) (D_2 \text{ min} - D_1 \text{ max})]$$

Where: Dmax = maximum minor diameter of the internal thread, Dmin = minimum pitch diameter of the external thread, and n = Threads Per Inch. Take this value and multiply it by how many inches your threads are acting across to find the total shear area.

Once this value is found the material properties of the metals being used are looked at, and using the max shear stress theory you derive the shear strength of the material by dividing its minimum yield strength in half. Multiplying the total shear area value by the shear strength of the material results in getting the maximum axial force to failure.

Leg Structure (Figures 8-16)

The images in Appendix A are a result of running stress analysis tests in Solidworks in order to discover what kinds of stresses are involved in both distributed and concentrated loadings for four-legged tables, pedestal tables, and multi-pedestal tables.

In regards to the four-legged table, the stress simulations showed that out of the three types, there was the least amount of stress concentrations throughout the table, in very few areas getting to a green level of stress, and nowhere other than the undersides of the legs getting to yellow or red stress levels. In addition, because there are supports on the ends of the table, no amount of concentrated load at the edge of the table will cause a moment resulting in the table flipping. In this table design, there are two major cons which arise, the first of which having to do with the complexity of creating and attaching four legs to a table, the second is a decrease in the usable leg room of those sitting around the table. The increased complexity is related to creating four symmetrical legs, and attaching those legs so that the table sits on all four of them equally, these are both manufacturing challenges. In addition to this there is the concept that if you have a structure with four legs, it will never be statically determinate, because at any time only two of the legs could be supporting the load. In general, three legged designs are the best because you can create a statically determinate shape and design to a closer specification, these shapes are possible with pedestal designs. The leg space issue makes impractical to have two people sitting on one narrow edge of the table, even for situations where not much table space is required per person.

With the pedestal table, the results of the tests show a plethora of problems when creating a table at the scale of being used as a primary dining table. There are many areas with large stress concentrations even when only using the distributed loadings, and when concentrated loadings are examined the results are even worse. The pros and cons of this design, to the four-legged designs are inverse, with the pedestal table fairs incredibly badly in stress loadings, but being the best from a simplicity and leg room design perspective. But because the stresses are such a large issue those pros are outweighed handily. Also, with this kind of table, the forces generated by the moment need to be taken into account.

The multi-pedestal table, as with most solutions, the best comes in the form of a compromise. Looking at the tests for the multi-pedestal table there is certainly more stress concentrations in the design versus the four-legged design, but none of the stresses are to the level where they are showing up as yellow or red as they had in the single pedestal table. With this design the stress levels have been brought down to a reasonable level, and with the sacrifice of some of the stability there are gains in the simplicity of design, and the leg room available to people sitting around the table.

These results have made it clear that the best design is going to be a multi-pedestal table, as the stress concentrations are not untenable, while providing a simplification of only needing two legs, which for having the variable height tied to the legs, the fewer legs the better. The increased amount of leg room is a benefit of usability, but ultimately it is merely a side effect and not a primary reason for choosing said design.

Moment Equations (Figure 5)

Another mode of failure for the device which was brought to light with the stress analysis of the various leg structures was that the moment generated by a concentrated load needed to be taken into account. Using the Law of levers, using the support closest to the edge of the table as the support the moments can be taken on either side assuming the weight of the final table being 200lbs. With that weight, the results showed that it would take over 1670lb force at the edge of the table to break static equilibrium thus causing the table to lift. With a safety factor of 2.5, the recommended load for the side of the table would be 668lbs, which is just over the target specifications.

Column Buckling (Figures 7 & 8)

This design is going to use two ACME threaded shafts upon which will support a surface and distributed loads. The use of Euler's Column Formula is appropriate as the shafts will be thin compared to the length that they will be extended.

The formula for determining the buckling load is:

$$P_{cr} = \frac{\pi^2 EI}{(KL)^2}$$

Where:
E = Modulus of elasticity of the column material
I = minimum area moment of inertia of the cross section of the column
L = unsupported length of column,
K = column effective length factor

The parameters for this design will use L = 2.5ft, as that is the amount of travel that is desired and will be the point of greatest stress. K= 0.5, as both ends of the column will be fixed. I will be found using the root diameter of the acme threaded shafts and calculated for moment of inertia for a cylinder. With the aid of Solidworks model it was determined that the inner diameter of the threaded rod is 0.55in. Using the root diameter gives the smallest measurement and this the most likely point of failure for the calculations. E is 30,000,000psi as the material being used is steel. With these values, and a design factor of 2.5 the recommended load for a single column is 816lb. There are two of these rods which will increase the ability of load to be taken.

Stress Concentrations

Using the models from the table leg structure analysis it can be seen the areas that will have the greatest stress on them will be in the two legs of the table and that those are the areas that will have to have a greatest focus placed on them.

Device: Parts, Shapes and Conformation

The results of the empirical research done on the various table leg designs and the statics behind them have led to the conclusion that the best table design to pursue is one with a multi-pedestal arrangement. Current parts that are being considered are square tubing to make up the bulk of the chassis, three timing belt pulleys, housings for two of the pulleys, and acme threaded shafts with end fasteners for the assembly the table will rest on.

Ergonomics

Design consideration are being taken from the ergonomics guide by OSHA specifically related to the office space, as most other OSHA ergonomics are closely related to how you work,

instead of how the spaces and products you use are related to ergonomic designs. These are some of the guidelines that will be looked at for this product:

- Table edges are rounded to prevent contact stress when resting on.
- Table should be easily adjustable without inducing back strain.
- The height should not be raised above chest unless precision work is being done, and more frequently table should be adjusted to just below the elbow when standing.

Technical Risk Analysis, Failure Mode Analysis, and Safety Factors

After the creation of this product the greatest potential risk to occur would someone sitting on the chassis, it either flipping or breaking, and the person falls a maximum of 5ft to the ground.

With the analyses that have been done, and the materials that have been selected the most likely mode of failure will be flipping the table which would be caused by a concentrated loading being placed on one of the far edges of the table. Looking at Figure X, using the Law of Levers, it can be seen that with the given measurements for the final design it would take a weight of 1600 pounds at the very edge of the table in order to cause the table to lift off the ground.

In order to avoid this failure modes, and accounting for a safety factor of 2.5, the recommended maximum loads for the table is to not load more than 640lbs on one edge of the table.

METHODS AND CONSTRUCTION

Description

This project was conceived, designed, and analyzed at CWU. Having the requirements of working within the constraints of the universities resources most parts are going to be stock parts acquired through manufacturers and modified as needed to fit the project.

Sub-Assemblies

This project is made up of five sub-assemblies, each having drawings in Appendix B.

Table Rest (Figure 17)

The entirety of the table rest is going to be made of steel tubing fastened together with brackets, nuts, and bolts to keep in line with the ability to disassemble. The holes for the steel tubing will be drilled on a standard press drill as high levels of accuracy are not critical for this portion of the chassis.

Stand (Figure 16)

The steel tubing for this part is going to be welded together in the areas that they meet, this is being done because for this sub-assembly accuracy is going to be important, and having this portion able to be disassembled could lead to misalignments between the belt pullies.

Feet (Figure 15)

This drawing is representative of an approximation of standard restaurant table legs measuring 36inx36in. This is done to aid in the overall look of the assembly, but the standard legs will be ordered from an online distributor.

Acme Locator (Figure 18)

This part is being used to fix horizontal plane of the ACME threaded rod in a more restrictive manner than them able to be anywhere in the square tubing. It is also being used to locate the vertical component of the sheaves themselves, and so when rotating they will exert force onto the top or bottom and then drive the rod up or down.

Assembly (Figure 18)

For assembly, the feet will first be attached to the stand to offer a base to work off of. Then the plates and housings will be fixed to the stand. Once those are attached the pulleys themselves will be placed into the housing. The way the housing is designed is to locate the pulleys via constraining where the threaded rod can move, by restricting the rods movement in only vertical positons the pully itself does not need to be supported. Once the pulleys are in place the threaded rods will be put through the housing and threaded through the pulleys until they are at their max depth. Once those are in place the table rest will need to be placed onto the stops and secured to the threaded rods to make sure they no longer rotate, as the rotation is needed to drive the linear movement of the table.

Manufacturing Issues

There are two large manufacturing problems which have arisen in the design of the table. The first of the two problems are the housings that are needed to locate the two pullies which are the driving elements for the acme threaded rods, this need is caused due to the to the fact that the center hole of pullies is typically what is used to locate those types of parts, but because of the fact that the center of the holes is being used to traverse the rods they need to be located in another fashion. This being an unusual situation there are no stock parts which are suitable for the task. This is going to result in needing to manufacture the housings for the pullies. The only thing which makes sense for making those housings will be casting them individually.

The second problem is for the design the table leggings, which are going to be three legs on each pedestal. The easiest solution for this problem would be to buy previously manufactured fixtures and attach them to the table. But this brings the problem of having to fit something premade into something that it was not intended, mainly attaching those to a square tube, where most tables made with those kinds of stands are circular pedestals. This will be resolved by capping the square tubes where the legs will be attached and then running a bolt through them and through the hole that is made for the leg stands themselves.

TESTING METHOD

Introduction

For the testing of the table, there were three major aspects to be tested, how much force it would take to turn the pully which raised and lowered the table, will the table be able to support an 800 pound load, and what point load would it take to begin tipping the table.

The predicted performance of these tests were it would take 20 pounds of force to break static friction to raise or lower the table, the table would be able to support the 800lb load, and the point load that would start to tip the table was 85 pounds.

Data acquisition would be manual readings off of scales, as well as counting the total weight to be put onto the table.

These tests took place over the course of four weeks.

Method

For these tests which were all intended to be non-destructive the resources which were required included a digital hand scale, 800 lbs worth of modular weights, a plywood board, and a power drill for operation.

Data capture was done manually, during the testing process, when the criteria for the test had been met, the highest value on the digital scale was recorded, the test was reset and then ran again. Each test was repeated four times to get multiple data points.

Force to Turn: This test was done outside of the full assembly, where the ACME thread pulley system was clamped to a surface. Weights were loaded onto the ACME rod, then with a handle attached to the pulley, using the digital scale to do the pulling force was slowly applied until the static friction of the pulley was broken and began to rotate. This test was done unloaded, as well as with 20lbs, 40lbs, and 60lbs of weight.

Point Load Moment: When the table had been completely assembled, a strap was attached to the side of the table at the center, where a force being applied would create the largest moment in relation to the center of mass of the table. The strap would then be pulled directly down with the scale. As soon as the table legs lifted off the ground the force was recorded.

Operational Load: This was a simple go-no go test to determine if that table would remain structurally sound when loaded up to 800 pounds and then jostled to see if the weight and jostling would damage the ACME threads, or unbalance the table at all. After getting a piece of plywood to lay across the table weights were taken and placed evenly along the table surface, making sure not to create a dynamic loading situation, and making the weight distributed as evenly as possible. The table was jostled, there were no structural deformations during the loading, and after unloading the table the pulley mechanism worked as intended, after disassembling there was no damage that could be seen on the threads.

The limitations that I encountered related primarily to the fully loading of the table. Because of the structure, the critical stresses were occurring inside of the threads of the Acme threads, and there was no way to get meaningful data from that location as the only thing that would be available for that were strain gauges, and the ones that we had access to had to have a long area of adhesion which was not possible to acquire. The other limitation came in the form of safely being able to load 800lbs onto the table. The primary idea was to use the uniform bulk container from the Thermodynamics lab, utilizing the crane as a safety net to load water weight onto the table, but because of the construction of the UFB cage, the crane would not be able to pick it up from the top and there was no timely way to figure out how to load it in another fashion.

Precision for the two tests which involved measurements were not wonderful, with a spread of 2-3lbs between all of the tests, accuracy however was reasonable, only being about 8% off from calculated values.

Deliverables

Force to Turn: How much force it takes at various weight. Calculated at 60lb load: 15lbs. Success: Less than 20lbs.

Moment: Force it takes to begin to tip table. Calculated load was 85lbs at the point of greatest moment. Success would be anything within 75lbs, actual values were ranging from 75lbs to 79lbs.

Maximum load: Load table up to 800lbs without compromising structure. Calculations supported that this value would be supported. Success criteria was that the table would not fail under such a load. Due to some errant math, loaded the table up to 853lbs, the structure was sounds and did not fail.

BUDGET/SCHEDULE/PROJECT MANAGEMENT

Introduction

This project has three major areas where risk factors come into play, those being staying within the outlined budget, scheduling things appropriately to have the product finished, and managing the construction of the project in such a way that it meets the analyzed criteria that have been determined.

Budget

A parts list is shown in Appendix C. The parts list details their identification, description (specifications), sources and cost as shown in Appendix D. Relatively low-cost parts like nuts and bolts will be acquired through educational support through Central.

Some of the assemblies will require welding which will be done using the materials and tools offered by Central labs, the lead engineer on the project will be going through Welding classes during the same time as construction of the chassis that will need welded parts.

Labor costs are not going to be part of the equation as none of the project is going to be outsourced to others, the only labor cost is going to be time which is covered in the schedule in Appendix E.

The current total cost of the project is estimated to be about \$363, this includes the material costs covered in the budget appendix. This cost could be reduced as a result of ordering products through the school and getting the discounts which are tied to doing so, and also in doing so should hopefully avoid shipping costs associated with receiving the parts as those numbers are not easily attainable and have been omitted.

Schedule

The scheduling issue has to do with creating the table chassis that can meet the performance specifications within a reasonable time-frame. The schedule for this project is constrained by the MET 495 course and is shown in Appendix E. A schedule guide has been provided. This project will be completed by the last week of the third quarter.

Project Management

This project will succeed due to the availability of appropriate technical expertise and resources. Test equipment is available to use for both stress testing of parts, as well as doing tests relating to finding the actually tipping point of the table.

The principal engineer will provide expertise in areas of three-dimensional modeling, use of engineering equipment including lathes, drills, and mills, as well as welding, and proper analysis of the design, their resume is shown in Appendix J. Help will be acquired from staff of CWU in relation to running of testing equipment, the possibility of running CNC related machinery.

DISCUSSION

Fall Quarter

Initial Design

When the project was announced immediately ideas for creating some sort of table came to mind as it is something that has many structural elements and has a small enough scope to be feasible in the allotted time with the resources that were available. To increase the engineering merit of the design different mechanisms were conceived that would give the table the ability to be raised and lowered by a single person.

The first ideas were for the table to be raised and lowered via pneumatics or hydraulics as raising and lowering things are very standard uses for those kinds of technology. When examining those prospects the question arose of how the table was going to be used, as the answer to this question was that it was to be used in a dining area would either of those two methods be practice for the situation.

Pneumatics would require a form of compressed air to be integrated into the system in order to power the raising of the table, which would by extensions require some form of external power for the system which would go to an air compressor. This revealed that the system should be self-contained, not needing any external inputs other than human.

Hydraulics offered the potential to have a system that is self-contained, however there was the large issue with hydraulics that they are prone to leakage and have lots of oil and lubricants as part of their use and maintenance. For a table that has plans of residing in a dining room and being used primarily as a dining table having something that could lead to a large spill and cleanup was not going to be desirable.

With the two most obvious choices not promising as pursuable avenue Professor Beardsley was consulted as to what his thoughts were for possible solutions to the project. He had suggested having a set of multiple leaf springs of varying strengths attached to a frame which could then be attached to the table when it needed to be raised, the springs aiding in the raising of the table. While this idea was a potentially elegant solution, in the way that it was being thought of, it would have sacrificed most of two sides of the table for the leaf springs which would have resulted in having zero leg room, not ideal for a primary dining table.

The design which seemed to have the most merit was one where a driving power be translated to some mechanism that would translate a rotational movement into a lateral movement.

Designing the Raising/Lowering Mechanism

As covered in the introduction section of the report the initial design was one where a worm gear would mesh to both a worm as well as a rack with specialized bars which would allow meshing with the worm gear. While this kind of design exists (Figure 3), it would not be the most

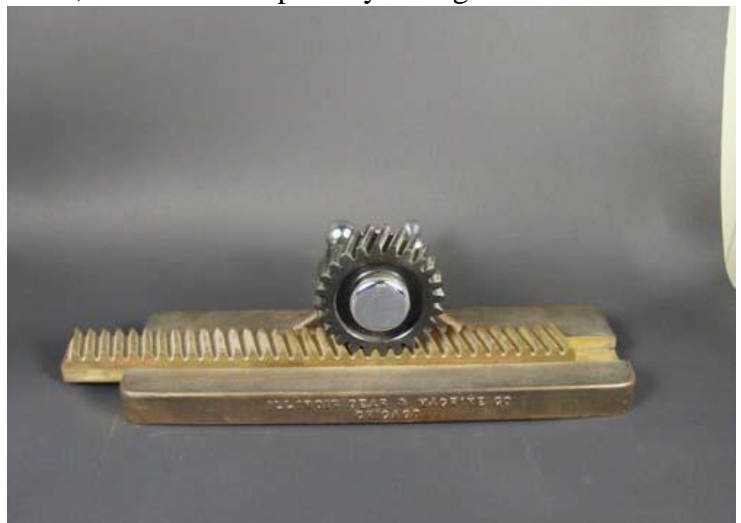

Figure 3 - Worm gear meshed rack

applicable, easy to analyze, or strongest possible solution.

The second design took the idea of a lead screw similar to printers as well as precision manual machining tools such as the engine lathe and horizontal mill. The idea would be to have a worm driving a worm gear which would translate that rotation up and down an ACME threaded shaft. There were two large issues with came with this design, the biggest was the cost of finding an appropriately sized worm gear pair that would allow further machining of an ACME thread in the gear. The second problem was that each rotation of the worm would only be a fraction of a rotation on the gear, which in turn would only raise it a fraction of an inch, with the ACME thread being used being 6 threads per inch, it would have taken nearly 40 turns of the handle to raise the table a single inch. With a travel of 2.5 feet, the turns required would have been over 1,000 to get it to the full height.

The final design will be using the same mechanism of having a driving force rotating around and acme threaded rod which will raise and lower the table. The change being that instead of using a worm gear it would be driven with timing belt pulleys, this fixes the issues of both cost, each pulley only costing \$34.60 each, instead of the hundreds per that it would have cost to get worm gear pairs. This design also greatly lessens the number of turns required to get to maximum height, with the ratio being 1:1, the handle will only need six turns to be raised an inch in height.

Winter Quarter

Manufacturing

The first aspect of this build was ordering all of the materials that were going to be required for the build. The prices for the raw materials were well accounted for in the budget. However, when going to order the pre-fabricated legs the supplier that had been designed accounting for was going to charge nearly \$150 for two of the legs, which were only going to be \$50 for the pair of them. The other part which was not purchased during this quarter was the timing belt itself, as there were a few smaller design changes which would have the result of changing the needed belt length, it was decided that finishing fabrication and taking a live measurement of what would be needed would be preferable to blindly buying the calculated length and having it possibly not work.

Once all the raw material arrived the first thing that was fabricated was the table stand itself. This was a simple but time consuming process cutting each piece to length, and then drilling both the small hole on one side to fit a bolt through, but also using a large step drill on the reverse side to have room for a socket to gain access to tighten the nuts and bolts to secure the brackets which are what the table rest is held together with.

The next process which was done was machining the timing belt pullies to fit the purchased acme threaded nuts inside of them so that they will be able to be the driving mechanism for table stand. What Ted Bramble had suggested was instead of machining a hex into the timing belt pully to turn down the hex nuts themselves to be round and then machine the hole in the pullies to be larger. This turned out to be a much easier process than attempting to machine an inside hex in the pullies. The only problematic aspect was getting a work holding fixture for the bolts. The solution that we came up with was to use an emergency mandrel and machine it to the size that it needed to be to securely hold the threads of the bolts. The turning of the bolts, and drilling of the timing belt went well and without fanfare.

After completing the machining the bolts were able to snugly fit into the pullies. It was at the point that I got the rest of the tubing laid out for the creation of the stand, drilling the holes were the acme locators would be fixed to the stand, as well as the hole and slot for the timing belt rollers, the slot one also being used as the tensioner. When this was completed this material, and the timing belt sheaves were brought to the welding lab where Matt Burvee and Stefan Schacht helped with welding everything together. The table stand went together without problem, the sheaves on the other hand had a major problem.

When welding the acme threaded nuts into the sheaves we threaded them onto a piece of scrap rod in order to make sure that they were aligned when they were welded in place, otherwise there was no making sure that there would be any alignment at all since there were two nuts that were being welded into the pulley. When both sides got tacked up the fit became tighter than was desired from the thermal expansion of the heat getting put into the metal from the weld. However, while the metal was still warm they were spinning on the rod. After letting them cool it became clear that they were going to completely seize on the rod. At this point nobody could come up with a solution other than to take one of the nuts out completely and run with a single nut welded into each sheave. This is what was done, and now calculations will have to be done to get an idea on the strength one weld will provide versus two for the materials that were used.

The final part which was fabricated were the ACME locators. From the holes on the stand itself, markings were scribed for where the holes needed to be placed in order to line up with the holes on the stand. The plate was then drilled for those holes, and taken to the welding shop to get connected. Stephan again helped in doing this. After the top and bottom pieces were welded with the supporting sides, brought them back to the machine shop and drilled holes into the center of them so that they could locate the x and y components of the build, the overhanging bits locating the pullies in the z axis so the only thing that can traverse is the acme rods in a linear fashion once they have a fixed end.

At the end of the quarter, because of not accounting for some of the extra bits that were going to be needed to make the project functional the budget ran out and the final assembly was being put off until the very first part of spring quarter, but all of the machining for the project is done, the rest will be assembly when the parts can be purchased.

Spring Quarter

Continued Manufacturing

After acquiring more funds the last parts were able to be ordered, the belt itself, as well as the legs for the table, and the bolts, nuts, and nylon spacers for the timing belt assembly. Two additional parts needed to be produced to assemble the entirety of the chassis, one which would allow the feet to be fastened to the frame, and a second to allow the mounting of the threaded rods to the table rest. The portion to allow the feet to fastened onto the rest was made with a small plate, which had a hole drilled through it. That hole then had a bolt put through it and welded. This plate was then welded to the bottom of the legs of the rest so that each leg had a threaded bolt sticking out of it, which would be put through the holes on each of the feet and then have a bolt which tighten to secure them.

The part used to fasten the table rest to the threaded rods was also made using a steel plate that was scrap in the machine shop. Holes were marked and drilled into the plate and the rest so that they matched. The plates were then bolted to the table rest and taken to the welding shop. There, the ACME threaded bolt that did not get used were threaded into one end of the rod,

and then laid onto the plates and squared. The bolts were then tacked and welded onto the plates. Welding was then used to tack the bolt and rod together to have the plate, bolt and rod become a single piece which, when not allowed to rotate by the fixed holes in the rest, will allow the single piece to translate up and down with the rotation of the timing belt system.

With the fabrication done the final assembly was able to be completed for the device and testing able to commence.

Testing

The testing which was outlined in the previous sections were done. The results of the moment test were significantly less than what was anticipated, which is likely due to the table weighing much less than what the calculated values were due to not having the tabletop itself as part of the construction.

CONCLUSION

A table chassis that has a human powered system to adjust the height of the table has been conceived, analyzed and designed that should meet the function requirements presented in the above sections of the proposal. This design has been of great interest to the principle engineer due to the fact that a dining table is a large part of their most participated hobby, as well as needing a table for the future. Engineering merit was met through structural analysis of the entire construction as well as well as specific parts such as the ACME threaded rod. Parts have been specified, most have been sourced and budgeted for acquisition. These parts and the processes that were done were all able to be accomplished within the confines of the Central Washington University labs and materials available to them. The device itself was able to support up to an 850lb load, a 1.4 times load greater than which was specified to account for a safety factor, the amount of force required to begin the timing belt system was within 5% of estimated values. The concentrated load to tipping was off by a factor of 2, this error is stemmed from the reduced weight of the chassis compared to the analysis which was done.

ACKNOWLEDGEMENTS

This project would not be possible without the mentorship of much of the staff of CWU including Charles Pringle, Craig Johnson, Rodger Beardsley, Scott Callahan, Ted Bramble, and Matt Burvee.

Stefan Schacht was a great help with the welding portions of the project.

All of the lab techs working throughout winter quarter to have the labs open for people to work in as much as possible was greatly appreciated.

APPENDIX A – ANALYSES

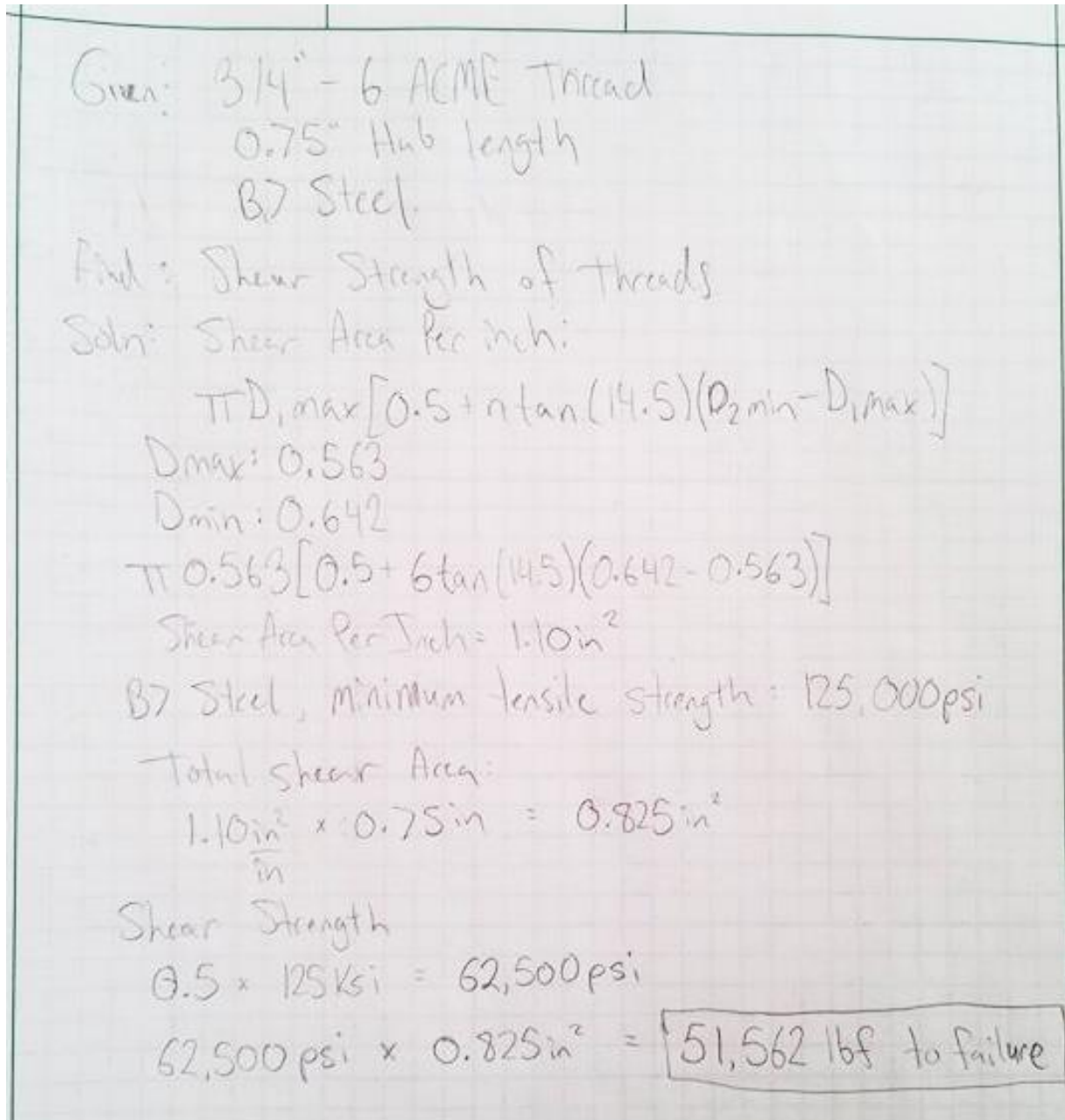
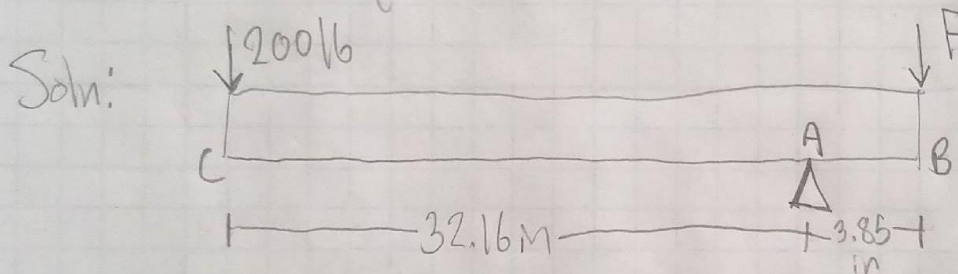

Figure 4 - Axial Load Shear Calculations for ACME threaded rod

Given: Table weight of 200lb, distance of 3.85m from support to table edge, distance of 32.16m from support to center of mass

Find: Max weight applied at table edge to sustain static equilibrium.



$$\sum M_A = 0 = 32.16m(200lb) - 3.85m(F)$$

$$6,432 lb \cdot m = 3.85m(F)$$

$$F = \frac{6432 lb \cdot m}{3.85m} = 1671 lb$$

Figure 5 - Concentrated load to determine weight needed to flip table.

Column Analysis

Input Page

Column Analysis

Length and end fixity

Column length	L =	30	in
End fixity coefficient	K =	.5	
Initial crookedness	a =	0	in
Eccentricity	e =	0	in
Applied load	P =	300	lbf

Material properties

Yield strength	Sy =	9500	psi
Modulus of elasticity	E =	30000000	psi

Cross section properties

Type of the column cross-section	Circle
Diameter	D = .55 in

Design factor

Design factor on load	N = 2.5
-----------------------	---------

Figure 6 - Input for Column Analysis

Output Page

Results:

The column is Short, straight

Area	A =	0.238	in ²
Neutral axis to outside	c =	0.275	in
Effective length	KL =	15.000	in
Radius of gyration	r =	0.138	in
Slenderness ratio	KL/r =	109.091	
Column constant	Cc =	249.668	
Critical buckling load	Pcr =	2041.582	lbf
Allowable load	Pa =	816.633	lbf
Maximum stress	σ =	8593.134	psi

No relevant formula at this moment to calculate Ymax

Figure 7 – Output for Column Analysis

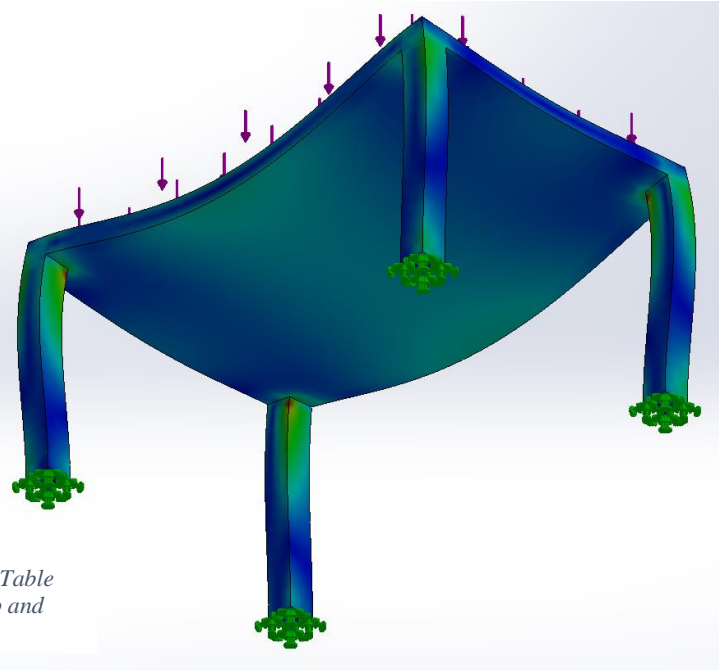
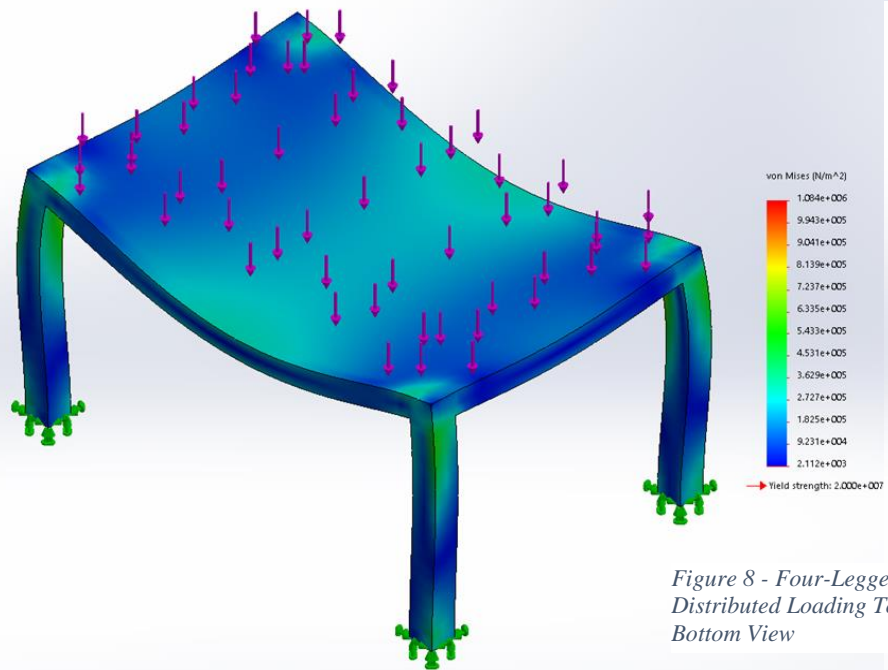

Figure 8 - Four-Legged Table
Distributed Loading Top and
Bottom View

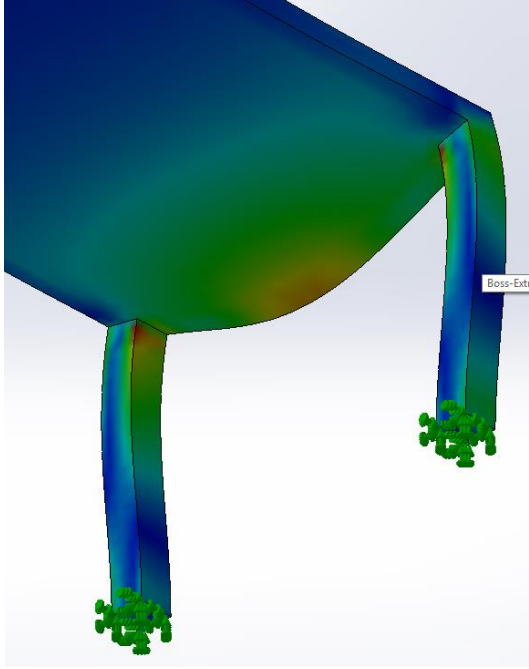
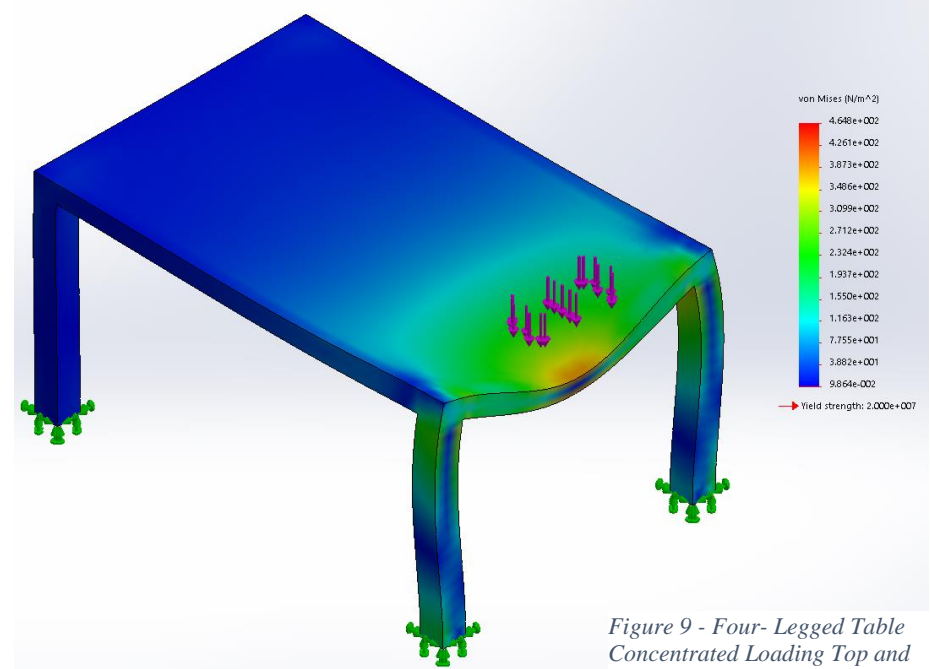

Figure 9 - Four-Legged Table
Concentrated Loading Top and
Bottom View

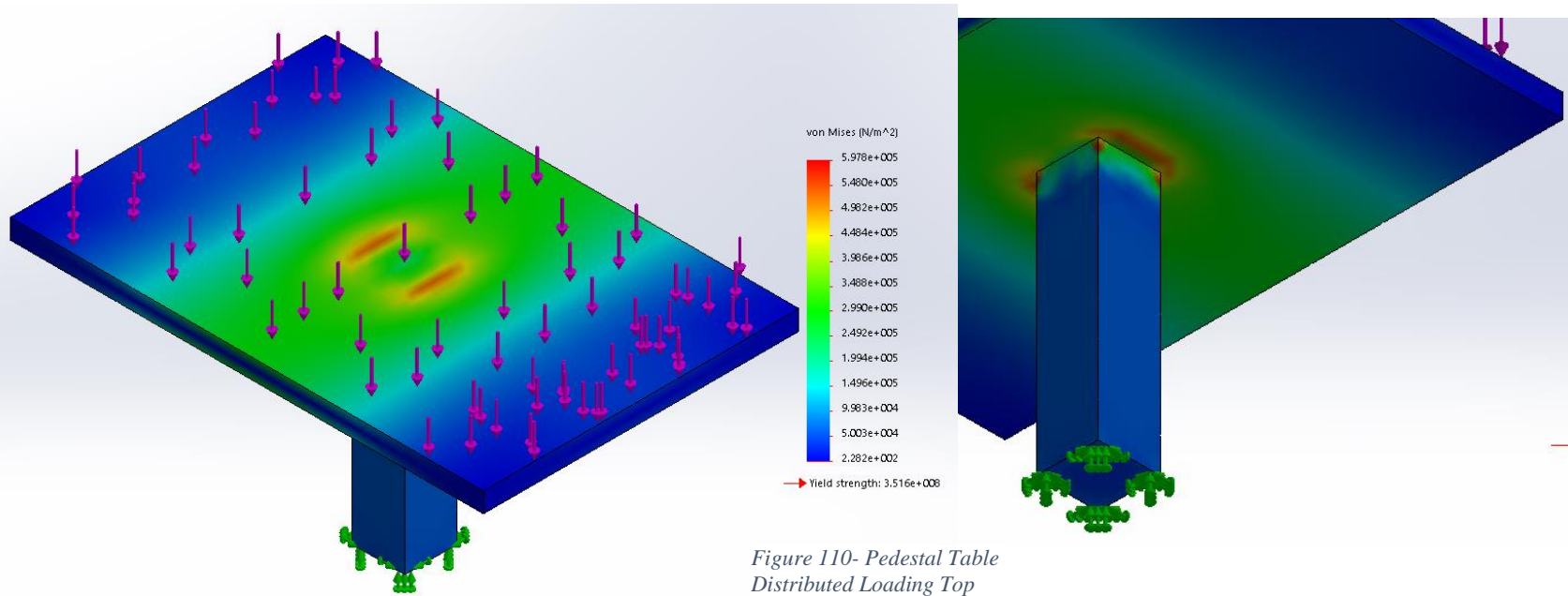

Figure 110- Pedestal Table
Distributed Loading Top
and Bottom View

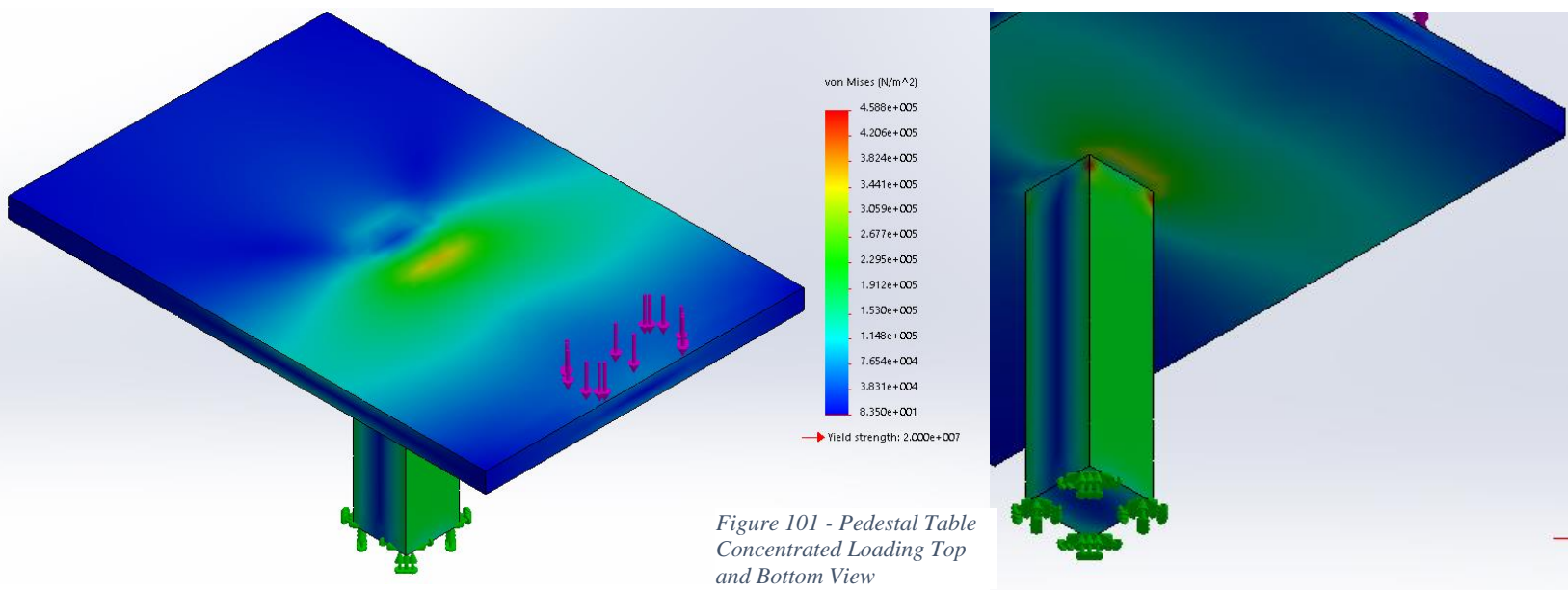

Figure 101 - Pedestal Table
Concentrated Loading Top
and Bottom View

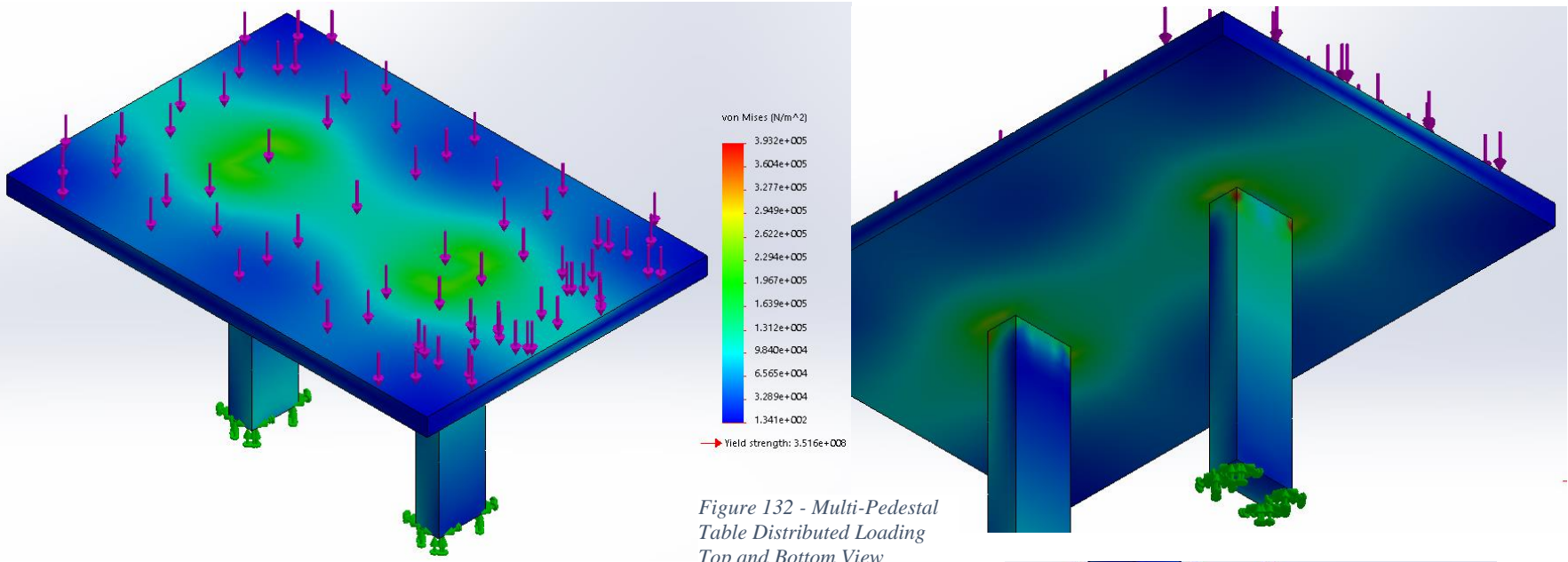

Figure 132 - Multi-Pedestal Table Distributed Loading Top and Bottom View

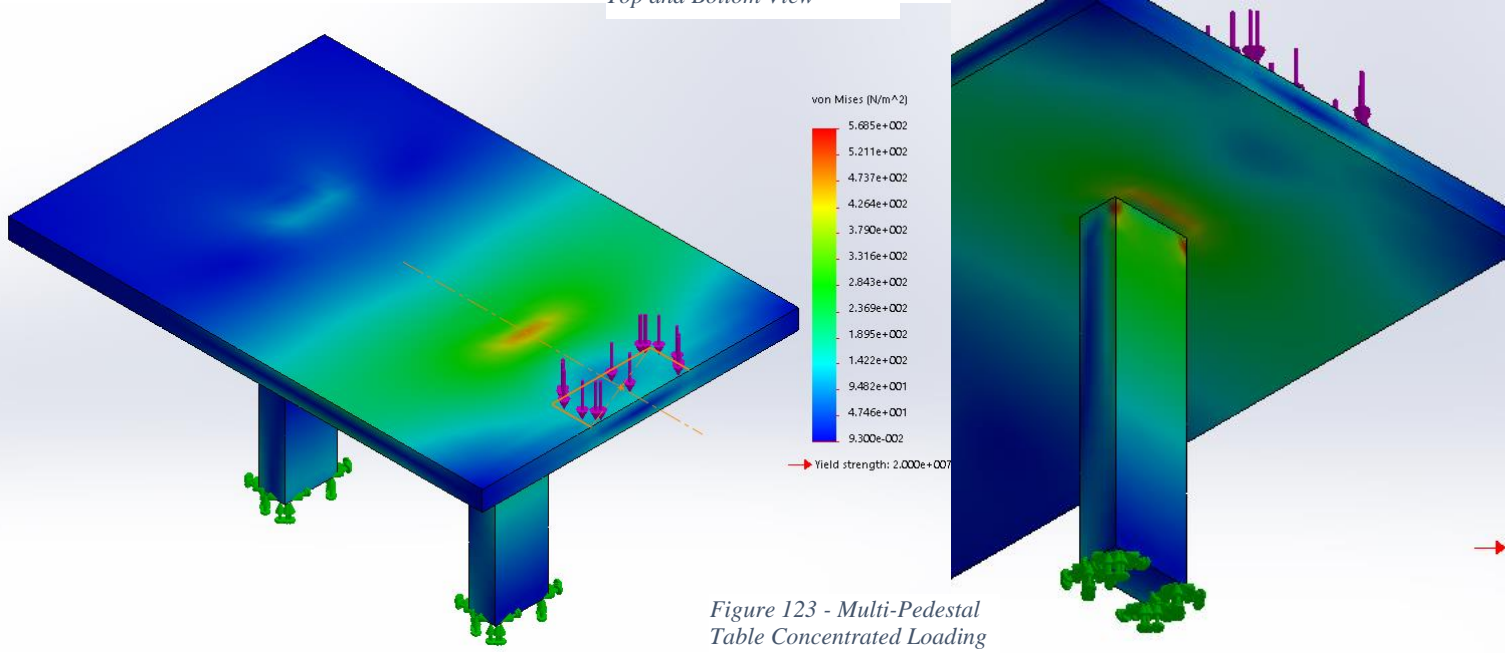

Figure 123 - Multi-Pedestal Table Concentrated Loading Top and Bottom View

APPENDIX B – DRAWINGS

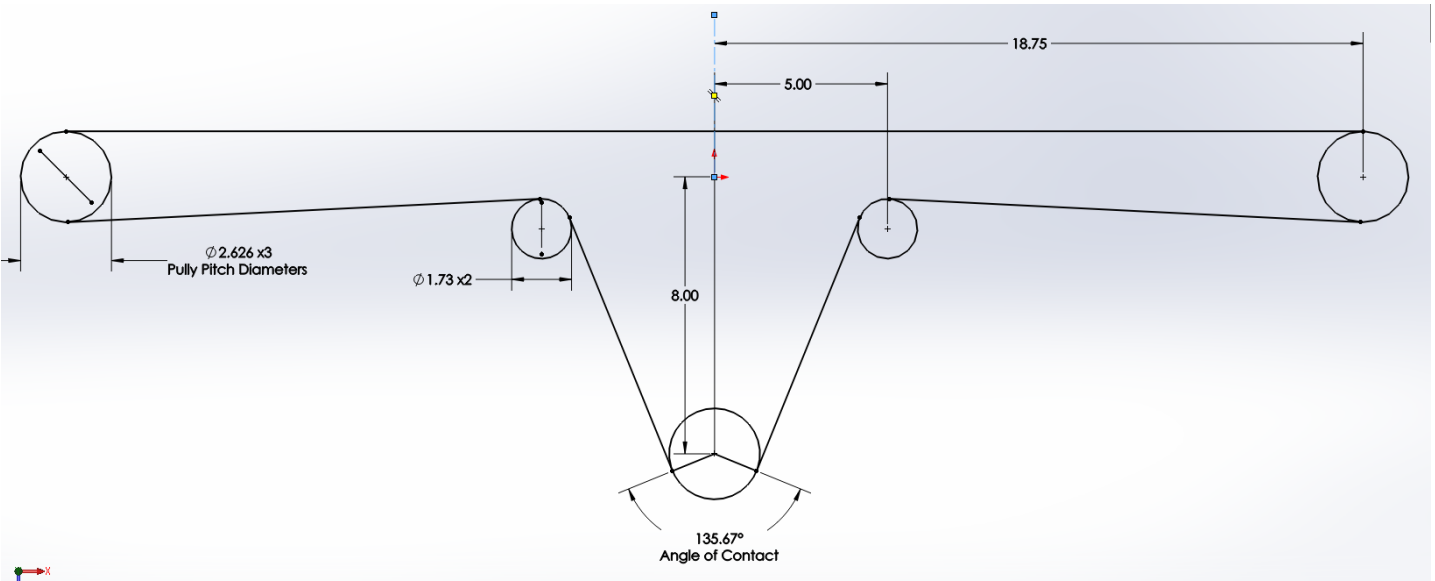

Figure 14 - Angle of Wrap Drawing for Pulley System.

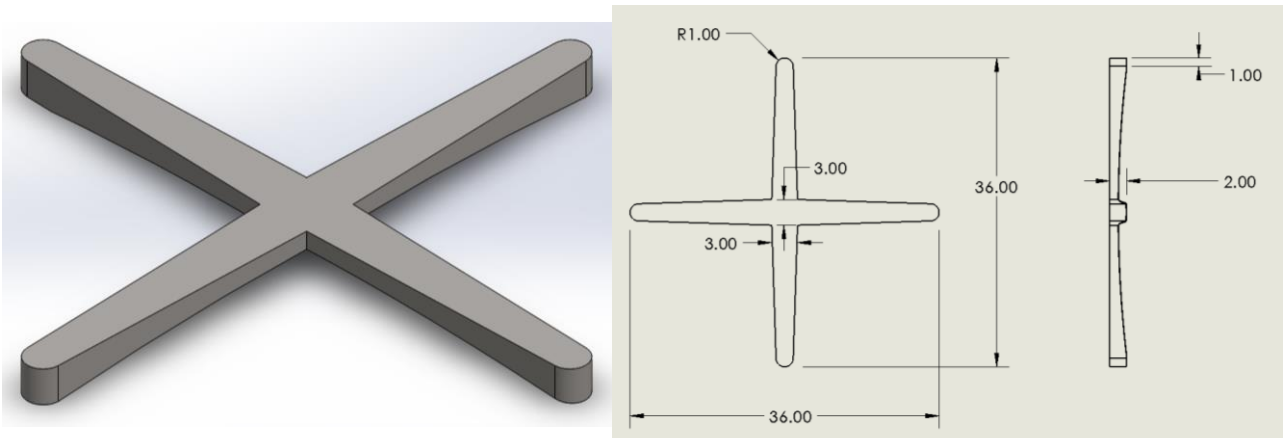

Figure 15 - Table leg mock model and dimensions

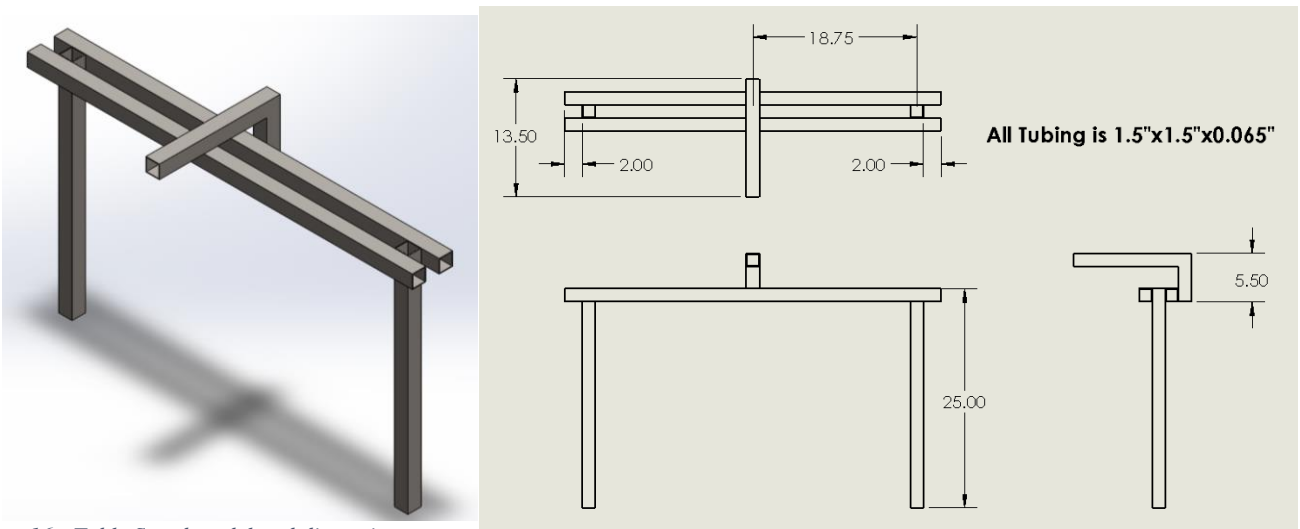

Figure 16 - Table Stand model and dimensions

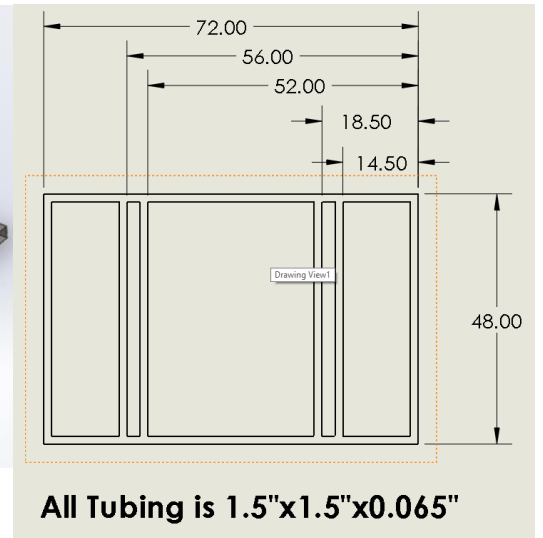
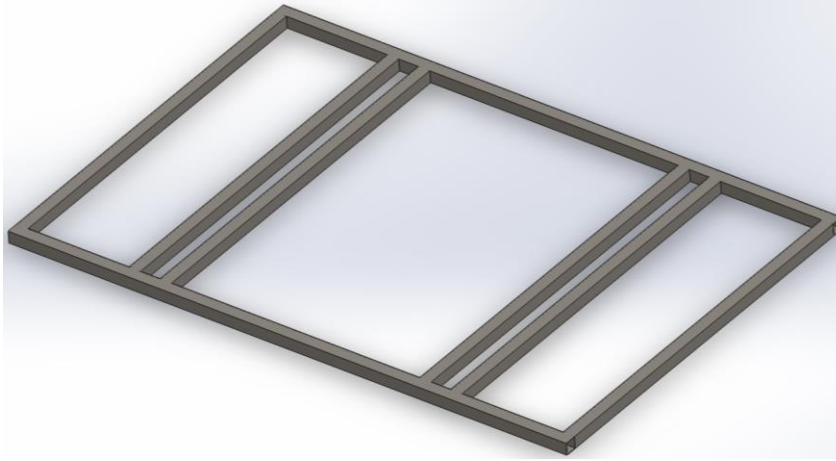

Figure 17 - Table Rest model and dimensions

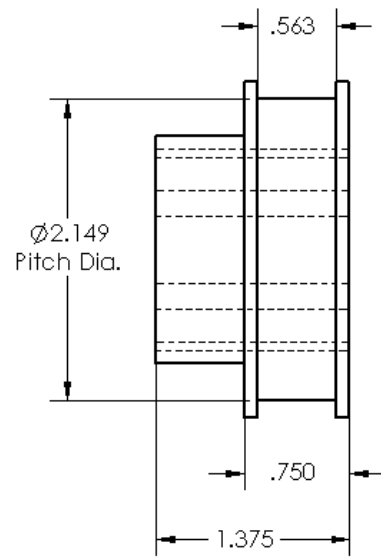
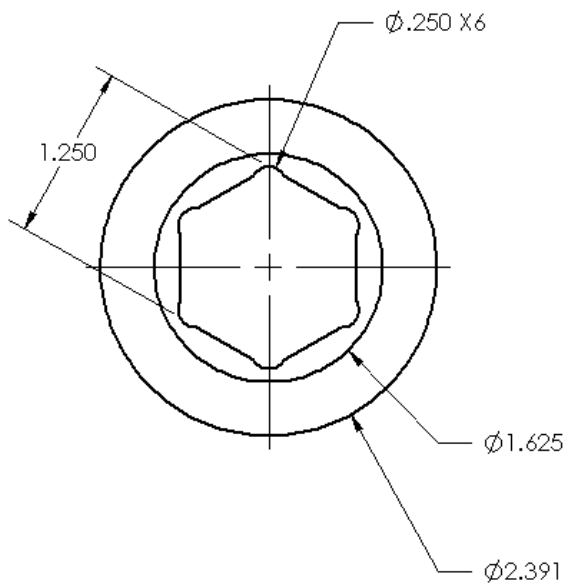
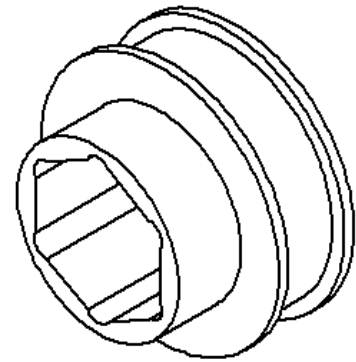

Figure 18 - Machined Pulley

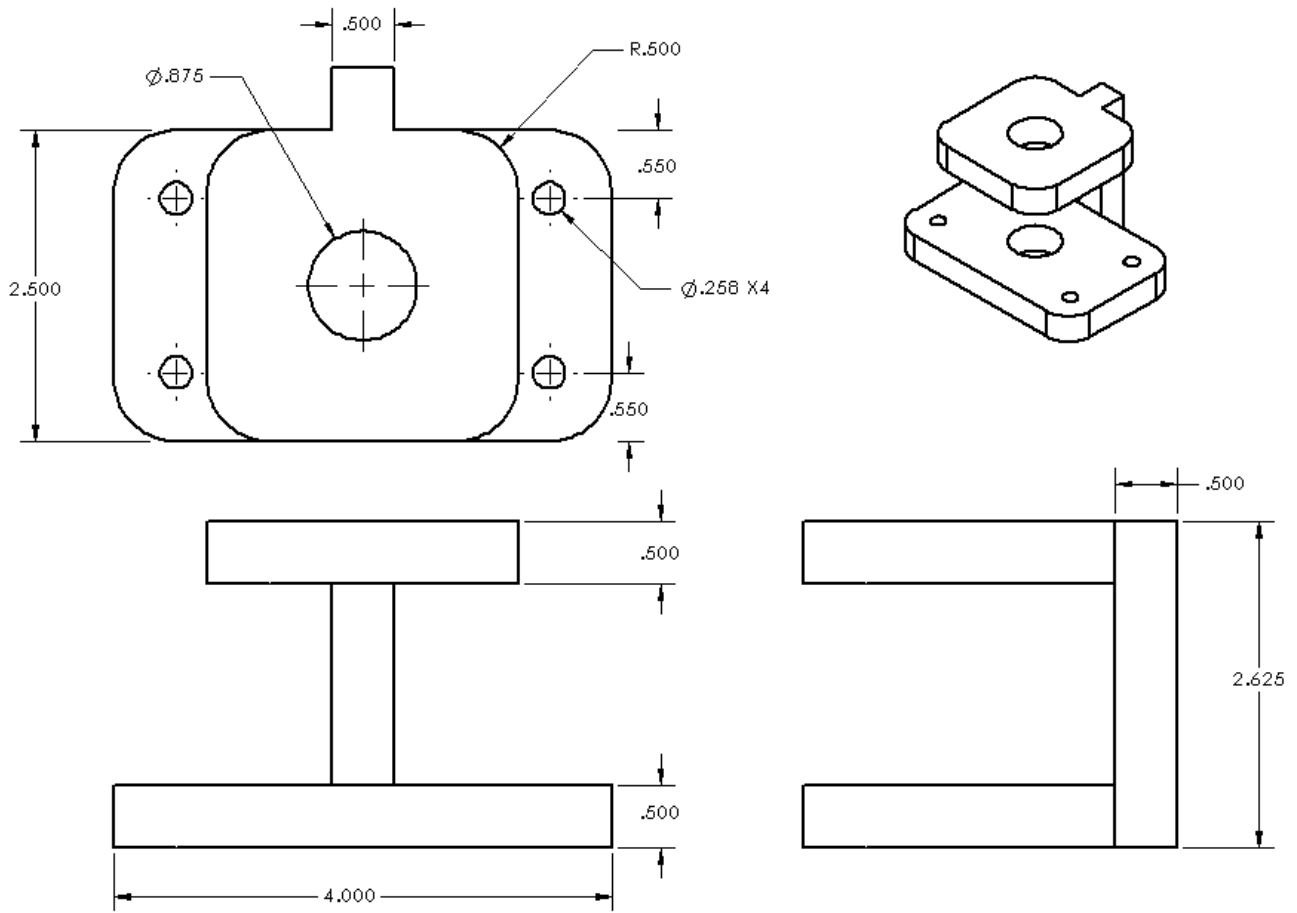

Figure 19 - Acme Thread Locator

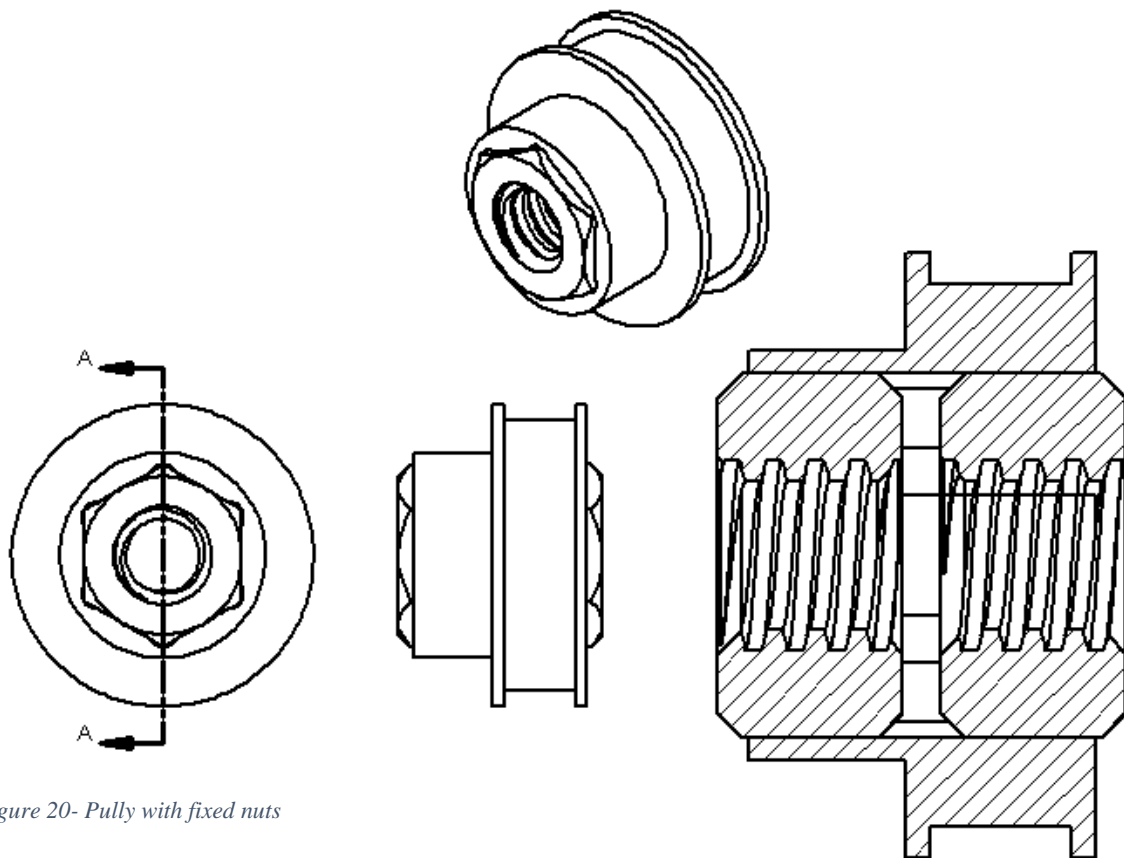

Figure 20- Pully with fixed nuts

SECTION A-A
SCALE 2 : 1

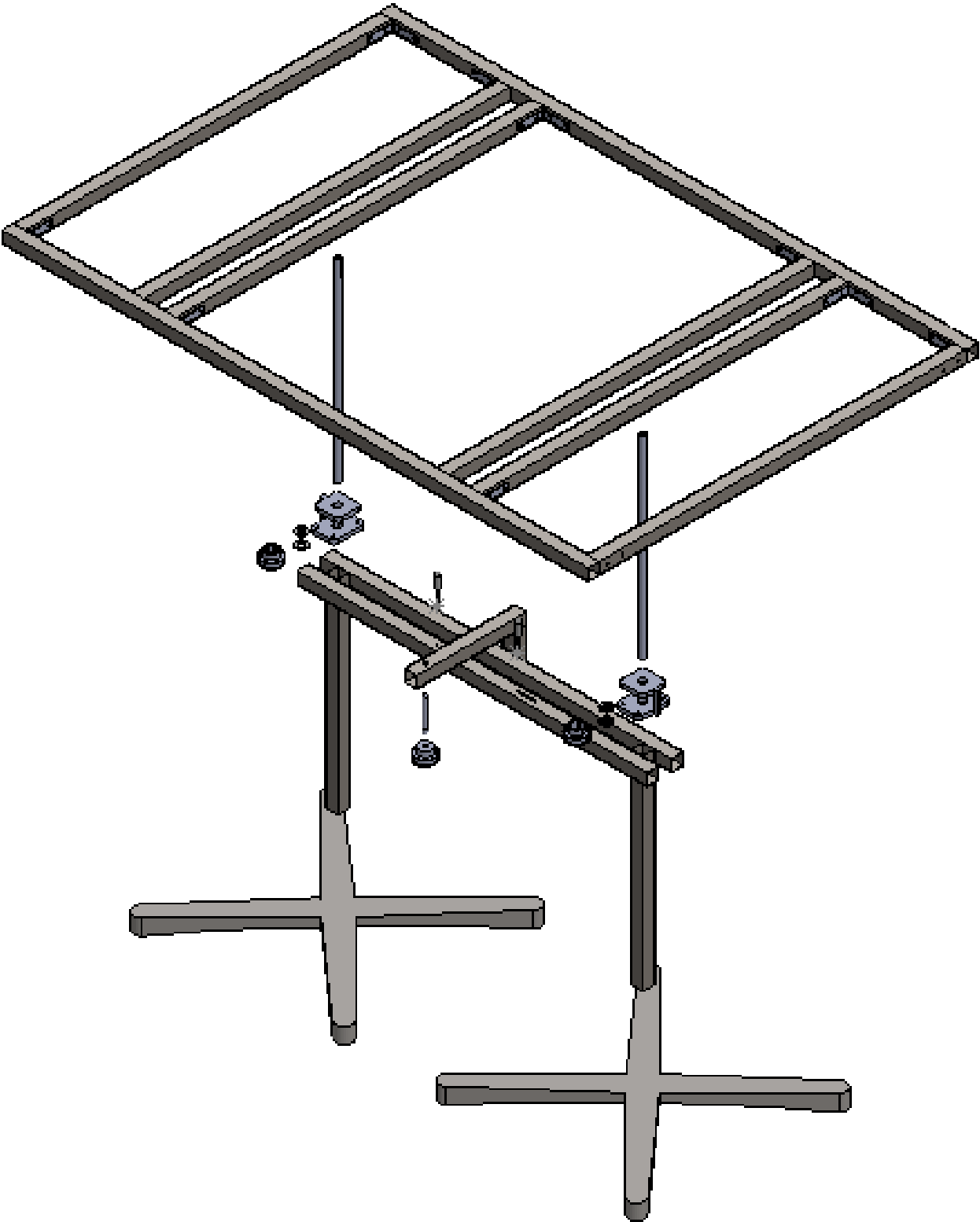

Figure 19 - Exploded View of Assembly

APPENDIX C – PARTS LIST

PART NAME	MODEL NUMBER	SOURCE	DIMENSIONS
Steel Square Tube	T111216	MetalsDepot	1 ½" x 1 ½" x 24' x 0.063"
Timing Belt Pulley	6495K15	McMaster Carr	
Timing Belt	6484K161	McMaster Carr	51" Outside Belt Length
ACME Threaded Rod	93410A140	McMaster Carr	¾ -5 ACME Size, 6ft length
ACME Threaded Bolt			
Housings	N/A	In House	½" Steel Plate
3 ½" Full Thread Nut	92240A556	McMaster Carr	¼-20, 3 ½"
2 ½" Partial Thread Nut	92198A552	McMaster Carr	¼-20, 2 ½"
Nylon Spacers	94638A283	McMaster Carr	1/2" OD, 1-7/16" Length, for 1/4" Screw Size
Nuts	N/A	In House	½-20
1 ½" Corner Brace	202033892	Ace Hardware	1 ½" x 1/2"
Welding Material	N/A	In House	N/A
Restaurant Table X-Base	XU-T3030-GG	Amazon	30"x30"
Retaining Rings	N/A	In House	½ Rod Rings

APPENDIX D – BUDGET

PART NAME	PRICE/UNIT	QUANTITY	TOTAL PRICE
Steel Square Tube	\$46.56	2	\$93.12
Timing Belt Pulley	\$26.66	3	\$79.98
Timing Belt	\$31.48	1	\$31.48
ACME Threaded Rod	\$77.24	1	\$77.24
ACME Threaded Bolt	\$4.53	4	\$18.12
Housings	In House	2	In House
3 ½" Nuts	\$4.33	1	\$4.33
2 ½" Nuts	\$5.31	1	\$5.31
Nylon Spacers	\$11.08	1	\$11.08
1 ½" Corner Brace	\$1.67	12	\$20.04
Welding Material	In House	N/A	In House
Table Base	\$51.53	2	\$103.06

Raw Materials: \$93.13
 Pre-Fabricated Parts:
 \$350.64
 Labor Costs: Donated
 Total Costs: \$443.67

While the original budget of \$300 was not met, the costs were determined mostly by the fact that the project had a lot of material that

was being used, and there was not really opportunity to cut cost, the steel square tubing that was used was already some of the thickest, and the timing belt components were as small as they could be given the loads.

APPENDIX E – SCHEDULE

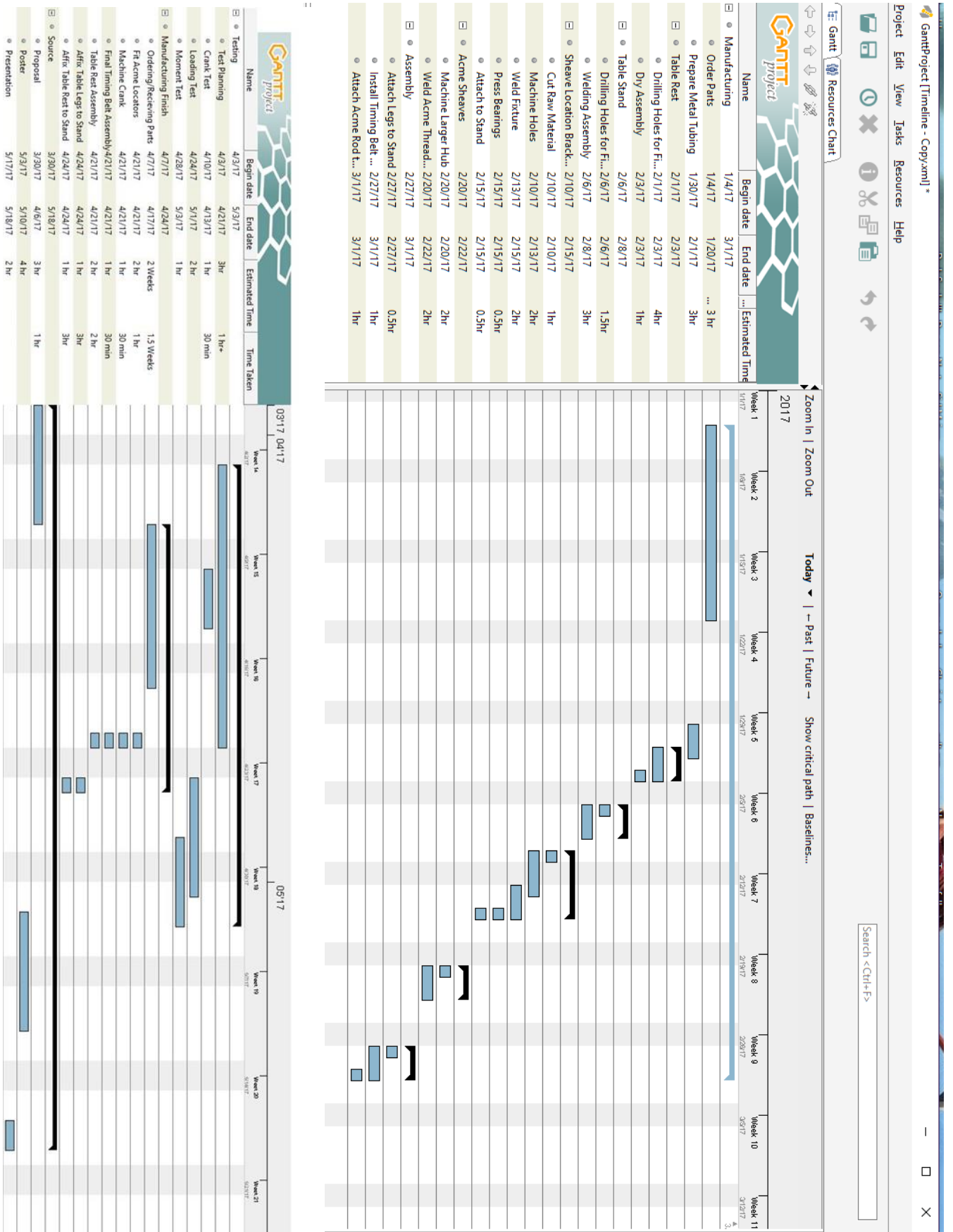

APPENDIX F – EXPERTISE AND RESOURCES

The only potentially extraordinary expertise and resources that are going to be needed come to the testing of the project, because it will need to be tested as an assembly instead of individual components larger or freestanding testing equipment could be necessary and having someone with the expertise to run those larger tests would be needed.

APPENDIX G – TESTING DATA

FORCE OF PULL DATA

Load (lb)	Trial 1	Trial 2	Trial 3	Trial 4	Average
0	1.5	1.8	1.8	1.4	1.625
20	10.6	9	10.6		10.06667
40	15.6	12.6	11.9	11.8	12.975
60	16.2	19	18.2		17.8

TIPPING MOMENT DATA

Area	Trial 1	Trial 2	Trial 3	Trial 4	Average
"Top" Side	75.2	76.5	75.8	79.3	76.7
"Bottom" Side	75.5	73.2	78.6	77.4	76.175

APPENDIX H – EVALUATION SHEET

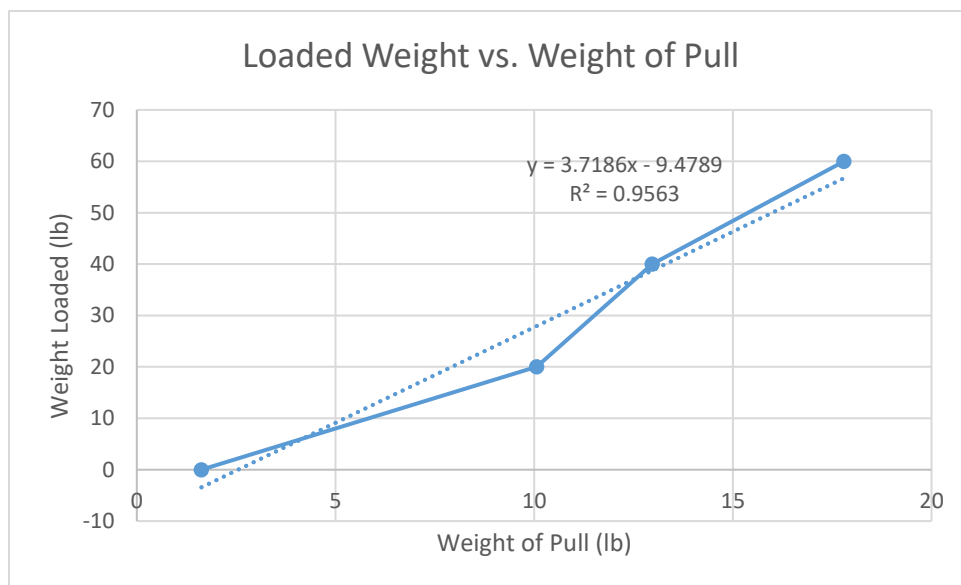

APPENDIX I – RESUME

Trevor Watkins

338 Sunset Dr., Oak Harbor WA, 98277 | C: (360)929-4724 | WatkinsTS@Live.com

Objective

To obtain an entry level job in a manufacturing or design field appropriate to mechanical engineering technology which will allow me to gain necessary skills and professional experience in an actual work environment in order to grow into a successful contributor of this career field.

Education and Certification

B.S., Mechanical Engineering Technology with focus in Manufacturing
Central Washington University, Ellensburg, WA, 98926
Anticipated completion December 2017

Associate of Arts, General Study
Edmond's Community College, Lynnwood, WA, 98036
Graduated 2014

Certified SOLIDWORKS Associate, 2016
Issued On: 06/08/2016
Certificate ID: C-9TSP7MLRP
Issued By: VirtualTester Online, Tangix Design & Development AB

Skills

-
- Manual Engine Lathe
 - Manual Milling Machine
 - Manual Horizontal Milling Machine
 - Rapid Prototyping
 - AutoCAD
 - Solidworks Modeling
 - Ability to read drawings/blueprints
 - Word Processing
 - Detail Oriented
 - Communication

Experience

-
- Sales Associate**, Walmart, Mount Vernon, WA
2013 - 2014
- Electronics sales
 - Garden and seasonal sales
 - Customer service including problem solving as to what products would work best for the customer's needs
 - Communicating with small team of other employees and managers
 - Completing assigned tasks with employee derived methods of work
 - Money handling with customer interfacing