

Transactions of the VŠB – Technical University of Ostrava, Mechanical Series
No. 2, 2015, vol. LXI
article No. 2003

Jakub E. TAKOSOGLU*, **Pawel A. LASKI****, **Slawomir BLASIAK*****

DESIGN OF THE MODULAR PNEUMATIC VALVE TERMINAL

NÁVRH MODULÁRNÍHO TERMINÁLU PNEUMATICKÝCH VENTILŮ

Abstract

The paper presents design of the modular pneumatic valve terminal, which was made on the basis of the patent application No A1 402905 „A valve for controlling fluid power drives, specially for pneumatic actuators, and the control system for fluid power drives valves”. The authors describe a method of operation of the system with double-acting valve and 5/2 (five ways and two position) valve. Functions of the valve, and an example of application of the valve terminal in the production process were presented. 3D solid models of all the components of the valve were made. The paper presents a complete 3D model of the valve in various configurations. Using CAD-embedded SOLIDWORKS Flow Simulation computational fluid dynamics CFD analysis was also carried out of compressed air flow in the ways of the valve elements.

Abstrakt

Příspěvek prezentuje návrh modulárního terminálu pneumatických ventilů, který byl proveden na základě patentové přihlášky č A1 402905 A ventilem je určen, pro řízení tekutinových elektrických pohonů, speciálně pro pneumatické pohony. Autoři popisují způsob provozu systému s dvojcestného ventilu a ventilu typu 5/2 (pět cest, a dvě polohy). Byly prezentovány funkce ventilu, a příklad použití terminálu ve výrobním procesu. Byly provedeny pevné 3D modely všech složek ventilu. Příspěvek prezentuje kompletní 3D model ventilu v různých konfiguracích. Pro výpočty a analýzu byl použit CAD-embedded SolidWorks Flow System, byla také provedena CFD analýza proudění stlačeného vzduchu v cestách ventilu.

Keywords

pneumatic valve terminal, directional valve, cylinder, 3D model, CAD, CFD

1 INTRODUCTION

In the pneumatics system, the most commonly used directional valves, which are designed to separate the air stream between the input and output ways of the valve [6, 7]. Such valves do not provide information about the position of the piston valve, and therefore of the switching the valve. Sometimes the valves are equipped with LEDs indicating the turn on control signal. The directional control valves are not able to fault diagnosis of the valve and the pneumatic actuator. Based on its

* Ph.D., Department of Mechatronics Devices, Faculty of Mechatronics and Mechanical Engineering, Kielce University of Technology, Aleja Tysiąclecia Państwa Polskiego 7, 25-314 Kielce, tel. (+48) 41 34 24 502, e-mail qba@tu.kielce.pl

** Ph.D., Department of Automation and Robotics, Faculty of Mechatronics and Mechanical Engineering, Kielce University of Technology, Aleja Tysiąclecia Państwa Polskiego 7, 25-314 Kielce, tel. (+48) 41 34 24 489, e-mail pawell@tu.kielce.pl

*** Ph.D., Department of Mechanical Technology and Metrology, Faculty of Mechatronics and Mechanical Engineering, Kielce University of Technology, Aleja Tysiąclecia Państwa Polskiego 7, 25-314 Kielce, tel. (+48) 41 34 24 756, e-mail sblasiak @tu.kielce.pl

own patent application No A1 402905 „A valve for controlling fluid power drives, specially for pneumatic actuators, and the control system for fluid power drives valves” the authors have developed a design of modular pneumatic valve terminal. Fig. 1 shows a diagram of the control system of a double acting pneumatic cylinder using one module [8].

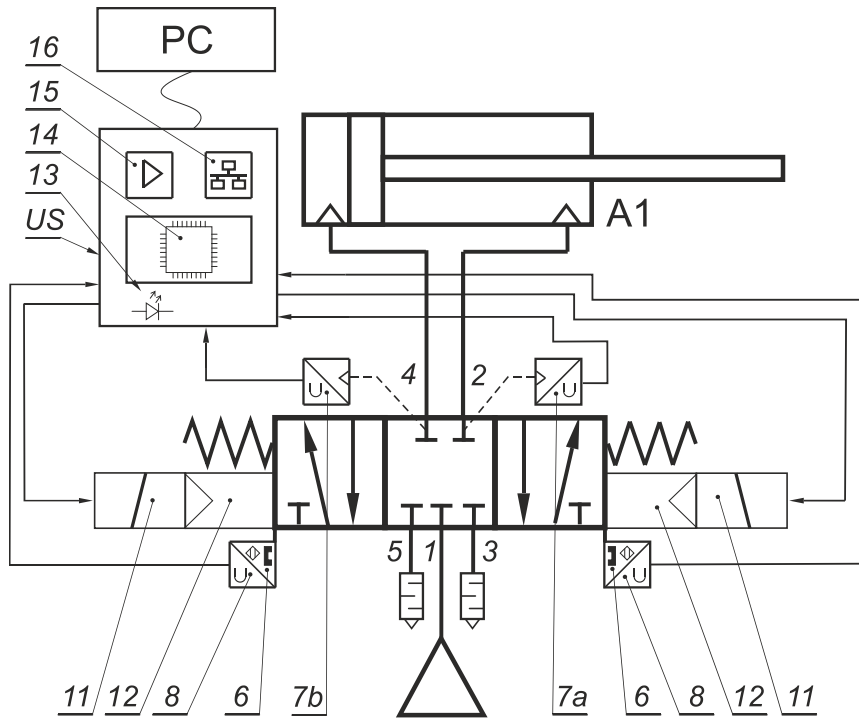

Fig 1 Diagram of the control system of the double acting pneumatic cylinder

The input and output ways of the valve was determined 1, 2, 3, 4, 5. In the output ways 2, 4 are pressure transducers 7a and 7b. The pressure sensors are connected to the AD transducer of the US control system. At the end of the piston valve are mounted permanent magnets, which interact with the magnetic field sensors 8. The magnetic sensors 8 detect the position of the permanent magnets 6. The valve is controlled by a two-stage electromagnetic transducers 11 and 12. Measurement and control system US, record the pressure and the magnetic field strength measurement data, and generates control signals. The system consists of the LEDs 13 signaling the module states, the microprocessor 14, the amplifier 15 and the communication network 16. In order to improve diagnostic functions, can be used fuzzy logic in the control system [7, 11].

2 PROTOTYPE OF VALVE TERMINAL

Fig. 2 shows a general view of the modular pneumatic valve terminal prototype made according to Patent Application No. A1 402905.

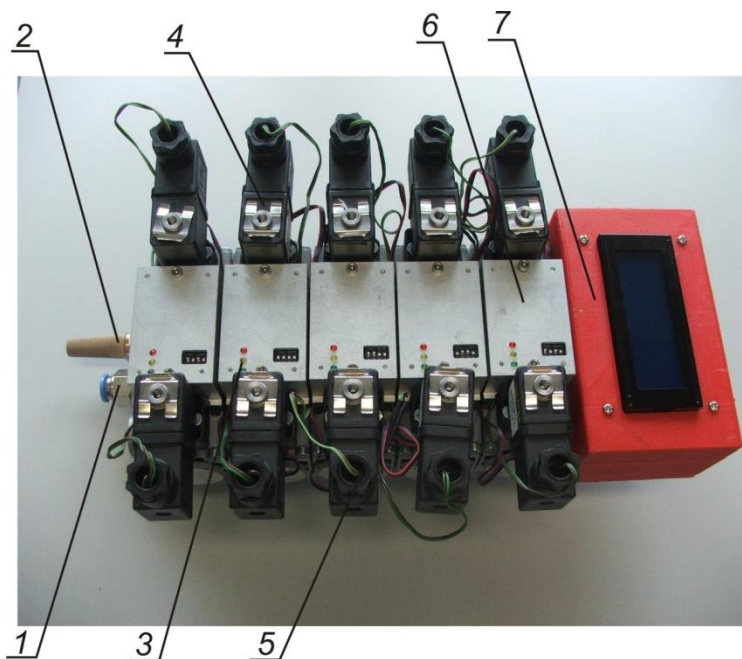

Fig 2 General view of the modular pneumatic valve terminal prototype: 1 - air supply, 2 - silencer, 3 - LED, 4 - coil, 5 - plug, 6 - valve module, 7 - control system

In order to present the possibilities of the valve terminal performed the experimental stand. The stand consists of four double acting cylinders controlled by the valve terminal. The actuators move the piston inside a square box. General view of the stand shown in Fig. 3.

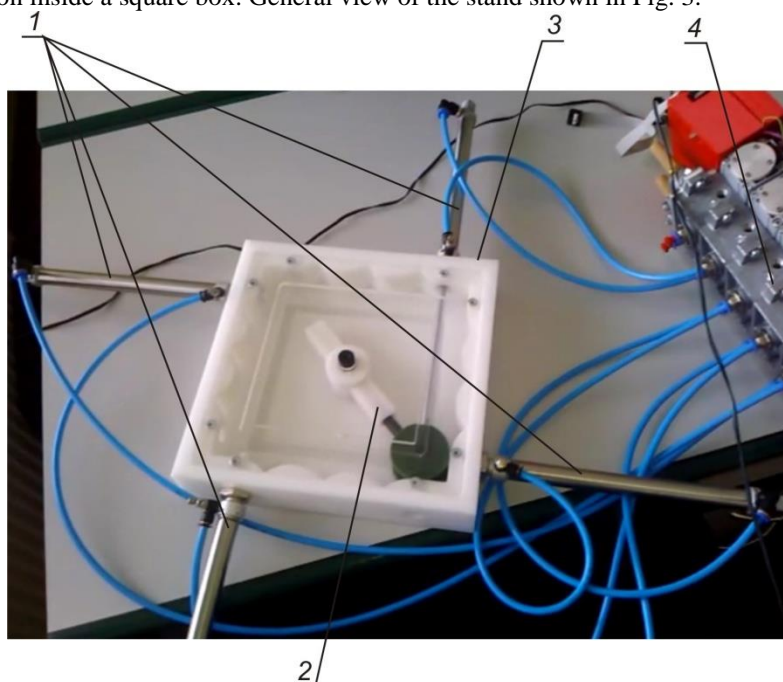

Fig 3 General view of the stand: 1 - pneumatic cylinders, 2 - piston, 3 - box, 4 - valve terminal

3 DESIGN OF NEW VALVE TERMINAL

Because the pneumatic valve terminal prototype are constructed with valves of the old type, Ośrodek Badawczo Rozwojowy Elementów i Układów Pneumatyki OBREiUP Sp. z o.o. [Ltd.], the authors developed a new design of the valve terminal. 3D modeling, the kinematic and dynamic analysis [3, 9, 10] were performed in SolidWorks software. Thanks to the 3D software, the mathematical model, the model of dynamics [2, 4, 5] are not necessary to solve the problem of moving parts of the valve terminal. Presented solid models (Fig 4) of the valve terminal are complete and contain all the necessary elements to perform the valve terminal. The authors have also developed a technology to made the valve terminal.



Fig 4 Solid models of the elements of the modular pneumatic valve terminal

Fig. 5 shows an isometric view of the valve 5/2, while Fig. 6 shows a view of the same valve in a translucent view mode.

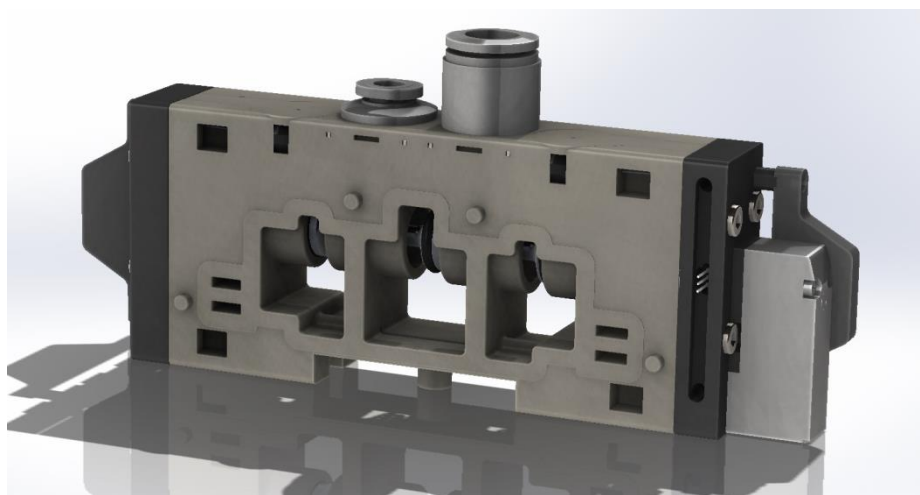

Fig 5 Solid model of the valve 5/2 module

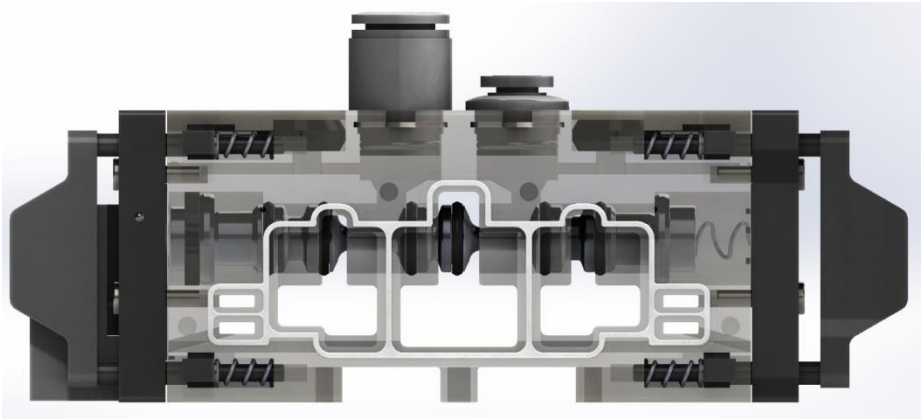

Fig 6 Solid model of the valve 5/2 module translucent view mode

Different submission of 3D elements allows to configure the valve terminal with different functions. Fig. 7 shows an isometric view of the valve terminal with air supply from one side.

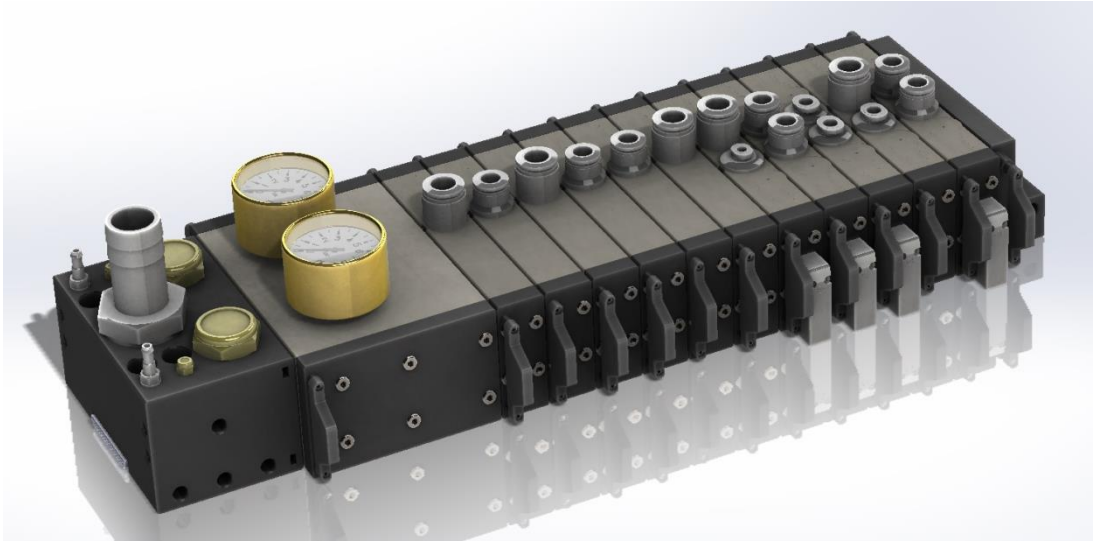

Fig 7 Solid model of the modular pneumatic valve terminal, air supply from one side

Fig. 8 shows an isometric view of the valve terminal with air supply from both side.

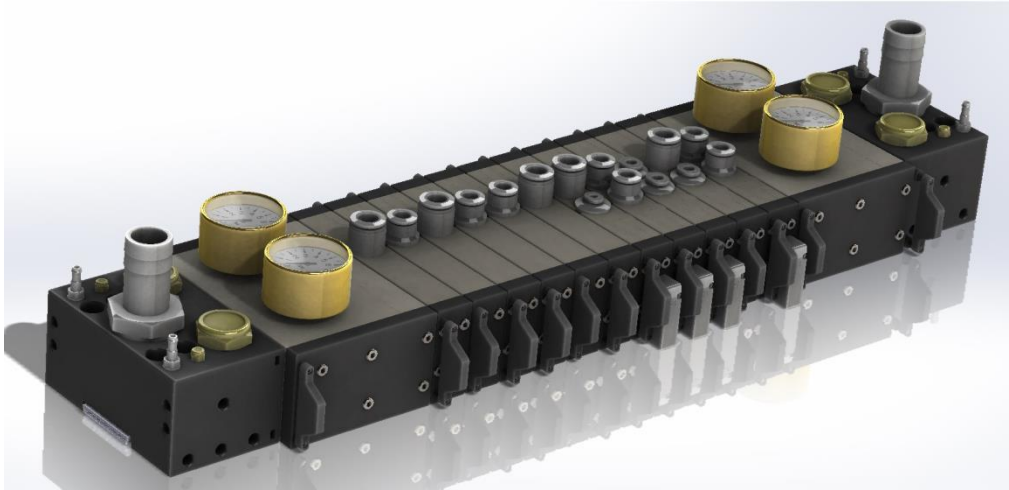

Fig 8 Solid model of the modular pneumatic valve terminal, air supply from both side

Fig. 9 shows a close-up on an air supply.



Fig 9 Solid model of the air supply

Fig. 10 shows the complete modular pneumatic valve terminal.

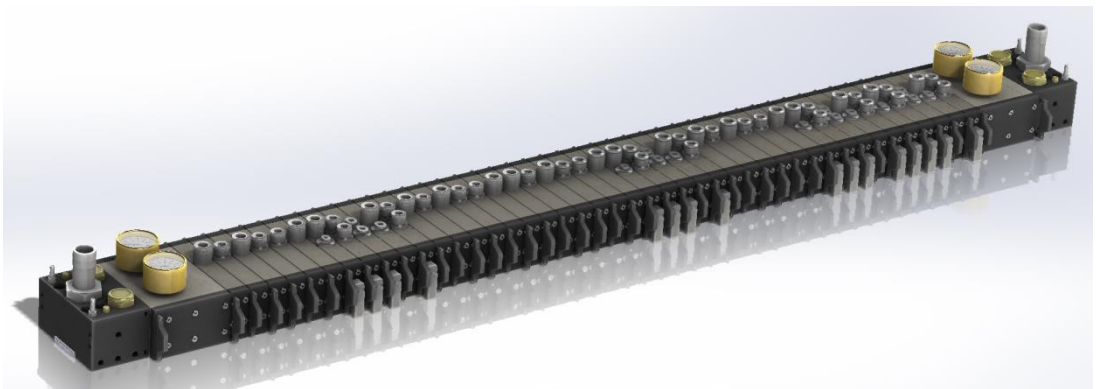

Fig 10 Solid model of the complete modular pneumatic valve terminal

5 CFD SIMULATION

The computational fluid dynamics CFD, is a branch of the fluid mechanics that uses the numerical methods and algorithms to solve and analyze a problems that involve fluid flows [1]. In the case of compressed air, which is a compressible fluid, may change the character of laminar flow to turbulent flow, velocity of the subsonic to supersonic, causing a change in the flow rights. Thanks to the numerical solution of the partial differential equations describing flow, it is possible to calculate an approximate speed, pressure, temperature distribution and other parameters. Modern CFD software possible to take account of viscosity and compressibility, multiphase flow, flow in which there flows the chemical reactions or combustion processes, flows through the porous structure and flow in which the medium is a Newtonian fluid or a non-Newtonian.

In the paper was conducted CFD simulation studies of the valve terminal in SOLIDWORKS Flow Simulation software. The paper presents selected results of the shut-off valve. Fig. 11 shows the distribution of the velocity vectors, and Fig. 12 shows the distribution of the pressure on the ways 1-2 at the maximum pressure drop.

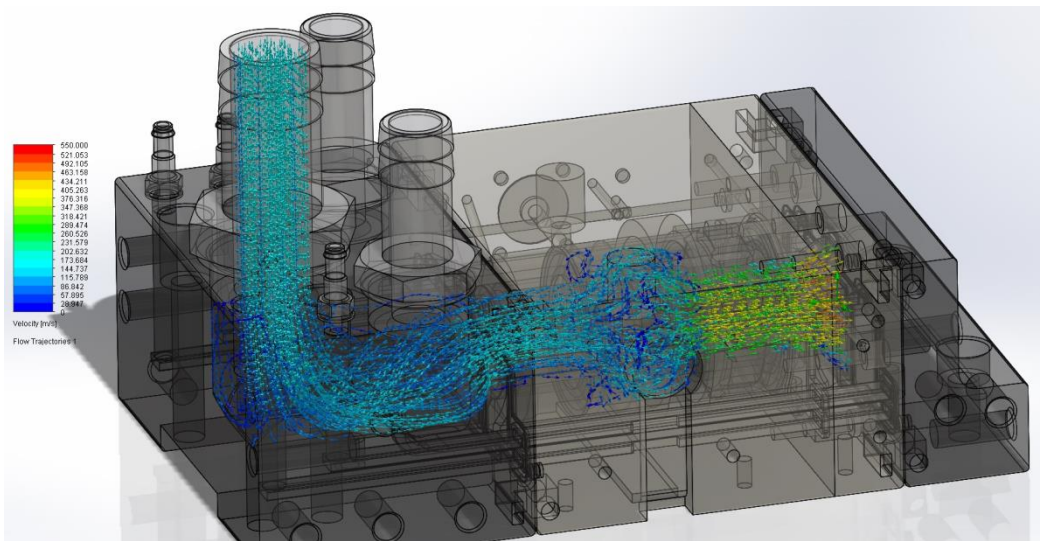

Fig 11 CFD simulation results of the distribution of the velocity vectors

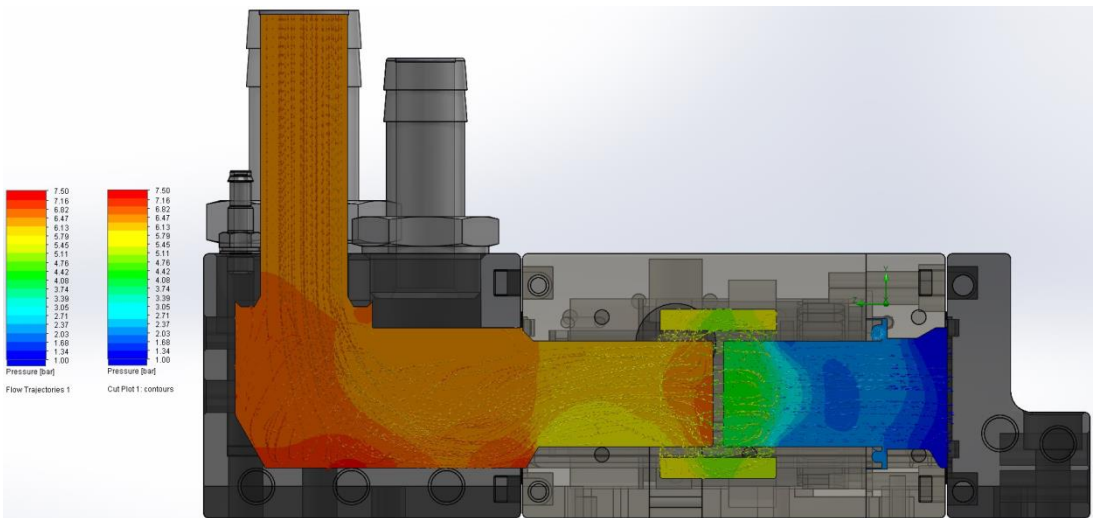

Fig 12 CFD simulation results of the distribution of the pressure at the maximum pressure drop

4 CONCLUSIONS

The paper presents the design of modular pneumatic valve terminal, which was made on the basis of the patent application No A1 402905 „A valve for controlling fluid power drives, specially for pneumatic actuators, and the control system for fluid power drives valves”. Shows the process of making a prototype device based on standard directional valves, and the process of designing a new modular pneumatic valve terminal. Designed pneumatic valve terminal provides:

Status checks of controls elements:

- confirmation of switching the valves,
- reading logic states of IO modules,
- parameters measurements of controlled elements.

Control of driving systems:

- switching the valves
- change the logic states.

Diagnostics of processes and valves:

- parameters checking,
- errors indication,
- valve diagnostics,
- diagnostics of selected states of the process.

Thanks to the CFD simulation research were analyzed the process of flow of compressed air through the components of the valve.

REFERENCES

- [1] Blasiak S., Laski P., Takosoglu J. Parametric analysis of heat transfer in non-contacting face seals, *International Journal of Heat and Mass Transfer*, Vol. 57, No. 1, 2013, pp. 22-31.
- [2] Gapinski D., Koruba Z., Krzysztofik I. The model of dynamics and control of modified optical scanning seeker in anti-aircraft rocket missile, *Mechanical Systems and Signal Processing*, Vol. 45, Issue 2, 2013, pp.433-447.
- [3] Huścio T., Siemieniako F. Modelling of the planar aerostatic two-coordinate relative bases, *Solid State Phenomena*, Vol. 198, 2013, pp. 372-377.
- [4] Krzysztofik I., Koruba Z. Mathematical Model of Movement of the Observation and Tracking Head of an Unmanned Aerial Vehicle Performing Ground Target Search and Tracking, *Journal of Applied Mathematics*, vol. 2014, Article ID 934250, 11 pages, 2014. doi:10.1155/2014/934250.
- [5] Krzysztofik I. The dynamics of the controlled observation and tracking head located on a moving vehicle. *Solid State Phenomena*, Vol. 180, 2012, pp.313-322.
- [6] Szenajch W. *Napęd i sterowanie pneumatyczne*. WNT, Warszawa 1997.
- [7] Takosoglu J. E., Laski P. A., Blasiak S. A fuzzy controller for the positioning control of an electro-pneumatic servo-drive. *Proceedings of the Institution of Mechanical Engineers Part I- Journal of Systems and Control Engineering*, Vol. 226, No. 10, 2012, pp. 1335-1343.
- [8] Takosoglu J.E., Laski P.A., Błasiak S. Innovative modular pneumatic valve terminal with self-diagnosis, control and network communications. *20th International Conference Engineering Mechanics 2014, Book of Full Texts*, Editor: Vladimír Fuis, Brno University of Technology, pp. 644-647, ISBN 978-80-214-4871-1.

- [9] Trochimczuk R. Conception of arm of medical robot dedicated to application of minimally invasive surgery, *Solid State Phenomena*, Vol. 198, 2013, pp. 3-8.
- [10] Trochimczuk R. Kinematic and dynamic analysis of new polar positioning system dedicated to mechatronic laser glass engraving system, *International Journal of Applied Mechanics and Engineering*, Vol. 19, No. 9, 2014, pp. 771-781.
- [11] Valasek R., Pavliska V., Perfilieva I., Farana R. Application of Fuzzy Transform for Noise Reduction in Helicopter Model, Edited by: Petras I., Podlubny I., Kacur J., Nawrocka A., Sapinski B., *Proceedings of the 2013 14th International Carpathian Control Conference (ICCC)*, 2013, pp. 400-405.