

ON-LINE EFFICIENCY IMPROVEMENT OF INDUCTION MOTOR VECTOR CONTROLLED

Djamel BENOUDJIT, Mohamed Said NAIT-SAID, Said DRID, Nasreddine NAIT-SAID

LSP-IE Laboratory, Electrical Engineering Department, Faculty of Technology, University of Batna 2, Rue Chahid Mohamed El-HadiBoukhrouf, 05000 Batna, Algeria

d_benoudjit@yahoo.fr, medsnait said@yahoo.fr, s_drid@yahoo.fr, n_nait said@yahoo.com

DOI: 10.15598/aeee.v14i3.1682

Abstract. Efficiency improvement is an important challenge for electric motor driven systems. For an induction motor, operation under rated conditions (at rated load with rated flux) is very efficient. However, in many situations, operation with rated flux causes low efficiency especially at light load ranges. In these applications, induction motor should operate at reduced flux which causes a balance between iron losses and copper losses leading to an improved efficiency. This paper concerns energy optimization, i.e. efficiency improvement is carried out via a controller designed on the basis of imposing the rated power factor, by finding a relationship between rotor flux and torque current component which can optimize the compromise between torque and efficiency in steady state as well as in transient state. Experimental results are presented to prove the effectiveness and validity of the proposed controller.

Keywords

Induction motor, power factor, Robust Optimizer Efficiency Factor (ROEF), vector control.

1. Introduction

Electrical motors consume more than 50 % of the electric energy used by the industry sector [1] and [2]. Applications utilizing induction motors include electric vehicles, water pumps, etc. These applications require different power levels and energy-efficient motor. Therefore, motor energy saving solutions using control techniques that maximize the motor efficiency are highly required [2] and [3].

One of the most important advantages of energy saving work is the ability to decrease power losses and electrical energy consumption.

Motor efficiency is defined as the ratio of mechanical output power to the electrical input power. It can be thus improved by reducing the electrical input power by means of minimizing the total losses.

To provide a high efficiency for electric drives it is necessary to find a system which may be optimal from the viewpoint of both engineering and economics.

Energy conservation and sufficient operation of a drive can be obtained, starting from the high quality of motor, inverter (improvement of its waveforms) and design, or by selecting an appropriate control method respecting the applied motor load. In the vector controlled method of induction motor, to get high dynamic performances, the flux is generally maintained at nominal value in order to give the maximum torque abilities of the machine especially at lower speed regime. But this fact decreases the motor efficiency especially at light load. To solve this problem, diverse methods and approaches have been developed in order to maximize the machine efficiency [2], [4], [5], [6], [7], [8], [9] and [10]. In these methods, the efficiency of induction motor drives under variable operating conditions can easily be improved by varying the flux level that guarantees loss minimization. At light load induction motor should operate at adapted and reduced flux, and for operation under rated conditions with rated load and rated speed the flux should be increased. However, it should be noted that the loss amount that can be reduced by adjusting the flux level significantly to the light load case more than at high load condition.

The efficiency optimization, for an induction motor lightly loaded, is realized by an optimum balance of the iron and copper losses. The algorithms are then developed by controlling different variables, such as rotor flux, power factor, etc. [10], [12] and [13].

Based on simple state control approach, this paper describes the experimental validation of an efficiency optimization controller for the vector controlled induction motor drives.

Efficiency improvement is carried out via an optimizer efficiency factor controller (ROEF) designed on the basis of setting the power factor equal to its rated value. In order to prove the validity of the proposed controller, the vector control scheme of the induction motor drive with and without the optimization algorithm is experimentally implemented using a digital signal processor board DS1103 for a laboratory 1.1 kW squirrel-cage Induction Motor (IM) vector controlled.

The paper is organized as follows. In Section 2, we briefly review the indirect rotor-flux-oriented control of induction motor drives. The proposed efficiency optimization approach is explained in Section 3. In Section 4, the experimental platform will be first presented. Some experimental results and their detailed discussions are then given. Conclusion is done in Section 5.

2. Vector Controlled Induction Motor

Field orientation is a technique that provides independent control of torque and flux, which is similar to a separately excited DC motor. The Park model of an induction motor can be represented according to the usual d-axis and q-axis components in synchronous rotating frame with:

$$\begin{cases} \bar{v}_s = (R_s + \sigma L_s \frac{d}{dt}) \bar{i}_s + \frac{d}{dt} \bar{\phi}_r + j\omega_s \sigma L_s \bar{i}_s \\ \quad + j\omega_s \bar{\phi}_r, \\ (1 - \sigma) L_s \bar{i}_s = (\frac{d}{dt} T_r + 1) \bar{\phi}_r + j\omega_{sl} \bar{\phi}_r, \end{cases} \quad (1)$$

where $\omega_{sl} = \omega_s - p\Omega$ is the slip frequency, ω_s is the synchronous angular speed, p is the number of pole pairs, Ω is mechanical rotor speed, \bar{v}_s is stator voltage vector ($v_{sd} + jv_{sq}$), \bar{i}_s is stator current vector ($i_{sd} + ji_{sq}$), $\bar{\phi}_r$ is rotor flux vector, R_s is the stator resistance, σ is the redefined leakage inductance, L_s is the stator inductance, T_r is the rotor constant time and j is imaginary unit, satisfying $j^2 = -1$). The developed torque is then:

$$T_e = p \frac{M}{L_r} \Im_m [\bar{i}_s] \cdot \bar{\phi}_r^*, \quad (2)$$

where M - is the mutual inductance, L_r - the rotor inductance. Orientation flux process is given by [14]:

$$\phi_{rq} = 0 \text{ and } \phi_{rd} = \phi_r. \quad (3)$$

Hence, the rotor flux can be controlled directly from the stator direct current component i_{sd} , while

the torque can be linearly controlled from the stator quadrature current component i_{sq} when the rotor flux is maintained constant. The basic formulations of field oriented control are:

$$\frac{\phi_r}{i_{sd}} = \frac{(1 - \sigma) L_s}{1 + T_r \cdot s}, \quad (4)$$

where $s = \frac{d}{dt}$: Laplace operator.

The slip frequency is given by:

$$\omega_{sl} = \frac{(1 - \sigma) L_s}{T_r} \cdot \frac{i_{sq}}{\phi_r}. \quad (5)$$

The rotor flux orientation angle can be derived from Eq. (5) as:

$$\theta_s = \int (\omega_{sl} + p\Omega) dt. \quad (6)$$

In many applications such as electric vehicle, the loads can be largely varied. From this point of view, the induction motor does not operate normally in field weakening region, thus the flux must be maintained constant to its rated value.

Consequently, once the flux ϕ_r is established to its rated value $\phi_r^* = M \cdot i_{sd}^*$ from i_{sd}^* - command in open loop control characterized by Eq. (3), the torque can be controlled linearly from i_{sq}^* - command such that:

$$T_e = p \frac{M}{L_r} \phi_r^* i_{sq}^*. \quad (7)$$

Considering the previous assumptions, the stator voltage equation can be written as:

$$\bar{v}_s = (R_s + \sigma L_s s) \bar{i}_s + \bar{e}_s, \quad (8)$$

where \bar{e}_s denotes the vector nonlinear coupling term given as:

$$\bar{e}_s = j\omega_s (\sigma L_s \bar{i}_s + \bar{\phi}_r^*). \quad (9)$$

The real time \bar{e}_s is compensation, from the feedback measured stator currents and the computed stator frequency, conducts to define a linear control between the component of stator current and its voltage, respectively. So, \bar{u}_s denotes the new stator voltage input from which we can define the following first order transfer function:

$$T(s) = \left(\frac{\bar{i}_s}{\bar{u}_s} \right) = \frac{T_o}{1 + \tau_{\sigma s} s}, \quad (10)$$

where $\bar{u}_s = \bar{v}_s - \bar{e}_s$, $T_o = \frac{1}{R_s}$ and $\tau_{\sigma s} = \frac{\sigma L_s}{R_s}$.

If real time \bar{e}_s - compensation is well realized, the bloc diagram of the linear and decoupled control of induction motor based in Indirect Field Oriented Control (IFOC) strategy can be stated as shown in Fig. 1.

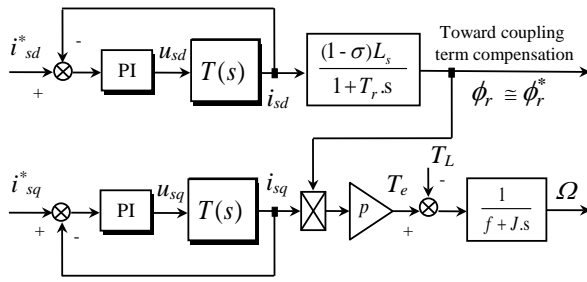

Fig. 1: Block diagram of the equivalent control of IFOC-IM.

The PI Proportional Integral controllers are useful to control the stator current components and are determined from the pole placement method.

Assume that the induction machine is magnetized before through the input command of the rated direct stator current i_{sd}^* as shown in Fig. 1.

Therefore, the rotor flux can reach its rated value ϕ_r^* when the direct stator current is rapidly controlled from the PI - controller, hence we can simply write $i_{sd} = i_{sd}^*$. In such a way, the torque control is completely and linearly referred to the quadrature stator current component. On the other hand, if the inner quadrature stator current closed loop is faster than the external speed one, we can write also $i_{sq} = i_{sq}^*$. By this manner, an open loop transfer function between i_{sq} - command and motor speed can be defined as:

$$G(s) = \frac{\Omega}{i_{sq}^*} \Big|_{T_L=0} = \frac{p\phi_r^*}{Js + f}. \tag{11}$$

3. Efficiency Optimization Approach

The best exploitation of an induction machine is when we can maintain a certain balance between active power generating electromagnetic torque and reactive power that products the flux. The simultaneous existence of these two powers is vital for an induction motor.

Figure 2 shows a simplified induction motor circle diagram, which is a graphical approach depicting the operation characteristics of an induction motor. Using this diagram, all the performance characteristics of an induction motor like power factor, efficiency etc. can be predicted.

As can be seen on Fig. 2, Ψ_o is the external load angle giving optimal power factor. This is obtained when the stator current vector becomes tangent to the circle, which carries out the optimality active-reactive.

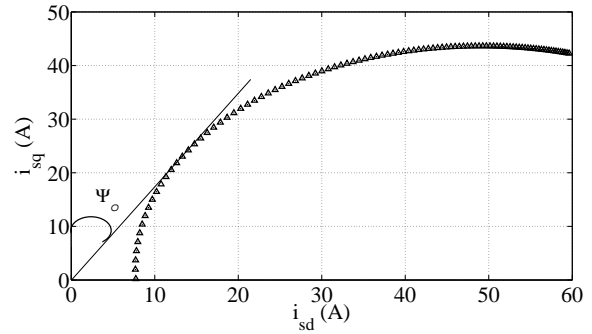

Fig. 2: Simplified circle diagram.

The reactive power Q can be written with stator voltage and stator current components by:

$$Q = v_{sd}i_{sq} - v_{sq}i_{sd}, \tag{12}$$

and the active power P as:

$$P = v_{sd}i_{sq} + v_{sq}i_{sd}. \tag{13}$$

The angle Ψ_o which constitutes the external load angle giving the optimal power factor is defined by the following relationship:

$$\tan(\Psi_o) = k_o = \frac{Q}{P} = \frac{\sin \Psi_o}{\cos \Psi_o} = \sqrt{\frac{1}{(\cos \Psi_o)^2} - 1}. \tag{14}$$

These obvious relations Eq. (11) and Eq. (12) lead to:

$$i_{sd} = \frac{1 - k_\alpha k_o}{k_\alpha + k_o} i_{sq}, \tag{15}$$

where $k_\alpha = \frac{v_{sq}}{v_{sd}} = \tan(\alpha)$.

The active-reactive optimization operation becomes simply:

$$i_{sd}^* = K_{ROEF} i_{sq}^*, \tag{16}$$

where * indicates input command variable.

The index (ROEF) means Robust Optimizer Efficiency Factor. The angle α is only given by the stator voltage components measurement.

One main advantage of the efficiency optimizer controller is that it is independent of machine parameter variations.

This efficiency controller in conjunction with the indirect vector control technique for induction motor drives has been employed in our configuration.

Figure 3 illustrates the particular characteristics of induction motor vector control describing by formulations Eq. (16), Eq. (17) and Eq. (18). Based on the

Tab. 1: Induction motor parameters.

Power	P_N	1.1	(kW)
Speed	n_N	1400	(rev·min ⁻¹)
Stator phase resistance	R_s	7.5	(Ω)
Rotor phase resistance	R_r	3.8	(Ω)
Mutual inductance	M	0.303	(H)
Stator inductance	L_s	0.3594	(H)
Rotor inductance	L_r	0.3032	(H)
Rotor inertia	J	0.0052	(kg·m ²)
Friction coefficient	f	0.0005	(Nm·s·rd ⁻¹)
Number of pole pairs	p	2	(-)

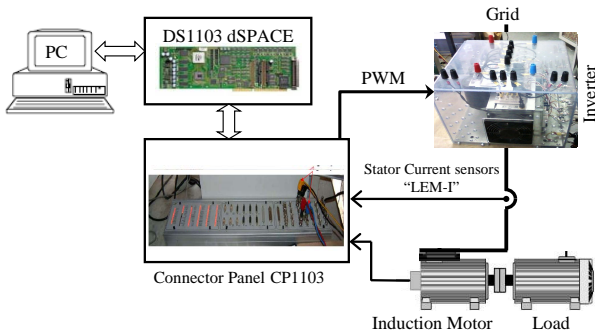

Fig. 5: Experimental setup.

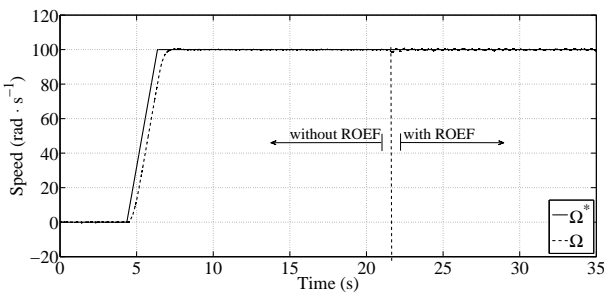

Fig. 6: Speed versus time.

As previously mentioned in Section 1. , it is known that efficiency improvement of induction motor drives can be realized via motor flux level.

This characteristic is demonstrated in Fig. 8 with and without the action of the efficiency optimization controller (ROEF). In these applications, induction motor should operate at reduced flux causes a balance between iron losses and copper losses, thereby improving the efficiency motor.

Consequently, as can be seen in Fig. 9, the terminal stator current is reduced and that the copper losses are decreased respectively to the flux component decreasing, which is represented by the stator current i_{sd} in Fig. 10.

It is also observed in this situation, the motor is operating with reduced flux level at light loads, which will certainly adapt and agree the torque output abilities.

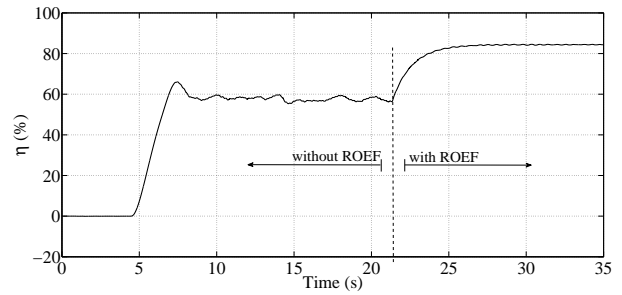

Fig. 7: Efficiency versus time.

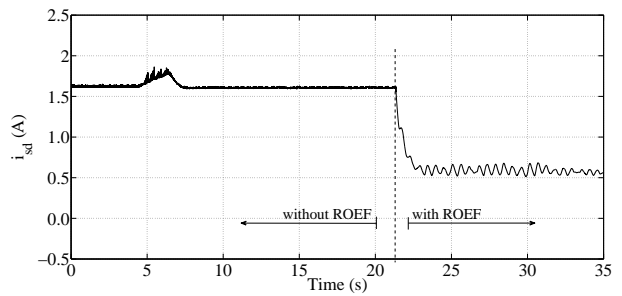

Fig. 8: Stator current direct component versus time.

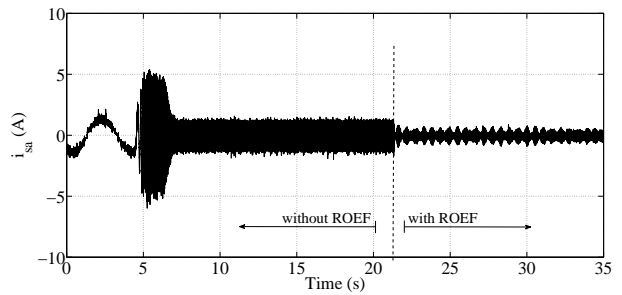

Fig. 9: Stator current versus time.

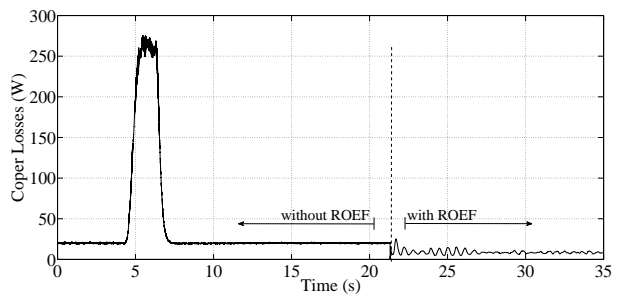

Fig. 10: Copper losses versus time.

This characteristic is well illustrated in Fig. 11 by the torque component current i_{sq} .

Finally, after various experimental tests, Fig. 12 shows comparison of motor efficiency evolution versus load torque T_L .

The results of this experiment demonstrate that when drive operates at light loads, the proposed algorithm (ROEF controller) enables important efficiency improvement (optimal efficiency) compared to the vec-

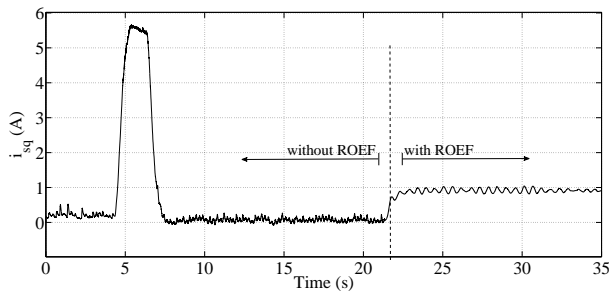

Fig. 11: Stator current quadrature component versus time.

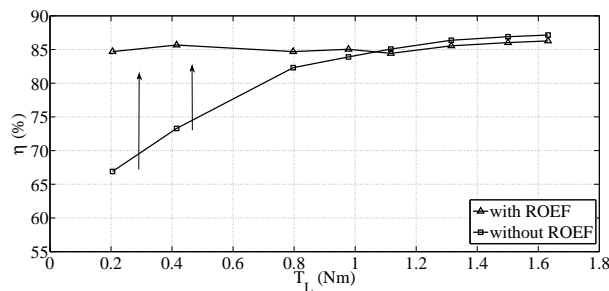

Fig. 12: Efficiency versus load torque.

tor control without ROEF. As an example, for a load torque of 0.2 Nm an increase in efficiency from 67.5 % to 84.5 % has been noticed.

The efficiency becomes smaller as the load torque increases. Indeed, for larger loads there is no efficiency improvement under the action of the proposed controller since the latter is only efficient at light loads.

This shows that the proposed controller (ROEF) is very suitable for the efficiency optimization of the induction motor drive, particularly at light load values. This will keep a certain balance between copper losses and iron losses, thereby a substantial power saving is achieved and the motor efficiency is consequently improved.

5. Conclusion

An efficiency optimization controller for the induction motor drives has been presented in this paper. The approach is simple and practical implementation is also easy. In addition, the main advantage of the proposed controller is that it is not related to the machine parameters. Experimental results confirm the validity and usefulness of the proposed controller, especially at light load values. In this sense, under the action of the proposed controller, any energy gain of some percent becomes significant and a substantial power saving is achieved and the efficiency of the drive is consequently improved.

References

- [1] CHAKRABORTY, C. and Y. HORI. Fast efficiency optimization techniques for the indirect vector-controlled induction motor drives. *IEEE Transactions on Industry Applications*. 2003, vol. 39, iss. 4, pp. 1070–1076. ISSN 0093-9994. DOI: 10.1109/TIA.2003.814550.
- [2] TA, C.-M. and Y. HORI. Convergence improvement of efficiency-optimization control of induction motor drives. *IEEE Transactions on Industry Applications*. 2001, vol. 37, iss. 6, pp. 1746–1753. ISSN 0093-9994. DOI: 10.1109/28.968187.
- [3] SAIDUR, R. A review on electrical motors energy use and energy savings. *IEEE Transactions on Industry Applications*. 2010, vol. 14, iss. 3, pp. 877–898. ISSN 1364-0321. DOI: 10.1016/j.rser.2009.10.018.
- [4] ABRAHAMSEN, F., F. BIAABJERG, K. PEDERSEN and P. B. THOEGERSEN. Efficiency-optimized control of medium-size induction motor drives. *IEEE Transactions on Industry Applications*. 2001, vol. 37, iss. 6, pp. 1761–1767. ISSN 0093-9994. DOI: 10.1109/28.968189.
- [5] LIM, S. and K. NAM. Loss-minimizing control scheme for induction motors. *IEEE Proceedings - Electric Power Applications*. 2004, vol. 151, iss. 4, pp. 385–397. ISSN 1350-2352. DOI: 10.1049/ip-epa:20040384.
- [6] VUKOSAVIC, S. N. and E. LEVI. Robust DSP-Based Efficiency Optimization of a Variable Speed Induction Motor Drive. *IEEE Transactions on Industrial Electronics*. 2003, vol. 50, iss. 3, pp. 560–570. ISSN 0278-0046. DOI: 10.1109/TIE.2003.812468.
- [7] SHUMA, C., L. CHEN and S. LIWEI. Study on efficiency calculation model of induction motors for electric vehicles. In: *Vehicle Power and Propulsion Conference*. Harbin: IEEE, 2008, pp. 1–5. ISBN 978-1-4244-1849-7. DOI: 10.1109/VPPC.2008.4677791.
- [8] LI, J., L. XU and Z. ZHANG. A New Efficiency Optimization Method on Vector Control of Induction Motors. In: *IEEE International Conference on Electric Machines and Drives*. San Antonio: IEEE, 2005, pp. 1995–2001. ISBN 0-7803-8987-5. DOI: 10.1109/IEMDC.2005.195993.
- [9] NAXIN, C., Z. CHENGHUI and Z. MIN. Optimal efficiency control of field-oriented induction

motor drive and rotor resistance adaptive identifying. In: *The 4th International Power Electronics and Motion Control Conference*. Xi'an: IEEE, 2004, pp. 414–419. ISBN 7-5605-1869-9.

- [10] VAEZ-ZADE, S. and F. HENDI. A continuous efficiency optimization controller for induction motor drives. *Energy Conversion and Management*. 2005, vol. 46, iss. 5, pp. 701–713. ISSN 0196-8904. DOI: 10.1016/j.enconman.2004.05.006.
- [11] SREEJETH, M., M. SINGH and P. KUMAR. Efficiency optimization of vector controlled induction motor drive. In: *38th Annual Conference on IEEE Industrial Electronics Society*. Montreal: IEEE, 2012, pp. 1758–1763. ISBN 978-1-4673-2420-5. DOI: 10.1109/IECON.2012.6388935.
- [12] QU, Z., M. RANTA, M. HINKKANEN and J. LUOMI. Structure property relationships in polyethylene/montmorillonite nanodielectrics. *IEEE Transactions on Industry Application*. 2012, vol. 48, iss. 3, pp. 952–961. ISSN 0093-9994. DOI: 10.1109/TIA.2012.2190818.
- [13] ABRAHAMSEN, F. *Energy Optimal Control of Induction Motor Drives*. 2nd ed. Aalborg: Institute of Energy Technology, Aalborg University, 2000. ISBN 87-89179-26-9.
- [14] XIAO-FENG, X., L. GUO-FENG and H. RONG-TAI. A rotor field oriented vector control system for electric traction application. In: *Proceedings of the 2000 IEEE International Symposium Industrial Electronics*. Cholula: IEEE, 2000, pp. 294–299. ISBN 0-7803-6606-9. DOI: 10.1109/ISIE.2000.930529.

About Authors

Djamel BENOUDJIT was born in Batna, Algeria. He received his M.Sc. and Ph.D. degrees in electrical engineering from the University of Batna, Algeria, in 2005 and 2010 respectively. His research interests include modelling and control of electrical drives, control system applications, and electric vehicles.

Mohamed-Said NAIT-SAID was born in Batna, Algeria. He received his M.Sc. in Electrical and Computer Engineering from the Electrical Engineering Institute of Constantine University, Algeria, in 1992. He received his Ph.D. degree in Electrical and Computer Engineering from the University of Batna in 1999. Currently, he is a Full Professor at the Electrical Engineering Department, University of Batna 2. His research interests include electric machines, drives control, and diagnosis.

Said DRID was born in Batna, Algeria. He received his M.Sc. and Ph.D. degrees in Electrical Engineering from the University of Batna, Algeria, in 2000 and 2005, respectively. Currently, he is a Full Professor at the Electrical Engineering Department, University of Batna 2, Algeria. His research interests include electric machines and drives, renewable energy, field theory and computational electromagnetism.

Nasreddine NAIT-SAID was born in Batna, Algeria. He received his M.Sc. degree in Industrial Electricity in 1993 and Ph.D. degree in electrical engineering from the University of Batna, Algeria in 2003. Currently, he is a Full Professor at the Electrical Engineering Department, University of Batna 2. His research interests include application of AI techniques and control in the field of electrical machines.