

VŠB - Technical University of Ostrava
Faculty of Electrical Engineering and Computer Science
Department of Cybernetics and Biomedical Engineering

Energy management in Smart Home
Management energií v Smart Home

Sandro Bekauri
Ostrava
2016

Diploma Thesis Assignment

Student: **Sandro Bekauri**
Study Programme: N2649 Electrical Engineering
Study Branch: 2601T004 Measurement and Control Engineering
Title: **Energy Management in Smart Home
Management energií v Smart Home**
The thesis language: **English**

Description:

Analysis of the potential for energy savings in Smart Home using comfort control of operational and technical functions in intelligent buildings with bus systems.

Objective:

Comparing of the options for energy saving in the Smart Home.

1. Perform a background research of the current state of the issue.
2. Compare the different types of technologies used in Smart Home(standards and legislative background), a detailed description of the chosen technology for energy management.
3. Proposal applications for energy management (draft of measurement methods used for analysis of measured data).
4. The practical realization.
5. Verification of results.
6. Overall evaluation of the results of the work.

References:

- [1] MERZ, Hermann, Thomas HANSEMANN a Christof HÜBNER. *Building Automation: Communication systems with EIB/KNX, LON and BACnet*. Springer Science & Business Media, 2009. 282 s. ISBN 3540888292.
- [2] HARPER, Richard. *Inside the smart home*. New York: Springer, c2003, xi, 264 p. ISBN 1-85233-688-9.
- [3] CLEMENTS-CROOME, Derek. *Intelligent buildings: design, management and operation*. Reston, VA: ASCE Press, distributor, 2004, xiv, 408 p. ISBN 0-7277-3266-8.
- [4] CELENEC. *SmartHouse Code of Practice*. Brussels:CENELEC, © 2005 CENELEC. CWA 50487.
- [5] Company literature KNX. Available from: <http://knx.org/knx-en/index.php>.

Extent and terms of a thesis are specified in directions for its elaboration that are opened to the public on the web sites of the faculty.

Supervisor: **Ing. Jan Vaňuš, Ph.D.**

Date of issue: 01.09.2015

Date of submission: 29.04.2016



doc. Ing. Jiří Koziolek, Ph.D.
Head of Department



prof. RNDr. Václav Snášel, CSc.
Dean of Faculty

Declaration

I declare that I have worked on this thesis independently, using only the primary and secondary sources listed in the references.

Ostrava 29.4.2016

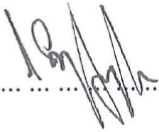

.....

Sandro Bekauri

Acknowledgment

At this point I would like to thank the head of my thesis Ing. Jan Vaňuš, Ph.D. for technical assistance, provision of resources and advices in processing work. Also I would like to express my gratitude to my colleague Tomáš Zbončák for laboratory assistance.

Abstract

This thesis aims to illuminate possibilities of increasing efficient energy use by creating visualization of measured energy consumption for end-user with respect to KNX technology. The motivation of creating system of KNX devices for monitoring and controlling energy consumption was reasons of increased demand of usage mobile devices and promotion of energy saving by visualization and using renewable energy.

In this thesis are described and considered several ways for energy management, first and the most important is visualization, as consumer is able to monitor and manage energy and electricity consumption via mobile device and PC that makes possible to motivate user for smart use of energy and set alarms of over limit energy consumption.

By the other hand remote control is flexible, comfortable and the idea that they can manage lighting and heating via mobiles attracts people. Mobile control is best solution to avoid paying extra money for buying touch panels.

Keywords

Smart Home, KNX technology, Energy management, SCADA, Mobile control, spaceLYnk.

Abstrakt

Tato diplomová práce si klade za cíl osvětlit možnosti zvýšení efektivního využití energie vytvořením vizualizace měření spotřeby energie pro koncového uživatele prostřednictvím KNX technologie. Motivací k vytvoření systému ze zařízení KNX pro monitorování a ovládání spotřeby energie bylo zvýšení poptávky použití mobilních zařízení a podpora úspory energie pomocí vizualizace a využití obnovitelných zdrojů energie.

V této diplomové práci je popsáno několik způsobů pro hospodaření s energií. První a nejvíce důležitá je vizualizace, takže je uživatel schopný monitorovat a řídit energii a spotřebu elektřiny prostřednictvím mobilního zařízení a počítače, což umožňuje jednak uživatele motivovat k inteligentnímu využití energie a také nastavit upozornění při nadměrné energetické spotřebě.

Dálkové ovládání je flexibilní, pohodlné, a díky možnostem nastavení osvětlení a topení prostřednictvím mobilu, také pro uživatele velmi atraktivní. Mobilní kontrola je nejlepším řešením pro vyhnutí se zbytečnému placení za nákup dotykových panelů.

Klíčová slova

Smart Home, KNX technologie, Management energií, SCADA, mobilní kontrola, spaceLynk

Contents

List of symbols and abbreviations.....	x
Figures content.....	xi
Tables Content	xiii
1. Introduction.....	1
2. Building control and automation.....	3
2.1. Smart Home	3
2.2. Building Energy Management Systems (BEMS)	4
2.3. Home energy management system (HEMS).....	5
2.4. Building automation and control systems (BACS).....	6
2.5. Intelligent home supervisory control system (IHSCS)	10
2.6. Supervisory Control and Data Acquisition (SCADA)	11
3. Energy Management	12
3.1. SCADA House Intelligent Management.....	12
3.2. Energy Management System using IEEE 802.15.4 and ZigBee.....	12
3.3. Energy Management Functions.....	13
3.4. Consumption of electricity in Czech Republic over the years.	16
4. Technologies used in smart home	18
4.1. Current Standards.....	18
4.2. BACnet	20
4.3. KNX.....	22
4.3.1. KNX protocol.....	22
4.3.2. KNX system components.....	25
4.3.3. The ETS concept.	27
4.4. LonWorks	29
5. Comfort, Convenience, and Functions in Room Automation.....	31
5.1. Room automation.....	31
5.2. Heating, Cooling, and Ventilation:	31
5.3. Lighting Control:.....	31
5.4. Blind and Shutter Control:	32
5.5. Security:	33
5.6. Multimedia:	33
6. Mobile laboratory project.....	34
6.1. Project design.....	34

Introduction.....	34
6.2. Lighting control.....	36
DALI gateway features	38
6.3. Blinds control.....	41
6.4. Comfort control.....	44
6.5. Energy management.....	46
KNX Energy meter features.....	46
Modbus energy metering Features	47
6.6. Remote control and supervision.....	50
6.7. Local control and monitoring.....	51
6.8. spaceLYnk	52
6.9. Wiring diagram of the switchgear.....	55
6.10. Floor plan with KNX sensors.....	55
6.11. KNX components overview.....	56
7. Visualization, Mobile control, SCADA.....	58
7.1. InSideControl.....	58
7.2. AyControl KNX.....	63
7.3. spaceLYnk visualization.....	65
7.4. Visualization	73
8. Smart Home scenario for energy saving.....	74
8.1. Scenario.....	74
9. Conclusion	75
10. References.....	76

List of symbols and abbreviations

HBES	Home and Building Electronic Systems.
HEMS	Home Energy Management System
BACS	Building Automation and Control Systems
BEMS	Building Energy Management Systems
BMS	Building Management System
AHEM	Automated Home Energy Management.
HAN	Home Area Network.
PCT	Programmable Communicating Thermostats.
IHSCS	Intelligent Home Supervisory Control System
SCADA	Supervisory Control And Data Acquisition.
SHIM	SCADA House Intelligent Management
HMI	Human Machine Interface.
DALI	Digital Addressable Lighting Interface
ETS	Engineering Tool Software.
EHS	European Home Systems.
PLC	Programmable Logic Controller.
BIM	Building Information Modelling

Figures content

Figure 1. Remote control of Smart Home.	4
Figure 2. Schematic overview of the HEMS. [5].....	5
Figure 3. DigiPoint. Direct Digital Controller (DDC)	8
Figure 4. MTN649908. Blind/switch actuator REG-K/8x/16x/10 with manual mode.	8
Figure 5. Network system in Building automation.	9
Figure 6. Structure of building control and automation Networks. [7].....	10
Figure 7. SCADA Home Intelligent Management.....	12
Figure 8. KNX Energy metering architecture.	14
Figure 9. Demand-Driven Setpoint Adjustment.	15
Figure 10. Monitoring Energy Consumption.	15
Figure 11. Presents the increased value of electricity consumption in Czech Republic.	16
Figure 12. Electricity consumption per capita (kWh per person)	17
Figure 13. Presents increased electricity demand by the inhabitants.	17
Figure 14. BACnet/IP internetwork	21
Figure 15. Twisted pair cable.....	22
Figure 16. Standard and KNX solution. [21]	24
Figure 17. System devices.....	25
Figure 18. Sensors.....	26
Figure 19. Actuators.....	26
Figure 20. Building parts.....	27
Figure 21. Group addresses.....	27
Figure 22. Manufacturer Products (Catalogue).....	28
Figure 23. Light control programing.....	28
Figure 24. LON DDC controller.	29
Figure 25. LON nodes in bus topology with terminators.....	30
Figure 26. Simple example of light switching and dimming control.....	32
Figure 27. Blinds, lights control with weather station in KNX.....	32
Figure 28. Lighting control.	36
Figure 29. Light control project with presence detector in ETS5.	37
Figure 30. DALI gateway connection.....	38
Figure 31. DALI ballast.	38
Figure 32. DALI commissioning 2 different ways. [28].....	39
Figure 33. DALI Plug-in.	39
Figure 34. View in Web address.	40
Figure 35. DALI IP address.	40
Figure 36. Blinds control.....	41
Figure 37. KNX weather station. ETS4 Blind control.	43
Figure 38. Blinds control project in ETS5.	43
Figure 39. Fan-coil control.....	44
Figure 40. Fan-coil control project in ETS5.	45
Figure 41. Merten Energy meter.	46
Figure 42. KNX energy meter parameters in ETS4.....	47
Figure 43. Metering gateway.	47
Figure 44. Energy meter. Modbus connection in ETS4.....	49

Figure 45. InSideControl, IP gateway.....	50
Figure 46. Touch Panel 7".....	51
Figure 47. spaceLYnk Standards and protocols compatibility.....	52
Figure 48. Mobile Laboratory with KNX devices.	54
Figure 49. Consumed energy by mobile LAB.	54
Figure 50. Wiring of switchgear.	55
Figure 51. Floor plan with sensors.....	55
Figure 52. KNX-IP InSideControl control scheme	58
Figure 53. InsSideControl Builder structure. [31].....	59
Figure 54. Energy monitoring project for smart phone in InSideControl Builder.	60
Figure 55. Room menu InSideControl Builder.	61
Figure 56. Device menu in InSideControl Builder.	61
Figure 57. Current energy consumption with InSideControl App.	62
Figure 58. Status query working. [31]	62
Figure 59. MTN680329, KNX/IP router.....	63
Figure 60. Lights and Blinds control in ayControl App.....	63
Figure 61. Blinds and lights control project in ayContol Editor.	64
Figure 62. IP address in Google Chrome.	65
Figure 63. Objects menu	66
Figure 64. Schedulers.....	66
Figure 65. Schedulers menu.....	66
Figure 66. Adding new Schedulers Events.	67
Figure 67. Adding new Scheduler holidays.	67
Figure 68. Trend logs.	68
Figure 69. Trend logs database.	68
Figure 70. Visualization home plan.	69
Figure 71. Light. Control according Lux. in ETS4.	69
Figure 72. Visualisation.	70
Figure 73. Layout.....	71
Figure 74. Energy monitoring (SCADA).....	71
Figure 75. Alarm indicators.	72
Figure 76. Current usage alarm in ETS4.....	72
Figure 77. Current real-time graph.....	72
Figure 78. InSideControl application example.	73

Tables Content

Table 1. Systems in building control.....	9
Table 2. Energy meters.	14
Table 3. Combinations of bits and signal elements.....	19
Table 4. BACnet objects.	21
Table 5. spaceLYnk communication ports.....	53
Table 6. KNX devices energy usage.	54
Table 7. Power supplies	56
Table 8. Actuators	56
Table 9. System devices	56
Table 10. Sensors	56

1. Introduction

The aim of this master's thesis is analysis of the potential for efficient energy consumption in Smart Home using comfort control of operational and technical functions in intelligent buildings with bus systems.

1. Perform a background research of the current state of the issue.
2. Compare the different types of technologies used in Smart Home (standards and legislative background), a detailed description of the chosen technology for energy management.
3. Proposal applications for energy management (draft of measurement methods used for analysis of measured data).
4. The practical realization.
5. Verification of results.
6. Overall evaluation of the results of the work.

The following steps have been solved and described in this paper:

Before choosing appropriate technology for my work, I had several options of technologies which are used in Smart Homes.

- BACnet.
- LON
- KNX

Firstly, after discussing for room level best solution is KNX and building management system should be done with BACnet technology.

By the other hand KNX advantages over LON at room level is KNX is a global standard, which products are already produced by more than 200 manufacturers. Each device of KNX is certified. Currently, there are over 2 500 such devices. Certification of devices is also a guarantee that the installation of KNX after long years of operation can be expanded at any time and legacy of devices can work without obstacles for years.

Due to the fact that KNX is an open system, can also be integrated with other communication protocols such as: BACNET, LON, Modbus, M-bus. Wide range of available KNX lighting control, blinds and comfort control.

In addition, older devices easily can be replaced by newer, if there is such necessity. There are KNX installations for lighting, blinds and solutions by manufacturer's that makes KNX priority technology for energy management project at room level.

Phases of energy management application realisation:

- I. I – Design
- II. II – Wiring
- III. IV - System configuration and programming device functions.

For programming KNX device functions is used ETS software, available on the KNX.org. Applications of the devices are available free of charge at the website www.schneider-electric.com.

The idea is to create flexible visualization for PC is used KNX device LSS100200 spaceLYnk. Right solution for connecting Modbus and KNX bus to SCADA via IP network. spaceLYnk is able to display measured electricity and monitoring of the consumption on a daily, monthly and yearly basis, as it has own memory.

Measured data, trend logs schedulers and lighting control are displayed simultaneously on PC after running IP address in Mozilla or Google Chrome.

For mobile device control two different application are used InSideControl builder for MTN6500-0113, KNX InSideControl IP-Gateway and ayControl application for MTN680329, KNX/IP router REG-K. Measured data and information about lighting and blinds are displayed on mobile device which is connected to KNX router network.

2. Building control and automation

2.1. Smart Home

Nowadays pervasive computing is gradually changing people daily lifestyle. The latest trend of computing, ubiquitous computing gives access to information and computing resources for inhabitants at anytime and anywhere. Since house is the place where everyone lives, smart home goal is to provide the best services to home users. In this environment, applications should be self-adaptive to the environment within which they operate.

A smart home is defined as an intelligent place which is able to gain and apply knowledge about its users and their surroundings in order to adapt and meet the goals of comfort and efficiency. Smart home has the characteristics of distributive, different, independence and cooperation.

Smart home may be determined as a well-designed structure with sufficient access to controls, data, assets, communication, and information technologies for enhancing the inhabitant's quality of lifestyle through comfort, convenience, low costs, and high level connectivity. The idea has been widely acknowledged for decades, but few people had ever seen a smart home, and less still have lived in one. A commonly cited reason for this slow increase has been the high cost associated with upgrading existing building to include "smart" technologies such as network connected appliances. However, users have historically been willing to reduce costs significantly for new communication technologies, such as mobile telephones, broadband internet connections, and television services. [1]

Smart home technology aims to improve the comfortable of living. On the other hand, smart home system allows inhabitant to control their house remotely and it provides security to the consumer as well as the building. According the information gathered via the sensors or appliances that can collect details of the environment, smart home can define the information and perform necessary actions based on the instructions or settings set before by the inhabitant. Nowadays, smart home technologies have rapidly grown into large number of production of smart home ready appliances.

There are a lot of different type of smart home appliances existed and they are designed based on different specific services required. Most of the intelligent appliances have different architecture and platform. Therefore, there could be some difficulties to interconnect and assemble information of different smart home appliances in a single home. There are thousands of research works related to centralization management control of smart home done by scientists. So, the proposed research is emphasis on reinforcing the higher level decision making of the smart home intelligent system. [2]

Service providers

They primarily are responsible for maintain appliances' information, such as control instructions function menus. Control instructions are gathered in corresponding manufacturer servers. Consumers get the control instructions and services from service providers through identifier resolution. The service demand or control instruction is divided into two types to complete.

- First, the client calls the resolver to complete resolution services and obtains the address of corresponding servers.
- Second, the client gets the services by sending service request packet or control instruction word to the servers.

User

They are the direct consumers of smart home services, they can monitor and control smart appliances, get the relevant services by the client. The client can accomplish the control of equipment through the interaction by the gateway. The related service information use identifier as an index and stored in the

corresponding servers and registered with the RNS platform. Users can get the address of information server by identifier resolution, and then get the function menu and control instruction to control appliances. [3]

What's the benefit of Smart Home?

A smart home is fully connected home. Turning your home into a smart home gives you a large amount of possibilities to access the Internet from anywhere in your house, remotely control your home with using smart phones. You can control with smart phone the surveillance camera, rooms lighting, temperature level in house and condition of smart home appliances whether it is turned on or off. Smart home can act according the weather changing by using weather stations, it can close or open blinds, turn down or up the heater. Reduce consumption of lights in sunny weather.

You can monitor your children behaviours and guarantee their safety. By the way you can find out how many people are in your smart home.



Figure 1. Remote control of Smart Home.

2.2. Building Energy Management Systems (BEMS)

The IEA (1997) uses the following description for a BEMS: "an electrical control and monitoring system that has the ability to control monitoring points and an operator terminal. The system can have attributes from all aspects of building control and management functions such as ventilation heating, and air conditioning (HVAC) for lighting, and energy management. Another most known description is that BEMSs are control systems for individual buildings or groups of buildings that use computers and distributed microprocessors for control and monitoring, storage data and communication. Also terms mostly used for this technology are Building Management System (BMS) and Energy Management System (EMS).

While all buildings demand and have some form of control system, BEMS technology is totally different from past control systems. The main point in which a BEMS is different from other control systems is the characteristic of communication: information of the functions and processes of the building can be received and controlled at a central, single operating unit. Therefore, decisions can be made based upon the received information (IEA, 1997). This is an important aspect of a BEMS as it allows for optimization of the system. For example, the single and central operating device can receive information of temperature and information when building is occupied and make the decision to

decrease the temperature in some parts of the building that are not occupied. That decisions, therefore can increase energy efficiency.

The IPCC (2007) notes that commissioning is a main stage in the implementation of the BEMS. Commissioning is the quality control process that starts with the early stages of design. On the other hand, it is essential to consider the BEMS technology and its required functions in the very first stages of design to optimize the operation potential and there-fore the energy savings of the technology. Basically, it could be more practical to incorporate a BEMS into the design of the building compared to older BEMS into an existing building. For instance, considering BEMS functions such as vertical transportation management in the design of the building, is much more practical as all essential electronics and wiring can be incorporated in the design. [4]

2.3. Home energy management system (HEMS)

HEMS stands for Home Energy Management System. This system is used to manage energy use in homes. It displays and calculates power generation and storage along with energy consumption by usage such as lighting, HVAC and home appliances in homes in every minute or hourly basis, and reports or advises on power consumption. Besides, in cases where power consumption is likely to exceed the present limit, the system controls the overall energy consumption by decreasing the air conditioning temperature settings or switching off low-priority appliances.

For energy conservation, smart houses can be equipped with a solar power generators, a windmill power generators, intelligent appliances which can be controlled by power line communication, and a smart meters. Every several minutes the smart meter would provide reports about power consumption through an energy service portal via a broadband Internet network connection and, later this information will be available online through a Web interface. The HEMS relies on the power consumption history to control appliances later. (Figure 2)

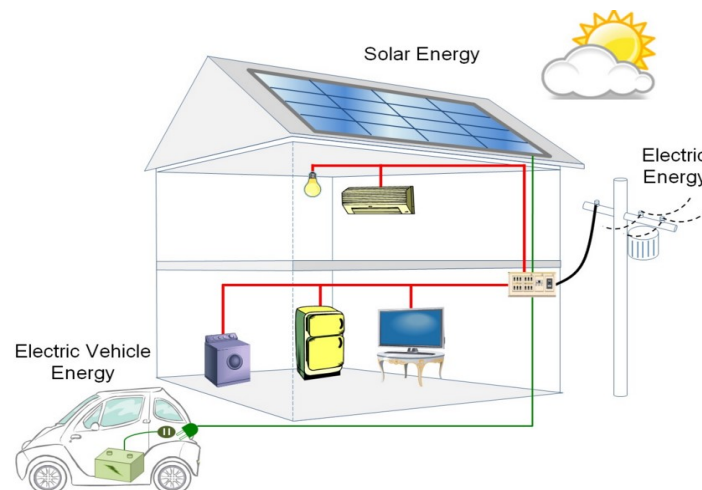

Figure 2. Schematic overview of the HEMS. [5]

The HEMS has the following 4 functions:

1. Auto-configuration: it is the most important function for customers of home network services because lot of homes have a wrong configuration.
2. Easy monitoring: stands for comfort and easy access to real-time information on energy consumption and helps the user pay attention to energy saving.

3. Remote control: online access to a customer's used energy and status of device enables appliances to be controlled remotely.
4. Smart planning: the automatic peak load management provides smart planning for reducing energy usage.

For energy management, it's considered 3 major concepts in HEMS.

- 1) **Smart planning.** The HEMS is based on real-time price-responsive load management concepts. Since, the APCPE understands the cost policy and the shift controlling appliances in peak load period. For that work, the APCPE (advanced power control planning engine) uses all kinds of relevant information (even weather forecasts) to control home appliances, for example solar panel or windmill power generators.
- 2) **Plausible controlling.** To prevent a peak load overflow, it's prepared two control system for intelligent device control and group managing. The plausible appliance control is a kind of control method customized for specific devices. Although unique control programs are embedded in each device, device system can define some efficient knowledge about the energy usage rate of a device via an external examination. The HEMS then controls the device with an optimized device control algorithm.
- 3) **Group management** — specifically for overall management of a group of devices. In electric load management, the peak consumption management is important. Through group management, for instance, the HEMS can switch off the outer fan of an air- conditioner for 5 to 10 minutes without noticing the user. [6]

2.4. Building automation and control systems (BACS)

Home and building automation systems are in the broadest sense of Concerned with Improving relation with and between devices typically found in an indoor user. Mostly, they provide a topic with many range and facets from small networks with only a handful of devices is a very large installations with lots of devices.

The level of automation in commercial and residential buildings has raised over the years. The reason of increased requirement is not just more convenience and comfort, but also the benefits that building automation brings with regard saving and energy management.

Supervisory Control and Data Acquisition (SCADA) systems for the buildings, it's referred as the central control and monitoring systems (CCMS), have been introduced. They extended the operator's access from having to handle each piece of home appliances locally over a whole buildings or complex, allowing the detection of unusual conditions without being on site. Despite environmental parameters, dry conditions include technical alarms indicating the need for maintenance and repair.

Building automation in Private Residential Buildings.

A big number of automated functions are used in many modern residential buildings. One of the most obvious examples is the use of control functions in automation in residential buildings. Exterior lights are often connected to motion detectors, so that they are turned on automatically should someone approach. Motion detectors detect the heat radiation of an approaching person. Combined with a brightness sensor, this ensures that the light only comes on if it is dark enough. Even though this is a comparatively simple automation function, it nevertheless illustrates the combination of event control and logical connections. This example focuses on comfort and ease of use. A more complex example of automation involves being able to turn all the lights.

To achieve this with a conventional electrical installation requires an immense amount of wiring, because each lamp needs to have its own wire connecting it directly to the one switch. By connecting

all the light switch components to a bus system over which they can communicate, you do not need as much wiring (Figure 16). Making it easier and more affordable to implement this panic button function. The focus here is on security. In summary, automation in private residential buildings focuses on:

- Cost effectiveness/saving energy
- Comfort and convenience
- Security

Building Automation in Commercial Buildings

Commercial buildings within the name of building automation are buildings which serves a purely functional purpose, for example, offices, hospitals, shopping centres and airport terminals. In modern buildings there are big number of automation systems for ventilating, lighting and air conditioning. To ensure these systems run correctly and economically, they are equipped with special controllers that are often interconnected to each other and to a control centre with field buses and networks. These control systems optimize energy usage and enable support and maintenance personal to carry out their jobs more efficiently.

Nowadays blinds and lights are controlled from office computers, increasing comfort and usability, in so doing. Systems in commercial buildings must be more flexible. If a company wants to restructure the structure of an office by converting a large conference room into big number of smaller offices, the set up and layout of the building's operational equipment have to enable these changes. Building automation systems enable companies to connect a light switcher to a light by simply reprogramming the intelligent devices, rather than rewiring the electrics. The focus there is on flexibility. To sum up, automation in commercial buildings focuses on:

- Cost-effectiveness and energy saving.
- Communication via networks and bus systems
- Comfort and convenience
- Flexibility

The Difference between Building Automation and Building Control

When we are talking about automated functions in buildings, the terms “building automation” and “building control” are mostly used. At first have a look over these terms appear synonymous.

Building automation is the computer based measurement, control and management of building services.

From that definition we can think that building control is a part of building automation. Building automation first time was implemented in commercial buildings to make possible running functions automatically. This also included the very first use of direct digital controllers (DDCs) (Figure 3) especially designed to control and monitor lights and electromechanical systems and appliances in the building. In addition, by using a control centre user can operate and monitor the systems more effectively, and also create a cross-system network. Building control is a specific subdivision of building automation which focuses mainly on electrical installations.



Figure 3. DigiPoint. Direct Digital Controller (DDC)

Building control stands for the use of an installation bus to make connection between system components and devices to system designed for a special electrical installation that controls and connects all the functions and processes in a building. All of this components have their own “intelligence” and can exchange information directly with each other.

Building control components. Such as Blind/switch actuator with manual mode (Figure 4), are usually mounted in a control cabinet or next to the device to be controlled (for example, a blind). Building control system does not require central DDCs.

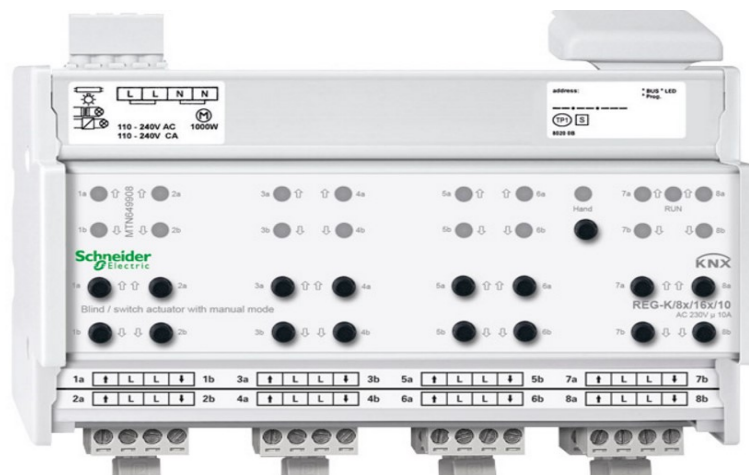

Figure 4. MTN649908. Blind/switch actuator REG-K/8x/16x/10 with manual mode.

Building automation involves coordinating and connecting all the systems in a building, so that they can communicate with each other. This can be achieved in three ways:

- Systems can be connected via DDCs and building control components. This is common in heating, ventilation, air-conditioning, lighting and shade control systems.
- Systems can also be connected via special DDCs that perform only input and output functions. This is common in sanitation and power supply systems that have their own in-built automation mechanisms.
- If a system needs to transfer a large amount of information or has its own computer, then it can be directly connected to the building automation control system. Data is then transferred via a bus system or network as opposed to over individual wires.

The interfaces between the individual operational systems of each facility must always be clearly defined in terms of data exchange and logistics.

In building automation, information technology is used to link all the systems in a building, enabling them to be centrally monitored by a control computer at the management level (Figure 5). Information exchange between the individual systems generally occurs at the automation level. Information is transferred over so-called peer-to-peer connections, which are logical pathways that use physical bus or network connections. [7]

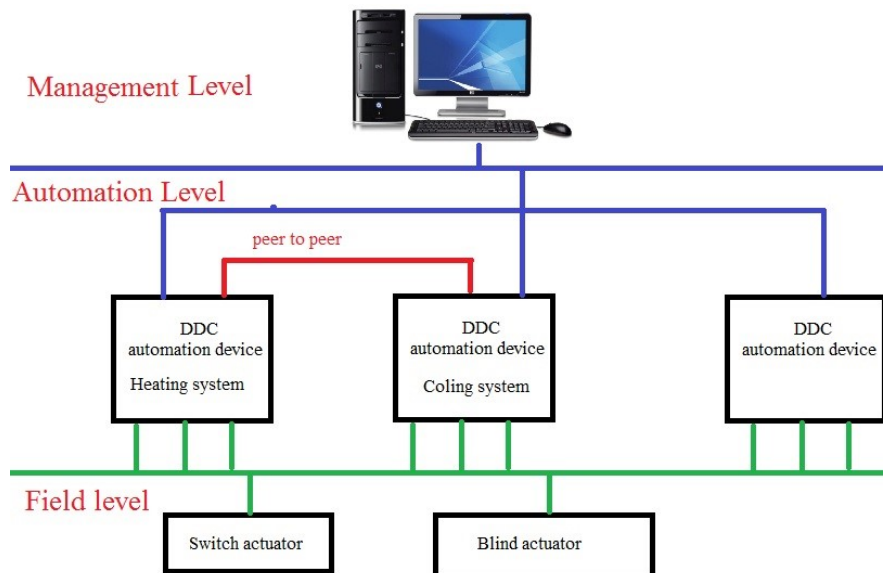

Figure 5. Network system in Building automation.

System	Room automation possible with building control components
Heating, cooling and ventilation	■
Lighting control	■
Shade/blinds	■

Table 1. Systems in building control.

The individual components for each application are pre-programmed for specific tasks. For example, an intelligent push button directly connected to the bus is used to send the signal to turn on or dimming a light with switch actuator.

These types of components are also used to control and regulate radiators. An electronic actuator is installed in the radiator and is connected, via the bus, to a temperature sensor near the door. For example. By installing a presence sensor near the door, you can ensure that as the last person leaves the room, the lights are automatically switched off and the radiator is turned down or off. The automated functions are processed by the building control components (Figure 17) and not by a central DDC.

Wires (usually twisted pair, Figure 15) connect the sensors and actuators to the DDCs that control and regulate the system(s). One of the wire pairs is used to transmit status messages and the other is used for transmitting sensor signals. The DDCs are mounted in a control cabinet. The close proximity of the control cabinet to the operational system interface reduces the amount of cabling required. Even a standard ventilation system installed in a commercial building needs —1.2 km of cable to send and receive 40 information messages. A terminal block is housed in the control cabinet and is used to connect the cables to the operational system, which is why it is called the operational system interface.

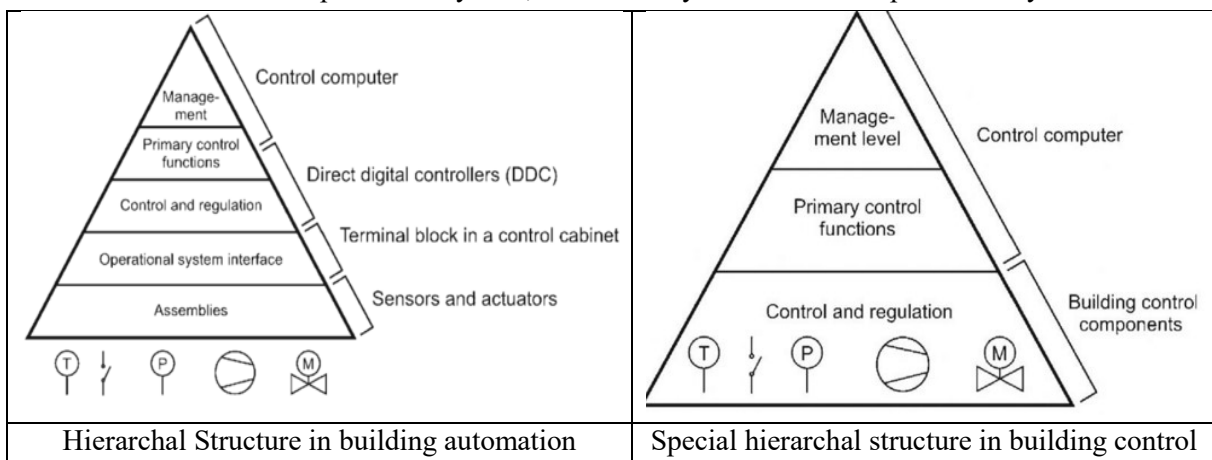

Figure 6. Structure of building control and automation Networks. [7]

2.5. Intelligent home supervisory control system (IHSCS)

A subsystem of home network, integrates electrical appliances, safety facilities, and other controllable devices into a whole with a home gateway. It realizes the intelligent control to devices in the house and supervision to surroundings. With the recent market growth in networks and popularization of digital commodities, research has intensified on intelligence technologies and application protocol for IWSCS, in particular, the middleware and BACnet protocol. [8]

BACnet provides a uniform digital communication protocol to connect the building control devices that are manufactured by a variety of vendors and make them exchange information with little cost. These technologies remarkably promote the intelligence and uniform the communication of IHSCS.

As a subsystem of home network, IHSCS provides surveillance and control services for users. It has the following four advanced functions: device control, device management, safety management, and video browse and surveillance Device control provides GUI and remote controllers for users to operate devices.

In order to uniform the communication of devices, BACnet protocol is desired. In a BACnet IHSCS, each controllable device is modelled as a collection of network-accessible, named entities called objects. Each object is characterized by a set of attributes of properties. [9]

2.6. Supervisory Control and Data Acquisition (SCADA)

SCADA systems used in energy management systems collect data in real time to control processes, and to monitor and control devices that are physically distributed. For many years, electric utilities rely on SCADA systems to sense, monitor, gather, and control their distributed physical infrastructures [10]

The implementation of new concepts like Smart Home and Smart Meter allows the domestic consumer to be an active player participating in the context of the Smart Grid (SG). An intelligent house management system should manage the power consumption but also the available micro generation system, the charge and discharge of the electric or plug-in hybrid vehicles, and the participation in Demand Response (DR) programs. The management should be performed in real time while meeting the consumers and the grid operators' requirements and preferences.

3. Energy Management

3.1. SCADA House Intelligent Management

The SCADA House Intelligent Management (SHIM) allows domestic consumers to improve the efficiency, the security, the comfort and to control all the available energy resources. The energy management system can be integrated in several devices like a smart phone or tablet allowing controlling and monitoring the installation. At the same time, the SHIM integrates several optimization methods to support the consumer energy management, allowing reducing the total consumption of the consumer in real time.

Some consumption loads as Heating, Ventilating and Air Conditioning (HVAC) depend directly on the internal and on the external temperature, and, in the case of lights, on the luminance of the room. Some others factors are common to all loads like the number of people, the persons activity, the persons presence. The SHIM is important to support the energy activity of domestic consumers allowing the efficient management to obtain economics benefits.

The development and the implementation of a SCADA system can be advantageous in controlling and monitoring the domestic consumer installation. It allows creating an interface between the consumer and its energy resources. The SHIM provides an interface to control and monitor several resources like distributed generation, loads, electric vehicles, security, system status and system configuration. [11]

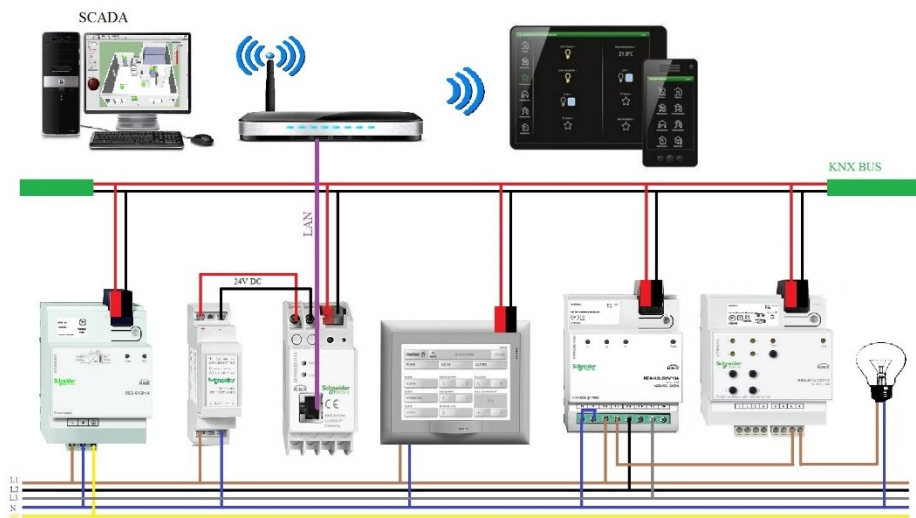

Figure 7. SCADA Home Intelligent Management.

3.2. Energy Management System using IEEE 802.15.4 and ZigBee

Recently, organizations use ZigBee to effectively deliver solutions for a variety of areas including consumer electronic device control, energy management and efficiency home and commercial building automation. The smart energy networks could include both ZigBee 2006 and IEEE 802.15.4.

A **ZigBee** device is a physical object equipped with a radio. Simple examples include a light switch, thermostat, and remote control. Logically separate functions may be implemented in a single device, and as such share the same radio for communication purposes. For example, a temperature sensor and actuator could be combined within a single device used for industrial plant monitoring application.

ZigBee networks include the following device types:

- **Coordinator** This device starts and controls the network. The coordinator stores information about the network, which includes acting as the Trust Center and being the repository for security keys.
- **Router** These devices extend network area coverage, dynamically route around obstacles, and provide backup routes in case of network congestion or device failure. They can connect to the coordinator and other routers, and also support child devices.
- **End Devices** These devices can transmit or receive a message, but cannot perform any routing operations. They must be connected to either the coordinator or a router, and do not support child devices.

The **IEEE 802.15.4** LR-WPAN employs various mechanisms to improve the probability of successful data transmission. These mechanisms are the CSMA-CA mechanism, frame acknowledgement. When the coordinator wishes to transfer data to a device in a beacon-enabled HAN, it indicates in the network beacon that the data message is pending. [12]

3.3. Energy Management Functions

As well as automated control and monitoring, one of the main tasks of building automation is to ensure that the systems in a building operate efficiently. This is known as energy management. In this section, we will describe some of the energy management functions most commonly used in building automation.

Energy meters

KNX energy meters allow measuring almost any physical quantity, such as electrical voltage, electrical current, active and reactive power, temperature, heat, humidity, etc. Data is collected in the background. KNX thermostats measure the room temperature inconspicuously. The measured data is used to identify unwanted energy consumption and is evaluated automatically by KNX. Depending on the type of KNX installation, actions can be also performed automatically. By the KNX, during the holidays an open window in the house can be detected and automatically closed with KNX (if equipped with a motor). As a result, the building Operator saves heating costs. KNX thermostats can optimally control floor heating, heat pumps and air conditioning systems – even interactively. The consumer saves money. [13] Suitable for installation on DIN rails TH35 according to EN60715.

Benefits of smart meters:

- Optimize energy consumption and enable energy efficiency practices.
- Collect and analyse energy consumption data from each area for each type of load or circuit
- Use information to implement actions designed to reduce energy consumption
- Monitor the energy consumption of tenants or customers and establish accurate invoices
- Drive energy-efficient behaviour. [14]

Energy Management Functions at the Automation Level

The programs for optimizing energy consumption can often be assigned to an individual system. In particular, if regular adjustments do not have to be made, then the necessary functions can be programmed directly into the system's DDCs. The programs can then be left to implement these functions automatically, and only need to be reprogrammed if structural changes are made to the system.

Table 2. Energy meters.

		
<p>KNX Energy Meter - MTN6600-0603</p>	<p>energy meter MID IEM3155</p>	<p>KNX Metering Gateway- MTN6503-0201</p>

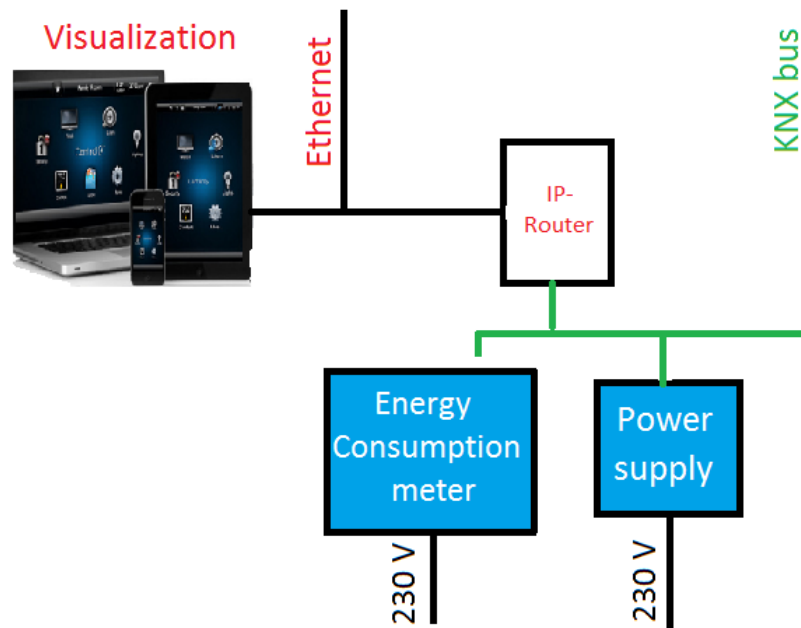

Figure 8. KNX Energy metering architecture.

Demand-Driven Setpoint Adjustment

A common example is the weather-controlled regulation of a heating system’s flow temperature (Figure 9) that uses the outside temperature to adjust the heating controller’s setpoint value. When the outside temperature is low, the heating system’s flow temperature is increased; and when the outside temperature is moderate, the flow temperature is reduced to the lowest possible value.

This function can also be used during the summer. If the outside temperature is very high, the room temperature setpoint can be increased without the user noticing. This “summer mode” helps to save energy by reducing the amount of air cooled by the air-conditioning system. By minimizing the difference between the outside temperature and the temperature in the room, this function also prevents the user from experiencing any adverse effects to his or her health.

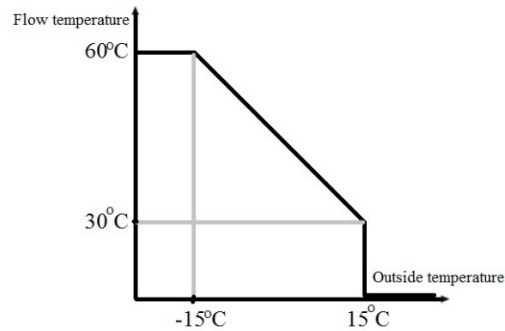

Figure 9. Demand-Driven Setpoint Adjustment.

Real-Time Control

There are many examples of real-time load control. A simple example uses presence detectors in a room to activate the lighting control system as soon as someone enters the room.

Monitoring Energy Consumption

The energy costs in many buildings are neither recorded nor calculated. Significant savings, however, can be made, particularly in research or production facilities, if you can determine exactly how much energy each load is using.

This idea can also be easily and affordably implemented in commercial buildings by combining the energy meters (**Error! Reference source not found.**) from all the types of energy. Furthermore, by connecting the control computer to a commercial accounting system, you can then create a report automatically.

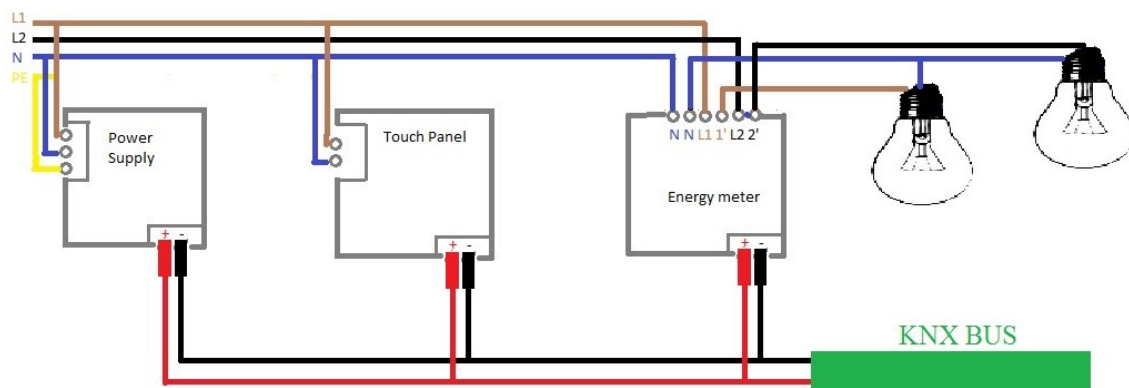

Figure 10. Monitoring Energy Consumption.

Energy monitoring

Each KWh used by loads are sent from the energy meter to the KNX binary input as number of pulses. Consumption data is then transferred to the 10" IP touch panel, where it can be viewed and checked. The touch panel can also be used to view and control current building states and functions.

Benefits

- Reduce energy consumption by up to 10% and more: as displayed values encourages end user to reduce energy consumption.
- Increase safety by automating alarms and emergency calls
- flexible remote monitoring and control

Scheduled Start/Stop

Another energy management function involves programming scheduled processes.

Energy costs can be reduced by turning off non-essential systems when the building is not in use.

A lighting control timer-switch program can be programmed to turn on certain lights at specific times depending on the time the sun rises. These programs are also often used in private residential buildings.

All heating controllers have timer-switch programs for reducing the temperature at night.

In commercial buildings, these functions are usually programmed into the main control computer, which means you can easily make changes as and when you need to. For example, you can make one-off adjustments to the timer-switch programs in the main control computer for evening conferences or events. (See heading 7.3)

3.4. Consumption of electricity in Czech Republic over the years.

Definition of Electricity - consumption: This entry consists of total electricity generated annually plus imports and minus exports, expressed in kilowatt-hours. The discrepancy between the amount of electricity generated and/or imported and the amount consumed and/or exported is accounted for as loss in transmission and distribution.

In this century there has been a large increase of electricity demand. People start using more and more home appliances, replacing petrol cars with electric cars. As using electric equipment is less expensive and has no effect of pollution.

There is shown increased electricity demand in Czech Republic, by using more and more techniques. Consumption of energy can be reduced appreciably and that is what every person wants to pay less for Electricity Bill. (Figure 12)

According CIA World Factbook measured electric power consumption (kWh) in Czech Republic in 2015 and it was about 74billion (Figure 11). The measurement includes produced, transported and distributed loses and own used electric power by the power and heat plants.

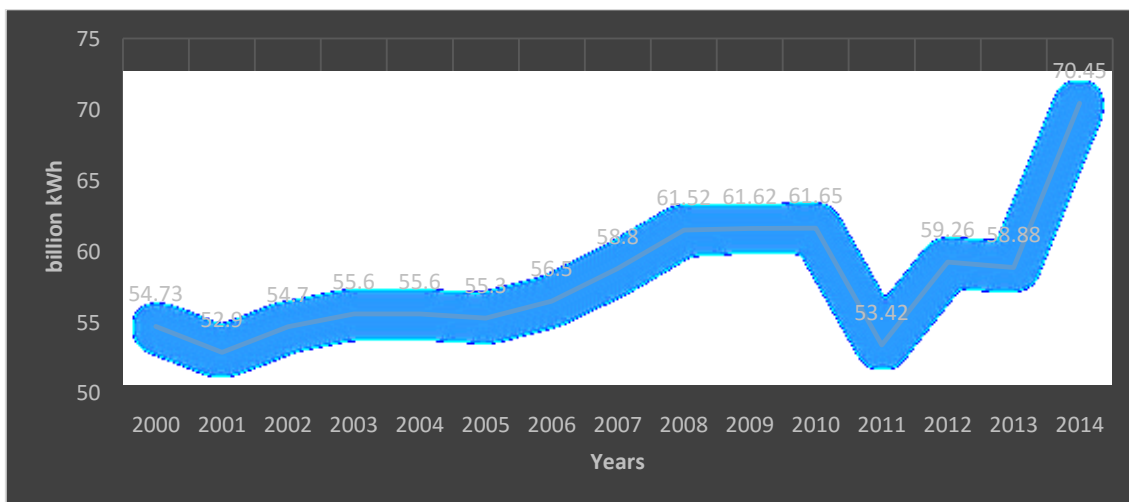
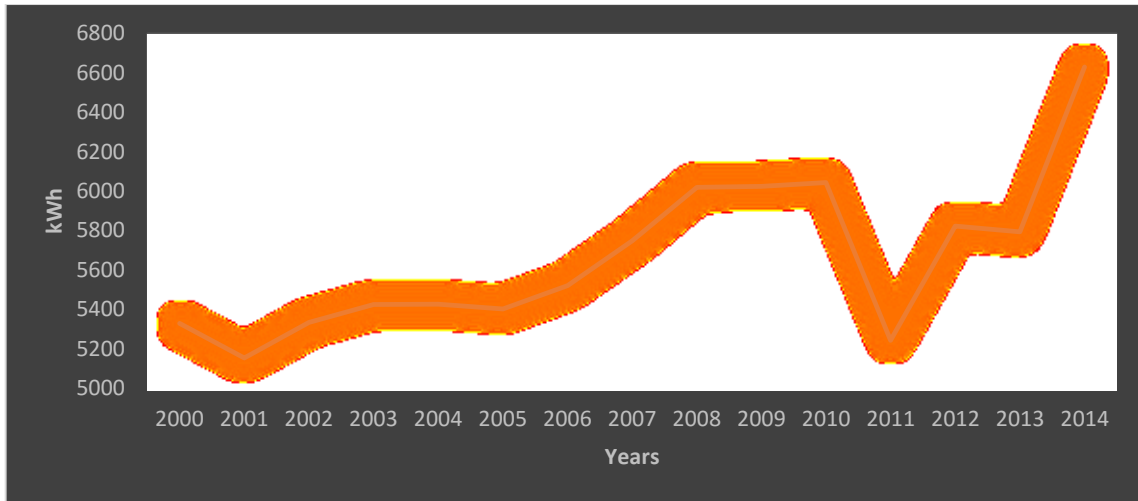

Figure 11. Presents the increased value of electricity consumption in Czech Republic.

[15]



[15]

Figure 12. Electricity consumption per capita (kWh per person)

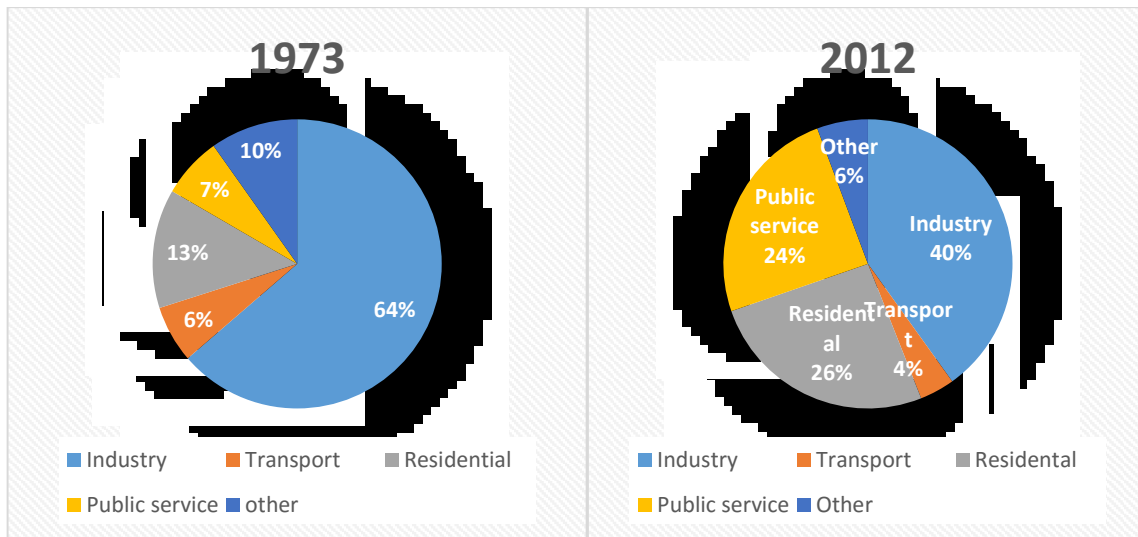

[16]

Figure 13. Presents increased electricity demand by the inhabitants.

The IEA - International Energy Agency estimates that 26% of end use electricity in the Czech Republic is consumed in residences. Concomitantly, household appliances, consumer electronics, and construction techniques are becoming increasingly efficient. Using smart meters the end-user is enabled with near-real time information from the service provider. This presents an opportunity to coordinate the management of appliances and other loads in the smart home, considering information flow and end-user behaviour. [16]

4. Technologies used in smart home

4.1. Current Standards

There are many proprietary bus systems and networks on the market, but only a few have actually been standardized.

The European and international standardization processes are drawn out affairs. Systems in the pre-standard phase of the European standardization process are denoted by the letter ENV. EN stands for European Standards and ISO/IEC refers to International Standards from the International Organization for Standardization.

LON technology and the **Konnex**, **BATibus**, and **EHS** bus systems are used at the field level and are included in the international standard ISO/IEC DIS 14908, in the ANSI/ASHRAE 135, and in the European standard EN 50090.

BATibus is widely used in southern Europe and the Electronic Home System (**EHS**) is a bus system for transmitting data using the power supply network.

BACnet (ISO 16484-5) is the main system used at the automation level. Other protocols used at this level include Profibus (used in industry automation) and the French Field Instrumentation Protocol (**FIP**). **LON** is no longer a standardized automation level protocol, but it's as a transmission medium for **BACnet**. **BACnet** is the only protocol used for data communication at the management level. In Europe it has replaced the Firmenneutraler Datenaustausch (**FND**) protocol, which was developed by contracting authorities to enable data exchange between control computers made by different manufacturers.

Field Bus Communication

At the field level you will find sensors (Figure 18) and actuators (Figure 19) — the so-called field devices. Functions typically carried out at the field level include switching. Setting. Reporting, measuring and metering. Field devices used on the field bus have in-built microcontrollers and are, therefore, referred to as ‘intelligent’ components. They send and receive messages (a series of bits) over a bus, communicating either directly with each other or with control and regulation devices at the automation level above.

A field bus is a digital serial data bus that enables communication between industrial automation devices such as meters, regulators and programmable logic controllers IIEC 61158: field bus for industrial control systems, IEC 61784: digital data communication in control systems.

Field bus technology was first developed in the 1980s as part of the drive to increasingly decentralize automation solutions. The aim was to replace standard parallel transmission technology using analog data transfer with serial transmission technology using digital data transfer. There are currently various field bus systems on the market. Their specifications (e.g., transfer rate, cable length or the number of devices) vary depending on the requirements of the particular field they are used in. Field buses can only transfer small amounts of digital data (bits and bytes) in a short space of time.

Communication over Networks

Information is transferred from the automation level to, for example, visualization and production planning systems at the management level. Larger amounts of information are transferred than at the field level and more time is available to do so.

Communication at the automation level takes place primarily over local area networks (LANs).

A network uses wires or radio waves to connect various technical systems such as computers and control devices so that they can communicate with each other.

For binary signals two signal elements are used for line coding the bit's two states (values). This means that the hit rate V_{bit} and modulation rate u are the same. However, this only applies to binary signals where only one bit is transmitted at a time.

You can also transmit, for example, two bits (Dibit) at a time by using four different signal elements and assigning a specific combination of hits to each signal element (Table 3).

For the "10" bit combination, the line coder sends the signal element 3. The bit rate is now twice the modulation rate.

Bit combination (Dibit)	Signal element
00	1
01	2
10	3
11	4

Table 3. Combinations of bits and signal elements.

4.2. BACnet

BACnet (Building Automation and Control networks) is a standard data communication protocol for building automation and control systems. The purpose of the BACnet network layer is to provide the means by which messages can be relayed from one BACnet network to another, regardless of the BACnet data link technology in use on that network.

BACnet Router is the BACnet network layer interconnect equipment, and its role is to connect BACnet networks, form BACnet internet, and route messages between BACnet networks. In addition, establish and maintain routing tables, network congestion control is one of the main contents of the BACnet network layer. [17]

BACnet routers are devices that interconnect two or more BACnet networks to form a BACnet internet work. BACnet routers make use of the BACnet network layer messages to maintain their routing tables. In the process of the BACnet network communication, there is a possibility that the router's message buffer overflow. Therefore BACnet routers need to have a mechanism to temporarily suspend the reception of messages from all or a specified network, which is the BACnet routers congestion control. In BACnet standard, Router-Busy-To-Network, Router-Available-To-Network and Reject-Message-To-Network messages have relation with the BACnet network congestion control. [18]

BACnet is based on the Open System Interconnection (OSI) reference model (ISO 7498).

The BACnet protocol defines how and which messages (data frames) can be transported from one device or system to another. The messages can contain the following information:

- Binary input and output values ("window open/close")
- Analog input and output values ("current through temperature sensor")
- Software binary and analog input and output values (reading in °C from a temperature sensor)
- Schedule information
- Alarm and event information (movement detector, door contacts)
- Files (for securing configuration settings)
- Control logic

It is developed by the American Society of Heating, Refrigerating, and Air-Conditioning Engineers (ASHRAE). Modern building automation and control systems provide a variety of building services such as heating, ventilating, and air-conditioning (HVAC), lighting, fire and life safety systems, security, and transportation. BACnet is used to integrate these building services with integrated control networks. [19]

BACnet network is a control network. The different priorities of the BACnet network layer message show the urgency degree of the application. BACnet routers must handle BACnet network layer messages in accordance with the order of the priority. Otherwise, it will affect BACnet network's reliability. Once BACnet routers receive high-priority messages, we must ensure that the highest priority messages are disposed firstly and for this we should not hesitate lose some low-priority messages.

BACnet Testing Laboratories was established by BACnet International to test products as per BACnet standard and support compliance testing and interoperability testing activities and consists of BTL Manager and the BTL-WG. The general activities of the BTL are:

- Publish the BTL Implementation Guidelines document
- Certifying the products as per BACnet guidelines

- Support the activities of the BTL-WG,
- Maintaining the BTL test packages for technical support for use of pre-testing
- Approves Testing Laboratories for BTL Testing.

The standard specifies 54 types of objects [20]:

Table 4. BACnet objects.

Access Credential	Analog Input: Sensor input	Calendar	Date Time Value	Large Analog Value	Multi-state Value
Access Door	Analog Output	Channel Object	Device	Lighting Output	Network Security
Access Point	Analog Value	Character String Value	Event Enrollment	Life Safety Point	Notification Class
Access Rights	Averaging	Command	Event Log	Life Safety Zone	Notification Forwarder
Access User	Binary Input	Credential Data Input	File	Load Control	Octet String Value
Access Zone	Binary Output	Date Pattern Value	Global Group	Loop	Positive Integer Value
Accumulator	Binary Value	Date Value	Group	Multi-state Input	Program
Alert Enrollment	Bit String Value	Date Time Pattern Value	Integer Value	Multi-state Output	Pulse converter
Schedule	Time Pattern Value	Structured-View	Time Value	Trend Log	Trend Log Multiple

A **BACnet/IP** network is a collection of one or more IP sub networks (IP domains) that are assigned a single BACnet network number. A BACnet internetwork (3.2.26) consists of two or more BACnet networks.

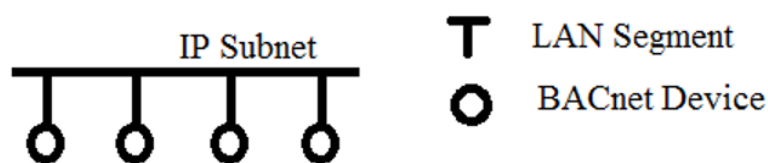

Figure 14. BACnet/IP internetwork

4.3. KNX

Konnex (KNX), formerly known as the European Installation Bus (EIB), is a (industrial) building control communication system that uses information technology to connect devices such as sensors (Figure 18), actuators (Figure 19), controllers, operating terminals and monitors. KNX technology is designed to be used in electrical installations for implementing automated functions and processes in buildings.

KNX was ratified by CENELEC as the European Standard EN 50090 in December 2003. In 2006 a large section of the EN 50090 standard was approved for inclusion in the ISO/IEC 14543 International Standard, making KNX the only worldwide open standard for home and building control. [7]

KNX is a fully integrated system for home and building automation for the implementation, flexible and cost-effective solutions. Its functional versatility is not used only in simple and limited installations but also enables solutions for the whole building sector. KNX corresponds project design and installation, commissioning, operation of the bus system and maintenance. [21]

4.3.1. KNX protocol.

The standard is based on the communication stack of EIB but enlarged with the physical layers, configuration modes and application experience of BatiBUS and EHS.

KNX defines several physical communication media:

- Twisted pair wiring (inherited from the BatiBUS and EIB Instabus standards)(Figure 15)
- Power line networking (inherited from EIB and EHS - similar to that used by X10)
- Radio (KNX-RF)
- Infrared
- Ethernet (also known as EIBnet/IP or KNXnet/IP)

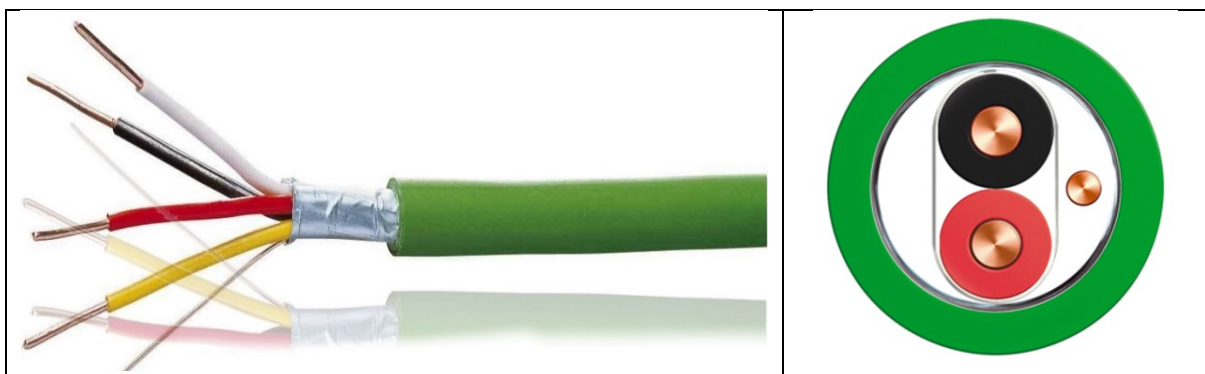

Figure 15. Twisted pair cable

KNX is designed to be independent of any particular hardware platform. A KNX Device Network can be controlled by anything from an 8-bit microcontroller to a PC, according to the needs of a particular implementation. The most common form of installation is over twisted pair medium.

KNX is approved as an open standard to:

International standard (ISO/IEC 14543-3)

Canadian standard (CSA-ISO/IEC 14543-3)

European Standard (CENELEC EN 50090 and CEN EN 13321-1)

China Guo Biao (GB/T 20965).

Wire transmission.

Twisted pair using differential signalling with a signalling speed of 9600 bit/s. Ideal wave resistance at 100 kHz is 120 Ω . Line resistance at 20 Ω /km, max 75 Ω /km. Maximum capacitance bus-to-bus line max 800 pF/m at 800 Hz. Higher capacitance requires proportionally shorter cable length.

Media access control is controlled with the CSMA/CA method Maximum segment length is 1000 m. 4 segments may be connected with line repeaters to establish a network length of 4000 m. Loops are not allowed. Source is always a physical address. Destination may be either a physical or group address. Logical "0" is defined as impulse under the reference level 30 V DC. Logical "1" is lack of the same impulses.

There exists an alternative interface speed at 4800 bit/s taken over from BatiBUS. But KNX TP-0 products will only operate on the same network. But not be able to exchange information with BatiBUS devices. [22]

KNX OPC

The KNX OPC Server provides secure and reliable real-time data access between all KNX and any OPC-enabled applications such as Historians, HMIs, and SCADA ...etc. KNX OPC Server securely communicates over Ethernet (EIBnet/IP or KNXnet/IP) to all KNX devices on the building automation networks to maximize control over the Building Management System.

The OPC Server for KNX supports the following features and operations:

- Automatic device discovery and binding,
- Runs on Windows 2008, Windows 7, Windows 2003, and Windows XP
- Uses common item syntax and delimiters to make the integration with HMIs and OPC clients easier.
- Export to and from the ETS database,
- All objects and nodes are searchable from any OPC client,
- Supports the ETS Network Management tool,
- Multicast for device discovery and Unicast for Device data,
- Log I/O messages as A&E data and in log file,
- Retrieve KNX objects' data types,
- Channel and device level Redundancy.

The KNX OPC Server automatically generates the server's configuration to make it easy to control and monitor:

- Lighting control (switching; dimming; "mood lighting")
- Shading control (shutters; blinds)
- Heating, ventilation, air-conditioning (individual room temperature control; control of radiators, terminal units, boilers, coolers, fans, ...)
- Access and security (presence detection; burglary and fire detection and alarm; presence simulation; panic switch)
- Energy management (consumption metering; load shedding; ...).
- Comfort functions and intelligent control across all applications (central user control; combined scenario's; intelligent process control; ...)
- Remote control and remote maintenance (e.g. via phone or Internet) [23]

This simplifies planning and implementation of building functions and provides superior functionality, flexibility and comfort without any additional effort and expense. There is no need for a control centre,

because each device has its own microcontroller. By setting the appropriate parameters – which can be modified at any time – you can tell the device exactly what it is supposed to do. This makes a KNX system extremely flexible, allowing you to adjust and expand it to meet new requirements at any time. Whether in a house or a commercial building, KNX can be used to control the heating, lighting, air conditioning and security systems automatically.

The advantage: buildings can be easily and conveniently run and used.

- The conventional solution: Many separate cables, separate functionality, little flexibility
- The intelligent solution: KNX – a system, a standard, many interoperable functions for maximum flexibility. Figure 16

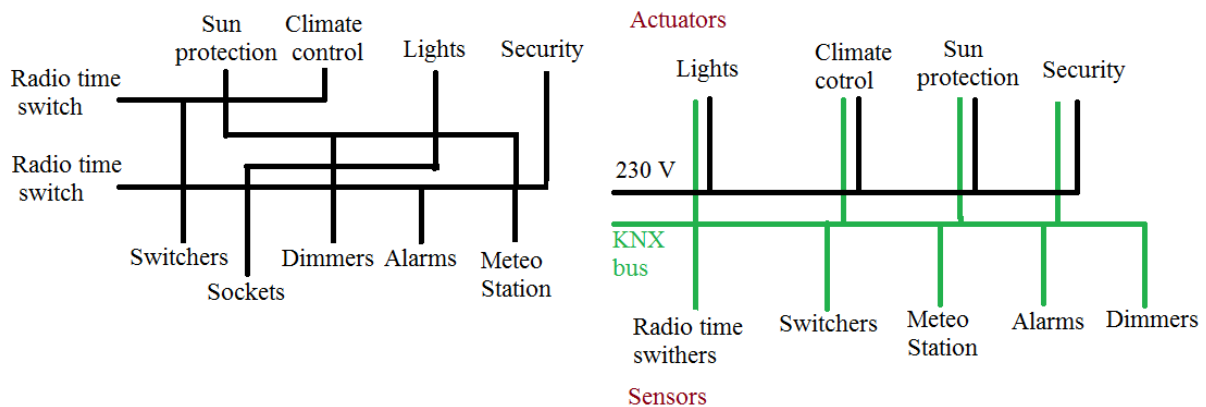

Figure 16. Standard and KNX solution. [21]

The key strength of KNX is its power to effectively connect all areas of installations.

Areas of application include:

- Lighting Control)
- Central Heating / Air Conditioning Control
- Electric Blind Shutters (Figure 27)
- Security Systems Control (Intruder alarm / CCTV)
- Safety Systems Control (Smoke detectors / CO2 Sensors)
- Door Entry Systems Control
- Entertainment System Control (Audio /Visual)

4.3.2. KNX system components

Various types of bus devices are required in a KNX installation such as the lighting control system for an apartment building. Each specialist manufacturer normally offers dozens of different types of KNX products, giving you a few thousand KNX bus devices to choose from. The devices are classified into different groups such as sensors, actuators, and so on. This makes it easier for you to not only find the products you need, but also to compare them to see which is best suited for your installation. [7]

All the devices for a KNX installation are connected together by a two wire bus (the most common form of installation), thus allowing them to exchange data. The function of the individual bus devices is determined by their project planning, which can be changed and adapted at any time.

- Sensors (push buttons, wind-, temperature-, movement-sensors)(Figure 18)
- Actuators (dimming units, electrical heating valves, displays)(Figure 19)
- System devices and components (Line-Couplers, Backbone-Couplers) (Figure 17)

KNX allows different bus topologies: Tree, line and star topologies. These topologies can be mixed as needed. However, ring topologies are not allowed. The tree topology has advantages over other topologies in cases where a large network has to be created.

KNX is a fully distributed network, which accommodates up to 65,536 devices in a 16 bit Individual address space. The logical topology or sub network structure allows 256 devices on one line.

System devices

KNX devices are needed for the main functioning of the system. They consist of power supply units for generating bus voltage, couplers for connecting bus segments and interfaces for connecting programming devices

As lighting control is an integral part of nearly all KNX projects, you will often find these three devices in KNX systems. A power supply unit is essential anyway because the bus cannot operate without it

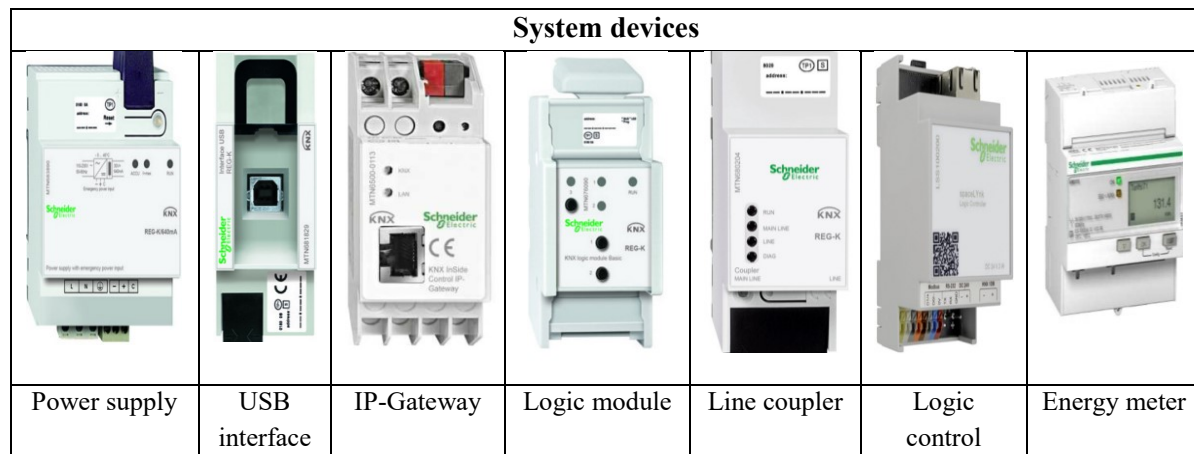

Figure 17. System devices

Sensors

Sensors are the starting point for each action, thus they gather information and send it on the bus as a data telegram. This can be information about room lights, movements, weather measurements or manually input instructions.





Sensors				
				
Push-button	Basic weather station	Binary input	Room temperature control unit	Presence detector

Figure 18. Sensors

Actuators

Actuators receive data which are later converted into actions. This can include dimming lights, controlling blinds or controlling heating and air conditioning systems.



Actuators		
		
Blind actuator	DALI gateway	Switch actuator

Figure 19. Actuators

4.3.3. The ETS concept.

For the planning, project design and commissioning of KNX systems, a uniform program for the project design and commissioning of the KNX system is available for planners and installers. ETS stands for Engineering Tool Software. ETS™ is a registered trademark of the KNX Association. ETS5 is the current version of ETS. On the one hand, ETS5 is a newly developed software program. [24]

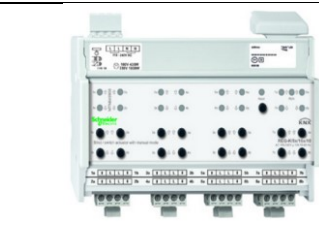
- Guarantee of maximum compatibility of ETS software with the KNX Standard
- All product databases with certified products from all KNX manufacturers can be imported in ETS
- Backward compatibility of ETS to product data and projects of earlier ETS versions (as far back as ETS2) safeguards your working results and allows editing.

Everywhere in the world all designers and installers use one and the same ETS tool for every KNX project and with every KNX certified device. Reliable data exchange is therefore guaranteed. [25]

Project design and building in ETS5

A project consists of KNX devices and links between them. In the actual installation the devices themselves are located in building parts, i.e. rooms. First step is adding building than floors and other parts such as rooms, corridor and cabinets (Figure 20).

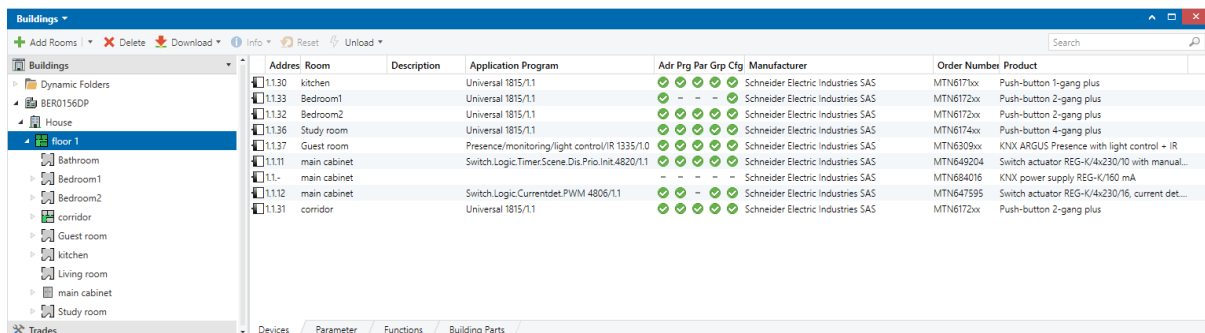

Figure 20. Building parts

In the second step the desired devices are inserted into the previously created room via the panel catalogue. After this the links (in KNX terms “Group addresses”) between the different devices (more precisely group objects) are created. (Figure 21)

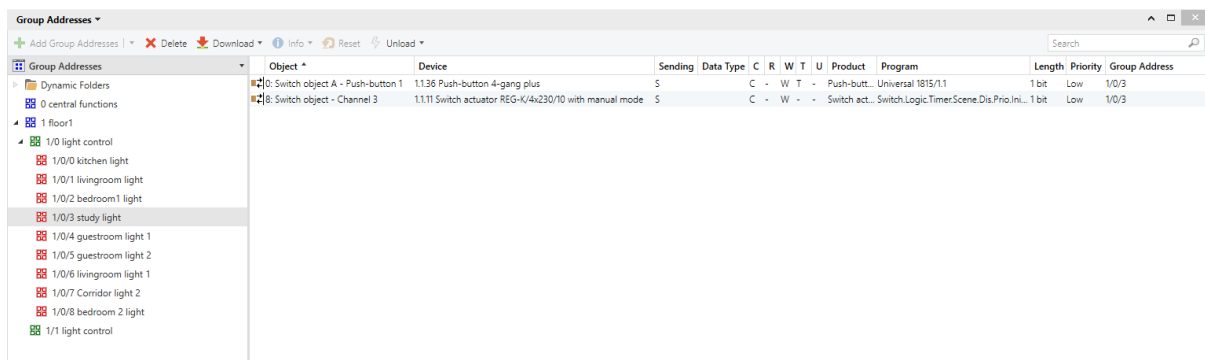

Figure 21. Group addresses

In the following step, certified KNX products of various KNX manufacturers are imported. To do so, you will have to switch to the ETS “Catalogue“ panel, where one should choose the function “Importing“

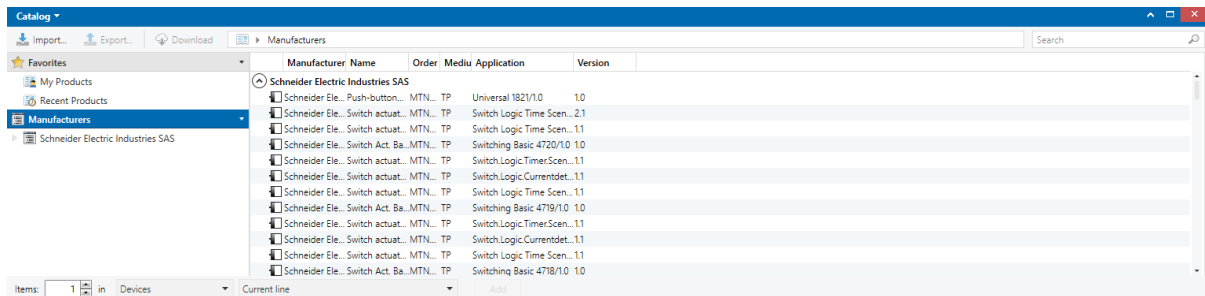

Figure 22. Manufacturer Products (Catalogue)

Once all the settings have been done, a download of the parameters into the devices is initiated. For this, all necessary devices are marked as green tick and the loading function is called via the context menu (right click) or the menu bar.

The status indicates whether the loading process was completed correctly or whether errors occurred. If one wishes to verify this, a specific device can be selected and the status can be explicitly retrieved. [26]

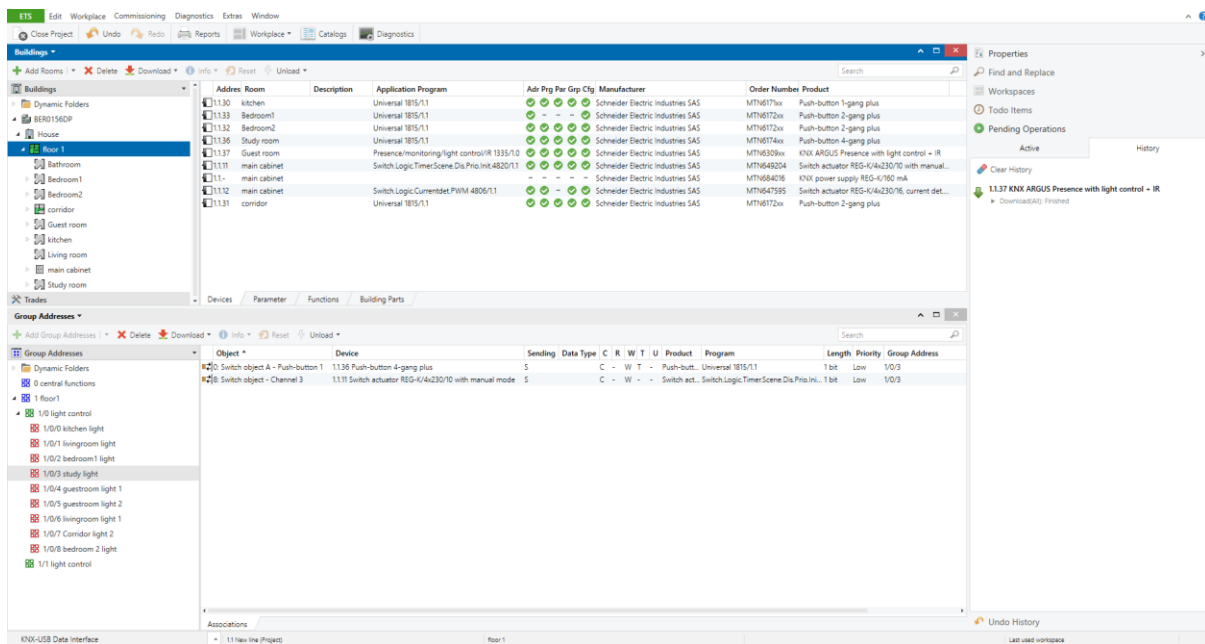

Figure 23. Light control programming

4.4. LonWorks

LonWorks is an open networking solution for building automation and control networks that was developed by the American company Echelon. It is designed in such a way that it can be used in centralized building automation controllers as well as in decentralized building control components.

LON technology has become an integral part of building control. Distributing measurement, monitoring and control functions among local, decent rally installed components means that you can customize a variety of comfort solutions for an individual room. For instance, there is a wide range of sensors and actuators on the market for implementing the following functions:

- Heating, cooling and ventilating
- Lighting control
- Shade/blind control
- Security
- Multimedia

Building control focuses mainly on room automation and is becoming increasingly important in private residences as well as in commercial buildings. For this reason, some turnkey manufacturers offer the option of installing LON instead of conventional installation technology.

In building control, LON technology is used primarily for the decentralized processing of automation functions in room automation. User can use different processors to scale the system's performance and capability, which means that LON can also be used at the automation level. This level can carry out monitoring, controlling and regulating functions for building services such as heating and ventilation systems.

LON technology is predominantly used for industrial (35 %) and building automation in commercial buildings (35 %), home automation (15 %), and transportation and public utility control networks (energy distribution) (15 %). [7]



Figure 24. LON DDC controller.

The LON controller is an interoperable, LONMark compliant controller. The LON controller has factory loaded application specific software which allows optimal control of our water source heat pumps in buildings which require DDC control.

The ASW01, ASW02, and ASW03 sensors are digital wall mounted temperature sensors to be used with the LON controller. The LON controller and ASW digital wall sensors communicate via Sensor Link (S-Link) communications protocol. S-Link is a simple two wire communication protocol which provides power to the ASW wall sensor as well as transmits information between the ASW wall sensor and the LON controller. The S-Link protocol is NOT polarity sensitive and does NOT require shielded cable. [27]

LonTalk Protocol

The LonTalk protocol defines how Neuron Chips are programmed for different applications and how they communicate with each other as nodes in a network. This requires a standard language, or communication protocol. The LonTalk protocol is an integral part of the Neuron Chip and is embedded directly in the chip as firmware. This ensures that all LON nodes connected with each other on the same network are compatible.

Each network device has a transceiver – short for transmitter and receiver. The transceiver provides a physical communication interface between a LonWorks device and a LonWorks network.

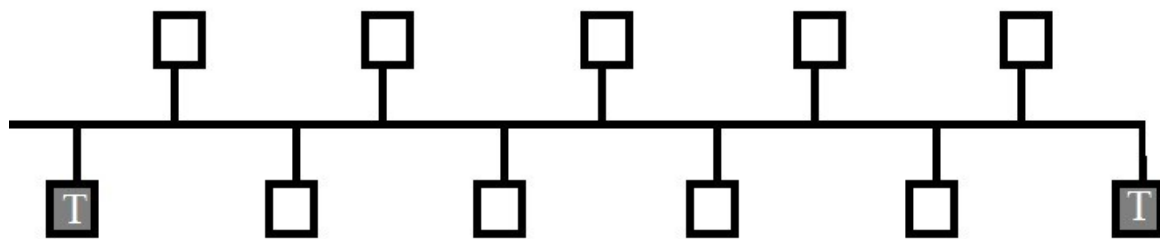

Figure 25. LON nodes in bus topology with terminators.

LON nodes that have a direct relationship with each other should be directly connected to each other. The greatest distance can be achieved using a bus topology. Two types of bus topology:

- Star network
- Loop topology

A star or ring (loop) network can have a maximum range of 500 m. The maximum distance between two LON nodes must be no more than 320 m, depending on the type of cable. A terminator with the value $R = 52.3 W$ is placed at the end of the network.

A sub network (subnet) represents the smallest part of a LON network. A subnet can contain a maximum of 128 addressable LON nodes. A repeater connects two segments of the same medium and forwards, but does not filter, valid data frames. A maximum of three repeaters can be installed in a row; more can cause signal delays, which can lead to communication problems.

A LON device can be used for different purposes. The LON bus coupling unit with the KNX operating panel, can be used as a lighting or blind controller or a setpoint adjuster

5. Comfort, Convenience, and Functions in Room Automation.

5.1. Room automation

Room automation is becoming increasingly important in both residential and commercial buildings. As well as the increase in comfort and convenience and the array of potential energy management functions, commercial buildings also need to have a high level of flexibility. You need to be able to easily customize these buildings to meet any change in use or requirements, for example, converting a conference room into two separate offices for new employees. By implementing well-planned building control, you can adjust many programs to meet the specifications of each of the new rooms. Traditionally this would have meant having to completely rewire the electrical installation. Instead you now simply reprogram the necessary components.

In private residential buildings, on the other hand, security is far more important than flexibility. After all it is not often we need to convert a bedroom into a kitchen.

Below is a summary of the comfort and convenience functions for each system.

Some functions can also incorporate more than one system.

5.2. Heating, Cooling, and Ventilation:

- Configuration-dependent setpoint adjustment of the room temperature via an occupancy switch or presence detector
- Use-dependent setpoint adjustment of the room temperature in hotel rooms by connecting each room to the booking system
- Adjusting the room temperature using a setpoint adjuster
- Automatically increasing the room temperature setpoint in summer when the outside temperature is high
- Shutting down the heating and cooling systems as soon as a window is opened
- Adjusting the ventilation depending on the air quality in the room

5.3. Lighting Control:

- Configuration-dependent activation of the lighting in a room via an occupancy switch or presence detector
- Use-dependent activation of the lighting in hotel rooms by connecting each room to the booking system
- Using a brightness sensor to constantly control the lighting in a room
- Adjusting the brightness in the room depending on the light outside
- Diffused lighting control by adjusting the angle of the blind slats depending on the position of the sun
- Light switch for cleaners — which temporarily increases the amount of light in room
- Lighting scenes

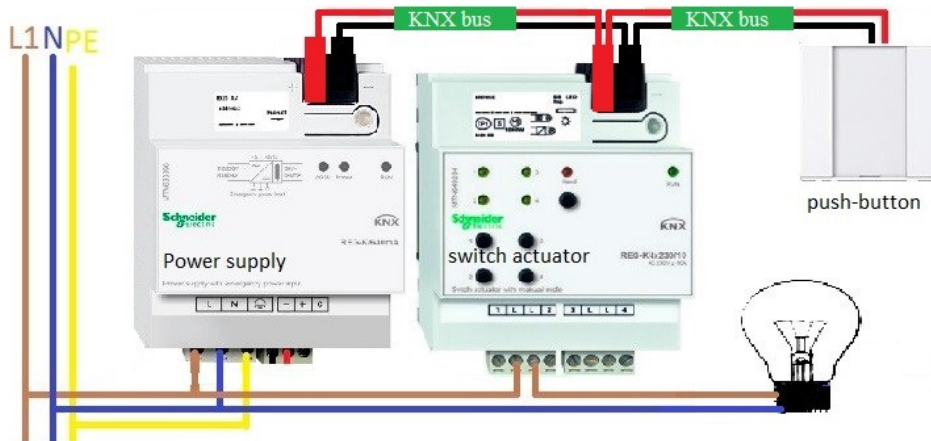

Figure 26. Simple example of light switching and dimming control.

5.4. Blind and Shutter Control:

- Controlling the amount of sunlight that is let into the room, depending on the time of day
- Constant lighting control to prevent too much sunlight from shining directly into the room by altering the angle of the slats on a blind
- Winter/summer mode:
 - To prevent the room from heating up too much in the summer
 - To ensure that as much sunlight is let into the room as possible during the winter
- Raise the exterior blinds automatically if it is too windy outside

Blinds control according the weather using weather station:

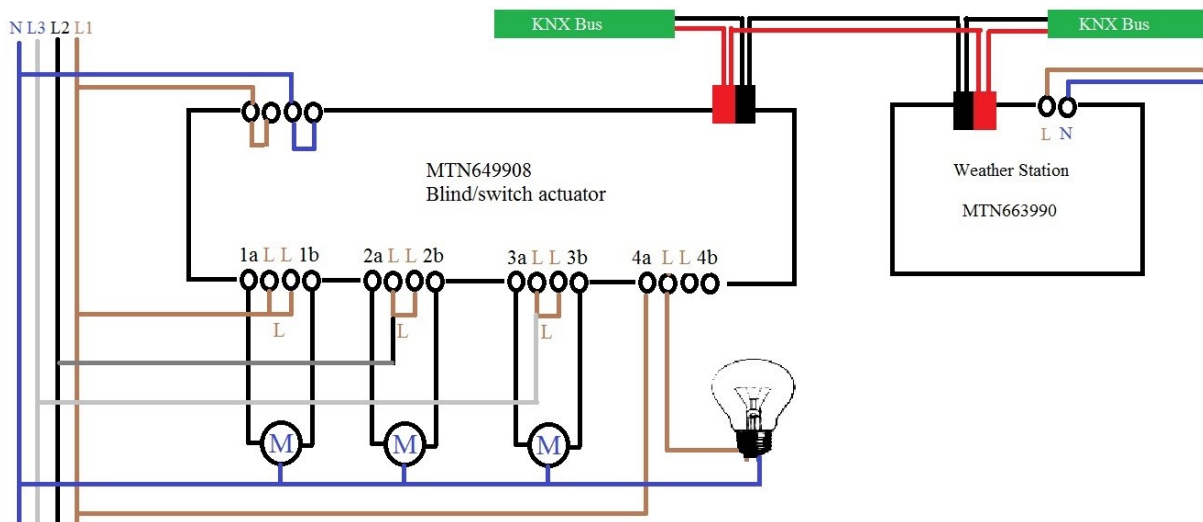

Figure 27. Blinds, lights control with weather station in KNX.

5.5. Security:

Security is common in smart home technology where it comprises physical security and network security. The physical securities are focused on the protection of the house and securing the house from strangers or trespassers. As for network security, smart home is to provide secure network busing encryption over data transmission. The existing physical security provided by smart home may not intelligence enough to take adequate actions based on the information gathered from the environment and address the higher level needs of users.

- Illuminating the emergency escape route in case of a fire
- Smoke detectors in the room to control the extraction of smoke via electrically operated windows
- Displaying the building's evacuation plan on every office computer screen in an emergency
- Panic switch for switching on all the lights in the building
- Presence simulation for the lighting control system
- Room access using a key card or biometric scan

5.6. Multimedia:

Activating lighting scenes, for example, switching on a projector for a presentation will automatically dim the lights and close the blinds

- Customizing room settings by connecting audio and video servers
- Control the systems in a room using a personal digital assistant (PDA), cell phone, or computer

6. Mobile laboratory project

6.1. Project design

Introduction

We offer you a unique mobile laboratory plan for energy measurement, which helps in designing and planning the installation of building automation with KNX technology.

KNX is a global standard, which products are already produced by more than 200 manufacturers, HVAC household appliances. Each device on KNX is certified by the organization Konnex and bear the mark of KNX, which ensures compatibility of the device / product standard. Currently, there are over 2 500 such devices. Certification of devices is also a guarantee that the installation of KNX after long years of operation can be expanded at any time and legacy devices without obstacles can work with it for years. In addition, older devices easily can be replaced by newer, if there is such necessity. System can manage KNX installations for lighting, dimming and blinds, shutters, HVAC (heating/cooling/ventilation).

Due to the fact that KNX is an open system, can also be integrated with other communication protocols such. BACNET, LON, Modbus, M-bus. Wide range of available KNX lighting control (motion detectors, presence, switching actuators and dimming) control devices blinds (weather stations, timers, actuators shutters, curtains) control equipment for comfort (actuators for heating, fan-coils, input / output analog and digital, thermostats, temperature sensors, humidity, carbon dioxide, opening windows).

Measuring instruments and control (counters consumption of electricity, water, gas, heat, and controlled shut-off valves) allow for constant monitoring and analysis of media consumption. The most important issue is the level of energy efficiency that can be displayed on touch panel to be visible for end-user for motivating make savings and set alarms of over limit energy consumption.

Building KNX modular components and setup after finishing installation work gives opportunity to designers to make any decisions on project, how the lights blinds and HVAC will be controlled, whether individually or in any groups.

Designer needs only define architectural space plan, which will be most convenient control of building functions. KNX multifunction buttons. In one module provides control of lighting, blinds, temperature.

Phase I – Design

1. Selection of equipment of functions and drawing a wiring diagram and a view of the switchgear with mounted devices:
 - Switching, Dimming and Blind control – blind/switch actuator for independent control of up to 8 blind/roller shutter drives or for switching up to 16 loads via make contact
 - Switching / dimming lights. KNX DALI gateway REG-K/1/16(64)/64/IP1 supports the switching and dimming of up to 64 EBs in 16 groups and the control up to 16 scenes.
 - The buttons / sensors – KNX push buttons (1-gang, 2-gang, and 4-gang), KNX Basic weather station, presence detector for simultaneously controlling sources of lighting and blinds.
 - The measurement of energy consumption - measuring gate, compatible with Modbus protocol and KNX - Energy meter.
 - Remote access to system functions from your phone or tablet - Wi- Fi InSideControl gateway.

2. Drawing the KNX architectural project for individual rooms.
3. Button symbols. Draw the KNX bus topology, which power supply and communication of all KNX components.

Phase II - Wiring

All electrical circuits (lighting, blinds, etc.) Are connected to the connection box, where they are connected to the KNX actuators. For all the buttons / sensors KNX is carried out by KNX twisted pair cable. While wiring we should try to avoid closed loop connection, recommended to use star and tree topology. KNX cable must be connected to device red and black boxes.

Phase III - assembly devices

Actuators - KNX actuators are usually installed in switchgears with modular apparatus and are installed at the production stage, after assembly they can be removed or upgraded.

The buttons / sensors Schneider Electric production are installed in a standard room wall.

Phase IV - System configuration and programming device functions.

For programming KNX device functions is used ETS software, available on the KNX.org. Applications of the devices are available free of charge at the website www.schneider-electric.com after entering the catalogue number into a search engine unit.

Energy savings

Lighting control:

1. Automatic light switching by motion, after motion is detected and turn off after a set time (corridor, bathrooms, toilets).
2. Reduce light intensity using the dimmer (kitchen). The economic benefits using motion sensors, presence and dimmers can reach up to 30% of the cost of lighting. By reducing the voltage with 10% doubles the life of the bulbs.

Blind control:

Energy savings through improved thermal insulation during cold weather. Obtaining solar energy from windows during winter into the building by raising up the blinds.

6.2. Lighting control

Switch actuator features

- Delays, staircase features
- Blocking
- Logic / priority control
- Scene
- Central control

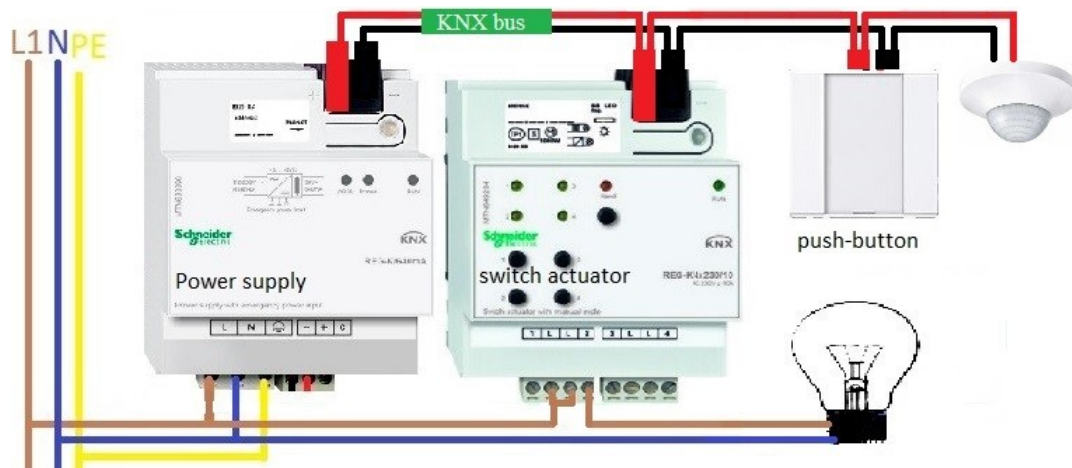

Figure 28. Lighting control.

Power supply

MTN683890 KNX power supply REG-K/640 mA with emergency power input.

It's used for generating the bus voltage for a line with up to 64 bus devices. The emergency power supply REG can be connected in order to buffer the bus voltage.

With integrated choke to decouple the power supply from the bus and a push-button to disconnect the power and reset the bus devices connected to the line. For installation on DIN rails EN 60715.

- Main voltage: AC 110 - 230 V, 50-60 Hz
- Output voltage: 30 V
- Output current: 640 mA

Switch actuator

MTN649204 Switch actuator REG-K/4x230/10 with manual mode.

For independent switching of up to 4 loads via make contacts. The function of the switching channels is freely configurable. All switching outlets can be operated manually using push-button operation.

With integrated bus coupler. For installation on DIN rail EN 50022.

- Main voltage: AC 230 V
- Nominal current: 10A
- Incandescent lamps: 2000 W
- Halogen lamps: 1700 W

Presence detector

MTN630919 KNX ARGUS Presence with light control and IR receiver.

This function watches over a room. A signal is immediately sent out as soon as the presence of a person is reliably detected and also as soon as presence stops being detected. This watchdog function can, for example, be inhibited during the day and only enabled at night for a specific duration as well as over the weekend. If KNX ARGUS Presence detects smaller movements in the room, data telegrams are trans-mitted via KNX to control the lighting, blind or heating at the same time.

- Light sensor: 10-2000 Lux
- Angle of detection: 360°
- Range: a radius of max. 7m (at a mounting height of 2.50m)
- Number of levels: 6
- Number of zones: 136 with 544 switching segments
- Number of movement sensors: 4, separately adjustable
- Number of IR channels: 10 for controlling KNX devices, 10 for configuration.

Push button

With integrated bus coupling unit. Push-button with 2 operating buttons, operating and status display and labelling field. The operating display can also be used as an orientation light. The device is connected to the bus line with a bus connecting terminal.

Switching, toggling, dimming (single/dual-surface), blind (single/dual-surface), pulse edges trigger 1-, 2-, 4- or 8-bit telegrams (distinction between short and long operation), pulse edges with 2-byte telegrams (distinction between short and long operation), 8-bit linear regulator, scene retrieval, scene saving, disable functions.

In ETS5 can be made light control project using presence detector to reduce energy consumption, lights will be switched on when room is used as soon as inhabitant leaves the room lights are switched off, that function guaranties efficient usage of energy and power losses.

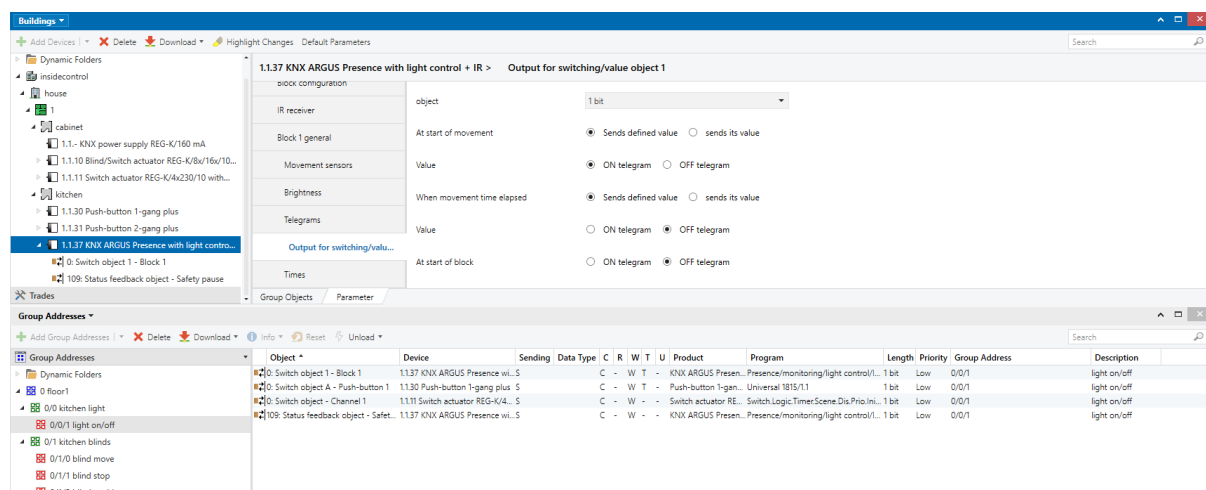

Figure 29. Light control project with presence detector in ETS5.

DALI gateway features

- Configuration using the buttons, KNX, IP
- Switching, dimming and value object per group or EB
- Staircase timer function, status objects, delays
- Scenes, sequences and effects
- Recognition of failure of individual lamps

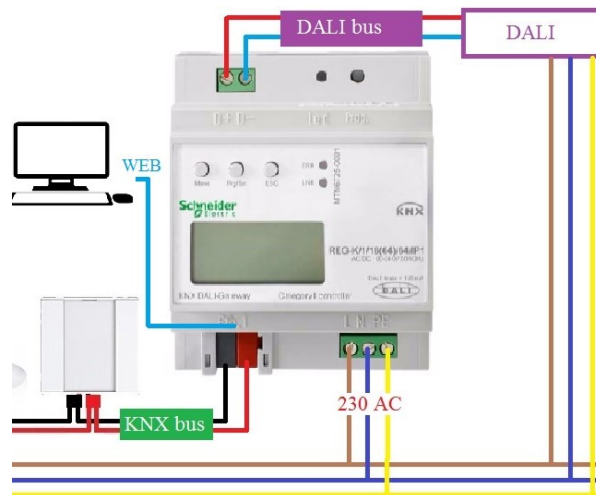

Figure 30. DALI gateway connection

DALI gateway

KNX DALI gateway REG-K/1/16(64)/64/IP1.

The KNX DALI gateway connects KNX to the DALI bus. The gateway is a category I control device with an integrated DALI power supply for the EBs.

It supports the switching and dimming of up to 64 EBs (electronic ballasts) in 16 groups and the control up to 16 scenes. The 64 EBs can be controlled individually or in groups. Error messages of individual EBs or each connected lamp can be transmitted to the KNX and visualised.

- Supply voltage: AC/DC 100-240 V, 50/60 Hz
- Outputs: DALI D+, D-, DC 16-18 V
- Interfaces: KNX, Ethernet RJ-45, DALI.



Figure 31. DALI ballast.

DALI commissioning

The following chart shows the general procedure:

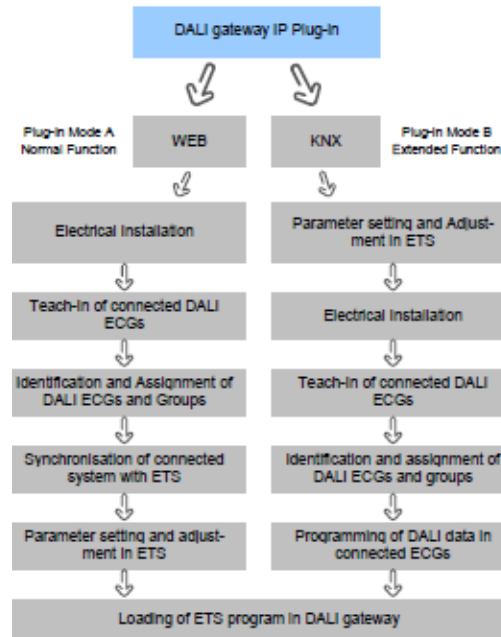

Figure 32. DALI commissioning 2 different ways. [28]

Plug-in

The application for the gateway is based on a powerful KNX communications stack of the System-B type. It is designed as plug-in for ETS-3 and ETS-4. The plug-in design means that an additional installation process is necessary. [28]

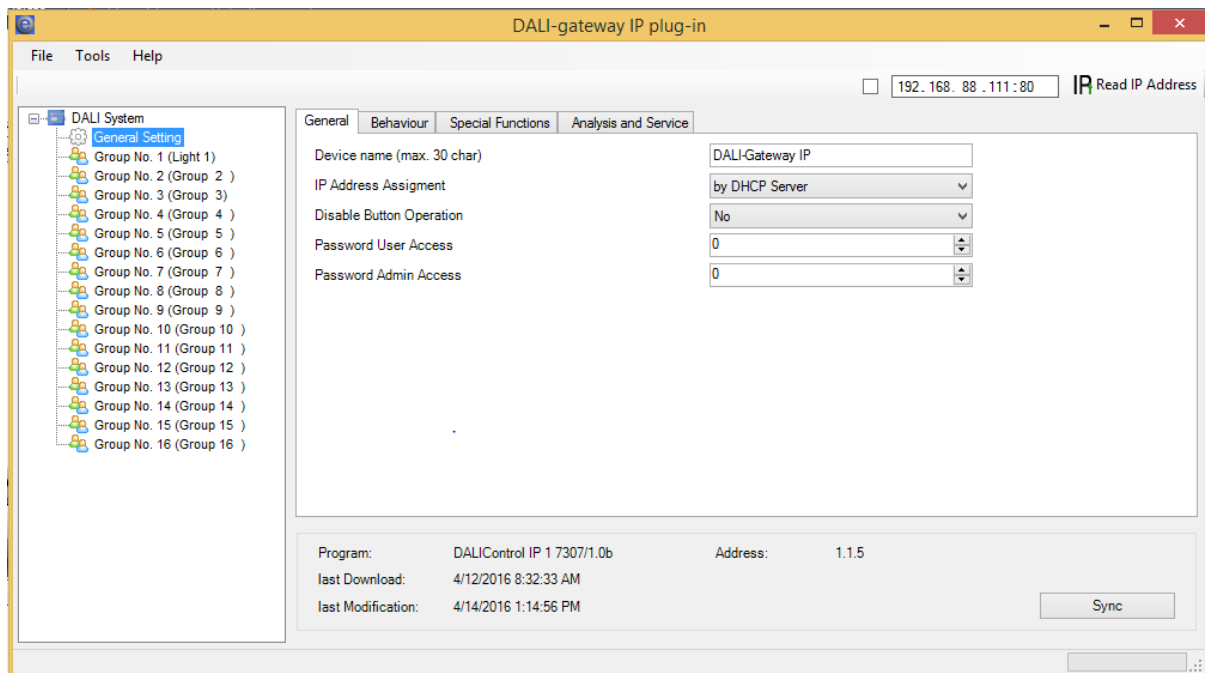

Figure 33. DALI Plug-in.

Control via web browser

Connection see Figure 30

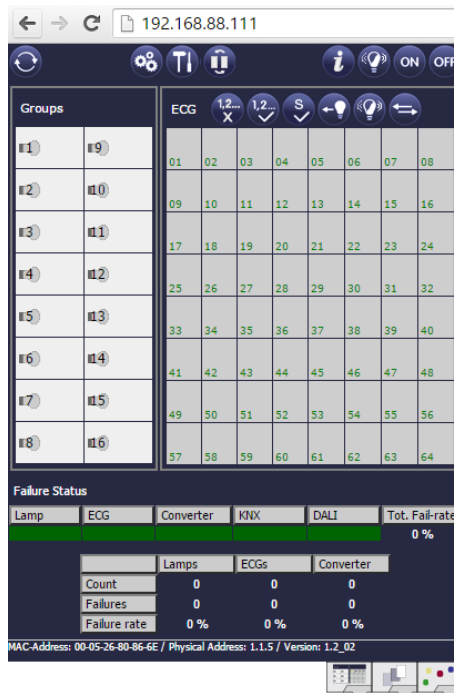

Figure 34. View in Web address.



Figure 35. DALI IP address.

6.3. Blinds control

Blind actuator features

- ON: On, Off, information about the status, delays, logic operations
- Blinds: up, down, stop, position information about slats current position
- Automatic test kind of attached load

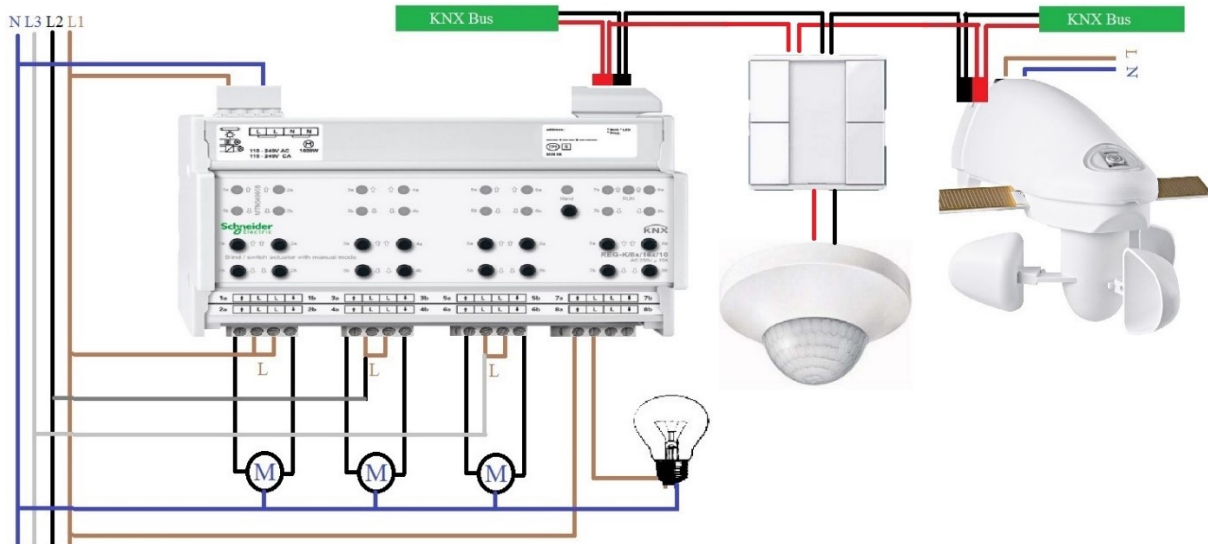

Figure 36. Blinds control.

Blind actuator

MTN649908 blind/switch actuator REG-K/8x/16x/10 with manual mode.

For independent control of up to 8 blind/roller shutter drives or for switching up to 16 loads via make contacts. The function of the blind or switching channels is freely configurable. All blind/switch outputs can be operated manually using push-buttons. With integrated bus coupling unit. For installation on DIN rails EN 500.

Control by manual operation via objects and manual mode via the push-buttons of the actuator. Operation as break contact/make contact. Programmable behaviour for download. Delay functions for each channel. Staircase lighting function with/without manual OFF function. Weather alarm functions: wind alarm, rain alarm, Behaviour at start/end of the weather alarm.

- Nominal voltage: AC 230 V, 50 - 60 H

For each blind output:

- Nominal current: 10 A,
- Motor load: AC 230 V, max. 1000 W

For each switch output:

- Nominal current: 10 A,
- Incandescent lamps: AC 230 V, max. 2000 W
- Halogen lamps: AC 230 V, max. 1700 W

Blind settings

These functions allow you to commission the device and equip it with simple functionality

- Defining blind type
- Move height positions and slat opening angle manually

Advanced functions

- Move height position and slat opening angle using absolute position commands
- Calibration/Reference movement
- Scene function

Switching settings

Basic function

- Switching outputs

Advanced functions

- Central function
- Time function (on/off delay, staircase lighting function)
- Scene function

Weather station

MTN663990 KNX Basic weather station.

The KNX Basic weather station records weather data, analysis these and can transmit them to the bus.

The device has a wind sensor, precipitation sensor, temperature sensor and brightness sensor.

- Wind, brightness and temperature are each sent as a 2-byte value, rain as 1-byte. Wind can be sent either in m/s or km/h.
- 4 universal channels for single tasks or logic operations. Four logic functions per channel are possible.
- 3 sun protection channels for external blinds/roller shutter control.
- Power supply: AC 230 V
- Power consumption: max. 10 mA with bus voltage
- Power consumption: 10 W with heating
- Sensors: 4
- Measuring range: - 20°C to +55°C
- Brightness range: 1 to 100,000 lux
- Angle of detection: 150°.

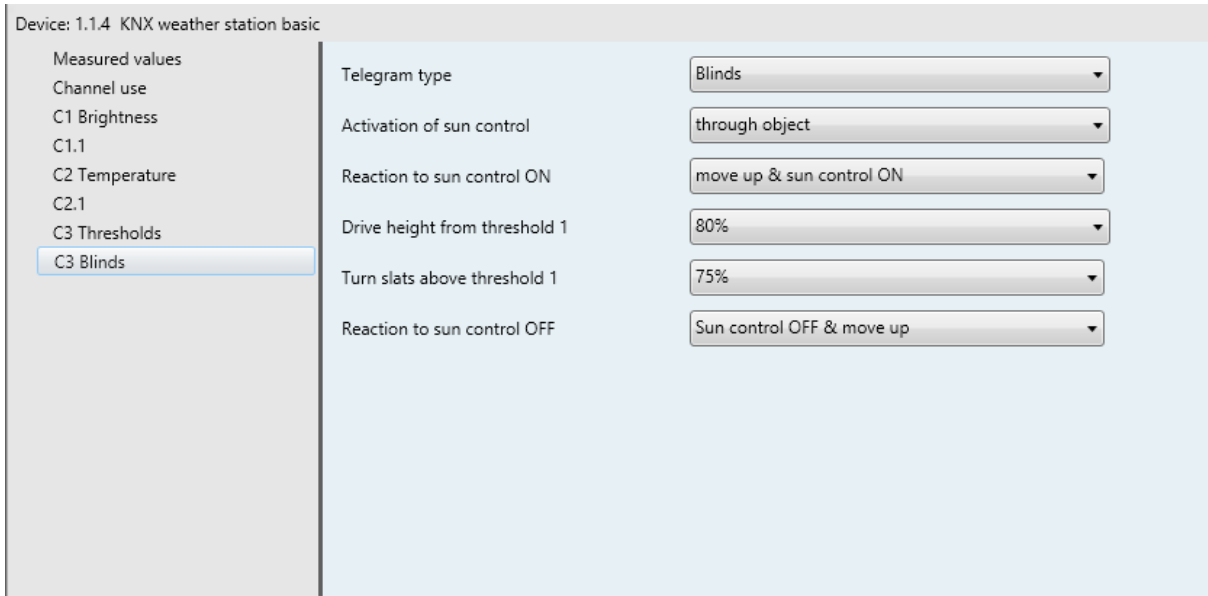

Figure 37. KNX weather station. ETS4 Blind control.

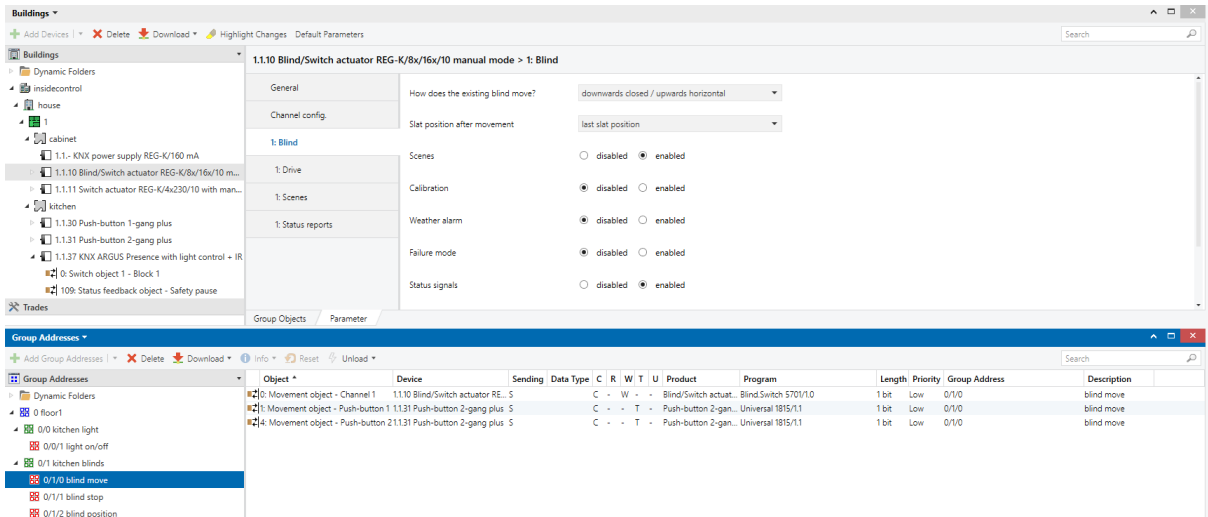

Figure 38. Blinds control project in ETS5.

6.4. Comfort control

Fan-coil actuator features

- Automatic / Manual control of fan drives and valves
- 16A relay (C1) general purpose
- 2 inputs (E1, E2) - window contact, temperature or rain sensor
- Periodic additional ventilation

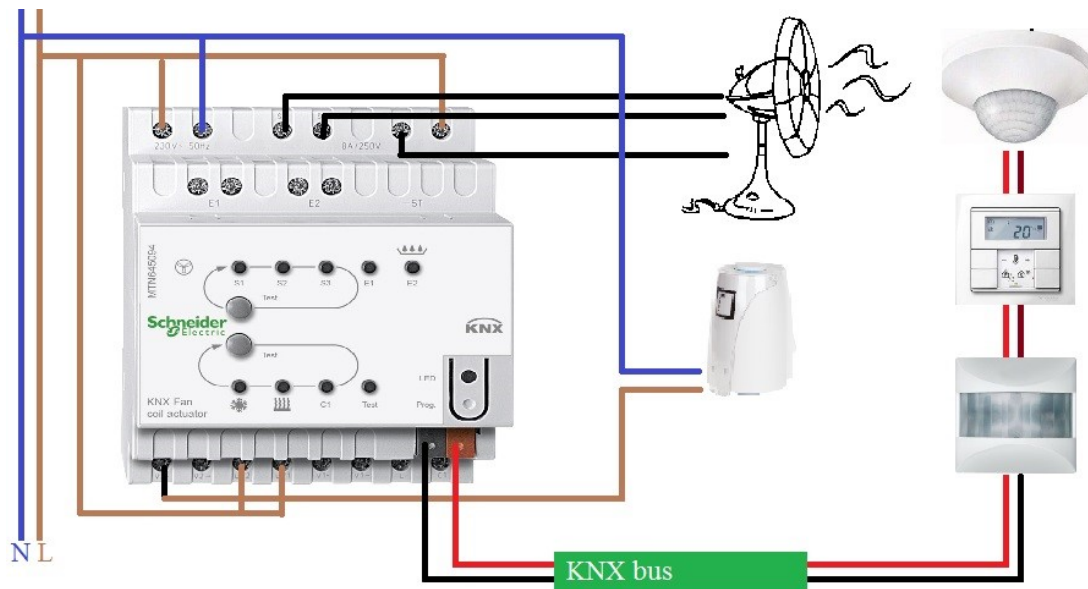

Figure 39. Fan-coil control.

Fan coil actuator

MTN645094 KNX Fan coil actuator REG-K.

For heating, ventilation and air conditioning control. For controlling fan convectors with up to three speeds, as well as for controlling three-step motor drives (continuous/pulse-width-modulated) or two-step thermal drives. The actuator supports 2-pipe and 4-pipe systems.

Two floating binary inputs for window contact and level contact for condensed water container, for example. Connection of 1-speed to 3-speed fans. The multi-function push-button with room temperature control can be used to activate the fan coil actuator. With integrated bus coupler. For installation on DIN rails EN 6071

- Power supply: AC 230 V $\pm 10\%$, 50/60 Hz
- Power consumption: max. 3 VA
- Outputs: 3 floating contacts (fan coil), 2 semi-conductor switches (valve connections)
- Additional relay switching capacity: 16 A
- Fan relay switching capacity: 8 A
- Inputs: 2, max. Cable length 5 m

Movement detector

MTN631619 KNX ARGUS 180, flush-mounted.

For System M. Movement detector for indoors. When a movement is detected, a data telegram defined by the programming is transmitter. With integrated bus coupling unit.

- Angle of detection: 180°Range: 8 m (for mounting height of 1.1 m)
- Number of levels: 1
- Number of zones: 14
- Sensitivity: infinitely adjustable (ETS or potentiometer)
- Light sensor: infinitely adjustable from approx. 10 to 2000 Lux (ETS or potentiometer)
- Time: adjustable in steps from 1 s to 8 mi

Push-button

MTN6212-0325 Push-button 2-gng plus with room temp. Ctrl unit.

For System M. Convenient control unit with 4 operating buttons, operating and status display and labelling field. The operating display can also be used as an orientation light. With room temperature control unit and display. With 5 red LEDs.

The room temperature control unit can be used for heating and cooling with infinitely adjustable KNX valve drives or to trigger switch actuators and heating actuators.

Controller mode:

- Heating with one controller output
- Cooling with one controller output
- Heating and cooling with separate controller outputs
- Heating and cooling with one controller output
- 2-step heating with 2 control outputs
- 2-step cooling with 2 control outputs
- 2-step heating and cooling with 4 control outputs

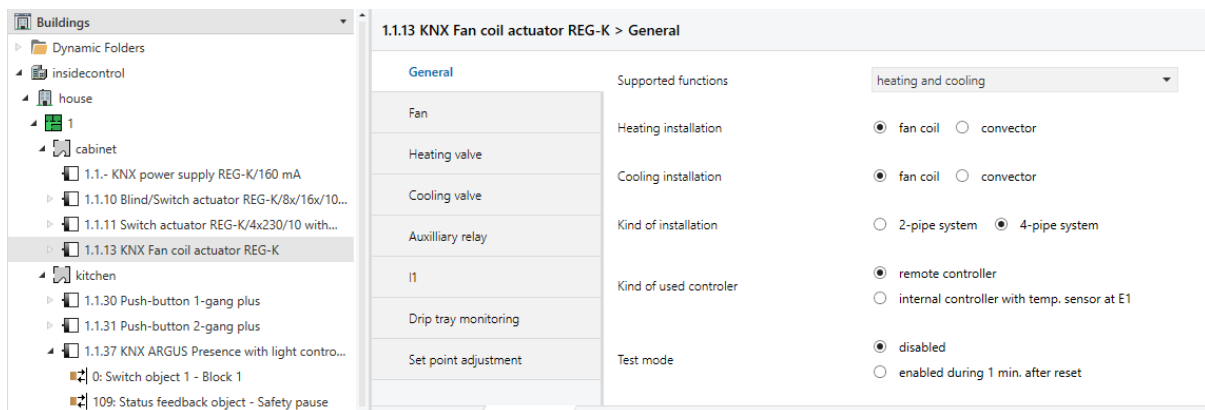

Figure 40. Fan-coil control project in ETS5.

6.5. Energy management

KNX Energy meter features

- Current, Power, Energy consumption measurement.
- Energy management, Alarm threshold, Adjustable tolerance functions.
- Power measurement accuracy: 10%

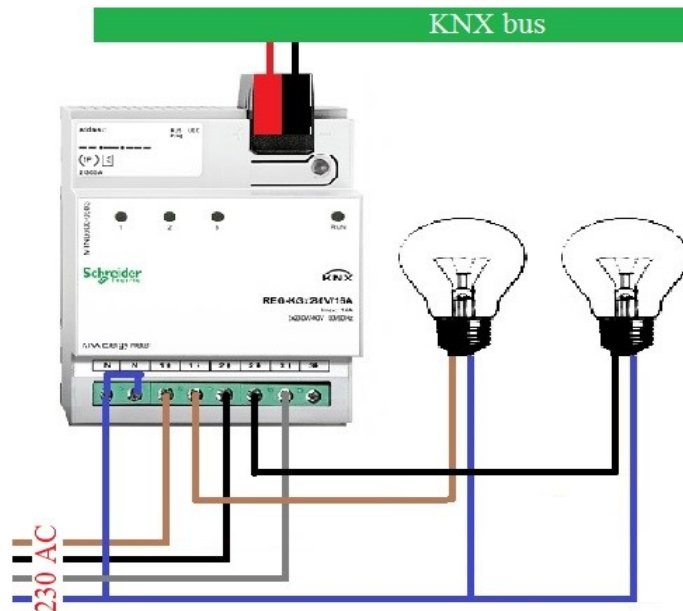

Figure 41. Merten Energy meter.

KNX Energy meter

MTN6600-0603 Merten KNX - Energy meter - 3 x 230 V - 16 A.

Monitor and measure energy on the channels connected, which increases building energy efficiency.

- Measurement of: energy consumption, power and current and providing the results via the bus.
- Determining the active energy consumption per channel and the total consumption.
- Measuring the active energy consumption per channel: max. 1.5%
- Accuracy of power measurement: 10%
- For installation on TH35 DIN rails as per DIN EN 60715.
- The bus connection is carried out via a bus connecting terminal.

Technical data

- Supply voltage: via KNX bus, DC 24 V, max. 12.5 mA

Inputs:

- Voltage: AC 220/230 V, 50/60 Hz
- Max. load per channel: 16 A
- Current: 20 mA (power factor 1)
- External protection per channel: 16 A

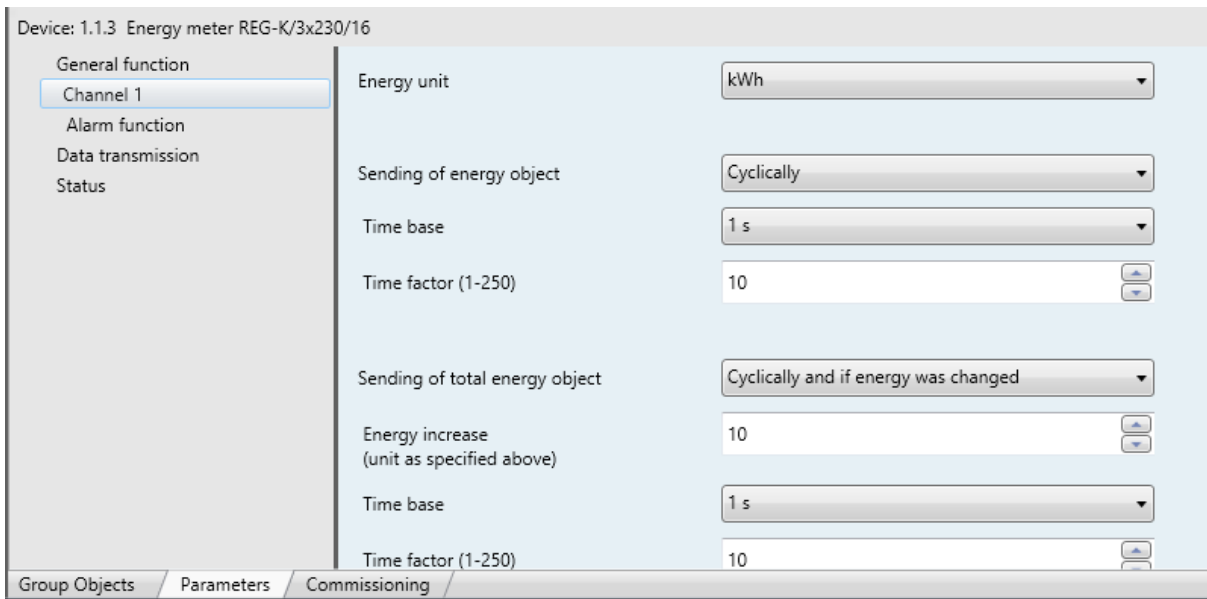

Figure 42. KNX energy meter parameters in ETS4.

Modbus energy metering Features

- Measurement of voltage, current, frequency, power factor, active power, reactive and apparent power, binary and analog values
- 17 predefined templates for meters
- 40 registers for other devices
- Diagnostics

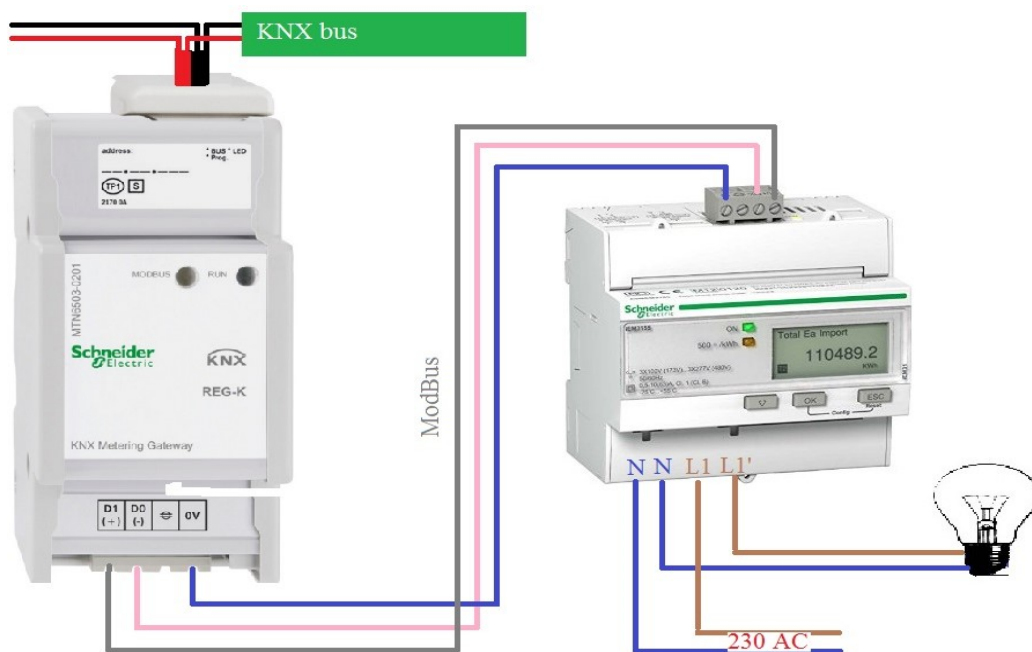

Figure 43. Metering gateway.

Energy gateway

MTN6503-0201 KNX Metering Gateway Modbus REG-K.

The KNX Metering Gateway Modbus REG-K is a gateway between a Modbus installation and the KNX bus. The device transmits measured power and consumption values from connected Modbus power counters to the KNX bus. These power counter data can be used to evaluate, visualise, or reduce the power consumption in your KNX installation.

The device is supplied with power via the KNX bus. With integrated bus coupling unit. For installation on TH35 DIN rails as per DIN EN 60715. The bus connection is carried out via a bus terminal.

The following models of Schneider Electric Modbus counters are supported:

- PM9C, PM210 universal meter
- PM710, PM750 universal meters
- iEM3150, iEM3155, iEM3250, iEM3255 energy counter.

Modbus communication settings (baud rate, parity, delays). Selection of pre-programmed templates for 17 Modbus counters with detection of: voltage (phase 1-3), current (phase 1-3), frequency, power factor, active power, reactive power, apparent power, active energy, reactive energy.

Modbus Energy Meter

A9MEM3155 Schneider IEM3155 3-Phase 63A direct connection Din Modbus Energy Meter MID.

A multi-tariff meter controlled by digital input or internal clock, MID certified. Energy meter, four quadrant, multi-tariffs with partial counter and current, voltage, power measurement. Modbus communication, digital input/output and MID certified. Includes internal real-time clock, pulse input, alarm, MID registering and Modbus RS485 comm port (Modbus as standard)

Innovative design makes the meters smart and simple:

- Easy to install for panel builders
 - Easy to commission for contractors and installers
 - Easy to operate for end user
-
- Measured Voltage- Wye: 100-277 V L-N, 173-480V V L-L 20% Delta: 173-480 V L-L 20%
 - Maximum current- 63A
 - Measured current-0.5A to 63A
 - Overload-332 V L-N or 575 V L-L
 - Voltage impedance- 0.3 mW
 - Current impedance-<0.3 mW

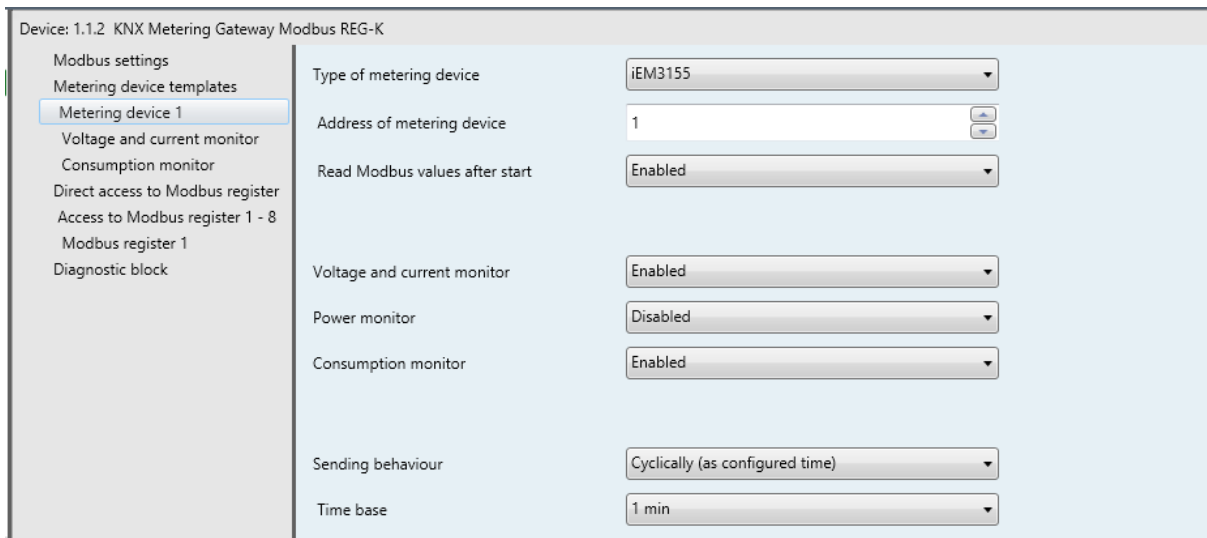

Figure 44. Energy meter. Modbus connection in ETS4.

Conclusion

Each KWh used by loads are sent from the energy meter to the KNX binary input as number of pulses. Consumption data is then transferred to mobile and PC, where it can be viewed and checked. SCADA can also be used to view and control current building states and functions.

Applications:

- Integration meters with Modbus interface to KNX
- measurements and visualization of electricity, water and gas
- management and optimize the use of electrical energy costs

Benefits:

- Reduce energy consumption by up to 10% and more: as displayed values encourages end user to reduce energy consumption.
- Increase safety by automating alarms and emergency calls
- flexible remote monitoring and control

6.6. Remote control and supervision

IP-Gateway features

- Control: lighting, RGB LED lights, blinds, heating, scenes
- Visualization of information: temperature, humidity, wind, light intensity, flooding, fire, gas.
- Checking current, voltage and power current

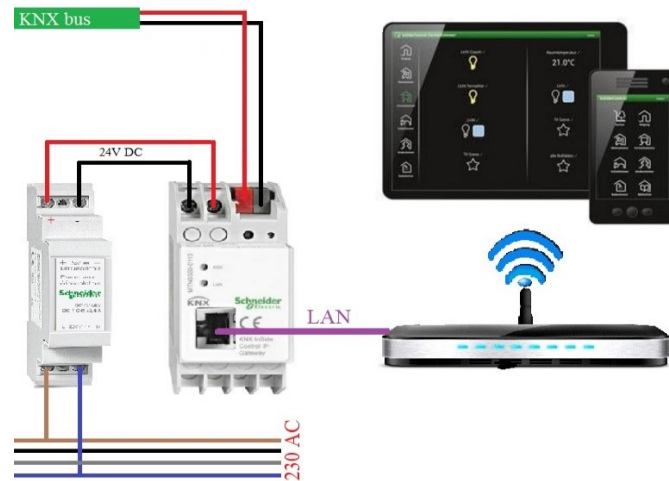

Figure 45. InSideControl, IP gateway.

InSideControl IP-Gateway

MTN6500-0113 KNX InSideControl IP-Gateway.

The KNX InSideControl IP gateway connects the KNX installation with the IP network (LAN). In combination with the applications “InSideControl App/HD App”, the KNX installation can be controlled with up to 5 smartphones or tablet PCs simultaneously.

The gateway supports the internet protocol DHCP. The IP address can be assigned dynamically via a DHCP server or manually via ETS settings. The gateway operates in accordance with the KNXnet/IP specification using Core, device management and tunnelling.

The gateway can additionally serve as a programming interface in order to connect a PC with the KNX bus (e.g. for ETS programming with suitable ETS).

With integrated bus coupling unit. For installation on TH35 DIN rails as per DIN EN 60715. The bus connection is carried out via a bus connecting terminal.

- Operational voltage: 24V
- Device application: Lighting, Blind and Heating.
- Control type: 5 Smartphones or tablet PC
- Software type: InSideControl App/HD App
- Communication network type: EthernetRJ45

Power supply

MTN693003 Power supply REG, 24 V DC / 0.4 A.

Power supply for 24 V binary inputs. With integrated overload and short-circuit protection. For installation on DIN rails TH35 according to EN 60715

- Primary supply: AC 230 V, 48-63 Hz
- Output voltage: 24V

- Output current: 0.4A
- Output power: 10 W

6.7. Local control and monitoring

Touch panel features

- Password protection of selected functions
- Presence simulation, scenes
- Weekly timer

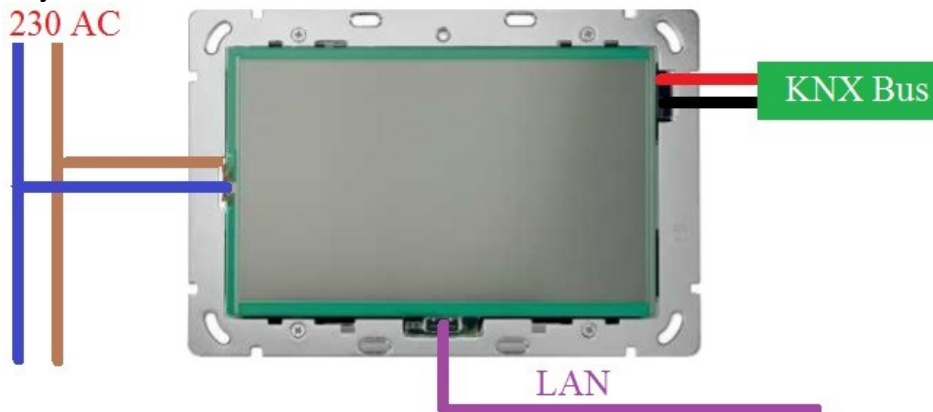

Figure 46. Touch Panel 7".

Touch Panel 7"

MTN6260-1007 Touch Panel 7".

The Touch Panel 7" is used for the visualisation and control of current building states and functions. The integrated visualisation software with the self-explanatory user interface offers a high level of operating convenience when operating the touch-sensitive TFT display with LED background lighting.

- Presence simulation (recording and play-back of switching habits)
 - Alarm management, Internet access
 - Password protection, Adjustable user interface
 - Integrated room temperature controller (measurement and control)
 - LAN programming directly from the ETS Plugin
- Nominal voltage: AC 230 V, 50 Hz
 - Power consumption: 4.3 W in energy-saving mode, 8 W when in operation
 - Ambient operating temperature: -5°C to 45 °C

6.8. spaceLYnk

spaceLYnk is the new logic controller from Schneider Electric, which allows to connect different standards and protocols for home automation and energy metering.

Beyond that, it provides an outstanding, comfort-able user interface. spaceLYnk offers a comprehensive and distinguished solution and achieves real differentiation as well as added value to you and your customers.

The installation of the spaceLYnk is easy and efficient. It has a compact, ergonomic size and is mounted on DIN rail. No screw is needed for wiring, and pre-programming is possible, which saves labour time on site.

Gateway

As gateway, it allows communication and interoperation of different building control products and functions like lighting, blinds and heating.

User interface

As user interface – based on a web server application – all functions can be controlled and be displayed on local and mobile devices such as tablet PCs or smartphones.

Memory function

spaceLYnk is able to display measurement of gas, water and electricity and monitors the consumption on a daily, monthly and yearly basis.

Event controller

And finally as an event controller, which sends a notification/message in case of any failure or issue.

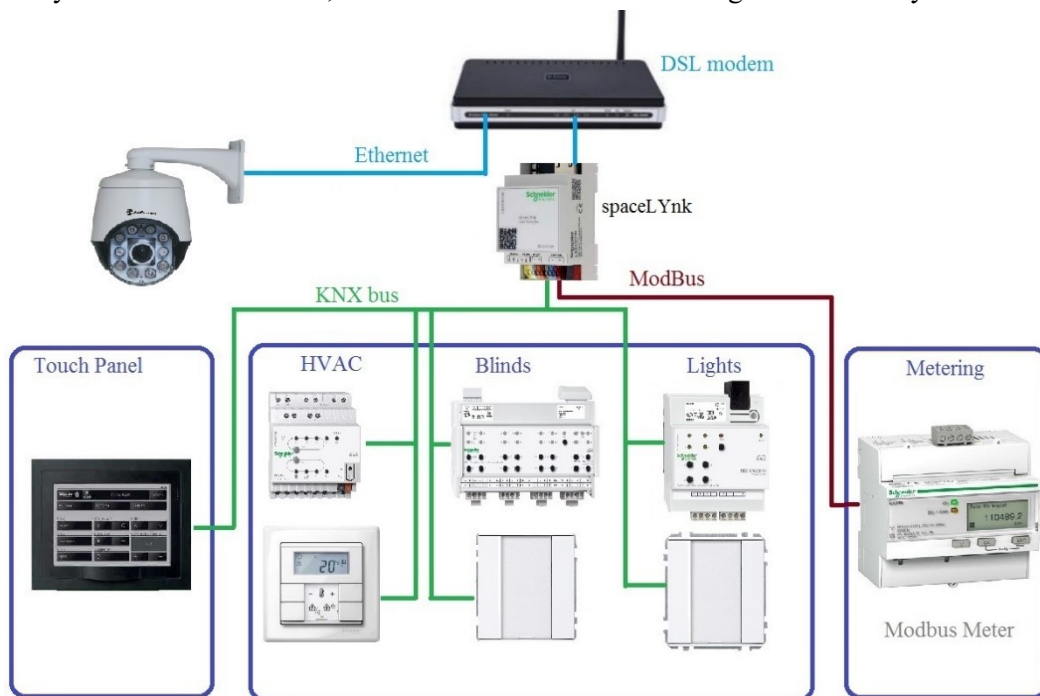
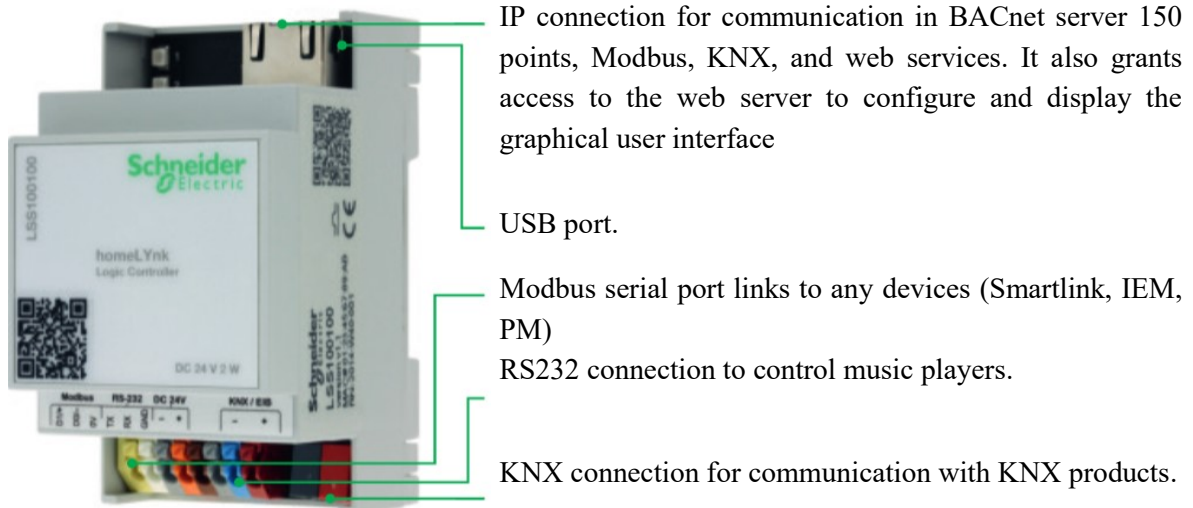

Figure 47. spaceLYnk Standards and protocols compatibility.

LSS100200 spaceLYnk Logic controller.

The spacelynk is the easiest way to visualise and program complex logic in KNX and Modbus networks.

Table 5. spaceLYnk communication ports.



Applications:

- Logical functions
- WEB SCADA visualization for PC and touch-devices
- Cross-standard gateway between KNX and Modbus RTU/TCP
- BACnet Server
- Integration with third party devices over RS-232 (IR, AV)
- Scheduling
- Camera streaming
- Data logger with trend

Visualisation

- Fast multilevel visualisation creation and processing in few steps by freely uploading background image file and adding objects.
- Visualisation and icons made for all control devices. spaceLYnk provides a selection of icons and templates, but an own library can easily be included as well with a one click import of a zip file.
- Schedulers simple to be created, integrated in a page or directly displayed on the schedulers view. Possibility to program an event and modify values.
- Trend logs simple to create. Can be integrated in a page or directly display on the trends view.



Figure 48. Mobile Laboratory with KNX devices.

Consumed energy by the Mobile laboratory is 10Wh. Which is 87.6KWh per one year. According Czech Republic electricity cost it's about 438czk per year.

Table 6. KNX devices energy usage.

MTN6725-000	KNX DALI gateway	1.1.5	Total Energy consumption 10Wh
MTN683890	KNX power supply		
MTN6600-0603	Energy meter REG-K/3x230/16	1.1.3	
MTN6503-0201	KNX Metering Gateway Modbus REG-K	1.1.2	
A9MEM3155	Energy meter		
LSS100200	spaceLYnk logic controller		
MTN6500-0113	KNX InSideControl IP-Gateway	1.1.15	
MTN693003	Power supply REG, 24V DC / 0.4A		
MTN663990	KNX weather station basic	1.1.4	

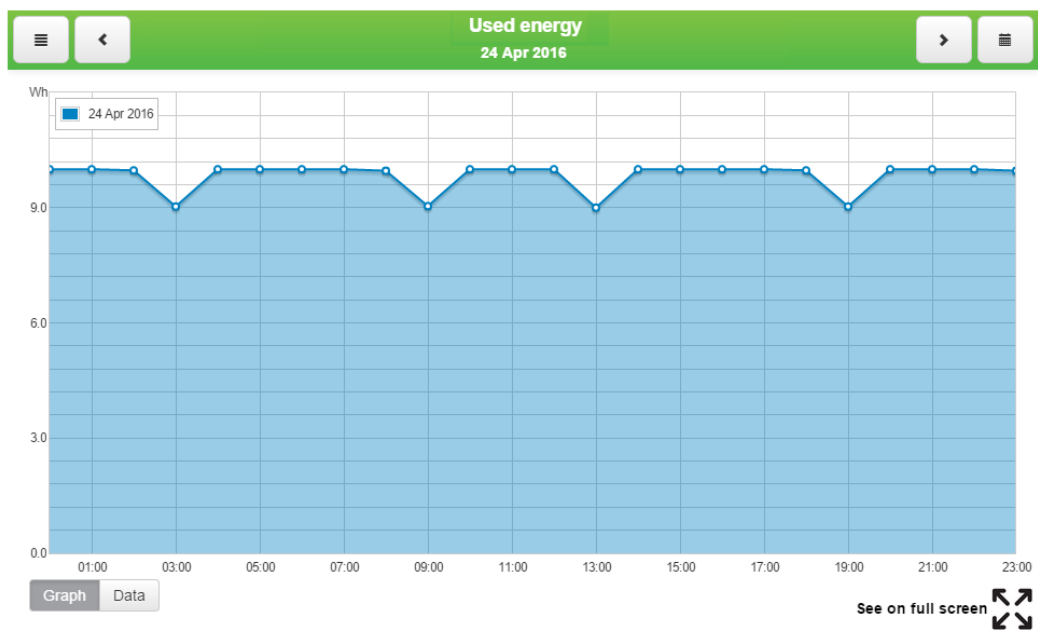

Figure 49. Consumed energy by mobile LAB.

6.9. Wiring diagram of the switchgear

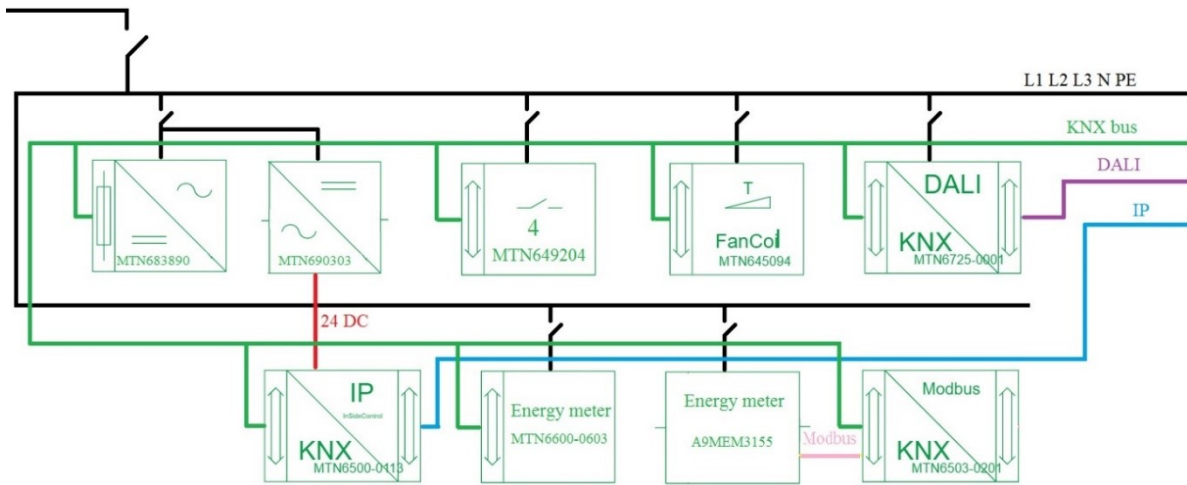

Figure 50. Wiring of switchgear.

6.10. Floor plan with KNX sensors

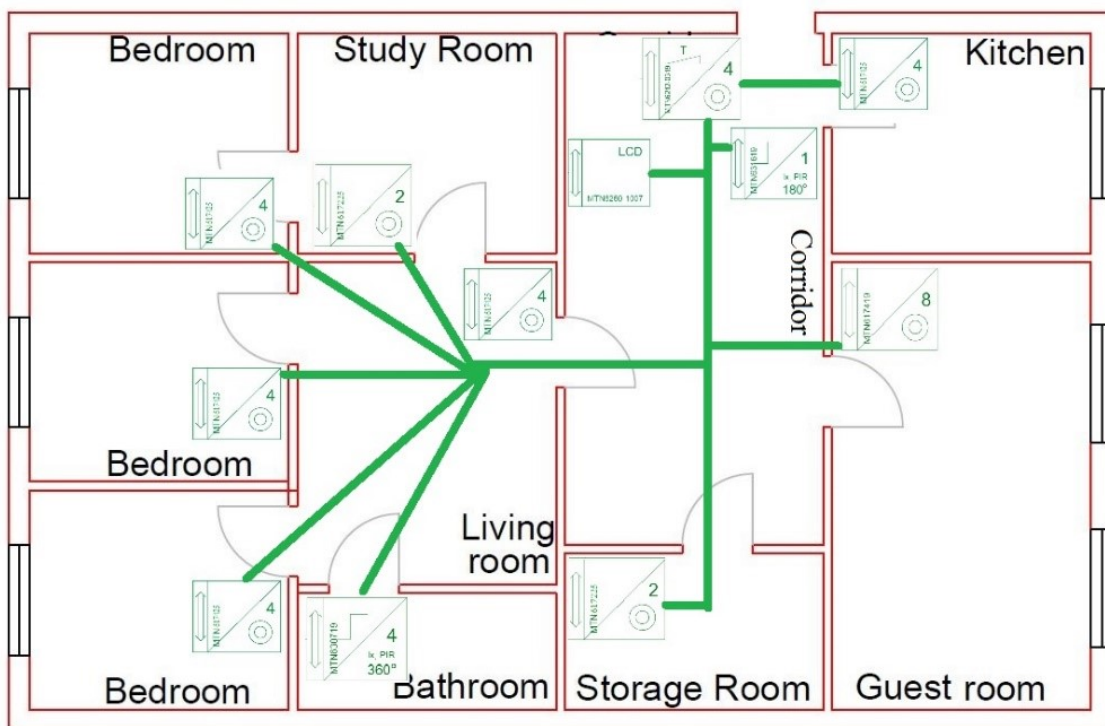

Figure 51. Floor plan with sensors.

6.11. KNX components overview

Table 7. Power supplies



	 MTN683890	€386		 MTN693003	€136
---	--	------	---	--	------

Table 8. Actuators





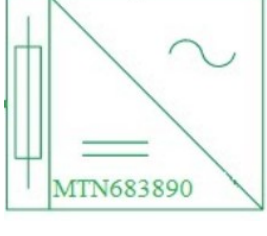

	 MTN649204	€294		 MTN6725-0001	€629
	 MTN649204	€712		 MTN645094	€394

Table 9. System devices

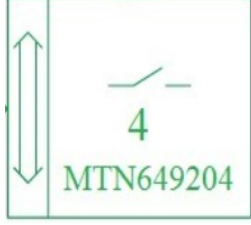

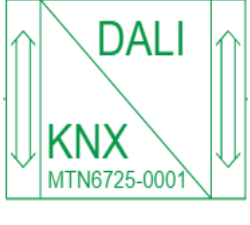

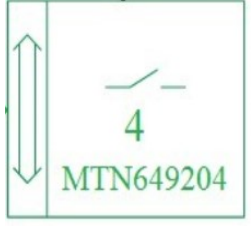

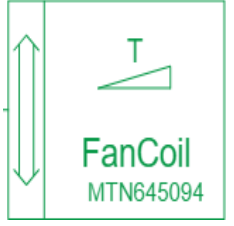



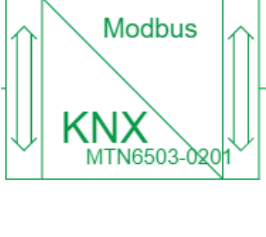

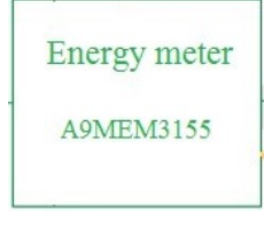

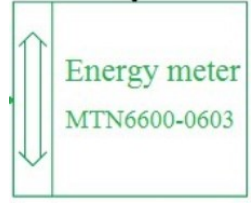

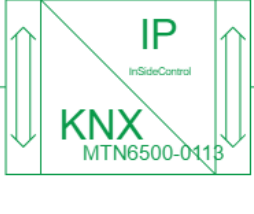

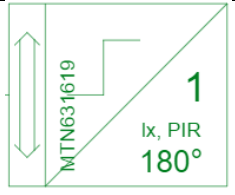

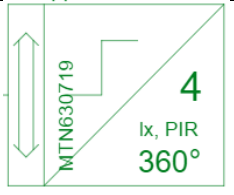

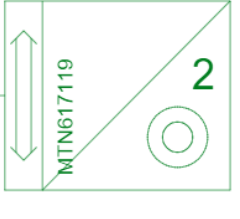
	 MTN6503-0201	€300		 A9MEM3155	€328
	 MTN6600-0603	€202		 MTN6500-0113	€690

Table 10. Sensors

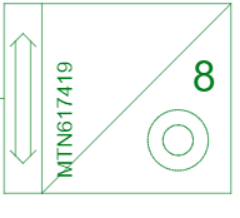
	 MTN631619 1 lx, PIR 180°	€198		 MTN630719 4 lx, PIR 360°	€199
---	--	------	--	--	------

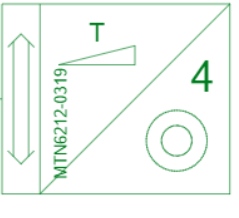
		€133			€151
		Quantity-2			Quantity-5
		€189			€334

		€1,795		€663
	€ 1,690.12			

Total price: €10.000 [29]

Information about components features is taken from [30]

7. Visualization, Mobile control, SCADA

7.1. InSideControl

A KNX installation in a private flat makes it possible to control the lighting, blinds and heating. Also it enables specific energy savings by recording and displaying the consumption of individual devices and rooms.

With InSideControl, you can control your KNX installation and therefore your entire house with a Smart device. For this, the application InSideControl App or InSideControl HDApp must be installed on the portable device. The access to the KNX installation via the portable device takes place either via the local network (WLAN) or via a VPN access.

By the other hand, you can use InSideControl to control lighting, blinds or heating individually or to call up multiple devices at the same time via scenes. Messages from the KNX installation can also be received (e.g. a flood message or energy consumption display).

To allow InSideControl to access your KNX installation, a KNX InSideControl IP gateway must be installed in your KNX installation.

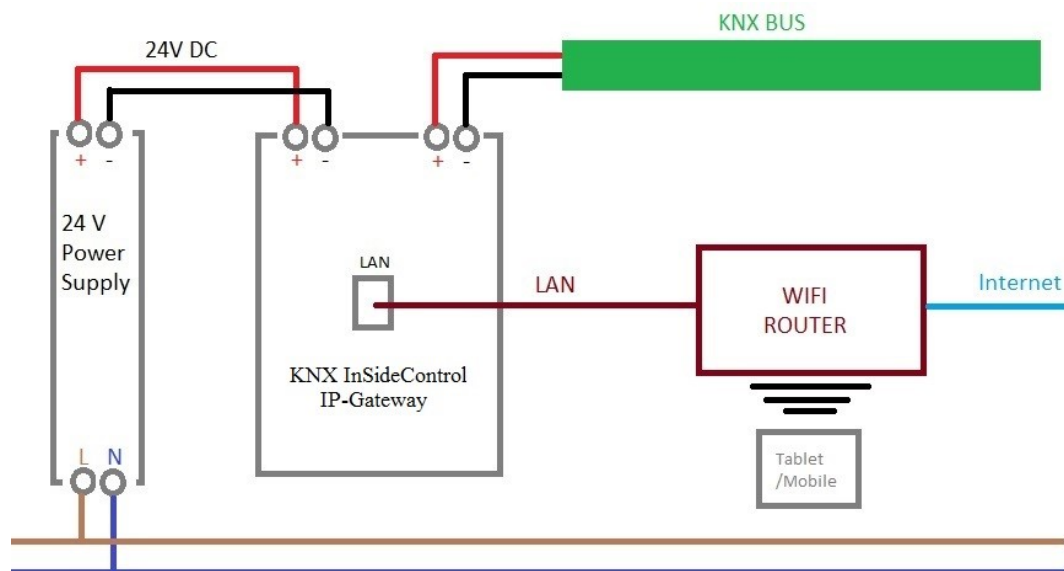

Figure 52. KNX-IP InSideControl control scheme

The following basic steps must be performed in order to be able to use InSideControl:

- InSideControl Builder
 - Download and install Builder
 - Create a project
 - Create a configuration file
- InSideControl App/HDApp
 - Install the App / HD App on the portable devices
- file to portable devices
- Connect portable devices to the IP gateway [31]

The InSideControl Builder represents the connection element between the ETS planning and the App/HD App. You use InSideControl Builder to create the desired functions that are then visualised in the App/HD App. You define rooms/areas, add devices to the rooms and enter the corresponding ETS group addresses from the ETS project.

A comprehensive collection of icons for rooms and devices is provided for visualisation purposes. After finishing the project in Builder you create a configuration file containing all the relevant visualisation data and the information required for connecting to your IP gateway. You then transfer the configuration file to the portable device and connect the portable device to the IP gateway.

Basic procedure for creating a project:

- Create project data
- Add a room
- Add a device
- Configure group addresses
- Export the configuration file. [31]

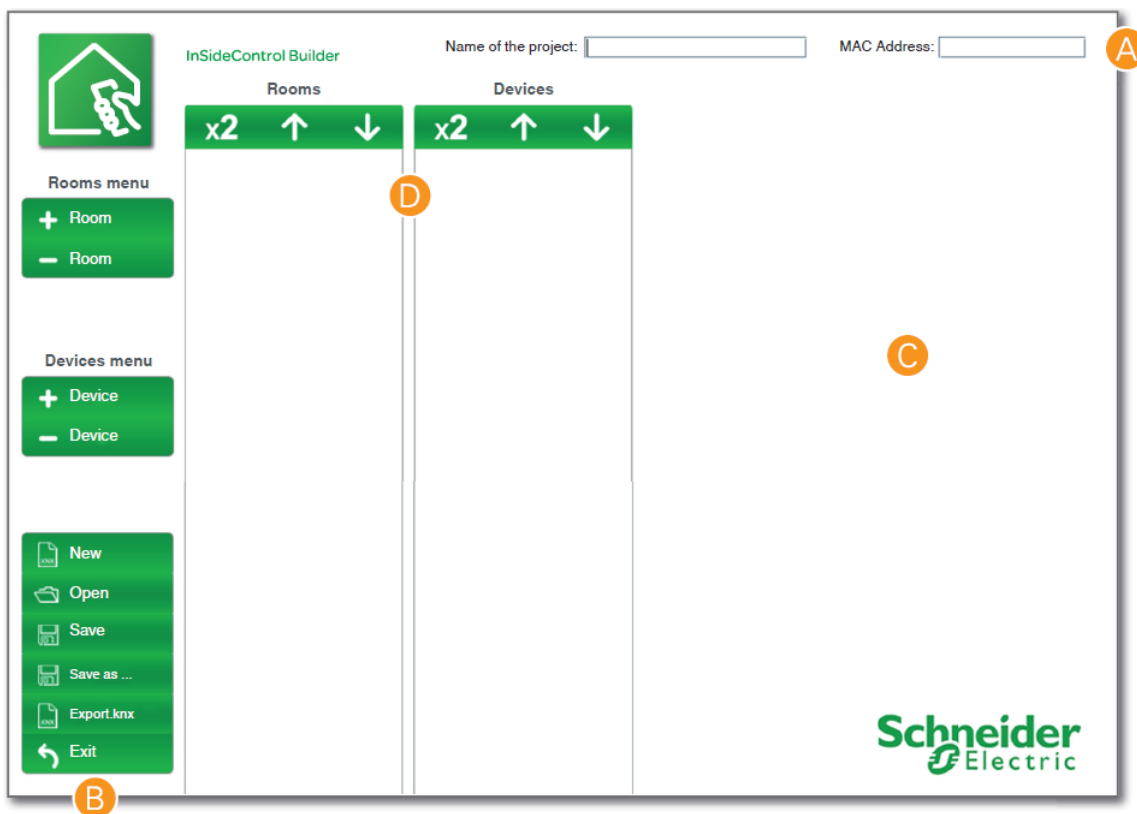

Figure 53. InSideControl Builder structure. [31]

- A. Project data area
- B. Control palette
- C. Configuration area
- D. Display area for rooms and devices

A. Name of the project:

- Enter a descriptive name for the system here. This name is displayed in the status bar of the App/HD App and should not be longer than 12 characters.

B. MAC Address:

- Enter the MAC address of your gateway here, in lowercase and without delimiter characters or spaces (max.12 characters).

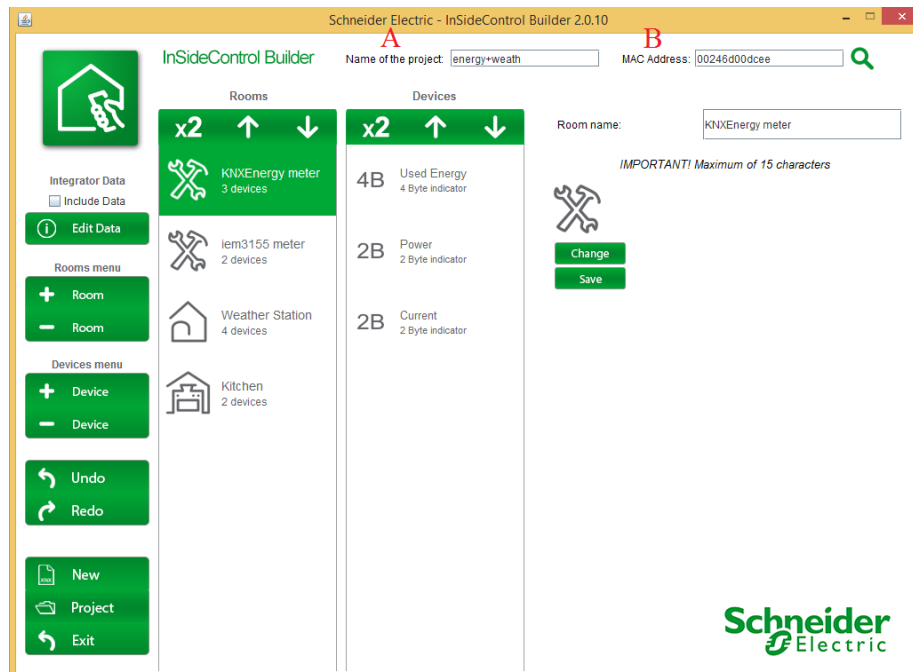

Figure 54. Energy monitoring project for smart phone in InSideControl Builder.

Rooms menu:

- + Room: Add a new room.
- Room: Delete a room and all devices it contains.

Devices menu:

- + Device: Add a new device.
- Device: Delete a device.

Rooms

A room is an area used for grouping various devices (e.g. lamps, blinds, displays, warning notifications). A room must contain at least one device. After adding a room via + Room the following elements are displayed:

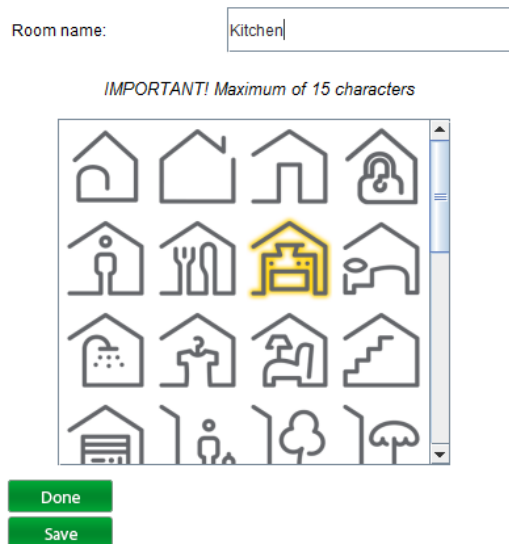

Figure 55. Room menu InSideControl Builder.

Devices

Devices are (e.g.) lamps, blinds, warning notifications or temperature displays. Each device has corresponding group addresses that you adopt from your ETS project. Devices are always assigned to one or more rooms.

After adding a device via + Device the following elements are displayed:

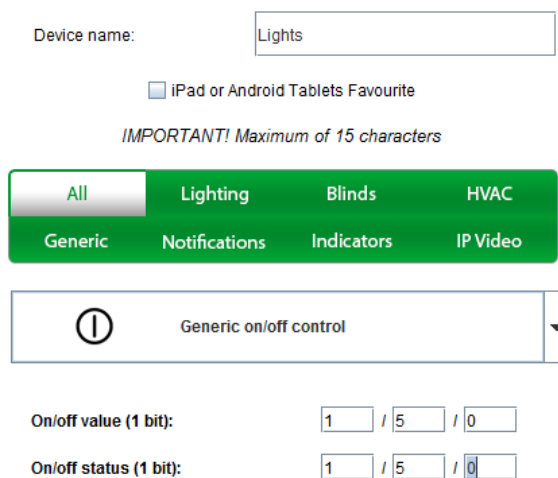

Figure 56. Device menu in InSideControl Builder.

Creating a configuration file

After finishing your project you create the configuration file (Energy_management.knx). The configuration file contains all the relevant data of the KNX installation and the display data for the App/HD App.

You then transfer the configuration file to the portable device.

- 1 Click Export.knx.
- 2 Select the storage location and enter an appropriate file name.
- 3 Click Save.

The Smartphone displays the energy consumption of the each rooms (blinds and lighting). Knowledge of the energy usage makes it possible for user to estimate whether their own energy consumption is high or low. This is the first step in taking control of their energy consumption and providing incentives for reducing usage of energy. Next step is to set threshold values on the KNX Energy Meter, and if they are over the limit then part of the room lighting will be switched off. [32]

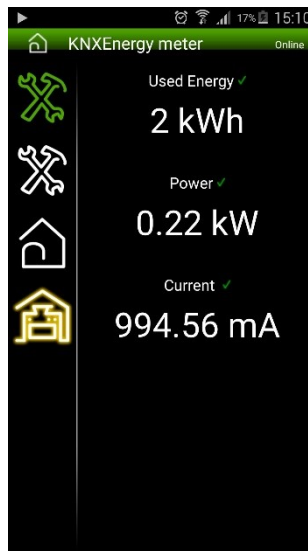

Figure 57. Current energy consumption with InSideControl App.

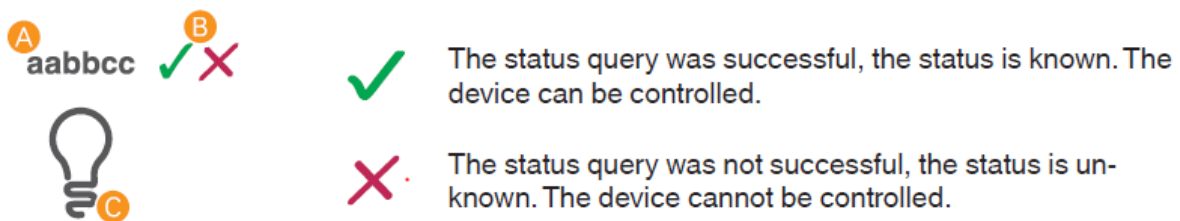

Figure 58. Status query working. [31]

- A. Device name
- B. Result of the status query
- C. Device icon

7.2. AyControl KNX

AyControl KNX visualisation app is used for the IP gateways which doesn't have support from InSideControl.



Figure 59. MTN680329, KNX/IP router.

- Easy to use, high-class money saver.

Forget about old style wall-mounted touch screens and expensive KNX (home) servers! Use ayControl KNX as the economic alternative.

- Safety and remote control.

Keep an eye on your house: Embedding of IP cameras and VoIP intercoms. Control everything from everywhere via cellular and Wi-Fi connections.

- For new and upgraded buildings with KNX bus.

If you don't plan to build a new house, you can upgrade your existing house with a KNX/EIB bus to gain a lot of comfort with ayControl KNX.

- Simple configuration & customized design.

You can easily customize the design of ayControl KNX. Use your own menu and background images to fit your style. Select your favourite theme colour etc.

In laboratory it was used for controlling blinds and lights via mobile phone on MTN680329, KNX/IP router REG-K.

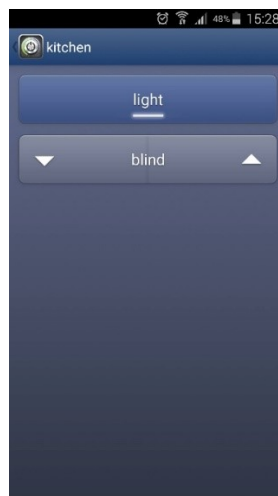

Figure 60. Lights and Blinds control in ayControl App.

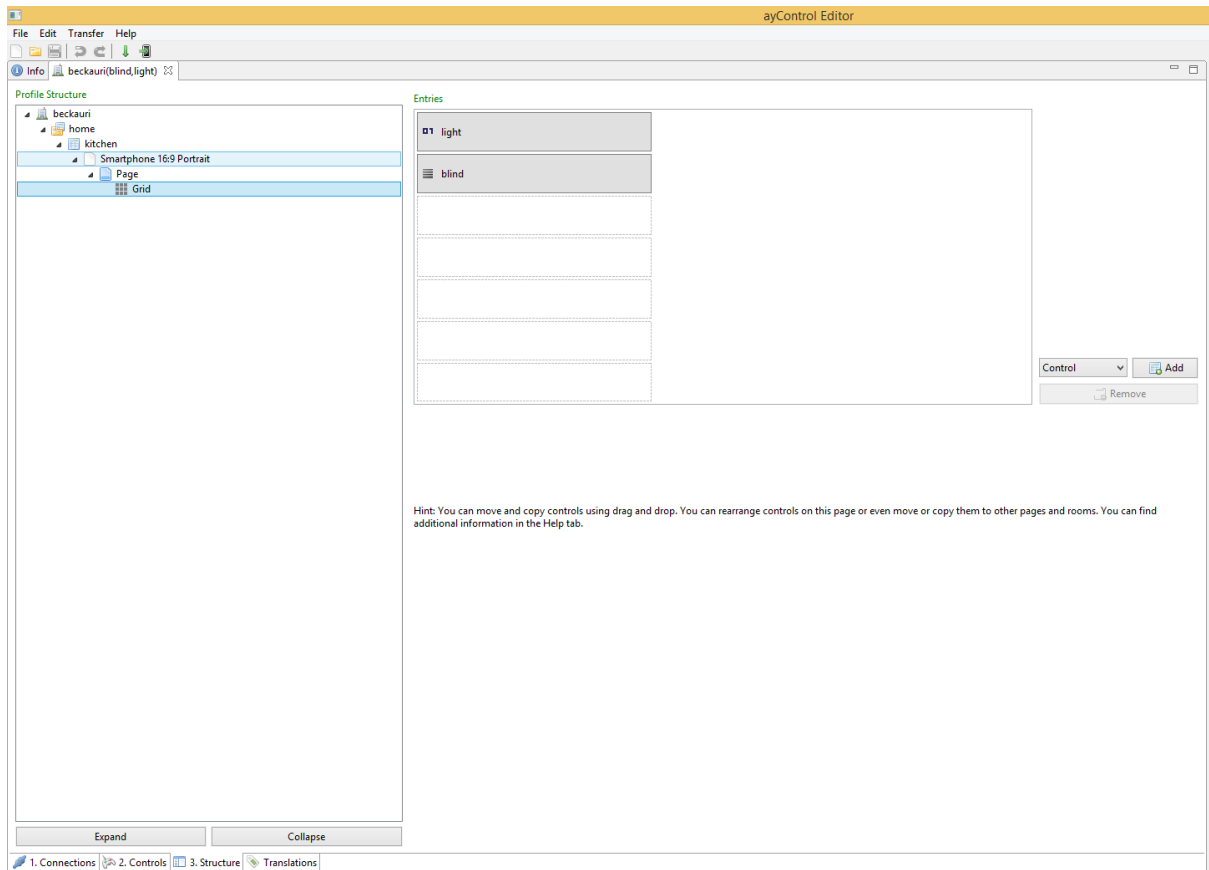

Figure 61. Blinds and lights control project in ayControl Editor.

7.3. spaceLYnk visualization

Get started with spaceLYnk.

1. Mount the device on DIN rail.
2. Connect the KNX bus cable
3. Connect 24V power supply to the device (Positive conductor to the red clamp, negative conductor to the blue clamp). Power supply REG/24V DC/0,4A, article No.: MTN693003.
4. Connect Ethernet cable from the PC.
5. Default IP address of the spaceLYnk device is 192.168.0.10. Change the IP address of the computer to the same range e.g. 192.168.0.9; mask 255.255.255.0.
6. Run Google Chrome or Mozilla Firefox and go to 192.168.0.10.

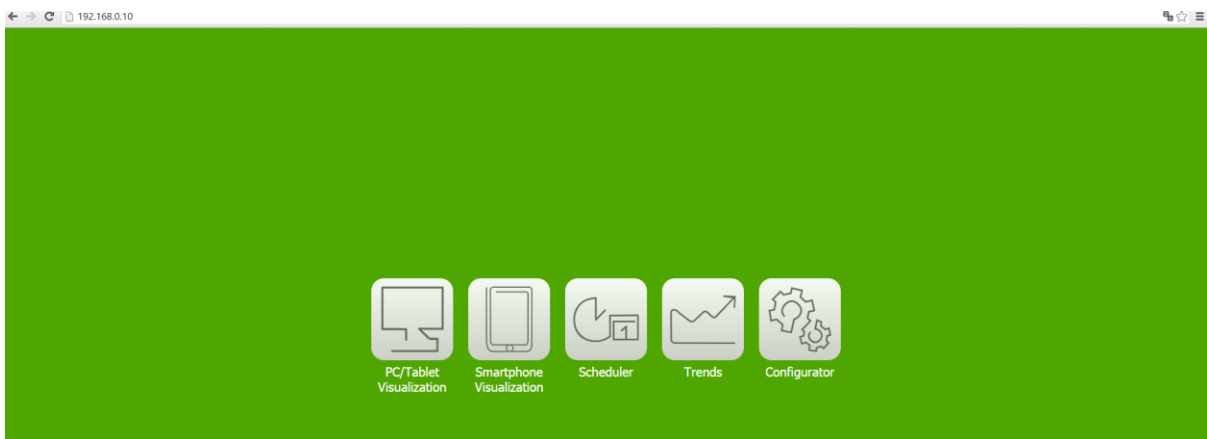

Figure 62. IP address in Google Chrome.

- PC/Tablet Visualization – This icon navigates to the rich visualization with maps containing individual objects. It is ideal for PCs, iPads and Android tablets.
- Smartphone Visualization – This icon navigates to the simple list visualization designed for iPhone/iPod/iPad/Android smart phones/ Android tablets
- Scheduler – This icon navigates to a user friendly interface for the end-user to manage scheduler tasks for example, to specify thermostat values depending on the day of the week, time and holidays.
- Trends – This icon navigates to a user friendly display of Trend logs with the ability to compare data between two different dates. It can display trends for up to 10 years.
- Configurator – This icon navigates to programming, settings and configuration interface. Access is restricted to administrators.

Objects

List of KNX network objects appear in the Objects menu. The object is listed accordingly:

1. Captured by sniffing the bus for telegrams from unknown group addresses (if enabled in Utilities).
2. Added manually.
3. Importing ESF file (in Utilities).

Group address	Object name	IP	TP	Event script	Data type	Current value	Log	Export	Tags	Updated at	Set value	Vis. paramet.	Custom values
1011	Used energy				13.4-byte signed integer	2078				07.04.2016 18:16:22			
1013	Power				09.2-byte floating point	0.249V				07.04.2016 18:16:12			
1014	Current				09.2-byte floating point	1064.96mA				07.04.2016 18:16:12			
1015	Alarm (500mA)				01.905 alarm	Over limit				07.04.2016 17:00:20			
1110	Current em3155				09.2-byte floating point	1.42A				07.04.2016 18:15:09			
1111	Used energy em3155				13.4-byte signed integer	26706				07.04.2016 18:15:09			
1112	Voltage-em3155				09.2-byte floating point	238.72V				07.04.2016 18:15:09			
1114	Frequency				14.4-byte floating point	49Hz				07.04.2016 18:15:09			
1209	Wind				09.2-byte floating point	0km/h				07.04.2016 17:09:35			
1211	Rain				01.905 alarm	No rain				07.04.2016 17:09:36			
1212	Temperature				09.2-byte floating point	25.9°C				07.04.2016 18:06:28			
1213	Brightness				09.2-byte floating point	15.58Lux				07.04.2016 17:31:05			
1440	Light on/off				01.901 switch	on				07.04.2016 17:09:33			
1500	Heating on-off				01.901 switch	off				07.04.2016 17:09:34			
2000					01.1-bit (boolean)	0				31.03.2016 15:48:52			
3000					01.1-bit (boolean)	0				31.03.2016 15:48:52			
3001					01.1-bit (boolean)	0				31.03.2016 15:48:52			
3002					01.1-bit (boolean)	0				31.03.2016 15:48:53			
3003					01.1-bit (boolean)	0				31.03.2016 15:48:53			
4110					01.1-bit (boolean)	1				07.04.2016 17:19:58			
4113					01.1-bit (boolean)	1				07.04.2016 17:16:10			
5014					01.1-bit (boolean)	0				01.01.2001 01:00:58			
15110					09.2-byte floating point	499.94				07.04.2016 18:16:15			
15111					05.19-byte unsigned integer	91				07.04.2016 18:16:16			
15112					09.2-byte floating point	24.72				07.04.2016 18:16:00			

Figure 63. Objects menu

Objects are further distinguished by color of their background for quick overview:

- Green – Object value actually updated.
- Yellow – Object actually discovered by a bus sniffer.

Schedulers

Schedulers allow the end user to control KNX group address values based on the date or day of the week.

Navigation icons: Home, Light, Schedulers, Graph, Calendar.

Figure 64. Schedulers.

Name	Object	Start date	End date	Events	Active	Duplicate	Status
kitchen Light	1440 (Light on/off)	14 April	16 November				

Figure 65. Schedulers menu.

Scheduler Events

Event can be added both in the administrator interface and by the end user in the special User mode schedulers interface.

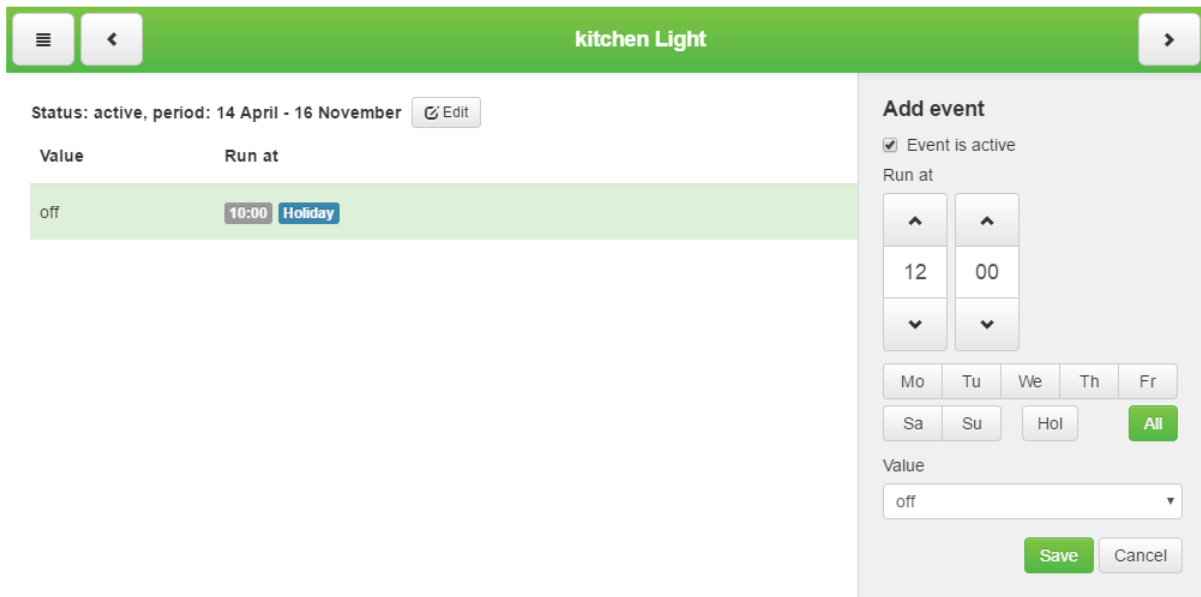

Figure 66. Adding new Schedulers Events.

Scheduler Holidays

Once the event will be marked to run on Hol, holiday entries will be activated.

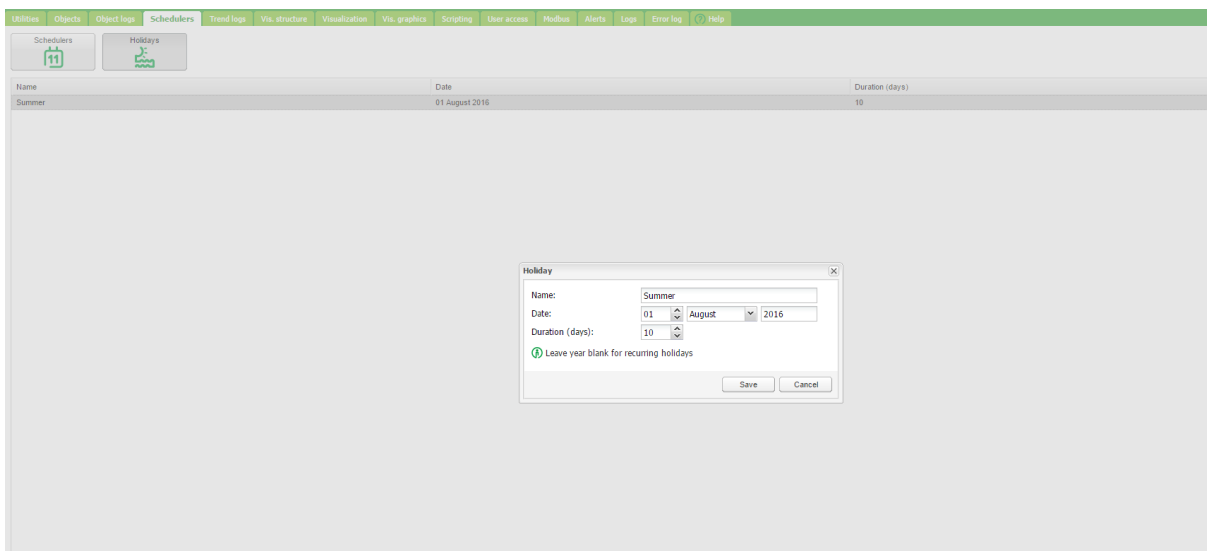

Figure 67. Adding new Scheduler holidays.

Trend logs

Add New Trend Log.

- Object – Choose from the list of objects the one to make the trends for.
- Name – Name of the trend.
- Log type – Type of the log.
 - Counter - Used to count the data.
 - Absolute value – Saves the actual readings.
- Hourly data – Time of storage of hourly data. (Max.5 years.)
- Daily data – Time of storage of daily data. (Max. 10 years).

- **NOTE:** Trend logs are stored in internal SD card memory.

Name	Object	Log type	Floating point precision	1 minute data	Hourly data	Daily data	Log size	Created	
Used energy kWh (MTN6600-0603)	1/0/1 (Used energy)	Counter	2	1 hour	180 days	180 days	37 KB	2016.03.21 20:05	🗑️
Used energy kWh (em3155)	1/1/1 (Used energy em3155)	Counter	2	1 hour	180 days	180 days	37 KB	2016.03.21 20:06	🗑️
Brightness	1/2/3 (Brightness)	Absolute value	2	1 hour	180 days	180 days	37 KB	2016.04.07 18:29	🗑️
Temperature	1/2/2 (Temperature)	Absolute value	2	1 hour	180 days	180 days	37 KB	2016.04.07 18:29	🗑️
Wind	1/2/0 (Wind)	Absolute value	2	1 hour	180 days	180 days	37 KB	2016.04.07 18:30	🗑️

Figure 68. Trend logs.

Trend logs or so called data logging allows the end user to store the selected data and compare the different time periods from the past.

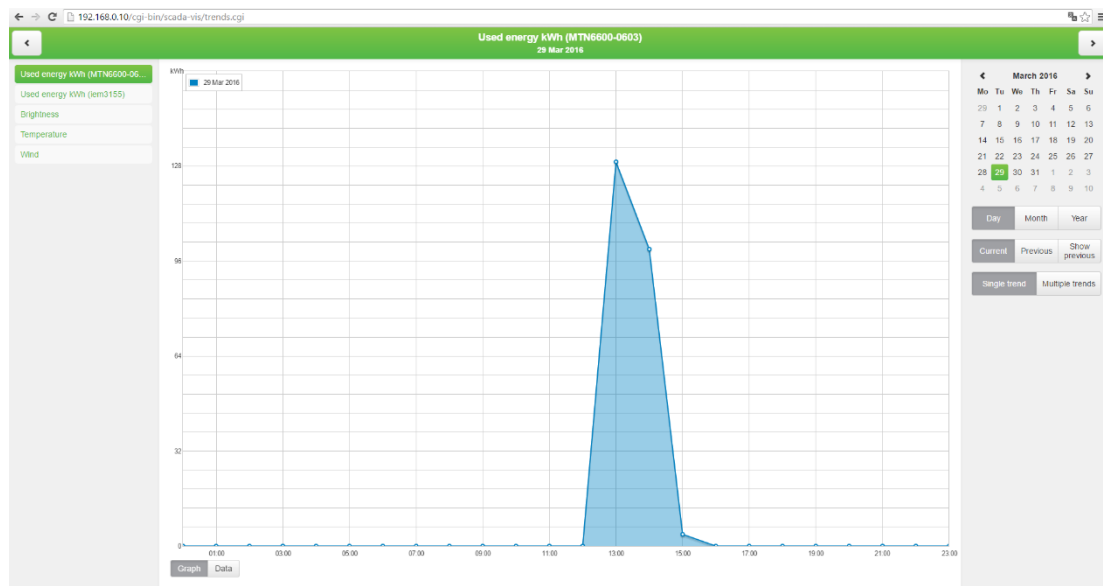

Figure 69. Trend logs database.

Visualization Structure.

Plan.

Plan can show either one room in a flat with cumulated functions or one function (as lighting or heating) of the whole flat.

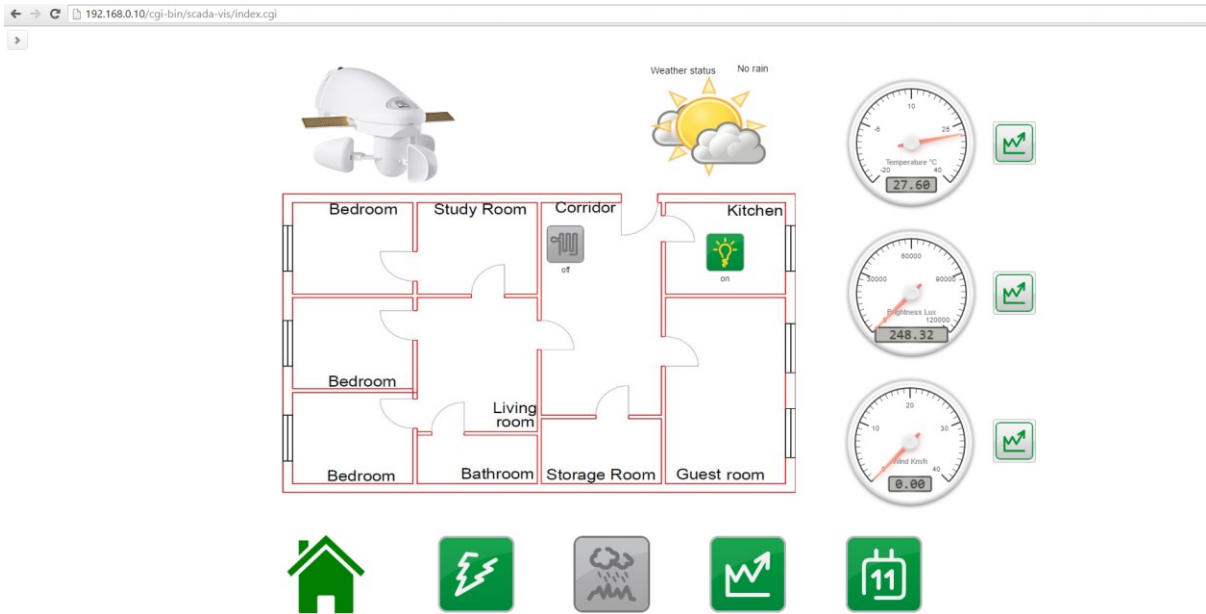

Figure 70. Visualization home plan.

Switching of lights in Rooms (Kitchen) are depended on Brightness of sun during the day. In ETS4 user can make parameters to be switched on or switched off lights according the luminosity. It saves energy consumption during sunny days. As the luminosity goes down (300Lux) Light in kitchen is switched on. There is the same structure about heating in Corridor when the temperature drops below 22°C the heating is switched on automatically.

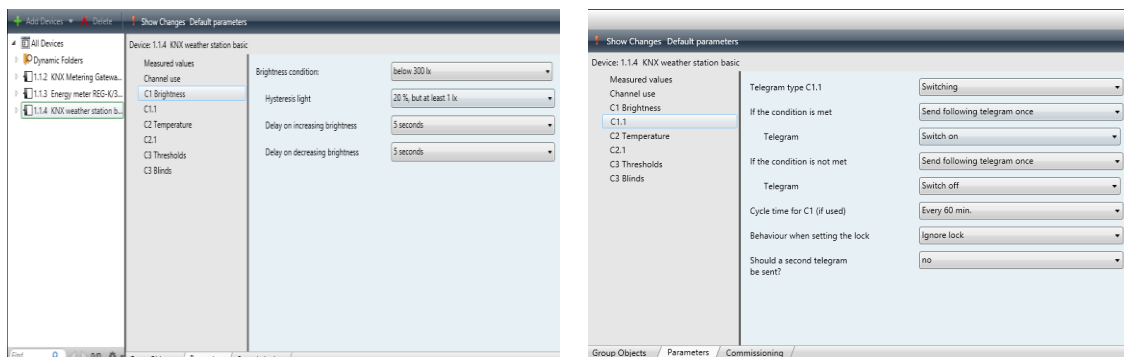

Figure 71. Light. Control according Lux. in ETS4.

Visualization.

This tab is split into three sections:

- Structure – Navigation tree for levels, plans, widgets which were created under the visualization structure tab.
- Visualization map – Actual visualization field where you can add all visualization components.
- Plan Editor – All parameters of the component are set up here.

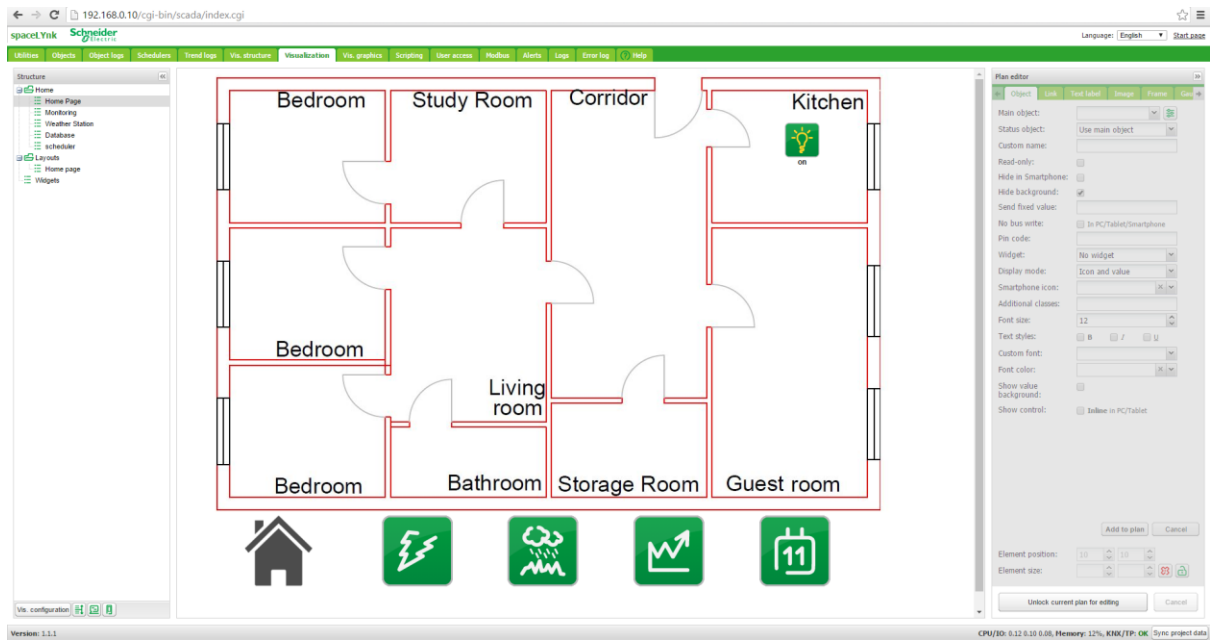

Figure 72. Visualisation.

Plan editor is located on the right side of the visualization map. Editing mode can be accessed by pressing Unlock current plan for editing.

- Object
 - Every control or monitoring objects are configured under this tab. Different data types have different parameters.
- Link
 - In order to make the visualization more convenient, there are plan links integrated. Special icons on the map can be added which would act as a link to other plans.
- Camera
 - spaceLYnk supports third party IP web camera integration into its visualization.
- Graph
 - Real-time graphs can be integrated into visualization system to monitor the current and the old value of the scale-type objects.
- Text label
 - Text labels can be added and moved across the visualization map.
- Gauge
 - Gauge allows dynamic way of visualization and changing the object value in the gauge.
- Image
 - Image section allows adding images from Local storage or from the internet into the visualization map.
- Frame
 - Frame allows displaying internal or external webpage in visualization. Schedulers and Trends can be integrated into the frame.

Layout

Layout is advanced background for plans. Any object from the editor can be placed on the layout which later can be attached to one or many plans. All objects from the layout will be visible on the plan, but all the objects on the plan will be above the objects from the layout.

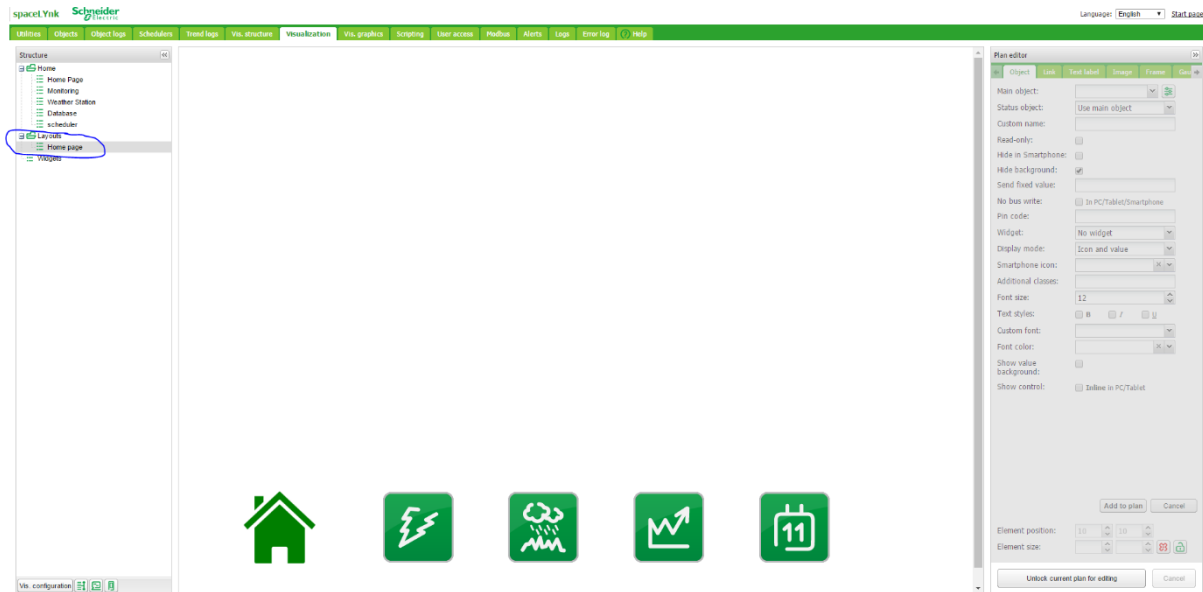

Figure 73. Layout.

Energy monitoring.

Energy monitoring page where are displayed all information about consumed energy measured by 2 different energy meters.

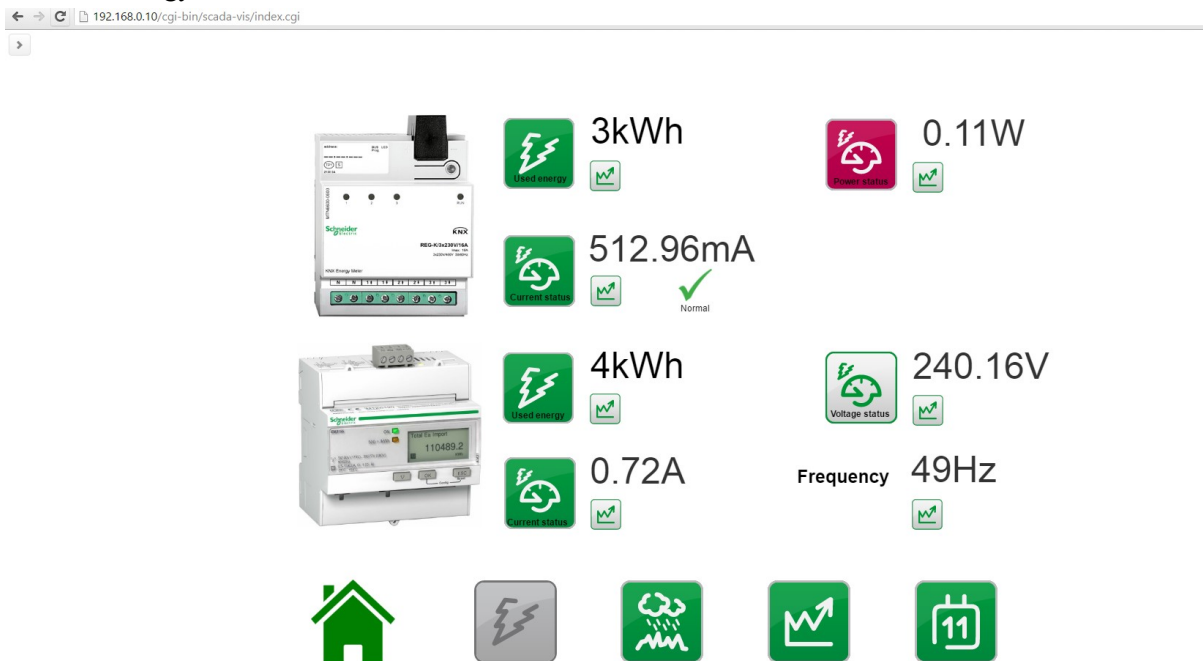

Figure 74. Energy monitoring (SCADA)

Alarm indicator.

User can control energy consumption by setting limit on current usage. In ETS4 can be modified parameters of Energy meter on current usage as it can be set that as soon as it exceeds indicated value of current, alarm will be displayed near current status and notifies user to reduce energy consumption.



Figure 75. Alarm indicators.

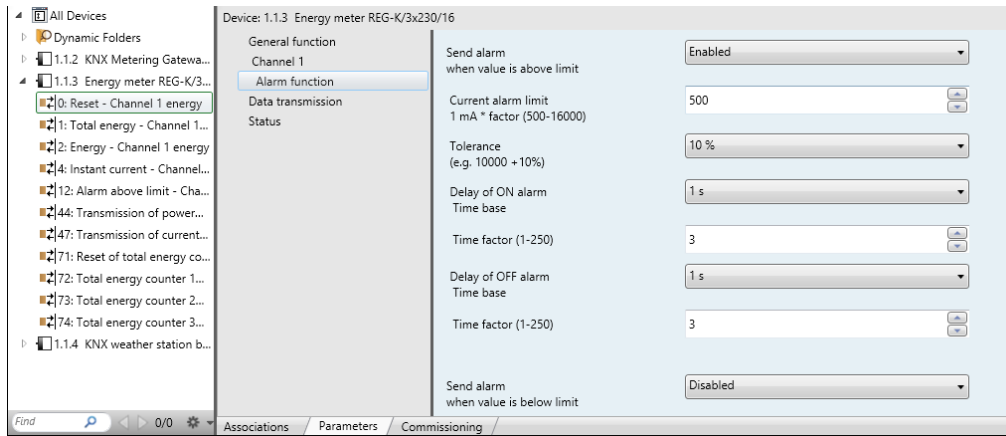

Figure 76. Current usage alarm in ETS4.



Real-time graphs

They are integrated into visualization system to monitor the current and the old values of the scale-type objects. (Figure 77)

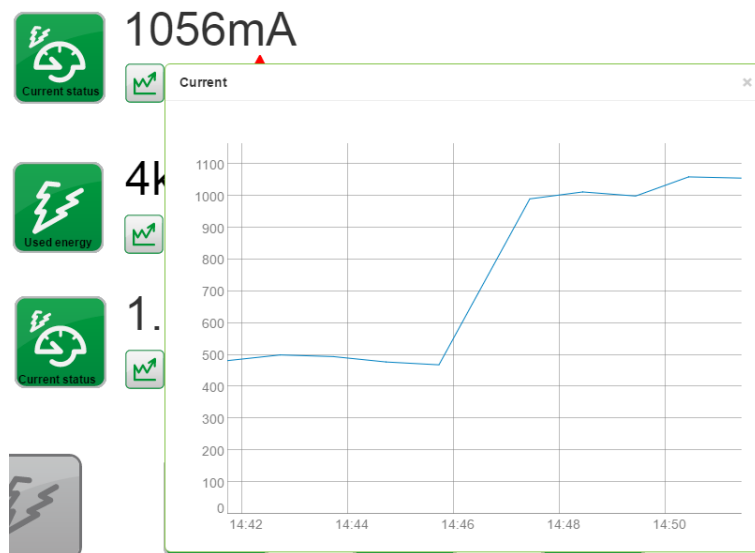

Figure 77. Current real-time graph.

7.4. Visualization

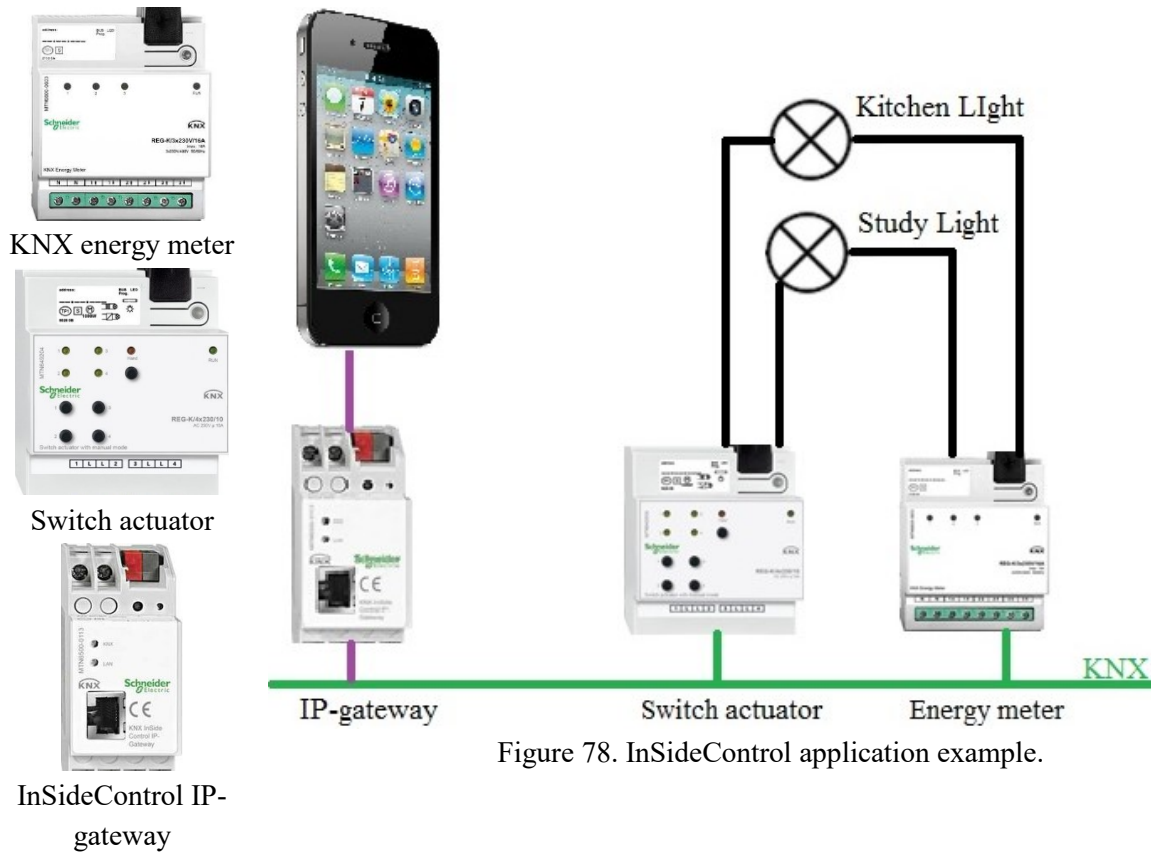

Figure 78. InSideControl application example.

Solution:

By connecting KNX Energy Meter and Switch Actuator, it is possible to make record the consumption of individual loads, load groups and whole rooms. Also, it is possible to programme individual energy-saving functions such as switching, dimming and scene retrieval. If certain threshold values are over limit, this means alarms can be triggered and displayed on the mobile, or loads and load groups can be switched off automatically.

Advantages:

KNX Energy Meter measures the individual consumption of your three channels as well as measuring the total consumption and providing this information via the bus. The internal clock attaches a time stamp to all measured data, which allows precise time allocation. By combining KNX Energy Meters and Switch Actuators, it is thus possible to design an individually adapted energy-saving system which actively accesses all the components of the KNX installation, and permits not only differentiated energy measurements but also active energy-saving modes. [32]

8. Smart Home scenario for energy saving.

8.1. Scenario

In Smart home scenario is pre-programmed algorithm of the system behaviour in accordance with a particular event. Such events can be very different:

1. Pressing the button (long or short)
2. The signal received from the sensor (level of the brightness, temperature, movement)
3. The team with the remote control or a computer
4. Operation of scheduled or timer.
5. Spoken keyword

Scripting - a simple thing, it is a way of life defined by the owners and their imagination. For example, one of the scenarios include the following options:

1. There is no one In the house (all lights are turned off, water is blocked, climate control functions are in economy mode)
2. Adult comes home (turn on lights in the hallway, in the kitchen - coffee maker, air conditioning and stereo in the living room, etc.);
3. The child comes home (locked hook up a home theatre, food maker in process, electronics are disabled, can be reproduced with video message from parents, etc.).
4. Disable all - feature lets you turn off all the lights in one step, equipment, heating devices, which can be forgotten when leaving the house.
5. Holiday mode (long absence). Most systems are completely disconnected and only the video surveillance system protection and maintenance work of security systems.
6. Someone came to the house. The hall lights light displays the system messages, the program indicates the number of missed calls on the phone etc.
7. In the house there are guests. Disables saving in guest rooms, air conditioning, heating and heating work at the desired power.

It is also possible to create algorithms depending on time of day:

- Morning - the light in the soft mode, the warm climate of the air conditioning, floor heating, music schedule, switch the TV at a specified time.
- Day - light sensor is configured to maintain the necessary level of lighting in the room; luminance varies depending on the light coming from the windows, air conditioners function actively.
- Evening - muted light in the corridor, air conditioners go into a special mode, you can include special lighting scene.

Examples of scenes and central functions:

- scenes: guests, cleaning, coffee break, film, reading, dinner party, cooking, dinner, date, sleep (turns off all lamps, rolls down the blinds, arms the alarm system), wake-up, alarm (turns on all outside lamps to scare the intruder away)
-
- when exiting the room - turns off all lights
- when exiting the house - turns of all lights, rolls down the blinds, decreases the heating
- raising/lowering of all window blinds

9. Conclusion

This master's thesis aims energy management in Smart homes by monitoring and controlling energy and electricity consumption. In this work are described several steps of energy management.

At the begging of this work I performed research of theoretical part of current state issue of building control and smart homes. Explanation of abbreviations of smart home, providers, users, building control and SCADA. I tried to explore different ways of energy management in smart homes and description of structure of building control and automation.

I analysed information about energy consumption trends in Czech Republic over years by different consumers. I found out that residential part has been doubled over 40 years that was motivation to create system of devices for efficient energy usage.

In the following part of thesis are discussed current technologies which are used in smart homes and best solution for energy management. For energy use visualization I have used KNX technology, since according to my research for building room level control KNX protocol is most flexible. In the other hand, KNX is international open protocol and it can be integrated to other different protocols: BACnet LON and Modbus that made me sure choosing KNX protocol for energy management.

Moreover, I tried to perform detailed description of KNX standards and devices. Also I have mentioned information about ETS software which is used for programing parameters of KNX devices.

Under the paragraph room automation in this part I have explained KNX solutions for lighting, blinds and comfort control. I have drawn wiring and details of each devices that is needed for particular control.

In addition, I have created project of Mobile laboratory and schemes of wiring KNX devices for energy and electricity measurement and visualisation, I have used weather station to get information about luminosity and temperature to reduce usage of lights and heating in rooms.

In the last part of thesis is described results of measured data and visualization. Mobile and PC control has been used for monitoring energy consumption. For mobile control I used two different applications ayControl and InSideControl to get information about measured data from KNX bus in mobile that is connected to KNX router. For PC visualization has been used KNX device spaceLYnk, it guaranties data transmission between PC and KNX bus, it's connected via IP network and after running IP address in Google Chrome user receives real-time information about energy consumption and database of measured energy over years, as this device is supported own memory card where all information is saved and secured for database and trend logs. Beside of the database it supports event schedulers to set up timers for individual loads when to be switched on and switched off.

In addition, the most important issue is the level of energy efficiency that can executed by visualisation energy usage in mobile device and PC to be visible for end-user for motivating to make savings and set alarms of over limit energy consumption.

The result of this thesis is that I have created system of devices using KNX protocol for visualization of consumed energy and electricity also lights, blinds, heating control via mobile devices and PC. In addition, plugged in database for saving consumed energy data over years, so user is able to have access to monitor history of energy usage.

10. References

- [1] A. Zipperer, P. Aloise-Young, S. Suryanarayanan and D. Zimmerle, "Electric Energy Management in the Smart Home: Perspectives on Enabling Technologies and Consumer Behavior," 2013.
- [2] C. C. Teoh, "A Neural Network Approach towards Reinforcing Smart Home Security," Malaysia.
- [3] C. Yang and B. Yuan, "A Smart Home Architecture Based on Resource Name Service," China, 2014.
- [4] D. M. L. a. W. T. Claridge, Commissioning of existing buildings - state of the technology and its implementation. Proceedings of the International Short Symposium on HVAC Commissioning., Kyoto, Japan, 2003.
- [5] Y. Lim, "<http://www.jaist.ac.jp>," [Online].
- [6] Y.-S. S. a. K.-D. Moon, "Home Energy Management System Based on Power Line Communication," IT Convergence Technology Research Laboratory, Daejeon, Korea.
- [7] T. H. C. H. Hermann Merz, Building Automation: Communication systems with EIB/KNX, LON and BACnet, Germany: Springer.com, 2009.
- [8] ASHARE, "ANSI/ASHARE Standard 135-1995. BACnet.-A Data Communication Protocol for Building Automation and Control Network," Atlanta, Georgia, JSA,, 1995,.
- [9] Z. Wang and X. Liu, "BACnet Intelligent Home Supervisory Control System Based On Multi-Agent," Optoelectronics Engineering Department, Huazhong univ. of Sci. & Tech, China.
- [10] T. S. P. F. M. S. H. M. Z. V. Fernandes, "Intelligent SCADA for Load Control, IEEE International Conference on Systems, Man and Cybernetics," Istanbul, Turkey, Oct. 12-15, 2010.
- [11] H. M. P. F. Z. V. C. R. Filipe Fernandes, "SCADA House Intelligent Management for Energy Efficiency Analysis in Domestic Consumers," GECAD - Knowledge Engineering and Decision Support Research Center, Porto, Portugal.
- [12] D.-M. Han and J.-H. Lim, Smart Home Energy Management System Using IEEE 802 and Zigbee, South Korea, 2010.
- [13] KNX, "Smart Meteringwith KNX".
- [14] schneider-electric, "Acti 9 iEM3000 series," [Online]. Available: <http://www.schneider-electric.com/en/product-range/61273-acti-9-iem3000-series/>.
- [15] C. W. Factbook, "www.indexmundi.com," 2014. [Online]. Available: <http://www.indexmundi.com/g/g.aspx?v=81&c=e&l=en>.
- [16] OECD/IEA, "ELECTRICITY INFORMATION," International Energy Agency, France, Paris, 2012.
- [17] P. R. Q. Liu, "Study on the Congestion Control Arithmetic of BACnet Routers," Wuhan University of Technology, China.

- [18] *Building automation and control systems -- Part 5: Data communication protocol*, 2003.
- [19] R. a. A.-C. E. American Society of Heating, "Specifying Direct Digital Control Systems," Atlanta, 2000.
- [20] Wikipedia_BACnet, "<https://www.wikipedia.org/>," Wikipedia, [Online]. Available: <https://en.wikipedia.org/wiki/BACnet>.
- [21] ABB, "Technology of Choice Smart Home and Intelligent Building Control," ABB i-bus® KNX, Germany, 2010.
- [22] KNX-Association, "Serial Data Transmission and KNX Protocol".
- [23] MatrikonOPC, "www.matrikonopc.com," KNX OPC Server, [Online]. Available: <https://www.matrikonopc.com/opc-drivers/opc-knx/base-driver-details.aspx>.
- [24] K. A. "Home and Building Management Systems, KNX Project Design ETS4".
- [25] KNX, "www.knx.org," KNX, [Online]. Available: <https://www.knx.org/in/software/ets/about/index.php?navid=948232948232>.
- [26] KNX, "ETS5 for Beginners," www.knx.org.
- [27] climatemaster, "<http://ww1.climatemaster.com/commercial/>," [Online].
- [28] Schneider Electric, "Application DALI Control IP1 7307/1.0a," 2013 .
- [29] "homnical," [Online]. Available: <https://www.omnical.nl/>.
- [30] Schneider_electric, "Plan for intelligent," Schneider Electric Industries SAS, Cologne, Germany, 2013.
- [31] schneider-electric, "InSideControl BuilderSystem Overview," 03.2013.
- [32] S. E. I. SAS, "Building Control Systems," Schneider Electric Industries SAS, France, 2013.
- [33] J. Vanus, P. Vojcinak, R. Martinek, M. Kelnar, M. Zdenek, P. Bilik and J. Koziorek, "Building Heating Technology in Smart Home Using PI System Management Tools," <http://www.sciencedirect.com/>, Ostrava, Czech Republic, 2015.
- [34] "<http://www.bacnet.org/>," ASHRAE SSPC 135, [Online]. Available: <http://www.bacnet.org/Tutorial/BACnetIP/sld003.html>.
- [35] Schneider-Electric, "KNX Building Control System," [Online]. Available: <http://www2.schneider-electric.com/sites/corporate/en/products-services/product-launch/knx/how-does-knx-works.page>.
- [36] schneider-electric, "Plan for intelligent future safety," chneider Electric Industries SAS, France, 2013.