

Wearable Architecture: Fashion to the Rescue

Cherri Mariñas
May 2011

Submitted towards the fulfillment of the requirements for the Doctor of Architecture degree

School of Architecture
University of Hawai'i

Doctorate Project Committee

Chairperson: Amy Christie Anderson
Geoffrey Lewis
Darius Homyay

Wearable Architecture: Fashion to the Rescue

Cherri Mariñas

May 2011

We certify that we have read this Doctorate Project and that, in our opinion, it is satisfactory in scope and quality in partial fulfillment for the degree of Doctor of Architecture in the School of Architecture, University of Hawai'i at Mānoa.

Chairperson: Amy Christie Anderson

Geoffrey Lewis

Darius Homay

Abstract

This dissertation, titled “Wearable Architecture: Fashion to the Rescue,” studies fashion and architecture in order to assess if the emerging urban nomad fashion trend can inform a new direction in temporary disaster relief for the families of Hawai‘i. The intention is to discover whether the clothes and accessories worn by survivors of natural disasters in bicoastal cities can provide shelter and relief to survivors between the event and the supply of government issued temporary housing.

The methodologies used to prove the need for a wearable disaster relief kit are organized into three parts. The first topic researched is natural disasters. Analysis and observation of natural disasters support and demonstrate the need for a kit in times of a natural disaster. This section covers the various needs and problems of a disaster victim and thus reveals what design features should be incorporated into the proposed prototype. The second topic researched is minimalist shelters, which include indigenous shelters, low-income housing, and homeless shelters. This study is crucial as it explores the world of people who live with only the most basic and simple items that are necessary for survival. The resulting information is aimed at defining the basic essentials of everyday survival and how these necessities can be incorporated into a wearable disaster relief kit. The third topic researched is current related technologies. While the first two parts focus on the needs of people following a natural disaster as well as on a day-to-day basis, this part focuses on the tools and inventions that people have created to help address those needs. The information gathered concentrates on portable architecture, wearable architecture, survival kit tools, and materials. With this information, ideas for the prototype arise as the potential and constraints of each invention are examined, thus paving the way for design features that can be incorporated into the proposed prototype.

Based on the information gathered, the design parameters were created and this list served as a guide for the wearable disaster relief kit prototype. By establishing the limitations and structure of the design, it paved the way for the design of The Compleat Retreat. The Compleat Retreat is an all-in-one shelter, jacket, floatation device and emergency kit.

Table of Contents

Introduction	1
0.1 Background/Field of Study	1
0.2 Project Statement	3
Part 1: Research Summary	
Chapter 1 Case Studies on Natural Disasters	4
1.1 Hurricane Iniki	5
1.2 Hurricane Katrina	10
1.3 American Samoa Earthquake and Tsunami.....	14
1.4 Conclusion	17
Chapter 2 Minimalist Structures	24
2.1 Indigenous Shelters.....	25
2.11 Ephemeral or Transient Dwellings	29
2.12 Episodic or Irregular Temporary Dwellings	31
2.13 Periodic or Regular Temporary Dwellings	34
2.14 Seasonal Dwellings.....	38
2.15 Semi-permanent Dwellings.....	40
2.16 Indigenous Shelters Conclusion	42
2.2 Low-income Housing.....	46
2.3 Homeless Dwellers	47
2.31 Homeless Shelters	48
2.32 Tent Dwellers.....	53
2.33 Street Dwellers.....	55
2.34 Cart Dwellers.....	57
2.35 Homeless Dwellers Conclusion	58
2.4 Minimal Structures Conclusion.....	63
Chapter 3 Current Technologies	64
3.1 Wearable Architecture	66
3.11 Prefab Coat.....	68
3.12 Final Home Jacket	70
3.13 Vessel.....	72

3.14 Connector Mobile Village	74
3.15 Wearable Architecture Conclusion	77
3.2 Product Design	80
3.21 Patagonia	81
3.22 The North Face	83
3.23 Product Design Conclusion	87
3.3 Survival Tools	88
3.31 Inflate-a-Potty	89
3.32 All Weather Hooded Thermal Survival Blanket	89
3.33 Light Stick Green 12-Hour	90
3.34 Radio Flashlight Cell Phone Charger	90
3.35 Lifestraw	91
3.36 Survival Tools Conclusion	92
3.4 Current Technologies Conclusion	92
Chapter 4 Research Summary	93
Part 2: Design	
Chapter 5 Design Parameters	100
5.1 Primary Components	100
5.2 Secondary Components	101
5.3 Survival Gear	102
5.4 Summary	102
Chapter 6 Design Process	104
6.1 Design Study	104
6.11 Study 1: Figure 34	104
6.12 Study 2: Figure 35	106
6.13 Study 3: Figure 36	106
6.14 Study 4: Figure 37	108
6.15 Study 5: Figure 38	111
6.16 Study 6: Figure 39	112
6.2 Final Design	113
Chapter 7 Conclusion	134

7.1 General Conclusion	134
7.2 Strengths and Limitation of the Design	136
7.3 Further Research	138
7.31 Floor Mat	138
7.32 Expansion	139
7.33 Thin Cell Solar Membrane	139
7.34 Secondary Structure	140
7.35 Hardware	140
7.36 Shrug Lining.....	141
7.37 Backpack.....	141
7.38 Color	141
7.39 Size	140
7.4 Parallels of Architecture and Fashion	142
7.5 Personal Statement	144
Bibliography	145
Photo Credits.....	148

Acknowledgements

My years at the University of Hawai'i School of Architecture has had mentorship from numerous individuals both from within and outside of the university. It is to these individuals that my heartfelt gratitude goes out to, because without their love and support, none of this would be possible.

I would like to thank my committee members for all of their support in helping me figure out how to merge the disciplines of fashion and architecture. Amy Anderson, you have been a great chairperson who has been actively involved in my pursuit to design a wearable tent. Thank you for listening to all of my ideas and pushing me forward whenever an obstacle came my way. Geoffrey Lewis, your architectural feedback, design aesthetic, and camping experiences has played an influential part in my project. Thank you for always fitting me into your busy schedule and helping me make important design decisions. Darius Hoday, your wealth of knowledge on fabrics and fashion has given me significant guidance that enabled me to reach my project goals. Thank you for helping me with all of my fashion explorations and especially for sharing your kimono knowledge with me. To my committee, your time and kind words will always be valued.

I would like to thank those closest to me, whose presence helped make the completion of my graduate work possible. My parents, your unconditional love and support has gotten me to where I am today. Thank you for your continued emphasis that I can achieve anything that my heart desires. My sisters, Crystal and Starlette, your guidance and intelligence has given me a strong foundation on which to build my educational and life journey. Thank you for always being there for me, keeping me in check, and most of all, for listening to my random antics. My best friend, Keala, your continued love and support has helped me get through this program, especially in times when I felt far away from my home and family. Thank you for believing in me even when I didn't believe in myself. My architecture friends, you guys and gals always knew the right kind of advice to give during stressful times. Thank you for the memories and friendships that will last forever. To my family and friends, your strength and wisdom will always be appreciated and I'll always love you for that!

Introduction

0.1 Background/Field of Study

The studies of architecture and fashion have always been an intriguing and passionate interest of mine. Architecture is a fascinating subject that was introduced to me at an early age, when my father brought home the floor plans for our new home. Since then, I've always been interested in architecture due to its creative qualities and ability to bring drawings into life. Fashion on the other hand, has naturally been an interest of mine as it deals with the glamorous and dolled up lifestyle that every girl dreams about starting at a young age. Between the two topics of architecture and fashion, both are equally appealing to me and as a result, it comes with no surprise that the study on the parallels of fashion and architecture would draw my attention.

Architecture as fashion and fashion as architecture are increasingly common topics of discussion. The parallels between the two are many; for instance, both provide shelter, can be mobile, and have an effect on urban space. Looking at shelter, the clothes we wear shelter our bodies and the buildings we design provide shelter to the community. Both clothes and buildings can be mobile while still providing shelter. Focusing in on fashion's effect on urban space, it can create urban nomads who at times use their transformable clothing to occupy outdoor sites. Buildings on the other hand create urban spaces for the community. These connections and parallels between architecture and fashion inspired me to develop and design wearable architecture for disaster relief.

Wearable architecture is clothing that can stretch beyond its conventional use and thus transform into a, more or less, structural and temporal shelter. I believe that in the event of a natural disaster, wearable architecture can inform a new direction in disaster relief and provide assistance to people. Such articles of clothing will be

designed as mobile buildings that are self-sufficient, inhabitable by a single individual, and capable of being used to create larger environments. Robert Kronenburg argues that transportable and temporary structures are an ineffective solution to disaster relief. He supposes that:

transportable structures are often associated with shelter after disaster situations; however, their deployment may not always offer the most effective solution. The design of many temporary structures of this kind has been donor-led rather than user-led and their provision has too often been inappropriate and too late. In many disaster response situations there are much higher priorities for the victims and resources could be better spent in other ways. The longer-term issue is to provide help with the rebuilding of the disaster hit area, enabling residents to stay close to their home and possessions and begin rebuilding their lives, dwellings and occupations. (Kronenburg 1998, 4)

Kronenburg makes a number of valid points; however, I believe that although wearable architecture is a transportable and temporary solution, it will be effective because it will be user-led. Due to its wearable qualities, it will be of aid prior to, during, and after a natural disaster, relieving immediate shelter and supply concerns. While Kronenburg argues that these structures are not the best solution to facilitating a person's road to recovery, I feel that wearable architecture is a necessary, compassionate, and thoughtful response to a difficult and complex dilemma.

Wearable architecture has great potential for providing disaster relief. One advantage is its ability to provide the benefits of a permanent building and, eventually, a sense of home. These fully equipped pieces of clothing have the talent to "transform into a protective shell [that is] equipped with extra warmth and enough supplies to enable us to spend a night away from home" (Quinn 2003, 102). Another benefit is the potential to address and support the need to be mobile while keeping one's hands free. This hands free feature is very helpful as it allows people to function normally as well as to be of aid to others. For instance, it allows a parent to hold the hand of his or her child or to carry a bag filled with emergency supplies or everyday essentials. A third benefit is the idea of having one less thing to worry about, which helps to keep a person's stress level at a minimum. A fully equipped article of clothing that can be converted into a shelter alleviates the number of concerns a person has after a natural disaster. It gives one hope that chances of survival are not slim and helps time to pass more smoothly.

0.2 Project Statement

This dissertation, titled “Wearable Architecture: Fashion to the Rescue,” studies fashion and architecture in order to assess if the emerging urban nomad fashion trend can inform a new direction in temporary disaster relief for the families of Hawai‘i. The intention is to discover whether the clothes and accessories worn by survivors of natural disasters in bicoastal cities can provide shelter and relief to survivors between the event and the supply of government issued temporary housing.

This dissertation is intended to help solve the shortcomings of architecture in the aftermath of a destructive force. History has proven that survivors of natural disasters are left with feelings of concern and distress and have little knowledge of how to lessen an emergency’s impact. The goal of this study is to design a prototype for the people of Hawai‘i that will help to alleviate some of the concerns associated with a catastrophic event. The prototype will be designed for an individual; however, it will have the ability to connect to another shelter in order to create a larger space and accommodate a family.

The methodologies used to prove the need for a wearable disaster relief kit are organized into three parts. The first topic researched is natural disasters. Analysis and observation of natural disasters support and demonstrate the need for a kit in times of a natural disaster. This section covers the various needs and problems of a disaster victim and thus reveals what design features should be incorporated into the proposed prototype. The second topic researched is minimalist shelters, which include indigenous shelters, low-income housing, and homeless shelters. This study is crucial as it explores the world of people who live with only the most basic and simple items that are necessary for survival. The resulting information will be aimed at defining the basic essentials of everyday survival and how these necessities can be incorporated into a wearable disaster relief kit. The third topic researched is current related technologies. While the first two parts focus on the needs of people following a natural disaster as well as on a day-to-day basis, this part focuses on the tools and inventions that people have created to help address those needs. The information gathered concentrates on portable architecture, wearable architecture, survival kit tools, and materials. With this information, ideas for the prototype arise as the potential and constraints of each invention are examined, thus paving the way for design features that can be incorporated into the proposed prototype.

Chapter 1

Case Studies on Natural Disasters

Disasters, whether predictable or unpredictable, come in all forms including fire, land movement, water, and weather events. Regardless of the type of disaster, they do not discriminate and cause human loss and property damage in all affected areas.

In most cases, natural disasters are unstoppable and unpreventable. While some are predictable, others come as a surprise, making preparation almost impossible. With preparation and awareness, damage to individuals and material goods can be minimized. In addition, communities can prepare their households for the disaster and its aftermath. However, the strength of a disaster often exceeds the level of preparation, and individuals are left homeless. In these moments, the limitations of architecture become apparent as buildings are not portable and are forced to either withstand the power of nature or be destroyed.

This study reviews the effects of natural disasters on communities. The main purpose of this is to determine the necessities of disaster survivors and to express the urgent need for some type of user-led device, tool, or flexible garment that can immediately aid victims in times of a natural disaster. In order to keep the information relevant to Hawai'i, the research will focus on natural disasters that have affected coastal areas, including Kaua'i's Hurricane Iniki (1992), New Orleans' Hurricane Katrina (2005), and the American Samoa earthquake and tsunami (2009). Hurricane Iniki is especially significant to the study as it occurred and affected the people of Hawai'i, which is essentially the audience for the prototype. Hurricane Katrina is another appropriate disaster to analyze as it was arguably the worst natural disaster to strike the United States. As the American Samoa earthquake and tsunami of 2009 was one of the more recent disasters, the research on it will focus on how disaster relief is currently being addressed. Using these case studies, this study will analyze the human

responses and difficulties throughout all phases of each disaster. This information will reveal the various needs and problems of a disaster victim and thus aid in designing a wearable disaster relief kit prototype for the people of Hawai'i.

1.1 Hurricane Iniki



Figure 1. Aerial view of Waimea, Kaua'i showing the island-wide devastation and destruction caused by Hurricane Iniki.

On the afternoon of September 11, 1992, Hurricane Iniki – “the most costly natural disaster ever recorded in Hawai'i and one of the more costly hurricanes in U.S. history” (Chiu, et al. 1995, foreword) – brought piercing winds, high waves, and storm surge to the south shore of the island of Kaua'i. According to the Saffir-Simpson Hurricane Classification Scale, Hurricane Iniki was a Category 4 hurricane with damages estimated at \$1.8 billion dollars. Despite the extensive damage, the death toll was amazingly low with a total of six deaths. While the lives of many were spared, this was not the case for the homes of the survivors. According to the Red Cross, 14,350 homes on Kaua'i were affected, with 1,421 destroyed and 5,152 suffering major damage. With sustained winds blowing at 97 mph and 142 mph at its peak (Chiu, et al. 1995, 5-86), wind damage was generally the major cause of home damage.

Hurricane Iniki's destructiveness was immense, and consequently, many problems followed immediately after. However, there were several issues prior to the disaster as well. The first was awareness, which was complicated by the media's

unclear warnings regarding the hurricane's arrival. The next issue was finding adequate refuge and making sure that people brought all of the necessary supplies for survival, which are not provided by shelters. Following these pre-disaster issues, were many post-disaster issues, including homelessness, disrupted electrical power, lack of water, lack of information, torn up roads, and looting. All of these problems were felt by the residents and tourists of Hawai'i, and there are many lessons to be learned from how people survived and responded to the different challenges posed by the disaster. These issues reveal the needs of disaster victims, and for this reason more in-depth descriptions of each of the problems following Hurricane Iniki have been provided. Following each description are suggested attributes that should be incorporated into the proposed prototype.

Starting with awareness and preparedness for Iniki, some people found the notice short, with only sixteen hours between the warning and the storm's first impact (Chiu, et al. 1995, 86). In addition, the previous warnings by the media were unclear. On September 9, 1992, possible thunderstorms near Kaua'i were predicted, however, they were reported to be unlikely to affect island weather. On September 10, 1992, warm "hurricane weather" was felt throughout Hawai'i, and while meteorologists stated that the Hawaiian Islands would not be affected if Iniki stayed on course, forecaster Tim Craig cautioned, "the storm has a mind of its own and may hang right' (turn north). The operative word is 'may'." It was not until the day of the storm, September 11, 1992, that forecasters were positive that Hurricane Iniki would strike, which led to clear final warnings. As cautioned by Craig, the storm had turned right on its path and was moving towards the island of Kaua'i. At this point, all residents were advised to take immediate action: to assemble emergency survival supplies and gear, cover windows, secure loose objects, and be prepared to evacuate (Borg, et al. 1992, 19). This data suggests that any wearable emergency survival prototype should be accessible and easily donned to allow users to respond quickly to last minute warnings.

After word spread that the hurricane was definitely coming and while many were still preparing for the disaster, the eye of Iniki passed over Kaua'i shortly after 3:00 p.m. (HST). It brought devastation and destruction to the entire island, and between the 55,300 permanent residents and the 8,000-12,000 visitors on Kaua'i, there were only thirteen shelters established, mostly in high schools and neighborhood centers (Chiu, et al. 1995, 7). For those who did not stay at the established shelters, places of refuge included hotels and homes. Although there were various shelter locations, it was a

common requirement that all victims provide their own survival supplies. Common supplies that evacuees brought with them included food, water, blankets, clothes, pillows, and some form of entertainment. This information suggests that the proposed prototype should have the ability to be equipped with these goods or function in a way that provides similar amenities.



Figure 2. (Left) Due to the thousands of homes and various hotels destroyed, both visitors and residents find shelter at the Kapa'a Armory shelter. (Right) As residents begin to clean up after the hurricane, they take refuge in tents erected on their lawns.

The use of tents was very popular among the people of Kaua'i, and they proved to be efficient temporary shelters for disaster victims. With such a large amount of tent users, a tent should be redeveloped with intentions of informing a new direction in disaster relief. "It is estimated that about 6,000 people on Kaua'i were rendered homeless by Hurricane Iniki, with many of these people occupying shelters and tents for several weeks after the storm" (Chiu, et al. 1995, 92). According to Jan TenBruggencate of the *Advertiser* Kaua'i Bureau, "a fair proportion of the island had been forced to resort to some form of camping out." For some residents, living in tents on the lawns of their destroyed homes was preferred over leaving their Kaua'i properties and neighbors (Borg, et al. 1992, 38, 48). Others stayed in the homes of family and neighbors whose homes were more intact. A report by the Federal Emergency Management Agency shows that as of October 26, 1992, FEMA had provided 4,100 tents and 7,500 cots to Iniki survivors (Federal Emergency Management Agency 1992, 32).

Electrical power was disrupted for about ten weeks after the storm, causing long lines at gas pumps, worthless food stamps, cold showers, spoiled food, and high demands for ice, to name just a few problems. The storm left 4,545 (30%) wooden distribution poles lying on the ground, resulting in an island-wide blackout. On October

2, 1992, Walter Wright of the *Honolulu Advertiser* reported that “close to 20 percent of Kaua‘i Electric’s customers were back on yesterday” (Borg, et al. 1992, 88). For the remaining customers who did not have electricity, generators were used. Generators were in high demand as stock was quickly bought out and shipments were slow. To help address this problem, the military delivered a number of units, and business associates or friends of residents bought generators on other islands or on the mainland and shipped them to Kaua‘i (Borg, et al. 1992, 69). Another obstacle caused by the lack of electrical power was food preparation. With no electricity to power stoves, there was an increase in group barbecuing (Borg, et al. 1992, 40). Due to the community’s willingness to help each other, neighbors with working stoves or gas grills would invite individuals who were less fortunate to come eat. The loss of electricity affected a great number of things around the island, and suggested, among many other important lessons, that in addition to a few days worth of food, a flashlight and batteries should be included in an effective emergency kit.

Another essential item that should be included in an emergency kit is water. Prior to the storm, a lot of emphasis was placed on stocking up on water. People were urged to fill buckets and containers of water in case running water came to a stop, which is what happened following the storm. With people relying on their stashes of water, certain activities were limited. While people used water to drink, flush toilets, and bathe, other activities such as cooking and cleaning required careful use of water. For those who were running out of water, the U.S. military provided 611,107 (Joint Task Force Garden Isle 1992, 35) gallons of water, and the Salvation Army distributed 233 pallets of bottled water (Salvation Army 1992, 39).

Lack of information was another major problem immediately after the hurricane. All of the radio stations were knocked out, and KQNG, the designated Civil Defense station, was off the air for two days. When the station was finally operable, “radio [was] absolutely the best form of communication. It [was] faster and more thorough than anything else” (Ramirez 1992). Through KQNG, people were able to stop in to make requests for help since telephone lines were not working. According to Norman Ahu, manager of Kaua‘i’s GTE Hawaiian Tel, approximately 25,275 out of Kaua‘i’s 31,000 lines were out of service. On September 16, 1992 the first emergency phone banks were established (Ahu 1992, 47). With phone lines out, one of the key factors to survival on Kaua‘i was ownership of a radio, and thus, this item should be included in the prototype design.



Figure 3 (Left) "Rice Street in Lihue, Kauai is open to one lane of traffic after crews have shoved aside fallen utility poles that immediately blocked all traffic immediately after the hurricane" (Borg, et al. 1992, 81). (Right) "A Kekaha couple stands on a slab of Kaumualii Highway on Kauai's West Side. The hurricane lifted up sections of the road and washed a dense layer of sand over acres of yards near the shore" (Borg, et al. 1992, 57).

Throughout Kaua'i, the roads were torn up with some inaccessible to drivers and others full of debris. The morning after the storm, "drivers dodged debris and carefully made their way down the main street of Lihue" (Drivers Dodged 1992, 15). One unfortunate incident involved "Air National Guardsman Dennis Dalen, 46 of Hickam Air Force Base [who] was killed while on duty, when the state truck he was driving on Kuhio Highway in Waikoko, struck a hanging utility wire which caused the vehicle to flip over" (Mossman 1992, 22). This is an example of post-disaster driving hazards. To avoid such accidents, driving should be minimized until roads are reopened. While road blockages affect transportation, they also isolate victims and prevent survivors from finding refuge at shelters. For this reason, wearable disaster relief kits should be created to better accommodate the needs of stranded disaster victims.

During this devastating time of need, the necessities of individuals were minimal. Among the items considered necessary were food, baby food, water, ice, medicine, blankets, toilet paper, flashlights, lamps, batteries, can openers, radios, tents, and plastic tarps. To help fulfill these needs, many organizations donated these items. The U.S. military provided 9,422 rolls of plastic, 383,421 meals, 154 hours of Air Force support, 50 generators, removal of 58,000+ cubic yards of debris by Operation Garden Sweep, and the clean-up of 16 schools. The Salvation Army served 445,342 meals and distributed 68,824 food boxes, 45 generators, 9,931 pounds of medical supplies, 19,074 square feet of plastic tarp, and 2,548 bags of charcoal (Salvation Army 1992, 39). Many of these items can be considered when designing an effective emergency kit.

Aside from the many needs and problems that they experienced, the residents of Kaua'i responded rather well to this tragic event. Unfortunately, one of the things that could've been avoided was looting. On September 16, 1992, at least three people were arrested for looting and another 100 were being investigated with bail set at \$10,000 (Borg, et al. 1992, 59). There were only a small number of cases; however, this type of behavior was unnecessary, especially since the entire island experienced the same amount of suffering and pain. To help address this problem, emergency relief kits should include temporary shelters so that when possible, property owners can set up camp at their residences.

It seems almost impossible for island residents to escape a hurricane as it is impossible to drive far enough away. For the people of Kaua'i, preparedness was the only real protection from the disaster. However, even that proved to be inefficient as natural disasters do not discriminate against anything or anyone. Hurricane Iniki was the worst natural disaster to ever hit Hawai'i, and with the many lessons learned and changes implemented, many are hopeful that it will remain that way.

1.2 Hurricane Katrina

On August 29, 2005, Hurricane Katrina, the worst and most costly natural disaster to ever strike the United States, ravished the states of Louisiana, Mississippi, and Alabama. The extent of this natural disaster was extraordinary and unprecedented. According to the American Society of Civil Engineers, "as of August 2, 2006, 1,118 people were confirmed dead in Louisiana. Another 135 people are still missing and presumed dead. Thousands of homes were destroyed. Direct damage to residential and non-residential property is estimated at \$21 billion [and] damage to public infrastructure [is] another \$6.7 billion. Nearly half [of] the region's population has not yet returned after evacuating [and] nearly 124 thousand jobs were lost, [leaving] the region's economy crippled" (American Society of Civil Engineers Hurricane Katrina External Review Panel 2007, v).

The location of Hurricane Katrina enabled many people to escape the disaster zones. Unlike those who live on an island, people were able to drive to other states and take refuge at hotels or the homes of family and friends. A few days before the hurricane arrived, tens of thousands of people evacuated the city of New Orleans. However, many in the poorest and most vulnerable parts of the city, such as the lowest

lying parishes, did not leave, deciding to ride out the storm. While some people had an optimistic mentality that the storm was no threat as proven by previous hurricanes, others were deeply frightened, but were stuck with no transportation to leave. “According to the New Orleans Emergency Management Plan, roughly 100,000 residents of New Orleans, more than 20% of the entire city [did] not have cars or other means of personal transportation. Many of these same people [did] not have money for a bus, a train, or a hotel. Many depended on welfare checks, which tend to run out by the last few days of the month” (National Geographic 2005). For those who stayed in the city of New Orleans, it did not take long for them to realize the strength of the hurricane and the harm that followed.



Figure 4. “Overtopping and breaching at approximately 50 locations in the hurricane protection system led to destructive flooding that covered more than 80 percent of New Orleans” (American Society of Civil Engineers Hurricane Katrina External Review Panel 2007, 31).

Due to the large number of people who took refuge in the city and did not evacuate New Orleans, on the morning of August 28, 2005, the Louisiana Superdome was opened as a “shelter of last resort” (Freeman 2006). Mayor Nagin advised people to “come with enough food [and] perishable items to last at least three to five days. [Also] come with blankets [and] with pillows. No weapons. No alcohol. No drugs. Come like you’re going on a camping trip” (National Geographic 2005). The nearly 10,000 people who took shelter at the Superdome initially found security, medical facilities, food, and water. The building made everyone feel safe and secure. However,

after about a day, those feelings waned as Hurricane Katrina challenged the strength of the building and started to rip away the roof. In addition, on the morning of August 29, 2005, the electricity went out, stopping the air conditioning and forcing backup generators to provide reduced lighting (National Geographic 2005). From this point on, what was once a place of comfort and safety was a place of fear.



Figure 5. (Left) Thousands of people take refuge at the Louisiana Superdome where conditions quickly deteriorated. (Right) Military convoys drive through the high waters to distribute supplies of food and water.

On the morning of August 28, 2005 the Louisiana Superdome was opened and allowed evacuees to enter and take refuge. Mayor Nagin advised people to “come with enough food [and] perishable items to last at least three to five days. [Also] come with blankets [and] with pillows. No weapons. No alcohol. No drugs. Come like you’re going on a camping trip” (National Geographic 2005). For the nearly 10,000 people who took shelter at the Superdome, they found security, medical facilities, food and water. The building made everyone feel safe and secure. However after about a day that soon changed when Hurricane Katrina challenged the strength of the building and started to rip away at the roof. In addition to that, in the morning of August 29, 2005 the electricity went out, forcing the air conditioning to stop and back up generators to operate reduced lighting (National Geographic 2005). From this point on, what was once a place of comfort and safety was now a place of fear.

The commotion in the Superdome escalated, and to make matters worse, more chaos ensued as people who were rescued from their homes were brought there. The high water levels outside the building forced evacuees to arrive by rescue boats, military vehicles, and helicopters. Outside the building, the water was so high that the “trucks with fresh supplies of food, water and medicine [could not] approach the building” (National Geographic 2005). This caused many hungry people to become restless and

frustrated as help was at a standstill. With a growing number of people finding shelter here, the crowd increased to 20,000 people. For days, many people camped out at the Superdome, and as the hours passed, the conditions deteriorated. “The smells inside the dome were unfathomable. The running water and plumbing had long failed so people did what they had to do. They went to the bathroom in corners or used small brown bags that once contained military Meals Ready to Eat as makeshift toilets” (Freeman 2006). After the third day of camping out at the Superdome, the environment was inhuman and evacuation was becoming necessary. Based on the events that occurred here, it is clear that the established shelter set up by government officials was insufficient. Although there were supplies, they were quickly depleted and not adequately restocked. In addition, lacking building amenities and failing building conditions were inevitable as the shelter was located in a disaster zone.

Finally, in the late evening of August 30, 2005, Governor Kathleen Blanco “[called] for the full evacuation of the Superdome. With the area around the stadium flooded, transportation [was] a slow process. The plan [was] for buses to carry 20,000 people to the Houston Astrodome and other shelters. Tens of thousands of people [remained] trapped in New Orleans [and] some on the streets without basic necessities” (National Geographic 2005). As people awaited their rescue, they were faced with no food, water, or electricity, and scorching 90 degree heat.

The situation at the Louisiana Superdome offers a few suggestions for the proposed prototype. For instance, in the wake of the storm, the possession of at least food, water, medicine, and blankets brought some relief. Being prepared with those few items alleviated some concerns, especially when government supplies ran out and left people with nothing. From this, it is learned that the features of a disaster relief kit must include storage space for these items. Another major problem that people faced was that the flooding affected the entire city. This suggests that the proposed kit should incorporate a float device into the design. A third problem was the disrupted sewer system. A suggested solution to this dilemma is to research portable toilet devices.

The areas hit by Hurricane Katrina received untimely and slow aid. Due to the extent of the disaster, officials were unable to attend quickly to victims, and rescue efforts were so slow that by the time help arrived, many people had been starving and thirsty for several days. The flooding forced many people to sit on their roofs as they awaited rescue assistance. Another problem affected by slow rescue efforts was the ability to reach safe shelters. To some extent, the sluggishness was due to water levels

that were on average between 6 to 9 feet and that made rescue procedures challenging. In this situation, the factor that hindered people's ability to reach safe shelter was also why they were homeless.



Figure 6. (Left) A number of homes in Pearlington, Mississippi were destroyed, which forced many residents to sleep in tents. (Right) "When floodwaters rose high and fast, residents had nowhere to go but up. Once water levels topped windows and doors, residents hacked through their roofs to await rescue" (American Society of Civil Engineers Hurricane Katrina External Review Panel 2007).

As previously stated, unlike those who live on an island, many residents and tourists in the expected path of Hurricane Katrina were fortunate and able to evacuate and find refuge outside of the disaster zone. The experiences of those who decided to stay in the city revealed a great deal of information about the issues that victims face in the event of a natural disaster, which will be an excellent reference for the design of the proposed prototype.

1.3 American Samoa Earthquake and Tsunami

On September 29, 2009, an 8.0 magnitude earthquake in the South Pacific generated a tsunami that made landfall on the islands of Western Samoa, American Samoa, and Tonga. In American Samoa, the waves wiped out and flattened many villages, especially those located on the western point of the island. "The ensuing tsunami killed nine people in Tonga, 149 in the independent country of Samoa, and 34 in American Samoa. It was the deadliest tsunami in the Samoa region in living history. The damage in Samoa alone exceeded \$150 million" (Samoa Earthquake and Tsunami of September 29, 2009 2010).

The destructive waves came as a surprise for many, especially since the first

tsunami warning came after the first wave had already hit (Nakaso 2009). Minutes before the wave swept ashore, many villages felt an earthquake that occurred about 120 miles away. For some, the quake served as a natural tsunami warning, however, not everyone escaped in time. Others became aware when the water started to recede, which prompted people to run uphill. With delays in the warning system and natural tsunami warnings occurring only minutes before its arrival, people were unable to prepare for this disaster, therefore suggesting that designated emergency shelters should have emergency relief kits on hand to distribute to victims. These emergency shelters should be located throughout all parts of the island, especially since road blockages may cause problems.



Figure 7. "People walk among a scene of devastation following a powerful earthquake in Pago Pago village, on American Samoa. The quake in the South Pacific hurled massive tsunami waves at the shores of Samoa and American Samoa, flattening villages and sweeping cars and people back out to sea while leaving scores dead and dozens missing" (Fox News 2009).

To further explain the issues associated with road blockages, the damages inflicted on the roads and bridges are described. The terrible road conditions delayed help and access to certain areas of the island. For those on the western end, where a majority of the hard hit villages were located, access was almost impossible due to damage done to the main road. According to Governor Tulafono, the road damages made "relief and assistance very, very difficult in a very populous area of the main island. A major connecting bridge in the middle of [the] bay area was destroyed and the efforts to get people from one side of the bay to the other were heavily compromised

because of that. Manual labor had to be used to transport injured and fatalities across the bridge to the other side, where help was waiting to evacuate them” (Nakaso 2009). The lack of preparation and extent of road damage emphasize the need for strategically established shelters equipped with emergency disaster kits. Another option would be to equip households with these kits. However, the homes of those needing the kits most may be washed away. For that reason, the price of these kits should be reasonable and affordable, so that if they are washed out, the loss is not financially significant.



Figure 8. (Left) Volunteers from the American Red Cross erected yurts for families whose homes were lost or damaged due to the massive waves. (Right) The American Red Cross distributed Jumpstart to Recovery kits “to help disaster victims with their short-term, immediate requirements, as well as aid for the long term” (Chawla 2009).

A far larger problem than damaged roads was the people left homeless. According to the Red Cross, “the tsunami destroyed or damaged the homes of at least 2,000 families” (American Samoa Recovery Operation 2009). Of those families, “more than 2,000 people [stayed] in 17 temporary shelters [and] hundreds more [stayed] with family or friends or at informal shelters. Many of the shelters [were] largely empty during the day, as people [tried] to clean up their homes and businesses and [waited] for disaster relief officials to conduct damage assessments” (DePledge 2009). Following these assessments, American Red Cross workers [erected] “yurts – round tents that can be erected on a family’s land after the American Samoa government has certified that the property has been cleared of debris and has adequate sanitation systems” (American Samoa Recovery Operation 2009). While the yurts proved to be an extremely helpful commodity, the response was not immediate. As of October 4, 2009, a village in a remote area called Amanave was still waiting for government officials to

assess the damage. A village resident named Sulia Tautalafuna shared that she lost everything and didn't know how to survive, so [she was] waiting for help from the government. The yurts definitely gave victims hope and a way of surviving, however, a recommendation would be to develop a kind of wearable yurt with the ability to expand by connection to other yurts.

Another excellent commodity provided and distributed by the American Red Cross was Jumpstart Kits. Jumpstart Kits are backpacks that include “two blankets, a combination hand-crank radio, flashlight, and cell phone charger, a mesh laundry bag, a first aid kit, notepad and pen, work gloves, face masks and a bath-in-a-bag. The kits have items for comfort, wellness and communication – things you need immediately after a disaster. The Jumpstart to Recovery kit also provides a disaster victim with useful information including a *Picking Up the Pieces* booklet which describes the recovery process and a *Helping Children Cope With Disasters* brochure to assist even the youngest disaster victims in the healing process” (Chawla 2009). All items were equally important, and with no electricity and broken telephone poles and lines, the cell phone charger provided an effective communication tool. Again, although the kits provided great relief and recovery resources, they were not immediately available; they arrived in American Samoa on October 17, 2009. Had they been accessible to victims within hours or at most a day after the disaster, the Jumpstart Kits would have been even more effective.

The four tsunami waves wiped out everything in their paths and left victims with almost nothing. To meet people's needs, life-sustaining supplies and donations were made by many organizations including the American Red Cross, the U.S. Coast Guard, FEMA, and other non-profit organizations. The donations were comprised of food, baby food, water, generators, candles, blankets, medical supplies, and tarps to name a few. These popular items that were delivered and distributed to survivors reveal what the critical needs of victims were and thus become of great use when designing a wearable emergency relief kit.

1.4 Conclusion

In this study, the claim that user-led wearable disaster relief kits are necessary in times of a natural disaster has been strongly supported by the data collected from Hurricane Iniki, Hurricane Katrina, and the American Samoa tsunami and earthquake.

The information gathered has revealed a number of issues and needs that survivors experience upon anticipation and arrival of a natural disaster. Due to the vast amount of material discovered, a Natural Disaster Cause & Effect Chart has been created, see Figure 9. This chart organizes all of the issues encountered as a result of the disaster as well as the effects that these issues have on the community. Subsequently, it displays the common needs of victims and offers potential solutions that can be integrated into a wearable disaster relief kit. In addition to this chart is a Natural Disaster Issue vs. Need Matrix, see Figure 10, which reveals the needs of natural disaster victims according to the issues faced.

This analysis of natural disasters shows that the issues prior to the disaster include the warning system and preparation, equipment and food storage, and resistance to evacuation. In all case studies, preparation has proven to be both a useful and useless tool in addressing disaster concerns and stress. While preparation is sometimes the only real defense, other times, it is far too weak to challenge the strength of a catastrophic event. Regardless, preparation must always be practiced, and it is argued that a user-led disaster relief kit should be developed and used when preparing for a disaster. Based on research and observation, it is believed that the wearable disaster relief kit must be designed for use before, during, and after the disaster. Before the disaster, the prototype can be used to store items, and thus can be equipped with food, clothes, valuables, important documents, and other life-sustaining items. During the disaster, individuals will be able to wear the kit and make use of the items stored in it. Immediately following the disaster, before government housing is issued, is when the prototype will be used as a shelter.

The American Samoa earthquake and tsunami proved that some people either have no warning or only last minute warning that does not warrant enough time for preparation. It has been suggested that the proposed prototype must be simplistically designed so that it will be easy to dress into upon short notice. However, the issue is the lack of warning and time provided to react rather than the design of the prototype. For that reason, it is clear that there are some situations and events that are out of the scope of the proposed prototype.

The last pre-disaster issue brought up by these examples, particularly Hurricane Katrina, is resistance to evacuation. Unlike residents and visitors located on an island, the people threatened by Hurricane Katrina were not trapped and forced to stay in the disaster zone. While many people who took refuge in the disaster zone had various

reasons for their decision, it is advised to evacuate and avoid the anticipated disaster zone. Staying clear of the disaster's path increases a person's ability to survive as well as provides people with a safer and more comfortable environment.

There were also several post-disaster issues. Unlike the issues experienced prior to the disaster, the majority of the post-disaster issues were only resolved with the availability of tangible objects. This means that in order to remedy the problem, it was essential for the object to be present. For instance, in all three disasters, there were displaced individuals whose homes were either destroyed or damaged. There were a few solutions to this problem: relocate to a shelter or friend/family member's home, resort to some form of camping out, or take refuge in the yurts distributed by the American Red Cross. All of these solutions were tangible, and in the event that a displaced victim didn't have one of these options, then his or her problem went unsolved.

This idea runs parallel with the other post-disaster issues that arose. With analysis of the various disrupted services and technologies that were provided by the government, some of the other necessities can be understood. These damaged amenities included electrical power, sewer systems, running water, communication, and roads. These issues not only affected people's private lifestyles, but also public activities. Due to the lack of electricity, disruptions included cold showers, absent lighting, useless stoves, and powerless refrigerators. In addition to these daily inconveniences, victims were unable to use credit cards or food stamps to purchase products at stores, and gas stations were out of service. As a result, generators, ice, flashlights, batteries, and lamps became popular commodities and barbecues were used heavily to cook. Due to the disrupted sewer system, many people relied on bags as makeshift toilets, which suggests that portable toilet devices should be included in the wearable disaster relief kit. Another tool that should be considered is a water purifier as there was a lack of clean running water and thus, people were forced to wait for donations by government and non-government organizations. A third tool that should be considered is a radio or a combination hand-crank radio, flashlight, and cell phone charger. Due to broken telephone poles and water damage, communication was often slow in the disaster zones. The last disrupted technology was the roads, which were often destroyed or blocked by fallen utility poles and debris, torn up asphalt, and flooding. As a result, a number of people were killed, survivors were left stranded without life essentials (such as food and water), survivors were blocked from finding refuge at shelters, and medical assistance was slow. This collection of data uncovers

the various tangible needs that victims experienced after three natural disasters. Relating this information back to the issue of storage, it is argued that many of these problems could be solved with the preparation and availability of an equipped user-led wearable kit. In the event that a victim has a device with enough space to store these tangible needs, his or her recovery efforts will transpire more smoothly.

In addition to the disrupted services that were addressed by the government, there were a couple of other issues. These include the looting experienced in all three disasters and the flooding of Hurricane Katrina. While there were some cases of looting for purposes of taking food and supplies needed for survival, other times, it was an act of selfishness. It would be ideal for victims to reside adjacent to their damaged or destroyed homes by using the shelter feature of the wearable disaster relief kit. It is argued that this will prevent and deter looters from entering into other people's homes and thus, keep their valuables safe. As for the flooding issue that left survivors trapped and stranded for days in New Orleans, even causing some people to die, it is recommended that a float device be incorporated into the kit. This feature will increase a disaster victim's chances of survival of dangerously high waters as well as help bring victims to a safe place of refuge.

This analysis of natural disasters shows that no two disasters are the same; however, research has proven that regardless of the type of disaster, there is one consistent and common issue: the needs of people. Throughout each event, the needs of people were generally the same, and to everyone's dismay, the availability of supplies was rather low as services at all levels were disrupted. It is realized that there are many needs that arise upon notification and arrival of a natural disaster. However, there are certain needs that are more important than others. The data collected does not reveal the hierarchy within this list of needs, but it will be determined upon completion of the investigation on minimalist shelters. It is not guaranteed that all of these needs will be incorporated into the design of the prototype, however, all will be considered and only those that are truly crucial will be integrated.

At this point, without conducting tests and examinations, it is incorrect to assume that the proposed prototype would have been a significant help during Hurricane Iniki, Hurricane Katrina, and the American Samoa earthquake and tsunami. However, in the case of the American Samoa earthquake and tsunami, the events that followed and the items that were passed out following the disaster are similar to the proposed use and features of the prototype, and therefore begin to further support the idea that the

prototype will be of great use during natural disasters. For instance, yurts and Jumpstart to Recovery kits were distributed by the American Red Cross as they have “learned that getting tangible items into the hands of disaster victims soon after a disaster is widely appreciated and quickly gets people on the road to recovery. [It was] the first time such a resource [had] been distributed by the Red Cross. Research conducted by the American Red Cross in April 2009 with prior disaster victims shed some light on what disaster victims needed in the wake of devastation. They said their critical needs were clear information about the disaster situation and available relief and recovery resources” (Chawla 2009). The American Red Cross is one of the first organizations to develop a recovery kit, which has similar intentions to those of the wearable disaster relief kit. The procedures and steps taken to execute the Jumpstart kit are also quite similar, with the only downside being that it is not passed out immediately after a natural disaster. So while the job done by the American Red Cross is a leap in the solutions to disaster relief, it still has some constraints that need to be addressed.

As described in each event, natural disasters clearly leave individuals with a great amount of need and high stress levels. In most situations, survivors are left with only a few life-sustaining supplies to live off of before any type of assistance arrives. This leaves the majority of people feeling hopeless, confused, and scared. In an attempt to avoid this situation from happening in the future, a wearable disaster relief kit will be designed. Research was thus directed towards the needs of people in order to effectively determine the features of the proposed prototype.

NATURAL DISASTER CAUSE & EFFECT CHART



		HURRICANE INIKI	HURRICANE KATRINA	SAMOA EARTHQUAKE & TSUNAMI		
						
					NEEDS	SUGGESTED SOLUTION
ISSUES PRIOR TO THE DISASTER	WARNING SYSTEM	Unclear advisory and short message delivery caused people to feel unprepared		Warnings occurred minutes before its arrival so people were unable to prepare	<ul style="list-style-type: none"> Free education and information on natural disasters 	Garment must be easy to dress into and designated emergency shelters should have relief kits on hand
	STORAGE	Emergency shelters require occupants to bring their own survival supplies	Emergency shelters require occupants to bring their own survival supplies	Emergency shelters require occupants to bring their own survival supplies	<ul style="list-style-type: none"> Backpack 	Design a pocket system to store basic necessities
	RESISTANCE		Find refuge in the disaster zone		<ul style="list-style-type: none"> Free transportation to shelters out of the disaster zone 	If possible, especially when not trapped on an island, it is best to evacuate disaster zones
	POWER OUTAGE	Caused long lines at gas pumps, worthless food stamps, cold showers, spoiled food, high demands for ice. People used generators and barbecued	Relied on generators	Relied on the combination hand-crank radio, flashlight and cell phone charger distributed by the American Red Cross	<ul style="list-style-type: none"> Generators Ice Flashlights Batteries Lamps Combination Hand-crank Radio Flashlight and Cell Phone Charger 	Carry a lighting device
ISSUES AFTER THE DISASTER	DISPLACED INDIVIDUALS	Forced people to resort to some form of camping out, such as tents	Relocated to other shelters around the United States	Relocated to designated and informal shelters, stayed with family or friends, and took refuge in the yurts distributed by the American Red Cross	<ul style="list-style-type: none"> Tents Plastic Tarp Yurts 	Design a garment that transforms into a shelter
	DISRUPTED SEWER SYSTEM		People went to the bathroom in corners or used small bags as makeshift toilets		<ul style="list-style-type: none"> Package Toilet Paper 	Design or purchase a toilet device
	NO RUNNING WATER	Buckets and containers of water were filled, US Military and Salvation Army distributed water, people showered at Opaekaa Falls	Waited for the government to distribute bottled water	Victims relied on facilities that were not damaged and others waited for the government to distribute bottled water	<ul style="list-style-type: none"> Water 	Design a pocket system to store basic necessities and research devices that purify water
	COMMUNICATION	Broken telephone poles caused survivors to heavily rely on radio station		Broken telephone poles	<ul style="list-style-type: none"> Radio Combination Hand-crank Radio, Flashlight and cell phone charger 	Carry a radio
	DAMAGED ROADS	Prevented survivors from finding refuge at a shelter	Left survivors stranded for days	Left survivors stranded for days	<ul style="list-style-type: none"> Food Water Medical Assistance 	Design a pocket system to store basic necessities Designated emergency shelters should have relief kits on hand
	LOOTING	Personal belongings were stolen	Personal belongings were stolen	Personal belongings were stolen	<ul style="list-style-type: none"> Reside near property 	Design a garment that transforms into a shelter, therefore allowing survivors to take refuge adjacent to their homes
	DEFICIENT AMOUNT OF SUPPLIES	Community shared, government and non-government agencies distributed supplies	Left survivors starving and thirsty for days	Jumpstart to Recovery Kits distributed by the American Red Cross	<ul style="list-style-type: none"> Water Food Medicine Can Opener Jumpstart to Recovery Kit 	Design a pocket system to store basic necessities
	FLOODING		Left survivors trapped for days		<ul style="list-style-type: none"> Design a floating device 	Design a floating device

Figure 9 Natural Disaster Cause & Effect Chart

NATURAL DISASTER
ISSUES VS. NEEDS

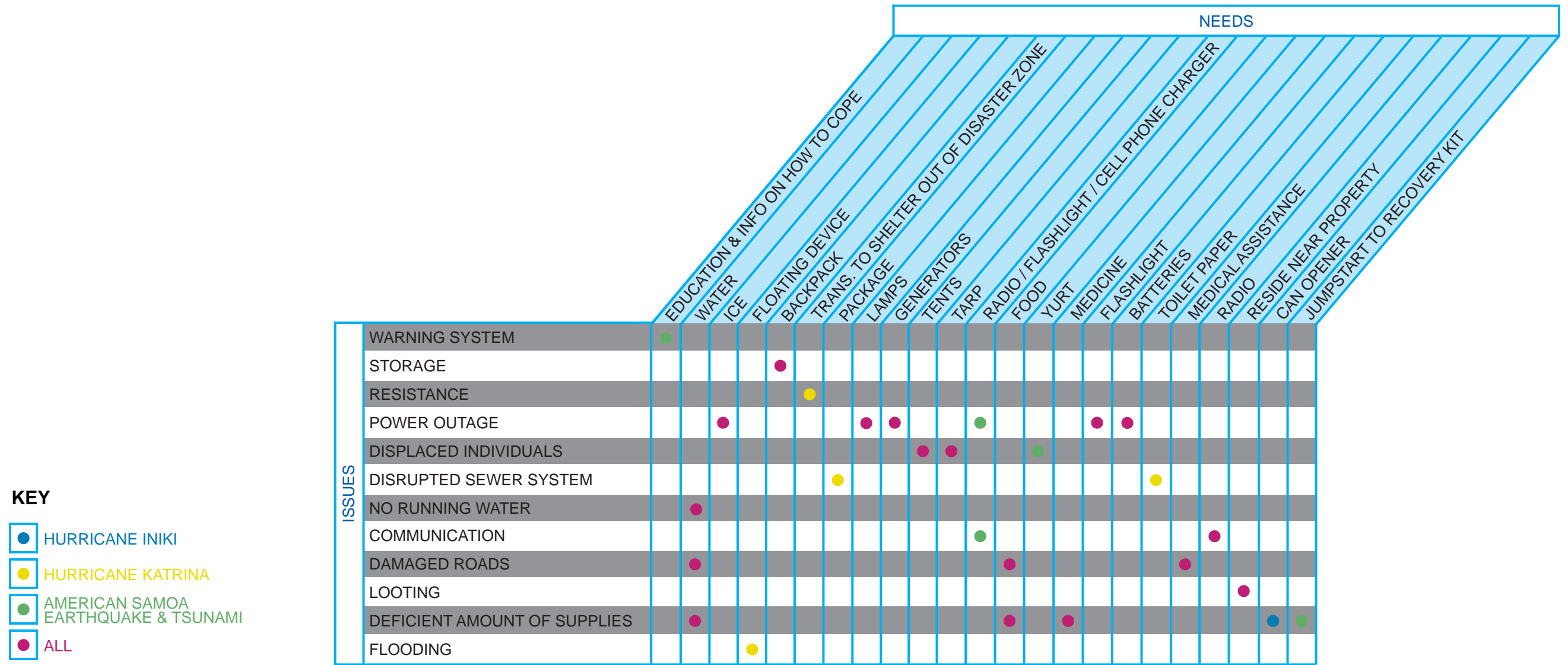

Figure 10. Natural Disaster Matrix. This matrix reveals the needs of natural disaster victims according to the issues faced.

Chapter 2

Minimal Structures

People's responses to natural disasters reveal substantial and significant information that should be considered in designing a wearable disaster relief kit prototype. In addition to post-disaster necessities, there are other necessities for everyday survival. In order to establish what everyday survival necessities are, a study of minimal structures will be assessed. Minimal structures include dwellings that more or less provide inhabitants with the things necessary for survival. These buildings will be studied because unlike the current homes of thousands of people, they do not typically contain lavish and entertaining spaces and objects. Instead, they are developed to provide people with only basic survival supplies. Research will be geared towards indigenous shelters, low-income housing, and spaces of the homeless.

Indigenous shelters reflect a lot of information about resourceful individuals whose lifestyles consist of low-tech practices. The skill level of these people, whether simple or complex, influences the type of dwelling used. While some find survival attainable through a portable life that is constantly on the move, others have discovered more sophisticated survival skills that do not require constant mobility. Their techniques and ways of life may seem outdated; however, they are inventive and successful. Regardless of the category and refinement of the people, they each share certain qualities that emphasize the necessities of survival. In addition, indigenous shelters were often developed for survival in pre-urban life, which in some cases is what the environment looks like after a natural disaster.

Following the pre-urban house is the urban house, which includes low-income housing. Low-income housing is defined as government-assisted housing for people with a low annual household income. Although this type of housing is a permanent settlement, which is completely opposite from the proposed prototype, the information

gathered is still helpful. Essentially, it is an analysis of underprivileged people who struggle to provide for their families and like indigenous people, survive with the basic necessities of life.

Indigenous shelters and low-income housing both provide people with a sense of home and also reveal information about the basic necessities for everyday survival. However, due to their ability to provide a roof over people's heads, indigenous shelters and low-income housing fail to provide information on the necessities of people without homes, such as the homeless. "Homelessness is typically thought of in terms of a lifestyle characterized first and foremost by the absence of conventional permanent housing" (Snow and Anderson 1993, 7). Due to their lack of home ownership, homeless dwellers become true role models for displaced people after natural disasters. Many lessons can be learned from their lifestyle as they are mobile people who do not rely on the benefits of a house.

The examples researched range widely in the type of dwelling forms used, however, the similarities found throughout indigenous shelters, low-income housing, and homelessness begin to inform what people need for survival. With this information, the considerations that should be incorporated in the design of the prototype will be revealed.

2.1 Indigenous Shelters

Indigenous peoples are people, societies, and bands that are aboriginal to a specific location and are found throughout all parts of the world. Their way of life, practices, and beliefs are (at times) looked upon as rudimentary compared to the urban person, however, for that particular reason, this research is very valuable. More specifically, this research will focus on the dwellings of these people and how they function and meet the needs of their inhabitants. This information will reveal features that should be considered in the prototype and thus will be of great importance during the design phase. A number of pre-urban indigenous shelters have been selected for review including the African Bushmen skerm, the BaMbuti Pygmy hut, the Inuit tupiq, Plains Indian tepees, the Kirgiz yurt, the Bedouin black tent, the Masai boma, the Navaho hogan, and Mesakin Quisar cluster dwellings. They have been organized according to a system developed by Norbert Schoenauer who suggests that

...to study the hierarchy of pre-urban indigenous dwelling types, a primary classification similar to that used by Gabriele Schwarz in her Allgemeine Siedlungsgeographie [be adopted]. The categories that emerge for such a system include:

- 2.11 Ephemeral or transient dwellings – the dwellings of nomadic band-type societies whose existence depends on a simple hunting/food-gathering economy*
- 2.12 Episodic or irregular temporary dwellings – the dwellings of nomadic band-type societies whose existence depends on either advanced hunting or advanced food-gathering practices; the former is a stepping-stone to pastoralism and the latter to rudimentary agriculture*
- 2.13 Periodic or regular temporary dwellings – the dwellings of nomadic tribal societies with a pastoral economy*
- 2.14 Seasonal dwellings – the dwellings of tribal societies with a semi-nomadic way of life based on both pastoral and marginal agricultural pursuits*
- 2.15 Semi-permanent dwellings – the dwellings of sedentary folk societies or hoe peasants practicing subsistence agriculture (Schoenauer 2000, 11-12)*

In addition to this system, another system has been created in an effort to organize the information found about each dwelling. The following criteria have been used to understand and analyze each shelter: 1. Description, 2. Location, 3. Weather, 4. Lifestyle, 5. Shelter Materials, 6. Portability, 7. Construction, 8. Spatial Organization, 9. Ventilation, 10. Lighting, 11. Unique Features, and 12. Needs. Using these categories, the fundamentals as well as details about each indigenous shelter will be revealed. This information will uncover characteristics that may be relevant and applicable to the proposed prototype. It will also reveal indigenous features that are worth duplicating and modifying.

In order to efficiently share the data collected on the nine pre-urban indigenous shelters, a chart based on the two classification systems has been composed. This chart represents the data collected without much analysis. Following this chart, are further explanations and analyses of each shelter.

INDIGENOUS SHELTERS CHART

	AFRICAN BUSHMEN SKERM	BAMBUTI PYGMY HUT	INUIT TUPIQ	PLAINS INDIAN TEPEES
				
DESCRIPTION	Small grass shelters of the Kung Bushmen who gather their materials on site. Diameter = 7.5 ft	Beehive hut, made of Mongongo leaves, for the BaMbuti people. Diameter = 7.5 ft	Summer dwelling of the Inuit people. Dimensions = 12 ft x 8 ft	Tepees occupied by Indians that on average "was 10 to 12 ft high and had a diameter of 12 to 15 ft" (Schoenauer 2000, 30).
LOCATION	Kalahari Desert	Kalahari Desert	Central Arctic of Canada	North American Great Plains
WEATHER	Arid	Tropical rainforest	Summer consists of moderate to warm daytime temperatures	Very cold winters and very hot summers
LIFESTYLE	<ul style="list-style-type: none"> • Hunter-gatherer • Migrate on a regular basis in pursuit of food 	<ul style="list-style-type: none"> • Hunter-gatherer • Migrate on a regular basis in pursuit of food 	<ul style="list-style-type: none"> • Skilled seal hunters • Period of shelter use generally consists of several weeks; two distinguished dwelling types (one for summer and one for winter) 	<ul style="list-style-type: none"> • Skilled buffalo hunters • Period of shelter use generally consists of several weeks
SHELTER MATERIALS	<ul style="list-style-type: none"> • Branches • Grass • Sinew 	<ul style="list-style-type: none"> • Mongongo leaves • Sapling 	<ul style="list-style-type: none"> • Seal skin • Poles • Stone 	<ul style="list-style-type: none"> • Poles • Buffalo hide • Stones
PORTABLE	No	No	Yes	Yes via travois
CONSTRUCTION	Dome structural skeleton made of branches and covered with grass and sinew.	Dome structural skeleton made of saplings and covered with layers of mongongo leaves.	Structural skeleton made of poles and sealskin cover is placed over.	Conical structural skeleton made of poles and covered with buffalo hide.
SPATIAL ORGANIZATION	<ul style="list-style-type: none"> • Circular footprint • Open floor plan with an outdoor fire 	<ul style="list-style-type: none"> • Circular footprint • Open floor plan with an outdoor fire 	<ul style="list-style-type: none"> • Rectangular footprint • Open floor plan with a bed 	<ul style="list-style-type: none"> • Circular footprint • Beds located adjacent to the walls • Altar and hearth in the middle • Wood next to entrance
VENTILATION	Yes via shelter entrance	Yes via shelter entrance	Yes via shelter entrance	Yes via shelter entrance
LIGHTING	Natural	Natural	Natural	Natural
UNIQUE FEATURES	<ul style="list-style-type: none"> • Overlapping sealskin doors prevent the wind from entering the shelter 	<ul style="list-style-type: none"> • Second layer of buffalo hide helped to insulate the interior spaces and prevent wind from entering through the bottom edges • Took an hour to pitch up and less than an hour to take apart 	<ul style="list-style-type: none"> • Walls can be easily folded up 	<ul style="list-style-type: none"> • Roof-line is flat in order to protect against the winds and sandstorms • Black-tent is appropriate for climate as it is not entirely waterproof, yet it provides protection from the sun and keeps occupants cool
NEEDS	<ul style="list-style-type: none"> • Shelter • Food • Water • Warmth 	<ul style="list-style-type: none"> • Shelter • Food • Water • Warmth • Comfort • Protection from the elements 	<ul style="list-style-type: none"> • Shelter • Food • Warmth • Comfort 	<ul style="list-style-type: none"> • Shelter • Food • Warmth • Comfort

Figure 11a Indigenous Shelters Chart

INDIGENOUS SHELTERS CHART





	KIRGIZ YURT	BEDOUIN BLACK-TENT	MASAI BOMA	NAVAHO HOGAN	MESAKIN QUISAR CLUSTER DWELLING
					
DESCRIPTION	Home of the Mongolian people Diameter = 10 to 20 ft Height = 4 ft	Tensile structure for the Bedouin people. Length = 20 to 30 ft Dept = rarely more than 10 ft Height = 5 to 7 ft	Low ceiling huts occupied by the Masai tribes. Width = 7 to 10 ft Length = 10 to 13 ft	Dwelling occupied by the Navaho "is a low, one-room, mud-covered log hut with a doorway facing the east" (Schoenauer 2000, 50). The floor plan is circular and is depressed 2 ft below grade.	Dwelling for the Mesakin Quisar. It functions very similarly to a typical house as it has rooms and spaces for separate functions, walls that are from 7 to 10 ft high and a conical grass roof.
LOCATION	Steppes of Central Asia	Western Asia and North Africa	Plains of Kenya and Tanzania	Southwestern United States	the Sudan
WEATHER	Winters are intensely cold and summers are warm with cold nights	Very hot days and cold nights	Arid	Arid	Tropical
LIFESTYLE	<ul style="list-style-type: none"> Pastoralists 	<ul style="list-style-type: none"> Herdsmen that roam with their livestock through the desert 	<ul style="list-style-type: none"> Pastoralists who abandon their dwellings when waterholes are dry 	<ul style="list-style-type: none"> Seminomads who depend on cultivated plants and domesticated animals 	<ul style="list-style-type: none"> Hoe peasants
SHELTER MATERIALS	<ul style="list-style-type: none"> Khana: lightweight willow latticework Roof poles Stone Mundahs: heavy felt 	<ul style="list-style-type: none"> Poles Ropes Black cover made of goat hair 	<ul style="list-style-type: none"> Posts Saplings Twigs Leaves Grass Cow dung Mud 	<ul style="list-style-type: none"> Earth Branches and posts from trees 	<ul style="list-style-type: none"> Adobe Mud Woven grass Boughs
PORTABLE	Yes via pack animals	Yes	No	No	No
CONSTRUCTION	Structural skeleton made of khana (walls) and poles (roof) and covered with mundahs	Tensile structure	Structural skeleton made of posts and saplings; Twigs, leaves and grass are integrated into the framework; Using the cow dung and mud a plaster is created to cover the framework	Dome structural skeleton made of branches and posts and covered with moist earth	xxx
SPATIAL ORGANIZATION	<ul style="list-style-type: none"> Circular footprint Open floor plan with space division of men and visitors on one side and women on the other side Fire in the middle 	<ul style="list-style-type: none"> Living area Working area Reception 	<ul style="list-style-type: none"> One third is occupied by young animals Remaining area consists of the living area with a hearth and beds 	<ul style="list-style-type: none"> Circular footprint Open floor plan 	<ul style="list-style-type: none"> Sleeping hut for the parents Children's loft Shower Cooking place Storage space Granary Animal pen
VENTILATION	Yes via shelter entrance	Yes via shelter entrance	Yes via shelter entrance	Yes via shelter entrance	Yes via shelter entrance
LIGHTING	Natural	Natural	Natural	Natural	Natural
UNIQUE FEATURES	<ul style="list-style-type: none"> Walls can be easily folded up 	<ul style="list-style-type: none"> Roof-line is flat in order to protect against the winds and sandstorms Black-tent is appropriate for climate as it is not entirely waterproof, yet it provides protection from the sun and keeps occupants cool 		<ul style="list-style-type: none"> "Diurnal extremes of temperature of the region are evened out by the lag in heat gain and heat loss of the thick layer of mud covering" (Schoenauer 2000, 50-51). 	<ul style="list-style-type: none"> Specific huts for specific functions "Base is carefully prepared to allow rain water from the inner courtyard to drain off easily" (Schoenauer 2000, 60).
NEEDS	<ul style="list-style-type: none"> Shelter Food Warmth Comfort Privacy Storage Protection from the elements 	<ul style="list-style-type: none"> Shelter Food Privacy Safety Storage Protection from the elements 	<ul style="list-style-type: none"> Shelter Food Water Warmth Privacy Comfort Protection from the elements 	<ul style="list-style-type: none"> Shelter Food Comfort Protection from the elements 	<ul style="list-style-type: none"> Shelter Food Privacy Comfort Storage Hygienic Procedures Protection from the elements

Figure 11b Indigenous Shelters Chart

2.11 Ephemeral or Transient Dwellings



Figure 12 (Left) African Bushmen skerm (Right) BaMbuti Pygmy hut. Both shelters are made of materials that are gathered onsite and are used for only a few days.

“The simplest dwelling types are ephemeral or transient dwellings. As their name indicates, these dwellings generally are not used for more than a few days since their inhabitants are primitive food gatherers and lowly hunters, constantly on the move in an endless pursuit of food” (Schoenauer 2000, 14). The two ephemeral dwellings studied are the African Bushmen skerm and the BaMbuti Pygmy hut. Although their territories differ with the Kung Bushmen located in the arid Kalahari Desert and the BaMbuti people in the tropical African Ituri Forest, there are a few similarities between the two. To begin with, their shelters are straightforward and all materials can be gathered onsite. The floor plans are circular with a dome-shaped roof, and the interior of the dwellings consists of an open space that is accessible through the only opening, which is the door. The materials used to erect the dwellings are minimal with branches, grass, and sinew used for the Bushmen skerms and mongongo leaves and saplings for the Pygmy huts. Interior climate control for both is very basic; there is an outdoor fire located near the shelter.

While the lifestyles of the Kung Bushmen and BaMbuti people are similar, there are unique characteristics that set the two bands apart. The Kung Bushmen are known to live a communal life where “they share food and all material goods. It is unthinkable that a Bushman would refuse to share food or water with his other band members. Without this rigid cooperation, they could not survive the famines and droughts that frequently occur in the Kalahari desert. Their few material possessions are freely shared among the members of this nomadic group in order to prevent jealousies and hostility” (Schoenauer 2000, 16). As for the BaMbuti people, they are known to be “clean people [who] do not like to sit on the bare ground. Most often they sit on logs, even on the end

of a log that is sticking out of a fire. Sometimes they pull a mongongo leaf from the roof of the nearest hut and sit daintily on that” (Schoenauer 2000, 18-19). Another trait that the BaMbuti people are known for is their shelter construction. As mentioned earlier, their huts consist of mongongo leaves and saplings. By layering mongongo leaves over the structural saplings, they prevent rain from entering the hut. Also, unlike African skerms, the BaMbuti Pygmy huts are expandable.

Based on their way of life and the type of shelter occupied, it is understood that the needs of the Kung Bushmen are shelter, food, water, and warmth. The BaMbuti require shelter, food, warmth, and comfort. While both dwellings suit the needs of the Kung Bushmen and the BaMbuti people, they are too primitive for the proposed prototype. In the aftermath of a disaster, survivors should have a ready-to-construct shelter instead of a primitive dwelling dependent on the surrounding natural materials. Relying on the leaves and branches of trees may increase the stress level of survivors and give false hopes of a sufficient shelter.

Aside from their selection of shelter material, there are other viable features and practices that can be borrowed beginning with the use of a fire to keep warm at night. This is a simple and common solution that is not only used by indigenous tribes, but by the urban person as well. It is a great and relatively simple way to control the climate when your shelter cannot. Another noteworthy feature of these shelters, more specifically the Pygmy hut, is the ability to expand into a larger space. This is a great characteristic because when the hut gets too small, it can continue to grow and thus, accommodate large groups. The third commendable practice is the Kung Bushmen’s habit of sharing. In the event of a disaster, the acts of sharing and giving are measures that help the recovery process run more smoothly. Of course, it isn’t the best solution to rely on others for help nor is it always possible to give to others, however, when possible sharing should be practiced. Lastly, the BaMbuti people’s emphasis on cleanliness sheds light on comfort issues. Although the Bambuti people find it comforting to sleep on leaves or sticks as it is a way to avoid sleeping on the ground, the urban person would probably not find that very comforting and an alternate approach should be considered.

2.12 Episodic or Irregular Temporary Dwellings



Figure 13 (Left) Summer house of the Inuits. During the cold months the Inuits occupy igloos and during the warm months they dwell in tupiqs. (Right) Plains Indian tepee. By using the parts of the buffalo, the Indians are able to construct their dwelling and survive in the Great Plains.

“Like the ephemeral dwellings, simple episodic or irregular temporary dwellings are shelters inhabited by food gatherers and hunters living in a band type of social organization. These nomadic bands, however, are skilled hunters or fishermen living in a richer environment than that of the [ephemeral or transient dweller] hunters. They are primarily hunters (or fishermen) and only secondarily food gatherers. Although their shelter is erected within an hour or two, the period of use generally extends to several weeks rather than to several days” (Schoenauer 2000, 22). The two episodic dwellings studied are the Inuit tupiq and the Plains Indian tepees. It has been noted by Schoenauer that although the Inuits and Plains Indians are only slightly more advanced hunters than the Kung Bushmen and BaMbuti people, there are significant differences in shelter forms including the number of dwelling types owned, the size of the shelter, and the ability to control the interior climate. With their skills, these people were able to construct more simple and effective shelters that required only a few assembly steps.

The Inuits and the Plains Indians share at least one similarity, but overall, have many differences. The similarity is the fact that both bands follow and primarily hunt a specific animal. The Inuits (also known as Eskimos) follow seals, and the Plains Indians follow buffalos. As a result, the seal and buffalo are their respective main sources of food, clothing, and shelter. Although both nomadic bands are skilled hunters, each group hunts for a completely separate animal, which is from where their many differences stem. To better understand the differences between the two, both tupiqs and tepees are further described and analyzed.

The Inuits spend their winters living in an igloo and their summers are spent

living in a tupiq, which is a tent made of seal skin. “The interior layout is similar to that of the igloo. At the entrance and at the edge of the bed two pairs of converging poles are erected. A little below the intersection two cross poles are firmly attached, forming a ridge; at the end additional poles are placed to form a tepee-like frame. Combined with the poles at the entrance, this frame forms the skeleton on which the sealskin cover is placed. It is tightly fitted and secured at the periphery with heavy stones. Overlapping sealskin doors prevent the wind from blowing into the tupiq” (Schoenauer 2000, 28).

The tepee of the Plains Indian is one of the best and most exemplary nomadic dwellings. The interior layout of the tepee consists of bedsteads, an altar, a hearth, and a place for wood. As described by Schoenauer,

The skeletal structure of the Plains Indian tepee was made by tying the top ends of the supporting poles (either three or four poles) together and standing them up; then additional poles, up to about twenty, were placed against the tripod or tetrapod. A tailored buffalo-hide cover was placed on the pole skeleton and was staked or weighted down with stones all around the bottom edge. A hole was left at the crossing of the poles to allow smoke from the interior fire to escape. All tepees were slightly tilted so that the smoke hole was off center toward the front side, thereby facilitating the closing of the hole in wet weather. The two flaps, or “ears,” of the smoke hole were each fastened to a separate pole enabling the adjustment of the aperture in accordance with the prevailing wind or to close it so that the tepee could be weathertight. The fire was built directly below the smoke hole, and the bedsteads were placed on the ground around the circumference except at the doorway, which habitually faced the rising sun.

To cover it required as many as twenty buffalo hides. Sometimes an additional hide lining covered the ground and ran up the tepee’s sides for 4 to 5 ft. This second layer of skin formed a closed bowl shape and prevented drafts from creeping in under the edges of the outer covering. The buffalo hides were more windproof than canvas. The air space between the outer and inner skin covers provided additional insulation in winter. In contrast, during the summer the bottom edge of the outer cover was raised to permit ventilation without draft. (Schoenauer 2000, 29-30)

Based on their ways of life and the types of shelter occupied, it is understood that the needs of both the Inuits and the Plains Indians are shelter, food, warmth, and comfort with religion also practiced by the Indians. Their nomadic practices and episodic dwellings offer a number of noteworthy characteristics that the proposed prototype should embody. Overall, tupiqs and tepees are effective shelters that are simple in design and thus, relatively easy to construct. It takes about an hour to erect the tepee

and less than an hour to take apart. The shape and form of the dwelling is basic, yet it offers maximum structural stability. When the Plains Indians are roaming, their dwelling materials are easily packed up and brought over to the new settlement with the use of a travois. It is of great benefit to be able to travel with the tepee materials because the builders then do not need to rely on the forthcoming environment (as the Bushmen and BaMbuti people do). The travois is made of the poles from the tepees, which thus have a dual purpose; this conserves space and limits the amount of materials carried.

The functionality and excellent weather accommodations provided by the buffalo hide and seal skin covers are noteworthy features that will also be considered. The role of the additional skin found on the tepee is rather simple, yet well thought out and quite effective in adapting to winter and summer weather. This method of developing a movable skin is definitely worth duplicating seeing that although Hawai'i generally has a cool tropical climate, there are moments of warmth and cold as well. As for the Inuits, their method of climate control is not as sophisticated as the Indians', however, it suits their lifestyle. By merely overlapping the skins, they prevent the wind from entering the interior and thus, keep the inhabitants warm. This simple gesture is appropriate for their needs because the tupiq was the Inuit's summer house, and thus, it is unnecessary to have a sophisticated weathertight shelter. Moving forward with this idea of skin covers, it is great that these animal hides are able to close off the interior from the exterior. Unlike the Bushmen and BaMbuti people, the Inuits and Indians had some level of privacy from their neighbors.

The interior of the tupiqs and tepees are more defined than those of ephemeral dwellings. Instead of having a large open space for various activities, the Inuits and Indians have features that occupy specific locations including a hearth, which as previously discussed is a great way to keep warm. Today, many people use blankets to keep warm, however, a blanket must constantly be carried whereas a fire can be constructed from onsite materials. Another feature that would benefit survivors is bedsteads. Beds are usually associated with feelings of comfort and relaxation, and thus, an immediate place to rest after one has been displaced would help alleviate a person's stress level. The last belonging analyzed is the altar, which was used by the Indians for religious purposes. While there are many religious people today, when a natural disaster strikes, it is unnecessary to include an altar in the emergency shelter.

2.13 Periodic or Regular Temporary Dwellings



Figure 14 (Left) A family outside of a yurt found in Mongolia. The retractable framework that creates a diamond design is covered by felt. (Right) The Bedouin black tent is a tensile structure that is constructed of woven goat hair fabric, ropes and poles.

“The portable tents of the pastoral nomads represent the third evolutionary stage of dwelling forms: temporary dwellings that are inhabited on a periodic or regular basis. Pastoral nomads have a hierarchical social organization consisting of migrating bands or other subgroups united by a tribal chieftain. Tribal societies represent a category of cultural development intermediate in complexity between hunting/food-gathering bands and agrarian folk societies” (Schoenauer 2000, 41). The two periodic dwellings studied are the Kirgiz yurt and Bedouin black tent. These portable tents are inspiring models to follow as they are strategically designed in order to cater to the climatic forces of their regions. Schoenauer offers an excellent description of both the Kirgizian yurt and Bedouin black tent.

The yurt is an ingenious and weatherproof dwelling that affords its occupants a remarkable degree of protection against inclement weather and, in particular, the strong steppe winds. The yurt has a circular plan with a diameter of 10 to 20 ft. Its walls are about 4 ft high and consist of lightweight willow latticework sections, called khana, that can easily be folded up like a children’s safety gate. In their expanded form, four to eight khanas and a door frame are lashed together to serve as a circular supporting wall of the roof. To the top of this wall are fastened the curved (if Kirgiz) or straight (if Mongol) roof poles radiating toward the center and fitted into a wooden ring about 4 ft in diameter. This compression ring at the top of the yurt also functions as the smoke hole. The forces that push outward are neutralized by a tension band tied around the top of the wall. Because of the yurt’s shape, wind pressure acting upon the structure results in anchoring it more firmly to the ground. At times, to increase the structure’s stability, a heavy stone is suspended on a rope from the central wooden ring.

Over the entire framework of the yurt, large pieces of heavy felt

(mundahs) are fastened, sometimes in two or even three layers, with air space in between in order to increase the comfort of the interior. A felt curtain, often ornamented, is hung over the door, which invariably faces south or southeast away from the direction of the prevailing wind. The door curtain as well as the wall panels can be rolled up to give good cross-ventilation if so desired. Curtains are also hung in the interior and can be let down to form separate compartments. Women always set up and dismantle the yurt.

The eastern half of the yurt's interior is the women's side; the western half, the men's and visitors' side. Storage boxes and bags as well as rolled-up bedding and carpets are placed along the walls.

A fire or argol (dried yak or camel dung cakes) is made in the center of yurt and is surrounded by dry stunted brush. The smoke escapes through the central hole in the roof; when necessary, the smoke hole can be closed by a piece of felt drawn across by a string so that even in severe weather the yurt offers its occupants adequate warmth. The overhead smoke hole acts as a time clock for the yurt's occupants; since the yurt always faces more or less the same direction, sunrays reaching through the hole into the yurt show the time of the day.

Although the framework is lightweight, the covering material is cumbersome and relatively heavy. However, the nomads' pack animals (camels, horses, and yaks) provide the means to transport not only the portable dwellings but also rugs and other household and personal belongings (Schoenauer 2000, 41).

The yurt is an exceptional flexible dwelling that caters well to the lifestyle of the steppes in Central Asia. While this type of shelter is a skin-on-rigid frame construction, the Bedouin black tent is a shelter that “uses tension as a means of support rather than a rigid structural frame” (Topham 2004, 10). Schoenauer has also described the architecture and use of a black tent.

*The typical Bedouin black-tent has a supporting structure of vertical poles, and its coarse black cover is made of woven goat's hair fabric reinforced by tension bands. The Bedouin call their tent *beit sha'r*, or “house of hair.”*

*The tent is always pitched by women. The first step entails the clearing of the site on level ground. Next the tent cover is spread on the ground. Then the ropes are pulled out and staked. Starting from one corner, poles are pushed up one by one. When the tent roof is aloft, the rear wall (*ruag*) as well as the dividing curtain (*qata*) are pinned in place. The whole operation is usually completed within an hour.*

Being a tensile structure, the typical black-tent uses very little wood for its supporting frame. In contrast to the skeleton of the yurt, which is stable without its cover, the black-tent's frame is unstable without the stayed tensile cover. Its

poles are mere compression members supporting the weight of the tent cover and its stays. (The tent's long rope stays are only allowed to cross another tent's stays if their respective households are related in some way.)

The roof line of the black-tent is very flat to minimize resistance to winds and sandstorms. The front of the tent is oriented either toward Mecca or toward the south if protection from the northern winds is desirable. The women's side of the tent, often bigger in area than the men's side, is the living and working area of the whole family; the men's side covered with carpets, is the reception area. The contents of the tent are scanty, consisting mainly of cooking utensils, pack saddles, water skins, wheat bags, halters, bowls, and various weapons. A stranger must always approach a Bedouin tent from the front.

The average length of the Bedouin tent ranges from 20 to 30 ft; the depth is rarely more than 10 ft; and the height goes from 5 to 7 ft. A sheikh's tent, however, may attain a length of 70 ft.

The black-tent is indigenous to the area between the 30° and 35° north parallels. Basically, it provides shade in an area marked by clear skies and intense solar radiation. Using very little wood for its structure, the black-tent is an admirable adaptation to regions where wood is a scarce commodity. But this dwelling is less than ideal in areas with considerable precipitation because its cover is not completely waterproof. Indeed, when waterlogged, it is both heavy and cumbersome to move (Schoenauer 2000, 45-46).

The description provided by Schoenauer supports the idea that the needs of the Kirgizians include shelter, food, protection from the elements, warmth, comfort, privacy, and storage. The Bedouin people's needs are quite similar with shelter, food, protection from the elements, privacy, safety, and storage comprising their list of needs. These requirements are fulfilled through the unique design qualities that both bands have invented. Some of these design qualities should be replicated in the proposed prototype; however, there are a few design traits that are not necessary in an immediate response to a natural disaster.

While the yurt and black tent are impressive dwellings that function similarly to an urban house, there are qualities that are not applicable to disaster victims. For instance, both the Kirgizians and Bedouins use curtains to provide privacy and to divide their homes into specific areas for activities such as sleeping, cooking, and entertaining. In times of a disaster, the use of a curtain to provide families and individuals with privacy is great; however, it is superfluous to create interior divisions for sleeping and cooking. Instead, it is believed that an open floor plan that offers adequate space for an individual to sleep and reside in will be appropriate. Additionally, while the size of both the yurt and black tent are fitting for the needs of their users, they are too large for the proposed

prototype. Of greater concern is the weight of the materials associated with such large dwellings. Unlike the Kirgizians and Bedouins who are able to rely on their pack animals for transporting their shelter materials to the next site, the proposed prototype is meant to be worn to the next site. Thus, the proposed prototype should be lightweight.

Aside from these few irrelevant features are a number of remarkable qualities including portability, structural attributes, and the ability to withstand a hostile environment. It is argued that these portable shelters are constructed with low-tech materials that are simple yet function in a sophisticated manner. Starting with their simplicity, the yurt and black tent take about an hour to erect and dismantle. While both are quick and easy to assemble, the shelters perform at an incredible level. It is due to the architectural responses to the climatic forces of the steppes and desert that these dwellings are deemed sophisticated. The Kirgizians have developed a type of flexible panel system, similar to the Plains Indians, that allows their household to endure the harsh winters and warm summers of the steppes. As for the Bedouins of the desert, they have established a shelter that is basically a sunshade that protects their inhabitants from the sun while providing ventilation throughout the dwelling. This idea of having a straightforward and portable shelter that is comfortable (seeing as it meets the demands of its surrounding environment) is an important feature that demonstrates what the proposed prototype should embody.

Compared to the inhabitants of the ephemeral and episodic dwellings, the Kirgizian and Bedouin people take privacy and safety into consideration. As previously discussed, privacy is achieved through the use of a curtain. For these particular bands, curtains were used to attain privacy between the spaces of men and women; however, disaster victims will not utilize curtains with this same intent. Instead, this method will be practiced in order to achieve a sense of retreat for families and individuals. Safety is also of concern to black tent dwellers. In addition to carrying weapons, these people are very cautious of strangers approaching their shelters from any direction other than the front. At this point, it is unknown how the safety and welfare of disaster victims will be addressed, however, it will definitely be considered.

2.14 Seasonal Dwellings



Figure 15 (Left) A boma used by the Masai people in the plains of Kenya and Tanzania. (Right) The Navaho hogan, a low-tech hut that is found in the southwestern United States.

“The dwellings of the seminomads – the fourth category [of the] classification system – ...are occupied seasonally or for several months at a time. Seminomads practice some form of cultivation (that is, they plant and harvest crops) between seasonal migrations in their quest for survival as hunters and stock breeders. Their social organization is that of a tribal community, composed generally of a number of clans bound by strong social ties. This type of social structure is found predominantly in the continental steppe and the subtropical savannah regions” (Schoenauer 2000, 48). The two seasonal dwellings studied are the Masai boma and Navaho hogan, neither of which offer design ideas or are relevant to the proposed prototype. These dwellings are permanent, take about a week to construct, and are made of onsite gathered materials. For this reason, research will focus on the survival needs that they meet and their architectural features will be overlooked.

Masai families reside in a hut made of posts, saplings, twigs, leaves, grass, cow dung, and mud. Schoenauer explains that

[the huts] are so low that one cannot stand upright inside them. The interior, lit only through a narrow door opening, is divided into two specific use areas. Immediately inside the hut is usually a privacy wall and an enclosure for young animals, which occupies about a third of the total area. Beyond this enclosure is the living quarter with its central hearth. Flanking the hearth are two beds, one for the older children and a second one for the mother. The children’s bed is used for sitting during the daytime; the woman’s bed is considered private and therefore screened off and not used during the day.

At night the cattle are driven into the central space of the kraal for protection against wild animals. When the dry season forces the Masai to move in search of new waterholes and better grazing grounds (or if someone dies

inside a bomaboma) the kraal is abandoned (Schoenauer 2000, 54).

From this set of information, it is obvious that the needs of Masai families are shelter, food, water, warmth, privacy, safety, and comfort. This shelter distinguishes itself from the other dwellings studied as it is a low-tech permanent shelter that is occupied for the majority of the year. Their lifestyle and needs are not dependent on modern day conveniences; however, they are centered around the use of a non-transient dwelling. For this reason, the ways in which their necessities are achieved are not worth duplicating.

The hogan of the Navaho people is another permanent dwelling that does not offer inspiring design ideas for the prototype. However, research on the hogan is informative in terms of revealing the needs of the Navaho people. Below is a description by Schoenauer.

The traditional, and more substantial, dwelling of the Navaho – the Hogan – is a low, one-room, mud-covered log hut with a doorway facing the east... Only one family occupies a dwelling, [while others are used for storage].

There are several types of hogans. The older, circular type consists of three forked poles locked together at the top with other poles leaning on them; the whole structure is then covered with earth. The later and more usual type has a circular plan with four upright forked poles supporting a log deck and sloping walls, all covered with tamped earth. These dome-shaped huts do not have windows; the smoke of the open fire escapes through the smoke hole in the roof. A blanket is often used for a door.

Indeed, the Hogan is very comfortable both during the day and at night, since the diurnal extremes of temperature of the region are evened out by the lag in heat gain and heat loss of the thick layer of mud covering. Thus, a Hogan is cooler than the outdoors in daytime, and warmer at night.(Schoenauer 2000, 50-51)

Based on the research gathered, the needs of the Navaho people include shelter, food, protection from the elements, and comfort. Similar to the boma, the hogan is made of onsite gathered materials that are constructed into a permanent dwelling. Remarkably, this low-tech shelter is accommodating in the weather conditions of the southwest, however their method of using mud to control the hogan's temperature is useless to the proposed prototype. As for the other indigenous architectural traits, they are not applicable or appropriate to the design of the prototype.

2.15 Semi-Permanent Dwellings



Figure 16 (Left) Mesakin Quisar Cluster dwellings

The fifth stage of the evolutionary hierarchy of dwelling types includes the semipermanent huts and houses of a sedentary society. This type of society, which has a predominant social organization known as a folk community, subsists mainly by the cultivation of staple crops. Its members are commonly referred to as hoe peasants, for although they may use a rudimentary plow, they have not yet reached the advanced stage of agriculture in which more sophisticated plows and other farm implements are used. These primitive cultivators have to leave their lands fallow for a few years after their crop yield decreases, except where they have irrigated the land. This, of course, has a direct effect on their housing patterns. In accordance with their cultivation system, the use period of the hoe peasants' semipermanent dwellings varies from a few to about fifteen years. (Schoenauer 2000, 57)

The semipermanent dwelling studied is the Mesakin Quisar cluster dwelling located in the Sudan. Compared to the other indigenous shelters, the Mesakin Quisar have designed the most developed and skillful dwelling. "A typical Mesakin dwelling consists of five or six windowless round huts constructed on stone foundations around a courtyard. The base is carefully prepared to allow rain water from the inner courtyard to drain off easily" (Schoenauer 2000, 60). It functions very similarly to a typical house as it has rooms and spaces for separate functions, walls that are from 7 to 10 ft high and a conical grass roof. These huts are permanent structures with the huts and walls made of adobe and mud, and the roof made of woven grass and boughs. Schoenauer describes the layout of the Mesakin Quisar cluster dwelling and notes that

Each hut is reserved for a particular household activity. For example, one hut is the main sleeping hut, one is an animal pen for chickens, goats, or pigs, and several are storehouses. The animal shelter often contains a loft that is reached

by a separate entrance on a higher level and is used as a sleeping platform for the young boys of the family; older girls sleep in the hut where the corn is ground. Between two turrets of a cluster dwelling an elementary shower is constructed from a calabash cradled on a pair of antelope horns; the bather has to reach up to tilt the water-filled container forward so water can trickle from a hole near the rim of the vessel.

The courtyard of the round-hut cluster is the principal space of the Mesakin dwelling. It is where the most social activities, eating, and cooking take place. A hearth consisting of three rounded stones to support cooking vessels is found in the center of the courtyard, and other stones to sit on as well as simple chairs made from branches are scattered around the hearth. The exterior walls of the cylindrical huts defining the courtyard are equipped with pegs on which weapons, tools, calabashes, and a variety of pots hang. (Schoenauer 2000, 60-61)

This explanation indicates that the needs of the Mesakin Quisar are shelter, food, protection from the elements, privacy, comfort, hygienic procedures, and storage. The design of the Mesakin hut is somewhat advanced, and in regards to the proposed prototype, there are some features that are irrelevant while others inform potential qualities and ideas for the kit. Beginning with the least inspiring ideas, the hut is not portable and the materials are too primitive. In addition, ventilation and lighting throughout the dwelling are limited as there are no windows. Within each hut, the only opportunity for air to circulate and light to enter is through the entrance. In certain huts, the entrance is a hole “measuring between 12 and 14 inches in diameter and placed as high as 5 ft above the ground” (Schoenauer 2000, 61). For the Mesakin people, it is beneficial and functional to place the opening at that location as it “ensures a more desirable indoor climate..., is difficult for snakes and scorpions to enter the hut over the high threshold wall..., and when huts are used as granaries, it is easy to seal off the entrance” (Schoenauer 2000, 61). However, today it would prove impractical and be a nuisance to a disaster victim.

Among the more commendable and prospective architectural features are design inventions not explored by the other indigenous people studied (or possibly that the information gathered did not reveal). For instance, it is ingenious to erect a number of huts in order to fulfill specific functions; however, it is unnecessary for the prototype to create a number of different spaces. Instead, a large open space that has the ability to connect to other units will be sufficient. Another interesting element is the shower. Seeing that this is the first household to incorporate a shower, it raises the question of

how other tribes dealt with hygienic issues and if they were important to them. A third noteworthy quality is the water drainage system. To protect the Mesakin people from rain, “the base is carefully prepared to allow rain water from the inner courtyard to drain off easily” (Schoenauer 2000, 60). It is a simple gesture to a mild problem and even though that particular method may not be followed, it is a reminder of certain qualities that can be incorporated.

2.16 Indigenous Shelters Conclusion

The information obtained regarding the various indigenous dwellings of the world has brought about helpful material that will be of aid when designing the proposed prototype. Based on the research collected, discussion will focus on three topics: the needs of these people; their inventive methods of survival, which allow them to live off of low-tech technologies; and finally, the few questions left unanswered even after these discussions of how individuals survive in the wild.

Interestingly, this study reveals that the needs of each household are dependent on the settlement’s available resources and climate. These two factors determine the architectural style of each household, and because each group lives in a different location, it explains why each band has different needs. Furthermore, it explains why certain bands are more concerned with particular necessities than others. For these reasons, it is difficult to conclude the hierarchy of survival needs. Although the needs of each indigenous group vary, there are common survival necessities that are found among each group. The technique used to determine their needs was not based on a specific equation or method. Instead it was based on their cultural practices, material possessions, and the interior layout and architectural features of each dwelling. To better organize the data, a chart that reflects the needs of each indigenous people has been organized, see Figure 17. This chart itemizes the basic life sustaining necessities, and then matches them to the appropriate band. In addition, it lists some of the material possessions that each band owns. Included in the list of survival needs are shelter, food, water, warmth, comfort, protection from the elements, privacy, storage, safety, and hygienic procedures. This chart does not suggest the order of importance for each necessity; instead, it acts as a future design tool.

In addition to understanding the needs of people, their way of life was also studied. In general, this study revealed many surprising ideas that are impractical to apply to the proposed prototype. Nonetheless, there are still some noteworthy features

that are worth duplicating. In most cases, the idea behind cultural practice is meant to be copied, and not the original construction. Below is a list of recommended traits from indigenous shelters that can be considered in the prototype construction, and a short description that shows why it is beneficial. In parenthesis is the group that practices these qualities. For further information the previous sections should be referred to.

- **Hearth** (Bushmen, BaMbuti, Plains Indians, Kirgizian, and Masai) A fire is not only used by the indigenous tribes, but by the urban person as well. It is a great way to control the climate when your shelter is unable to.
- **Expansion** (BaMbuti and Mesakin Quisar). This is a great characteristic because when the shelter gets too small, it can continue to grow and thus, accommodate large groups.
- **Sharing** (Bushmen). In the event of a disaster, the act of sharing and giving are measures that help the recovery process run more smoothly. Of course, it isn't the best solution to rely on others for help nor is it always possible to give to others, however when possible it should be practiced.
- **Simple** (Plains Indians, Inuits, Kirgizian, and Bedouin). With a fairly straightforward design, the construction of a shelter becomes relatively easy to construct. It takes about an hour to pitch the shelter and less than an hour to take apart. The shape and form of the dwelling is basic, yet it offers maximum structural stability.
- **Portable** (Inuits, Plains Indians, Kirgiz, and Bedouin). The material of their dwellings is easily packed and brought over to a new settlement with the use of either a travois or animal. It is of great benefit to be able to travel with the materials because the groups do not need to rely on the forthcoming environment.
- **Movable skin** (Plains Indians, Kirgizian, and Bedouin). The role of additional skin is rather simple, yet well thought out and quite effective in adapting to the winter and summer weather. This method of developing a movable skin is definitely worth duplicating because even though Hawaii generally has a tropical climate, there are changes in temperature as well.
- **Privacy** (Kirgizian and Bedouin). Curtains were used to attain privacy between the spaces of men and women; however disaster victims will not utilize curtains with this same intent. Instead, this method will be practiced in order to achieve a

sense of retreat for families and individuals.

- Safety (Bedouin). In addition to carrying weapons, the Bedouins were very cautious of strangers approaching a shelter other than from the front. A sense of safety should be provided as this will allow survivors to concentrate on other important issues.
- Site Specific (All). Inhabitants have designed and organized tents to cater to specific environmental conditions. It is crucial to take the location and natural surroundings into consideration when designing as this will enable an appropriate prototype.
- Multi-functional (Plains Indians and Kirgizian). The ability to incorporate multiple uses for one object is an essential quality that the prototype should embody. This helps to conserve space and limit the amount of materials being carried.
- Comfort (BaMbuti, Inuit, Plains Indians, Kirgizian, Masai, Navaho, Mesakin Quisar and Homeless Shelter). It is important to feel at ease while wearing and/or inhabiting the prototype. In addition, it is advantageous to possess a comfort object for reason that it is uplifting and can increase a victim's mental and emotional well-being.

INDIGENOUS SHELTERS

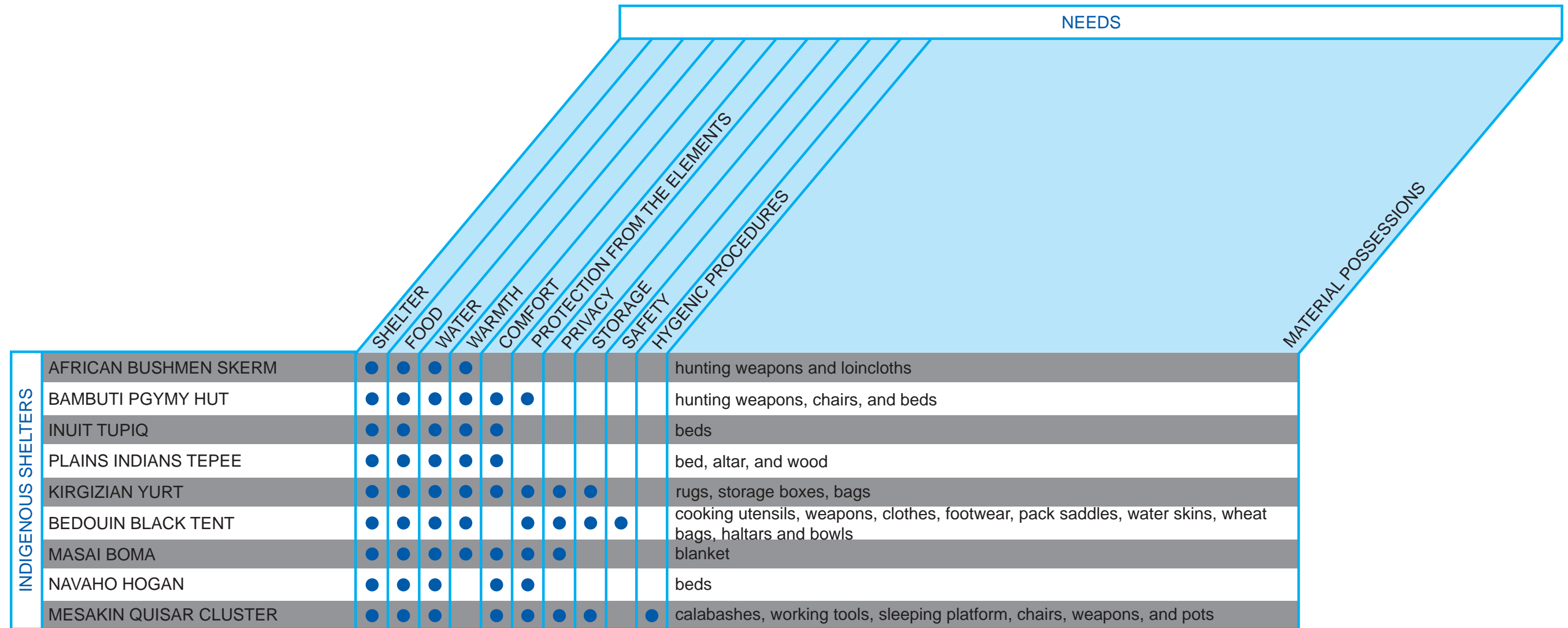

Figure 17 Indigenous Shelters Matrix

2.2 Low-income Housing

A study of low-income housing is significant to this thesis because such buildings “satisfy the basic minimal requirements for healthy living ... [and] provide a primitive level of comfort compared with larger apartments” (Teige 2002, 234). Low-income houses are permanent buildings that clearly cannot be worn, so in terms of the wearable factor, they are inapplicable. However, the spaces utilized by low-income residents are key in understanding survival at subsistence levels.

Low-income housing is typically a very small and tight unit that is about 800 square feet. It is a private and intimate space that can comfortably provide for a family of four. As described by Karel Teige, “the specifications of the dwelling minimum must not be reduced below biologically acceptable limits. In other words, inhabitants must be provided with sufficient sun, light, and air, as well as adequate space to work, rest, sleep, eat, and bathe” (Teige 2002, 248). Following this principle, a typical unit will include spaces/rooms for a kitchen, living room, bathroom, and bedroom. From these spaces/rooms, one can deduce that minimal requirements for survival and healthy living include, but are not limited to, food, water (which are found in the kitchen), clothes and a place to sleep (which are found in the bedroom), a lavatory and shower (which are found in the bathroom).

In a sense, a house is storage for the facilities listed above and other personal belongings, a majority of which are arguably not critical life survival items. This raises the question of how big of a space someone really needs to survive, especially since “people today spend most of their time outside the home, returning there by and large only to sleep” (Teige 2002,241). It seems that because people have a safe place to store their belongings, they utilize that option as compared to someone who does not have a place to store their belongings. For instance, a studio is a small room/space that includes a living space, kitchen, and bathroom like that of an apartment. Studios can be as small as 500 square feet, and due to space limitations, inhabitants are forced to choose their furniture and belongings wisely as nonessential pieces tend to be an obstruction. Nonetheless, regardless of their size and storage capabilities, studios still fulfill their functions and provide people with the basic necessities of life.

Subsequently, this idea of creating a minimal space that provides individuals with critical survival supplies will be further developed in the proposed prototype. Although the minimum size of a house has been questioned and although it has been argued that a house stores many unimportant items that are unnecessary for survival, the reality is

that the design of a house has a number of specifications that are necessary for comfort, health, and protection. There is an understanding that permanent buildings have codes that need to be followed, which explains why they can only be so small. The proposed prototype will further explore the possibilities of minimal spaces that are portable and do not have to follow building codes.. So while it functions like a home, it does not look like a permanent home.

2.3 Homeless Dwellers

Homeless dwellers live unique lifestyles that require innovative methods for survival in the urban environment. As persons who are without a house, they are quite resourceful in their survival strategies, and it is due to this that their way of life becomes of great use for the proposed prototype. Jill Leufgen and David A. Snow discuss the survival strategies of a homeless person and suggest that

All people must negotiate ways to satisfy basic human needs, and homeless people are no exception. However, the homeless routinely face serious challenges to survival that housed people generally do not confront or at least not with the same degree of urgency. Such challenges include securing food and shelter on a consistent basis, establishing reliable social relationships, and even finding a measure of meaning and sense of self-respect. The resources and support requisite for attending to such basic human needs are generally taken for granted by most domiciled citizens; homeless people must scramble daily to meet these needs. Doing so entails the employment of a variety of survival strategies that address material, social or relational, and psychological needs.
(Levinson and Ross 2007, 143)

As described, surviving homelessness is a challenge. It is a daily battle with many obstacles that are not always overcome. People who face similar situations are the destitute or displaced survivors of natural disasters. These people too, are faced with challenges that range from, but are not limited to, “the [appropriation] of objects to the construction of a shelter to a location of personal space, all on a portable basis” (Kronenburg 1998, 39). For this reason, it is crucial to analyze the way of life of homeless dwellers in an investigation of the basic necessities of life and how they can be achieved.

Based on observation and research, four categories of homelessness have been

created:

- Homeless Shelter Dwellers: people who take advantage of temporary residences that offer recovery programs and services as well as shared living spaces
- Tent Dwellers: illegal campers who live in tents on beaches, sidewalks, and in parks
- Street Dwellers: persons that reside in makeshift shelters made “of plastic sheeting, cloth, or cardboard, sometimes clustering together on the pavement or empty private or public space” (Levinson and Ross 2007, 378)
- Cart Dwellers: homeless persons that use a shopping cart to store and travel with their belongings

Research has been concentrated on the homeless people in Hawai'i for the sole reason that the proposed prototype will be designed and developed for the people of Hawai'i. Focusing on these residents will reveal the needs and problems that these local people face.

2.31 Homeless Shelters



Figure 18 (Left) Interior view of the Next Step Homeless Shelter in Kaka'ako showing the cubicles in which transitional homeless shelter residents live. (Right) Homeless residents begin to settle in their cubicles and organize their belongings.

Homeless shelters are described as shared living spaces that can be difficult for homeless residents to live in for reasons that these dwellers are unable to “find time to

themselves and keep many aspects of their life private” (Williams 2003, 57). These shelters attract all types of people and based on the research gathered, there are two types of homeless shelters: transitional homeless shelters and emergency shelters. Susan M. Barrow cites that “for the U.S. Department of Housing and Urban Development (HUD), ‘transitional housing’ designates programs intended to facilitate the movement to permanent housing of homeless individuals with mental or physical disabilities and homeless families with children, usually within twenty-four months” (Levinson and Ross 2007, 305). Emergency shelters are facilities that provide homeless individuals with programs and services in the day and a place to sleep at night. While the similarities between these two types are many, there are a few differences including the rules and regulations of the facilities. Generally, the rules established by the shelter tend to attract their users. For instance, those seeking refuge at transitional shelters are people who strive to maintain basic survival needs whereas the majority of those who take cover at emergency shelters are substance abusers who choose their homeless lifestyle. In order to better understand the differences between transitional shelters and emergency shelters, both topics have been further analyzed. The discussion begins by noting the similarities among the two institutional spaces. This topic is followed by an examination of the lifestyle of transitional homeless shelter dwellers and lastly, the lifestyle of emergency shelter users .

Although it has been found that the design and policies of transitional and emergency shelters vary, each institutional space offers roughly the same services and programs. For instance, an individual who takes advantage of a shelter can obtain:

- meals one to three times a day
- a storage space varying in size from a small locker to a 12 by 6 foot cubicle
- hygienic facilities for using the lavatory, taking a shower, and tooth-brushing
- a safe haven with a roof
- e-mail access to communicate with others
- laundromat services to wash clothes

In addition to these benefits, there are programs that help homeless people onto the road to recovery, such as health services and substance abuse, employment, and permanent housing assistance programs. So while shelters may have strict rules and staff practices that do not appeal to the homeless, they offer a number of basic life

necessities that are free.

The rules established at transitional shelters are “basic regulations that serve as surveillance and control mechanisms” (Williams 2003, 59). Some of the rules at these shelters include curfew, mandatory meetings with caseworkers, respecting others, smoking only in designated areas, and not being in possession of weapons, alcohol, drugs, or pets. Many homeless people believe these rules are strict, and as a result, these institutions appeal to individuals who are trying to end their homelessness and start more stable lives. These people include the working class, single mothers, and individuals who cannot afford to pay rent, to name a few.

The hours of operation for transitional homeless shelters range with some that serve as 24-hour facilities and others that are closed during the day and only open at night. Shelters that are closed during the day force people to find refuge elsewhere and anywhere. As a result, the amenities that the shelter provides become inaccessible, and in the meantime, people must attain these amenities through other resources. For some of these people, it is not a problem as they have jobs and therefore have access to some amenities at their job. Homeless workers are fortunate enough to keep busy during the shelter’s closed hours, earn money for food and other necessities, and have access to a restroom at work. Shelters that are always open allow residents to stay in their designated spaces and also the advantage of using the amenities of the shelter all day. In this situation, homeless residents are technically not homeless since the transitional shelter provides them with the spaces and functions of a house, such as a sleeping quarters, bathrooms, and food. Depending on the shelter type and a person’s gender, the size of an individual’s designated space will vary, however, regardless of its dimensions and its spatial capabilities to store personal belongings, there are common objects that all residents possess. These include blankets for comfort and warmth, a cot or bed to sleep on, a television or radio for entertainment, and luggage, a plastic container, drawer, or laundry basket for storage space. These common items carried by homeless people demonstrate their needs and how they address them.

The rules established at emergency shelters vary, however, for the purposes of this research, the focus is on emergency shelters that do not have strict rules and invasive staff practices. Attention is given to shelters that provide homeless people with support programs and services in the daytime and a place to sleep at night. These facilities and programs for homeless people are voluntary, which explain why drug and alcohol abusers are attracted to these types of shelters. These homeless people can

roam the streets with hopes of acquiring illicit substances in the daytime and return to a shelter at night, intoxicated and ready to sleep. Compared to homeless people who have intentions of ending their destitute lifestyles, these people have no ambitions of getting healthier.

It is argued that chronic drug and alcohol abusers are simple people who have very few necessities. Unlike others, these homeless people overlook the necessary materials and needs for survival. According to a man named Ken who used to be a homeless alcoholic, the most important thing to a homeless person who is a heavy substance abuser is to get money to buy alcohol or drugs. Second to this are more obvious life essentials. It seems that this thought process stems from the known fact that there are many programs and services that provide homeless people with the necessities of life. Thus, homeless people focus more on items that cannot be readily picked up at shelters rather than items that can be picked up. At shelters, homeless people can find food, a locker to store their belongings, a mat and a blanket for bedtime, a washer and dryer to wash clothes, and a bathroom to shower, brush teeth, and perform other hygienic procedures.

One rule Ken recalled was that in order to sleep at the shelter and receive a mat and blanket, individuals must arrive before 10:00 p.m. If not, individuals were denied admission and would have to sleep outside. In this situation, Ken had one request, which was to sleep on soft grass. He didn't need a blanket or anything else to keep him warm because typically the weather in Hawai'i is warm and does not fluctuate too much. He also didn't need a pillow, but because he had a backpack on hand that he could use as a pillow. In his backpack was an extra change of clothes and a long sleeve shirt for cold nights. Ken said rainy days did not concern him because an easy solution to this minor problem was to ride the bus for several hours. Although this may seem like a waste of time, it is not as alcoholic homeless people do not have a daily agenda and therefore have no sense of wasting time. For entertainment, some homeless abusers spend time at the library because it is accessible, safe, and comfortable. In addition, according to Jeffrey L. Salter and Charles A. Salter,

...public libraries offer such facilities and oppositions as these:

- *Open Access. Generally, the homeless cannot be turned away no matter their reason for being there, so long as they don't grossly violate the rules. They typically don't need an ID to get in and can use many of the library's services with anonymity. Many libraries are open during evening hours and*

on weekends.

- *Comfort.* Unlike the harder, plastic chairs available at some institutions, which are designed to speed people on their way, the library typically offers comfortable chairs that encourage long-term use.
- *Sanitation.* Clean restrooms are available not only for bodily functions but also for improvised bathing or washing, shaving, and brushing teeth.
- *Communication.* With ready access to the Internet via computer and a free e-mail address (available from services such as Hotmail or Yahoo), one can easily surf the Internet or send and receive e-mail. This can provide an erstwhile “residence” for a homeless person.
- *Companionship.* Homeless “regulars” at the same library may well strike up friendships or form a sort of para-community of acquaintances; some even “network” information about shelters, meals, etc.
- *Entertainment.* A library patron can pass the time all day with newspapers, magazines, books, audios, etc.

Best of all, from the point of view of homeless people, is that all these services are free. (Levinson and Ross 2007, 315)

Analysis of homeless people who utilize transitional shelters and emergency shelters show that although they are destitute individuals who are in an unfortunate situation, they make the most of what shelters have to offer, and from these places, they are able to acquire the essentials of life. In addition, it shows the needs of displaced people and the methods used to obtain their needs. The lifestyles and interests of homeless shelter clients vary; however, their life survival needs are similar. Unlike survivors of natural disasters, homeless people are able to rely heavily on permanent buildings, such as shelters and libraries. Depending on the type of shelter, their needs can be addressed immediately and without delay. So while one may assume that a homeless person experiences the same events as a displaced disaster survivor, this is not completely true. In times of a natural disaster, history has proven that individuals cannot rely on buildings for their needs. For this reason, a homeless person's strong reliance on shelters and other permanent facilities become somewhat irrelevant to this thesis while the analysis revealing the needs of homeless people is extremely significant to the proposed prototype.

2.32 Tent Dwellers



Figure 19 Illegal campers occupy the beaches along Farrington Highway on O’ahu’s west coast. (Right) Homeless dwellers at Depots Beach in Nanakuli take refuge in tents.

“Although most cities and communities provide some facilities and support for the homeless, particularly shelter, food, and clothing, not all homeless people utilize these support structures. Some do so on a regular basis, of course, but many use these services only intermittently, and some hardly at all” (Levinson and Ross 2007, 144). In Hawai’i, the homeless who are among this category are tent dwellers or illegal campers who can be found camping in parks and on the beach.

Similar to those who are in transitional shelters, many of these people have regular jobs, but struggle to keep up with the high cost of living. Many illegal campers prefer camping rather than taking refuge at transitional shelters because they have more freedom and privacy. It is a compromise to take refuge in tents rather than shelters, however, many people do it and seek out the amenities provided by homeless shelters through other means. One feature shared by shelters, parks, and beaches is hygienic facilities for taking showers, brushing teeth, using the lavatory, shaving, and handwashing clothes. As for obtaining other basic essentials, the methods practiced are different.

Based on interviews with tent dwellers along the west coast of O’ahu, there are a number of ways to fulfill the essentials of life. Starting with shelter, homeless people rely on tents that are staked to the ground. These tents serve as the primary protection from weather, which includes rain, wind, and sun. According to one homeless woman, to better stabilize her tent, she strategically places certain items inside, including a folding mattress, baby crib, and containers. This method becomes of great use when the winds are high. For extra protection from the sun and rain, a tarp that is either supported by

steel poles or ropes is layered over the tent. This feature has multiple functions. For instance, in addition to holding down the tarp, the ropes are used as a laundry line to hang dry clothes. Also, since the tarp is larger than the footprint of the tent, it creates a vestibule or covered outdoor space where many put chairs. Unfortunately, the tents and tarp do not block out cold air, so to address cold weather and keep warm, people use blankets or jackets.

Another issue is food. The homeless are fed through the food supplied by local food banks or purchases at nearby grocery stores. The food gathered includes both dry and cold goods. To keep refrigerated items cold, coolers with ice are used. To cook these items, stoves powered by propane or barbecue grills are used.

According to the illegal campers interviewed, safety and protection from harm are not among their worries. Similar to homeowners who look out for their neighbors, the homeless people who live in tents along the beach or in parks have their own community where everyone is acquainted with their neighbors and takes interest in protecting their belongings. So while they are aware that their belongings can get stolen, they are also certain that their neighbors are keeping an eye on their things.

Generally, tent dwellers take refuge at the same location for months or sometimes even years, and as a result, personal belongings accumulate. The containers used to store belongings vary in size, however, 30-gallon plastic bins are commonly used. While some tents are filled with clutter and unnecessary objects, such as animals and chairs for people to sit down and gather, others are very tidy with only the most important necessities such as clothes, food, utensils, blankets, and medicine. It seems that the unnecessary objects serve as a form of entertainment and companionship – things that help the homeless cope with their situations.

The issues faced by illegal campers are many, and at times, their lives can be very challenging and repetitive. Compared to the people who take refuge at shelters, homeless tent dwellers are less fortunate as they do not entirely rely on the services provided by permanent buildings. For this reason, these illegal campers relate somewhat to natural disaster survivors. Of the main permanent buildings and free services that they rely on are the food pantries at churches and the bathrooms at parks and beaches. Other than that, homeless people achieve the basic necessities of life through their own means and with the money they earn from work. With food and hygienic facilities being the only free services, illegal campers must still achieve a sturdy shelter that will protect their families and belongings from sun, rain, wind, and other

unpredictable weather situations; a mattress or bed to sleep on; blankets and clothes to keep warm at night; and equipment to prepare and cook their food, to name a few. These issues are shared by victims of natural disasters before the government steps in. A few of the solutions practiced by tent dwellers can be considered in the proposed design, such as the use of a tent and an extra layer for added protection. As for the remaining practices, they reveal an individual's basic survival needs and some of the features that the prototype should have.

2.33 Street Dwellers



Figure 20 (Left) Make-shift homeless shelter made of cardboard and cotton sheets. (Right) Homeless individuals sleeping on the sidewalk with only their backpack.

Street dwellers are chronic homeless persons that reside, loiter, and slumber on the streets and sidewalks. These people “generally have no protection...; and at most they might improvise shelters of plastic sheeting, cloth, or cardboard, sometimes clustering together on the pavement or empty private or public space close by” (Levinson and Ross 2007, 378). These families and individuals “are prone to the abuses of strangers passing through, subject to the harsh weather conditions, have no sense of privacy, security and dignity. Some need medical attention and most, if not all, need livelihood to support their families” (Pareja 2010).

The shelters of these homeless people vary from some who have no shelter to others who have makeshift shelters made of low-tech materials. A homeless father who was interviewed explained the obstacles that led him to end up in a makeshift shelter along a sidewalk in Kaka’ako. He began by sharing that he had exhausted all his shelter resources and had nowhere else to go besides the streets. He mentioned that once a family is evicted from low-income housing, they are unable to return, and he also shared

how he had reached the two-year maximum at a transitional shelter. In addition, he overstayed his welcome at a family's home, and as a result of these events along with the struggles of being unable to hold a regular job, his family wound up on the streets. To protect his family, he set up a temporary shelter that consists of a sheet roof, along with a piece of cardboard, a shopping cart, and a wheelchair that make up the walls. They are unable to permanently establish an improvised shelter along the pavement as it is unlawful. As a result, they are constantly on the move with their weekdays spent in the park and their weekends spent in their improvised open shelter along the sidewalk.

Street dwellers are constantly on the move, and consequently, carry very little with them; mobile objects are crucial. As described above, the father possesses a shopping cart and wheelchair. With these two items, he can quickly disassemble and pack up their shelter within a few minutes. He explained that inside their shelter was nothing but a blanket to lay on, which made the packing process quite easy. Among the things he travels with and considers important are food, clothes, and the materials for his shelter.

Similar to tent dwellers, safety and protection from harm are not among the worries of street dwellers because homeless people have their own community and a peer understanding of the importance of protecting the belongings of their neighbors. In addition, these homeless people do not worry about the availability of a restroom as nearby parks have bathrooms. An unexpected concern for many families was having their children taken away by Child Protective Services, which in the case of a natural disaster would not be a problem for parents.

In addition to street dwellers that use improvised shelters, there are those who use no shelter and basically sleep anywhere and many times without anything. These people tend to stay in spaces that are warm, which include the inner corners of building fronts and alleyways. At most, these people have a sleeping bag, blanket, or backpack. It is assumed that these people are able to roam the streets because they rely on the services and amenities of a shelter, from which they are able to acquire the basic necessities of life.

2.34 Cart Dwellers



Figure 21 (Left) Cart dwellers taking refuge in the inner corners of building fronts. (Right) Homeless persons loitering in downtown Honolulu with their shopping carts filled with bulky and numerous bags.

Homeless persons that use shopping carts to store and travel with their belongings are more commonly known as cart dwellers. These people are often assumed to be mentally ill, however, the validity of this argument has never been proven and seems to stem from observations rather than statistics and test results. Regardless of the mental state of cart dwellers, aspects of their survival techniques are informative and helpful for the design of the proposed prototype. In this category, the focus is not on the needs of these homeless persons, but instead their use of the shopping cart.

Christopher M. King suggests that “this acquired vehicle allows individual[s] the qualities of a room within an urban climate without the permanence of occupying a ‘real site.’ The cart becomes the boundaries of this individual’s space, or...the container of his/her objects. Personal space in this case is constituted solely by the storing, use, and daily routine of each item that accompanies this person on his or her daily meandering” (Kronenburg 1998, 39). It is argued that a large amount of the objects carried in the carts are worthless. The majority of the items held are kept in plastic or garbage bags to conceal them from rainy weather.

The use of a cart is convenient as it suits the needs of homeless people. Its useful qualities include wheels for easy traveling, a reasonable amount of space for storing objects, and easy handling for stress prevention on a person’s body. While these are all beneficial qualities that can be of use when designing the proposed prototype, there are constraints that should be modified. These constraints include a lack of privacy, protection from the elements, and a brake and lock system. Overall, the benefit of being a cart dweller is the ability to easily transport all of one’s belongings from place

to place. Aside from this, it does not provide a homeless person with the basic necessities of life.

2.35 Homeless Dwellers Conclusion

The analysis and collection of data on the homeless, “that is, people staying in shelters for the homeless, on the streets, or in other similar settings (e.g., in abandoned buildings, in makeshift structures, or in parks)” (Levinson and Ross 2007, 37) is a key source in understanding the basic daily needs of an individual. These people come from different walks of life and while some choose to be homeless, others are forced into homelessness due to Hawai‘i’s high cost of living. Research has revealed that within the four categories studied, which include homeless shelter residents, tent dwellers, street dwellers, and cart dwellers, the homeless have different ambitions and methods of survival. However, it has been found that regardless of the differing practice patterns, the needs of people are generally the same and to some extent even similar to the needs of people after a natural disaster.

“Basic concerns defined by the homeless themselves [include] shelter from climate extremes, safe storage of personal belongings, personal hygiene facilities, and privacy” (Kronenburg 1998, 69). These concerns are similar to the conclusions derived from the research conducted. Based on the research conducted, among the most common and necessary items were shelter, food, water, warmth, comfort, sanitation, and laundromat services. Sanitation includes means of performing hygienic procedures such as using a toilet, teeth brushing, taking a shower, and shaving. It is argued that of those necessities listed, food, water, and warmth are the most essential to staying alive. Shelter, comfort, sanitation, and laundromat services are secondary necessities that are not required for survival. Following those were protection from the elements and storage. Other useful features include means of communication, companionship, and entertainment. Surprisingly, safety and protection were not a strong concern for the homeless, and while these people are aware of the dangers of theft or assault, their lifestyles are not centered around the prevention of either.

To better understand the needs of homeless people, a chart has been created, see Figure 22. In addition to displaying the needs of the homeless, this chart explains how their needs are achieved. It points out whether or not their needs are reliant on permanent buildings; if not, there is a number that corresponds with the numbers found under the section called Solution. Within this section, the methods used to obtain these

necessities are shared. In most situations, these solutions reveal the personal belongings that a homeless dweller carries. For instance, by referring to the chart, it is found that tent dwellers do and do not rely on the services of a permanent building to obtain food. For those who do not, solution #7 reveals that they purchase food at the grocery store and then store it in coolers filled with ice. Thus, it shows that their personal belongings and needs (in addition to the ones already established) include a cooler and ice.

This study of homeless individuals uncovers useful information regarding the needs of people and their methods of survival. These survival tactics will be considered when designing the prototype. Based on the research gathered, it has been found that many of these people depend on the services provided by permanent buildings. Relating this back to a natural disaster, research has proven that it is impractical to rely on the facilities of a permanent building as they are often unable to challenge the strength of nature. As a result, the majority of the methods exercised by homeless people are inapplicable to the proposed prototype. Regardless, the analysis of the four categories of homelessness highlights both their strengths and weaknesses.

Of the categories developed, homeless shelter residents are the ones that heavily most rely on permanent buildings. Naturally, there is a logical explanation as a homeless shelter is a permanent building. Furthermore, its purpose is to target displaced people and provide them with amenities required for life survival. Identical to a home, residents are given a place to sleep and store their personal belongings; sanitary facilities to shower, use the toilet, and perform other hygienic procedures; and food to keep their bodies nourished. Practically everything that a person needs for survival is found at a homeless shelter. And when the shelters are closed, another building that homeless shelter residents make use of is the library. The library is a beneficial place to visit because it is essentially free and provides visitors with a number of amenities such as open access, comfort, sanitation, communication, companionship, and entertainment. Certainly, since homeless shelter residents are frequent users of permanent buildings, it comes with no surprise that these residents do not present exemplary methods to follow. Other homeless people have opposing lifestyles that are more relevant to the proposed prototype.

Compared to homeless shelter residents, tent dwellers relate more to victims of natural disasters as they do not rely solely on permanent buildings. Generally, tent dwellers live in tents along the beach or in parks and depend on public restrooms for

their hygienic needs and grocery stores for their everyday survival items. These homeless people live almost independently from programs and organizations that are developed to assist homeless individuals, and oddly, even though their survival methods are not reliant on permanent buildings, their lifestyles are still somewhat irrelevant to the proposed prototype. This stems from the fact that these displaced individuals depend on the use of bulky items that are heavy and not conveniently portable. In spite of this, there are a few noteworthy techniques that are presumably applicable.

As people who live outdoors, illegal campers experience all types of weather conditions, and thus, have designed and organized their tents to cater to these situations. More specifically, for extra protection from the elements, a tarp is layered over their tent and heavier items are strategically placed inside. These solutions are not technical and can be easily modified to suit the needs of the proposed prototype. Furthermore, these strategies bring about multifunctional features that are more specifically found in the use of the tarp. In addition to providing protection from the elements, a tarp creates an outdoor vestibule space where inhabitants can gather and the ropes that anchor it down can be used to hang laundry that at times is washed with ocean water. The ability to find multiple uses for single objects is an essential quality that the prototype should embody.

Another valuable trait is mobility because it allows for ease of construction and dismantling. This trait is achieved with the use of tents, however, when faced with issues of moving, it is not quite easy as these homeless dwellers have too many personal belongings to carry to the next site. So while the tent is easy to assemble and transport, the items stored inside and outside of it are not. Troublesome items include cooking equipment such as portable gas-powered stovetops and barbecue grills. This shows that in times of a natural disaster, it is of greater benefit to rely on food that can be eaten instantly and does not require cooking. Another object that is found in the tent, but is considered trouble-free is a blanket. A blanket provides the homeless with warmth and comfort. It is important to possess a comfort object for the simple reason that it is uplifting and can increase a victim's mental and emotional well-being.

While the lifestyle of tent dwellers reveals a number of practices that disaster victims can exercise, the daily life of a street dweller does not. Street dwellers are homeless people who have improvised shelters or no shelter at all. These people acquire the materials for their shelter from random places, and if scraps of material are not found, they will sleep beside the few possessions they own and without a roof over

their heads. Most of the time, the materials used are low-tech and not creditable for the proposed prototype. When their makeshift shelters do not provide enough protection from the elements, street dwellers depend on their clothing or the corners of building fronts to find warmth. Street dwellers are found everywhere and although these people do not take refuge in homeless shelters, they utilize the services provided by shelters for obtaining meals, maintaining hygiene, and doing laundry. When not taking advantage of the shelters, their hygienic needs are fulfilled by utilizing the public restrooms in parks or public sidewalks. Compared to the needs of homeless shelter residents and tent dwellers, the needs of these people are little. This explains why they can travel with only a few items that usually fit inside a backpack, luggage, or wheeled container. Overall, the methods practiced by street dwellers are unsuitable for integrating into the proposed prototype.

The last category studied was cart dwellers, and similar to the research found on street dwellers, these individuals do not practice a number of exemplary methods. The only and most obvious feature that is worthy of duplication is their mobility. As people who rely on carts for storage and travel, they are able to trek around more easily and prevent bodily stress.

In general, the study on homeless dwellers reveals many surprising ideas that are impractical to apply to the proposed prototype. More specifically, the lifestyles of homeless shelter residents, street dwellers, and cart dwellers do not offer model ideas. The way of life of a tent dweller is a more valuable model to follow. Regardless, all categories of homelessness reveal information about basic life sustaining needs. Without this information, the design portion of the proposed prototype would not be possible.

HOMELESS DWELLERS

	NEEDS															KEY
	SHELTER	FOOD	WATER	WARMTH	COMFORT	PROTECTION FROM THE ELEMENTS	SAFETY	SANITATION	STORAGE	LAUNDROMAT SERVICES	COMMUNICATION	COMPANIONSHIP	ENTERTAINMENT			
HOMELESS SHELTERS	▲	▲	▲	①	②	▲	▲	③	▲	▲	④	⑤				
TENT DWELLERS	⑥	⑦	⑧	⑨	⑩	⑪	▲	⑫	⑬	⑭	⑮					
STREET DWELLERS	⑯	▲	▲	⑰	⑱	⑳	▲									
															SOLUTION	
<ol style="list-style-type: none"> 1. The use of a long sleeve garment keeps displaced individuals warm. 2. Soft grass brings comfort to homeless shelter residents that are either too late to meet curfew or forced to leave due to shelter hours. 3. The use of a backpack allows the homeless to travel with their belongings more easily. 4. Displaced individuals find companionship in the homeless community. 5. The homeless have many ways of entertaining themselves and this includes aimlessly wandering around, hanging out with friends and watching television. 6. Tent dwellers set up camp along the beach and in parks by using store bought tents that are at times modified with an additional layer of tarp or sheet. 7. Illegal campers are fed through the food supplied by local food banks or purchases from nearby grocery stores, then these items are stored in coolers filled with ice. To cook these items, a stove powered by propane or a barbecue grill are used. 8. Illegal campers purchase water from nearby grocery stores and store it in coolers filled with ice. 9. The use of a long sleeve garment or blanket keeps displaced individuals warm. 10. The use of objects that are soft and/or cuddly, such as a blanket or folding mattress, provides comfort to a homeless person. 11. For extra protection from the elements, a tarp that is either supported by steel poles or ropes is layered over the tent. In addition, some people strategically stabilize a tent by placing certain items inside, such as a folding mattress, baby crib and containers. 12. A variety of containers are used to store their belongings, however a common size used is the 30-gallon plastic bins. In these containers are clothes, food, utensils, blankets and medicine. 13. The ocean water is at times used for washing clothes. 14. Displaced individuals find companionship in the homeless community. 15. Tent dwellers find entertainment through the ownership of a dog and by enjoying the beach. 16. Street dwellers either have no shelter or they “improvise shelters of plastic sheeting, cloth or cardboard, sometimes clustering together on the pavement or empty private or public space close by” (Levinson and Ross 2007, 378). 17. The use of a long sleeve garment or blanket keeps displaced individuals warm. In addition, these people take refuge in the corners of buildings and alleyways. 18. Comfort is provided to street dwellers by placing some type of mat on the ground or using soft objects such as a blanket. 19. The improvised “shelters of plastic sheeting, cloth or cardboard” are used to protect the homeless from the elements. 20. Street dwellers use the sidewalk or other random spaces when public restrooms are unavailable. 																

Figure 22 Homeless Dwellers Matrix

2.4 Minimal Structures Conclusion

This collection of data on indigenous shelters, low-income housing, and homeless dwellers confirms the everyday survival needs of people and uncovers their methods of achieving such necessities. As three different topics have been researched, a number of survival methods have been examined. Although most are inapplicable, the research still brings to light what design considerations should be made for the proposed prototype. This set of information will influence many pivotal design decisions and will be a driving force in the final outcome of the prototype.

Chapter 3

Current Technologies

The use of technology has significantly affected architecture and architecture's ability to protect mankind from the natural environment. While, the overall effort of architecture has succeeded in providing protection, safety and security for humans, natural disasters have the power and force to change the role of permanent architecture in a matter of seconds. In these situations victims turn to the technologies of urban nomads as their lifestyle is more inventive and offers better alternatives to an unfamiliar moment. In order to gain knowledge on the technologies of urban nomads, a study that concentrates on the sophisticated inventions of today has been conducted. To help keep research applicable, wearable architecture, branded materials, survival tools and advanced materials have been analyzed as it concentrates on existing technologies that are similar and relevant to the proposed prototype.

Wearable architecture concentrates on original garments that can support fluctuating setting and function demands as a result of its transformative features. In addition, it focuses on clothing that can stretch beyond its conventional use and thus, adapt to the environment and provide a multi-functional space for users. Its beginnings date back to the Suitaloon by Michael Webb and although the development of clothing-like environments is not among the list of mainstream research topics, there is an emerging community of artists that exist. These people are known to merge the disciplines of architecture, product design and fashion and often times their work consist of outfits that convert into a tent-like structure. Specially designed wearable shelters that are adequately equipped and able to switch into a tent are appropriate for disasters as it is an upgrade from using conventional tents that are generally used as a common solution after a disaster. Often times these tents provide shelter, but are not fully equipped with supplies and necessities to cater to a victim's needs. According to Ruth

Slavid, “the tent is usually either a basic structure in which to rough it, or a high-tech solution for people in extreme environments, [however] it has another and darker use. One of the sights following any disaster, natural or man-made, is the sea of tents that springs up to house refugees. In many environments they do not provide adequate shelter so inventive minds have turned to better alternatives while still keeping the advantages of low cost and speed of delivery and erection” (Slavid 2007, 93). In this study, a number of inventive minds will be discovered and their level of success will be measured in accordance with its relationship to natural disasters.

While wearable architecture focuses on the work of artists who generally do not sell their work, the study of branded products takes a look at established companies whose main goal is to provide quality products for the everyday buyer. Many companies strive to provide consumers with the best products and this means products that are durable, timeless and perform well. In an effort to stay at the forefront of outdoor fashion and gear, companies conduct ongoing research and perform tests to ensure that quality products are being retailed. Unlike independent designers, companies are more financially stable and thus are able to develop and constantly produce new and finely tuned materials. Overall, the design of the merchandise is exceptional; however for purposes of this research the majority of the brands studied will focus on the specifications of each product. This involves more quantitative investigation that will document more technical details that are based on fact instead of judgement.

In addition to studying the products of well-established companies, survival products will be researched. These survival products are tools that are commonly found in survival kits and are considered to be valuable items for staying alive. These tools have been chosen for the reason that each invention addresses one of the needs revealed in the data collected in Chapter 1 and Chapter 2. Unlike the information gathered on branded products, this set of information is aimed at uncovering products that can complement the design of the prototype. Instead of analyzing the physical attributes of each product and trying to find potential features that can be followed, these items will be looked at holistically and evaluation will be based on the effectiveness and usefulness of each tool in times of a natural disaster.

Wearable architecture, branded products and survival tools have been chosen for the reason that each subject is already a characteristic of the prototype or a contributing factor to the design of the prototype. This information will help advance the specific design qualities of the prototype and thus bring it to new heights. In addition, it

will reveal existing ideas that can be refined and altered to meet the needs of the wearable disaster kit. Furthermore, the progress on the world's advancements will be uncovered, which will then give insight of the opportunities and constraints of each invention. Using the information gathered about the opportunities, favorable features will be considered for the proposed design and with the constraints creative thinking will direct these limitations into prospective elements as well as reveal attributes to be avoided.

3.1 Wearable Architecture

Michael Webb of the avant-garde architecture firm Archigram brought the attention of wearable architecture to the world in 1966. His legacy of clothing for living-in has intrigued and attracted numbers of people and his project titled Suitaloon has been an inspiration for many artists today. These artists explore the value of wearable architecture with a different design concept, but with a similar goal in mind. And that is to create an original garment that can support fluctuating setting and function demands as a result of its transformative features. In addition, it focuses on clothing that can stretch beyond its conventional use and thus, adapt to the environment and provide a multi-functional space for users.

Another way of viewing wearable architecture is by considering it a classification of flexible architecture and the reason being that it follows similar characteristics and ideas of flexible architecture. Robert Kronenburg gives insight about the role of flexible buildings and he states,

Flexible architecture requires an attitude to design that integrates the requirements of the present with the possibility to adapt to changing situations in the future. It is not about predictive design (except in the sense that the prediction is that it will be different from the present), as predictions can be, and usually are, wrong. It is about allowing future users and designers, who will know their own situation best, the leeway to make appropriate decisions when they are needed. This can take the form of spaces and elements that are easily manipulated and altered on a day-to-day basis, or the capacity to be changed fundamentally with minimal disruption and expense as circumstances develop over a long period. This does not mean that architects now need to focus on designing loose-fitting, non-dedicated environments without character. Instead the ambition should be to create buildings that have integrated, carefully devised

systems that are capable of responding to new and varied situations. This is architecture that needs designers' skills more than ever, not to create a product that is perfect on delivery (but destined for compromise in the future) but one that is capable of taking advantage of other contributors to the building's operation (most importantly the users) during its future lifetime (Kronenburg 2007, 110-111).

Kronenburg clearly defines flexible architecture and the objectives behind these building typologies. It is argued that wearable architecture fulfills the description of these guidelines as the flexible garments that evolve into flexible shelters are designed to accommodate the present needs of users while integrating design details that easily adapt to the future needs of the user. Specifically for disaster relief, wearable architecture is a “responsive, supporting strategy that enables local people to direct their own needs” (Kronenburg 2007, 110).

As mentioned earlier, more artists are emerging in the field of wearable architecture. These artists include Takehiko Sanada (designer of Prefab Coat), Kotsuke Tsumura (designer of Final Home Jacket), Justin Gargas (designer of Vessel) and Lucy Orta (designer of Connector Mobile Village). The work of these artists are not exclusively designed to address the concerns associated with disaster relief, however each design has a feature or two that can aid a victim. In an effort to keep data organized and relevant, the following criterion has been used to analyze the success of each prototype:

- Versatility: the ability to adapt to different situations and respond to unexpected events
- Materials: understanding the type of fabrics and contents used to protect users from the elements as well as to help increase the lifetime of the garment
- Ventilation: the use and incorporation of openings in the design in order to ensure proper air flow
- Lighting: simple consideration of natural lighting versus artificial lighting
- Comfort: the level of physical well-being or relief that a user experiences
- Construction: the technique in which the work is constructed as well as the hardware used
- Transportation: focus on the ability to heavily rely on wearing the shelter as a means of transportation

The research uncovered in these projects of wearable architecture will reveal

technologies that are worth duplicating as well as inventions that require fine tuning in order to suit the proposed prototype.

3.11 Prefab Coat

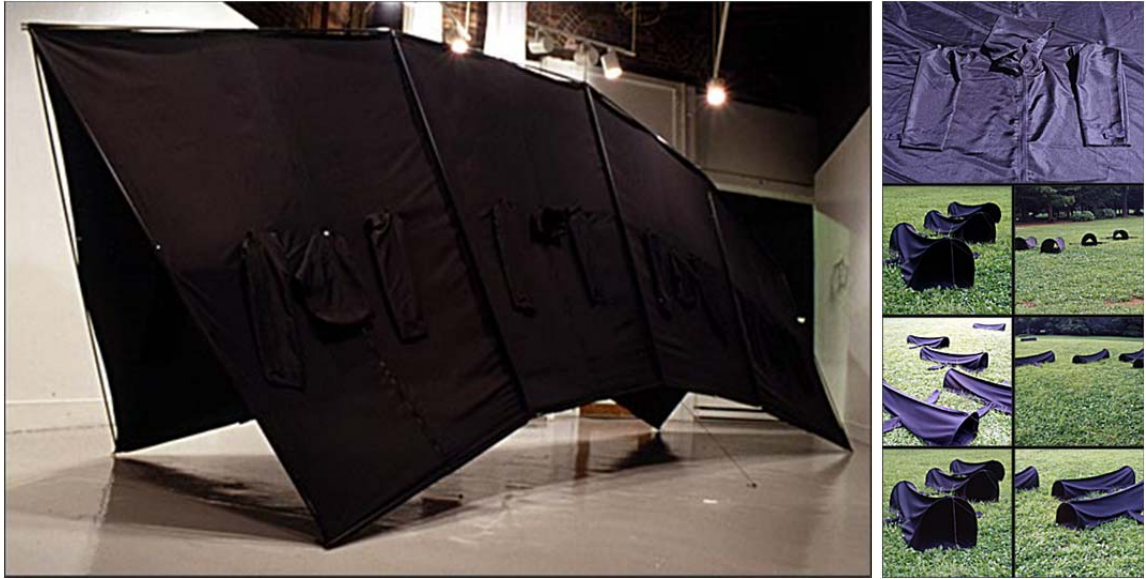

Figure 23 Prefab Coat by Takehiko Sanada. Garment can be used as a blanket, sleeping bag or tent.

In 2000 Japanese designer Takehiko Sanada created the Prefab Coat. The Prefab Coat is “a garment [made of] recycled polyester which, when unzipped, can be supported on poles and used as a shelter” (Slavid 2007, 93). It has a fastener that is located at the hems of the coat and when this feature is applied the Prefab Coats are able to connect and thus, create a larger shelter. The dimension of each Prefab Coat measures at 70.9 in x 66.9 in x 1.2 in.

Sanada sets an inspiring precedent for the future of wearable architecture. The design is very simple and reminiscent of a conventional tent, and while it may not be completely suitable for post-disaster situations it addresses a few things that the proposed prototype shall embody and it also sparks creativity in a way that will allow certain constraints to become opportunities. One of its fascinating features is versatility; this includes its ability to extend and expand into a shelter for one or numerous users and its ability to transform into a blanket, sleeping bag and tent. Another exemplary feature is the material used, which is polyester. The last features analyzed do not embody exemplary opportunities that are worth duplicating and this includes ventilation, circulation and lighting.

The Prefab Coat is crafted to be a multi-functional article that can suite a number of users; however there are certain transformations that work better than others. Starting off with the weaker aspects is the Prefab Coat as a blanket. This function is basically a default feature for the reason being that aside from the fabric used for the head and arm components, the cut of the garment is equivalent to that of a blanket. Following the blanket attribute is the sleeping bag. The sleeping bag is a small space that looks rather uncomfortable with little space for movement. It is intended for a single occupant, which is not an ideal characteristic for the prototype. In addition, due to its structure and size there is no room to store objects for survival. The last transformation, which is the tent, is a noteworthy function that can use a few constructive adjustments. Cunningly, “two people can zip their coats together to form a tent for two. And larger numbers can also create an appropriately larger dwelling” (Slavid 2007, 93). The ability to expand into a coat house (shelter for two people) and a dome house (shelter for more than five people) is an incredible feature that parallels with the future design of the prototype. As it is common for people in Hawaii to have large families, it is essential that the post-disaster garment have a built-in feature to expand. Particularly, the expansion mechanism that is developed for the Prefab Coat is somewhat cumbersome. It is only applicable when there is an even number of Prefab Coats because theoretically, if only one garment is present then there is only enough fabric to erect a wall. Also, when constructed into a coat house, the tent offers a less than substantial amount of space for a family; however when four garments are used the size seems appropriate. Overall, the Prefab Coat has initiated an excellent step towards multi-functional fabrics that are suitable for recreational activities and not so much for post-disaster situations,

The use of polyester as the primary material is an excellent choice as it has many characteristics that are appropriate for an outdoor setting. According to Virginia Hencken Elsasser, features of polyester’s environmental properties include that “mildew and insects will not attack polyester. Long exposure to sunlight will degrade the fiber, but it has better sun resistance than most other fibers. Age has no effect on polyester” (Elsasser 2005, 88). The mechanical properties of polyester include excellent abrasion resistance, strength and resilience, moderate elasticity and it is a medium-weight fiber. Due to its excellence in abrasion resistance and strength the fabric has a longer life, can maintain its original appearance and resist wear from constant rubbing. With excellent resilience and moderate elasticity, polyester is a common fabric that is used in blends as it has an exceptional ability to return back to its original physical condition after stress is

removed (Elsasser 2005, 88-89). The chemical properties of polyester include “low absorbency and average wicking ability,” (Elsasser 2005, 88) which means that it can dry quickly and draw moisture from the skin to keep users feeling cool and dry.

While the Prefab Coat may have many advantages, there are a few limitations that can be further developed through constructive design decisions. Beginning with ventilation, this structure lacks the ability to control the amount of ventilation entering the tent. Unlike other tents that have zipper controlled openings that double as both a door and window, this tent has no device to cover the arched openings on the bottom of the coat house walls and the openings that serve as the entrance and exit. With the use of controlled openings, it will increase the level of security and weather protection for users. The second feature that can be built upon is circulation. As larger amounts of coats transform into one large tent, the circulation within the space becomes less ideal for occupants who are positioned in the middle. It is believed that a convenient entrance and exit be accessible for all users to easily travel in and out of their tent space. The last feature analyzed is lighting. Being that the fabric color is black and the design lacks windows the light penetration throughout the space is questionable. One might argue that a lighting device may be a sufficient method for this issue; however a more simple solution may be a change in fabric color.

3.12 Final Home Jacket



Figure 24 The 44 pocketed Final Home Jacket by former Issey Miyake employee, Kotsuke Tsumura.

Kotsuke Tsumura is a fashion designer from Saitama, Japan who created a brand named Final Home. Its first product and also the reason for the brand's existence is Final Home Jacket. This item was "the starting point [for the] brand and also a product which perfectly [embodied] the brand's concept of survival, protection, functionality and recyclability" (Final Home n.d.). A description provided by Bradley Quinn states that

The jacket is a multi-functional, transparent, nylon sheath, equipped with forty-four zipped pockets creating folds and geometries that redefine conventional body shapes and fabric cuts. The pockets function as compartments, providing the wearer with plenty of space to store belongings. Pockets hidden inside the jacket can be lined with warm materials for extra insulation, or cushion the wearers when they sit or recline. The transparency of the outer pockets enables the wearer to customize the surface of the jacket, filling them with pictures, postcards or artwork to create different surfaces. Tsumura also suggests that some of the pockets be stocked with survival rations and a medical kit, equipping the jacket with the potential to provide first-aid assistance in medical emergencies. Each jacket features a label sewn on the sleeve for the wearer to write in their blood type and vital statistics in case of emergency, literally providing the means to wear your life on your sleeve (Quinn 2003, 101-102).

While certain audiences argue that Final Home Jacket fits within the category of wearable architecture, others argue otherwise as proven by its failure to transform into an actual shelter. In essence, Final Home Jacket is a jacket that provides shelter for a person's body. The multi-pocketed system of Final Home Jacket is a commendable feature; however aside from that and a few other noteworthy qualities it does not share valuable possibilities for the proposed prototype. Of utmost concern from its lists of drawbacks is the comfort of the garment. As Final Home Jacket falls short of being a building, the main features analyzed consist of the multi-pocketed systems, fabric type, label sewn and comfort.

The many pockets found along the entire jacket are a handy attribute that allows individuals to travel with many items while keeping their hands free. The items carried can include supplies that will be of great use in times of an emergency as well as supplies for everyday essentials. With 44 pockets incorporated into the design, it eliminates the need for purses and other similar gear. However, with the ability to hold so many items, the comfort of the jacket is doubtful. It seems that problems may arise as the filled compartments become bulky because it limits the movement of the user.

Thus, the user no longer has control of the garment, but instead the garment has control over the user.

The material used is a transparent nylon sheath that is waterproof and stretchable, both of which are beneficial characteristics that should be incorporated into the proposed design. The transparent property of the fabric is more of an aesthetic quality rather than a functional quality. It is suggested that sentimental keepsakes and possessions, such as photos, cards or artwork, fill these pockets as a way to customize its appearance. The stretchable attributes of the fabric allow the “pockets hidden inside the jacket [to be] lined with warm materials for extra insulation, or cushion [for] the wearers when they sit or recline” (Quinn 2003, 101). Users are able to fill these individual compartments with their own personal warm materials or purchase accessories, from the Final Home company, that are specially designed to fit into the pockets. As previously mentioned, there is some doubt in the success of a lined jacket’s comfort.

The last admirable quality is the sewn label that allows people to write their personal information in case of an emergency. The blank information to be filled in includes a person’s name, date of birth, sex, blood type, address, phone number and emergency contact. These vital statistics are an extremely useful feature that helps in identifying unresponsive people. There are many victims of forewarned natural disasters who could have benefited from this label on Final Jacket Home. Not only does it help rescuers immediately identify a person, but it also takes the guess work out.

3.13 Vessel



Figure 25 Vessel by Justin Gargasz. Multi-functional garment that can transform from a jacket, reversible jacket, sling bag or tent.

Vessel was designed in 2009 by Justin Gargasz, a recent design student at the Cleveland Institute of Art. Vessel is a brilliant example of wearable architecture as it

transforms from a jacket, reversed jacket, sling bag or tent. The idea behind Vessel began with Gargas's survey that revealed all people except for 10% believe that it is impossible to escape from interactions in their everyday environment. By using the data collected, Gargas began his concept exploration on expandable clothing and since its completion he has received a lot of praise for his excellent design.

As described by Gargas, "Vessel is a medium weight reversible jacket that can expand into a cocoon or collapse into [a] sling bag. Used whenever one feels the need to escape interactions in their present environment. It is integrated into an everyday article of clothing to function physically and psychologically. Carrying this product around the user knows they can get away when they need to" (Gargas n.d.). While the purpose behind Vessel differs from that of the proposed prototype, the qualities integrated into the design are possible amenities that the proposed prototype will embody. Based on the criteria used to analyze the appropriateness of each garment in a disaster situation, Vessel addresses each category except for construction. The other categories, which include versatility, materials, ventilation, lighting, comfort and transportation, have been well thought out by Gargas and are strategically accommodated for.

Unlike other garments that fall under the class of wearable architecture, Vessel has an overall appearance that looks identical to a conventional jacket. Aesthetically the garment looks pleasing, which is a great compliment to its functionally pleasing features. Starting with Vessel's multi-faceted nature, it has three traveling options. The first two options include traveling with Vessel as a jacket or a reversible jacket. These options are preferable on a breezy day, however when the weather is feeling warmer the third option of traveling with Vessel as a sling bag can be utilized. This form is achieved by folding the head and waist opening towards the chest, making sure that the fold is perpendicular to the zipper, and then wrapping the jacket around the body with the arms tied together in the front. In addition to these three transformative traveling options, it has a fourth transformative feature that unfolds when the traveling stops. This option is the cocoon, which is a shelter that is erected when the jacket is no longer worn. The body of this shelter is stored in the lower back tubes that are displayed when the reversible jacket is worn. In order to construct this tent the arms of the jacket are tied to a tree and the stored body is then unraveled and anchored down with rope, nails and hooks that are integrated into the design. While the design details of Vessel are quite clever due to Gargas's understanding of the human body and user experience, the

shelter's reliance on a tree for stability is not commendable for disaster relief purposes. In times of a natural disaster it is more beneficial to have specially devised garments that adapt to any environment and not only ones with trees.

The materials selected for Vessel have been well thought out as it attends to the structural, ventilation and lighting demands of the user. The blue outer shell of the jacket is made of Cordura and the beige inner shell is made of 1.1oz silicon impregnated ripstop nylon. According to Gargasz, "different weights of Cordura were used for its extreme durability and stability. Dark Blues were chosen because they are unobtrusive indoors and outdoors. The 1.1oz silicon impregnated ripstop nylon that makes up the bulk of the body of the cocoon is about 90% opaque allowing the user light as well as sounds and smells of the outdoors. On the door is a 1 in strip of mesh so that the person inside can clearly see out" (Gargasz n.d.). The strip of mesh along with the opening located at the feet both ventilates the interior space.

Vessel is a thoughtful invention that presents many ideas that are comparable to the preconceptions made of the proposed prototype. While many admirable qualities have been noted, there are a few questionable features that will be avoided. As Vessel is intended to be a one-person tent, the size of the shelter is not large enough to accommodate a family nor is it able to house supplies for survival. In addition to this, it does not have the ability to expand and connect with other Vessels, however it is understood that if the tent had the ability to unite with other Vessels it would defeat the purpose of escaping from outside interactions. The last debatable feature is comfort, which has been achieved when Vessel is in the form of a jacket, reversible jacket and sling bag, but not in the form of a tent. Again, the comfort of the shelter goes back to its maximum capacity. With room for very little movement it is possible that the user may feel claustrophobic and trapped instead of relaxed and at ease.

3.14 Connector Mobile Village

Lucy Orta is an artist based out of Paris, France who has developed a number of prototypes for social transformation. Her work explores the boundaries and relationships between fashion, architecture and art. One of her works that represents wearable architecture is the Connector Mobile Village that was produced in 2002. As described by Bradley Quinn,

Unlike a series of building that would remain bound to a specific place, the

Connector Mobile Village forms the basis of a mobile community. The work facilitates a modular social network in which individual units can connect together in a variety of configurations, forming sites for habitation, education or exhibitions. Individuals can attach and detach at will to join different parts of the community or reformulate the entire network. 'I wanted to engage the individual Body Architecture units I call "Survival Sacs" within the structure of an architectural hub to create a forum where individuals could gather and retreat to separate spaces when they need to,' Orta explained (Quinn 2003, 101).

Lucy Orta has designed an incredible shelter that has succeeded in its goal of keeping families together. The intention behind this project parallels very strongly with the objectives of the proposed prototype as both are aimed to provide a mobile environment of support and stability for large families. For this reason, the Connector Mobile Village is an excellent prototype to analyze. The first area of interest looks at the versatility of the shelter's two components when each piece stands alone as individuals versus a collaborative effort. The second area of interest focuses on the comfort of the space and how the materials used support this feature. The last area of interest studies the ventilation and lighting. Investigation of this piece will bring a new understanding of how other artists have addressed the same concerns of the proposed prototype.



Figure 26 (left) Connector Mobile Village by Lucy Orta. (right) Various Survival Sacs designed by Orta in 1996. Although these are not the exact sacs that are used in the Connector Mobile Village, it works similarly.

The design and construction of the Connector Mobile Village consists of two separate entities, the larger scale domes and Survival Sacs. The larger scale dome is a non-wearable tent-like structure that is supported by lightweight and telescopic structures. The Survival Sacs are wearable garments that can be zippered onto the hub. As individual entities, the Survival Sacs work more favorably than the dome. Without the survival sacs, the purpose of the dome becomes less important and begins to identify

with other typical tents. However, due to the versatility of the sac it maintains its level of purpose because it can be worn as a protective garment and used as a sleeping bag. When used as a garment, one can find a zipper that runs around the fabric at below knee level. In order to connect the Survival Sac to the dome, the garment must be unzipped to remove the bottom portion then the top portion is zippered to the dome. When both components collaborate with each other the piece has reached its full potential and becomes highly relevant to disaster relief. Due to its unique design it can accommodate six family members, which helps to decrease the possibility of separation among families. It is possible that more people can be accommodated and take refuge here, however their space would be located in the community hub or one could set up their Survival Sac adjacent to the village. Another noteworthy feature provided by the removable sacs is the opportunity to depart from the community lifestyle. While it can be a pleasure to be in the presence of a group, it is also important to have delineating boundaries between a person's sleep and leisure space. At the same time, it is argued that while individual spaces provide a space of retreat, it is not appropriate for all ages. It is believed that vulnerable and young children need the intimacy that a large tent space would allow a parent to provide.

Another factor in determining the success of the Connector Mobile Village is comfort. There are a couple of features that contribute to the comfort of this village and this includes materials and ergonomics. The materials of the Connector Mobile Village include aluminum coated polyester and three telescopic aluminum armatures for the dome and reversible Solden Lycra, rip stop with polyurethane, silkscreen print, zippers and six armatures for the Survival Sacs. Orta has strategically chosen these materials as a way to provide comfort and durability to users and she states that

the forms [of the Survival Sacs] allow for a minimum space around the body, the notion of space is essential to the development of the person inside. The materials are chosen for their "comfort seeking" properties further extending the metaphorical properties of the objects; a combination of microporous rip stop with a PU coated polyamide which takes into account both the abrasion during mobility and the necessity for body comfort. The habit-bivouacs have carbon structural armatures that raise the fabric above the chest to eliminate the effects of claustrophobia. They often have arm or hood appendages that assist the inhabitant in developing relationships outside the environment, other pockets containing both functional and symbolic objects (Orta 2006).

As for the dome, Orta reveals that “the aluminum surface of a coated polyamide...can be placed exterior to reflect the sun's rays or interior to reflect the body's heat. It is the idea that our body is in complete interaction with the surrounding environment, that we determine the harmony within our habitat” (Orta 2006). It is agreed that the details of Orta’s design reveals her mature level of understanding for the human body as well as the environment. As a result, the comfort ability of the village has been reached and the use of materials is a potential option for the proposed prototype.

The ventilation and more specifically the lighting techniques of the Connector Mobile Village are a little unclear, however based on speculation there are a few comments. It seems that the amount of fresh air entering the dome space is dependent on the amount of Survival Sacs that are attached to the dome. When all six sacs are attached to the hub, there is no fresh air entering the dome aside from the air that circulates through the Survival Sacs. However if there is less than six sacs attached to the hub, then the dome’s interior has more exposure to air. As for the Survival Sacs, there are various areas that allow fresh air to enter and this is through the head opening, pockets and appendages.

3.15 Wearable Architecture Conclusion

After careful analysis of each work, which include the Prefab Coat by Takehiko Sanada, Final Home Jacket by Kotsuke Tsumura, Vessel by Justin Gargas and the Connector Mobile Village by Lucy Orta, it has been proven that each piece was highly successful in executing its design concept, and as a result certain features are not appropriate and suitable for aiding victims in a disaster situation. However, regardless of the concept behind each project, each artist created a work of art that features unique attributes that still can be applied to the proposed prototype. In an effort to effectively organize the lengthy data and observations that were made, a short chart has been prepared, see Figure 27. This chart shows a collection of information that is based purely on fact and not on judgment. By organizing data in this manner, it allows for a quantitative rather than a qualitative set of information.

The Wearable Architecture Chart is based on the criterion that was used to analyze each model. This includes the categories of versatility, construction, transportation, materials, ventilation and lighting, with the addition of two new categories, storage and expansion. These two categories were inserted after particular garments brought attention to the importance of its existence. Also, as a result of organizing the

WEARABLE ARCHITECTURE CHART





	PREFAB COAT	FINAL HOME JACKET	VESSEL	CONNECTOR MOBILE VILLAGE
				
VERSATILITY	<ul style="list-style-type: none"> • Blanket • Sleeping Bag • Tent 	<ul style="list-style-type: none"> • Jacket with 44 pockets 	<ul style="list-style-type: none"> • Jacket • Reversible Jacket • Sling Bag • Tent 	<ul style="list-style-type: none"> • Garment • Survival Sacs • Village with reversible fabric
CONSTRUCTION	<ul style="list-style-type: none"> • Fasteners • Zippers • Poles • Rope 	<ul style="list-style-type: none"> • Zippers 	<ul style="list-style-type: none"> • Nails • Rope 	<ul style="list-style-type: none"> • Dome: Telescopic aluminum armatures • Survival Sacs: zippers and six armatures
TRANSPORTATION	Wearable	Wearable	Wearable	Wearable
MATERIALS	Recycled Polyester	Transparent Nylon Sheath	<ul style="list-style-type: none"> • Cordura • 1.1 oz impregnated silicon nylon ripstop 	<ul style="list-style-type: none"> • Dome: Aluminum coated polyester • Survival Sacs: Reversible Solden Lyrca, ripstop w/ PU
VENTILATION	Yes	N/A	Yes	Yes
LIGHTING	Natural	N/A	Natural	Natural
STORAGE	No	Yes	No	No
EXPANSION	Yes	No	No	Yes (Limited)

Figure 27. Wearable Architecture Chart based on the criteria used to analyze each garment.

chart with quantitative information, the category of comfort was removed because it is considered to be qualitative research. The data collected on the precedents of wearable architecture reveal interesting information that will be used to design the proposed prototype. While the analysis found in sections 3.11-3.14 passes judgment on the advantages and limitations of the precedents, this quantitative portion will not.

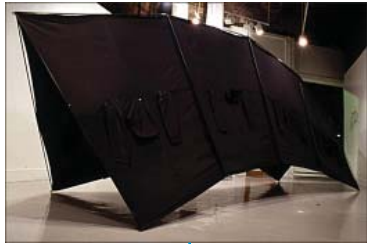
Beginning with versatility, each garment has made it clear that the prototype must be flexible and easily manipulated in order to respond to the needs of the user. And in an effort to support the shelter's versatility, all models must be transported by wearing it to destinations. The materials and construction between the four models vary showing that there are multiple ways that a shelter can be erected. However, common hardware that is used by most is zippers and poles; and common fabrics include those that have durable and resilient properties. For the three garments that transform into a shelter, the space is lighted with natural lighting instead of artificial lighting and a type of ventilation system is considered. Among all models, it was not common to incorporate storage space for users and only half incorporated an expansion option. Although comfort was not included in the chart that is not to say that it is not important. As each precedent was not physically explored it is impossible to rate the level of comfort in each model. Instead speculations were made and it is assumed that the one person tents of the Prefab Coats, Vessel and Connector Mobile Village are uncomfortable as it is a tight space. While Orta has developed a carbon structural armature to address the claustrophobia of the user it still does not suffice the limited movement of a user.

In each garment examined there is a leading feature that will be considered for the design of the proposed prototype. The Prefab Coat is an inspiring precedent as it has the ability to expand into a larger shelter by zipping two garments together. This expansion mechanism allows for groups of people to gather and spend the night away from home together. The Final Home Jacket isn't the type of wearable architecture that the prototype will develop into, however the 44 pockets that can be used to stock survival rations is a clever approach to storage. Vessel is a well thought out garment that can transform into four different ways, a jacket, reversible jacket, sling bag and tent. Its multifunctional characteristics do not set it apart from the other precedents studied, however its sleek transformation from a jacket to a sling bag in order to accommodate the body's temperature is. The Connector Mobile Village is distinctive for its use of materials that are specially designed to support and respond to the surrounding environment that could either be cold or hot.

The information collected on wearable architecture will be of great use as well as an excellent tool to reference in the next chapter, when the design of the wearable architecture disaster relief kit is created. The advantages and limitations of the Prefab Coat, Final Home Jacket, Vessel and Connector Mobile Village will aid the development of the design and allow for the invention of unprecedented wearable architecture work. With the use of this information the people of Hawaii will experience and explore the boundaries of wearable architecture that has never been touched.

3.2 Product Design

The study of branded products takes a look at established companies whose main goal is to provide quality products for the everyday buyer. Many companies strive to provide consumers with the best products and this means products that are durable, timeless and perform well. In an effort to stay at the forefront of outdoor fashion and gear, these companies conduct ongoing research and perform tests to ensure that quality products are being retailed. To keep research relevant, brands that produce sportswear and are geared towards outdoor activities will be investigated. This includes Patagonia and the North Face. Although the overall design of their merchandise is exceptional, for purposes of this research the specifications of each product will mainly be researched. This involves documenting more technical details that breakdown the components of the design and focus on the functional aspects.

Patagonia is a well-known clothing company that specializes in outerwear for all types of weather and environments. This company sets itself apart from other leading companies as it has crafted a number of original fabrics that are used in many of their products. These fabrics are designed with physical, mechanical and chemical properties that are strong, long-lasting and high performance. It is due to these characteristics along with the success of the company that the area of focus will be on fabric selection. Knowledge of this information will determine what fabrics are appropriate for the prototype as well as the activities that will be performed.

The North Face is another well-established American company that specializes in outerwear and equipment as well. In order to gain a wealth of knowledge on outdoor supplies, research will be focused on tents produced by the North Face. The opportunity to study the diverse sets of tents will reveal basic information, such as the tent area to occupancy ratio, materials used, dimensions and etc. This information will be extremely

helpful in defining the design of the prototype.

The brands of Patagonia and the North Face have developed a unique quality that has brought them to the forefront of retail. As each offers a different insight to outdoor supplies, it becomes an advantageous topic to study. For instance, when these individual components that are studied are formulated into one object it creates an exceptional product. The chosen areas of focus for each brand will explore the finer details of the product and by understanding the brand's successful techniques; it will be a useful tool when crafting the prototype.

3.21 Patagonia

Since its establishment in 1972 as a climbing hardware equipment company, Patagonia has come a long way and has opened its doors to other marketable products. Particularly, this includes the various clothing fabrics and technologies that continue to adapt to the changing needs of the environment. In Patagonia's beginning years its clothing line consisted of polypropylene and piling, and while both were successful materials, it had its fair share of problems. As a way to remain at the forefront of outdoor clothing and more importantly to improve the quality of their goods, a substantial amount of time was invested in research and design. This move prompted the creation of their very own fabrics named Synchronilla and Capilene. Today, Patagonia continues its successful research efforts as proven by the number of noteworthy materials it has produced. Among all of their clothing fabrics three categories, which include hard shell, soft shell and hybrid, have been created to help organize the vast amount of products carried. While hard shell products represent fabrics that are waterproof, soft shell products are not waterproof and as for hybrid products, both hard and soft shell fabrics are integrated into the design.

Patagonia's primary material for hard shell fabrics is called H2No. "H2No is Patagonia's standard for 100% waterproof and breathable protection in [their] shell garments. H2No is created by adding a waterproof and breathable laminate or coating to a high performance protective fabric. This fabric package blocks wind and water on the outside while allowing water vapor generated by your body to escape – keeping you warm, dry and comfortable" (Technology: H2No® Waterproof Breathable Barrier n.d.). This original fabric shares similar characteristics to Gortex and comes in three different layers: 2-layer H2No, 2.5-layer H2No and 3-layer H2No. Until recently, Gortex was used in many of Patagonia's products, however due to the company's environmental

initiatives the use of Gortex was phased out and H2No emerged. Among the three different layer types, each fabric is completely waterproof, windproof and breathable. The numerical value of each layer represents the amount of layers in each type as well as its durability. In each of the three H2No fabrics there is a one common layer found and that is the waterproof H2No barrier. To further explain their differences, the 2-layer H2No shell fabrics have “an internal mesh or a wicking, hanging fabric liner,” (Technology: H2No® Waterproof Breathable Barrier n.d.) and the 2.5-layer H2No shell fabrics have “a water-repellent shell fabric and a raised pattern on the inside, instead of the full-coverage scrim used in the 3-layer fabrics” (Technology: H2No® Waterproof Breathable Barrier n.d.). Basically, the higher the number the more durable and tear-resistant the fabric will be, which means that 2-layer fabrics are more prone to abrasion than 3-layer fabrics.

Unlike hard shell fabrics, soft shell fabrics are water-resistant and highly breathable materials. The soft shell fabrics of Patagonia consist of Capilene and Merino Wool to name a few, and based on Patagonia’s recommendation that Capilene is the “best option for high-sweat activities and wet conditions,” (Fabric: Capilene® Polyester Baselayer n.d.) research will particularly focus on this product. Capilene fabrics are made “for different levels of exertion and temperatures. Capilene is a moisture-wicking polyester fabric that keeps you warm and dries quickly. Capilene is made with recycled fibers, is recyclable when it wears out and features Gladiodor natural odor control” (Fabric: Capilene® Polyester Baselayer n.d.). As stated, it comes in four different options, Capilene 1 Silkweight, Capilene 2 Lightweight, Capilene 3 Midweight and Capilene 4 Expedition Weight. Basically, the higher the number the better it will perform in cold environments and the heavier the fabric will be. According to the sales associate at the Patagonia Soho New York store, Capilene 1 is soft and silky, Capilene 2 is the fastest drying, Capilene 3 is the fastest wicking and Capilene 4 is the warmest. These fabrics have been designed to accommodate to the various activities that people will perform as well as to the needs of users.

It has been learned that soft shell fabrics are susceptible to getting wet and for this reason Patagonia has designed hybrid garments that incorporate hard shell fabrics with soft shell fabrics. Hybrids are designed so that areas that receive more exposure to water will be layered with a hard shell. These areas usually include the shoulders, arms and hood of the garment. The remaining portion of the garment, which is the torso, is made of a soft shell fabric. To protect the body of the apparel from getting wet it is

treated with a Deluge Durable Water Repellent. While this does not make the fabric waterproof, it repels water and causes it to roll off.

3.22 The North Face

Founded in 1966, the North Face is an American retailer that specializes in outdoor apparel and equipment. Its line of products consists of high performance outerwear, footwear and tents, which are known to “set the industry standard for performance and durability” (Product Technologies n.d.). As one of the leading tent providers in the business, investigation on their line of tents has been conducted. Research in this area required gathering of product information that is also referred to as product specifications. This collection of data will be of great use when designing the prototype as it will be a point of reference.

In an effort to effectively organize the lengthy data and research that was collected, a chart titled the North Face Tent Chart has been prepared, see Figure 28. The categories of the chart include tent series, name, total weight, floor area, floor dimensions, vestibules, vestibule area, peak height, number of poles, doors, sleeping capacity, fabric and technology. After completion of the chart, it was recognized that some specifications do not align with the proposed prototype as it is either too big or too heavy. For those reasons, it has been eliminated from the analysis and the remaining tents have been used to draw conclusions. With the vast amount of information displayed there are many statements that can be concluded. However, in order to draw a limited and systematized conclusion, statements will be made for each column starting from the left to the right.

After certain tents were eliminated, the Three-Season Core, Flight Series and Base Camp tents remained as potential models. However, even within this group there is one that stands out and it is the Three-Season Core. Aside from the fact that the Flight Series does not include a rain-fly and the Base Camp is promoted for its lightweight features, the Three-Season Core is excellent as it is intended for spring, summer and fall and is built to withstand the wind and rain. Although it is not built to handle the winter snow loads, it is still suitable for the weather in Hawaii because it never snows.

The total weight of the tents vary with 3lbs 1oz being the lightest and 8lbs 11oz being the heaviest. There are many factors that contribute to this assessment and this includes the material and size of the tent. For instance, while 3lbs 1oz is considered the

THE NORTH FACE TENT CHART														
	Name	Total Weight	Floor Area	Floor Dimensions	Vestibules	Vestibule Area	Peak Height	# of Poles	Doors	Sleeping Capacity	Fabric			Technology
											Canopy	Floor	Fly	
Summit Series	2-Meter Dome	51 lbs	125 ft ²	diameter 155"	–	–	83"	12	2	8	Nylon Oxford w/ PU coating	Nylon Taffeta w/ PU coating	Nylon Oxford w/ PU coating	–
	Dome 8	57 lbs 11 oz	128 ft ²	diameter 155"	1	34 ft ²	83"	9+1	3	8	Nylon Ripstop	Nylon Oxford w/ PU coating	Nylon Oxford w/ PU coating	DAC Featherlight
	Dome 5	35 lbs	83 ft ²	diameter 120"	1	23 ft ²	67"	9+1	3	5	Nylon Ripstop	Nylon Taffeta w/ PU coating	Polyester Ripstop w/ PU coating	DAC Featherlight, Fusion Pitch
	Him 35	10 lbs 14 oz	37 ft ²	60" x 84"	2	10 ft ² + 5ft ²	45"	3+2	2	3	Nylon Ripstop	Nylon Taffeta w/ PU coating	Polyester Ripstop w/ PU coating	DAC Featherlight
	VE 25	10 lbs 11 oz	48 ft ²	104" x 85"	2	10 ft ² + 5ft ²	48"	4+1	2	3	Nylon Ripstop	Nylon Taffeta w/ PU coating	Polyester Ripstop w/ PU coating	DAC Featherlight
	Mountain 25	8 lbs 9 oz	30 ft ²	unknown	2	7 ft ² + 4ft ²	39"	4+2	2	2	Nylon Ripstop	Nylon Taffeta w/ PU coating	Polyester Ripstop w/ PU coating	DAC Featherlight
Three-Season Core	Minibus 33	7 lbs 5 oz	41.7 ft ²	65" x 92.5"	2	14 ft ² + 14ft ²	48.5"	3	2	3	Nylon Ripstop	Nylon Taffeta w/ PU coating	Siliconized Nylon w/ PU coating	DAC Featherlight
	Manta Ray 33	6 lbs 13 oz	51.51 ft ²	72" x 92"	2	13.5 ft ² + 13.5ft ²	44.5"	3	2	3	Nylon Ripstop	Nylon Taffeta w/ PU coating	Siliconized Nylon w/ PU coating	DAC Featherlight
	Madraque 33	6 lbs 4 oz	41 ft ²	66" x 90"	2	11 ft ² + 11ft ²	45.5"	3	2	3	Nylon Ripstop	Nylon Taffeta w/ PU coating	Siliconized Nylon w/ PU coating	DAC Featherlight
	Minibus 23	6 lbs 12 oz	34.9 ft ²	54.5" x 92.5"	2	11.8 ft ² + 11.8ft ²	42.5"	3	2	2	Nylon Ripstop	Nylon Taffeta w/ PU coating	Siliconized Nylon w/ PU coating	DAC Featherlight
	Manta Ray 23	6 lbs 3 oz	42 ft ²	56.5" x 88.5"	2	11.6 ft ² + 11.6ft ²	44"	3	2	2	Nylon Ripstop	Nylon Taffeta w/ PU coating	Siliconized Nylon w/ PU coating	DAC Featherlight
	Madraque 23	5 lbs 9 oz	34.5 ft ²	56" x 90"	2	8.75 ft ²	42"	3	2	2	Nylon Ripstop	Nylon Taffeta w/ PU coating	Siliconized Nylon w/ PU coating	DAC Featherlight
	Meso 22	4 lbs 1 oz	29 ft ²	48" x 88"	1	13 ft ²	36"	3	1	2	Nylon Ripstop	Nylon Taffeta w/ PU coating	Siliconized Nylon w/ PU coating	DAC Featherlight
	Mica 12	3 lbs 2 oz	17.5 ft ²	37.5" x 86"	1	6 ft ²	37.5"	2	1	1	Nylon Ripstop	Nylon Taffeta w/ PU coating	Siliconized Nylon w/ PU coating	DAC Featherlight
Flight Series	Spectrum 33	4 lbs 12 oz	34 ft ²	86" x 58"	1	9 ft ²	42"	3	1	3	Siliconized Nylon w/ PU coating	Nylon Taffeta w/ PU coating	–	DAC Featherlight
	Spectrum 23	4 lbs 3 oz	28 ft ²	49" x 85"	1	6 ft ²	37"	3	1	2	Siliconized Nylon w/ PU coating	Nylon Taffeta w/ PU coating	–	DAC Featherlight
	Vario 33	5 lbs 3 oz	29 ft ²	64" x 88"	2	10 ft ² + 10 ft ²	43"	3	2	3	Nylon Taffeta w/ PU coating	Nylon Taffeta w/ PU coating	–	DAC Featherlight
	Vario 23	4 lbs 5 oz	32 ft ²	54" x 84"	2	6 ft ² + 6 ft ²	41"	3	2	2	Siliconized Nylon w/ PU coating	Nylon Taffeta w/ PU coating	–	DAC Featherlight
	Dyad 22	3 lbs 1 oz	26 ft ²	51" x 75"	1	4.5 ft ²	42"	2	1	2	Siliconized Nylon w/ PU coating	Nylon Taffeta w/ PU coating	–	DAC Featherlight
	Solo 12	2 lbs 8 oz	18 ft ²	35" x 84"	1	3 ft ²	35"	2	1	1	Siliconized Nylon w/ PU coating	Nylon Taffeta w/ PU coating	–	DAC Featherlight

Figure 28a. The North Face Tent Chart based on the product specifications of each tent. The tents not highlight in blue have been eliminated as it is either too heavy or too large.

THE NORTH FACE TENT CHART														
	Name	Total Weight	Floor Area	Floor Dimensions	Vestibules	Vestibule Area	Peak Height	# of Poles	Doors	Sleeping Capacity	Fabric			Technology
											Canopy	Floor	Fly	
Base Camp	Double Headed Toad 44	8 lbs 11 oz	53.7 ft ²	90" x 92"	2	15.7 ft ² + 15.7 ft ²	50"	2	2	4	Nylon Ripstop	Nylon Taffeta w/ PU coating	Nylon Ripstop w/ PU coating	DAC Featherlight
	Flying Frog 33	7 lbs 10 oz	44.75 ft ²	72.5" x 89"	2	7.3 ft ² + 7.3 ft ²	45.5"	2	2	3	Nylon Ripstop	Nylon Taffeta w/ PU coating	Polyester Ripstop w/ PU coating	DAC Featherlight
	Roadrunner 33	7 lbs 4 oz	43.3 ft ²	70" x 89"	2	9.3 ft ² + 9.3 ft ²	45"	2	2	3	Nylon Ripstop	Nylon Taffeta w/ PU coating	Polyester Ripstop w/ PU coating	DAC Featherlight
	Rock 32	6 lbs 7 oz	43.3 ft ²	70" x 89"	2	4.6 ft ² + 4.6 ft ²	45"	2	2	3	Nylon Ripstop	Nylon Taffeta w/ PU coating	Nylon Ripstop w/ PU coating	DAC Featherlight
	Big Fat Frog 24	6 lbs 7 oz	30.8 ft ²	50.5" x 90.5"	1	14.3 ft ²	42.5"	2	1	2	Nylon Ripstop	Nylon Taffeta w/ PU coating	Polyester Ripstop w/ PU coating	DAC Featherlight
	Roadrunner 23	6 lbs 8 oz	33.6 ft ²	54" x 89"	2	9.3 ft ² + 9.3 ft ²	42.5"	2	2	2	Nylon Ripstop	Nylon Taffeta w/ PU coating	Polyester Ripstop w/ PU coating	DAC Featherlight
	Tadpole 23	5 lbs 7 oz	26.2 ft ²	50.5" x 85.5"	1	9.15 ft ²	41"	2	1	2	Nylon Ripstop	Nylon Taffeta w/ PU coating	Nylon Ripstop w/ PU coating	DAC Featherlight
	Rock 22	5 lbs 11 oz	33.6 ft ²	54" x 89"	2	4.7 ft ² + 4.7 ft ²	42.5"	2	2	2	Nylon Ripstop	Nylon Taffeta w/ PU coating	Nylon Ripstop w/ PU coating	DAC Featherlight
	Quartz 22	5 lbs 1 oz	33.6 ft ²	54" x 89"	2	4.3 ft ² + 4.3 ft ²	41"	2	2	2	Nylon Ripstop	Nylon Taffeta w/ PU coating	Nylon Ripstop w/ PU coating	DAC Featherlight
Trailhead	Trailhead 8 Bx	21 lbs 7 oz	122.7ft ²	206" x 104"	2	25 ft ² + 25 ft ²	75"	4+1	2	8	Nylon Taffeta	Nylon Taffeta w/ PU coating	Polyester Taffeta w/ PU coating	Fusion Pitch
	Trailhead 6 Bx	18 lbs 4 oz	92.7 ft ²	148" x 104"	2	23.2 ft ² + 23.3 ft ²	72"	4+1	2	6	Nylon Taffeta	Nylon Taffeta w/ PU coating	Polyester Taffeta w/ PU coating	Fusion Pitch
	Foundation 6	16 lbs 10 oz	79 ft ²	115" x 98"	1	14 ft ²	72.5"	4	2	6	Nylon Taffeta	Nylon Taffeta w/ PU coating	Polyester Taffeta w/ PU coating	Fusion Pitch
	Foundation 4	14 lbs 11 oz	60 ft ²	93" x 93"	1	11 ft ²	64"	4	2	4	Nylon Taffeta	Nylon Taffeta w/ PU coating	Polyester Taffeta w/ PU coating	Fusion Pitch
Recreational	Mountain Manor 8	24 lbs 5 oz	120 ft ²	184" x 97"	2	33.2 ft ² + 11.5 ft ²	74"	7	2	8	Nylon Taffeta	Nylon Oxford w/ PU coating	Polyester Taffeta w/ PU coating	Fusion Pitch
	Mountain Manor 6	20 lbs 11 oz	93 ft ²	143" x 97"	2	24 ft ² + 8 ft ²	74.5"	7	2	6	Nylon Taffeta	Nylon Oxford w/ PU coating	Polyester Taffeta w/ PU coating	Fusion Pitch
	Meadowland 6	13 lbs 7 oz	89 ft ²	135" x 98"	2	12.8 ft ² + 12.8 ft ²	56.5"	6	2	6	Nylon Taffeta	Nylon Oxford w/ PU coating	Polyester Taffeta w/ PU coating	-
	Meadowland 4	11 lbs 5 oz	56 ft ²	90" x 90"	2	15.6 ft ² + 15.6 ft ²	55"	6	2	4	Nylon Taffeta	Nylon Oxford w/ PU coating	Polyester Taffeta w/ PU coating	-
Modular	Docking Station	16 lbs 9 oz	97 ft ²	120" x 120"	0	0	81"	5	4	6	Nylon Taffeta	Nylon Oxford w/ PU coating	Polyester Taffeta w/ PU coating	Fusion Pitch
	2 Person Dock	2 lbs 9 oz	28 ft ²	84" x 50"	0	0	46.5"	1	1	2	Nylon Taffeta	Nylon Taffeta w/ PU coating	Polyester Taffeta w/ PU coating	Fusion Pitch
	4 Person Dock	4 lbs 4 oz	53 ft ²	92" x 90"	0	0	68"	1	1	4	Nylon Taffeta	Nylon Taffeta w/ PU coating	Polyester Taffeta w/ PU coating	Fusion Pitch

Figure 28b. The North Face Tent Chart based on the product specifications of each tent. The tents not highlight in blue have been eliminated as it is either too heavy or too large.

smallest weight, this particular tent does not include a rain-fly; therefore the succeeding weight would be 4 lbs 1oz. Another factor to look into is sleeping capacity. As more people are designed to fit into a tent, more material is required, which equates into more weight. For tents that accommodate 2 persons the total weight is within the 5 lbs range, 3 persons is within the 6 lbs range and 4 persons is within the 7lbs and above range.

The floor areas vary with 26ft² being the smallest and 53.7ft² being the largest. This means that the square feet to person ratio is 15 sf/person. The smallest size ranks at 10sf/person and the largest size ranks at 17 sf/person. When translated in floor dimensions, the average size is 89" x 25" per person. The peak height varies between 36" and 50", with the average number being 43".

The vestibule, which is usually a floorless space that is created by assembling the rain-fly over the canopy, consists of one or two. The majority of the tents have two and the area varies between 4.3ft² and 15.7ft². It is assumed that the size of the vestibule is not premeditated and is instead a byproduct of the design of the rain-fly.

The amount of doors incorporated into the design fluctuates between one and two and there is no consistent pattern that gives reason to these results. The amount of poles used fluctuates between two and three. Results show that the Three-Season Core and Flight Series rely on three poles, whereas the Base camp uses only two. The poles are made of DAC Featherlite, which are original products to the North Face. "DAC Featherlite NSL aluminum tent poles were designed with two main objectives: to offer a high strength-to-weight ratio and to slide easily through tight pole sleeves typical of expedition tent construction. The result is an expedition tent pole that has an even higher strength-to-weight ratio than the original Featherlite™ pole, and one that works well with tent sleeve construction. This design includes an insert tube with a thinner wall than the main tube giving added strength to the sleeve joint. This construction detail eliminates excess weight and is balanced by a small strengthening tube at the joining position" (Product Technologies n.d.).

The fabric used for the canopy, floor and rain-fly are made of different materials and colors. Beginning with the canopy, The Flight Series tents are made of Siliconized Nylon with a Polyurethane Coating and the Three-Season Core and Base Camp are made of Nylon Ripstop. As proven by the total weight of the Flight Series tents, the use of Siliconized Nylon with a PU Coating is a lighter alternative to Nylon Ripstop. In addition to Silnylon being lightweight, Matt Heid of AMC Outdoors describes it as being

“extremely thin stuff, making it less resistant to puncture and abrasion. [However] this isn’t an issue for tents, where tear resistance - especially the ability to withstand strong winds without shredding - is the essential property” (Heid 2009). The floor for all of the tents is made of Nylon Taffeta with Polyurethane Coating. And the fly is made of Siliconized Nylon with a Polyurethane Coating for the Three-Season Core and the Base Camp is either made with Nylon Ripstop with a Polyurethane Coating or Polyester Ripstop with a Polyurethane Coating. Between Nylon and Polyester, “Polyester fabrics withstand exposure to ultraviolet rays better than nylon tents and are the best choice for long term campsites [and] Nylon tents are generally lighter in weight” (Tulin n.d.).

Organizing the product specifications of the North Face tents have uncovered useful information that will aid the basic design components of the proposed prototype. With this information a base point for the dimensions and materials will be found, however it will not drive the design of the prototype. Instead it will be data to reference and observe for inspiration.

3.23 Product Design Conclusion

Submerging into the wealth of knowledge that Patagonia and the North Face has invested into their products has brought about an interesting set of information. By researching two outdoor companies that have different specialties, a greater understanding of basic wearable architecture design components has been achieved. The fabric technology of Patagonia along with the tent specifications of the North Face are corresponding collections of data that when viewed as individuals are mere explanations, however when the two are combined it has the ability to produce an exceptional prototype.

The information learned on fabric technology has revealed that Patagonia offers a number of materials that are suitable for all types of weather, environments and activities. It is argued that by using Patagonia’s fabric along with the product measurements of the North Face, an outstanding prototype can be built. For instance, the Capilene polyester fabrics that are coated with Durable Water Repellant can be used for the floor and canopy and the waterproof H2No fabrics can be used for the rain-fly. This suggestion would be appropriate as Capilene polyester is a lightweight and soft fabric that provides sun protection, however when it rains the H2No rain-fly can provide protection from the rain. When transformed into a garment, the Capilene fabrics can serve as the baselayer and the H2No fabrics can be the outershell.

In addition to the materials suggested, the research conducted on the North Face also produced suggestions on the dimensions of a tent. Based on the information gathered, the average amount of floor area per person is 15sf. Thus, when translated into floor dimensions, the average size is 89" x 25" per person. And the average peak height per tent is 43".

The data collected on branded products has initiated the starting point for the design of the proposed prototype. A vast amount of information has been discovered and it will be a great reference in the design phase. With the information uncovered by these two brands a durable, timeless and high performance prototype will be created.

3.3 Survival Tools

"As contemporary societies have become more mobile, a dramatic increase in the number of tools available to support the new forms of nomadism has occurred" (Kronenburg, Lim and Chii, *Transportable Environments 2* 2003, 16). These tools are designed with the benefits of convenience, durability and dependability. All of these survival products are suitable for almost any emergency situation and thus become of great use when forced into situations without modern conveniences. The intention of these products are to help maximize a person's chances of survival and to be of assistance when advanced technologies are not present.

Basically all these tools create a survival kit, which "is a distillation of the most-effective and simple means of staying alive" (Lundin 2003, 119). While each kit is uniquely supplied with items to meet the needs of individuals there are common features that each share. Generally, survival kits are prepared "to be relevant to the environment encountered, lightweight and portable, waterproof, durable and dependable, complementary to the physical fitness and expertise levels of the user, able to meet a wide variety of conditions, comprised of multiple-use components, [and] panic-proofed [with] components that can be utilized if you are injured and simple" (Lundin 2003, 123). It is comprised of quality commercial products that can be purchased in stores, through catalogs or online. Each product acts as its own entity and can be simply stored away in a pocket or storage space.

In order to keep research applicable to the proposed prototype, the following survival tools have been analyzed: Inflate-a-Potty, All Weather Hooded Thermal Blanket, Light Stick Green 12-Hour, Radio Flashlight Cell Phone Charger and Life Straw. These

products were chosen based on the data collected in Chapter 1, which revealed the needs of natural disaster victims, and Chapter 2, which uncovered the needs of people on a daily basis. In this phase of the project, tests have not been conducted to determine the quality of each survival tool. Thus, the following comments are based on speculation and the success of each product will be realized in the design phase of the project.

3.31 Inflate-a-Potty



Figure 29. Inflatable and portable toilet that can fit into a pouch when deflated.

Inflate-a-Potty is an inflatable and portable sanitary toilet solution. It is designed to inflate in a matter of seconds and uses disposable bags as liners. When it is not inflated, it can be folded up to fit into a 7"W x 8.5"H x 2"D pouch.

This product becomes extremely handy in situations where facilities are unhygienic or unavailable, like that of circumstances after a natural disaster. Its ease of assembly and compact features are also beneficial to the users as there is no struggle and hassle while being used or carried around. The maximum weight capacity of the Inflate-a-Potty is unknown and thus, a recommendation would be to incorporate a portable toilet that can withstand a decent weight capacity of possibly 250 pounds. In addition, it should be designed to be used in a private setting.

3.32 All Weather Hooded Thermal Survival Blanket



Figure 30. Thermal Survival Blanket that can be compactly folded.

The All Weather Hooded Thermal Survival Blanket is a 5'-0" x 6'-0" blanket with a hood. It weighs about 10 ounces and can be compactly folded up to fit in small storage spaces. According to its product description, "this blanket will reflect and help retain over 80% of radiated body heat, providing warmth and protection, even in subzero temperatures. [It has] a four ply laminate of clear polyethylene film, a precise vacuum deposition of

pure aluminum, a special reinforcing fabric [called Astrolar] and a layer of colored polyethylene film.”

The All Weather Hooded Thermal Survival Blanket has a wide range of uses. While its ultimate use is a blanket, it also can be an emergency signal or rain poncho. Its versatile qualities are convenient with the ability to reduce to pocket-size through folding and later open up at full-size to provide an entire body wrap around protection. With its four ply laminate it creates a durable and waterproof material that is resistant to tearing and penetration. This lightweight blanket is a great solution and replacement for a typical blanket as blankets are more bulky, heavy and large. In addition, it is safe from water, easy to carry from place to place and keeps individuals warm.

3.33 Light Stick Green 12-Hour



Figure 31. Light Stick: source of light that does not require electricity and is instead generated upon bending.

Lightstick is a stick that upon bending will generate at least 12 hours of lighting. Unlike other lighting devices it is not powered by electricity and does not require batteries, which is quite fitting for

disaster situations. It has a shelf life of up to four years and can be used in a variety of ways. Applications that the Lightstick can be used as include a flashlight, lantern and night time lighting tool.

Lightstick is a very light and inexpensive device that weights about 1.5 pounds and cost less than \$2.00. It has many conveniences, and is easy to use and transport anywhere. This tool typically replaces the function of a lantern and should be used at night to light the desired area of the prototype, whether it is inside or outside of the shelter. It is unknown how bright of a light it produces, which prompts a suggestion to test out this tool before incorporating it into the design. One constraint of this tool is that once it is bent to initiate the light, the light does not turn off until it is dead and thus it is meant to be used for long uses and not short.

3.34 Radio Flashlight Cell Phone Charger

The American Red Cross FR-150 is a self-powered and solar-powered radio, flashlight and cell phone charger all in one. It does not require any electricity or batteries; instead it operates with the power of hand cranks or the sun's energy, which make it constantly rechargeable and reliable. In addition, it has an optional AC power



Figure 32. Radio Flashlight Cell Phone Charger

supply. It has an AM, FM and NOAA Weather Band tuners.

The American Red Cross FR-150 has the skill of being one tool with a multi-use of functions. It provides multiple modes of communication that are of remarkable aid when there is no electricity or in emergency situations. It has the ability to tune into AM and FM tuners for news broadcast, leisure and public service announcements and also NOAA Weather Band for “weather forecasts, alerts and other emergency messages.” Another mode of communication is the bright white 3-LED flashlight that allows for signaling help to others and simply providing light when dark. Lastly, it can recharge cell phones using the charging cord; however this feature is a little tricky as the charging cord is “available by returning the included card and specifying your phone’s model.” Thus, unless this step is carried out prior to an emergency or disaster situation, a cell phone will not be able to be recharged.

3.35 LifeStraw



Figure 33. Lifestraw.

“LifeStraw is a portable water purifier that effectively removes all bacteria and viruses responsible for causing common diarrhoeal diseases. LifeStraw requires no electrical power or spare parts and can be carried around for easy access to safe and clean water. [It is easy to use as the only instructional step is to] place the LifeStraw in the water and sip through the mouthpiece”. It can filter up to 700 liters of water, which is about 2958 cups of water.

LifeStraw is a remarkable product that highly increases the availability of clean water when contaminated water is present. As research on the effects of natural

disasters has proven clean water is vulnerable to becoming scarce and as a result individuals either deplete their source of supply or are forced to wait for assistance from others. With this device, individuals will not have to worry about thirsting for clean water.

3.36 Survival Tools Conclusion

The survival gears analyzed are simple solutions that are lightweight, portable, and capable of replacing some of life's daily conveniences. These practical tools can aid natural disaster victims with their problems as they do not rely on the grid and are independent of modern technologies. In the event that the design of the garment/shelter does not entirely meet the needs of the users, these devices will suffice.

3.4 Current Technologies Conclusion

Prior to researching Wearable Architecture, Branded Products and Survival Tools, there were many design questions that existed, however this study has answered most if not all. The thorough analysis of garments and retailed products has resulted in a base of knowledge that will spearhead the design of the prototype. Each bit of information collected will in some way, shape or form affect the final outcome of the prototype. To further explain, the criterion used to analyze each example of Wearable Architecture has resulted in a complete list of opportunities and constraints that will direct the features incorporated into the design. In addition to this, the product specifications of the branded products have provided solid numbers to work with. As the study of existing technologies has been completed, the next phase can be executed and thus, the culmination of this data will result in a wearable disaster relief kit.

Chapter 4

Research Summary

As the research methodologies have been completed, the previously stated hypothesis is recapped: wearable architecture can inform a new direction in temporary disaster relief for the families of Hawai'i. The goal of this thesis is to create a prototype for a wearable disaster relief kit. This article of clothing will be able to stretch beyond its conventional use and become an immediate tool for suffering people. With its transformative features it will have the skill to adapt to fluctuating environments and thus provide a multi-functional space for victims. While collecting data there were discoveries that supported this idea. For instance, the events that followed the recent American Samoa earthquake and tsunami reinforced the potential of this project. Secondly, the popular use of tents following a disaster maintains the notion that it is a viable solution when nature challenges the strength of buildings.

The research found on the recovery efforts practiced by the survivors of the American Samoa earthquake & tsunami supports the idea that the prototype will be of great use during natural disasters. For instance, yurts and Jumpstart to Recovery kits were distributed by the American Red Cross as they "learned that getting tangible items into the hands of disaster victims soon after a disaster is widely appreciated and quickly gets people on the road to recovery. [This was] the first time such a resource [had] been distributed by the Red Cross [and the idea stemmed from] research conducted by the American Red Cross in April 2009 with prior disaster victims. [This study] shed some light on what disaster victims needed in the wake of devastation [and] they said their critical needs [included] clear information about the disaster situation and available relief and recovery resources" (Chawla 2009). The information gathered was taken very seriously by the American Red Cross, and thus it led to the creation and distribution of the yurts and recovery kits. This kit has similar intentions to those of the wearable

disaster relief kit in this thesis. Also, the procedures and steps taken to execute the Jumpstart kit are also quite similar, the only downside is that it is not passed out immediately after a natural disaster. So while the job done by the American Red Cross is a leap in the solutions to disaster relief, it still has some constraints.

Another supporting idea is the prevalent use and dependency of tents and portable shelters that occurred after Hurricane Iniki, Hurricane Katrina and the American Samoa earthquake and tsunami. As the use of yurts has already been explained, focus will concentrate on Hurricane Iniki and Hurricane Katrina. The use of tents was very popular among the people of Kaua'i and it proved to be an efficient temporary shelter for disaster victims. "It is estimated that about 6,000 people on Kauai were rendered homeless by Hurricane Iniki, with many of these people occupying shelters and tents for several weeks after the storm" (Chiu, et al. 1995, 92). According to Jan TenBruggencate of *The Advertiser* Kaua'i Bureau, "a fair proportion of the island had been forced to resort to some form of camping out." Some residents lived in tents on the lawn of their destroyed homes rather than leaving their Kaua'i properties and neighbors (Borg, et al. 1992, 38, 48). A report by the Federal Emergency Management Agency shows that as of October 26, 1992 FEMA provided 4,100 tents and 7,500 cots (Federal Emergency Management Agency 1992, 32). Based on the data collected, tents were heavily used by survivors of Hurricane Iniki. As for Hurricane Katrina, the use of tents was mild because victims were able to transport to other shelters on the mainland United States.

According to Ruth Slavid, "the tent is usually either a basic structure in which to rough it, or a high-tech solution for people in extreme environments, [however] it has another and darker use. One of the sights following any disaster, natural or man-made, is the sea of tents that springs up to house refugees" (Slavid 2007, 93). Seeing that the use of tents and portable shelters is a popular necessity in the aftermath of a disaster, specially designed wearable shelters that are adequately equipped and able to switch into a tent can be appropriate for disaster situations. These transformable garments will be an upgrade from using a conventional tent and will be ergonomically built to meet the needs of survivors.

Tents often provide shelter but are not fully equipped with supplies and necessities to cater to a victim's needs. In order to design an effective wearable disaster relief kit, a basic understanding of the daily needs of people and the needs of disaster victims is required. Thus, alongside the study of natural disasters, a study was undertaken on minimalist shelters, which included indigenous shelters, low-income

housing, and homeless dwellers. These investigations revealed the essential items that are crucial to life survival:

Daily Needs

- Shelter
- Food
- Water
- Warmth
- Comfort
- Protection from the Elements
- Privacy
- Storage
- Safety
- Hygiene
- Laundromat Services
- Communication
- Companionship
- Entertainment

Disaster Related Needs

- Shelter
- Food
- Water
- Information on how to cope
- Ice
- Floating Device
- Storage
- Transportation
- Package
- Lighting device
- Generators
- Medicine
- Batteries
- Toilet Paper
- Medical Assistance
- Radio
- Can Opener

The items listed above are common tangibles and intangibles that people utilize in the event of a disaster as well as on a regular basis. This set of needs influences the design decisions and helps to develop effective survival tool. It is not guaranteed that all of these needs will be incorporated into the design of the prototype, however all will be considered and only those that are truly crucial will be integrated.

In addition to understanding the needs of people, their way of life was also studied. In general, the study on minimalist shelters revealed many surprising ideas that are impractical to apply to the proposed prototype. Nonetheless, there are still some noteworthy features that are worth duplicating. In most cases, the idea behind cultural practice is meant to be copied, and not the original construction. Below is a list of

recommended traits from indigenous shelters and homeless dwellers that can be considered in the prototype construction, and a short description that shows why it is beneficial. In parenthesis is the group that practices these qualities. For further information the previous sections should be referred to.

- Hearth (Bushmen, BaMbuti, Plains Indians, Kirgizian, and Masai) A fire is not only used by the indigenous tribes, but by the urban person as well. It is a great way to control the climate when your shelter is unable to.
- Expansion (BaMbuti and Mesakin Quisar). This is a great characteristic because when the shelter gets too small, it can continue to grow and thus, accommodate large groups.
- Sharing (Bushmen). In the event of a disaster, the act of sharing and giving are measures that help the recovery process run more smoothly. Of course, it isn't the best solution to rely on others for help nor is it always possible to give to others, however when possible it should be practiced.
- Simple (Plains Indians, Inuits, Kirgizian, and Bedouin). With a fairly straightforward design, the construction of a shelter becomes relatively easy to construct. It takes about an hour to pitch the shelter and less than an hour to take apart. The shape and form of the dwelling is basic, yet it offers maximum structural stability.
- Portable (Inuits, Plains Indians, Kirgiz, and Bedouin). The material of their dwellings is easily packed and brought over to a new settlement with the use of either a travois or animal. It is of great benefit to be able to travel with the materials because the groups do not need to rely on the forthcoming environment.
- Movable skin (Plains Indians, Kirgizian, and Bedouin). The role of additional skin is rather simple, yet well thought out and quite effective in adapting to the winter and summer weather. This method of developing a movable skin is definitely worth duplicating because even though Hawaii generally has a tropical climate, there are changes in temperature as well.
- Privacy (Kirgizian and Bedouin). Curtains were used to attain privacy between the spaces of men and women; however disaster victims will not utilize curtains with this same intent. Instead, this method will be practiced in order to achieve a sense of retreat for families and individuals.

- Safety (Bedouin and Homeless Shelters). In addition to carrying weapons, the Bedouins were very cautious of strangers approaching a shelter other than from the front. A sense of safety should be provided as this will allow survivors to concentrate on other important issues.
- Site Specific (All). Inhabitants have designed and organized tents to cater to specific environmental conditions. It is crucial to take the location and natural surroundings into consideration when designing as this will enable an appropriate prototype.
- Multi-functional (Plains Indians, Kirgizian, and Street Dwellers). The ability to incorporate multiple uses for one object is an essential quality that the prototype should embody. This helps to conserve space and limit the amount of materials being carried.
- Comfort (BaMbuti, Inuit, Plains Indians, Kirgizian, Masai, Navaho, Mesakin Quisar, Homeless Shelter, Tent Dweller and Street Dweller). It is important to feel at ease while wearing and/or inhabiting the prototype. In addition, it is advantageous to possess a comfort object for reason that it is uplifting and can increase a victim's mental and emotional well-being.

Interestingly, prior to this investigation it was believed that the lifestyle of indigenous groups and homeless dwellers would present more applicable features than what has been found. Although the list shown above reveals a lot, the list of inapplicable methods that have not been mentioned and can be found in Chapter 2 is much longer. In any case, even though an indigenous and homeless lifestyle may not be entirely applicable to the proposed prototype, their lifestyle shed some light on issues that need to be addressed.

Research on the current technologies of today followed the minimalist shelters investigation. In order to gain knowledge on the technologies of urban nomads, a study that concentrated on the sophisticated inventions of today was conducted. To help keep the research applicable, wearable architecture, branded materials, survival tools and advanced materials were analyzed to concentrate on existing technologies that are similar and relevant to the proposed prototype.

The wearable architecture artists analyzed include Takehiko Sanada (designer of Prefab Coat), Kotsuke Tsumura (designer of Final Home Jacket), Justin Gargasz (designer of Vessel) and Lucy Orta (designer of Connector Mobile Village). The work of

these artists is not exclusively designed to address the concerns associated with disaster relief, however each design has a feature or two that could aid a victim. The Prefab Coat is an inspiring precedent because it can expand into a larger shelter by zipping two garments together. This expansion mechanism allows for groups of people to gather and spend the night away from home together. The Final Home Jacket is not the type of wearable architecture that the prototype will develop into, however the 44 pockets that can be used to stock survival rations is a clever approach to storage. Vessel is a well thought out garment that can transform into four different modes: a jacket, reversible jacket, sling bag and tent. Its multifunctional characteristics do not set it apart from the other precedents studied, however its sleek transformation from a jacket to a sling bag in order to accommodate the body's temperature is. The Connector Mobile Village is distinctive for its use of materials that are specially designed to support and respond to the surrounding environment that could either be cold or hot.

As each design was qualitatively analyzed, focus shifted to being quantitative and the topics evaluated included versatility, construction, transportation, materials, ventilation, lighting, storage and expansion. Beginning with versatility, each garment made it clear that the prototype must be flexible and easily manipulated in order to respond to the needs of the user. And in an effort to support the shelter's versatility, all models must be transported by wearing it to destinations. The materials and construction of the four models vary showing that there are multiple ways that a shelter can be erected. However, common hardware that is used by most is zippers and poles. Common fabrics include those that have durable and resilient properties. For the three garments that transform into a shelter, the space is lighted with natural lighting instead of artificial lighting and a type of ventilation system is provided. Among all models, it was not common to incorporate storage space for users and only half incorporated an expansion option. Although comfort was not included in the chart, it is important. As each precedent was not physically explored it is impossible to rate the level of comfort in each model. Instead speculations were made and it is assumed that the one person tents of the Prefab Coats, Vessel and Connector Mobile Village are uncomfortable as it is a tight space. While Orta has developed a carbon structural armature to address the claustrophobia of the user, it still does not suffice for the limited movement of a user.

The outdoor gear companies Patagonia and the North Face were studied for examples of branded products. These items revealed an interesting set of variables. By researching the two outdoor companies that have different specialties, a greater

understanding of basic wearable architecture design components has been achieved. The information learned on fabric technology revealed that Patagonia offers a number of materials that are suitable for all types of weather, environments and activities. The product specifications of the North Face tents uncovered useful information that will aid the basic design components of the proposed prototype. With this information a base point for the dimensions and materials was found, however the information will not drive the design of the prototype. Instead it will be data to reference and observe for inspiration. By using Patagonia's fabric along with the product measurements of the North Face, an outstanding prototype can be built. The fabric technology of Patagonia along with the tent specifications of the North Face produces an exceptional prototype when combined.

The last area of focus was on survival gear, which becomes a survival kit when all tools are combined. Generally, a survival kit is prepared "to be relevant to the environment encountered, lightweight and portable, waterproof, durable and dependable, complementary to the physical fitness and expertise levels of the user, able to meet a wide variety of conditions, comprised of multiple-use components, [and] panic-proofed [with] components that can be utilized if you are injured and simple" (Lundin 2003, 123). It is comprised of quality commercial products that can be purchased in stores, through catalogs or online. Each product acts as its own entity and can be simply stored away in a pocket or storage space. In order to keep research applicable to the proposed prototype, the following survival tools have been analyzed: Inflate-a-Potty, All Weather Hooded Thermal Blanket, Light Stick Green 12-Hour, Radio Flashlight Cell Phone Charger and Life Straw. These tools are simple solutions that are lightweight, portable, and capable of replacing some of life's daily conveniences. These practical tools can aid natural disaster victims with their problems as they do not rely on the power distribution grid and are independent of modern technologies. When the design of the garment/shelter does not entirely meet the needs of the users, these devices will suffice.

With the completion of the research portion, the design phase can be executed. The collection of data on natural disasters, minimalist shelters, and today's current technologies will influence the design of the wearable disaster relief kit. By using the conclusions and supplemental data that was found in each topic, an effective prototype will be developed. Thus, the movement to provide wearable transformables to survivors is modestly progressing.

Chapter 5

Design Parameters

The accomplished collection of data on natural disasters, minimalist shelters and current technologies, marks the end of the research phase and the beginning of the design phase. As previously stated, the need for immediate post-disaster relief is increasing. Consequently, solutions are emerging from the field of fashion and while the demand for wearable architecture has been mildly explored by other artists, the solutions posed were not consistently geared towards disaster relief. To answer the latest requests on wearable architecture in relation to disaster relief, a prototype will be developed. The parameters of design are based on the composed charts and research discovered within the past chapters and thus, the following criteria is used:

5.1 Primary Components

Primary components are priority qualities that should be incorporated into the design. These traits are necessary in order to form a reliable and worthy design.

- Shelter: the article of clothing must transform into a reliable structure. The shelter will be designed to resemble the characteristics provided by a home. This includes stability, personal identity and space, storage for belongings, protection and privacy.
- Storage: the design must be equipped with multiple openings and pockets. This allows users to carry around valuable possessions and everyday survival items.
- Lightweight: the material must be light but not delicate. With the use of a fine

quality fabric, it will facilitate the movement of the user and be user-friendly.

- **Portable:** the prototype must be worn for ease of transportation. This convenient feature allows for the assembly and disassembly on almost any site and offers possibilities where permanent buildings would be unsuitable.
- **Protection from the elements:** the garment and structure must provide protection from cold, wind and moisture. It is essential to control these elements as a number of issues will arise. This includes heat blowing away from the user's body, valuables damaged by water, and moisture penetration throughout the shelter.
- **Durable:** the product must be made of high quality and a high tolerance for abuse. It is not disposable but instead recyclable and must offer long-lasting qualities that will withstand a number of uses.
- **Connection:** the prototype must have the ability to expand and join other prototypes in order to create a larger space. A typical kit will be suitable for one person and upon unification with other kits it will be able to host a group.
- **Comfort:** the functionality of the garment and tent must be ergonomically suitable. This elevates the well-being of survivors and soothes feelings of distress and concern.

5.2 Secondary Components

Secondary components are qualities that enhance the design, but are not entirely necessary.

- **Affordable:** offering an inexpensive survival kit will attract the community to invest in this prototype. Although there are many high-tech possibilities and expensive technologies that may be used in the design of the prototype, the price will be kept in mind, but will not dictate the design decisions.
- **Hygiene:** incorporating the use of hygienic commodities will alleviate some of the concerns associated with disasters.
- **Floating Device:** developing a buoy will provide a lifesaving mechanism that will keep users afloat and prevent drowning. This feature will be of great benefit in flooded situations or other water related disasters.

- Privacy: some level of seclusion should be available to users. Seeing that this prototype could be set up in the midst of a crowd, this will allow survivors to have their own physical space of retreat.
- Blanket: integrating a type of fabric cover offers users feelings of warmth and comfort. Similar to a comfort object, this can provide a psychological comfort that can help a victim during a transitional experience.

5.3 Survival Gear

In addition to the Primary and Secondary Components that will be integrated in the design of the prototype, here is a list of items that can be stored in the prototype. These items are relief resources that are intended to help a survivor to the road to recovery.

- Food: the ultimate necessity to survival. A 5 day supply of both ready-made and canned goods should be equipped in the prototype. Take note that certain canned goods need a can opener.
- Water Filter System: a portable tool that can treat water in all types of environments. This item is an important device in situations where clean water is unavailable.
- Combination Hand-Crank Radio Flashlight Cell Phone Charger: a quick solution to a power outage. This multi-functional unit does not rely on electricity and can cater to a number of needs, such as communication, lighting and entertainment.
- Toilet Paper: a common product that is associated with hygienic practices.
- Medicine: a collection of supplies, more commonly referred to as a First Aid Kit should always be carried. This will allow for immediate care of an illness and injury until a professional is present.

5.4 Summary

By establishing the limitations and structure of the design, the above components

will serve as a guide and offer direction for the design. Also, while the intention of these transformable fashions is to assist victims of natural disasters, it is recognized that these “garments have the potential for universal applications” (Kronenburg, Lim and Chii 2003, 17). As a result, while the design will be solely focused on addressing the needs of people in times of a natural disaster, it will still be applicable and useful in other daily situations.

Chapter 6

Design Process

The design of the prototype was influenced by the Design Parameters listed in Chapter 4 as well as the research gathered in Part I. Basically, the Design Parameters served as the program of the project and thus, it revealed specific issues that needed to be addressed in order to create an effective wearable disaster relief kit. As for the research conducted, it served as a guidance tool that was constantly referenced when making design decisions. In this chapter, the stages of the design are thoroughly explained with photos and descriptions.

6.1 Design Study

Before the full scale prototype was fabricated, a number of design studies were performed over a course of 3 months. These exercises have been documented and explained for the purpose of sharing the thought process that governed each study and helped to shape the final design. In an effort to thoroughly explain each study, a compilation of photos have been created, see Figures 34-39. These photos should be referenced while reading the accompanying text. Not only do these photos provide visual details that help to clarify the written descriptions, but it also communicates ideas that are not clearly stated.

6.11 Study 1: Figure 34

In the beginning of the design phase, it was believed that the best approach to developing wearable architecture was to modify the properties of an existing tent. This idea was highly influenced by the research conducted on branded products; more

specifically the North Face. From this study, it was learned that this company spends millions of dollars conducting research, performing tests, and understanding the properties of a tent. By doing so, the best line of tent products are manufactured and sold. With this in mind, it seemed impractical to design an original tent as the availability of resources was limited and the amount of data collected was incomparable to the knowledge of the North Face. Thus, this led to the decision of working with an existing tent and adapting it to become an example of wearable architecture.

A tent from the North Face was purchased and it consisted of two items, the Docking Station and the 2 Person Dock. These items were purchased because together they created a modular system, which fulfilled the Primary Component of connection. In Hawaii, the sizes of families are generally large, and so it was important to purchase a tent that had the ability to expand and accommodate a family. Basically, compared to the other components, connection played a strong role when deciding which tent to purchase. As for the other Primary Components of shelter, lightweight, portable, protection from the elements, durable, and comfort, it wasn't a strong concern because the research revealed that these were already elements that the tents embodied.

Upon arrival of the tent and after setting it up and experiencing the space, it was quickly decided that this method would not work out. Although it seemed like the best solution, it wasn't the right solution. Additionally, by using a ready-made tent that has been deemed the high-class of outerwear, it supposed that this solution was too luxurious for disaster victims. While sitting in the tent and observing its spatial qualities, it was recognized that the tent was too large for an individual. Interestingly, prior to purchasing the tent it was known that the Docking Station can accommodate 6 people and the 2 Person Dock can accommodate 2 people; however this information was overlooked because of its modular trait. Also, since there were intentions of modifying the tent, it was suggested that the seams be undone so that the individual pieces of the tent be designed for an individual and when all parts come together, then it would create a complete tent. Nonetheless, this idea was never executed for the reason that there were feelings of reluctance. The act of puncturing and damaging an expensive tent without absolutely knowing that this idea would work did not bring about confidence and more so, it began to solidify the notion that manipulating the North Face tent will not work.

6.12 Study 2: Figure 35

Quickly after deciding that the North Face tent will not perform and meet the requirements of this dissertation, the next design idea was studied. The overall thought of this stage was to design a simple tent that is modular and made of poles. It was decided that the best shape to work with is a triangle. Triangles are strong shapes with fixed angles that are designed in such a way that equally distributes forces throughout the structure. This shape is used in many tent designs and thus, it was almost intuitive to explore this form.

The immediate design response was to place two triangular frames at 7'-0" apart and cover it with fabric. The frame was made of poles and the base measured at 5'-0". The dimensions of this tent was chosen by briefly referencing the North Face Tent Chart, however there was a mistranslation and it resulted in a tent that was too large. Aside from the incorrect dimensions, there was a unique idea behind this tent. It was the transformation from a one person tent to a multi person tent. As shown in the top photo, this configuration with the 90 degree angle at the top was intended for an individual. In the event that additional space was needed, it was designed to rotate in a direction that would allow the base to become the hypotenuse, see bottom left photos. By doing this, another tent could be set up adjacent to its vertical side and thus, a larger tent would be provided. For even more space, additional tents can be set up by adjacently arranging the triangular frames next to each other and consequently, creating a tunnel.

As this was the first attempt to designing the prototype, it needed a lot more brain storming and it was suggested by my committee members that instead of using poles, an inflatable device should be used. This idea was brought up because compared to poles it is lightweight, has the ability to fold into a compact size and hasn't been heavily studied by previous tent designers. Another area that needed further development was the garment because at the moment there were no ideas of how this tent would transform into a garment. As a result, it was strongly recommended that the fashion aspect of this garment be equally explored with the architectural side.

6.13 Study 3: Figure 36

The next study model brought about significant design decisions that resulted in a parti diagram. This duo of model and sketches, initiated the basic concept of the wearable disaster relief kit and by working with this idea, it helped to produce the final model. The design of this study model began by borrowing elements from the previous

study, which included the use of a modular design with expandable abilities, and a triangular support system covered with fabric. The structure was made of an inflatable triangle and it had ropes lined over the frame to serve as supplemental support. In addition, there were two tubes, one at the top and another at the bottom, which connected the two walls to create a stable structure. Referring back to the photos found in the left column, the blue triangle represents the inflatable.

One of the main accomplishments of this study was determining the approximate dimensions of the prototype. Compared to the first reference that was based on the North Face Tent Chart, the second reference was taken more seriously. By using the chart alongside the average dimensions that were concluded on tents, it helped to establish suitable dimensions. The first established dimension was the peak height, which is 3'-0". According to the chart, the peak height varies between 3'-0" and 4'-2", with 3'-0" associated with one-person tents. Being that this prototype is intended for one person, it was decided that the peak height be 3'-0". Following this dimension was the size of the floor mat. Although the average floor dimension is 7'-5" x 2'-1", it was decided that 7'-5" is too long. Instead, a floor mat that could accommodate a 6'-0" tall person would suffice and thus, it was decided that 6'-0" x 2'-0" would be a comfortable size. At this point, these numbers were rough estimates that still needed to be tested out and further explored.

Following these established dimensions was the investigation of the inflatable structure's dimensions. Because this idea of working with an inflatable object was recently proposed, there was a lack of research and understanding on the properties of inflatable products. As a result, there was no base of knowledge to influence the size of the inflatable. By default, it was decided that the distance between the two walls be 2'-0" and this was a result of the size of the floor mat. In addition to the insufficient supporting data on inflatable structures, it was unknown how this object would be manufactured and if it was even possible. The prospect of finding a local inflatable manufacturer was impossible and with intentions of creating a full scale physical model, it seemed unfeasible to design a prototype made of an inflatable structure.

Another accomplishment that was met by this study was the primary component of connection. Unfortunately, the study model does not display how an individual tent can expand to become an encampment, however the idea was mentally developed and with the assembly of this study model, it provided a partial vision of the idea. Interestingly, it was thought that if two people had their own wearable disaster relief kit

that was set up parallel at 2'-0" apart, then it would create a space for three people. The third space would occur in the intermediate space that measured at 2'-0" apart. By going along with this idea, it supposed that one kit was required to provide enough fabric for an individual tent and the intermediate space that appeared when an additional kit was set up. This meant that 2 floors, 2 walls, and 2 roofs needed to be transformed into one garment.

This study model provided lasting design decisions that needed a few more tweaks before it satisfied and met the expected potential of the prototype. Similar to the last study, there were no fashion sketches or ideas. The one thought that consistently remained in mind was, the simpler the fabric design, the easier it would be to transform into a garment. This meant that by working with less organic shapes, such as triangles, rectangles, and squares, it would enable more straightforward transformations. The next area that needed attention was the technical details of how the pieces of the tent attached to each other in order to create a working system. In the study model, everything was held together by glue; however this method is impractical for the full size model.

6.14 Study 4 Figure 37

The parti diagram was built at a 1"=1'-0" scale, which was a rather small scale to progress with and thus, another model was built at a 3"=1'-0" scale. The goal of this study model was to address the Primary Components and finalize the dimensions of the tent. In addition to this physical model, there were design sketches of the garment.

Seeing that the basic concept of the prototype was decided, the next step was to incorporate the Primary Components. At this stage, lightweight, protection from the elements, durable and comfort were explored. It was believed that these components could be addressed by choosing appropriate materials. Based on the research collected on the North Face and Patagonia, Polyurethane Coated Ripstop is a popular fabric that is used for sportswear, and Polyurethane Coated Taffeta is commonly used for the floor of the North Face tents. As a result, it was determined that the floor would be made of PU Coated Taffeta and the canopy would be made of PU Coated Ripstop. It was a relatively instinctive decision as both of these materials meet the stated guidelines of being lightweight, water resistant, long-lasting and breathable. Additionally, these characteristics were beneficial properties that the garment should embody. Upon transforming the tent into a garment, the user is able to wear a durable fabric that is not

heavy and will keep the rain out.

Moving forward with the design of the floor, it was decided that the floor should be more than just a sheet of fabric. There was a desire to provide a cozy floorcovering that would bring comfort to the user. Instead of following the floor designs that are found in existing tents, it was agreed that fiberfill would be used. This would create a soft mat for survivors to sleep, sit and relax on.

Following this, was further investigation on the dimensions of the tent. It began with questioning if the floor dimensions were suitable. Originally, it was decided that 6'-0" x 2'-0" was acceptable, however after considering that a 6'-0" tall person needed to fit in the tent, it seemed more comfortable to extend the floor length by 6" and make it 6'-6" x 2'-0". This would permit a person lying down to have more area to maneuver in and not feel too constricted in the space.

The next dimensions discovered were for the triangular inflatable structure. This process was based on a guess and check method, yet to some extent the guessing phase was strategic. As previously determined, the peak height of the inflatable was 3'-0". Initially, a right triangle was drawn at this height; however that idea was eliminated because aesthetically it looked stiff, especially with the pointed corners. Consequently, there were two other directions to move in, which were to utilize either an obtuse triangle or an acute triangle. It was decided that an acute triangle would be more preferable because if an obtuse triangle were used, the base would roughly be the length of the floor mat. This was not desired because it would create a claustrophobic passageway that restricted inhabitants from moving between the adjacent interior spaces. With the use of an acute triangle, there was not too much modifying involved because although the appearance of the right triangle was not favored, it was not far off. In order to achieve a more aesthetically pleasing triangle, the 90° angle was replaced with an 80° angle and the pointed corners were replaced with rounded corners with a 2" radius. By using the confirmed information of a 3'-0" tall structure and an 80° angle, the remaining pieces of the triangle were methodologically determined with satisfaction.

This set of inflatable dimensions made up the two-dimensional portion of the structure and so, the three-dimensional portion still needed to be figured out. Particularly, these numbers were a result of guessing and its structural stability was later checked with an engineering consultant named Glenn Miyasato. It was decided that the thickness of each wall be 4" and the tubes that connected the two walls be 4" in diameter. The top tube gave a clearance of 2'-6" from the finished floor to the bottom of

the tube and the bottom tube had a minimum clearance of 2'-0" from the inner side to the edge of the wall, see drawing. While meeting with Glenn, he did not have any concerns about the selected dimensions, however he suggested that cross bracing was needed on the hypotenuse of the triangles. He also shared that typically an inflatable device is made up of a series of cells that are used to control the shape and prevent a large bulge that distorts the shape. For this reason, he felt that it was unnecessary to design an entirely inflated triangle. Instead the inner core of the triangle should be removed, which is identical to the composition of a raft. This meaning that the outer edges are inflated with a sheet of fabric in the middle.

Since the floor mat and inflatable structure's dimensions were determined, the next step was the canopy size. Based on the recently determined dimensions, the canopy needed to cover a width of 2'-8" and thus, 3'-0" was decided in order to provide some leeway. The length was determined by drawing the elevation of the floor and structure in AutoCAD, then drawing the canopy and making sure that it sufficiently covered the floor and structure. From here the perimeter was measured and it was 10'-0". Thus, the canopy dimensions were 10'-0" x 3'-0".

The last step of this study was the article of clothing. It was decided that the tent would transform into a jacket because it was believed that the garment should be worn over a victims outfit. In addition, a jacket is made of a significant amount of fabric, which is a valuable characteristic when considering the amount of tent fabric that needed to transform into a garment. Lastly, based on the research gathered on wearable architecture it was noticed that modifying and exploring the possibilities of a jacket was popular among many designers. With this in mind, it further influenced the decision of designing a jacket.

After spending a considerable amount of time thinking about the garment, there were finally some drawings to accompany those thoughts. Referring back to the sketch, the idea was to work with an existing jacket and attach additional pieces of fabric, which were the pieces of the tent. The blue piece represented the canopy, which was attached by looping it through a slit found along the back area. The green piece represented the floor, which was zippered to the bottom of the jacket. This piece had the ability to fold up and neatly button on to the underside of the jacket. It was designed in this manner in order to create a jacket that could adjust to the comfort level of the user. By elongating and folding the length, it allowed users to customize the jacket according to both wet and dry conditions. In the event of rain, the full-length jacket could be worn and if it were dry,

the short-length jacket could be worn. The drawback with this idea, which was pointed out by the committee, was that the pieces of the tent were attached to the garment instead of actually being the garment. It was suggested that the canopy and floor become the core of the jacket. Instead of taking a jacket and adding pieces to it, the jacket should be the canopy and floor. Another recommendation was to study a kimono because these Japanese outfits come in one size and are folded to fit all types of body sizes. Similar to the prototype, a kimono is made of a significant amount of fabric that must be strategically tucked and gathered in order to create this fitted and orderly look.

6.15 Study 5 Figure 38

This model was built at a 2"=1'-0" scale and the inspiration for this study model arose after realizing that the previous model failed to display how an individual tent developed into an encampment. While addressing this concern, it also focused on the suggestions that were offered by the committee. This included attaching cross bracing and creating a depression in the inflatable structure, and improving the tent's transformation into a jacket.

One of the main reasons for this exercise was to display how a group of individual tents developed into an encampment. As this was the first time that the idea was physically executed, an unforeseen concern arose. The floor mats were not exactly adjacent and had a 4" gap between each other. To remedy this problem it was decided that a portion of the width would stretch 8" in order to create flush floor mats.

The next step was to address the concerns associated with the inflatable. In order to provide cross bracing a set of hang tabs were attached to the hypotenuse of the triangle, see Figure 38b A. It was believed that ropes could be attached to these vinyl loops and thus reinforce the structural stability of the inflatable, see Figure 38a B. Following this was the removal and replacement of the triangle's inner core with a sheet of fabric. This approach created a niche in the wall and to some extent it was reminiscent of a function that is found in a home. Similar to a home that has recessed spaces that serve as display areas, drawers or counters, this inflatable structure created a place where items could be stored while set up as a tent. It was also thought that it could be a window; however the manufacturer had material limitations and did not offer clear vinyl. Consequently, the idea could be executed in the study model and not the full scale prototype.

The last concern that this study model addressed was the transformation from a tent to a garment. By taking the advice offered by the committee, which was to study the kimono, it influenced the design of the jacket. The main characteristic that was taken from this research was the folds that enabled a loose fabric to fit in a snug manner. Before exploring the folding style of the garment, a short exercise was conducted in order to understand the dimensions of a jacket worn by a 6'-0" tall person. It was found that the front and back side measured at roughly 2'-0".

While keeping the dimensions in mind, the pieces that needed to transform from a tent to a garment were considered. Being that one unit consisted of a one-person tent and the adjacent space, the jacket needed to accommodate 2 canopies and 2 floor mats. It was decided that since the canopy was thin, the 2 canopy fabrics could be layered together and transform into the back area of the jacket. Then, the 2 floor mats would become the right and left front panel of the jacket. After designating the location of the pieces, the folding system needed to be figured out. As a result, grid lines that were spaced at 1'-0" intervals were used. Using these grid lines, a series of folds were explored and a pattern was found, see drawing. For the canopy, the pattern works with every three spaces and basically, these spaces are folded into an "s". For the floor mat, the same method of grid lines at 1'-0" intervals were created. The folds were a lot more simpler as there was no pattern; instead the top and bottom were folded in such a way that matched the length of the back side.

After the folding mechanism was realized, my committee members commented that pockets should be built-in to the design. As a result, pockets were incorporated into the canopy and by doing so, it allowed for easy handing. This means that the transformation between the jacket and tent didn't affect the use of pockets; the supplies could simply be stored in the pockets and didn't have to be removed. As a jacket, the pockets neatly fit into the design of the back panel; and for the tent, the pockets draped over the inflatable structure.

6.16 Study 6 Figure 39

This model was assembled as if it were the actual model and thus, the pieces were sewn together and very little adhesive was used. By sewing the pieces of the prototype, there was one problem related to the folding system that arose: one panel was longer than the other side. This was simply a matter of restructuring the folds in the floor mat; and the changes can be seen in the final mode.

Another change made was on the inflatable structure. The connection detail on the hypotenuse was slightly changed in order to better support the design. This design was more suitable for the cross bracing as it embraced the diagonal reinforcements. In addition, this detail included another grommet that was used for the canopy. By stringing the rope through the grommet, the canopy was attached easily attached to the inflatable structure.

The last step of this study was designing the hood of the jacket. Basically, the hood was created by transforming the side walls of the tent. By folding each sidewall into three equal sections and then attaching each piece together, it created a hood.

6.2 Final Design

The prototype is named The Compleat Retreat due to its cunning pleating system that provides a safe place for survivors. The Compleat Retreat is an all-in-one shelter, jacket, floatation device and emergency kit. The shelter is a tent that is unveiled upon filling the inflatable device with air, and transforming the back and front panels of the jacket. This feature is utilized when a desired location is found; and in the event that travel is necessary the pieces are neatly deflated and folded into a jacket that is worn to the next site. The inflatable structure is not only the framework for the tent, but it also serves as a floatation device due to its buoyant qualities that are realized in water circumstances. The emergency kit is realized by storing survival gear and necessities in the pockets. It is recommended that a user equip the pockets with enough supplies to last 72 hours. For photos, see Figure 40.

The final design was made possible by considering the Primary and Secondary Components. Each component is recapped as a way to share how each of the needs have or have not been met.

Primary Components

- Shelter: the jacket transforms into a tent with an inflatable framework. The shelter provides stability, personal identity and space, storage for belongings, protection and privacy.
- Storage: a total of six 1'-0"x 2'-0" pockets are located on the canopy. This allows users to carry around valuable possessions and everyday survival items.

- **Lightweight:** the materials are made of 1.3oz Silicone Impregnated Ripstop and 1.9 Polyurethane Coated Ripstop. These materials are strong yet lightweight and waterproof.
- **Portable:** the prototype can be worn as a jacket for ease of transportation. This allows users to conveniently travel to almost any site and offer possibilities where permanent buildings would be unsuitable.
- **Protection from the Elements:** the selected materials along with the design provides protection from cold, wind and moisture.
- **Durable:** Seeing that Polyurethane Coated Ripstop Nylon has been used, the product is made of high quality and a high tolerance for abuse. These materials offer long-lasting qualities that will withstand a number of uses.
- **Connection:** the ability to expand an individual Compleat Retreat into an encampment was realized but not entirely executed. The connection details between the two units are unknown and with that realization, an encampment will be created.
- **Comfort:** the use of breathable and soft materials elevates the well-being of survivors and soothes feelings of distress and concern. Also, although the space is compact, it is not claustrophobic.

Secondary Components

- **Affordable:** currently the prototype is not affordable as it is considered a custom made unit. In the event that this product is made in bulk, it will be more affordable.
- **Hygiene:** has not been integrated into the design. Instead, hygienic related survival gear can be stored in the pockets.
- **Floating Device:** the inflatable structure that supports the tent design is also a floating device that can keep users afloat and prevent drowning. This feature is of great benefit in flooded situations or other water related disasters.
- **Privacy:** when utilized as a tent, the prototype provides seclusion. The side walls can be removed or attached according to the needs of the user.
- **Blanket:** the adjacent floor mat has a dual purpose as it can also serve as a blanket. This offers users the feelings of warmth and comfort.



Figure 34. Study 1 The North Face Tents (A) Exterior View of Docking Station and 2 Person Dock. (B) Tents packaged in compact sized bags. (C) Interior View with 2 Person Dock shown at left. (D) Docking Station draped over a 6'-0" tall person.

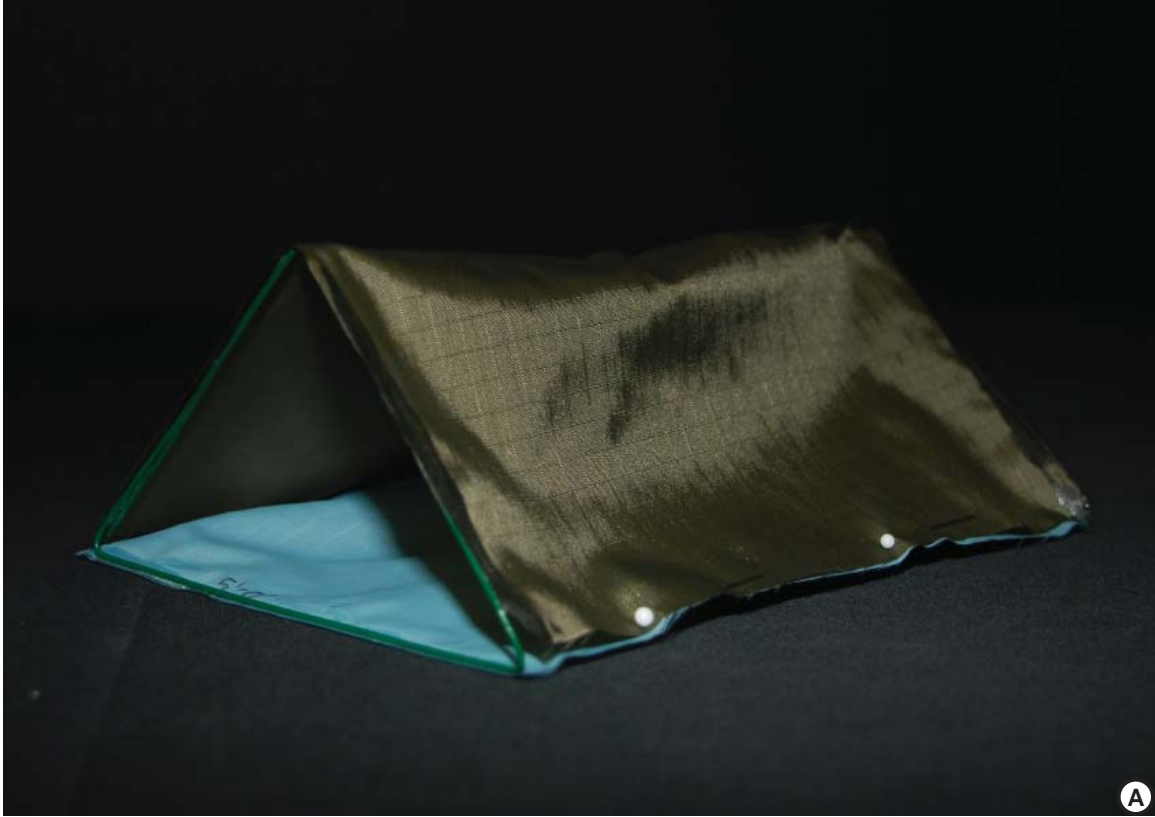

A

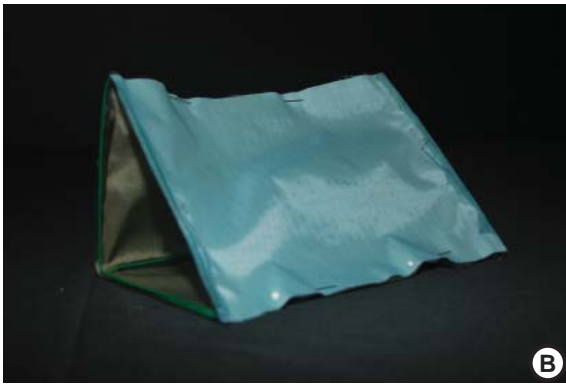

B

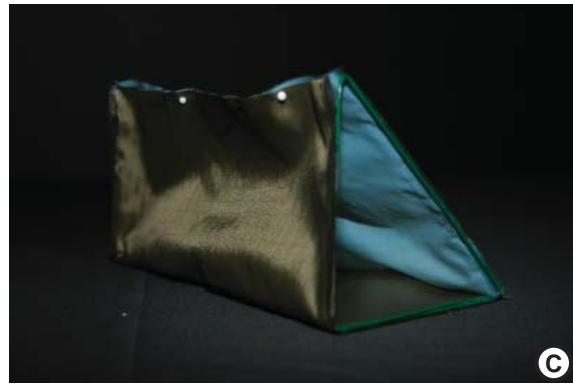

C



D

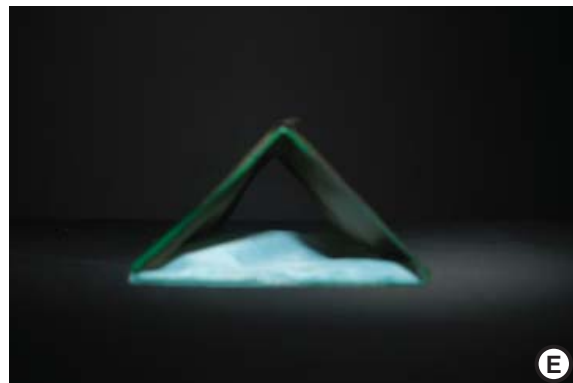

E

Figure 35. Study 2 Pole Construction (A) Tent set up for individual use. (B-C) Tent rotated to prepare for expansion feature. (D) Side Elevation. (E) Entrance.

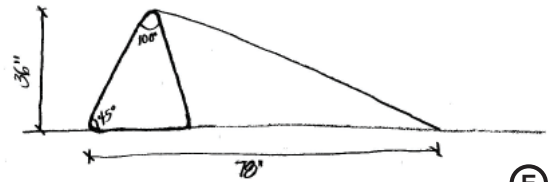
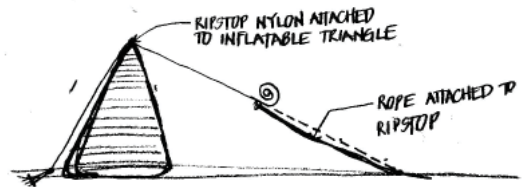
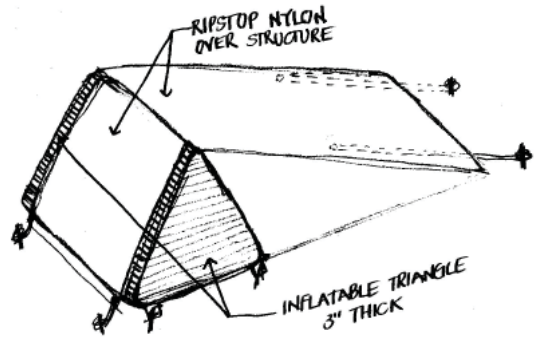
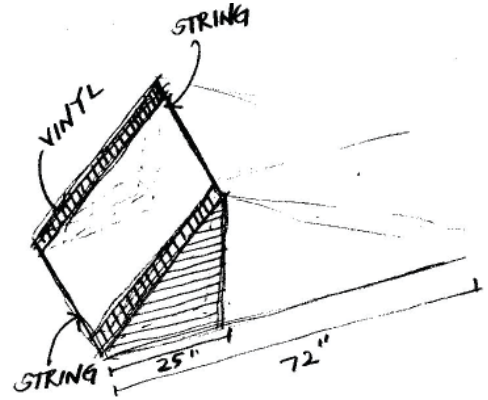
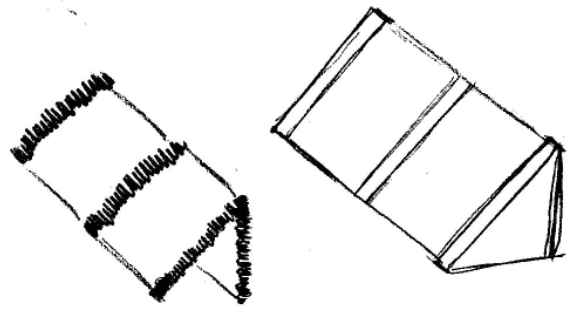
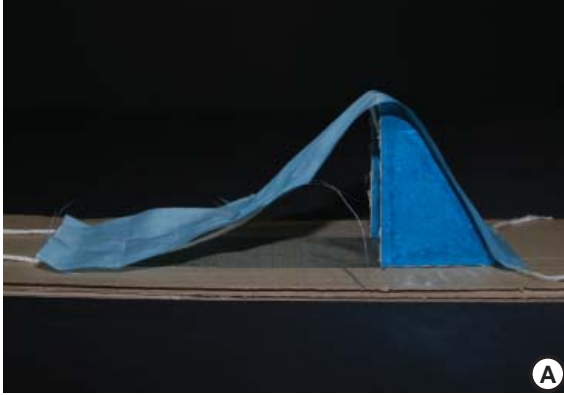
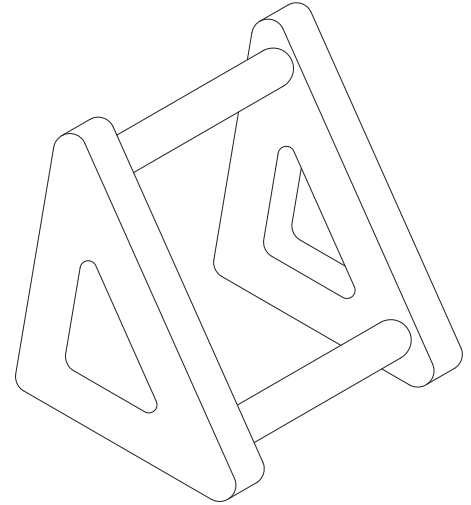
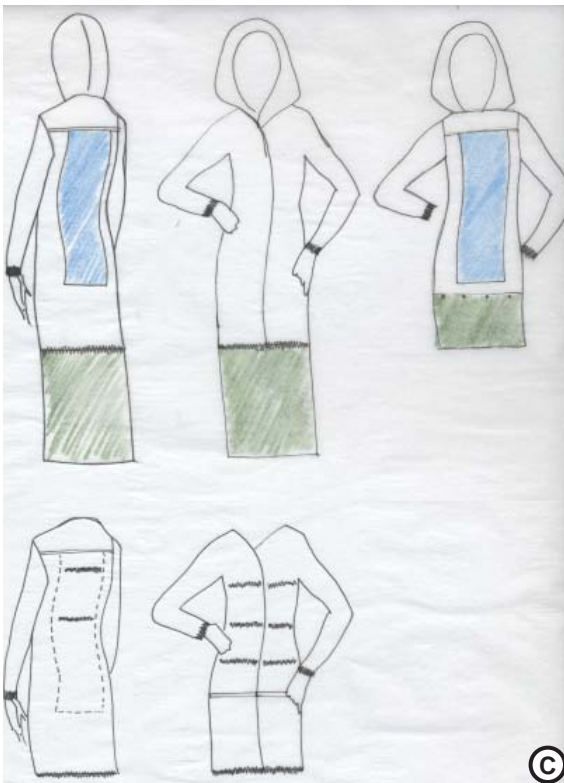
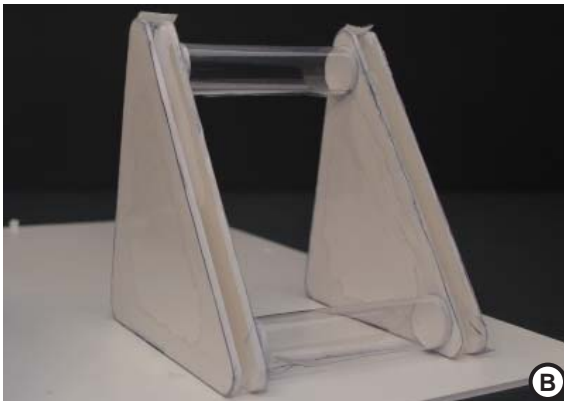
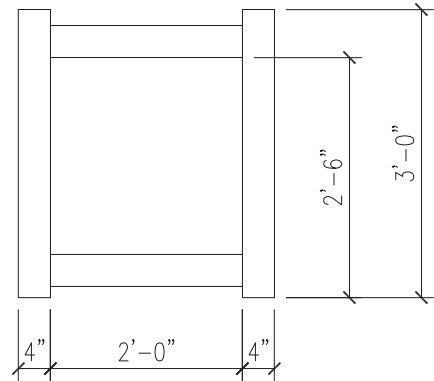

Figure 36. Study 3 Parti Diagram (A-D) Perspective Views. The idea of using an inflatable object as the structure was explored, thus the triangular shape represents air-filled structure. (E) Hand sketches.



Isometric View

Scale: Not to scale



Elevation

Scale: 1/2" = 1'-0"

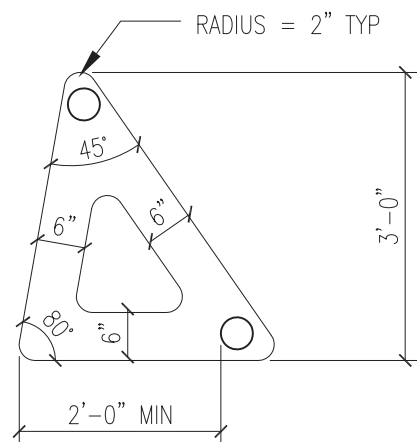

Section

Scale: 1/2" = 1'-0"

Figure 37. Study 4. (A) Refined and more accurate version of Study 3. (B) Inflatable structure with no depression. (C) Garment sketches showing how the pieces of the tent are attached to the jacket instead of being the jacket. (D) Dimensions of the inflatable device with the depression.

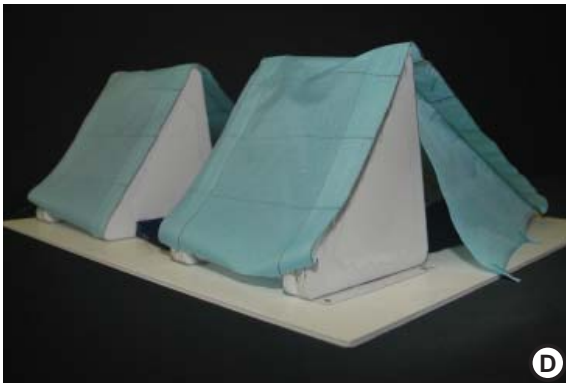
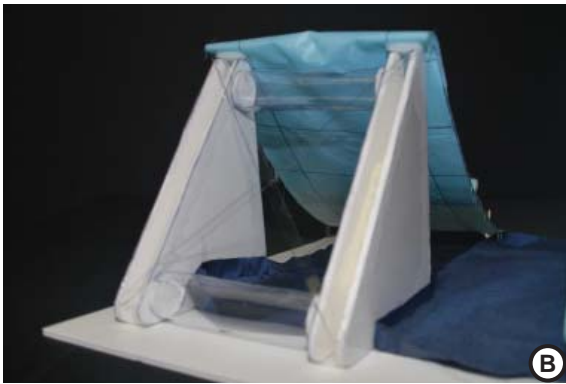

Figure 38a. Study 5 (A) Model at 2"=1'-0" displaying how an individual tent can expand into an encampment. (B) Cross bracing attached to the hypotenuse of the inflatable structure. (C-E) Exploration between a rope or pole secondary structure. Gridlines indicate where the fabric will be folded to transform into a garment.

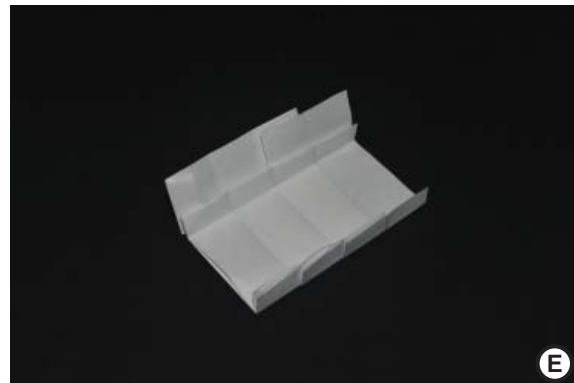
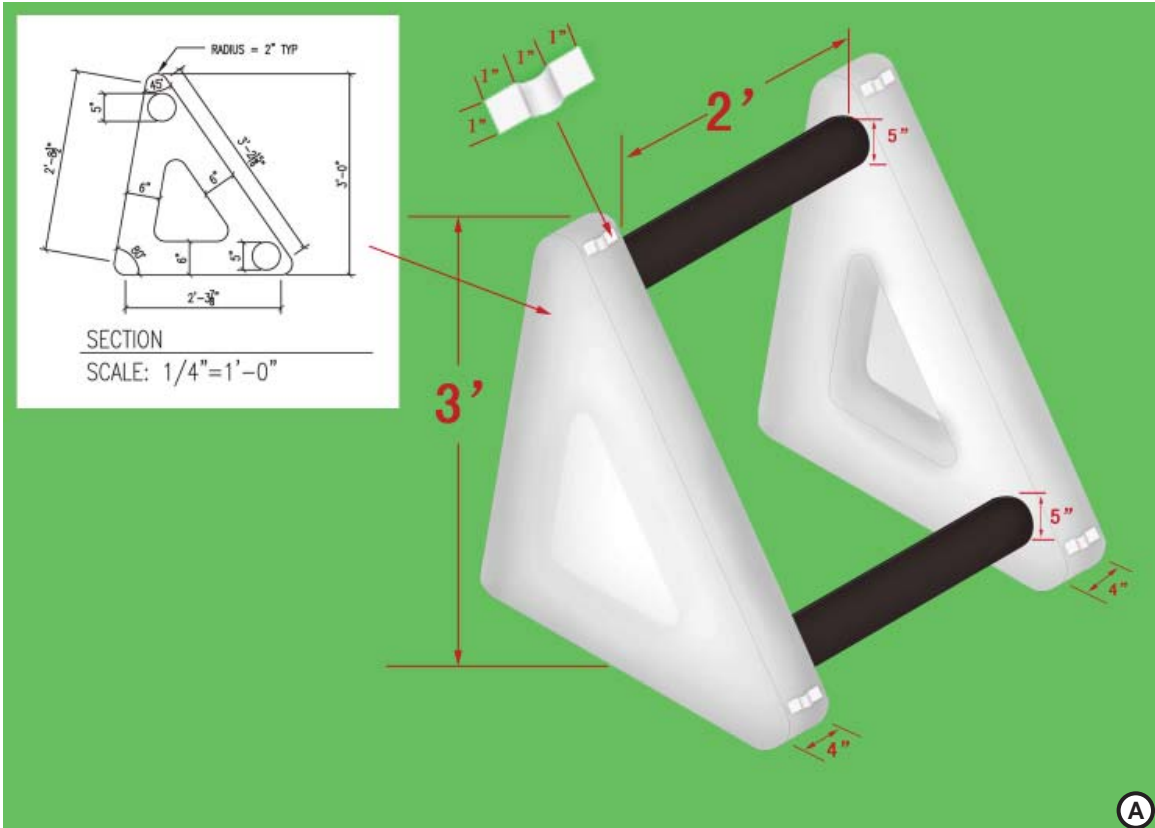

Figure 38b: Study 5 (A) Rendering completed by Jet Creations, Inc. showing the initial connection detail at the hypotenuse. (B-E) Paper exercises exploring how the tent fabric will transform into a garment.

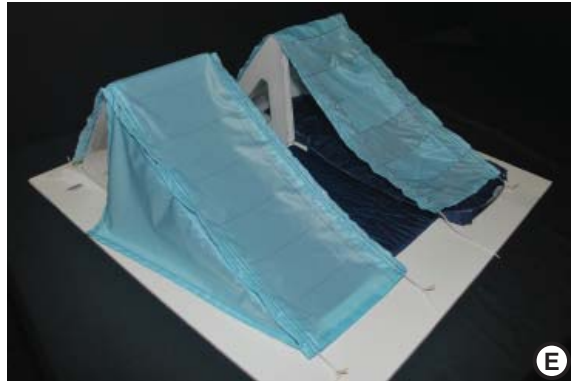
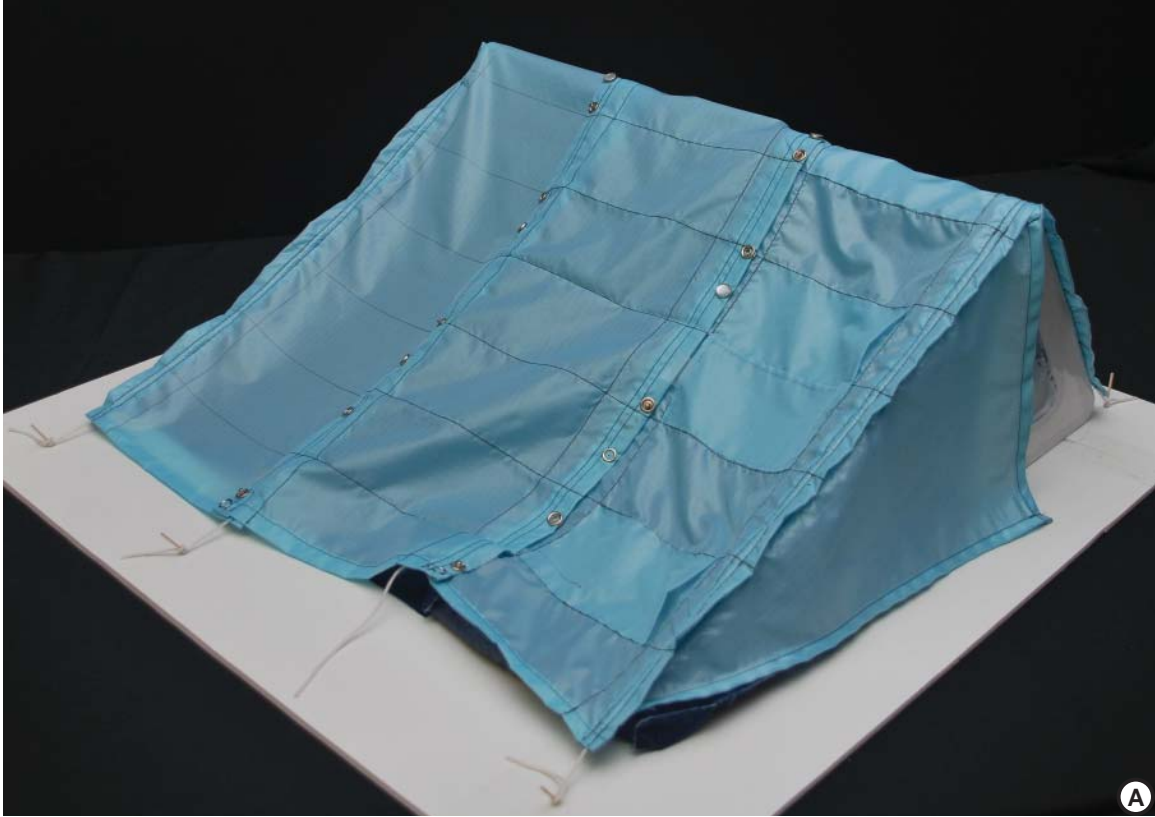
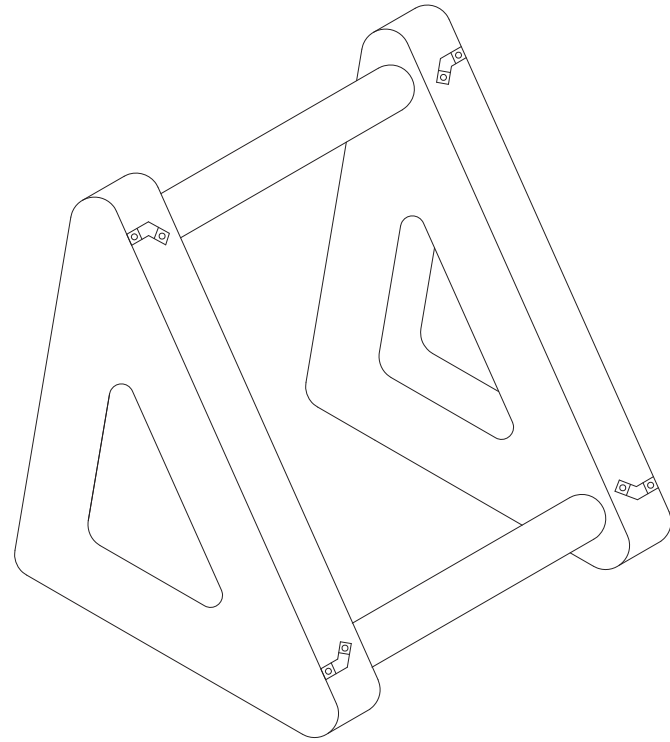

Figure 39a: Study 6 (A-E) Model at 3"=1'-0" showing the sewn tent material.



Figure 39b Study 6. (A) Pieces of the tent fabric folded into their unique garment component. (B) Tent canopy transforms into back panel of jacket. (C) Floor mat transforms into front right panel of jacket. (D) Floor mat/blanket transforms into front left panel of jacket. (E) Sidewalls transform into the jacket hood.



Isometric View
Scale: Not to scale

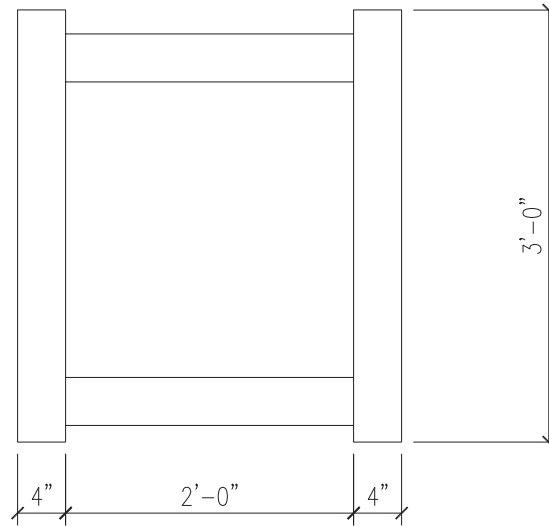

Elevation
Scale: 1/2"=1'-0"

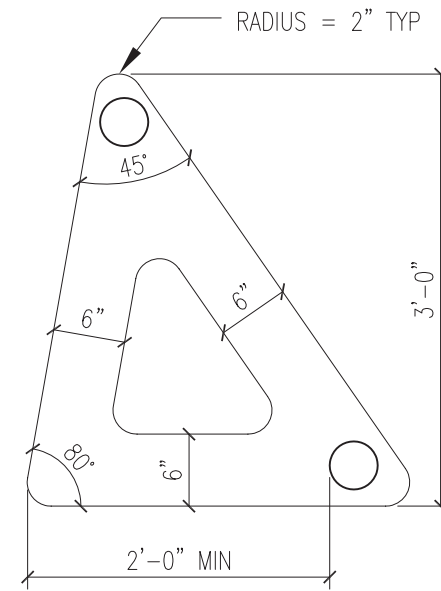

Section
Scale: 1/2"=1'-0"

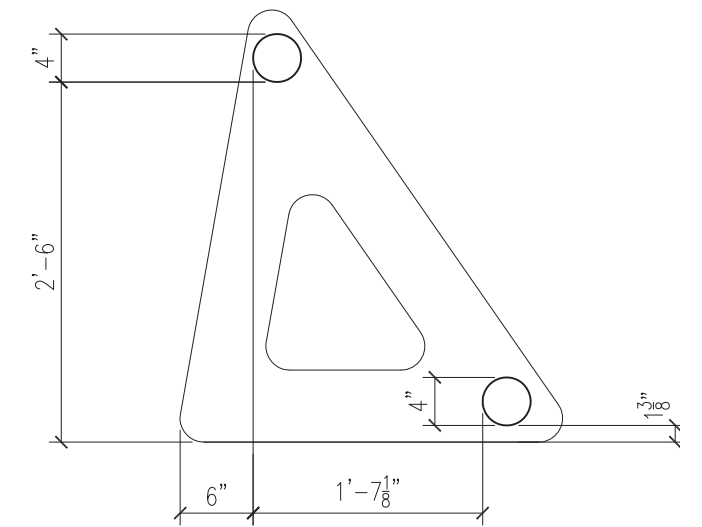

(A)



(B)

(C)

(D)

(E)

Figure 40a. The Compleat Retreat Prototype. (A) AutoCAD drawings of the inflatable structure. (B-E) Elevations of the inflatable structure.



Figure 40b. The Compleat Retreat Prototype. (A-D) Jacket shown with 3'-0" folding system.

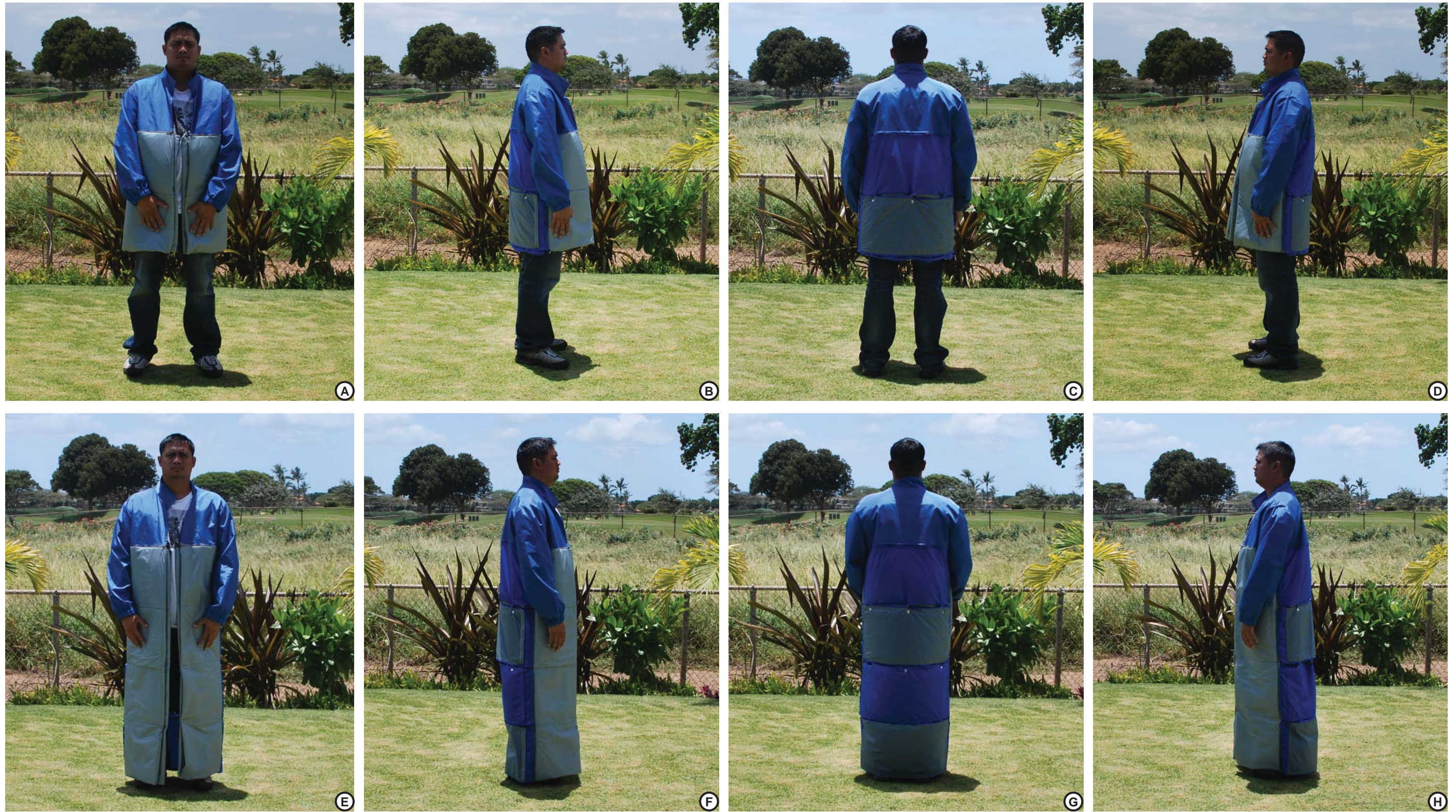

Figure 40c. The Compleat Retreat Prototype. (A-D) Jacket shown with 2'-0" folding system. (E-H) Jacket shown with 4'-0" folding system.



Figure 40d. The Compleat Retreat Prototype. (A-C) Jacket shown with hood. (D) Hood can be removed and unbuttoned to transform into the sidewalls of the tent.



Figure 40e. The Compleat Retreat Prototype. (A-C) Front left panel of jacket is unzipped and unfolded to transform into a floor mat. (D-F) Front right panel of jacket is unzipped and unfolded to transform into a floor mat or blanket.



Figure 40f. The Compleat Retreat Prototype. (A-E) Back side of jacket is unzipped and unbuttoned to transform into the canopy of the tent.



Figure 40g. The Compleat Retreat Prototype. (A-C) Floor mat and inflatable are staked down. (D-H) Rope is stringed through the grommets located on the inflatable and encasing found on the underside of the canopy.



Figure 40h. The Compleat Retreat Prototype. (A-E) Other side of canopy is stringed through with the rope. (F-H) Canopy is staked down.



Figure 40i. The Compleat Retreat Prototype. (A-D) Sidewalls are attached to underside of canopy. (E) Final design of The Compleat Retreat.



Figure 40j. The Compleat Retreat Prototype. (A & D) Interior view of tent. (B,C & E) Exterior view of tent.



Figure 40k. The Compleat Retreat Prototype. (A-D) Elevations of tent.

Chapter 7

Conclusion

7.1 General Conclusion

The purpose of the study was to discover whether the clothes and accessories worn by survivors of natural disasters in bicoastal cities can provide shelter and relief to survivors between the event and the supply of government issued temporary housing. Such discovery has been executed and it is believed that The Compleat Retreat has the potential to prompt a new movement in wearable architecture for disaster relief. The benefits of wearable architecture are many and although the prototype has not been tested in a real disaster, there is great confidence in its potentials. The success of The Compleat Retreat is due to the strategic design approach that has been practiced. By carefully analyzing the information gathered on natural disasters, minimalist shelters, and today's current technologies, an effective list of design parameters was developed.

The case studies sought improved the objective and creation of the prototype. By studying the problems that are associated with natural disasters, it enhanced the understanding of different needs that victims experience in the event of a disaster. Likewise, the research on minimalist shelters, which include indigenous shelters, low-income housing, and homeless dwellers, provided information on the needs of people but with more insight on defining day-to-day needs. Additionally, this study developed awareness on prospective survival methods that groups practice. The last investigation, which focused on current technologies, initiated a base of knowledge on product specifications. As the research question examines fashion and architecture in order to assess if the emerging urban nomad fashion trend can inform a new direction in temporary disaster relief for the families of Hawai'i, the specific topics studied provide essential information that identifies issues that need to be addressed. Without this

collection of data, the design of the prototype would be insignificant and thus, the benefits of wearable architecture would be trivial. Nonetheless, the gathered research was strongly taken into consideration and the primary concern of solving the shortcomings of architecture when a disaster strikes was answered.

In addition to benefiting the lives of disaster victims, The Compleat Retreat has the capacity to be used in other universal applications. Due to its simplicity and integration into an everyday article of clothing, it is easy to wear anywhere. Whether going to the beach, park or wilderness, or even taking an aimless stroll, this wearable transformable can be effortlessly worn, taken off, and set up at any desired location. Users can stop and relax at any given site without worrying about a place of refuge. Plus, it has pockets that allow a number of survival or entertainment supplies to be stored away.

Relating The Compleat Retreat back to an emergency situation, the wearable transformable is essentially a survival kit. It is an all-in-one shelter, jacket, floatation device and emergency kit. The shelter is a tent that is unveiled upon filling the inflatable device with air, and transforming the back and front panels of the jacket. This feature is utilized when a desired location is found; and in the event that travel is necessary the pieces are neatly deflated and folded into a jacket that is worn to the next site. The inflatable structure is not only the framework for the tent, but it also serves as a floatation device due to its buoyant qualities that are realized in water circumstances. The emergency kit is realized by storing survival gear and necessities in the pockets. It is recommended that a user equip the pockets with enough supplies to last 72 hours.

The psychological benefits of a wearable disaster relief kit includes peace of mind and the mental note of having one less thing to worry about. Both of these advantages help to keep a person's stress level at a minimum, but most of all it gives survivors confidence. With this confidence, disaster victims are able to regain and maintain a positive attitude that increases a person's ability to survive. Often times it is believed that being mentally and emotionally strong impacts and almost determines whether a person will survive or not.

The physiological advantages of the prototype are just as important and it starts with its ability to provide the benefits of a permanent building and, eventually, a sense of home. The Compleat Retreat is an equipped shelter that has the talent to convert into a protective layer of clothing that provides a number of amenities. These amenities enable users to spend a few nights away from home and it includes multiple pockets to store

valuable possessions and survival items, comfortable materials that are lightweight and portable, and a reliable structure that protects users from the elements. The pockets are a convenient tool that functions as a survival kit. Included in these openings are the most important life sustaining gear, which include water, food, and a combination hand-crank radio flashlight and cell phone charger. Essentially, these tangibles are necessary for staying alive and considering that these items do not consume all of the pocket space, there is still room to include valuable possessions and objects of entertainment. The choice of material, which included ripstop and taffeta, for the wearable shelter is extremely appropriate for its function as it is a durable and breathable fabric that does not hinder the movement of the user. This high quality fabric has a high tolerance for abuse and can be recycled for future uses. Additionally, the ripstop and taffeta provides protection from the cold, wind, and moisture.

Another benefit is the potential to address and support the need to be mobile while keeping one's hands free. This hands free feature is very helpful as it allows people to function normally as well as to be of aid to others. For instance, it allows a parent to hold the hand of his or her child or to carry a bag filled with emergency supplies or everyday essentials.

Overall, The Compleat Retreat has reached an exceptional level of success. As this is the first prototype executed, there are many aspects that can be critiqued; however it is still a cohesive design that is well thought out. For instance, it has the potential to aid stranded victims who are unable to take refuge at a shelter due to road damage or overcrowding. Disaster survivors can set up camp adjacent to their properties and in remote areas. Additionally, people stuck in a flood zone can utilize the inflatable structure to stay afloat. For those who are rendered homeless, the jacket can transform into a tent and provide a place of refuge until the government takes action. Plus, with the multiple pockets, users can equip their Compleat Retreat with supplies so that they don't have to rely on other people.

7.2 Strength and Limitation of the Design

One of the most accomplished undertakings was turning fashion into a utilitarian discipline. Many people love fashions knack to deliver a sense of identity and self-expression. Also, with the many seasons of fashions, there is an array of new clothes that can be purchased and mix-matched to suit the needs of various personalities.

Ironically though, those same reasons of why fashion is loved are also the same reasons of why it is disliked. Reflecting on the purpose of fashion, it is an art with a deeper meaning of clothing a person's body and providing a layer of protection from various components. Today, that deeper meaning is overlooked and fashion has become a statement that represents a person's status and requires excessive shopping. So excessive, that many people are able to go for months without using the same clothes. Fashion is a frivolous field that does not cure the problems of the world, however with the development of The Compleat Retreat fashion is moving in a more productive direction. Its future is no longer vain as there is a rising potential to solve the problems associated with natural disasters. More so, this idea of wearable transformables is beginning to inform a new direction by providing shelter and relief to disaster survivors.

Another strength is The Compleat Retreat's multi-functional characteristics that include its transformation from a shelter, jacket, floatation device, and emergency kit. Favorably, these features are portable and can be easily transported. The wearable kit is extremely beneficial in disaster situations as it has the potential to provide assistance to victims and help them onto the road to recovery. Being that it has the capability to function as a tent, survivors are provided with an instant place of refuge. It is quick to erect and dismantle, and it can be assembled on almost any site. When utilized as a jacket, it is conveniently worn to the next site and with the multiple pockets that are found on the back, survival gear and necessities can be stored away to create an emergency kit. This feature is very handy because it gives people the opportunity to equip their kit with supplies that are often unavailable in the event of a disaster. The inflatable structure has a dual purpose and that includes functioning as the primary structure of the tent as well as a floatation device in water related disasters. It is quite advantageous to work with an inflatable structure because it is lightweight and compact, meaning that it can be deflated and stored away in a small space. Overall, The Compleat Retreat is lightweight, which makes it a convenient and trouble-free kit.

An additional benefit that is accomplished in The Compleat Retreat is its ability to cater to a person's climatic needs through its folding system. The use of pleats is very clever and it is essentially the driving force behind the design of the wearable transformable. These pleats are able to neatly fold into different lengths, which enables the jacket to meet the user's needs according to the current weather. For instance, on a warm day, the jacket can be worn at short-length with the pleats measuring at 2'-0"; and on a cool day, the jacket can be at full-length with the pleats measuring at 4'-0". In

addition, the jacket can also be worn at mid-length with the pleats measuring at 3'-0". This folding mechanism is rather inventive and although its purpose is purely function, it also comes across as being aesthetically pleasing. Users are able to have fun with the jacket and wear it in a variety of ways.

The next strength found in this project was the cohesive design of architecture and fashion. The Compleat Retreat succeeded in balancing and merging the two fields. As separate entities, both the tent and jacket can stand alone and represent their respective disciplines. In fact, the idea of the tent transforming into the jacket and vice versa, is completely put out of sight. Nonetheless, the two entities are capable of this transformation and the collaboration of both entities produced features and functions that influenced the final outcome of the design.

While there are many benefits to the design of The Compleat Retreat, there are a number of limitations that follow. The constraints were found upon execution of the full scale model and the solutions are preliminary ideas that need further research and study. The succeeding section discusses the constraints of the design as well as possible solutions to improve the wearable transformable.

7.3 Further Research

The next phase on the research topic of wearable architecture will focus on a number of design features that is aimed at advancing The Compleat Retreat. The following are ideas that will be refined:

7.3.1 Floor Mat

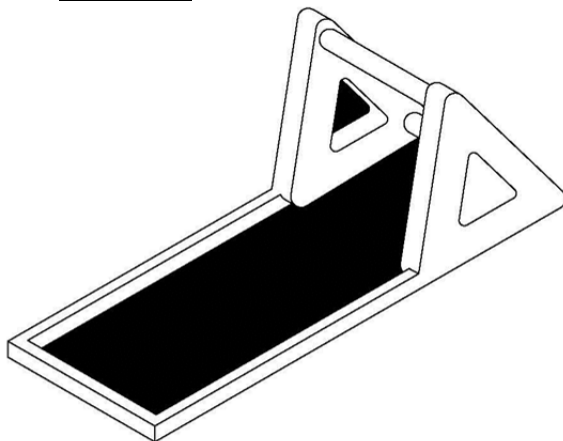

Figure 41. Inflatable Floor Mat

Constraint: Water issues

Currently the floor mat is made of Nylon Taffeta with Polyurethane Coating. This solution encounters water issues for the reason that the corners of the floor mat are not developed to prevent water from leaking in and the 4" high walls do not have a stable structure that averts the direction of the water.

The photo shown left, suggests that the floor mat be integrated into the design of the inflatable structure. The floor mat could be inflatable and thus, replace the current floor mats; or the floor mat could copy the design of a raft where only the perimeter is inflatable and the current floor mat is meant to fit into the middle space. This option could solve the current water related issues as well as improve the design of the floatation device.

7.32 Expansion

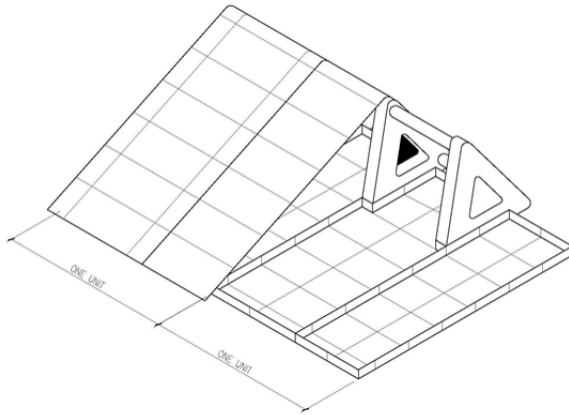

Figure 42. Expansion Feature

an encampment will be created.

Constraint: Expansion feature

The idea of expanding an individual Complete Retreat into an encampment was briefly explored, however it was not entirely executed. The overall design and concept of an encampment was recognized and thus, further analysis and designs should focus on the required hardware. The connection details between the two units are unknown and with that realization, an

7.33 Thin Cell Solar Membrane

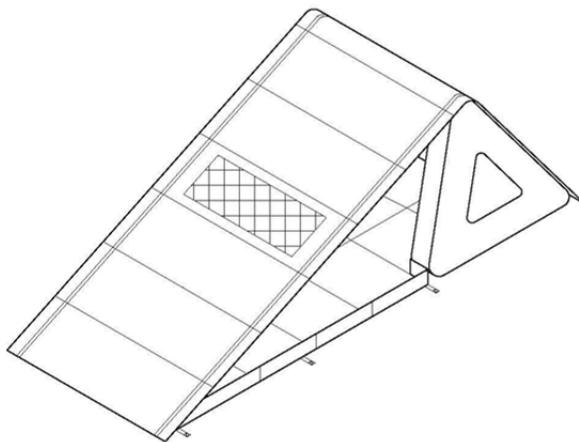

Figure 43. Exploration of thin cell solar membranes should be exercised.

Constraint: Lack of electricity

In each natural disaster studied, it was learned that electricity was disrupted and as a result, daily conveniences that relied on power were unavailable. In order to assist survivors, thin cell solar membranes should be incorporated into the design of the canopy. These devices are flexible and becoming more inexpensive. It is suggested that this feature focus on powering cell phone for

the reason that communication is essential to recovery.

7.34 Secondary Structure

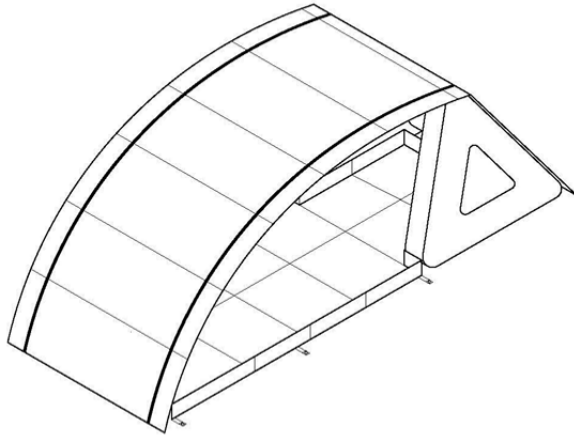

Figure 44. While the primary structure is the inflatable triangle, a secondary structure that is made of poles should be assessed.

frequently becomes weak. The use of a pole will create a more defined and solid structure that will offer more protection from exterior loads.

Constraint: Weak secondary structure

The primary structure of The Compleat Retreat is the inflatable triangle. This inflatable framework supports the fabric canopy that is anchored down by ropes. It is suggested that the ropes be replaced with a more stable structural system. Compared to a pole, a rope is weaker and it does not provide maximum air resistance. As a result, the canopy is constantly shifting and the rope tension

7.35 Hardware

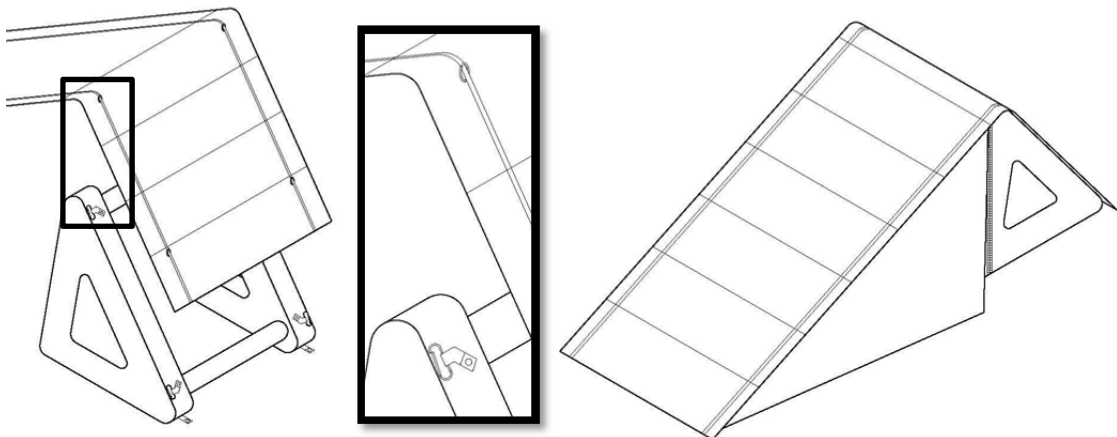

Figure 45. (Left & Middle) Grommet detail found at the hypotenuse should be replaced with new carabiner detail. (Right) New hardware should be added to the walls of the inflatable structure.

Constraint: Lack of efficient hardware system.

The hardware of the inflatable structure has a few details that can be modified. First, the hang tabs should be relocated in order to create a more stable structure. This new location will reinforce the foundation and prevent wind related uplifts. The second

modification is the grommet details located on the hypotenuse. It is supposed that a carabiner should be used instead of a grommet; and additionally a ring should be attached to the canopy. By doing so, the rope can be built-in to the design of the canopy and it will no longer be necessary to string the rope in and out through the encasing and the grommets. This will reduce the amount of steps that it takes to erect the tent and thus, result in a quicker set up time. The next revision is the addition of hardware onto the walls of the inflatable. The purpose of this hardware is to seal the fabric doors and create a more weathertight space. The last suggestion references the fasteners of the canopy, floor mat and side walls. These fasteners should be color coordinated in such a way that enables users to efficiently and intuitively snap them together into their organized system.

7.36 Shrug Lining

Constraint: Lack of interior lining affects warmth of shrug

The material of the shrug is made of 420 Denier Packcloth, which is a durable fabric that has excellent resistance to rot and mildew. Additionally, it has a polyurethane coating that makes it highly water repellent. One feature that this fabric does not provide is breathability and as a result, it feels a little uncomfortable while being worn. It is suggested that a type of lining be incorporated into the design of the shrug. This will allow the shrug to feel less muggy and more soft.

7.37 Backpack

Constraint: Climate control

The Compleat Retreat is a versatile product that is an all-in-one shelter, jacket, floatation device and emergency kit. While it already has multiple worthy functions, it is believed that it should transform into a backpack. The idea behind this transformation is to accommodate the unpredictable weather conditions. Currently, the jacket has the ability to fold at various lengths; however it should be able to fold away into a bag. This will provide a more comfortable journey on a hot day.

7.38 Color

Constraint: Aesthetic qualities overlook the functional benefits.

The role of color has been very small and its purpose was aesthetic rather than functional. For future applications, color should be used as both an aesthetic and

functional tool. It is suggested that a variety of color schemes be offered, and this option will promote self-expression as well as identity. Promoting identity through color is very important because it can help loved ones find each other. For instance, family members can coordinate a specific color scheme for their group with the intention of aiding and improving the search efforts that will occur in the event of a lost member.

7.39 Size

Constraint: One size fits all

One of the more concerned limitations is the size of the jacket. Currently, the jacket is only available in one size and as a result, it generally fits a 6'-0" tall person. Seeing that a natural disaster affects all types of people, a variety of sizes should be developed. These prototypes must fit children and young adults; and the design should be cohesive with the existing model.

7.4 Parallels of Architecture and Fashion

As The Compleat Retreat is faced with the next phase, there are a few thoughts that will be kept in mind for the next prototype and it is based on the parallels between fashion and architecture. This topic is very interesting and it was only at the design phase of this project that the similarities between the two were recognized and truly understood. The primary comparison was found in the construction methods of a building and a garment. The execution of both objects requires preparation that is often unnoticed and taken for granted. This is especially found when an object moves from the two-dimensional to a three-dimensional phase. For instance, a building is erected by following 2-D construction drawings that are basically the instructions for building a structure. These drawings indicate the individual pieces that when connected together create a finished structure. This same idea works for a garment; a pattern is purchased and this contains the sewing instructions and the 2-D individual pieces of the garment. When the pieces are all sewn together, it creates a finished product that is ready to be worn. Taking this idea of preparation a step further, whether sewing an article of clothing or fabricating a building there is a similar thought process that occurs and it is in regards to cleverly piecing together elements so that the finishing touch is achieved. When sewing a jacket the seams are usually hidden and in order to achieve that look the fabric must be sewn inside out. This gives it a clean and finished look that can also be

found in the construction of a building. Consider the hardware of a building, nails and joints are skillfully concealed to create this polished appearance that expresses this idea of being complete. In both architecture and fashion, the piecing together of members are cleverly attached in such a crafty and undisclosed way.

Another parallel between the two fields is the borrowing of techniques. In general it was found that folding techniques reflect the framework and designs of buildings. The most prominent exchange of ideas is the use of pleating, which is essentially the driving force behind the design of The Compleat Retreat. The use of pleats is very strategic and functional in the design of the jacket. The folds in the fabric not only act as the design of the garment, but it takes up the excess fabric that is needed for the tent. In addition, the sewn lines that are found throughout the fabric act as a guide for folding. Without these lines, it would be impossible to neatly fold up and transform the canopy into the jacket. While the pleats have a functional purpose for the jacket, the pleats are an aesthetic quality for the tent. The sewn lines become the decorative features of the tent and its location is basically a result of the pleats. This means that it is the location at which the fabric needs to be folded in order to carefully transform into a jacket. In essence, the functionality of the pleats influenced the graphic design of the tent.

The next similarity was based on the structure of the jacket and tent. Between both a building and garment, the material selection and design are elements that affect the structure. These elements work harmoniously to determine stability, flexibility and performance. Both objects have a responsibility of providing a type of framework that will support and reinforce the design. For instance, the shrug of the jacket acts as the primary structure that provides a framework for the remaining part of the garment. This particular article of clothing must support the supplemental pieces that transform from a jacket to a tent and vice versa; and this includes the ± 38 sf. of 1.3oz Silicone Impregnated Ripstop and ± 20 sf. of 1.9 Polyurethane Coated Ripstop. As for the tent, the inflatable triangle must support the canopy and in order to prevent deflating or structural failures, the material that drapes over must be lightweight. Consequently, 1.9 Polyurethane Coated Ripstop was chosen as it did not overpower the structure of the inflatable, but instead it complimented the design and provided enough protection from the elements. Between fashion and architecture, it is necessary to consider both the material and design in order to determine the structure. Without this set of knowledge, it is impossible to design a stable structure.

7.5 Personal Statement

Accomplishing The Compleat Retreat signifies the end of my educational career but the beginning of my life long study. Architecture as fashion and fashion as architecture will always be an intriguing topic to me and from this thesis, there are many lessons learned and reinvented thoughts that developed. Aside from the details that I learned on the relationship between architecture and fashion, there are more personal lessons that I will take with me. Primarily, I believe that project management is among the most important things that I learned. Throughout the course of this dissertation, I felt like I was the Project Manager, my Committee Members were my consultants, and Jet Creations was my supplier. Another lesson learned is my newfound appreciation for building construction. Being that I developed a full scale model, there was a lot of effort, thought and time taken to figure out how The Compleat Retreat would actually work. In my previous projects I built models at a smaller scale, so there were many construction details that were solved with glue. For this project, using glue wasn't an option as this was a real job that had to be realistic enough to be built.

Over the past 7 years, there are many things that I've learned but I don't quite recognize it because these things have become intuitive and almost like second nature. When I reflect back on the past semesters, I feel that my architectural wisdoms stem my experiences rather than specific assignments. For instance, assignments are exclusive to one project, whereas my experiences comprise of a variety. My experiences as a general concept consist of my involvements in numerous events. From these events, I have gained some type of knowledge or skill that was continuously being developed with more exposure to diverse tasks.

As I close this chapter, a new one will open and it is the start of my professional career. My beginning years will be aimed at becoming a licensed architect with inventive skills to design a safe and fun environment for my community. In addition to this, I'd like to continue my exploration on "Wearable Architecture: Fashion to the Rescue." I believe that the integration of architecture and fashion can bring about profound results that can improve this place that we call home.

Bibliography

- "American Samoa: A Long-term Recovery Operation." *Red Cross*. October 9, 2009. www.redcross.org (accessed 10 15, 2009)
- Ahu, Norman. "GTE Hawaiian Tel Update." *Iniki: September 11, 1992, Kauai, Hawaii, The Experience*, 1992: 63.
- American Society of Civil Engineers Hurricane Katrina External Review Panel. *The New Orleans Hurricane Protection System: What Went Wrong and Why*. Reston, Virginia: American Society of Civil Engineers, 2007.
- Borg, Jim, et al. *Hurricane Iniki*. Honolulu, Hawaii: The Honolulu Advertiser, 1992.
- Chawla, Maya. "American Red Cross Sends Recovery Kits to American Samoa." *American Red Cross*. October 06, 2009. www.redcross.org (accessed October 15, 2009).
- Chiu, Arthur N.L., Gregory L.F. Chiu, Charles H. Fletcher III, Hans-Jurgen Krock, J. Kenneth Mitchell, and Thomas A Schroeder. *Hurricane Iniki's Impact on Kauai. 1995*
- DePledge, Derrick. "American Samoans Try to Put Lives Back Together After Tsunami." *Honolulu Advertiser*. October 4, 2009. www.honoluluadvertiser.com (accessed October 21, 2009).
- Elsasser, Virginia Hencken. *Textiles: concepts and principles*. Fairchild Publications, Inc., 2005.
- "Fabric: Capilene® Polyester Baselayer." *Patagonia, Inc.* n.d. <http://www.patagonia.com> (accessed December 18, 2010).
- "Final Home." *Final Home*. n.d. www.finalhome.com (accessed November 24, 2010).
- Fox News*. September 29, 2009. <http://www.foxnews.com/slideshow/world/2009/09/29/tsunami-hits-american-samoa-massive-earthquake#slide=12> (accessed January 17, 2011).
- Freeman, Mike. *CBS Sports*. September 20, 2006. <http://www.cbssports.com> (accessed October 24, 2009)
- Gargas, Justin. "Vessel." *Core 77*. n.d. www.coroflot.com (accessed December 10, 2010).

- Heid, Matt. "Silicone Revolution?" *Appalachian Mountain Club*. August 2009. <http://www.outdooreyes.com> (accessed December 1, 2010).
- Iniki: September 11, 1992 Kauai, Hawaii The Experience*. "Federal Emergency Management Agency." 1992: 64.
- Iniki: September 11, 1992, Kauai, Hawaii The Experience*. "Salvation Army." 1992: 63.
- Iniki: September 11, 1992, Kauai, Hawaii The Experience*. "Joint Task Force Garden Isle." 1992: 63.
- Kronenburg, Robert. *Flexible Architecture that Responds to Change*. London: Laurence King Publishing, 2007.
- . *Transportable Environments Theory, Context, Design and Technology*. London: E & FN Spon, 1998.
- Kronenburg, Robert, Joseph Lim, and Wong Yunn Chii. *Transportable Environments 2*. London: Spon Press, 2003.
- Levinson, David, and Marcy Ross. *Homelessness Handbook*. Great Barrington, Massachusetts: Berkshire Publishing Group, 2007.
- Ludwig, Myles. *Kauai in the Eye of Iniki*. Hanalei Bay, Kauai: An Inter-Pacific Media Publication, 1992.
- Lundin, Cody. *98.6 Degrees: the Art of Keeping Your Ass Alive*. Layton, Utah: G. Smith, 2003.
- Mossman, Georgia. "Disaster brings death to Kaua'i." *The Garden Island*, October 2, 1992: 48.
- National Geographic: Inside Hurricane Katrina*. 2005.
- Nakaso, Dan. "American Samoa's Governor Copes with Disaster from Hawaii." *Honolulu Advertiser*. September 30, 2009. www.honoluluadvertiser.com (accessed October 21, 2009).
- Orta, Lucy. "Refuge Wear - Body Architecture - Urban Lifeguards." February 2006. http://thedesigndofprosperity.se/2006/press/orta/Refuge_Wear_Lucy_orta.pdf (accessed December 11, 2010).
- Pareja, Jessica Ann R. "City creates task force against street dwellers." *philSTAR*. December 4, 2010.

<http://www.philstar.com/Article.aspx?articleId=635991&publicationSubCategoryId=107> (accessed March 16, 2011).

"Product Technologies." *The North Face*. n.d. <http://www.thenorthface.com> (accessed December 18, 2010).

Quinn, Bradley. *The Fashion of Architecture*. Oxford, UK: Berg, 2003.

Ramirez, Tino. "KSSK's Perry and Price kept people aware of happenings." *Honolulu Star Bulletin*, September 12, 1992: 24.

"Samoa Earthquake and Tsunami of September 29, 2009." *Earthquake Engineering Research Institute*. January 2010. www.eeri.org (accessed January 14, 2011).

Schoenauer, Norbert. *6,000 Years of Housing*. New York, NY: W. W. Norton & Company, Inc., 2000.

Slavid, Ruth. *Micro Very Small Buildings*. London: Laurence King Publishing, 2007.

Snow, David A., and Leon Anderson. *Down on their Luck: a study of homeless street people*. Berkeley and Los Angeles, California: University of California Press, 1993.

"Technology: H2No® Waterproof Breathable Barrier." *Patagonia, Inc.* n.d. <http://www.patagonia.com> (accessed November 10, 2010).

Teige, Karel. *The Minimum Dwelling*. Cambridge, Massachusetts: The MIT Press, 2002.

The Garden Island. "Drivers Dodged." October 2, 1992: 48.

Topham, Sean. *Move House*. New York: Prestel, 2004.

Tulin, Philip. "How to Choose a Camping Tent." *Outdoor Eyes*. n.d. <http://www.outdooreyes.com> (accessed December 1, 2010).

Williams, Jean Calterone. *"A Roof Over My Head" Homeless Women and the Shelter Industry*. Boulder, Colorado: the University Press of Colorado, 2003.

Photo Credits

- Figure 1. Aerial view of Waimea, Hawai'i 5
Ludwig, Myles, *Kauai in the Eye of Iniki* (Hanalei Bay, Kauai: An Inter-Pacific Media Publication, 1992) 28-29.
- Figure 2. Hurricane Iniki Shelters 7
Photo Left:
Borg, Jim, et al, *Hurricane Iniki* (Honolulu, Hawaii: The Honolulu Advertiser, 1992), 52.
Photo Right:
Borg, Jim, et al, *Hurricane Iniki* (Honolulu, Hawaii: The Honolulu Advertiser, 1992), 49.
- Figure 3. Hurricane Iniki Damaged Roads 9
Photo Left:
Borg, Jim, et al, *Hurricane Iniki* (Honolulu, Hawaii: The Honolulu Advertiser, 1992), 81.
Photo Right:
Borg, Jim, et al, *Hurricane Iniki* (Honolulu, Hawaii: The Honolulu Advertiser, 1992), 56.
- Figure 4. Aerial View of New Orleans, LO. 11
American Society of Civil Engineers Hurricane Katrina External Review Panel. *The New Orleans Hurricane Protection System: What Went Wrong and Why*. Reston, Virginia: American Society of Civil Engineers, 2007, 31.
- Figure 5. Louisiana Superdome 12
Photo Left:
"BBC News | In pictures: The story of Hurricane Katrina, Superdome nightmare."
http://news.bbc.co.uk/2/shared/spl/hi/pop_ups/05/americas_the_story_of_hurricane_katrina/html/5.stm (accessed January 18, 2011)
Photo Right:
"BBC News | In pictures | Aid effort gathers pace."
http://news.bbc.co.uk/2/shared/spl/hi/pop_ups/05/americas_aid_effort_gathers_pace/html/5.stm (accessed January 18, 2011)
- Figure 6. Hurricane Katrina Housing Conditions 14
Photo Left:
"BBC News | In pictures | The exodus goes on."
http://news.bbc.co.uk/2/shared/spl/hi/pop_ups/05/americas_the_exodus_goes_on/html/6.stm. (accessed February 4, 2011)
Photo Right:

American Society of Civil Engineers Hurricane Katrina External Review Panel. *The New Orleans Hurricane Protection System: What Went Wrong and Why*. Reston, Virginia: American Society of Civil Engineers, 2007, 36.

Figure 7. Pago Pago, American Samoa 15
Associated Press. "Tsunami Hits American Samoa After Massive Earthquake." Fox News. <http://www.foxnews.com/slideshow/world/2009/09/29/tsunami-hits-american-samoa-massive-earthquake#slide=12> (accessed January 20, 2011)

Figure 8. American Red Cross Yurts and Jumpstart to Recovery Kits..... 16
Photo Left:
Howard, Bob. "American Samoa Tsunami 2009." Flickr.
<http://www.flickr.com/photos/americanredcross/3987406864/in/set-72157622497666858>. (accessed January 17, 2011)
Photo Right:
Dailey, Gene. "Disaster Relief Backpack 10.2.09." Flickr.
<http://www.flickr.com/photos/americanredcross/3977852113/>. (accessed January 17, 2011)

Figure 9. Natural Disaster Cause & Effect Chart 22
see Figure 1,4, and 7.

Figure 11a. Indigenous Shelters Chart 27
See Figure 12-13 for photo credits.

Figure 11b. Indigenous Shelters Chart 27
see Figure 14-16 for photo credits.

Figure 12. Ephemeral or Transient Dwellings..... 29
Photo Left:
"Bushmen Skerm". McGill University.
<http://www.arch.mcgill.ca/prof/schoenauer/arch528/lect01/ls01.jpg>.
(accessed October 29, 2009)
Photo Right:
"Pygmy Hut". McGill University.
<http://www.arch.mcgill.ca/prof/schoenauer/arch528/lect01/ls01.jpg>.
(accessed October 29, 2009)

Figure 13. Episodic or Irregular Temporary Dwellings..... 31
Photo Left:
"Inuit Tupiq, Summer Dwelling". McGill University.
<http://www.arch.mcgill.ca/prof/schoenauer/arch528/lect01/ls01.jpg>.
(accessed October 29, 2009)
Photo Right:

"Plains Indian Tepee". McGill University.
<http://www.arch.mcgill.ca/prof/schoenauer/arch528/lect01/ls01.jpg>. (accessed October 29, 2009)

Figure 14. Periodic or Regular Temporary Dwellings 34
Topham, Sean, *Move House* (New York: Prestel, 2004) 9-10.

Figure 15. Seasonal Dwellings. 38

Photo Left:

"Masai Hut". Flickr. http://www.flickr.com/photos/jeff_tanzania/3285664019/.
(accessed November 12, 2009)

Photo Right:

Staudt, Wolfgang. "Navajo Hogan". Flickr.

<http://www.flickr.com/photos/wolfgangstaudt/2212955750/>. (accessed November 12, 2009)

Figure 16. Semi-Permanent Dwellings..... 40

Myslilorski, Antoni. "Round Huts and the Cluster Arrangement – the Mesakin Quisar House". Tessler. <http://www.tslr.net/2007/12/round-huts-and-cluster-arrangement.html>. (accessed November 12, 2009)

Figure 18. Homeless Shelters..... 48

Photo Left & Right:

Walker, Richard. "Shelter gets reprieve". Starbulletin.

<http://archives.starbulletin.com/2008/05/05/news/story03.html>. (accessed October 29, 2008.)

Figure 19. Tent Dwellers 53

Marinas, Cherri. 11/10/2009.

Figure 20. Street Dwellers 55

Photo Left: Marinas, Cherri. 10/24/2009.

Photo Right: Marinas, Cherri. 11/5/2009.

Figure 21. Cart Dwellers..... 57

Photo Left: Marinas, Cherri. 11/5/2009.

Photo Right:

The Hawaii Independent Staff. "Carlisle makes life difficult for Honolulu's houseless by signing 'Pedestrian Use Zones' bill". The Hawaii Independent.

<http://www.thehawaiiindependent.com/story/mayor-peter-carlisle-makes-life-difficult-for-honolulus-houseless-with-pede/>. (accessed January 28, 2011)

Figure 23. Prefab Coat by Takehiko Sanada 68

"Prefab Coat." Takehiko Sanada. [http://www.takehiko-](http://www.takehiko-sanada.com/prefab/index.html)

[sanada.com/prefab/index.html](http://www.takehiko-sanada.com/prefab/index.html) (accessed October 12, 2010)

Figure 24. Final Home Jacket by Kotsuke Tsumura.....	70
"Final Home." Final Home. http://www.finalhome.com/en/2006/10/final_home.php (accessed November 28, 2010)	
Figure 25. Vessel by Justin Gargasz.....	72
Gargasz, Justin. "Vessel." Core 77, Inc. http://www.coroflot.com/ (accessed December 4, 2010)	
Figure 26. Connector Mobile Village by Lucy Orta.....	75
Photo Left: Collection of the Artists. "Body Architecture – Foyer D." Studio-Orta. http://www.studio- orta.com/artwork_fiche.php?fk=body%20architecture&fs=0&fm=0&fd=0& of=1 (accessed November 26, 2009)	
Photo right: "Less – Alternative Living Strategies." Design Boom. http://www.designboom.com/contemporary/less.html (accessed December 11, 2010)	
Figure 27. Wearable Architecture Chart.....	78
See Figure 23-26 for photo credit.	
Figure 29. Inflate-a-Potty.....	89
"Inflate-A-Potty The Portable Inflatable Sanitary Toilet Solution, Adult Size." Safety Central. http://safetycentral.com/inflateapotty.html (accessed November 14, 2009)	
Figure 30. Thermal Survival Blanket.	89
"SPACE® Brand All-Weather Hooded Thermal Survival Blanket." Safety Central. http://safetycentral.com/hoodalrefbla.html (accessed November 14, 2009)	
Figure 31. Light Stick.....	90
"12 Hour Green Lightsticks (4 Pack)." Amazon. http://www.amazon.com/12- Hour-Green-Lightsticks- Pack/dp/B0007MW2MU/ref=sr_1_5?ie=UTF8&qid=1304587519&sr=8-5 (accessed November 14, 2009)	
Figure 32. Radio Flashlight Cell Phone Charger.....	91
"Eton American Red Cross Microlink FR160." Preparedness. http://preparedness.com/etamredcrmif1.html (accessed May 4, 2011)	
Figure 33. Lifestraw.....	91
"LifeStraw - Introduction." Vestergaard Frandsen. http://www.vestergaard- frandsen.com/lifestraw/lifestraw (accessed November 14, 2009)	

Figure 34. Study 1 The North Face Tents.....	115
Marinas, Cherri. 1/22/2011.	
Figure 35. Study 2 Pole Construction.....	116
Marinas, Cherri. 3/28/2011.	
Figure 36. Study 3 Parti Diagram.....	117
Marinas, Cherri. 3/28/2011.	
Figure 37. Study 4.	118
Marinas, Cherri. 3/28/2011.	
Figure 38. Study 5.	119-120
Marinas, Cherri. 3/28/2011.	
Figure 39. Study 6.	121-122
Marinas, Cherri. 3/28/2011.	
Figure 40. The Compleat Retreat Prototype	123-133
Marinas, Cherri. 3/28/2011.	