

**Catalytic Voids: Reprogramming Chinatown Alleyways by Utilizing  
Their Intrinsic Facades**

Ria Lyn Sardo Mitchell

May 2013

*Submitted towards the fulfillment of the requirements for the Doctor of Architecture degree*

School of Architecture  
University of Hawai'i at Mānoa

**Doctorate Project Committee:**

Kris Palagi - Chairperson

Priyam Das

Geoffrey Lewis

**Catalytic Voids: Reprogramming Chinatown Alleyways by Utilizing  
Their Intrinsic Facades**

Ria Lyn Sardo Mitchell  
May 2013

*We certify that we have read this Doctorate Project and that, in our opinion, it is satisfactory in scope and quality in fulfillment as a Doctorate Project for the degree of Doctor of Architecture in the School of Architecture, University of Hawai'i at Mānoa.*

**Doctorate Project Committee:**



Kris Palagi - Chairperson

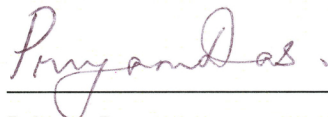

Priyam Das

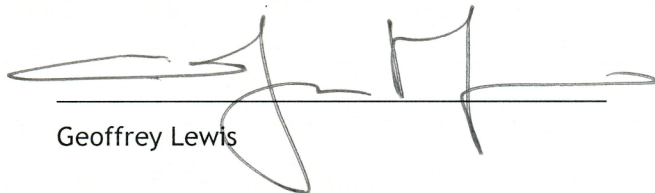

Geoffrey Lewis

## TABLE OF CONTENTS:

	<b>Abstract</b>	<b>1</b>
	<b>Introduction</b>	<b>2</b>
	<b>Existing Knowledge</b>	
<b>1</b>	<b>Context: Macro + Micro</b>	<b>5</b>
	Urban Design Theory	
	Alleyway Typology	
<b>2</b>	<b>Social: Community + Use</b>	<b>12</b>
	Alley Improvement Recommendations	
	Current Alley Projects + Trends	
<b>3</b>	<b>Site: Chinatowns</b>	<b>20</b>
	San Francisco Chinatown	
	Honolulu Chinatown	
<b>4</b>	<b>Material Study: Transformable Systems</b>	<b>28</b>
	Typology + Movement Patterns	
	Telescopic Tube Structure	
<b>5</b>	<b>Existing Knowledge Conclusion</b>	<b>33</b>
	<b>Design Research</b>	
<b>6</b>	<b>Implementation: Honolulu Chinatown Alleys</b>	<b>38</b>
	Macro Site Analysis	
	Micro Site Analysis	
<b>7</b>	<b>Design Proposals</b>	<b>48</b>
<b>8</b>	<b>Project Conclusion</b>	<b>56</b>
	<b>Bibliography</b>	<b>57</b>
	<b>List of Figures</b>	<b>59</b>

## ABSTRACT

This doctoral project studies the intrinsic characteristics of alleyways to identify catalyst moments for reprogramming. Alleyways are underutilized spaces, but with the integration of transformable installations that respond to specific site conditions and user needs, alleyways can be reclaimed for public use. Multiple scales were analyzed in order to catalog alleyway typologies and roles within an urban fabric. Current revitalization projects occurring within alleyways today were also studied to pinpoint successful uses of alleyway spaces. Chinatown alleyways were selected due to their Low-Rise Mixed-Use context and the juxtaposition of the standardized storefront facades with the alleyway facades. The facade of alleyways represents their intrinsic features (materiality, textures, hidden elements and historical characteristics) which makes them unique. A design guideline for choosing and evaluating the alleys was created in order to apply it to any alleyway, specifically the alleys in Honolulu's Chinatown district. The premise is to identify the intrinsic qualities of the alleyways and utilize them with transformable interventions to reprogram their use.

INTRODUCTION

Alleyways exist in various urban settings, but many are abandoned or neglected. This design-research project studies the potential for effective utilization of the spaces that alleyways represent. **Figure 0.1** describes the layout and process of this document. The research portion (denoted in blue circles) is divided into four categories: Context, Social, Chinatowns, and Material Study. Project guidelines were created based on this research and form the overlying system that dictates the direction of the project (illustrated with dashed boxes). The guidelines are implemented to a site, Honolulu Chinatown, and design proposals are suggested. It is determined that the transformable intervention will respond specifically to the alleyway's facade in order to create site-appropriate design. The premise of this project is to utilize the intrinsic qualities of Chinatown alleyway facades to serve as a catalyst to reprogram alleys for community use.

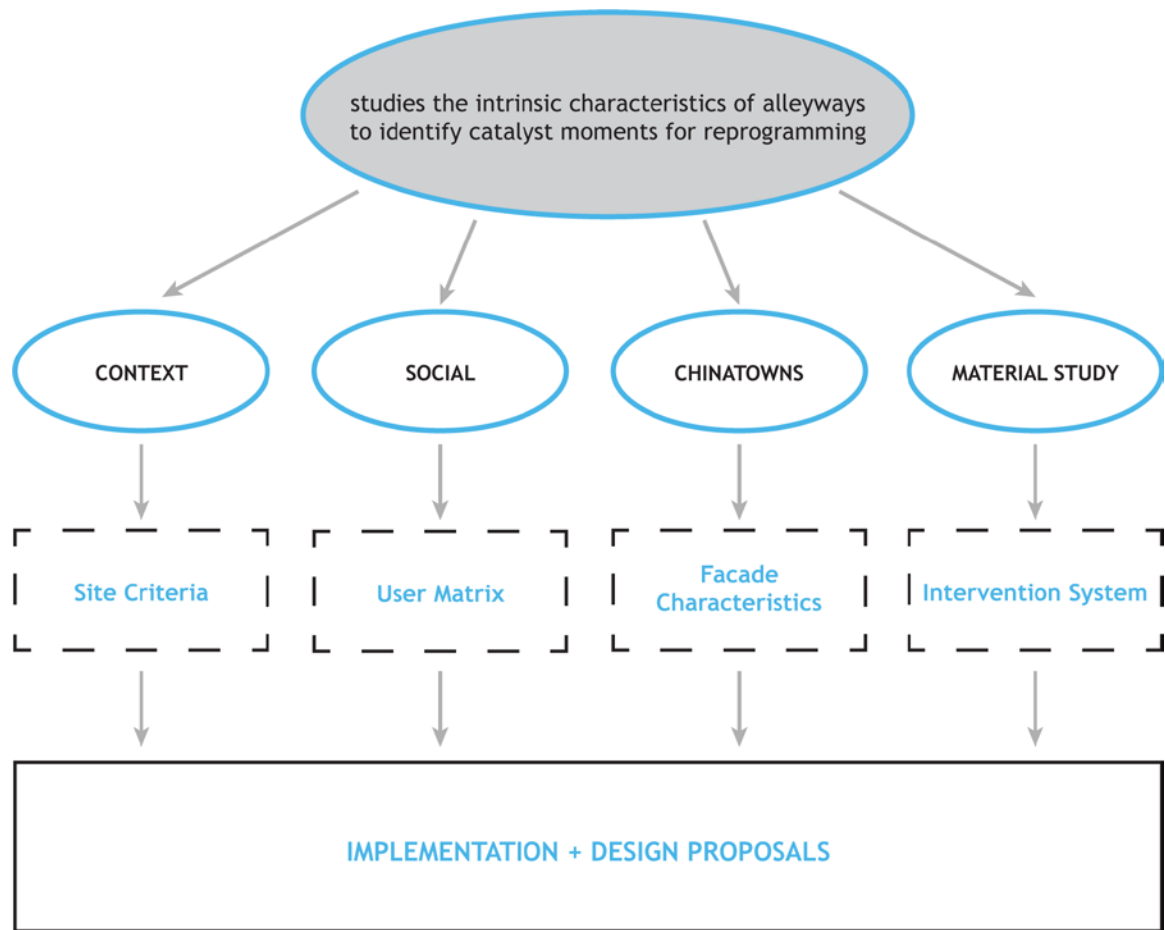

Figure 0.1 Project Breakdown

The first chapter discusses the contextual information of alleyways and their role within a given site, which in turn helps to determine the type of alleyways this project focuses on. The contextual analysis is done in a macro and micro scale. The macro scale study describes how alleys work at a larger context, such as identifying the number of alleyways that exist, their location, the proximity of various alleys to one another and alleyway functions within the urban fabric. The micro scale analysis looks specifically into the different alleyway typologies and its immediate surrounding context of alleyways. It gives a more in-depth overview of what the alleyway is used for, the time of day it is typically accessed and by whom. These studies result in the creation of the "Site Criteria Guideline" and the "Site Analysis Guideline" which are utilized to focus on specific types of alleyways and the process of analyzing them. The "Site Criteria Guideline" dictates that alleyways that fit within the following categories are the subject of this design-research project: reside in Low-Rise Mixed-Use areas, contain no vehicular access, and have a width of less than 15 feet. Once these criteria are met, the "Site Analysis Guideline" is implemented to evaluate and deduce a site-appropriate intervention.

A key component in the study of successful alleyway reprogramming is to analyze the current trends and revitalization projects occurring within them today. This evaluation states the advantages and disadvantages of the projects and establishes the best use of the alleyways. The research begins with looking into alleyway improvement recommendations that address cleanliness and safety issues of alleyways; however, research shows a lack in defining specific use of these spaces. From there, the focus shifts to distinct types of projects that utilize the alleyway such as landscaping, permanent built structures, art murals and community-involvement projects. This study reveals that community-involvement projects are more advantageous in both the utilization of the alleyways as well as having a greater impact in highlighting the potential of alleyways. A "User + Community Events Matrix" is developed to assist in establishing the use of the alleyway and integrates the current events that take place within a chosen site. The alleyway acts as a venue to implement existing community events that the public is already aware of; therefore, employing such events in an alleyway allows for greater success of the utilization of these hidden resources.

Alleyways in Chinatown are the focus of this doctorate project since they fit within the "Site Criteria Guideline" and encompass a large concentration of alleyways. Study of Chinatowns, specifically San Francisco and Honolulu, revealed that special district design guidelines are utilized in maintaining the appearance and architectural character of the area.

These guidelines dictate the look of the front facades of the buildings, but do not address the treatment of alleyway facades. This results in a juxtaposition of the two facades, an important characteristic of these alleyways. Focusing on the alleyway's facade, the "Intrinsic Alleyway Characteristics" diagram is created to emphasize the unique qualities of alleyways. Therefore the alleyway facades are the components that determine the construction of the intervention in order to develop a site-specific design that is fitting for that space.

A transformable system is selected to be installed into the alleyway to allow for adaptable design. Its transformable components (slide, fold, expand, and connect) enables the structure to be modified based on the user's need and fit within specific site conditions. A structure of telescopic tubes is an example of a transformable system that can be implemented into alleyways. The flexible use of the space allows the alleyway to be better utilized overtime.

The design portion of this project begins with implementing the "Site Criteria Guideline" and "Site Analysis Guideline" to the alleyways in Honolulu's Chinatown district. The process starts with the macro scale analysis of the site done through a series of mappings to pinpoint the location of the alleyways. Catalogs of these alleyways are then created to understand its components (orientation, size, surrounding context, etc.). Once all the alleyways are evaluated, one site is chosen to study further and propose a method in applying a transformable system for the utilization of the space.

The transformable intervention is a design tool to showcase the possibilities of reprogramming the alleyways. The telescopic tube system relies heavily on the facades of the alleyways since the facades dictate the placement of the tubes within the space. This results in site-specific design intervention as well as allowing for multiple use of the alley. The function and design are also based on the "User + Community Events Matrix" that outlines the events that occur within Honolulu Chinatown and the required surfaces needed for its respective event. For this project, design proposals for the Farmer's Market and First Friday Art Walk are created to showcase the potential use of the alleyway.

In conclusion, this doctorate project celebrates the intrinsic characteristics of alleyways and how to utilize them to create site-specific design interventions for the alleys. It denotes the alleyway's facade as the underlying component in reprogramming the space and serve as a catalyst for the future use of alleyways.

## 1 CONTEXT: MACRO + MICRO

Contextual analysis is an important design tool in understanding both a site and its surrounding environment in order to distinguish the current conditions and changes that need to occur for the creation of an integrated urban fabric. It is essential to look at a site on both a macro and micro scale. Macro scale analysis identifies the overall site context in terms of how the different elements work as a whole. Micro scale study is a more in-depth analysis of a specific site and its surrounding environment. It helps to define how a single entity works on its own and how it affects the larger context. In this design-research document, the macro and micro contextual information help to identify the location and function of the alleyways within a chosen site.

Void and unused spaces are common sites that exist everywhere. Vacant, derelict, and unused properties, such as alleys, are great opportunities to initiate community development (Figure 1.1). Alleyways are part of the urban fabric throughout the United States and aside from service-related functions they are rarely used for alternative purposes and remain neglected. Contextually, there are two basic types of alleys, "those planned and laid out as a component of the original street grid; and those that are the result of incrementally subdividing larger blocks and lots into smaller properties."<sup>1</sup> From a planning standpoint, alleyways were implemented to serve as secondary or tertiary means of vehicular and pedestrian access, which were primarily for service purposes. This resulted in little cross-traffic and use of the alleys, which ultimately led to the disregard and poor upkeep of the alleys. There are numerous amounts of underutilized alleys that can be great public spaces for the communities in which they reside.



Figure 1.1 Vacant, derelict, unused properties from Larry Ford's *The Spaces between Buildings*

<sup>1</sup> David Winslow, "Living Alleys: A New View of Small Streets," Linden Living Alley, accessed January 17, 2013, <http://lindenlivingalley.wordpress.com/living-alleys-a-new-view-of-small-streets/>.



## A. Macro Scale: Urban Design Theory

The design and planning of a city help to mold the characteristic and essence for which it wants to be known; therefore, understanding the urban design process is important in acknowledging what makes a memorable city. Roger Trancik, an educator and practitioner of urban design at Cornell University, overlays three paradigms for successful urban design: figure-ground, linkage, and place (Figure 1.2). Each of the three components signifies a specific approach to urban design, but when looked at as a whole, they constitute a method that allows a more integrated urban system. Although each theory is important on its own, acknowledging how each component affects the others is the ultimate goal in understanding the makeup of a city.

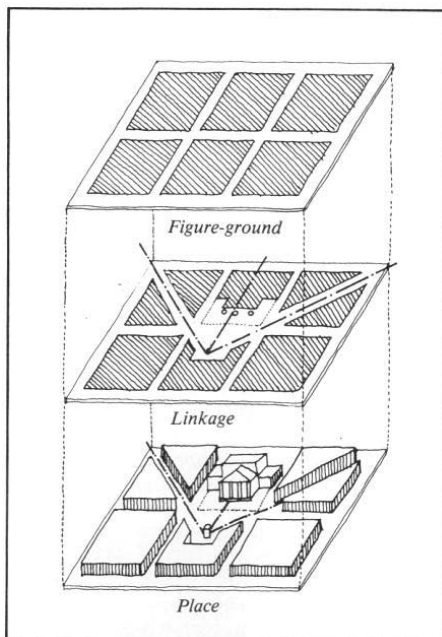

**Figure-ground theory:** manipulate the relationship of solids and voids by adding to, subtracting from, or changing the physical geometry of the pattern. It is a graphic tool for illustrating mass-void relationships.<sup>2</sup>

**Linkage theory:** dynamics of circulation become the generators of urban form. The emphasis is placed on the circulation diagram rather than the spatial diagram.<sup>3</sup>

**Place theory:** adds the components of human needs and cultural, historical and natural context. It gives physical space additional richness by incorporating unique forms and details indigenous to its setting.<sup>4</sup>

Figure 1.2 Urban Design Theories from Roger Trancik's *Finding Lost Space*

Figure-ground theory illustrates the built up space versus the leftover area, which includes circulation space and the spaces in between buildings. Trancik describes figure-ground studies as "useful not only in revealing the composite patterns of street space but also in

<sup>2</sup> Roger Trancik, *Finding Lost Space: Theories of Urban Design* (New York: Van Nostrand Reinhold, 1986), 97-98.

<sup>3</sup> Trancik, *Finding Lost Space*, 97-98.

<sup>4</sup> Trancik, *Finding Lost Space*, 97-98.

indicating the distinctive characteristics of districts."<sup>5</sup> As one can see from the figure-ground maps by Allen Jacobs in *Great Streets* in Figure 1.3, each city has a very unique pattern that highlights the compositional organization of its location. The map of San Francisco, for example, shows two grid patterns that make up the north and south side of Market Street (the diagonal line that shifts the direction of the grid). Figure-ground mappings are important in representing both the circulation system and voids in the fabric that indicate civic spaces, open parks and any other gathering spaces within the city. In the context of this thesis, the figure-ground theory helps to visualize the void and unused spaces of the city, as well as the alley spaces between buildings.

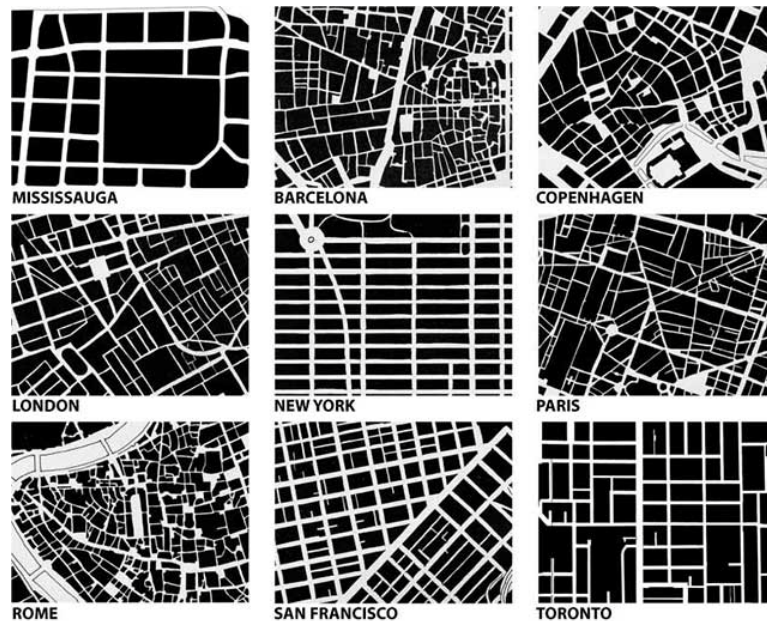

Figure 1.3 Figure-ground maps indicative of its location from Allen Jacobs *Great Streets*

The linkage theory portrays the roadways and circulation spaces more specifically. It consists of the organization of the city, with the width of each link corresponding to the hierarchal system of the roadways: primary as the thickest line, secondary, and tertiary as the thinnest line (Figure 1.4a). Alleys are a part of this circulation system as they are "any street that is the smallest, local serving right-of-way of a hierarchal street system that tends to subdivide a block served by larger streets."<sup>6</sup> Similar to the figure-ground theory, the organization of the links is also indicative of their location. As Roger Trancik explains, whether

<sup>5</sup> Trancik, *Finding Lost Space*, 100.

<sup>6</sup> Winslow, "Living Alleys." <http://lindenlivingalley.wordpress.com/living-alleys-a-new-view-of-small-streets/>.

the links are organized in a grid pattern or more of an organic layout (Figure 1.4b), the “linkage theory involves the organization of lines that connect the parts of the city and the design of a spatial datum from these lines relate buildings to spaces.”<sup>7</sup> The links serve two purposes: they provide a means of connecting spaces and buildings, and a way to dictate the layout and design of buildings.

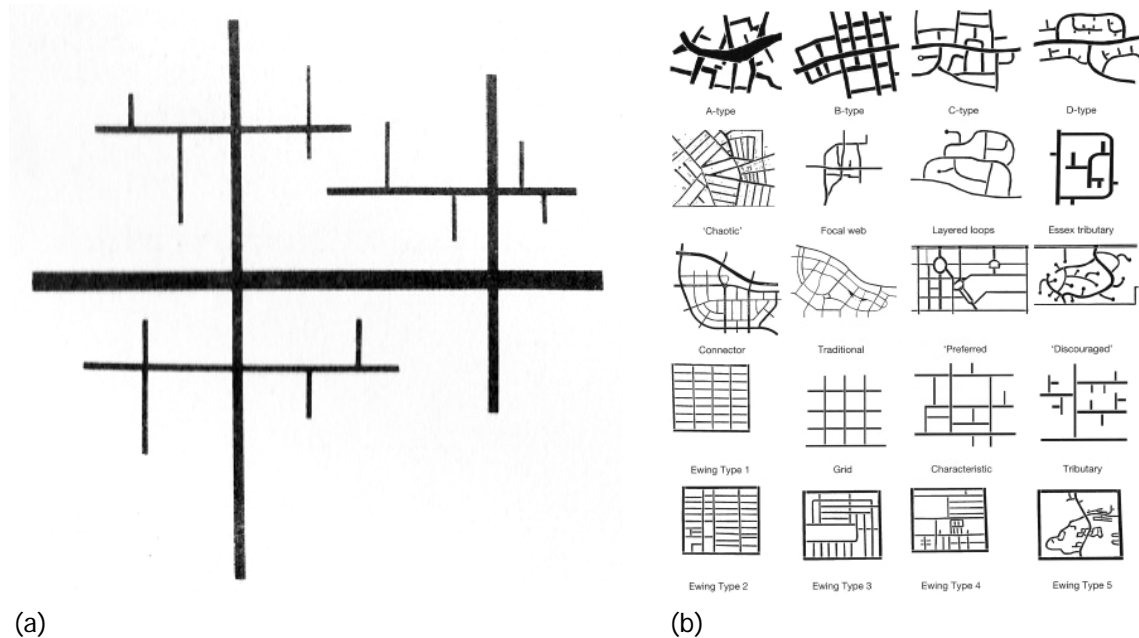

Figure 1.4 (a) Hierarchical Structure of Link Theory from Fumihiko Maki's *Investigations in Urban Form* (b) Different types of street patterns from Stephen Marshall's *Streets & Patterns*

As Trancik describes, “The essence of place theory in spatial design lies in understanding the cultural and human characteristics of physical space.”<sup>8</sup> How humans interact with a space, decorate and assign meaning to the site all help to identify the place. Although the experience of a space is not the same for every single person, it is precisely this fact that makes a place unique for any individual. Architect and author of *Townscape*, Gordon Cullen, compose a series of perspective drawings to replicate the views of his journey through a city (Figure 1.5). This sequence of drawings is a great tool in capturing the unique sense of place of a given site. They illustrate the essence, character and overall look of the space.

<sup>7</sup> Trancik, *Finding Lost Space*, 106.

<sup>8</sup> Trancik, *Finding Lost Space*, 112.

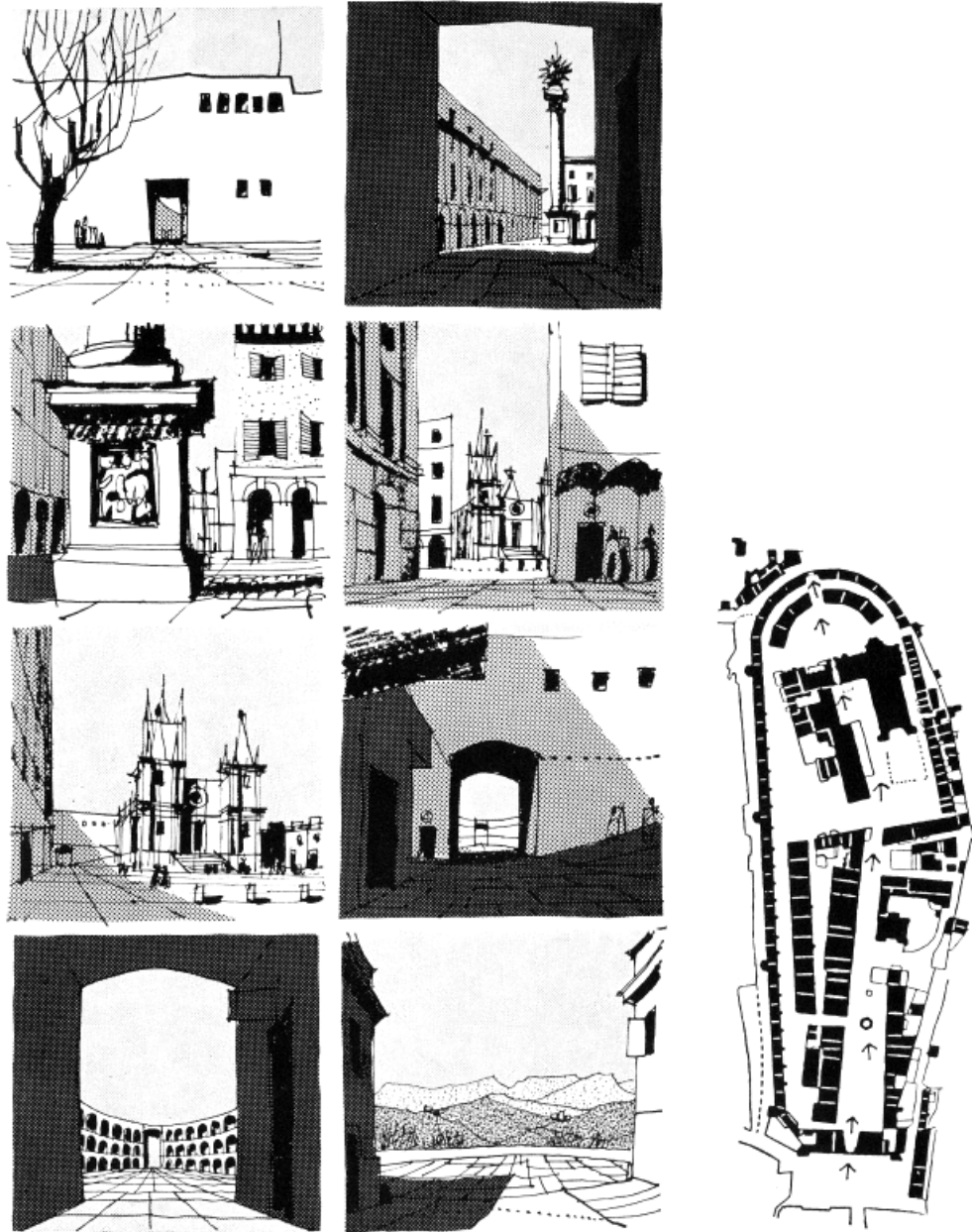

Figure 1.5 Perspective sequence to capture sense of place from Gordon Cullen's *Townscape*

In summary, the Urban Design Theory coined by Roger Trancik can be used to understand the different components that make up a city and how they work together. Analyses of both the macro and micro scale are essential as each builds on the other to create a comprehensive understanding of a site. Alleys function as a part of a system that guide the

movement, connection and character of a city. Studying the workings of this system better informs how alleys are used.

## B. Micro Scale: Alleyway Typology

Alleyways exist in the United States and serve different functions within each setting, but many are underutilized. Studying the different contextual environments in which alleys reside will increase the understanding of the purpose and function of alleys in specific site conditions. The surrounding buildings also serve as an indicator of what the alleyways may be used for in a more cohesive and site-appropriate manner.

In the *Seattle Integrated Alley Handbook*, Mary Fialko and Jennifer Hampton create a catalog of the various alleyway typologies that exist within a city (Figure 1.6). Alleyways fit within one of the six typological settings: High-Rise Mixed-Use, Low-Rise Mixed-Use, Nightlife District, Commercial District, Multi-Family Residential, and Single Family Residential.<sup>9</sup> Each type is defined by the surrounding context and the typical use of the alley within its setting. The High Density and Low Density Mixed Use typologies are great spaces with diverse building uses and community; however, the High Density type includes tall buildings that prevent light or sun exposure to the alley and are key service areas for the buildings adjacent to the alley. The Nightlife and Commercial Districts also utilize the alley as service space and operate at specific times of the day (night or day only). These alleyways would not be the optimum choice as public spaces since there is not a constant flow of people within the area. The Multi-Family and Single Family Residential areas also contain alleyways; however, they are typically utilized by the residents only and not as a public gathering space.

Due to the limited nature of the above-mentioned alleyways, the focus of this project is alleyways that reside in Low-Rise Mixed-Use communities. The mixed-use component of these communities allows for a variety of stores to open and events to occur around or within the alleyway, and guarantees a continuous flow of pedestrians near the site. The shorter buildings within these spaces also allow for more light to penetrate into the alley and create a more intimate setting. These alleyways are ideal locations for community gatherings.

---

<sup>9</sup> Mary Fialko and Jennifer Kempson. *Seattle Integrated Alley Handbook: Activating Alleys for a Lively City*. Seattle, 2011. 16-17.

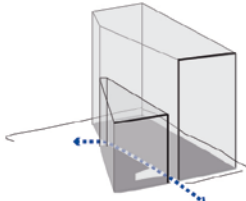
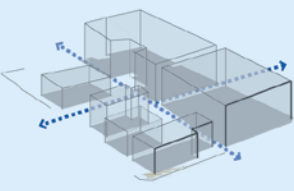
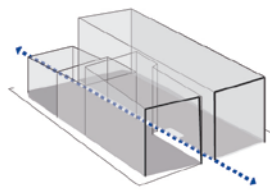
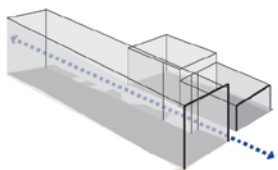
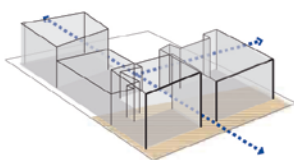
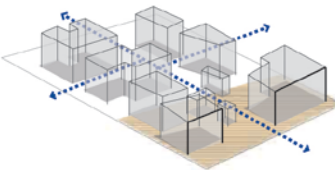
Typology	Description	Analysis
<p data-bbox="381 325 613 357">High-Rise Mixed-Use</p> 	<ul data-bbox="698 367 1201 525" style="list-style-type: none"> <li>- deep due to tall surrounding buildings</li> <li>- office, residential, restaurants, retail</li> <li>- often act as pedestrian passageway</li> <li>- temporary parking</li> <li>- key service areas for surrounding buildings</li> </ul>	<p data-bbox="1242 388 1388 514">Little Sun Exposure and Key Service Area</p>
<p data-bbox="381 609 613 640">Low-Rise Mixed-Use</p> 	<ul data-bbox="698 651 1169 808" style="list-style-type: none"> <li>- lower surrounding buildings</li> <li>- occasionally some empty lots</li> <li>- residential, restaurants, offices, retails</li> <li>- areas for parking, plants, gardens</li> <li>- more sun exposure due to low buildings</li> </ul>	<p data-bbox="1234 661 1388 787">Intimate Setting and Constant Flow of People</p>
<p data-bbox="397 871 597 903">Nightlife District</p> 	<ul data-bbox="698 945 1136 1050" style="list-style-type: none"> <li>- bordering on bars, clubs, restaurants</li> <li>- activate the area at night</li> <li>- pedestrian passageway</li> </ul>	<p data-bbox="1250 955 1372 1029">Night Time Use Only</p>
<p data-bbox="381 1144 613 1176">Commercial District</p> 	<ul data-bbox="698 1207 1201 1302" style="list-style-type: none"> <li>- active retail</li> <li>- potential space for business of all types</li> <li>- at times it has storefronts along the alleys</li> </ul>	<p data-bbox="1242 1207 1388 1302">Frequent Service and Day Time Use</p>
<p data-bbox="357 1386 641 1417">Multi Family Residential</p> 	<ul data-bbox="698 1449 1161 1543" style="list-style-type: none"> <li>- residential adjacent multi-unit bldgs</li> <li>- some have garage access through alley</li> <li>- potential gathering space for</li> </ul>	<p data-bbox="1242 1449 1380 1543">Private (residential) Use Only</p>
<p data-bbox="349 1606 641 1638">Single Family Residential</p> 	<ul data-bbox="698 1669 1209 1795" style="list-style-type: none"> <li>- typically separate backyards of houses</li> <li>- connecting points within &amp; between blocks</li> <li>- garage accessway</li> <li>- more private or local community space</li> </ul>	<p data-bbox="1242 1669 1380 1764">Private (residential) Use Only</p>

Images & Description from *Seattle Alley Handbook*

Figure 1.6 Alleyway Typologies

## 2 SOCIAL: COMMUNITY + USE

Alleys were originally created for storage and delivery space in business districts, and vehicular storage (garages) for residential neighborhoods.<sup>10</sup> However, alleys became spots for homeless people to gather since they were typically hidden and some alleys even became mini-ghettos in Washington DC. After the Depression, governments started to be involved in urban renewal projects and discouraged the use of alleys or even the creation of them in new developments due to the fact that they had become slums in several neighborhoods.<sup>11</sup> Since alleys were rarely used, garages in residential neighborhoods began to face the front of the street and became an integrated part of the design of the house. In commercial areas, large parking garages were needed by the 1940's and 1950's, so alleys were utilized as entrances and exits. However, with the increasing number of cars, the narrow alleys became too hard to maneuver in resulting in moving the entrance to the main street for ease of access.<sup>12</sup> Today, there are revitalization projects being conducted all over the country in an effort to reclaim the alleyways.

### A. Alley Improvement Recommendations

With the deterioration of alleys over the last few decades, several cities have taken action and developed handbooks to help improve overall appearance and safety of the alleyways. The "Seattle Integrated Alley Handbook" and "Chicago Green Alley Handbook" are examples of the different methods used to clean up alleys to encourage public use. The improvement recommendations range from adding landscape elements to repaving the ground to better assist with water runoff from surrounding buildings. Whether these recommendations become a reality or not, the simple fact that they exist sheds light on the abundant number of underutilized alleys within the city fabric.





**Seattle Alley Handbook:** In Seattle, graduate students Mary Fialko and Jennifer Hampton produced the "Seattle Integrated Alley Handbook" in which they studied, cataloged, and made recommendations to improve alleyways. The handbook includes suggestions such as paving, lighting, canopies, landscaping, opening facades, identifying the alleys, furniture, and water runoff, treatment and collection (**Figures 2.1**). These recommendations call for simple and cost-effective solutions rather than intensive redesigns of alleyways.

---

<sup>10</sup> Larry Ford, *The Spaces between Buildings* (Baltimore, MD: Johns Hopkins University Press, 2000), 142.

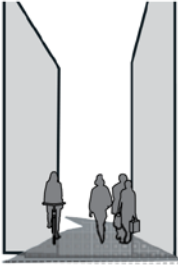
<sup>11</sup> Ford, *The Spaces between Buildings*, 143.

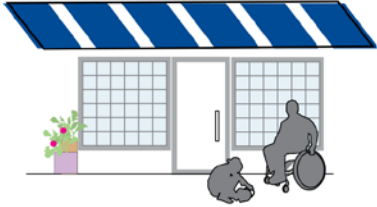

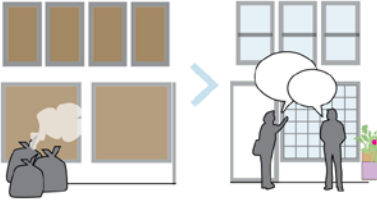

<sup>12</sup> Ford, *The Spaces between Buildings*, 148.

Alley Recommendations	Description
<p data-bbox="492 323 570 350">Paving</p> 	<ul style="list-style-type: none"> <li>- great impact in alley improvement</li> <li>- consider material, strength, color, style, environmental impact</li> <li>- reflective material reduce heat</li> <li>- recycled material reduce carbon footprint and typically more cost effective</li> </ul>
<p data-bbox="483 659 578 686">Lighting</p> 	<ul style="list-style-type: none"> <li>- imperative to maintain safe alley environment</li> <li>- encourage pedestrians &amp; artful elements</li> <li>- discourage crime</li> <li>- light fixtures for outdoor use &amp; dark sky compliant to avoid light pollution at night</li> <li>- LED are low energy lighting option</li> <li>- keep in mind ambiance &amp; mood of space</li> </ul>
<p data-bbox="477 1010 581 1037">Canopies</p> 	<ul style="list-style-type: none"> <li>- low-cost option for spatial reconfiguration</li> <li>- create intimate spaces</li> <li>- protection from natural elements</li> <li>- draws attention &amp; entice pedestrians to the alley</li> <li>- placed high enough to retain service access but low enough to keep rain out</li> </ul>
<p data-bbox="459 1304 599 1331">Landscaping</p> 	<ul style="list-style-type: none"> <li>- adding plants is fast and effective way to make a noticeable difference in the alley</li> <li>- help improve air quality, atmosphere, &amp; increase inviting feel of an alley</li> <li>- using plants appropriate for the space (sun/shade levels &amp; weather patterns)</li> <li>- edible plants may also be an option</li> </ul>
<p data-bbox="431 1587 626 1614">Opening Facades</p> 	<ul style="list-style-type: none"> <li>- transparency + access between inside and outside promotes awareness in the alley = safety</li> <li>- secondary entrance into buildings facing alleys</li> </ul>

Images & Description from Seattle Integrated Alley Handbook

Figure 2.1.1 Alley Improvement Recommendations

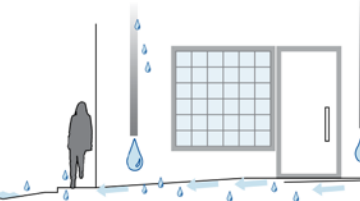

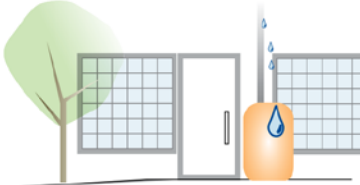
Alley Recommendations	Description
<p data-bbox="483 321 578 348">Identity</p> 	<ul style="list-style-type: none"> <li>- alleys with names, art, businesses, public land marks or points of interest can be indicated in maps = more accessible to the public</li> <li>- names give identity which people are more likely to remember</li> </ul>
<p data-bbox="475 621 586 648">Furniture</p> 	<ul style="list-style-type: none"> <li>- furnitures help reclaim the alleys for pedestrian and public space</li> <li>- great location for bike racks</li> <li>- eating areas for nearby cafes + restaurants</li> </ul>
<p data-bbox="448 936 613 963">Water Run-Off</p> 	<ul style="list-style-type: none"> <li>- paving pitched properly for water to runoff</li> <li>- often roof drains into alleys so keep in mind where the water will travel to</li> </ul>
<p data-bbox="386 1230 675 1257">On-Site Water Treatment</p> 	<ul style="list-style-type: none"> <li>- onsite filtration into the soil</li> <li>- permeable pavers can filter water to soil below</li> <li>- drainage on side rather than middle of alley</li> </ul>
<p data-bbox="435 1587 626 1614">Water Collection</p> 	<ul style="list-style-type: none"> <li>- collection + filtration system that can be used to adjacent garden, roof garden, etc.</li> <li>- non-potable water used for nearby homes or businesses = toilet water</li> </ul>

Images & Description from Seattle Integrated Alley Handbook

Figure 2.1.2 Alley Improvement Recommendations

**Chicago Green Alley Handbook:** With the largest concentration of alleys in America, the City of Chicago created a sustainable handbook to better utilize these alleys, and particularly to target cleanliness and water runoff issues. The handbook states four sustainable goals it wishes to implement for the revitalization of the alleys: environmental technologies to help manage stormwater, heat reduction in urban areas, promotion of recycling and energy conservation.<sup>13</sup> The majority of the examples provided in the handbook, clarify the type of materials to use in repaving the alleys in order to achieve their goals. For example, **Figure 2.2**, illustrates in plan and section view how to implement recycled, permeable surfaces into alleyways for a cleaner and safer environment.

**Green Alley Pilot Approach Example #2: Full Alley Infiltration Using Permeable Pavement**

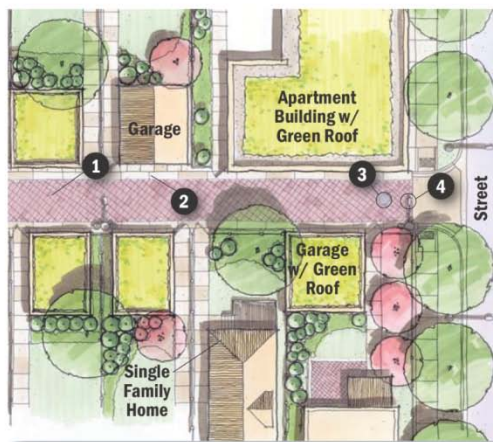

Plan

1. permeable pavement material (permeable asphalt, permeable concrete, or pavers)
2. high albedo concrete paving with recycled aggregate and slag
3. optional inlet structure with pipe under drain
4. energy efficient dark sky compliant light fixture

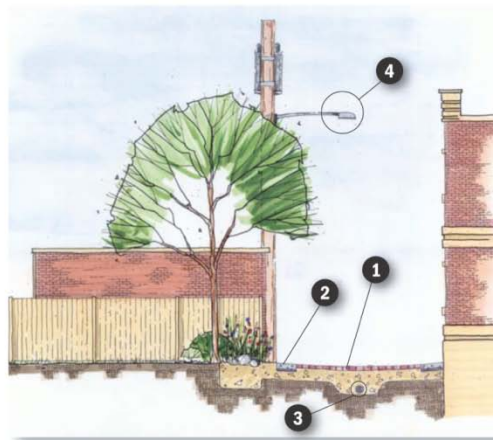

Section

1. permeable pavement material (permeable asphalt, permeable concrete, or pavers)
2. high albedo concrete paving with recycled aggregate and slag
3. optional pipe under drain
4. energy efficient dark sky compliant light fixture

**Figure 2.2** *Chicago Green Alley Handbook* Permeable Pavers Example

<sup>13</sup> Chicago Department of Transportation, "The Chicago Green Alley Handbook," 2010, page 4, [http://www.cityofchicago.org/dam/city/depts/cdot/Green\\_Alley\\_Handbook\\_2010.pdf](http://www.cityofchicago.org/dam/city/depts/cdot/Green_Alley_Handbook_2010.pdf).

In summary, these alley improvement handbooks begin to address the cleanliness and safety of alleys, but not its use. This is a great effort to bring attention to the potential of alleyways as usual spaces, but still fall short of giving guidance for actual space utilization. Since alleys typically have negative connotations attached to them, the simple act of cleanliness goes a long way in initiating the reuse of alleys.

## B. Current Projects + Trends

This section will discuss the current alley revitalization projects and their benefits, but also the lack of site integration within each scheme. The projects are categorized into four overlying sections based on the most common types of interventions that occur in alleyways today: Landscaping, Permanent Built Projects, Art Murals and Community Involvement Projects.

**Landscaping:** A great way to enjoy and brighten up the alleys is to incorporate landscaping elements (Figure 2.3); however, these projects ignore the alley's facades and on occasion even hide them. Also, a few landscape projects are just placed in the location rather than integrated into the site. Functionally, landscaping projects provide sitting spaces, but offer little to no specific use of the space.



Figure 2.3 (a) Seattle design competition for new vision of alleys  
(b) Green Alley Project in Detroit (c) Mainstreet Alley gathering place

**Permanent Built Projects:** There are several built projects situated in alleyways that are very intriguing in the way they make use of the small, narrow spaces (Figure 2.4). Although fascinating, these projects block-off access through the alleys and ignore their facades. While this creates a provocative example of how alleys can be utilized, it can only be used for that specific purpose (office, residential, etc.) and by certain people, not as a public space.

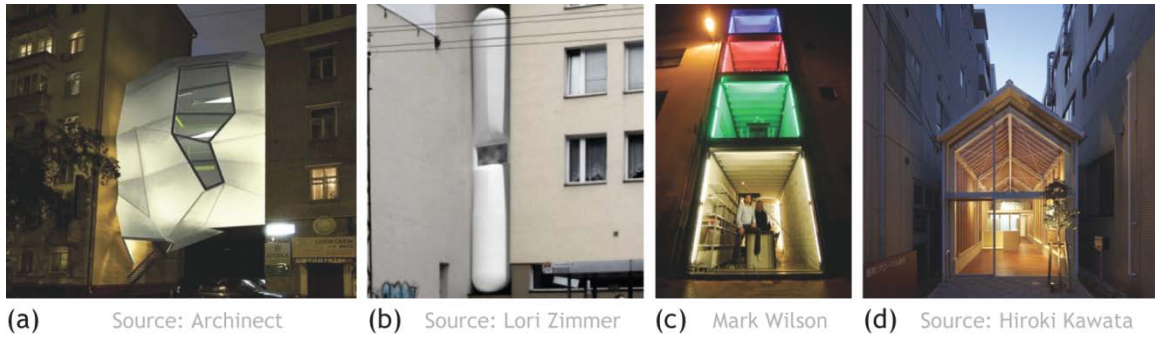

Figure 2.4 (a) Floating office (b) Narrow house (c) Shipping container house (d) Pharmacy

**Art Murals:** Painting and artworks are simple and cost-effective projects that can be adapted into alleyways (Figure 2.5). It is a great approach to showcase local artists and talents, as well as to illustrate the history of the neighborhood. Unfortunately, these works of art cover up the history of the alley and the alley's unique characteristics and textures.



Figure 2.5 (a) San Francisco's Clarion Alley (b) *Culture contains the seed of resistance that blossoms into the flower of liberation* (c) Local Ann Arbor artist works on mural

**Community Involvement Projects:** These types of projects allows for the collaboration of the community, which enables the community to be involved and take pride in their work (Figure 2.6). In Seattle, for example, a local alley activist group created the "Alley Event Handbook" in order to showcase how to organize a community event in alleyways (Figure 2.7). It is a great tool for understanding and initiating public events. These types of projects create a more successful use of the space in terms of community awareness, but again, the alley characteristics are lost. The events are simply plugged into the alley without site integration.



Figure 2.6 (a) Watching the World Cup (b) Community event in Nord Alley, Seattle (c) Local community project in Troy, NY

## PLAN YOUR ALLEY EVENT

When people come to an alley event, they're often amazed to be watching a film, hearing great music, or simply hanging out. Changing the perception of alleys as places for crime or garbage into places to be used by everyone is not only possible, but happening all over the country and the world.

Alleys in Melbourne, San Francisco, Chicago and Seattle – to name a few – are being changed into usable and creative public spaces. Opening stores and restaurants into the alleys, installing lighting, arts, and plants, or finding ways to treat stormwater are all part of the realm of possibilities.

Here in Pioneer Square, The Alley Network Project has learned the nuts and bolts of hosting events in alleys. We would like to share that knowledge for anyone interested in learning about cleaning up their alley and hosting events. Below is a guide in helping you throw a great event!

## PLANNING SCHEDULE

### at least 2 months prior

- SET THEME:** art or visual installation, music, food tastings, film, performance
- SET DATE:** check if other events are happening on same day to piggy-back
- COMMUNICATE** with neighbors on the block
- PARTNER** with volunteers and assign roles
- RAISE** funds
- SEEK** donations
- START** permit application
- SEND** save-the-date

### 1-3 weeks before event

- 3 weeks: send out invitation
- 3 weeks: distribute postcards, flyers at local businesses
- 1 week: send reminder
- 1 week: get signed permit

### 2 hours before event

- close alley and place barricades
- clean and set up alley (see 'preparing the alley', next page)

### Setting Up Food and Drink

- Estimate food quantity
- Food options
  - food cart vendor
  - potluck
  - local business donations
- Table suggestions
  - 6 foot table for food
  - 6 foot table for beverages
  - 6 foot table for community displays
- Alcoholic beverages
  - The Washington State Liquor Control Board can give you permits for serving alcohol indoors or outdoors.
- Display table for community participants
  - event information, sign-up sheets and other information



Photo by Mira Poling, courtesy ISI

### Decorations and Other Ideas

- Flowers
- Lights, candles
- Seating (moveable chairs invite people to stay and sit)
- Photography: assign a volunteer or hire a professional to take pictures

### Preparing the Alley

- Barricades or cones to close the alley
  - Ensure access to parking garages (partial alley closure)
  - Remind neighbors and businesses what areas will be blocked off so that deliveries can continue as scheduled
- Request cleaning the alley from the Metropolitan Improvement District (if downtown Seattle) or the waste company that serves your area
  - Cleanscapes: 206.859.6700
  - Waste Management: 206.505.9057
- Volunteer cleaning: enlist volunteers to clean your alley if you're unable to find service providers (need hoses brooms, etc.)
- Guide people into your alley. Some suggestions:
  - A-boards
  - Balloons
  - Signage

After the event make sure you leave the alley CLEANER than you found it!

Figure 2.7 Sample pages from "Alley Event Handbook"

## C. Conclusion

There are a number of alleyway projects appearing in cities such as Seattle and San Francisco that are shedding light on the hidden resource that alleyways represent. The most successful type of project in terms of popularity and awareness are community involvement projects. Group-oriented events tend to involve larger numbers of people and are spread through the rest of the community, increasing the opportunity to inspire further alleyway reclamation projects.

### 3 SITE: CHINATOWNS

Chinatowns in the United States have a very distinct character and appearance that is recognizable everywhere. They all have similar traits that define them as being Chinatowns, such as the architectural features, building height, and predominance of shop-houses. With these identical characteristics, Chinatowns are ideal locations as a base map to identify similar traits in different settings. They also fit within the description of the alleyway typology of Low-Rise Mixed-Use, which is the focus of this design-research project. This section will focus on the Chinatowns in San Francisco and Honolulu.



Figure 3.1 (a) San Francisco, CA Chinatown (b) Honolulu, HI Chinatown

#### A. San Francisco Chinatown

**Chinatown Area Plan:** With San Francisco's Chinatown being such a popular tourist destination and important city landmark, an urban design guideline has been created by the City and County of San Francisco to maintain the appearance and environment of Chinatown. The main objective of the guideline is to preserve the distinctive urban character, physical environment and cultural heritage of Chinatown.<sup>14</sup> In order to achieve these goals, the following rules must be observed: "maintain the low-rise scale of Chinatown's buildings (75% of the structures in Chinatown are three stories or less); promote a building form that harmonizes with the scale of existing buildings and width of Chinatown's streets; protect the historic and aesthetics resources of Chinatown."<sup>15</sup> It is important to note that these guidelines only refer to the design of the front of the buildings, as illustrated in **Figure 3.2**.

<sup>14</sup> San Francisco Planning Department, "Chinatown Area Plan," San Francisco General Plan: Chinatown, July 6, 1995, 4-6, accessed March 17, 2013, [http://www.sf-planning.org/ftp/general\\_plan/Chinatown.htm](http://www.sf-planning.org/ftp/general_plan/Chinatown.htm).

<sup>15</sup> San Francisco Planning Department, "Chinatown Area Plan," 1995, 4-6.

San Francisco Chinatown Urban Design Guidelines

Facade Differentiation:



UNACCEPTABLE



ACCEPTABLE

At the ground level, independent entrances to shop help to establish separateness of facades. Proceeding upward, differences in belt course design and elevation: window size, proportion, placement; window frame design; cornices, parapets, etc.

Harmonize Facade w/ Existing Elements:

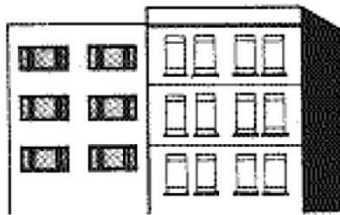

UNACCEPTABLE

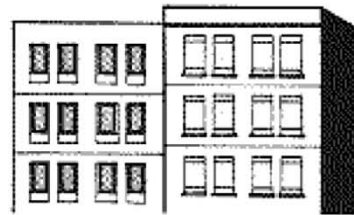

ACCEPTABLE

Floor to floor heights should not be so low as to prevent the creation of facades that harmonize with the proportions of the dominant architecture of the Chinatown area.

Building Height + Ratio:

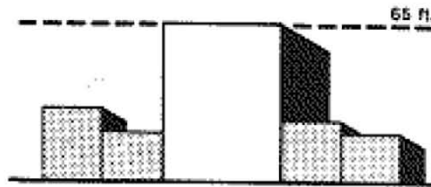

UNACCEPTABLE

This building has nothing in common with its smaller neighbors. It breaks the rhythm of the street and overwhelms the adjacent buildings with its excessive bulk.



ACCEPTABLE

A slender building with a height to width ratio of 2.5 to 1 and shares similar width with its small neighbors.

Source: San Francisco Planning Department "Chinatown Area Plan"

Figure 3.2 San Francisco Chinatown Urban Design Guidelines



**Chinatown Alleyway Master Plan:** The *Chinatown Alleyway Master Plan* originated from a number of years of community efforts to improve Chinatown's numerous alleyways. There are 41 alleys within Chinatown's core area, of which 31 are planned to be renovated through the Master Plan.<sup>16</sup> As stated in the report, "Like the rest of Chinatown, the alleyways were integral to the City's urban fabric from the earliest point in San Francisco's history" as its streets are part of the first official mapping of the city.<sup>17</sup> Therefore, it is an important task to maintain the character of Chinatown, as well as its alleys. In order to preserve the area, the *Chinatown Alleyway Master Plan* defines three goals it wishes to achieve<sup>18</sup>:

1. recognize Chinatown's alleyways as a flexible system of open space - adaptable as needed for passive or active recreation
2. secondary pedestrian network linking together the major community activity centers
3. recognize Chinatown's alleyways as a community asset and develop a supportive infrastructure to raise and maintain the quality of the alleyway environments

Along with these goals, the Master Plan illustrates the different methods in which they went about cataloging and diagramming the different alleys. In **Figure 3.3**, the alleys are depicted in both plan (a) and elevation (b) to show the locations of the alleys and physical characteristics that surround them. Another key diagram the guidelines show is how the different alley typologies are cataloged to describe the alleys use, orientation, size and ownership, which can be seen in the highlighted portion of **Figure 3.4**. The data collected served as important information for choosing and prioritizing the need for alley restoration.

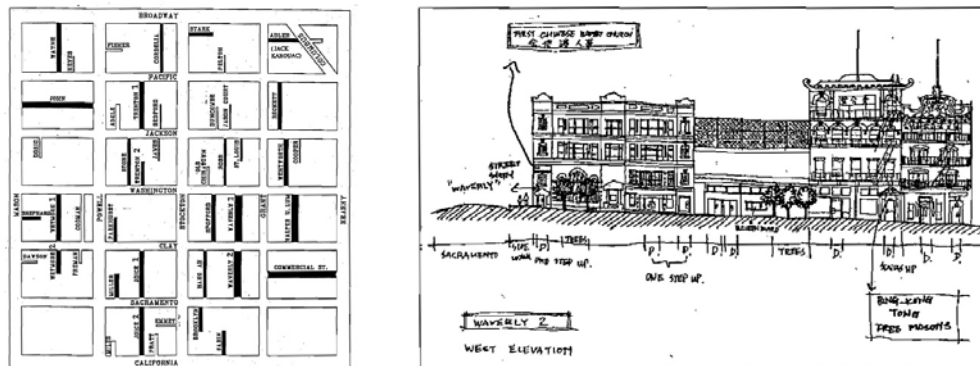

**Figure 3.3 (a) Mapping SF Chinatown alleys. (b) Alley façade studies and diagrams**

<sup>16</sup> Chinatown Community Development Center and San Francisco Department of Public Works, *Chinatown Alleyway Master Plan*, report, (San Francisco, 1998), 1, 7.

<sup>17</sup> Chinatown Community Development Center, *Chinatown Alleyway Master Plan*, 7.

<sup>18</sup> Chinatown Community Development Center, *Chinatown Alleyway Master Plan*, 4-5.

	Types							Dimensions				Ownership				
	North-South	East-West	Destination	Passageway	Dead-end	Through	Residential	Commercial	Mixed-Use	Width PL/PL (ft. & in.)	Width Curb/Curb (ft. & in.)	Length	Approx. Total Area (SF)	Dedicated <sup>2</sup>	Accepted <sup>3</sup>	Not Accepted <sup>3</sup>
<b>Alleyways</b>																
Beckett	X			X	X			X	22'-7"	13'-4"	275'	6187	X	X		
Bedford	X				X			X	7'-6"	N/A	137.5'	1031	X	X		
Brooklyn	X			X	X		X		20'-0"	10'-2"	137.5'	2750	X	X		
Commercial		X	X			X		X	35'-0"	21'-0"	380'	13300	X	X		
Cooper	X			X	X			X	5'-6"	N/A	135'	742	X	X		
Cordelia	X			X		X		X	17'-6"	11'-0"	275'	4812	X	X		
Hang Ah (Pagoda) <sup>1</sup>	X		X		X			X	16'-0"	N/A	275'	4400	X	X		
Jack Kerouac (Adler)		X		X		X		X	17'-6"	10'-8"	134'	2345	X	X		
Jason Court	X		X		X			X	9'-5"	N/A	138'	1297	X	X		
John		X	X			X	X		30'-0"	17'-11"	412'	12710	X	X		
Joice 1	X		X			X		X	25'-6"	12'-9"/15'-9" <sup>2</sup>	275'	7012	X	X		
Joice 2	X		X			X	X		17'-6"	12'-7"/10'-5" <sup>2</sup>	275'	4812	X	X		
Miller	X		X		X		X		25'-8"	18'-8"	138'	3519	X	X		
Parkhurst	X			X	X			X	17'-7"	15'-11"	137.5'	2420	X	X		
Pelton Place	X			X	X			X	6'-9"	N/A	98'	662	X	X		
Ross	X		X			X		X	3'-7"/10'-10"	N/A	275'	3682	X		X	
Sabin Place	X			X	X		X		21'-6"	12'-11"	137.5'	2956	X	X		
Shephard		X	X		X		X		17'-6"	11'-7"	110'	1925	X	X		
Spofford	X		X			X		X	5'-3"/14'-11"	N/A	275'	4152	X	X		
St. Louis Piece	X		X		X			X	10'-0"	N/A	137.5'	1375	X	X		
Stark		X		X	X			X	20'-0"	11'-4"	137.5	2750	X	X		
Stone	X		X			X		X	17'-6"	10'-3"	275'	4812	X	X		
Trenton 1	X		X			X		X	24'-6"	11'-8"	275'	6737	X	X		
Trenton 2	X		X		X			X	17'-4"	N/A	137'	2374	X	X		
Walter U. Lum	X		X			X		X	36'-3"	19'-10"/24'-7" <sup>2</sup>	275'	9969	X	X		
Waverly 1	X		X			X		X	41'-3"	21'-7"	275'	11344	X	X		
Waverly 2	X		X			X		X	41'-4"	22'-4"	275'	11366	X	X		
Wayne	X		X		X		X		25'-6"	14'-11"	237'	6043	X	X		
Wentworth	X		X			X		X	26'-3"	14'-4"	275'	7219	X	X		
Wetmore 1	X		X			X	X		25'-6"	15'-2"	275'	7012	X	X		
Wetmore 2	X		X		X		X		25'-6"	15'-10"	137.5'	3506	X	X		

Footnotes:

- 1: Data valid since Jan. 97, after the completion of the Hang Ah renovation.
- 2: Dimension varies throughout the alley.
- 3: See Appendix - Ownership and Responsibility.

Source: Chinatown Alleyway Master Plan

Figure 3.4 Catalog of the different alley typologies in San Francisco's Chinatown

San Francisco's Chinatown district provides a great example of the process in maintaining the appearance of the storefront facades and the current alleyway revitalization efforts. The "Chinatown Area Plan" exhibits how the design guideline affects the look and design of the storefront facades but not the alley facades. This creates a clear juxtaposition of the two adjacent walls. The abundance of alleyways within Chinatown is also important components of its urban fabric. To reestablish the role of alleyways in the community, the *Chinatown Alleyway Master Plan* creates a system for recording the different alleys and proposes revitalization methods in order to utilize the alleyways as key elements that define Chinatown.

## B. Honolulu Chinatown

As one of the first developed areas in Honolulu, Chinatown contains the rich history of the city. In Figure 3.5a, the map illustrates how the constructed roadways in 1887 are connected to and lead towards the heart of the city, Chinatown. Today the same area is still considered one of the main attractions of the city and is surrounded by the diverse and integral parts of Honolulu: downtown/financial district, tourist areas of Ala Moana and Waikiki, and Kaka'ako district which is currently being revitalized from its industrial era (Figure 3.5b). As such an important area of Honolulu, Chinatown also has a set of guidelines to help preserve its natural character known as the "Chinatown: Special District Design Guidelines." Similar to San Francisco's "Chinatown Area Plan," Honolulu's guidelines assist in maintaining Chinatown's architectural character. Analyzing the guideline and historical information (Figure 3.6) of Honolulu Chinatown reveals how and why the fabric of the district is the way it looks today.

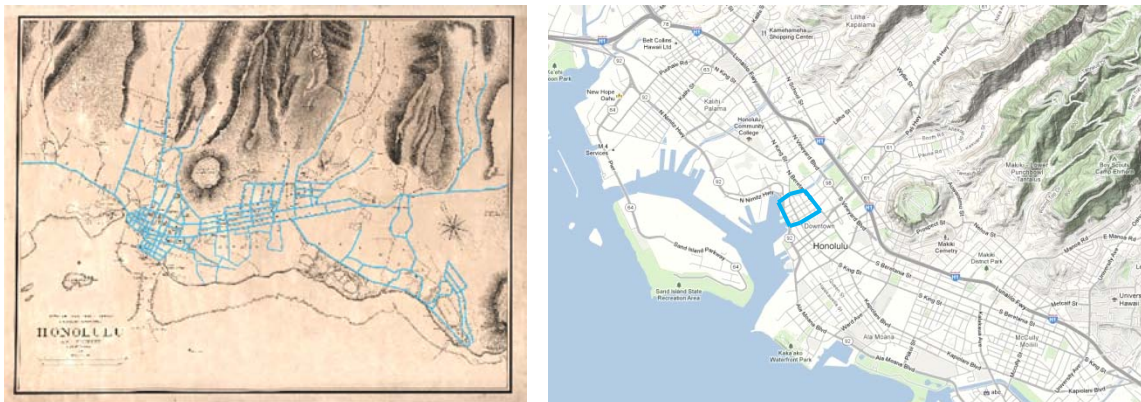

Figure 3.5 (a) Map of Honolulu in 1887 (b) Map Honolulu in 2013

Finding a place of residence was a priority to the Chinese who arrived in Honolulu as tradesmen and plantation workers in the early-mid 1800's.<sup>19</sup> The Chinese took up residence in the current area of Chinatown since it was near the shipping and trading harbor. As more and more men came from China, the development of their community began to expand and they also began to own and operate shops within the neighborhood. At first, the majority of the buildings in Chinatown were 1-story, but with the increase in population during the mid-late 1800's, the architecture turned into 2-story shop houses (shops on the ground floor and housing on the second floor), which became the standard practice in Chinatown.

<sup>19</sup> Info Grafik Inc. "Chinatown's Beginnings." Hawaii History. 2012. Accessed April 12, 2012. <http://www.hawaiihistory.org/index.cfm?fuseaction=iq.page>.

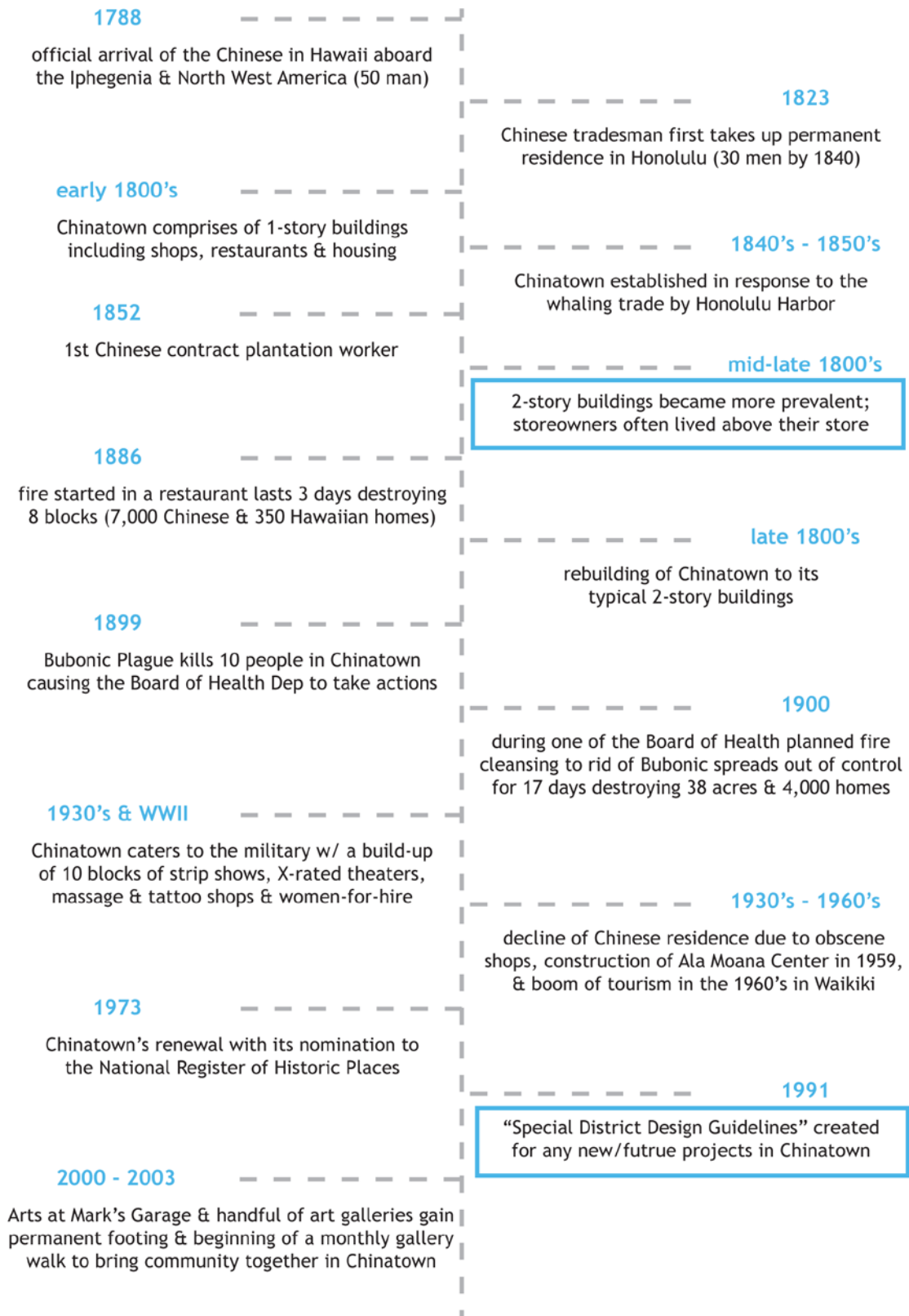
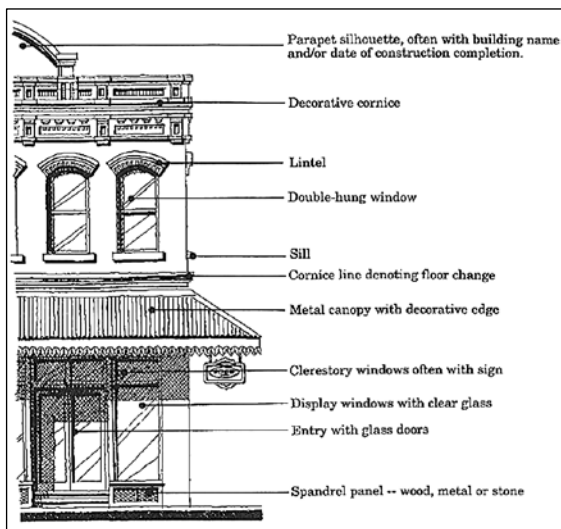

Figure 3.6 Highlighting key moments in Chinatown's history which define its architecture

**Special District Design Guidelines:** In order to preserve and enhance the historic character of Chinatown, the following objectives are stated in the City and County's zoning code and the Land Use Ordinance<sup>20</sup>:

1. Help promote the long-term economic viability of the Chinatown District as a unique community of retail, office and residential uses
2. Retain the low-rise urban form and character of the historic interior core of Chinatown while allowing for moderate redevelopment at the mauka and makai edges of the district
3. Retain and enhance pedestrian-oriented commercial uses and building design, particularly on the ground level
4. Preserve and restore, to the extent possible, buildings and sites of historic, cultural, and/or architectural significance, and encourage new development which is compatible with and complements these buildings and sites, primarily through building materials and finishes, architectural detailing, and provisions for pedestrian amenities, such as storefront windows and historic signage details



(a) Source: Honolulu Department of Land Utilization

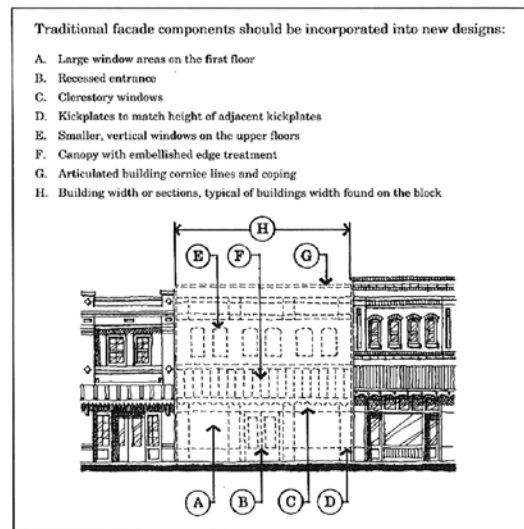

(b) Source: Honolulu Department of Land Utilization

**Figure 3.7 (a)** Typical building façade in Honolulu Chinatown  
**(b)** Façade components required to incorporate for new buildings in Chinatown

<sup>20</sup> Honolulu Department of Land Utilization, *Chinatown: Special District Design Guidelines*, (Honolulu: Department of Land Utilization, City and County of Honolulu, 1991) 3.

## C. Conclusion

San Francisco and Honolulu's Chinatown district are great examples of historical communities that exist within a dense city environment and illustrate the essence of Chinatowns throughout the United States, all which contain a concentration of alleyways. As integral components of the city fabric, several Chinatowns have started to implement design guidelines in order to preserve their architectural appearance and historic character. However, these guidelines only refer to the design of the storefronts facing the main street, not the alleyways. While the front facades are dictated to all look the same, the alleyways are open to design interpretation and unbounded by rules. This in turn creates a wonderful juxtaposition of the facade's texture and form, and the opportunity for the implementation of innovative design to effectively use the alleyway space.

## 4 MATERIAL STUDY: TRANSFORMABLE SYSTEMS

Transformable systems are the best built installation to insert into alleyways due to their ability to change based on user, community events and site conditions. Understanding the different types of transformable systems and their movement patterns are key to creating a successful intervention. The installation that will be used for this project is the telescopic square tube due to its wide range of movements and adaptability.

### A. Typology + Movement Patterns

Transformable architecture is a versatile tool that is able to adapt to different needs of the occupant. Temporary architecture guru, Robert Kronenburg states, "Architecture that is designed for adaptation recognizes that the future is not finite, that change is inevitable, but that a framework is an important element in allowing that change to happen."<sup>21</sup> The type of movement the structure is able to perform is key to the transformability and overall framework of its form and function.

Transformable design can be broken down into four main categories: sliding, folding, expanding, and connections. In **Figure 4.1**, a catalog of these typologies illustrates the different movement patterns and advantages of transformable architecture. The movements of these structures allow for a wide range of opportunities such as hiding or revealing elements and being able to compartmentalize and transport them in an easy manner. They are also capable of creating a wide range of design opportunities with a few extra components and the unique way it is able to create space. The benefit of transformable design is the ability to create more design possibilities for different kinds of spaces and uses less material and effort. The ability for multifunctional use with minimal alterations is the biggest asset of these transformable systems.

A flexible structural system is a great instrument to incorporate and conform to alleyway site conditions. Alleys are narrow and provide little space for built elements to be placed into the site. Transformable structures, with their modular and moveable components, are attractive design solutions to enhance and utilize in alleyways.

---

<sup>21</sup> Robert Kronenburg, *Flexible: Architecture That Responds to Change* (London: Laurence King Publishing, 2007), 115.





Typology	Typology Image
<p><b>Sliding:</b></p> <p>moves along with continuous contact onto surface or rail</p> <p>multiple patterns &amp; forms</p> <p>may alter form based on want or need</p>	 <p><a href="http://stat2.architizer-cdn.com/mediadata/projectuser/222010/r600x450/9110d7fe.jpg">http://stat2.architizer-cdn.com/mediadata/projectuser/222010/r600x450/9110d7fe.jpg</a></p>
<p><b>Folding:</b></p> <p>bend structure upon itself</p> <p>compartmentalized &amp; sectioned for easy alterations</p>	 <p><a href="http://www.dailytonic.com/wp-content/uploads/2009/08/jentzen_2.jpg">http://www.dailytonic.com/wp-content/uploads/2009/08/jentzen_2.jpg</a></p>
<p><b>Expanding:</b></p> <p>system that works as a whole</p> <p>easily transportable</p>	 <p><a href="http://pingmag.jp/2007/07/13/transformablearchitecture/">http://pingmag.jp/2007/07/13/transformablearchitecture/</a></p>
<p><b>Connecting:</b></p> <p>modular pieces</p> <p>easily expandable</p>	 <p><a href="http://inhabitat.com/archinoma-for-the-future-prefab-beach-bum-in-all-of-us/">http://inhabitat.com/archinoma-for-the-future-prefab-beach-bum-in-all-of-us/</a></p>

Figure 4.1 Transformable System Typology

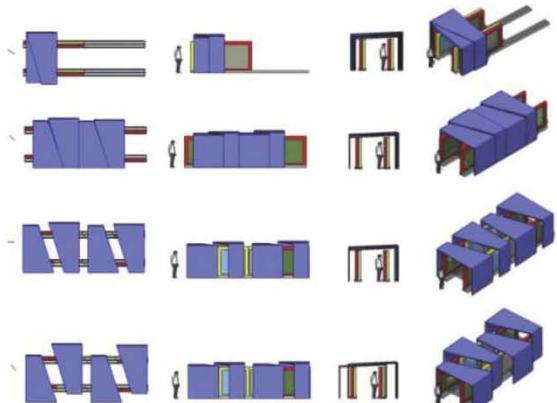

## B. Telescopic Tube Structure

Telescopic tubes are great examples of transformable structural systems, since they are alterable in all four of the movement patterns (Figure 4.2). Telescopic tubes typically include holes to allow for alterations and connections (Figure 4.3). Manufacturers like Unistrut have created catalogs of the wide range of fittings that can be incorporated into designing the desired structure (Figure 4.4). The multiple variations and sizes of the tubes provide for greater design possibilities.

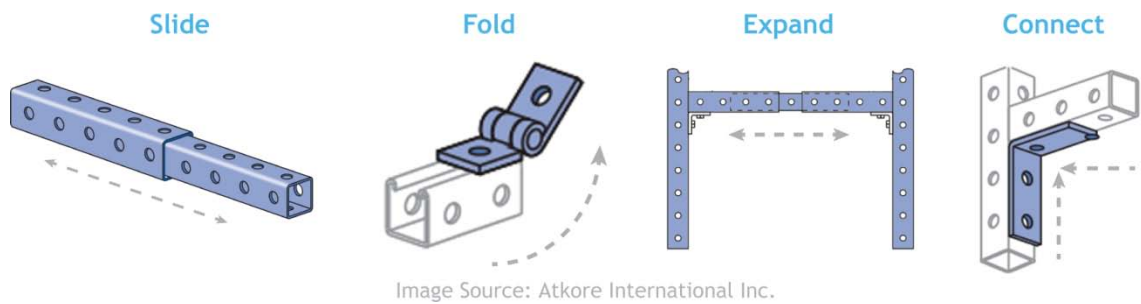

Figure 4.2 Telescopic Tube Structure Movements

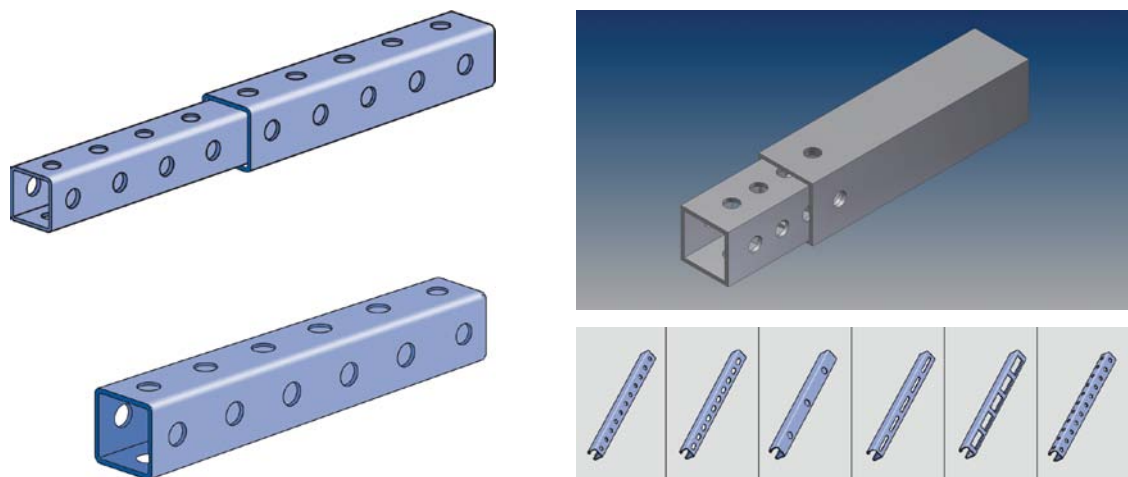

Figure 4.3 Telescopic Tube Structure

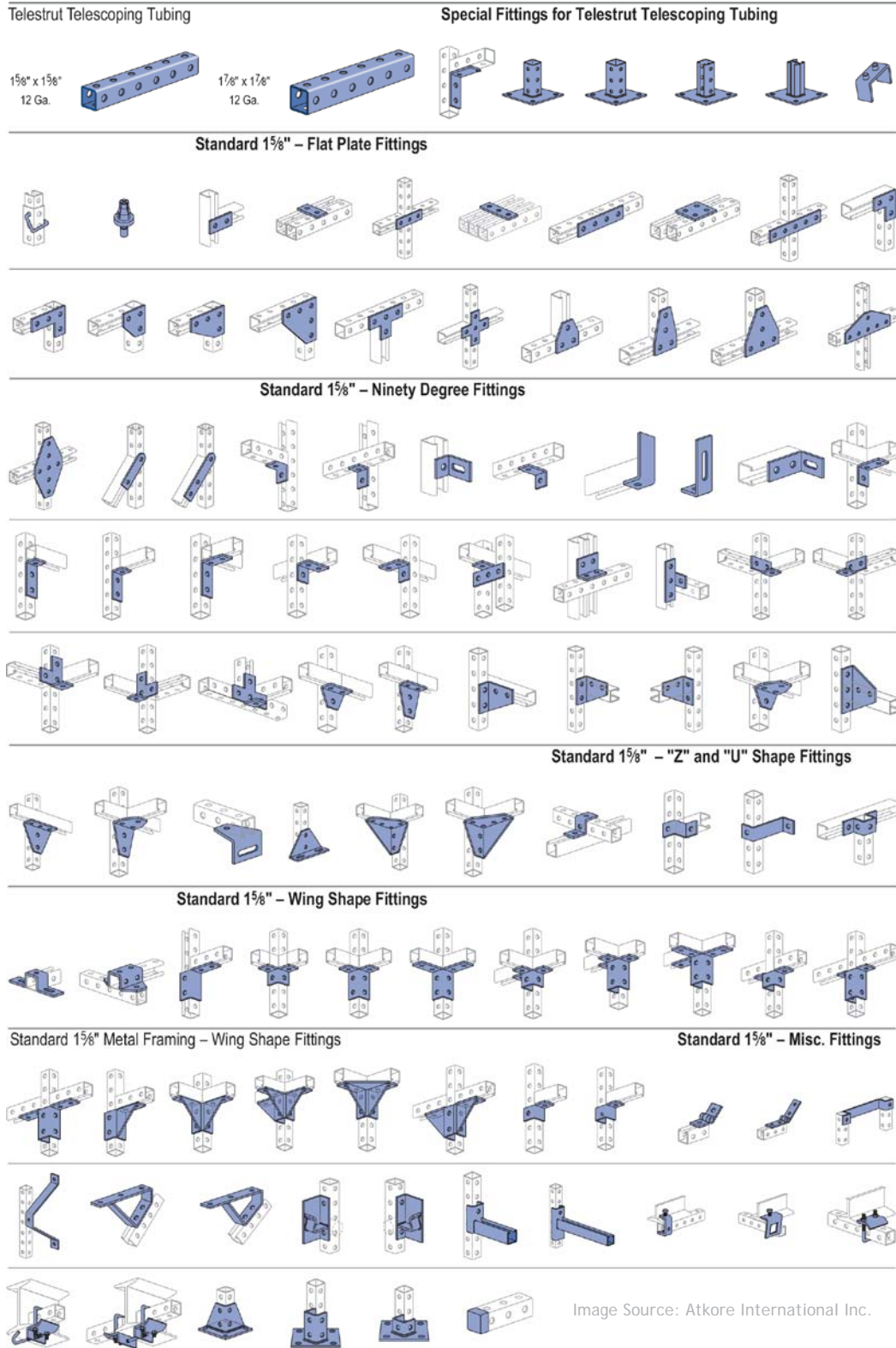

Figure 4.4 Catalog of the wide range of fittings for Telescopic Tubes

## C. Conclusion

Flexible structures are a great way to create adaptable spaces that fit within a wide range of sites like alleyways. Robert Kronenburg explains further the value of transformable design: "In a built environment that is now affected more and more by rapid and dramatic change, ecological considerations, and social and cultural impact, a form of architecture that is flexible, lightweight in construction, has minimal impact on sensitive sites, and is responsive to new technological and aesthetic opportunities has great value."<sup>22</sup> Inserting a transformable structure into alleyways will assist to reprogram and reclaim the neglected space for public use.

---

<sup>22</sup> Robert Kronenburg, *Portable Architecture: Design and Technology* (Basel: Birkhäuser, 2008), Preface.

## 5 EXISTING KNOWLEDGE CONCLUSION

Void and unused spaces occur in varying urban contexts and can be utilized to promote urban growth and renewal. This doctorate project looks specifically into neglected alleyways and seeks to celebrate their unique characteristics. Roger Trancik's Urban Design Theory (figure-ground, linkage and place) provides a framework of how to analyze the contextual information of alleyways in a macro scale. Switching from a macro scale study to a micro scale analysis, alleys are further identified into specific site typologies. Comparing the different typologies led to the selection of alleys that reside in "low-rise mixed use" environments, due to their more intimate setting (low-rise buildings) and the constant flow of people (mixed-use programs). This resulted in the creation of a "Site Criteria Guideline" as the overlying system that determines the type of alley on which this project will focus on (Figure 5.1). Along with the "Site Criteria" diagram, the "Site Analysis Guideline" was developed to assist in the process of choosing a specific site (Figure 5.2). This guideline is a step-by-step process in understanding both the general site context and specific alleyway characteristics, which is based off of the combination of the macro and micro scale mappings and diagrams analyzed in Chapter 1.

Site Criteria	Reason
"low-rise mixed-use" area	human-scale + diverse environment
connection to main road/street	ease of access
alleys less than 15 feet wide	less likely to have vehicular traffic + intimate
little to no vehicular traffic	pedestrian only zone
no residential-only alleys	public gathering space (not private)

Figure 5.1 Site Criteria Guideline

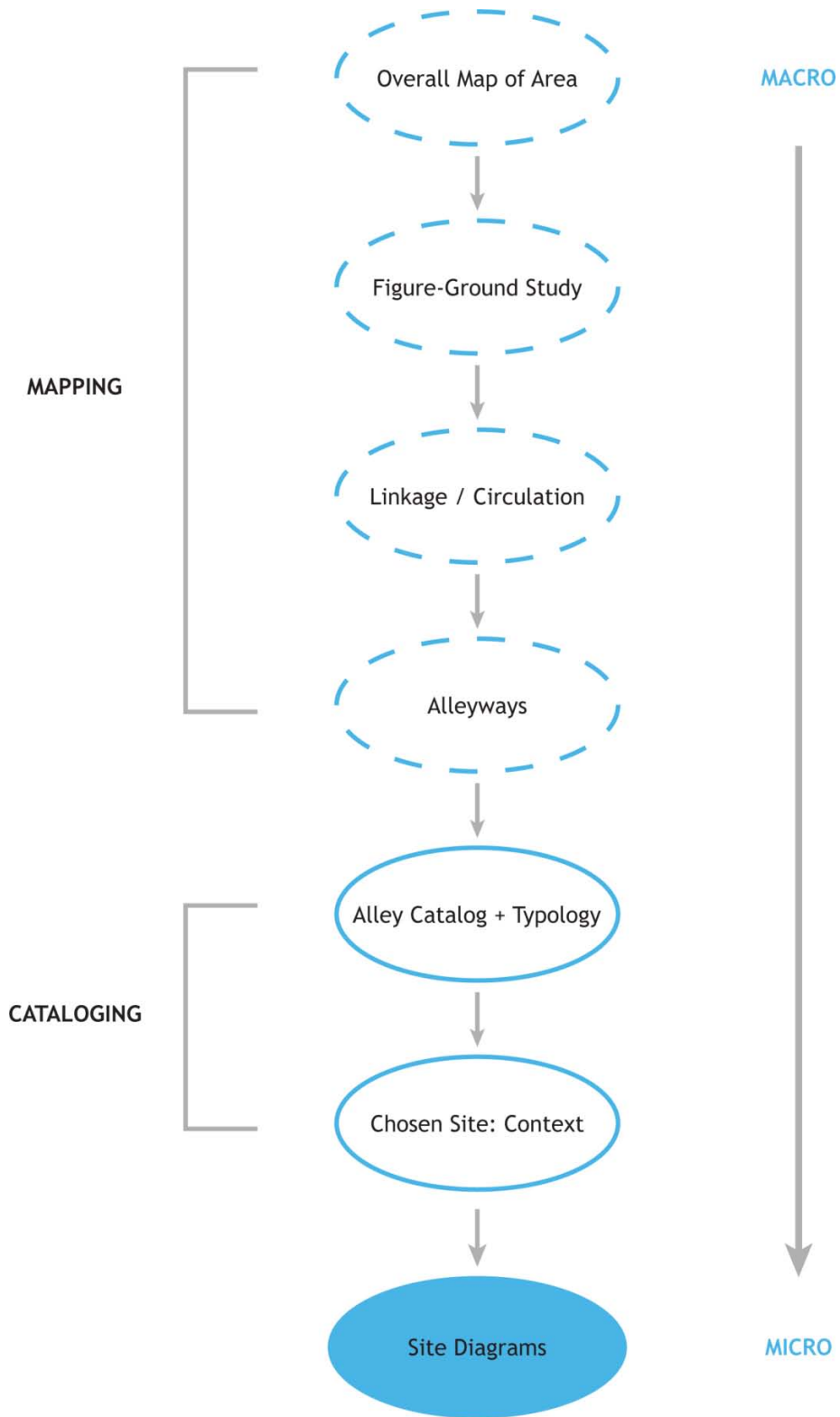

Figure 5.2 Site Analysis Guideline

With the recognition of the potential of alleyway spaces in America, urban planners, government departments, and local communities are starting to explore options for active engagement of alleyways. Projects range from simple alleyway cleanup to inserting permanent built structures within the narrow space. Analysis of the wide range of projects revealed that community-involvement events were the best projects that most effectively engaged community participation and public awareness. It is evident that alleyway revitalization projects can benefit and gain initial momentum by taking advantage of already existing community events and serving as the venue for those events. The "User + Community Events Matrix" was created as a means of initiating the use of alleys by highlighting basic information needed to hold an event in an alleyway (Figure 5.3), such as the need for table surfaces for a local farmer's market event. The essential goal is to catalyze the future utilization of alleyways.

	Users	Time of Use	Required Surfaces
Community Event	local community, financial district workers, children, elderly, etc.	day, night, all day, partial, seasonal, etc.	platform, seat, table, counter, roof, wall mount, etc.

Figure 5.3 Example of User + Community Events Matrix

Chinatowns are recognizable communities throughout the United States that contain clusters of alleyways. San Francisco and Honolulu have design guidelines to maintain the specific appearances of the buildings within their Chinatowns. Through examination of these guidelines, it is clear that the rules only refer to the front facades and not the alleyways, which allows for open-ended design of the alleyway's facade. The juxtaposition of these two facades brings attention to the unique qualities of alleyway facades (Figure 5.4). The materiality, textures, hidden elements, and historical characteristics of alleyways are the intrinsic features that make them unique. It is precisely these qualities that make up the essence of alleys and therefore need to be celebrated and integrated into the design of alleyway revitalization projects.

**Facade Characteristics**

**Examples**

**History:**

relationship of old alleys with new surrounding developments  
 illustrates the historical context of the site (what existed before)



[http://farm1.staticflickr.com/64/193764167\\_c6e379de40\\_z.jpg](http://farm1.staticflickr.com/64/193764167_c6e379de40_z.jpg)



[http://farm7.staticflickr.com/6235/6246400424\\_0bff7a8b3b\\_z.jpg](http://farm7.staticflickr.com/6235/6246400424_0bff7a8b3b_z.jpg)



<http://i617.photobucket.com/albums/tt257/mikeedwardwest/Austin.jpg>

**Materiality + Textures:**

a mixture of building materials  
 finished materials, graffiti, power lines, drain pipes, etc.



<http://www.shawnhoke.com/wp-content/uploads/2010/05/FranklinAlley-copy.jpg>

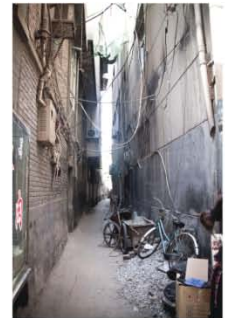

<http://tryabreathmint.com/wp-content/uploads/2012/05/alleyway.jpg>

**Front Facade v. Alley Facade**

juxtaposition of storefronts and alley facades  
 storefronts elaborately designed while alleys are more functional



<http://www.urbanindy.com/wp-content/uploads/2013/01/Alley-Tour-2012-11-10-074.jpg>



[http://farm5.static.flickr.com/4024/4519322782\\_d18df1feab7.jpg](http://farm5.static.flickr.com/4024/4519322782_d18df1feab7.jpg)

**Leftover + Hidden Elements**

wires, pipes, electricity poles, trash cans, fire escapes, etc.  
 hidden elements that add texture and characteristic



<http://i50.tinypic.com/2j5krn.jpg>



[http://www.mediarare.com/GWimages/images/alleylum2BW\\_blog.jpg](http://www.mediarare.com/GWimages/images/alleylum2BW_blog.jpg)

Figure 5.4 Intrinsic Alleyway Characteristics

A design method that can be implemented into alleyways to make them into more usable spaces are transformable structures. These flexible systems are able to adapt to the narrow spaces of alleyways and their facades, as well as to the various potential events that could take place in the alleys. An example of a transformable system that can be applied is telescopic square tubes. The telescopic feature allows the structure to expand and contract easily based on the desired design. The pre-drilled holes within the tubes allow for the connection of different pieces and the insertion of rods for pivoting motions. This system can be utilized to create surfaces such as tables, seating spaces, roof structure, etc. based on the required needs of a specific event. In summary, transformable telescopic tubes are an advantageous apparatus that can assist in the utilization of alleyways through their transformability and adaptability to the site and user needs.

The culmination of the diagrammatic guidelines presented in this chapter will now be applied to find a specific alleyway within Honolulu's Chinatown district to analyze and propose a transformable installation for the alley. The following chapters will go into further detail about the implementation of these guidelines and ultimately the evaluation of the design. This will serve as a catalyst to reprogram the use of alleyways with site-specific interventions.



## 6 IMPLEMENTATION: HONOLULU CHINATOWN ALLEYS

Honolulu's Chinatown district is full of rich history and a cluster of alleys that are underutilized. Pinpointing and analyzing these alleyways are an important step in understanding the context and character of each one. A combination of mapping, cataloging and diagramming these alleys resulted in the selection of a site in which to implement a transformable structure. This installation highlights the intrinsic characteristic of the alley and serves as a model for the utilization of the space for public gatherings. The "Site Analysis Guideline" serves as the overlying framework for choosing and analyzing the site. This section illustrates, on a macro and micro scale, where the alleys are located, their typologies, and the unique qualities of the final chosen site.

### A. Macro Site Analysis

The macro site analysis of Honolulu Chinatown began with a mapping study of the overall district and then a more site-specific catalog of the alleys. The mappings reveal the location of the alleyways, as well as the proximity of community events within Chinatown. Once the alleys have been identified, a catalog study is done to display the alley site conditions and typology. The process began by delineating the area of study (Figure 6.1), followed by the site analysis mappings (Figures 6.2 - 6.5).

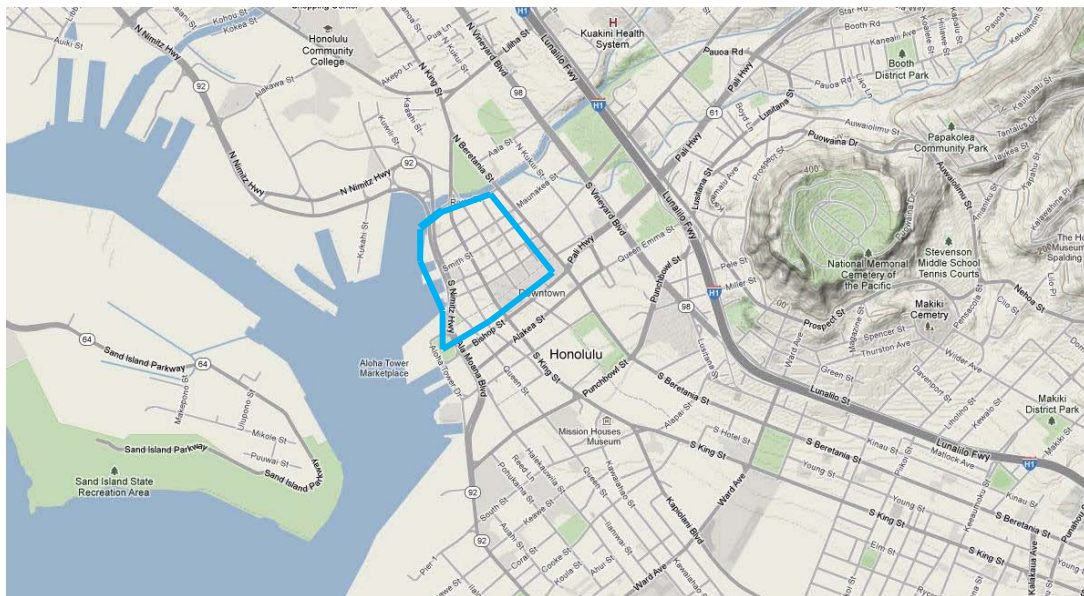

Figure 6.1 Current Map of Honolulu Chinatown

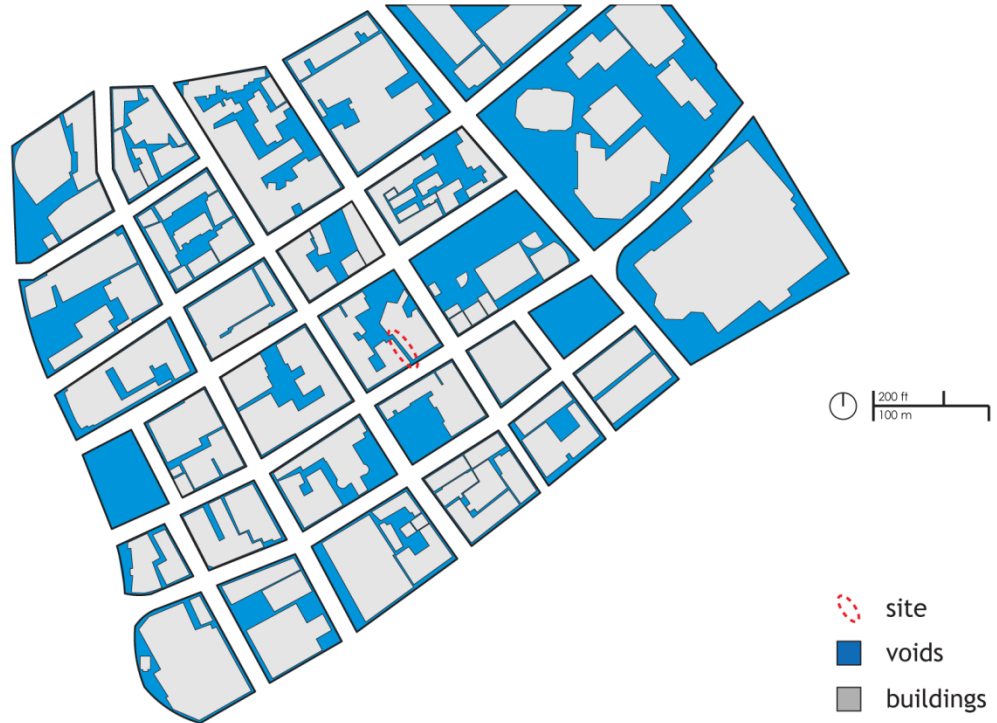

Figure 6.2 Void + Unused Spaces



Figure 6.3 Circulation + Street Types + Alleyway Locations





Figure 6.4 Alley Locations



Figure 6.5 Alleyways + Community Events

Now that the alleys within Chinatown have been identified, the following catalogs will assist in further distinguishing the specific site context in which each alley resides (Figure 6.6). The catalog is broken into two main categories: "Typology" and "Dimensions". Within the "Typology" category, there are four subcategories that help classify each alley: orientation (North-South vs. East-West), use (Destination vs. Passageways), type (Dead-Ends, Throughway vs. Gated Alleys), and surrounding context (Residential, Commercial vs. Mixed-Use). Within the catalog, each alley has been highlighted with either a purple or blue box, which indicates whether or not it fits within the "Site Criteria" established from the previous chapter. Purple represents any conditions that do not fall within the criteria, while blue represents alleys that are potential sites. From the twelve alleys that have been identified, five stand out as ideal sites for an intervention to be implemented. After several site visits and analyses, the alleyway on Nu'uano Street between Hotel Street and Pauahi Street have been chosen to study further and create an in-depth or micro site analysis. This portion is discussed in more detail in the following section.

Alleyways	Typology							Dimensions					
	North-South	East-West	Destination	Passageway	Dead-End	Throughway	Gated	Residential	Commercial	Mixed-Use	Width	Length	Approx. Area (sq. ft.)
<b>Pauahi &amp; Bethel - Fort St Mall</b> 		x		x	x					x	13'-0"	73'-8"	958
<b>Chaplain - Beretania</b> 		x		x		x				x	7'-8"	220'-0"	1,687

Fits w/in Site Criteria:  Yes  No

Figure 6.6.1 Chinatown Alleyway Catalog

Alleyways	Typology								Dimensions				
	North-South	East-West	Destination	Passageway	Dead-End	Throughway	Gated	Residential	Commercial	Mixed-Use	Width	Length	Approx. Area (sq. ft.)
<b>Kekaulike &amp; King - Nimitz</b> 	x			x		x			x		10'-0"	32'-6"	325
<b>King &amp; Maunakea - Kekaulike</b> 		x		x		x	x		x		8'-6"	60'-4"	513
<b>King &amp; Kekaulike - Maunakea</b> 		x		x					x		6'-0"	42'-8"	256
<b>King &amp; Kekaulike - Maunakea</b> 		x		x		x			x		5'-8"	44'-0"	249
<b>Maunakea &amp; King - Hotel</b> 	x		x		x				x		6'-7"	100'-0"	658

Figure 6.6.2 Chinatown Alleyway Catalog

Alleyways	Typology								Dimensions				
	North-South	East-West	Destination	Passageway	Dead-End	Throughway	Gated	Residential	Commercial	Mixed-Use	Width	Length	Approx. Area (sq. ft.)
<b>Maunakea &amp; Hotel - King</b> 	x			x	x		x			x	5'-4"	55'-4"	295
<b>Main &amp; Smith - Nuuanu</b> 		x	x		x					x	19'-8"	85'-2"	1,675
<b>King &amp; Smith - Nuuanu</b> 		x		x		x	x			x	5'-8"	88'-0"	499
<b>Nuuanu &amp; Hotel - Pauahi</b> 	x			x	x					x	9'-0"	102'-4"	921
<b>Nuuanu &amp; King - Merchant</b> 	x			x	x					x	19'-8"	117'-4"	16,378

Figure 6.6.3 Chinatown Alleyway Catalog

## B. Micro Site Analysis

The alleyway on Nu'uuanu Street is a great example of an alley that fits within the "Site Criteria", and showcases the fascinating juxtaposition of carefully maintained storefront and unrefined facade common to many Chinatown alleyways (Figure 6.7). The two facades of the alley not only differ from each other, but also from the front of the building that faces the street. This is a result of the *Chinatown: Special District Design Guideline* that the city of Honolulu put together to preserve the overall look of the buildings within Chinatown, but again, only refers to the front-facing facades. With further site context study, it is evident that the buildings surrounding the chosen alley maintain a similar front facade that is characteristic of Chinatown (Figure 6.8). The buildings range from two-story to three-story with the shops and restaurants on the ground floor and residential or offices above. As a typical attribute of Chinatown, the alleyway is bordered predominately by mixed-use occupancies. This diverse mixture of building uses attract more people to frequent the area, which also implies that there is a constant flow of pedestrians passing by the alleyway.



Figure 6.7 Rendering of chosen site (Nu'uuanu St. & Hotel St. - Pauahi St.)



Chosen Site w/ Grid Overlay of Facade: Nu'uanu Street & Hotel Street - Pauahi Street

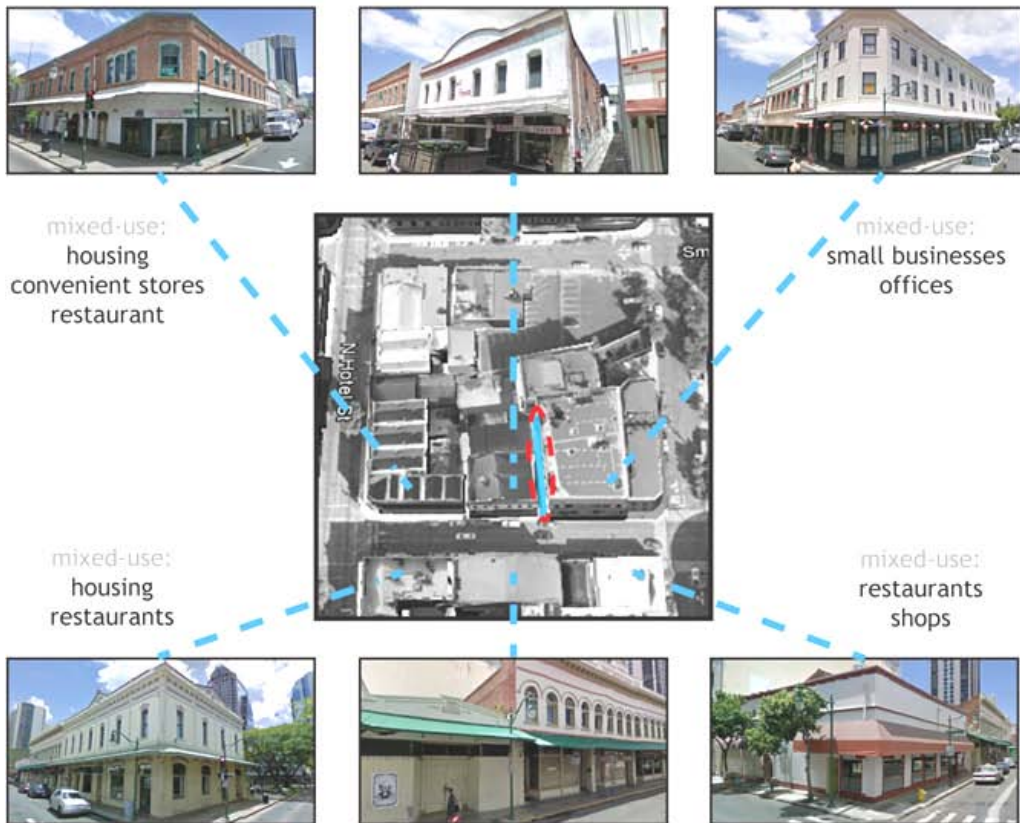

Figure 6.8 Chosen site context with grid overlay to highlight the similar architectural elements



The following figures look into more detail of the facade characteristics of the alleyway. There is a clear difference in design and material of the east and west facade, as well as its relationship to front of the building (Figure 6.9). The east facade displays a more updated and cleaner look, but the strict grid of the window and door placements make it a more monotonous layout (Figure 6.10a). The east facade relates a bit to the front-facing facade, exhibiting a strict grid for the placements of the openings (Figure 6.11). The west facade, on the other hand, has very little correlation to its front facade. The windows on the west side of the alley are located in more of a random pattern, not following a specific grid line (Figure 6.10b). This side of the alley also contains distinct and charming brick material, full of history and layers of paint throughout the decades (Figure 6.12).



Figure 6.9 Panoramic views of alley and surrounding building context

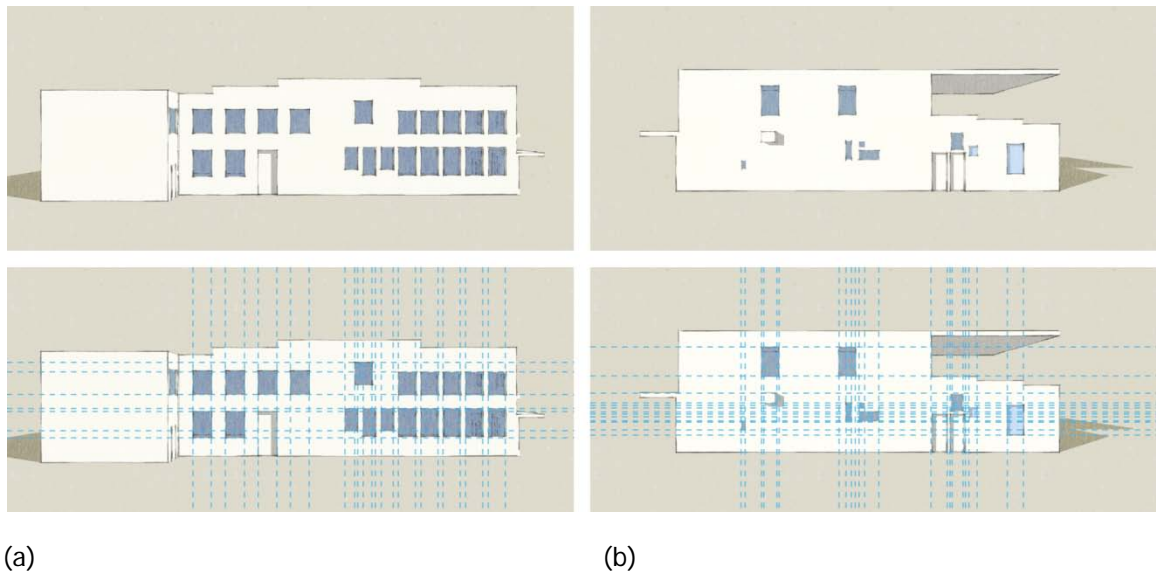

(a)

(b)

Figures 6.10 (a) Grid pattern of west facing facade (b) Grid pattern of east facing facade



Figure 6.11 Rendering of alley's west facing facade

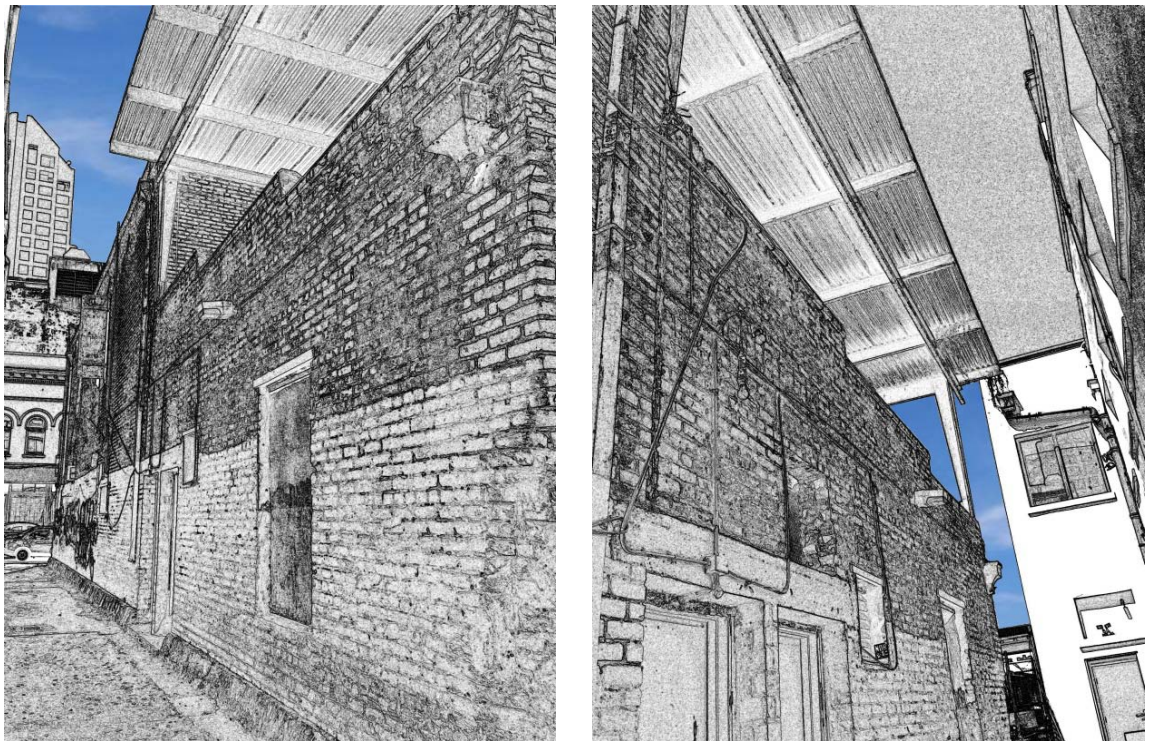

Figure 6.12 Rendering of alley's east facing facade

## 7 DESIGN PROPOSALS

From the mapping and catalog studies done in the previous chapter of the alleys in Honolulu Chinatown, a site has been chosen to implement the transformable telescopic tube structure. To further enhance the purpose of the installation, the "User + Community Events Matrix" is incorporated to apply a specific function within the chosen alleyway (Figure 7.1). The events listed on the matrix are current activities occurring in Chinatown, specifically the farmer's market (Tuesdays and Fridays) and First Friday Art Walk (first Friday of every month). The diagram describes the surfaces, type of users and the time of day the respective events take place. It will help to inform the design of the structure, which is able to transform from one function to another. The telescopic structure will adapt to both the use of the space (farmer's market / First Friday Art Walk) and its site condition (intrinsic facade).

	Users	Time of Use	Required Surfaces
Gathering Space	local community + financial district workers	all day	roof + seats + tables
Farmer's Market	local community + financial district workers	day time (Tuesday + Friday)	roof + tables
1st Friday Art Walk	typically adults (21+ of age)	night time (1st Friday / month)	table surface + mounting surface

Figure 7.1 User + Chinatown Community Events Matrix

Before starting the design intervention, a basic study of horizontal surfaces is required to understand the height and placement within the alley (Figure 7.2). This diagram illustrates the typical location of horizontal surfaces for specific use, such as seating spaces that are to be 18" from the ground. This basic understanding will help to inform the design of the installation.

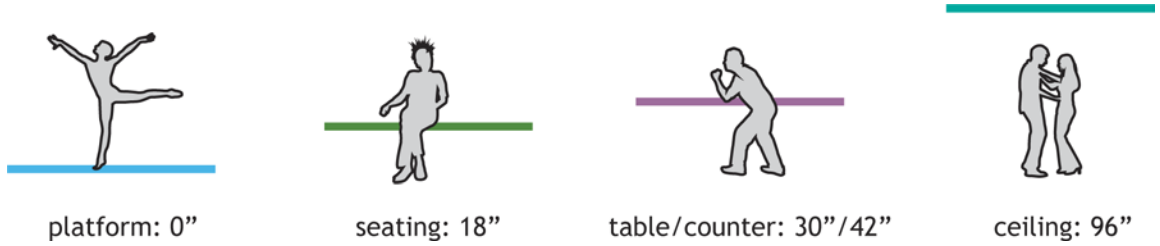

Figure 7.2 Basic Horizontal Surfaces + Heights

The grid overlay of the alleyway's facade and heights for the basic horizontal surfaces are combined in order to visualize how the space is utilized (Figure 7.3). These lines illustrate the potential placement of the telescopic tube intervention. The tube is inserted into the facade's opening based on the program of the space and also highlights the unique facade of the alleyway. The facade openings help to support the telescopic tubes and serve as an anchor for the overall design intervention. Spaces are created by connecting different points of the facade's grid, which also further exemplifies the intrinsic features of the alleyway.

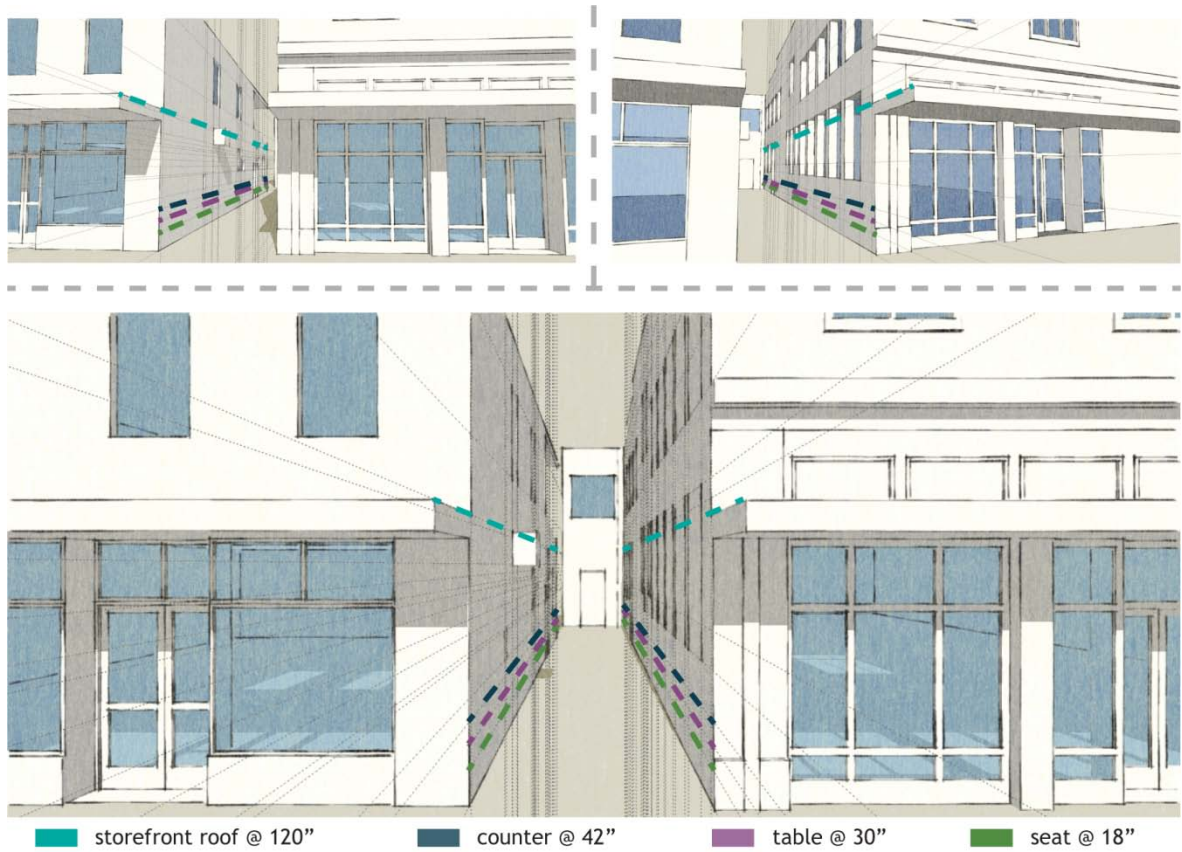

Figure 7.3 Alley Facade Grid + Horizontal Surface Heights

**Canopy + Shelter:** A canopy structure is implemented into the site to illustrate how the alley's facade dictates the design of the intervention. The height of the existing canopy along the storefront facade is highlighted in order to inform the height of the canopy installation (Figure 7.4). The structural components of the canopy are broken down into three parts (Figure 7.5): primary (placed along the alley's facade opening), secondary (helps to define the space), and tertiary (the infill that helps to utilize the space). A final rendering of the installation helps to visualize the potential of the alleyway (Figure 7.6).

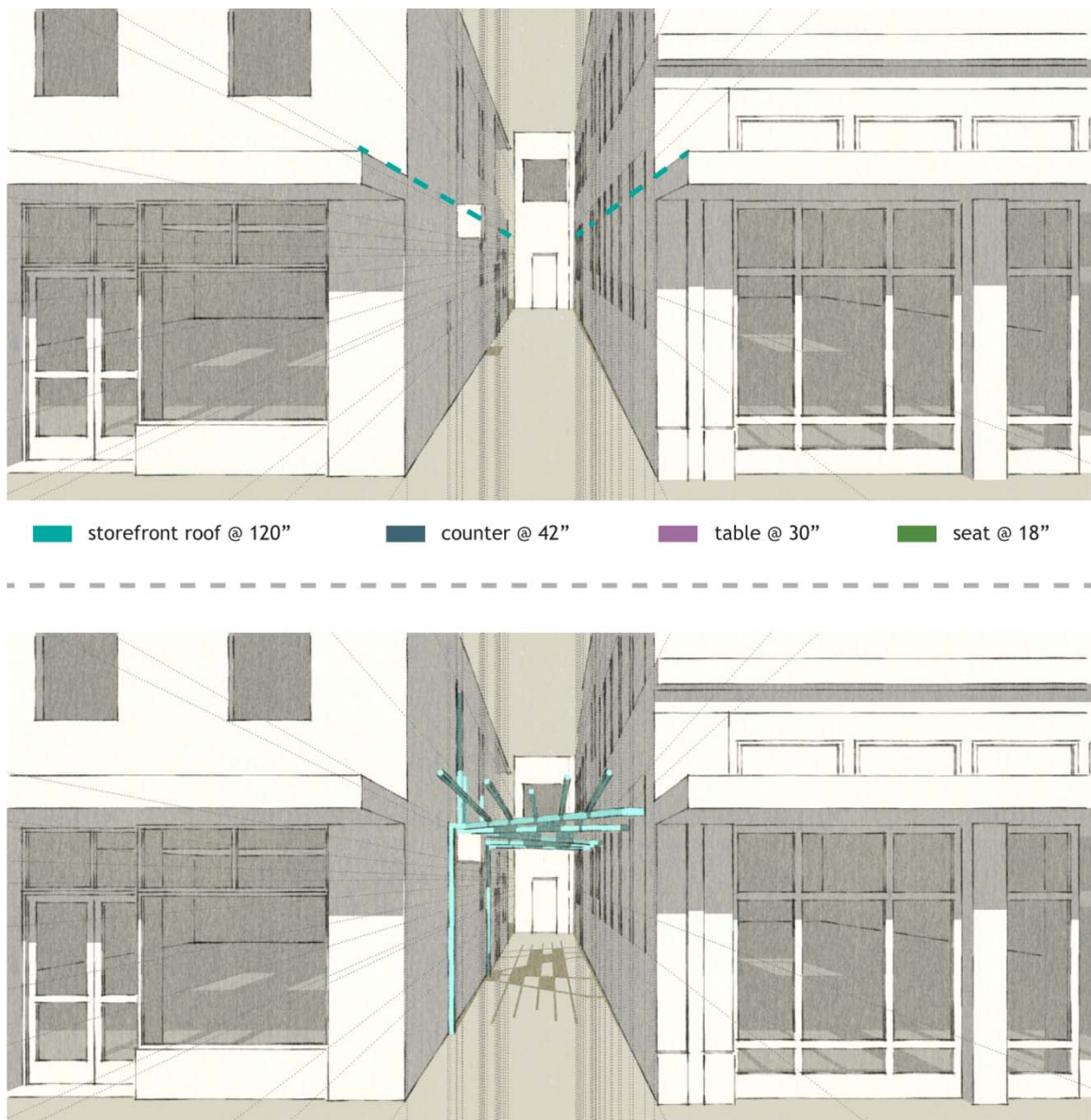
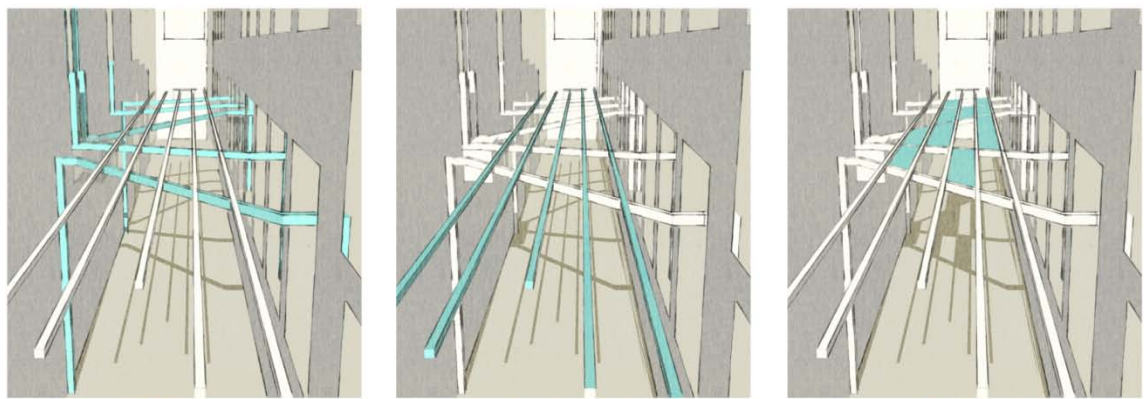
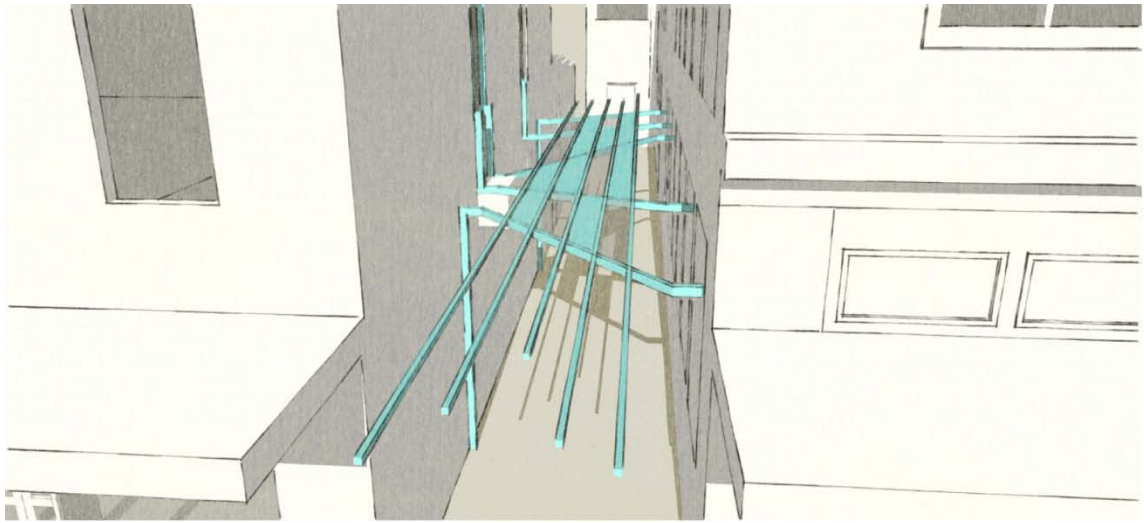

Figure 7.4 Utilizing the alley's facade to support a canopy installation



Primary

Secondary

Tertiary

Figure 7.5 Canopy Structural Components

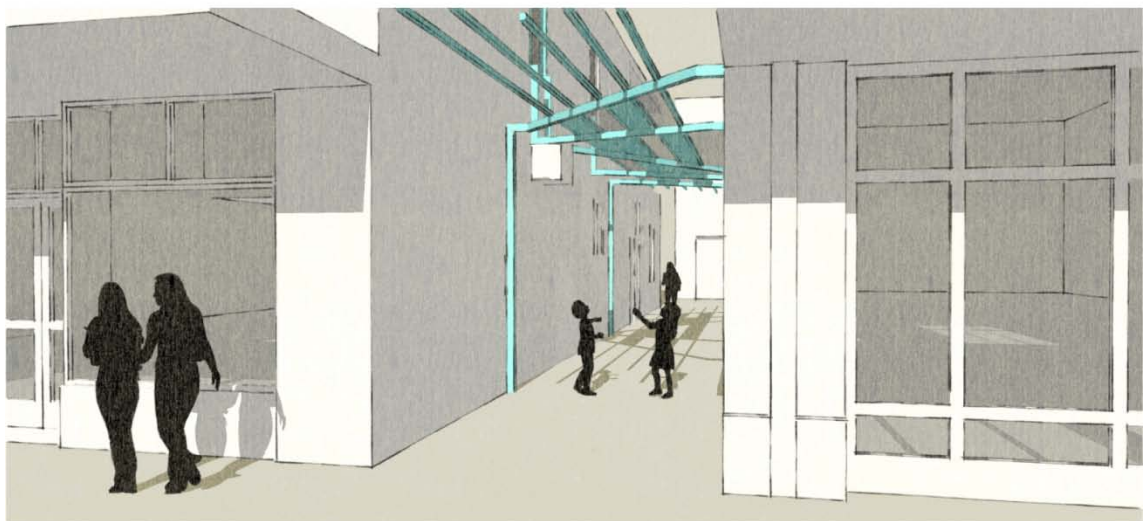
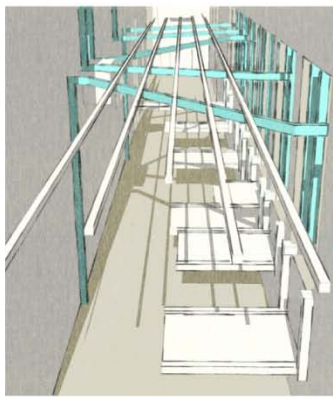
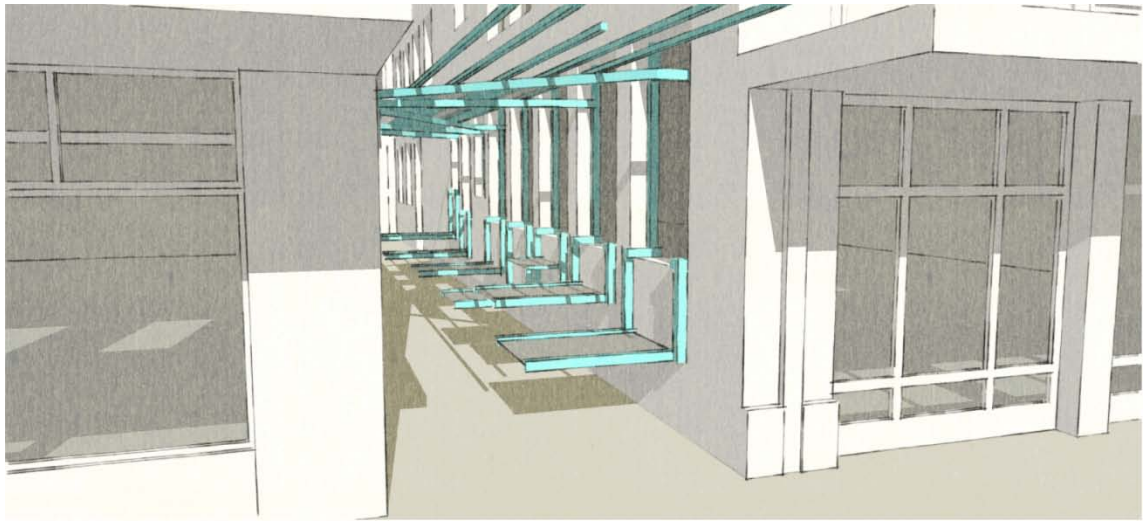

Figure 7.6 Canopy Rendering

**Farmer's Market:** The main design consideration for the farmer's market installation is to provide surfaces for the products being sold. Referring back to the "Basic Horizontal Surfaces + Heights" diagram, tables are to be 30" and counters 42" from the ground (Figure 7.7). In order to achieve this, the alley facades will be utilized to help support the horizontal surfaces, as well as integrate the site conditions within the overall design of the intervention (Figure 7.8). The rendering of the proposed farmer's market design (Figure 7.9) illustrates how basic design elements transform the mood and use of the alleyway.



Figure 7.7 Utilizing the alley's facade to support a farmer's market



Primary

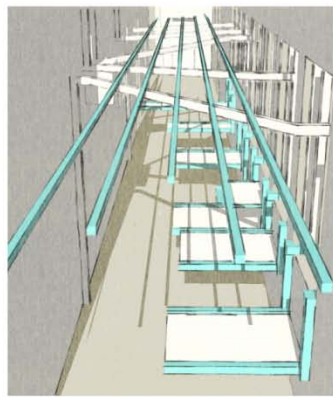

Secondary

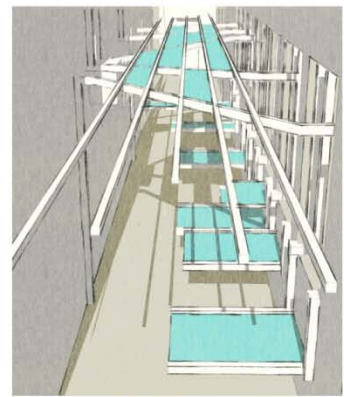

Tertiary

Figure 7.8 Farmer's Market Structural Components



Figure 7.9 Farmer's Market Rendering



**First Friday Art Walk:** With continued interest of rejuvenating Chinatown as a local artist hotspot, a community event entitled "First Friday Art Walk" was established to showcase the talent of local artists from different venues throughout Chinatown. The site of the chosen alley for this project is located in the center of the existing galleries; therefore, participants will be able to view the artwork displayed in the alleyway with ease. Once again, the design of the transformable installation will be able to exhibit the artwork utilizing the alleyway's facades (Figure 7.11). This intervention will hopefully inspire the use of other alleys in Chinatown as community gathering spaces.

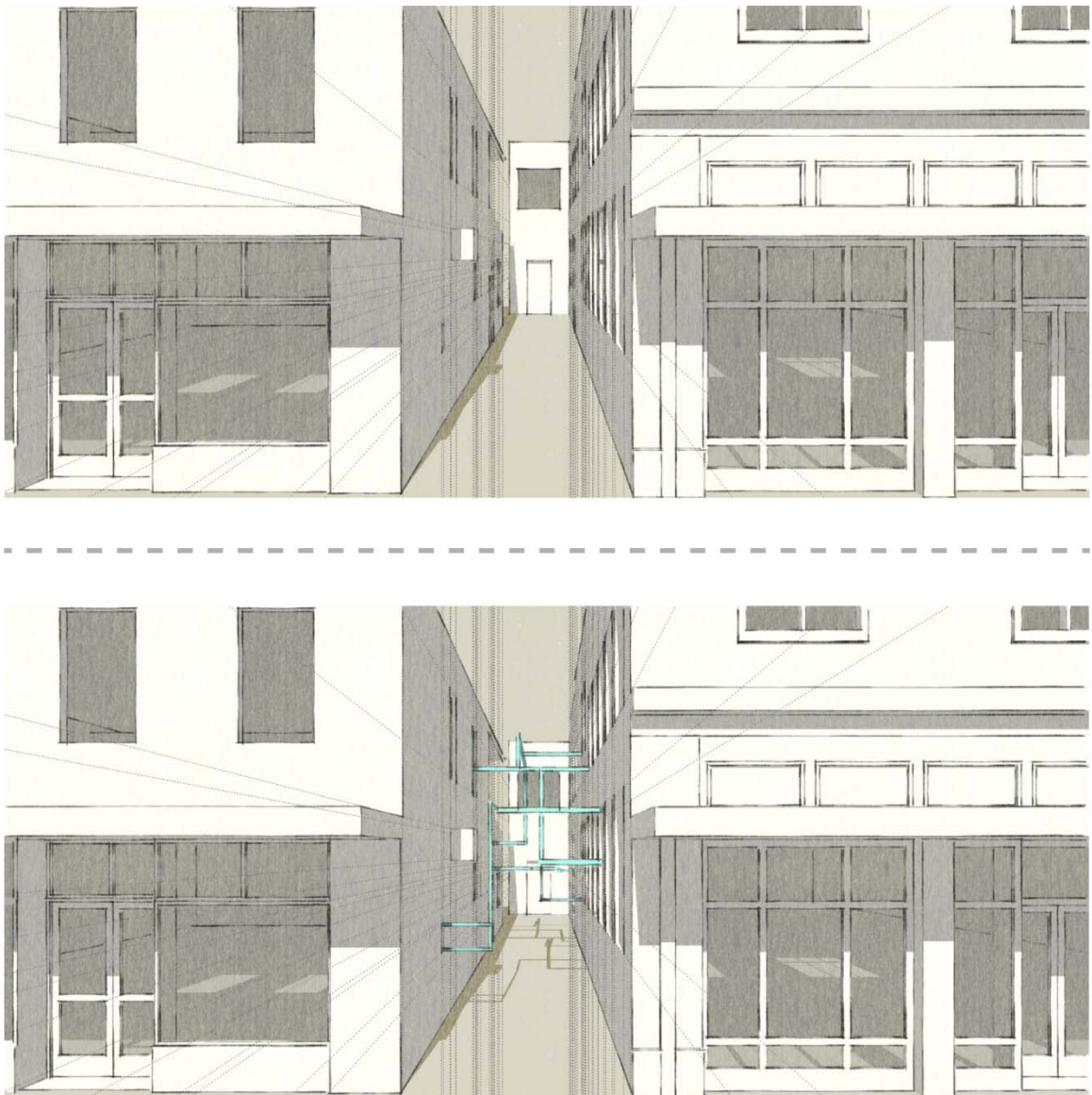

Figure 7.10 Utilizing the alley's facade to support artwork for 1st Friday Art Walk



Figure 7.11 1st Friday Art Walk Renderings

## 8 PROJECT CONCLUSION

This doctoral project showcases the potential for successful utilization of alleyways as community use spaces. Analysis of existing research led to the development of several guidelines to assist in the evaluation of alleyways and the identification of their unique characteristics and site-specific qualities for the determination of appropriate transformable interventions. The "Site Criteria Guideline" and the "Site Analysis Guideline" were applied to study and understand an alleyway's contextual information. Through a series of specified criteria and macro and micro scale context analysis, the guidelines helped narrow down the project focus to Low-Rise Mixed-Use communities and highlighted the characteristics of alleyways that were subsequently employed to generate site-specific installations. The "User + Community Events Matrix" that was developed informed the reprogramming of the alleys by incorporating existing community events within a chosen site. The essential asset of the guidelines is their applicability to any alleyway condition.

In creating an installation for the chosen alley in Honolulu's Chinatown district, the biggest indicator in the placement of the telescopic tube structures was the design of the facade. The facade also helped to support the structure of the installation; therefore, the location of the openings within the facade was crucial in determining the layout of the proposed intervention. Since no two alleys are alike, this allowed for diverse design solutions befitting to each alleyway. The reliance of the installation on the existing makeup of the alleyway facade highlights the importance of the alley's facade for site-specific design.

With growing urban environments and the need for more space, this project demonstrates how a simple installation can transform neglected alleyways into areas of rich culture and community activity. Numerous alleyways exist in various urban settings; therefore, utilizing these spaces helps to reclaim the alleyways and create usable public spaces.

---

## BIBLIOGRAPHY

Berger, Alan. *Drosscape: Wasting Land in Urban America*. New York: Princeton Architectural Press, 2006.

Chicago Department of Transportation. "The Chicago Green Alley Handbook." 2010. Accessed October 8, 2012.  
[http://www.cityofchicago.org/dam/city/depts/cdot/Green\\_Alley\\_Handbook\\_2010.pdf](http://www.cityofchicago.org/dam/city/depts/cdot/Green_Alley_Handbook_2010.pdf).

Chinatown Community Development Center, and San Francisco Department of Public Works. *Chinatown Alleyway Master Plan*. Report. Vol. 1. San Francisco, 1998.

Clay, Grady. *Alleys: A Hidden Resource*. Louisville: Grady Clay and Company, 1978.

Fialko, Mary, and Jennifer Hampton. *Seattle Integrated Handbook: Activating Alleys for a Lively City*. Seattle, 2011.

Ford, Larry. *The Spaces between Buildings*. Baltimore, MD: Johns Hopkins University Press, 2000.

Honolulu Department of Land Utilization. *Chinatown: Special District Design Guidelines*. Honolulu: Department of Land Utilization, City and County of Honolulu, 1991.

Info Grafik Inc. "Chinatown's Beginnings." Hawaii History. 2012. Accessed April 12, 2012.  
<http://www.hawaiihistory.org/index.cfm?fuseaction=ig.page>.

Kronenburg, Robert. *Flexible: Architecture That Responds to Change*. London: Laurence King Publishing, 2007.

Kronenburg, Robert. *Portable Architecture: Design and Technology*. Basel: Birkhäuser, 2008.

Marshall, Stephen. *Streets & Patterns*. London: Spon Press, 2005.

San Francisco Planning Department. "Chinatown Area Plan." San Francisco General Plan: Chinatown. July 6, 1995. Accessed March 17, 2013. [http://www.sf-planning.org/ftp/general\\_plan/Chinatown.htm](http://www.sf-planning.org/ftp/general_plan/Chinatown.htm).

Stenning, Liz, and Nikki Somers. "Alley Event Handbook." Alley Network Project. 2012. Accessed March 2, 2013. <http://alleyenetworkproject.com/wp-content/uploads/2012/03/Alley-Handbook-webpress.pdf>.

Trancik, Roger. *Finding Lost Space: Theories of Urban Design*. New York: Van Nostrand Reinhold, 1986.

Winslow, David. "Living Alleys: A New View of Small Streets." Linden Living Alley. Accessed January 17, 2013. <http://lindenlivingalley.wordpress.com/living-alleys-a-new-view-of-small-streets/>.

---

## LIST OF FIGURES

### 0 Introduction

- 0.1 Mitchell, Ria Lyn. "Project Breakdown." 2013.

### 1 Context: Macro + Micro

- 1.1 Ford, Larry. *The Spaces between Buildings*. Baltimore, MD: Johns Hopkins University Press, 2000. 71, 77, 185.
- 1.2 Trancik, Roger. *Finding Lost Space: Theories of Urban Design*. New York: Van Nostrand Reinhold, 1986. 98.
- 1.3 Jacobs, Allan. "Urban Fabric & Form Comparison." *Bricoleurbanism*. 1995. Accessed March 8, 2012. <http://www.bricoleurbanism.org/whimsicality/urban-fabric-form-comparison/>.
- 1.4 (a) Maki, Fumihiko. *Investigations in Collective Form*. St. Louis: School of Architecture, Washington University, 1964. 12.  
(b) Marshall, Stephen. *Streets & Patterns*. London: Spon Press, 2005. 136.
- 1.5 Cullen, Gordon. *Townscape*. New York: Reinhold Publishing Corporation, 1961. 17.
- 1.6 Fialko, Mary, and Jennifer Kempson. *Seattle Integrated Alley Handbook: Activating Alleys for a Lively City*. Seattle, 2011. 16-17.

### 2 Social: Community + Use

- 2.1 Fialko, Mary, and Jennifer Kempson. *Seattle Integrated Alley Handbook: Activating Alleys for a Lively City*. Seattle, 2011. 20-23.
- 2.2 Chicago Department of Transportation. "The Chicago Green Alley Handbook." 2010. Accessed October 8, 2012. [http://www.cityofchicago.org/dam/city/depts/cdot/Green\\_Alley\\_Handbook\\_2010.pdf](http://www.cityofchicago.org/dam/city/depts/cdot/Green_Alley_Handbook_2010.pdf).

- 2.3 (a) Martin, Justin. "Alley Enterprise Zones." SvR Design Posts. April 29, 2010. Accessed September 6, 2012. <http://www.svrdesign.com/blog/author/justin/>.
- (b) Green Garage. "Green Alley Project." GreenGarageWiki. July 10, 2012. Accessed September 6, 2012. [http://greengaragedetroit.com/index.php?title=Green Alley Project](http://greengaragedetroit.com/index.php?title=Green_Alley_Project).
- (c) Pomegranate Center. "Sumner Mainstreet Alley Project." Pomegranate Center News RSS. Accessed September 6, 2012. <http://www.pomegranatecenter.org/build-community/sumner-mainstreet-ally-project/>.
- 2.4 (a) Archinect. "Need More Office Space? Just Stick Some in the Alley." Archinect News. April 10, 2012. Accessed September 14, 2012. <http://archinect.com/news/tag/91940/alleys>.
- (b) Zimmer, Lori. "Keret House: Warsaw's Narrowest Home Will Be Set Within This Tiny Alley." Inhabitat. July 22, 2011. Accessed September 28, 2012. <http://inhabitat.com/keret-house-warsaws-narrowest-home-will-be-set-within-this-tiny-alley/>.
- (c) Wilson, Mark. "Alley House Brings Luxury Living to Cockroach Cracks." Gizmodo. May 9, 2008. Accessed September 18, 2012. <http://gizmodo.com/389023/alley-house-brings-luxury-living-to-cockroach-cracks>.
- (d) Kawata, Hiroki. "Ogimachi Global Dispensing Pharmacy by TKY Japan." Dezeen RSS. January 30, 2012. Accessed September 28, 2012. <http://www.dezeen.com/2012/01/30/ogimachi-global-dispensing-pharmacy-by-tky-japan/>.
- 2.5 (a) Mejia, Lisette. "Exploring the Mission's Tourism Business." Mission Local. July 31, 2012. Accessed February 07, 2013. <http://missionlocal.org/2012/07/exploring-the-missions-tourism-business/>.
- (b) Kleinfeld, Abe. "Murals of San Francisco's Mission District." Welcome to Abe's Web Site. March 2005. Accessed February 07, 2013. <http://www.abekleinfeld.com/mission-district-murals-3-05.htm>.
- (c) Tobianski, Joseph. "New Mural Gracing Wall of Liberty Street Alley." AnnArbor.com. October 24, 2012. Accessed February 07, 2013. <http://www.annarbor.com/entertainment/new-mural-gracing-wall-of-liberty-street-alley/>.

- 2.6 (a) Seattlealleys. "World Cup Alley 2." Alleys of Seattle Blog. June 12, 2010. Accessed September 6, 2012. <http://alleysofseattle.com/2010/06/12/world-cup-alley-2/>.
- (b) Poling, Mira, and Alyse Nelson. "Alley, Alley, in Come Free." Sightline Daily. August 26, 2011. Accessed March 2, 2013. <http://daily.sightline.org/2011/08/26/alley-alley-in-come-free-2/>.
- (c) Fleisher, Sid. "Alley Improvement Project." Troy Alley Action. 2006. Accessed March 4, 2013. [http://www.troyalleyaction.org/pdf/AlleyProject2006TroyNY\\_.pdf](http://www.troyalleyaction.org/pdf/AlleyProject2006TroyNY_.pdf).
- 2.7 Stenning, Liz, and Nikki Somers. "Alley Event Handbook." Alley Network Project. 2012. Accessed March 2, 2013. <http://alleynetworkproject.com/wp-content/uploads/2012/03/Alley-Handbook-webpress.pdf>.

### 3 Site: Chinatowns

- 3.1 (a) Fodor's Editors. "Best Dim Sum in San Francisco's Chinatown." Fodor's Travel Intelligence. October 13, 2010. Accessed February 9, 2013. [http://www.fodors.com/news/story\\_4243.html](http://www.fodors.com/news/story_4243.html).
- (b) Made Healthier. "Dim Sum at Legends in Honolulu." Made Healthier. 2008. Accessed February 9, 2013. <http://madehealthier.com/2008/11/07/dim-sum-legends-honolulu/>.
- 3.2 San Francisco Planning Department. "Chinatown Area Plan." San Francisco General Plan: Chinatown. July 6, 1995. Accessed March 17, 2013. [http://www.sf-planning.org/ftp/general\\_plan/Chinatown.htm](http://www.sf-planning.org/ftp/general_plan/Chinatown.htm).
- 3.3 (a) Chinatown Community Development Center, and San Francisco Department of Public Works. *Chinatown Alleyway Master Plan*. San Francisco, 1998. 12.
- (b) *Chinatown Alleyway Master Plan*. 15.
- 3.4 *Chinatown Alleyway Master Plan*. 19.
- 3.5 (a) Hawaiian Government Survey. "Honolulu and Vicinity 1887." Map. In *Maps from University of Hawai'i at Manoa*. Accessed March 12, 2013. <http://digicoll.manoa.hawaii.edu/savedmaps/Pages/viewtext.php?s=browse>.
- (b) Google, and Sanborn. "Chinatown Honolulu." Google Maps. March 2013. <https://maps.google.com/maps?hl=en>.



3.6 Info Grafik Inc. "Chinatown's Beginnings." Hawaii History. 2012. Accessed April 12, 2012. <http://www.hawaiihistory.org/index.cfm?fuseaction=ig.page>.

3.7 (a) & (b) Honolulu Department of Land Utilization. *Chinatown: Special District Design Guidelines*. Honolulu: Department of Land Utilization, City and County of Honolulu, 1991. 12-13.

#### 4 Material Study: Transformable Systems

4.1 Mitchell, Ria Lyn. "Transformable System Typology." 2012.

4.2 Atkore International Inc. *Unistrut Catalog*. Chicago, 2011. 57-59, 63.

4.3 Atkore International Inc. *Unistrut: General Engineering Catalog No. 17*. Chicago, 2011. Accessed April 2, 2013. 23, 57.

[http://eberliron.com/public/files/Literature/Unistrut/Unistrut\\_GenEngCat17.pdf](http://eberliron.com/public/files/Literature/Unistrut/Unistrut_GenEngCat17.pdf).

Ultra Built Industries Inc. "Tube Telescoping." Ultra Built Industries. Accessed April 2, 2013. [http://www.ultrabuilt.net/products/subpages.php?cat=Tube\\_Telescoping](http://www.ultrabuilt.net/products/subpages.php?cat=Tube_Telescoping).

4.4 Atkore International Inc. *Unistrut Catalog*. Chicago, 2011. 58-59.

#### 5 Existing Knowledge Conclusion

5.1 Mitchell, Ria Lyn. "Site Criteria Guideline." 2013.

5.2 Mitchell, Ria Lyn. "Site Analysis Guideline." 2013.

5.3 Mitchell, Ria Lyn. "Example of User + Community Events Matrix." 2013.

5.4 Mitchell, Ria Lyn. "Intrinsic Alleyway Characteristics." 2013.

#### 6 Implementation: Honolulu Chinatown Alleys

6.1 Google, and Sanborn. "Chinatown Honolulu." Google Maps. March 2013. <https://maps.google.com/maps?hl=en>.

- 6.2 Mitchell, Ria Lyn. "Void + Unused Spaces." 2012.
- 6.3 Mitchell, Ria Lyn. "Circulation + Street Types + Alleyway Locations." 2013.
- 6.4 Mitchell, Ria Lyn. "Alley Locations." 2013.
- 6.5 Mitchell, Ria Lyn. "Alleyways + Community Events." 2013.
- 6.6 Mitchell, Ria Lyn. "Chinatown Alleyway Catalog." 2013. Images from Google Earth.
- 6.7 Mitchell, Ria Lyn. "Rendering of chosen site." 2013.
- 6.8 Mitchell, Ria Lyn. "Chosen site context." 2013. Images from Google Earth.
- 6.9 Mitchell, Ria Lyn. "Panoramic views of alley and surrounding context." 2013.
- 6.10 Mitchell, Ria Lyn. "Grid pattern of east and west facade." 2013.
- 6.11 Mitchell, Ria Lyn. "Rendering of alley's west facing facade." 2013.
- 6.12 Mitchell, Ria Lyn. "Rendering of alley's east facing facade." 2013.

## 7 Design Proposals

- 7.1 Mitchell, Ria Lyn. "User + Chinatown Community Events Matrix." 2013.
- 7.2 Mitchell, Ria Lyn. "Basic Horizontal Surfaces + Heights." 2012.
- 7.3 Mitchell, Ria Lyn. "Alley Facade Grid + Horizontal Surface Heights." 2013.
- 7.4 Mitchell, Ria Lyn. "Utilizing the alley's facade to support a canopy installation." 2013.
- 7.5 Mitchell, Ria Lyn. "Canopy Structural Components." 2013.
- 7.6 Mitchell, Ria Lyn. "Canopy Rendering." 2013.

- 7.7 Mitchell, Ria Lyn. "Utilizing the alley's facade to support a farmer's market." 2013.
- 7.8 Mitchell, Ria Lyn. "Farmer's Market Structural Components." 2013.
- 7.9 Mitchell, Ria Lyn. "Farmer's Market Rendering." 2013.
- 7.10 Mitchell, Ria Lyn. "Utilizing the alley's facade to support artwork for 1st Friday." 2013.
- 7.11 Mitchell, Ria Lyn. "1st Friday Art Walk Renderings." 2013. Artwork Sources:  
*First Fridays.* [http://streetjamzwerkout.blogspot.com/2011\\_10\\_01\\_archive.html](http://streetjamzwerkout.blogspot.com/2011_10_01_archive.html).  
*Surf-Riders.* <http://vanitasmagazine.blogspot.com/2011/10/tc-ticky-tacky.html>.  
*Honolulu Oahu Hawaii Seascape Waterfront.*  
<http://fineartamerica.com/featured/honolulu-oahu-hawaii-seascape-waterfront-sharon-mick.html>.  
*Stock Footage Downtown Honolulu.* <http://footage.shutterstock.com/clip-3135328-stock-footage-downtown-honolulu-artwork-video-illustration.html>.