

The effects of connected lighting on lighting controls and design

by

Nicole Tan Sabourin

B.S., Kansas State University, 2017

A REPORT

submitted in partial fulfillment of the requirements for the degree

MASTER OF SCIENCE

Department of Architectural Engineering and Construction Science
College of Engineering

KANSAS STATE UNIVERSITY
Manhattan, Kansas

2017

Approved by:

Major Professor
Fred Hasler

Copyright

© Nicole Sabourin 2017.

Abstract

The Internet of Things (IoT) is rapidly growing and is starting to be incorporated into commercial buildings. One of the ways that the IoT is being used in buildings is connected lighting, also referred to as smart lighting. Connected lighting allows for communication between the lighting system, people, the environment, and other devices. This paper will focus on connected lighting and its effect on lighting controls and design.

The IoT is expected to see substantial growth in the next few years and the growth of connected devices will have a huge impact on the lighting industry as connected lighting systems will be installed in more commercial buildings. The shift to solid state lighting (SSL) in recent years has brought the transition from conventional lighting controls to connected lighting controls. For this shift to be successful, issues with interoperability, security and reliability will need to be overcome.

Connected lighting systems on the market are using both wired and wireless technologies. Power over Ethernet (PoE) and wireless technologies such as ZigBee and Bluetooth Smart are currently being incorporated into connected lighting systems. The introduction of these technologies is changing the way that lighting control systems are designed and installed. Products such as fixture-integrated sensors and wireless devices are also being used in connected lighting systems. These products, along with the wired and wireless technologies, are changing lighting control system configurations.

Lighting design will also be affected by connected lighting systems. New features including color-tunability and indoor positioning will be used to enhance the lighting system and improve occupant health. Also, energy code compliance will be easier since connected lighting controls will be mostly software-based and can be reprogrammed. Connected lighting systems

will be integrated into other building systems such as heating, ventilating, and air conditioning systems or security systems and will also be used in a variety of applications. Connected lighting systems will greatly affect both lighting controls and design of lighting control systems. This paper introduces connected lighting and is intended for those who are not familiar with its design, applications, and implementation.

Table of Contents

List of Figures	viii
List of Tables	ix
Acknowledgements	x
Dedication	xi
Chapter 1 - Introduction.....	1
Chapter 2 - Lighting Control Strategies and Current Products.....	5
Dimming	5
Occupancy Control	6
Daylight Harvesting	7
Time Control.....	8
Chapter 3 - Transition to Connected lighting	9
Market Trends.....	9
Shift to Connected Lighting.....	13
Key Challenges	14
Interoperability	14
Security	16
Reliability.....	17
Chapter 4 - Connected Lighting.....	19
Common Wireless Technologies	19
Wi-Fi	22
Bluetooth Smart	23
ZigBee.....	24

Z-Wave	25
Thread	25
EnOcean	26
Power over Ethernet (PoE)	26
Summary	27
Chapter 5 - Connected Lighting Effects on Lighting Controls	29
Adoption of Lighting Control Systems	29
Products	30
System Configuration	32
Conventional Lighting Control Systems	33
Connected Lighting Control Systems	35
Control Approaches for Luminaires with Integrated Sensors	35
Examples of Connected Lighting Systems	37
Chapter 6 - Connected Lighting Effects on Lighting Design	40
Features	40
Color-Tunability	41
Indoor Positioning	42
Energy Code Compliance	43
Wiring	44
Integration into Building Systems and Potential Applications	45
Chapter 7 - Case Studies	47
The Edge	47
Carrefour Market	49

Chapter 8 - Conclusion	50
References.....	52
Appendix A - Permissions and Disclaimers	55

List of Figures

Figure 1.1: Projected Number of Connected Devices Until 2022	1
Figure 3.1: Installed Stock Projections of Light Sources Until 2035	11
Figure 3.2: Lighting Controls for LEDs vs. Conventional Lighting.....	13
Figure 3.3: Throughput vs. Distance.....	17
Figure 4.1: Open System Interconnection (OSI) Model: a) OSI Model and b) Simplified OSI Model	20
Figure 4.2: Network Topologies	22
Figure 5.1: Typical Arrangement of Lighting Control System.....	33
Figure 5.2: Wiring Diagram for a Typical Lighting Control System	34
Figure 5.3: Central Control Approach	35
Figure 5.4: Distributed Control Approach	36
Figure 5.5: Connected Lighting System Configuration with PoE Technology and Luminaire- Integrated Sensors	38
Figure 5.6: Connected Lighting System Configuration with PoE Technology and Stand-alone Sensors and Controls.....	39

List of Tables

Table 3.1: Installed Stock Penetration of Lighting Controls in 2015	12
Table 4.1: Summary of Wireless Technology Characteristics.....	28
Table 6.1: Future ANSI/ASHRAE/IES Standard 90.1 Energy Savings Compared to Previous Versions	43

Acknowledgements

I would first like to thank my major professor Fred Hasler for his support and guidance throughout my years of study and the writing of this report. I would also like to acknowledge the members of my committee, Ray Yunk and Don Phillippi for their time and valuable comments on this report.

Additionally, I would like to express my thanks to my family and friends for their continuous support. I especially thank my parents, James and Christine, and my brother, Ken, for their encouragement. Finally, I must express my gratitude to Aaron Swaney for his input on this report and supporting me throughout my college career.

Dedication

I would like to dedicate this report to my family and Aaron Swaney.

Chapter 1 - Introduction

Emerging technology over the past several years has led to a new phrase that seems to be everywhere, the Internet of Things (IoT). This phrase refers to numerous devices that are connected to the internet and are used for monitoring and control in a variety of different applications. IoT “things” include various devices such as smart phones, wearable devices, thermostats, and appliances. The number of these devices is expected to grow very rapidly over the next few years.

Ericsson, a leader in information and communication technology, predicts that there will be about 29 billion connected devices worldwide by 2022 (Ericsson, 2016). Figure 1.1 shows the projected number of connected devices in the next five years. Ericsson categorizes IoT devices into two groups, short-range and wide-area. “The short-range segment consists of devices connected by unlicensed radio with a typical range of up to around 100 meters, such as Wi-Fi, Bluetooth and Zigbee. The wide-area category consists of devices using cellular

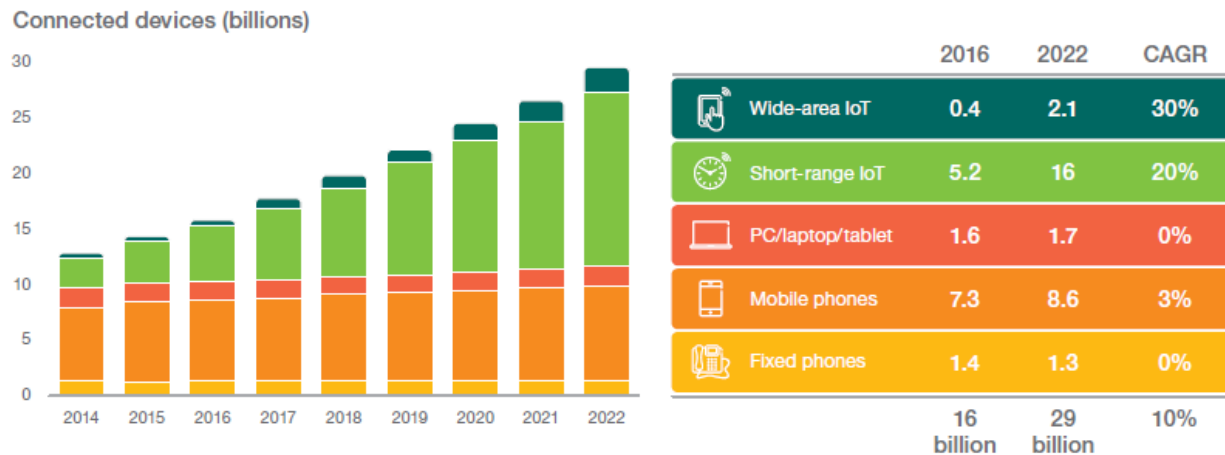

¹ In our forecast a connected device is a physical object that has an IP stack, enabling two-way communication over a network interface. Traditional landline phones are included for legacy reasons

² Connected devices connecting to a wide-area network through a common gateway

Figure 1.1: Projected Number of Connected Devices Until 2022

From “Ericsson Mobility Report,” (p. 33), by Ericsson, 2016.

connections ... as well as unlicensed low-power technologies, such as Sigfox, LoRa and Ingenu” (Ericsson, 2016, p. 33). These technologies are all being used for IoT device connectivity.

As shown in Figure 1.1, wide-area and short-range IoT devices show the most growth and have a relatively large compound annual growth rate (CAGR). This value gives the average growth rate of connected devices between 2014 and 2022. PCs, laptops, tablets and fixed phones are not expected to grow at all and mobile phones are only expected to grow by 3%. The growth of IoT devices will influence the market and encourage manufacturers to pursue more research and development of IoT devices. This will result in better communication, operability and security of connected devices. New applications and functions will be realized as the IoT is developed.

The potential of having billions of connected devices will impact several different industries including city planning and building design. Smart, connected devices will allow data to be gathered on aspects such as water usage, power usage and traffic patterns. With the implementation of more smart devices, city planning and decision-making will greatly improve. However, with the many benefits that smart cities offer, there remain several challenges in the implementation of these cities. While previous predictions have estimated wide-spread adoption of smart cities within the next five years, more recent information suggests that it may take closer to ten to fifteen years. The reason for this delay is the realization that more infrastructure and resources will be required than originally anticipated (Black & Veatch Insights Group, 2016).

A large part of implementing smart cities will be to construct smart buildings. Smart buildings are being constructed with thousands of sensors to collect data from building systems such as lighting, HVAC, plumbing, and security systems. These sensors can monitor several

characteristics of a space including occupancy and temperature. Data collection from individual buildings allows for better planning and understanding of city demands. With the multitude of applications in the IoT, the focus of this report has been narrowed to connected lighting.

Connected lighting, also referred to as smart lighting or adaptive lighting, stems from the idea that lighting can communicate with the environment, building occupants, and other devices. IoT is emerging as the way of the future and is creating a demand for connected lighting so that light fixtures can be integrated with other things. These things include but are not limited to smartphones, HVAC systems, fire protection systems and security systems. Communication with smartphones can be used to control individual luminaires based on user preference. Connected lighting systems may provide occupancy data, CO₂ levels, and temperature readings to other building systems. For example, occupancy data can be used to regulate HVAC systems and turn off unnecessary equipment to reduce energy use.

This report will first discuss four automatic lighting control strategies and current products used to carry out these strategies. The transition to connected lighting and the market trends for both solid state lighting (SSL) and lighting control systems will then be discussed. The shift to connected lighting systems stems from the valuable features and benefits that they can provide, however, there will be several key challenges that need to be overcome before connected lighting systems can be more widely implemented.

Connected lighting systems are fairly new to the market and several technologies are being implemented in the various lighting systems. Connectivity between sensors and luminaires is provided by both wired and wireless systems based on the manufacturer that is used. As connected lighting systems are developed, lighting controls and considerations for design will change. Some of the major effects of connected lighting on controls include the

adoption rate of control systems and products that are used. Moreover, the use of different products alters lighting control system configurations. Connected lighting will affect lighting design with new features and wiring schemes. Connected lighting systems may be easily configured to meet energy code requirements and will be integrated into other building systems.

Chapter 2 - Lighting Control Strategies and Current Products

There are four main automatic lighting control strategies used in commercial buildings: dimming, occupancy control, daylight harvesting and time control. These strategies are used to provide different lighting schemes, increase energy efficiency and comply with energy codes. Sensors and manual override switches are typically used to switch luminaires on/off or dim the luminaires. Luminaires are assigned to different zones, or areas of controls to maximize the use of the different lighting control strategies.

Dimming

Dimming is used to control the light output of a lamp and provide varying illumination levels in a space. This type of control is more expensive than basic on/off switching because of the additional cost of dimming components such as dimming ballasts for fluorescents and dimming drivers for LEDs. Dimming is used in spaces where flexibility is important and different scenes need to be created. Scenes are important in spaces where different tasks are performed throughout the day or event, such as restaurants, conference rooms, or classrooms (IESNA Handbook, 2011). Stand-alone dimming control is accomplished via wall-mounted switches programmed to provide different light levels with scene buttons or dimming buttons. Each switch can typically have up to eight buttons, each programmed to provide a different scene, or light level. Dimming is typically not used as a stand-alone automatic lighting control strategy in commercial buildings as they are used as part of the control strategies discussed in the following sections.

Occupancy Control

Occupancy and vacancy sensors are used to control luminaires based on the presence of people and are often used to comply with energy codes. Although the sensors have similar function, there is a slight difference between the two. Occupancy sensors automatically turn luminaires on when it senses an occupant and off when the room becomes vacant. Vacancy sensors require that luminaires be manually switched on and automatically turned off when there is no one there. Both types of sensors have a manual override so that luminaires can be switched on or off based on the preference of the occupants. Occupancy and vacancy sensors are required in many types of spaces and are especially useful in transient spaces where people come and go often. Vacancy sensors may be used instead of occupancy sensors to comply with energy codes that have very specific requirements. For the rest of this paper, both types of sensors will be referred to as occupancy sensors.

Occupancy sensors use two different technologies, passive infrared and ultrasonic, but a combination of both is also used. They are available in three mountings: wall mounted, ceiling mounted and integral to the switch. The mounting type is selected based on the coverage that is provided by each type. Coverage patterns are provided by the manufacturer and show how much area can be covered with a single sensor. The time delay of the occupancy sensor controls how long the lighting will be on before it is automatically turned off. This setting can be adjusted within a range of about one to thirty minutes depending on the specific product.

Daylight Harvesting

Daylight harvesting is an important aspect of lighting design and controls are often used to perform this operation. Daylight harvesting is used to take advantage of available daylight and adjust the amount of electric lighting used to provide sufficient light levels in a space. It is often used in conjunction with occupancy sensors to provide further energy savings or meet code requirements.

Daylight harvesting is typically accomplished by switching luminaires off or by dimming. The simpler approach is to switch the luminaires off when a certain light level is reached and switch the luminaires back on when the levels fall below a minimum value (Silvair, 2016). The other approach is to use dimming to provide appropriate ambient light levels based on the amount of daylight available. This method uses photosensor data to regularly adjust the lumen output of the luminaires based on the readings and will maintain a fixed illumination level throughout the day. To take advantage of all available daylight, luminaires are typically zoned based on their distance from sources of daylight such as windows and skylights so that the luminaires closest to these fenestrations can be controlled separately than those farther away.

Photosensors are ceiling-mounted and are used to detect ambient light levels. A microprocessor in the photosensor uses a control algorithm to convert this reading and send it as a control signal to dim or switch off luminaires accordingly. In a closed-loop system, the photosensors measure both the electric light and daylight when determining the ambient light levels in the space. Open-loop systems only measure the amount of daylight that is available (Silvair, 2016).

Time Control

Time control is accomplished by timers that are used to schedule when luminaires will be turned on and off. This type of lighting control strategy is much simpler to implement than occupancy controls and daylight harvesting since sensors are not required (Silvair, 2016). Time-of-day controls are used when the space is used during the same time every day and there is little to no deviation from the schedule. For example, these controls might be used in an open office where there is a set schedule and at least one person is there during this schedule, eliminating the usefulness of occupancy controls. Manual overrides are required to turn the luminaires on and off outside of the scheduled time. Time-of-day controls are typically less expensive than occupancy controls since there are no sensors required in the space. Also, time controls are much simpler than occupancy controls or daylight harvesting. The timer can be part of a wall-mounted switch or contained in a lighting control panel that is connected to the luminaires via low voltage cabling.

Chapter 3 - Transition to Connected lighting

The transition from traditional lighting systems to connected lighting systems is a huge endeavor, however, connected lighting has the potential to provide features and benefits that are not obtainable with traditional lighting control systems. Part of the push to connected lighting comes from the increasing popularity of LEDs since they are extremely controllable and can be integrated with sensors and processors more easily and at a lower cost than other available light sources (DOE Solid-State Lighting Program, 2016). As with any change, there are several key challenges that need to be overcome before connected lighting can be implemented more widely and in a way that takes advantage of potential benefits. The key challenges discussed are interoperability, security and reliability. As these challenges are overcome and more LEDs are installed, connected lighting systems will be installed in more commercial buildings.

Market Trends

Solid state lighting has been developing very rapidly since the United States Department of Energy (DOE) started to push this technology in 2000 by supporting SSL research and development (DOE Solid-State Lighting Program, 2016). The DOE has a Solid-State Lighting Program that has been working with the lighting industry to develop SSL technology. SSL is based on LEDs that create light using a semiconductor. The first LEDs used for lighting were red diodes invented in 1962, followed by pale yellow and green diodes. Improvements of red LEDs led to their use in calculators and as indicator lights, but the invention of blue and white LEDs led to their use in several applications such as traffic lights and televisions (U.S. Department of Energy Building Technologies Office, 2013). The use of white LEDs in general lighting was then anticipated as long as they could be improved. In 2006, white LEDs had a luminous efficacy of less than 20 lm/W, similar to the efficacy of incandescent lamps (U.S.

Department of Energy, 2017). The efficacy is a measure of how much power is used to produce a certain number of lumens. LEDs have improved immensely over the years and now have a much higher efficacy than they used to. Many LEDs have efficacies greater than 160 lm/W and the highest has an efficacy of 209 lm/W (U.S. Department of Energy, 2017).

LEDs have numerous advantages over conventional light sources, but LEDs are mostly known for their relatively high luminous efficacy and long life. A high efficacy decreases lighting operating costs and the long life leads to fewer lamp replacements over the life of the building. Fewer lamp replacements reduce maintenance costs since maintenance staff will not need to spend a lot of time replacing lamps. LEDs have the advantage of better controllability since frequent on/off cycling and dimming has no effect on the performance or life of the LED. Also, they are easily integrated into lighting controls.

Although LEDs have many advantages over other light sources, they have a higher first cost as compared to other light sources such as incandescent or fluorescent lamps. The DOE estimates that only 6.4% of U.S. installations were LED-based in 2015 (SSL R&D Plan). The price of LED lamps has dropped over 85% since 2008 and as a result, the installation of LEDs is increasing (Moniz, 2013).

Figure 3.1 shows the projection of installed stock, or the number of units installed, for different light sources over 20 years. This figure presents the number of installed units for each light source type in millions of units, where a light fixture and its components including ballasts and lamp(s) are one unit. In 2035, LEDs will make up about 86% of the total installed lighting stock (Navigant Consulting, 2016). The longevity of LEDs is having a huge effect on the lighting market, which is now focusing on providing feature-packed control systems to make up for the decreasing number of lamps being sold (Seed Labs, 2015). The increased installation of

LEDs in commercial buildings has led to connected lighting, further increasing energy efficiency and lighting control functionality.

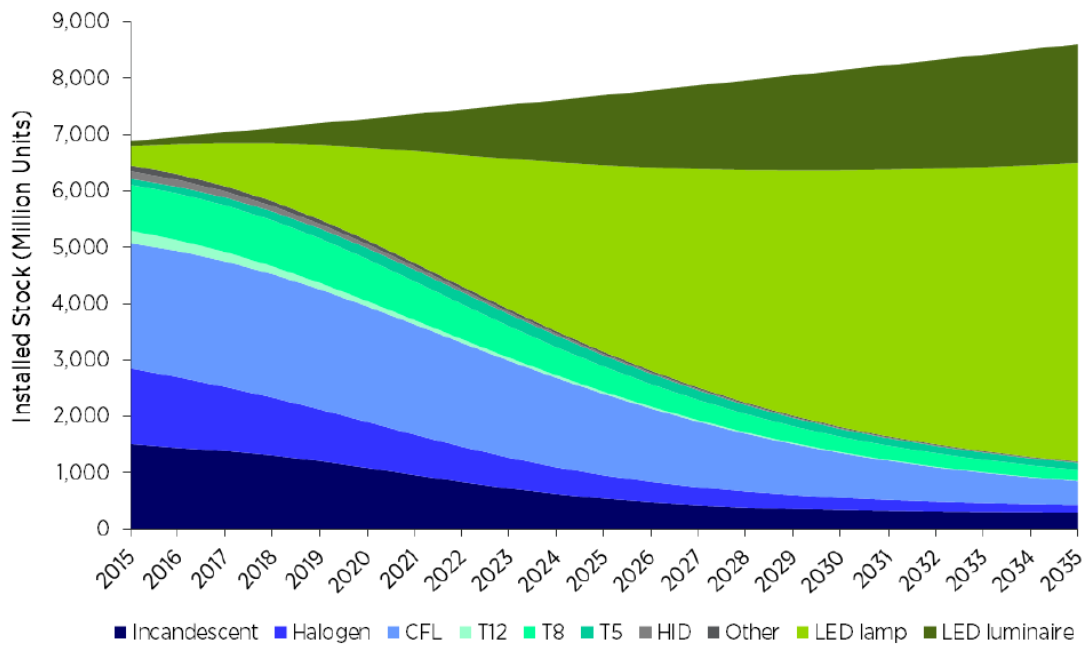

Figure 3.1: Installed Stock Projections of Light Sources Until 2035

From “Energy Savings Forecast of Solid-State Lighting in General Illumination Applications,” (p. 17), by Navigant Consulting, 2016.

Although automatic lighting controls have been on the market for years, the adoption of lighting control systems in most commercial buildings has not occurred due to their complexity, cost of design and installation, and lack of interoperability (DOE Solid-State Lighting Program, 2016). Table 3.1, which was published in the report titled *Energy Savings Forecast of Solid-State Lighting in General Illumination Applications*, shows the installed stock penetration of lighting control systems in the commercial market in 2015. This percentage represents the number of installed lighting control systems compared to the overall potential market. The report defines four traditional control strategies: dimmers, daylighting, occupancy sensors, and timers. The terms included in Table 3.1 reference these control strategies and are as follows:

- Multi – refers to combinations of two or more traditional lighting control strategies used in the same luminaire
- Energy Management Systems – refers to the control of luminaires by a system that uses all four control strategies, includes Building Management Systems (BMS)
- Connected – refers to system where there is communication between lighting products and utilizes all four lighting control strategies

Table 3.1: Installed Stock Penetration of Lighting Controls in 2015

Adapted from “Energy Savings Forecast of Solid-State Lighting in General Illumination Applications,” (p. 21), by Navigant Consulting, 2016.

Installed Stock Penetration (%)	Commercial
None	68%
Dimmer	3%
Daylighting	<1%
Occupancy Sensor	6%
Timer	4%
Energy Management Systems	15%
Multi	4%
Connected	<1%

Table 3.1 shows that most commercial buildings do not have any of the four traditional lighting control strategies in place. The installed stock penetrations of the four traditional lighting control strategies combined is only about 18%, including the multi-strategy category. The use of energy management systems makes up a relatively large portion of the installed market penetration as compared to the other categories. Connected lighting control systems has one of the lowest penetrations as they are present in less than 1% of commercial buildings.

The DOE expects that the use of lighting control systems over the next 20 years will experience substantial growth primarily due to the increased installation of LEDs and their innate compatibility with lighting controls. The DOE SSL Program has based several of their lighting

control forecasts on two different scenarios. The “Current SSL Path” assumes that connected lighting controls will be adopted at a slow rate similar to the adoption rate for occupancy sensors (Navigant Consulting, 2016). The “DOE SSL Program Goal” scenario assumes that the adoption rate of connected lighting will be much more rapid and have “the same trajectory of LED lighting” (Navigant Consulting, 2016, p. 21). The DOE hopes to have a moderate connected lighting market penetration by 2035 as shown in Figure 3.2. If their goals are met, connected LED lighting will make up almost a quarter of the market penetration.

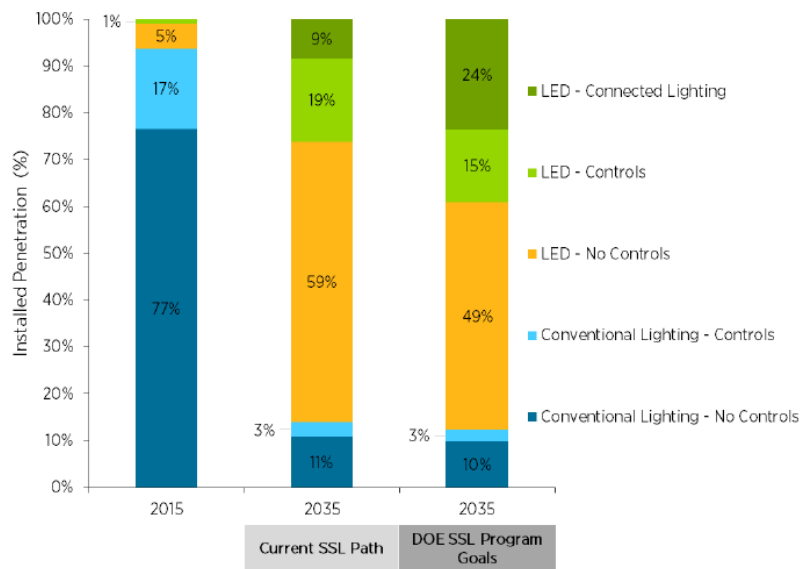

Figure 3.2: Lighting Controls for LEDs vs. Conventional Lighting

From “Energy Savings Forecast of Solid-State Lighting in General Illumination Applications,” (p. 23), by Navigant Consulting, 2016.

Shift to Connected Lighting

The shift to connected lighting is occurring because it will provide numerous advantages over current lighting controls. These include increased energy efficiency, improvements in occupant health and comfort, and increased data sharing between building systems (Mathews & Muller, 2016). Energy efficiency will be increased as connected lighting controls are more

comprehensive than conventional lighting controls. Many connected lighting solutions have wireless sensors and switches that will provide flexibility not available with wired solutions (Seed Labs, 2015). This will allow buildings to comply with updated commercial energy codes with software updates rather than going through the hassle of wiring and rewiring existing control systems. Also, many of the connected lighting systems have luminaires with integrated sensors that can be used to collect occupancy and light level data and transmit the status of the luminaire back to a management system (Seed Labs, 2015). The effects of connected lighting on lighting controls and design will be discussed in more detail in Chapters 5 and 6.

Key Challenges

Connected lighting in the IoT is introducing some major challenges and changing the way the lighting industry is approaching lighting products. The lighting industry is implementing hardware and software changes to overcome challenges with interoperability, security and reliability of connected lighting. Addressing these issues will allow the market for connected lighting to continue to expand and development of connected lighting technologies to thrive. Additionally, solving these problems will decrease the cost of a connected lighting system and increase user friendliness. Collaboration between different industries, mitigation of security threats within wireless networks, and the affirmation of reliable connected lighting systems will all need to be overcome as the connected lighting market grows and development of the IoT continues.

Interoperability

Traditional lighting control systems are proprietary and use different hardware and software to ensure that consumers will purchase an entire lighting control system consisting of sensors and controllers from the same manufacturer. The key to creating a comprehensive

network of intelligent building systems is interoperability, or the ability of devices from different manufacturers to communicate with one another. Interoperability will allow lighting sensors to share collected data with devices designed by other companies and devices used in other building systems. This will require manufacturers of these products to design around a standard protocol or platform (DOE Solid-State Lighting Program, 2016).

Several organizations such as The Connected Lighting Alliance (TCLA) and the Zigbee Alliance are trying to standardize connected lighting technology so that luminaires can be used in the future to collect and share data. TCLA is a non-profit organization that promotes the use of open standards for wireless lighting systems in both the residential and commercial lighting markets (The Connected Lighting Alliance, n.d.). TCLA sets requirements that standards should meet to accommodate lighting applications. Additionally, TCLA is analyzing existing standards to identify any differences between the standard and identified TCLA requirements. After requirements and standards are analyzed, TCLA is publishing technical papers so that industry can better understand the benefits of standards and choose the most appropriate based on individual requirements (The Connected Lighting Alliance, n.d.).

The Zigbee Alliance was established in 2002 and develops open standards. Zigbee Alliance wireless standards focus on control and sensor application as well as establishing interoperability between vastly different systems and devices (ZigBee Alliance, 2017). The adoption of these standards is intended to increase the flexibility and functionality of devices while ensuring high quality products for customers. These standards were developed by members of the Zigbee Alliance that include diverse industries and groups such as public companies, governmental regulatory groups and universities (ZigBee Alliance, 2017).

Connected lighting is still in early development and will require continued collaboration between many different industries before being widely implemented in commercial buildings.

Security

Security is another major challenge as hackers might be able to access sensitive information or even destabilize infrastructure via the wireless networks used to connect luminaires. Wireless networks typically utilize encryption to protect sensitive data and prevent unauthorized users from accessing and controlling wirelessly connected devices. Encryption is a method of converting digital data into another form that will prevent unauthorized users from being able to easily understand the information without the appropriate cypher (Rouse, 2014). The cypher will allow the transformed information to be converted back to its original form. The most common type of encryption is Advanced Encryption Standard (AES). AES originated in 1997 as a response to previous encryption methods being overcome by brute force hacking attacks that use trial and error methods to hack into vulnerable systems (Rouse, 2014). This is the most basic method of attack, however there are other methods of hacking into systems that involve either exploiting errors in system design or solving the cypher. AES remains the most popular method of encryption since it was highly publicized and scrutinized by the public to ensure the functionality of its design during its creation (Rouse, 2014).

Having a weak wireless security system with connected lighting may be harmless, but it may have severe consequences. It is possible to take complete control of a lighting system and infiltrate other systems through that network. Hackers can exploit these vulnerabilities to switch lights on and off to cause discomfort to occupants or even cause medical emergencies such as seizures (Ronen, O'Flynn, Shamir, & Weingarten, 2016). Additionally, if a wide-scale coordinated attack is planned, a group of hackers could destabilize the electric grid by

synchronously turning lights on and off in multiple buildings to create power surges (Ronen, O'Flynn, Shamir, & Weingarten, 2016). Security is a huge issue that will become more important as more buildings move to connected lighting.

Reliability

Wireless communication is less reliable as the number of obstacles and the distance between the source and destination devices increase. These issues effectively limit throughput, which is defined as the amount of data that is actually transmitted from one device to another. Throughput is different from bandwidth, which is defined as the theoretical maximum data transfer rate. The amount of throughput a device achieves can be limited by communication protocols, number of available channels and number of devices transmitting on the same channels (National Instruments, 2012). As shown in Figure 3.3, throughput begins to decrease as distance increases.

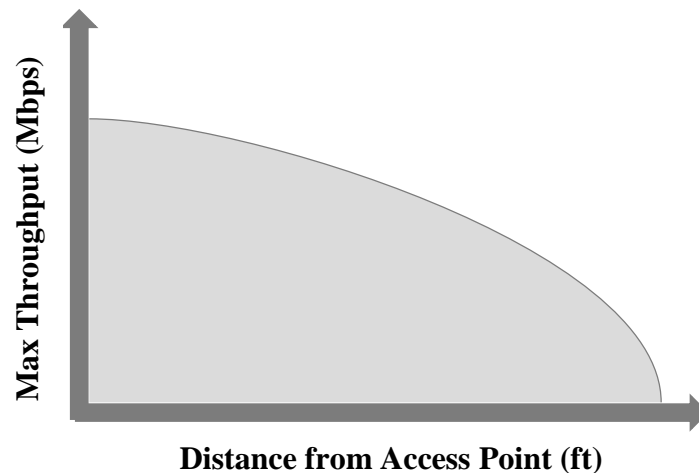

Figure 3.3: Throughput vs. Distance

Adapted from “Wireless Data Acquisition: Range versus Throughput,” by National Instruments, 2012.

Throughput is a significant consideration for connected lighting design as it can greatly affect performance. However, the future implementation of mesh networks, discussed in

Chapter 4, mitigates this issue somewhat. Since each smart luminaire communicates with the nearest smart luminaire to create a mesh nodal network, the distance and throughput loss is limited. Obstacles will similarly reduce data transfer rate, but the arrangement of connected luminaires can help mitigate this issue. If the issue of throughput loss is not adequately addressed, smart devices will begin to react sluggishly to instructions or may not respond at all.

Interference also has a large effect on data transfer. There are multiple types of interference. Anything that broadcasts a radio frequency (RF) can cause interference and ultimately data transfer loss (Anritsu Company, 2011). With the increased use of connected lighting and other smart building systems, there will be an increase in the number of unlicensed signals that may interfere with wireless communication. This will present a significant challenge as the installation of numerous wireless systems may cause interference that will inhibit smart light function.

Chapter 4 - Connected Lighting

Connected lighting uses the same automatic lighting control strategies discussed in Chapter 2, but allows for communication to exist between luminaires, their environment, occupants, and other devices. Residential connected lighting has taken off in the past few years, however, it is unsure where the commercial connected lighting market is heading. Since lighting is everywhere, data can be collected via the lighting system for entire buildings and can provide useful information to control other systems in the building. For this reason, connected lighting has the potential to be the backbone of the IoT (DOE Solid-State Lighting Program, 2016). Furthermore, connected lighting can improve the well-being of occupants and sensors can be used to make lighting adapt to the surroundings on a more individual level.

Although connected lighting systems will have many of the same products, the technology used in the proprietary systems vary. Manufacturers are creating proprietary systems with both wired and wireless technologies that possess unique characteristics, making some more appropriate for certain applications. All the wireless technologies that can be used in connected lighting systems and the IoT will not be discussed as there are many that are used or may be used in the future. Only the ones that seem most relevant to commercial connected lighting applications at this time will be discussed. Furthermore, many manufacturers incorporate Power over Ethernet (PoE), which allows for both data and power transfer through an Ethernet cable, into their connected lighting systems. In the future, new technologies that are developed may instead be used for connected lighting systems.

Common Wireless Technologies

Manufacturers are using different wireless technologies as the basis of their connected lighting systems as there are many wireless technologies that have been developed and may be

used for connectivity in the IoT. These technologies have many distinct characteristics including bandwidth, topology, and relation to a common model for network communication called the Open System Interconnection (OSI) model. The goal of using the OSI model as a reference for developers is to encourage interoperability (McMillan, 2011). The OSI model consists of seven layers that are shown in Figure 4.1a. This model encompasses the basic functions of a network and explains how data is transferred from one unit to another. The model separates the distinct functions of a network into layers, where each layer is independent from one another and represents a part of the communication process. For simplicity, the technologies will be

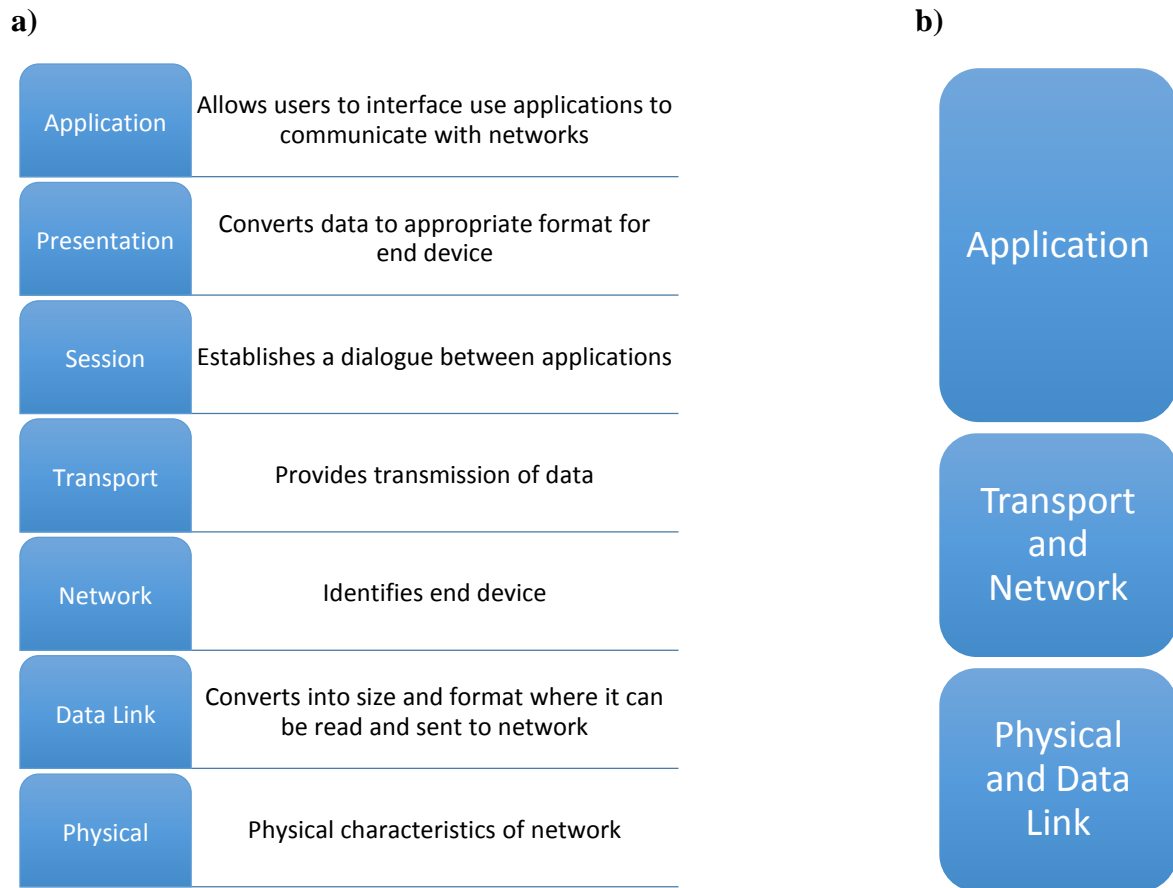

Figure 4.1: Open System Interconnection (OSI) Model: a) OSI Model and b) Simplified OSI Model

a) Created with information from *Cisco Networking Essentials* by McMillan, 2011 and b) from “Solid-State Lighting R&D Plan,” (p. 40), by DOE Solid-State Lighting Program, 2016.

discussed in reference to a simplified model shown in Figure 4.1b. This will be used to show the layers that the wireless protocol discussed operate in. Institute of Electrical and Electronics Engineers (IEEE) Standards, particularly IEEE 802 Standards for Local and Metropolitan Area Networks, are a basis for many of these technologies and will also be referenced as they are related to the OSI model and cover some of the layers discussed.

The bandwidth, or data transfer rate, is another important aspect that must be considered. Bandwidth does not describe how fast data travels, but rather how much data can be transferred through a connection in a certain amount of time. This rate is measured in bits per second. The amount of bandwidth required is highly dependent on the application. Most IoT sensors have low data rate requirements and therefore a low bandwidth solution can be used (Char, 2015). This can mean that transmission occurs at a lower frequency, which inherently has a lower data rate but better transmission distance. Traditionally, Wi-Fi is the most common method of data transmission and comes with the highest data rates. However, Wi-Fi struggles with a crowded frequency and is subject to interference. Due to the typically low data rate requirements and issues with interference many applications are pursuing transmission on a sub-GHz range (Char, 2015). Wireless technologies with varying bandwidths and frequencies will be discussed below.

The topology refers to the configuration of the network and shows how nodes, or parts of the network, are connected and arranged. In this chapter, each node refers to a single connected device in the connected lighting system, typically a sensor or controller located on the luminaire. There are several network topologies, but only two, the star and mesh topologies, are discussed in this section as they are the only ones typically used in connected lighting applications. The star topology represents a network arrangement where all nodes are connected to a central hub. A network with this topology will have a single point of failure (SPOF) since the hub is required

for any communication between nodes (McMillan, 2011). A network with a mesh topology has nodes that communicate with one another and relay data through other nodes. A mesh network does not have a single point of failure and when one node fails, data can still be transferred through other nodes. The star and mesh topologies are shown in Figure 4.2.

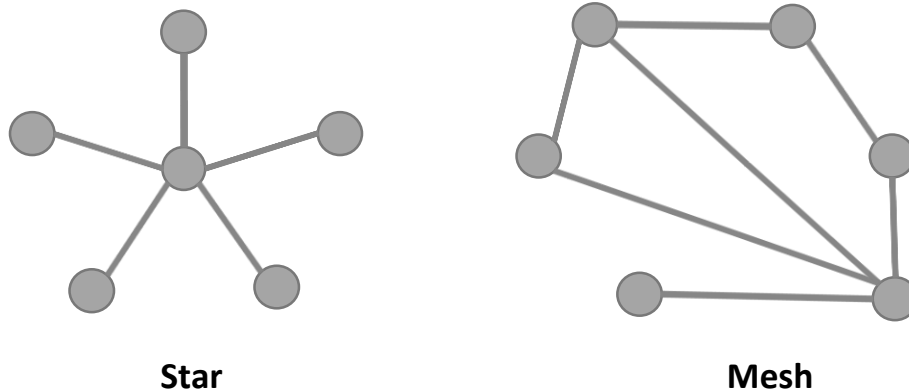

Figure 4.2: Network Topologies

As connected lighting is developing, there are a variety of wireless technologies that are being considered to connect luminaires and eventually the IoT. These technologies won't all be described in this paper. Instead, the focus will be on six wireless technologies that are being used by manufacturers in connected lighting systems: Wi-Fi, Bluetooth Smart, Thread, Zigbee, Z-Wave and EnOcean. These technologies operate in industrial, scientific, and medical (ISM) bands, which are reserved for radio frequency (RF) and don't require a license. The advantages and disadvantages of the different technologies will be discussed in the following sections. Criteria that will be discussed include topology, bandwidth, range, cost, power consumption, and potential for interference.

Wi-Fi

Wi-Fi is based on the IEEE Standard 802.11 for Wireless Local Area Networks (LANs), which only covers the physical and data link layer of the simplified OSI model and relies on other protocols to cover the other layers (Rzadkosz, 2015). There are several different versions

of this standard as it is constantly being developed and updated, but the one most commonly used is IEEE Standard 802.11n. Wi-Fi has raw data bandwidths that vary between 11 Mbps to hundreds of Mbps depending on the version of IEEE Standard 802.11 (Rzadkosz, 2015). Wi-Fi has a range of up to 100 meters, or approximately 328 feet (Labeodan, Bakker, Rosemann, & Zeiler, 2016). Wi-Fi operates in both the 2.4 GHz and 5 GHz bands and is centered around a router, which means it has a star topology. This means there is a single point of failure and that can be a huge disadvantage if the router goes down. The main advantage of Wi-Fi is that it is widely used so there is a well-established infrastructure for this technology. However, the high bandwidth increases the cost and consumes more power than the other wireless technologies that are being considered. The bandwidth and large power consumption make this wireless technology unsuitable for connected lighting applications as sensors only need to transfer small bits of data (Rzadkosz, 2015).

Bluetooth Smart

Bluetooth Smart, also referred to as Bluetooth Low Energy (BLE), is another wireless technology that is being considered for connected lighting systems. This technology was introduced in 2010 by the Bluetooth Special Interest Group (SIG) and operates in the 2.4 GHz band. BLE covers all of the OSI model layers and is currently installed on smartphones (Rzadkosz, 2015). BLE is ideal for short range applications and uses 40 channels, 3 of which are used for advertising (broadcasting, etc.) and 37 that are used for data (Guastella, 2016). This technology can hop between channels to avoid interference with other devices. Bluetooth Smart is designed for low-power operation and has a bandwidth of 1 Mbps (Labeodan, Bakker, Rosemann, & Zeiler, 2016). Currently, it has a star topology, but the Bluetooth Smart Mesh

Working Group formed in 2015 is working on incorporating mesh networking that may make this technology more applicable for the IoT.

Bluetooth Smart has a beacon capability that is used to determine the proximity of devices and communicate by intermittently broadcasting data. Devices that can receive beacons can enter a region and have the option to receive information from a beacon (Guastella, 2016). This would allow individuals to gather information about specific areas or even to have areas react to their presence. Beacon transmitters are well suited to being installed in lighting fixtures since lights are already strategically placed to cover an entire area the occupants move through (Guastella, 2016). As data is broadcast, smart devices can connect and use the data for various applications. The device can then be assigned a unique identifier so that the data can be personalized to that device. Another unique identifier is assigned to the beacon so that devices recognize the specific beacon that is broadcasting.

ZigBee

ZigBee was conceived in 1998 and is a wireless technology that is low cost and low power (Rzadkosz, 2015). The basis for this technology is IEEE Standard 802.15.4 for Low-Rate Wireless Networks. IEEE 802.15.4 covers the physical and data link layer of the simplified OSI model while ZigBee covers the upper two levels of the simplified model, the network and transport layer and the application layer (Rzadkosz, 2015). ZigBee operates in the 2.4GHz band, which is the same band as both Wi-Fi and Bluetooth Smart. ZigBee can support different topologies, but most commonly uses the mesh topology. The mesh network allows for the removal of a node without disruption of the whole system. This means that the mesh network has a self-healing ability to remain functional. ZigBee has a range of 10-20m, or approximately 30-70ft, but can cover a much larger area through nodal communication as it can support up to

65,000 nodes (Rzadkosz, 2015). The max data rate with ZigBee is 256 kbps (Labeodan, Bakker, Rosemann, & Zeiler, 2016).

Z-Wave

Z-Wave has been around since 2003 and is considered the “leading international wireless standard for control and automation in a residential environment” (Rzadkosz, 2015, p. 15). This technology covers all the OSI model layers, which makes it good for interoperability. It is low-power and operates in the sub-1 GHz band, which eliminates interference from the networks in the 2.4 GHz band. The max data rate offered is 200 kbps, which is comparable to the other technologies discussed. Z-Wave typically uses a mesh topology that allows the nodes to forward messages until it reaches its destination, but can also have a star topology (Labeodan, Bakker, Rosemann, & Zeiler, 2016). The maximum number of nodes that can be supported by a single network is 232 nodes, which could be easily exceeded if this technology were to be used for commercial connected lighting systems.

Thread

Thread is a much newer technology that was introduced in 2014 and is geared towards residential applications. On the simplified OSI model, it only covers the network and transport layer and IEEE 802.15.4 is used to cover the physical and data link layer (Rzadkosz, 2015). Unlike ZigBee, Thread doesn't specify an application layer. Thread operates in the 2.4 GHz band at 250 kbps and can be configured into different topologies (Thread Group, 2015). Like Zigbee and Z-Wave, Thread can support a star or mesh topology, however, Thread can only support approximately 200 nodes which is similar to the number for Z-Wave (Rzadkosz, 2015).

EnOcean

EnOcean focuses on self-powered technology. It is a wireless technology that focuses on energy harvesting from minute energy changes to create power for signal transmission (EnOcean, 2017). Energy can be harvested from motion, light, or thermal changes. This coupled with low energy use devices allows sensors to be self-powered creating even less reliance on wiring and allowing further flexibility. EnOcean has a data rate of 125 kbps and broadcasts at 902Mhz to offer high reliability and low interference. EnOcean additionally offers AES encryption protocols to protect networks from malicious hackers. EnOcean covers the physical, data link, and network layers in its architecture (EnOcean, 2017).

Power over Ethernet (PoE)

Several companies are using PoE technology in their connected lighting systems as a way to deliver both data and power to lighting devices via Ethernet cable. Traditionally, Ethernet was used for computer communication and is probably familiar as it is used in many homes for Internet connection. In 2003, IEEE 802.3af limited the power of Ethernet cables to 15.4 watts, but the power limits for Ethernet cables has increased with the subsequent IEEE standards and is currently at a transmission limit of 95 W per IEEE 802.3bt (UL, 2015). As new devices are developed with more functionality and higher power requirements, the standard was revised to accommodate these devices.

The major drive to using PoE for lighting is the growing use of LEDs that have much higher efficacies than traditional light sources and therefore require less power. With these low power requirements, lighting now falls under the power limits set forth in IEEE 802.3bt and can be powered and controlled by Ethernet cables (UL, 2015). The use of PoE in lighting can have several benefits.

The primary benefit of using PoE is that devices no longer need to be connected by two separate cables. Typical devices today will need one cable for the power supply and a second cable for data transmission. By supplying both power and data from the same cable, the time and cost of installing a new system is reduced. National Electric Code (NEC) Article 725 allows for communication cables to be routed without any protective conduit (UL, 2015). This further reduces the cost of wiring systems. Additionally, there is added flexibility since components can be easily disconnected and moved. PoE continues to develop and become more versatile. The increased power transmission limits have helped to encourage the use of smart devices since it inherently reduces the cost of installing and powering these devices.

Summary

There are several wireless and wired technologies used by manufacturers in both residential and commercial connected lighting systems. The residential smart lighting market uses a variety of the wireless technologies discussed, however, the large scale of commercial lighting systems may prohibit the use of these technologies as some do not have sufficient capability for large-scale deployment. A summary of the most common wireless technologies and the associated key parameters that differentiates each is listed in Table 4.1 on the next page. Each technology has its own merits and is selected based on the requirements of the connected lighting system being installed.

The use of PoE is also becoming more popular for commercial lighting solutions as this will minimize interference and reduce the cost of installing the system. However, if the existing system is already wired to receive communication and power from separate cables this may not be the best option. Additionally, if there is an existing Wi-Fi system and interference is not a major consideration it may be preferable to use the installed Wi-Fi network.

Table 4.1: Summary of Wireless Technology Characteristics

Adapted from “On the Application of Wireless Sensors and Actuators Networks in Existing Buildings for Occupancy Detection and Occupancy-driven Lighting Control,” by Labeodan, Bakker, Rosemann, & Zeiler, 2016. Adapted with information from (Rzadkosz, 2015) and (Thread Group, 2015)

Characteristics	Wi-Fi	BLE	ZigBee	Z-Wave	Thread	EnOcean
Frequency	2.4 GHz, 5 GHz	2.4 GHz	2.4 GHz	<1 GHz	2.4 GHz	902 MHz
Data Rate	54 Mbps	1 Mbps	256 kbps	200 kbps	250 kbps	125 kbps
Relative Power Consumption	Very High	Low	Low	Low	Low	Very Low
Topology	Star	Star	Star, Mesh	Star, Mesh	Star, Mesh	Mesh
Approximate Range (ft)	325	160	30 - 325	100 - 980	325	100 - 980

Chapter 5 - Connected Lighting Effects on Lighting Controls

The effects of connected lighting on lighting controls will be significant. This chapter will discuss this impact, particularly the effect on the adoption of lighting control systems, products and system architectures. The implementation of lighting control systems in commercial buildings has been slow, however, connected lighting control systems may provide an opportunity for more widespread adoption with features and benefits that traditional systems don't offer. One of the largest effects on lighting controls is that connected lighting control devices can be wireless, which means that lighting control systems may no longer require wiring to connect all the individual components. This has a significant effect on how lighting control systems will be designed and installed.

Another large aspect of lighting control systems that will be affected by the advent of connected lighting is the configuration since manufacturers are using different system structures to accommodate wireless devices and fixture-integrated sensors. Current lighting control systems are centralized since all components are connected to a room controller or lighting control panel. With the new systems, sensors can still be centrally located and report back to a central controller, but can also be integrated into or directly connected to the luminaire itself to provide individual control of fixtures.

Adoption of Lighting Control Systems

As was discussed earlier and shown in Table 3.1, 68% of all commercial buildings in 2015 had no automatic lighting controls (Navigant Consulting, 2016). Traditional automatic lighting controls have not been widely implemented for a number of reasons. The complexity and cost associated with the installation and design of a comprehensive lighting control system is

high. Also, it is hard to figure out exactly how much is being saved since lighting control energy savings can't be effectively measured (DOE SSL Program, 2016).

Connected lighting provides the opportunity for more widespread adoption of automatic lighting control systems. Costs for these systems may be offset by the additional features and data collection which can be used for further energy savings. They will have greater performance and increase energy savings, which will increase the value of having a lighting control system (DOE SSL Program, 2016). Furthermore, wireless devices will reduce some of the upfront costs associated with wiring and installation. With increased performance and energy savings of connected lighting systems, the adoption of lighting controls systems will increase.

Products

Light fixtures and lighting control products will also undergo changes as connected lighting becomes more prevalent. Although products will retain their original function and use the same technology to complete these functions, connected lighting products will be different than those traditionally used. In particular, two products that are not typically part of conventional lighting control systems are being integrated into many of the connected lighting systems on the market. Sensors integrated directly into each luminaire provide unparalleled control and ease of installation. Wireless devices and self-powered devices are also being introduced. The integration of these products into connected lighting systems are greatly affecting lighting controls.

Currently, there are several connected lighting systems with sensors integral to the luminaire on the market. These luminaires typically have both daylight sensors and occupancy sensors and some even have embedded controllers. The use of sensors on or near each luminaire

provides a much higher density of sensor data that can be used to determine control signals. This high density will provide data that can be used for very precise lighting control since light levels in certain locations can be determined. This individualized control will increase energy savings. The presence of so many sensors can also provide data on several characteristics including occupancy, light levels, temperature and CO₂ levels throughout the space.

Wireless lighting products such as sensors and switches are now on the market and are becoming more popular as wireless communication technology and batteries have improved (Labeodan, Bakker, Rosemann, & Zeiler, 2016). One main reason that wireless devices are becoming popular is primarily due to cost. Cost savings associated with installation and material can be significant since the required labor and amount of copper wire is reduced (Penny, 2014). The absence of wiring also makes it easier to install devices in existing structures where adding wiring may pose problems and introduces flexibility that was not available with previous devices. Since lighting control systems are typically installed before furniture is located and the occupants move in, the ability to move the sensor after the building is occupied can improve occupant comfort and increase energy efficiency (Labeodan, Bakker, Rosemann, & Zeiler, 2016). Wireless devices will provide an easy way to manage lighting controls since they can connect wirelessly with building management systems and are particularly popular for retrofit projects where the installation of additional wiring can be very expensive. Wireless devices are also having an impact on how the sensors receive power as some of the wireless sensors on the market are self-powered with either batteries or solar cells. These self-powered devices provide energy savings since they require no power to be operated. Some battery-powered sensors have a life of up to six years (Labeodan, Bakker, Rosemann, & Zeiler, 2016).

Products for connected lighting systems will be continually developed as the systems become more popular. The introduction of new products for connected systems is already being seen as luminaire-integrated sensors and controls are joining the variety of connected lighting products. Furthermore, wireless devices powered by batteries or solar cells are also being used to provide further energy savings and ease the complexity of the installation of lighting controls. Although these products are on the market now, more products will certainly be added as connected lighting systems are developed further.

System Configuration

The configuration of automatic lighting control systems will also change as connected lighting becomes popular. Most commercial lighting control systems installed in buildings require wiring to connect all the components, but connected lighting systems are incorporating wireless connectivity for communication between devices. Providing a wireless network will require different components than those used in a conventional system. Manufacturers are also selling luminaires with integrated sensors and controls that eliminate the need for wall-mounted or ceiling-mounted sensors. Several companies are using Power over Ethernet (PoE) to power luminaires rather than traditional alternating current (AC) power. As connected lighting develops, system configurations for connected lighting control systems will surely change. For now, manufacturers are using proprietary devices and different arrangements to provide connected lighting solutions that vary slightly from conventional systems.

Conventional Lighting Control Systems

A typical lighting control system consists of the following components: lighting control panels, room controllers, sensors, switches and a combination of line and low voltage wiring. A typical arrangement of a lighting control system for a single space is shown in Figure 5.1. In this lighting control system, all the components are centered around the room controller, which acts as the brain of the system and is located in the ceiling plenum.

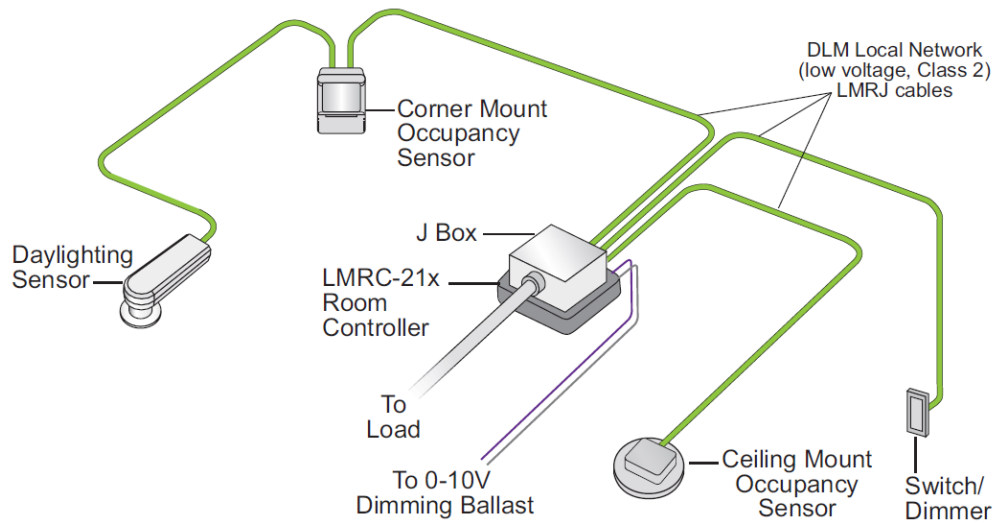

Figure 5.1: Typical Arrangement of Lighting Control System

From “LMRC-211 DLM Single Relay w/0-10V Dimming Room Controller Quick Start Guide,” by Legrand, 2016. Reprinted with permission. Permission included in Appendix A.

In this digital lighting control system, the sensors, switches and room controller communicate with one another via the wires that are directly connecting them. When a digital lighting control system is installed, all of the sensors are calibrated and settings are adjusted, sometimes automatically. Automatic configuration of sensor parameters allows for quick and easy installation; however, the parameters can be adjusted manually at setup or at a later date, typically with the help of a professional. There are several ways to manually modify the system parameters based on how the proprietary system works. Some digital sensors have LCD displays

and pushbuttons located on the device that can be used to adjust settings, while others can be adjusted remotely with wireless tools. Furthermore, many digital systems have proprietary software accessed through computers to monitor, manage and set up additional features.

To show the connections between devices, wiring diagrams are provided by manufacturers. A typical wiring diagram for a lighting control system is shown in Figure 5.2. Line voltage wires carry the standard voltage present in the building, typically 120V or 277V. Low voltage wires carry a voltage that is less than 30V, typically 10-24VDC, that is transformed from the standard voltage. These low voltage wires do not need to be run in conduit per most codes and is safer to install. The sensors are used to collect data that is then relayed to the room controller via low voltage cables. The room controller then processes this data and sends control signals to the load, or luminaires via line voltage cables. Additional sensors and switches can be added by directly connecting them to one another as shown.

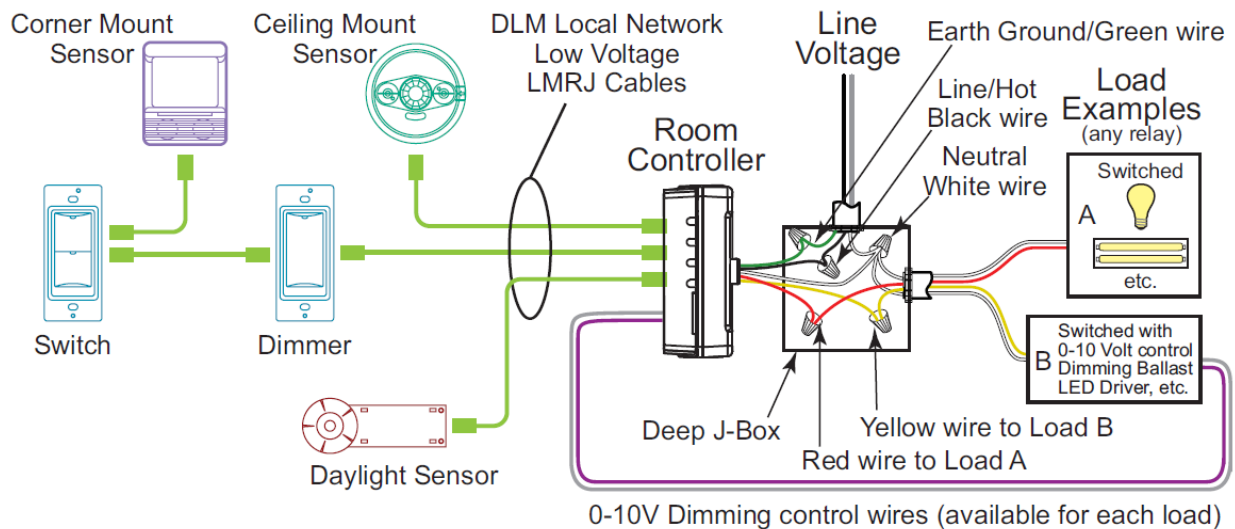

Figure 5.2: Wiring Diagram for a Typical Lighting Control System

From “LMRC-211 DLM Single Relay w/0-10V Dimming Room Controller Quick Start Guide,” by Legrand, 2016. Reprinted with permission. Permission included in Appendix A.

Connected Lighting Control Systems

Connected lighting control systems will be arranged differently than conventional systems. Although connected lighting systems may have sensors located in the wall or ceiling similar to those used in conventional automatic lighting control systems, many systems offer sensors that are directly integrated into or located on the luminaires. Connected lighting systems may also have wireless devices that require wireless connectivity and additional equipment that traditional systems don't have.

Control Approaches for Luminaires with Integrated Sensors

There are two basic approaches used to control luminaires in a system with luminaire-based sensors: a central approach and a distributed approach (Pandharipande & Caicedo, 2015). These approaches apply to both wired and wireless systems. Figure 5.3 shows the central control approach, which has a primary lighting controller that receives data from each sensor and sends control signals back to the luminaires for lumen output adjustment.

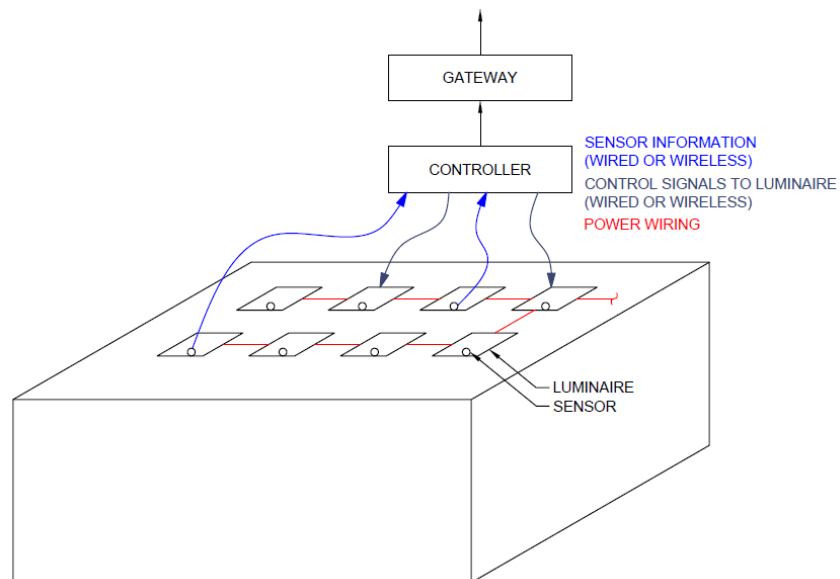

Figure 5.3: Central Control Approach

Adapted from “Smart Indoor Lighting Systems with Luminaire-based Sensing: A Review of Lighting Control Approaches,” by Pandharipande & Caicedo, 2015.

This control approach eliminates the need for a controller on each device, which may reduce the cost and complexity of installing the system. However, the primary controller may cause issues for lighting systems with hundreds of lights since all of the processing is done at one device. The lighting controller in this approach has a threshold for the number of inputs and outputs, which will limit the number of lights that can be controlled. Thus, several devices may need to be used for large applications. With all of the luminaires being controlled by a single device, the failure of this device may inhibit the function of the lighting control system.

The distributed lighting system, shown in Figure 5.4, has local controllers at every luminaire that process data from the sensors and control the luminaires. Local controllers will have a lower number of outputs and inputs than the centralized controller described in the previous architecture which lowers the processing power requirement of each controller. Also, the “distributed control systems allow for better modularity and scalability” (Pandharipande & Caicedo, 2015). This approach allows for a large number of luminaires to be controlled

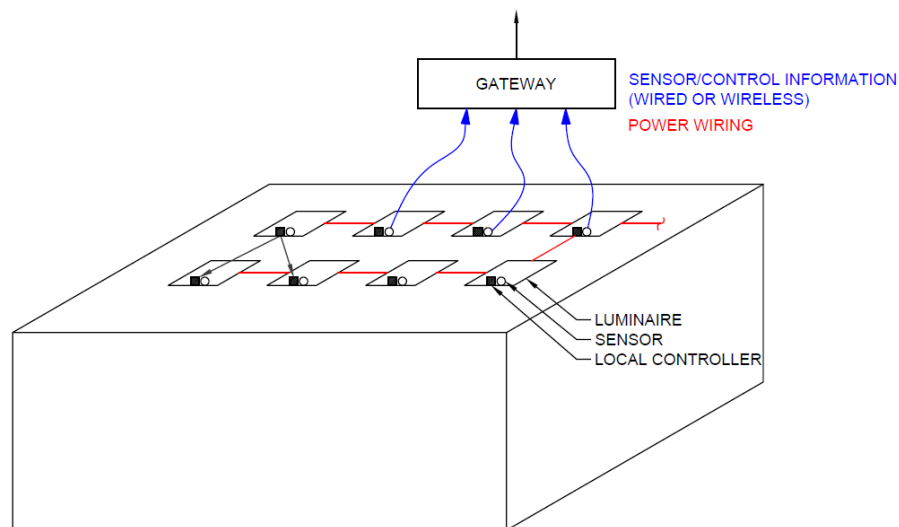

Figure 5.4: Distributed Control Approach

Adapted from “Smart Indoor Lighting Systems with Luminaire-based Sensing: A Review of Lighting Control Approaches,” by Pandharipande & Caicedo, 2015.

simultaneously and individually. The local controllers can operate independently from one another or exchange data with surrounding controllers to provide appropriate lighting control.

Another approach is to use a combination of both the central and distributed approach. For example, local controllers at each luminaire may be used transmit data to a central controller that communicates with a building management system (Pandharipande & Caicedo, 2015). This building management system may also use data from the local controllers for other building systems such as HVAC or security systems. Manufacturers typically specify which approach is used in their luminaire-based sensors on the fixture data sheets.

Examples of Connected Lighting Systems

Connected lighting control systems have layouts that vary slightly from traditional systems since wireless devices, fixture-integrated sensors and PoE are being incorporated. As previously mentioned, manufacturers are using different layouts and pieces of equipment for their proprietary connected lighting systems. An overview of a connected lighting system that uses PoE technology and luminaires with integrated sensors will first be described. Then, a system that uses PoE technology, wireless communication, and stand-alone sensors will be described. The systems described are not inclusive of all connected lighting solutions since no standard architecture is used, but rather a representation of two systems on the market.

Several companies are using PoE technology as the basis for their connected lighting systems. Figure 5.5 shows a simplified diagram of one commercially available system, the Cree SmartCast® PoE intelligent lighting system. This system has luminaires with integrated occupancy and ambient light sensors as well as microprocessor control. This means that no central controller is required and represents the distributed control approach mentioned earlier. A standard Ethernet cable is used to power the luminaires and switches and connect them to the

lighting control network. The use of Ethernet cable for both power and data eliminates the use of AC wiring (Cree, Inc., 2016). The PoE switch is used to provide low-voltage power and communication between the lighting system and the PC, internet or cloud. This switch would most likely be the only device that is connected to the main electrical system with AC wiring. A PC application sets up and manages the system.

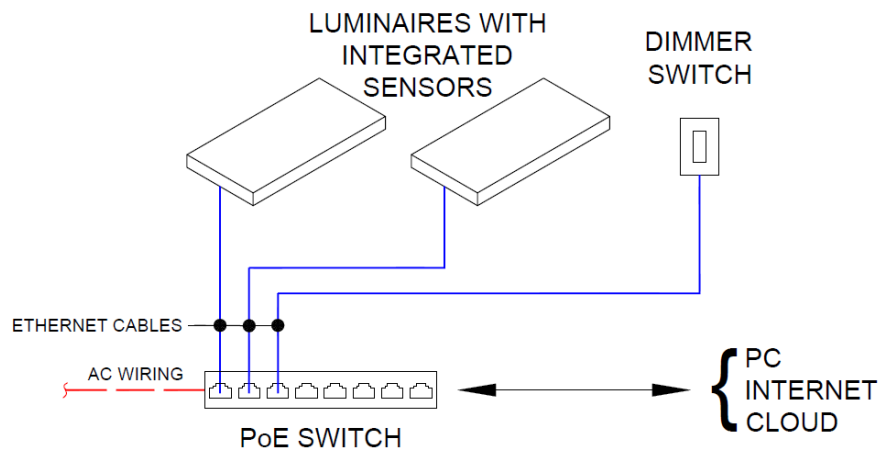

Figure 5.5: Connected Lighting System Configuration with PoE Technology and Luminaire-Integrated Sensors

Adapted from “Cree SmartCast® PoE Technology,” by Cree, Inc., 2016.

As shown, this system is very different from the conventional lighting system shown in Figure 5.1 and Figure 5.2. In the connected lighting system, the use of low voltage and line voltage wires is not necessary and greatly simplifies the wiring for the entire system. Furthermore, the sensors and controllers are directly integrated into the luminaires, so no wiring in the field is necessary to connect the luminaires to their sensors and controls. However, there are only certain luminaires that have the fixture-integrated controls and sensors along with the PoE capability, which will limit the choices that are available to the design team.

The next commercial connected lighting system that will be discussed is shown in Figure 5.6. This system also uses PoE technology, but it is used to provide power and data for gateways

rather than the luminaires, sensors, and control units. This system does not have fixture-integrated controls and sensors; instead, the control unit and sensors are connected to the luminaire in a way that is similar to the conventional lighting control system in Figure 5.2. Line and neutral wires are used along with 0-10V dimming wires to connect the control unit and LED driver.

In this connected lighting system, PoE switches are used to provide power and data for gateways that are used to communicate with the sensors and controllers wirelessly. The PoE switch is connected to the building’s network through the energy manager. The energy manager and PoE switch may be located in the same enclosure in an electrical room or closet. This system incorporates control units and sensors into third-party luminaires, which allows owners to use the fixtures they want rather than being limited to specific ones.

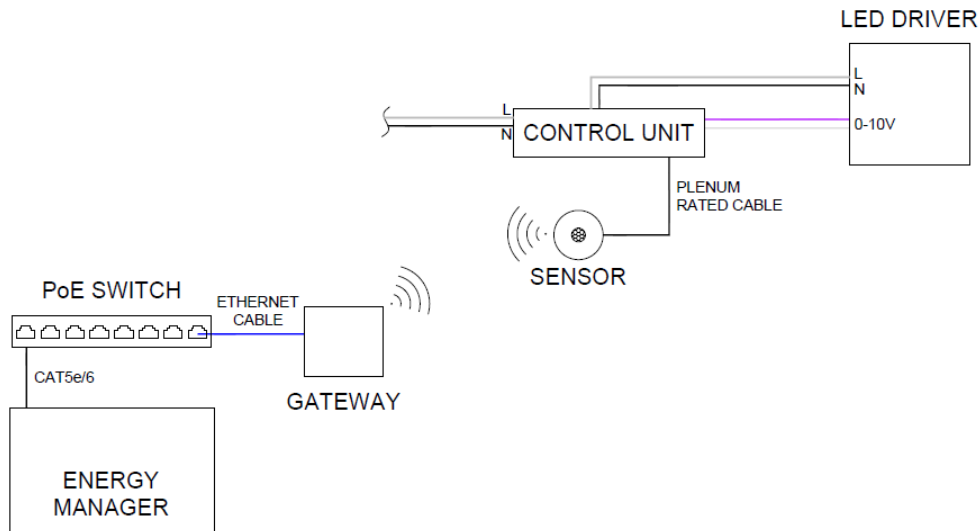

Figure 5.6: Connected Lighting System Configuration with PoE Technology and Stand-alone Sensors and Controls

Adapted from “Enlighted Wiring Diagrams,” by Enlighted, 2014.

Chapter 6 - Connected Lighting Effects on Lighting Design

Connected lighting will also have a large effect on commercial lighting design. The unfamiliarity of the design of connected lighting systems will be a huge hurdle, as the design will be affected by several factors. The increased performance of connected lighting systems will provide increased flexibility and control, but will require extensive software integration. Although this increased performance will provide many benefits, until a connected lighting system is standardized, the design of such a system may be very complex. Furthermore, since the controls will rely mostly on software rather than hardware, the IT industry will need to be more involved in these systems. Once some of these design aspects are standardized, there will be several benefits. Compliance with energy codes and standards will be accomplished more easily since new control schemes can be accomplished with software updates (Seed Labs, 2015). Connected lighting can also be integrated into other applications and systems. For example, sensors for connected lighting systems can be used for other building systems such as heating, ventilating and air conditioning (HVAC) systems.

Features

As connected lighting systems are developed, new features are being added to enhance the lighting system. Color-tunable fixtures are being incorporated into connected lighting systems to provide both aesthetic and medical benefits. Connected luminaires are also being used for indoor positioning systems, particularly for retail applications. The addition of new features will continue as lighting systems are developed.

Color-Tunability

Color-tunable products are also being incorporated into connected lighting systems as an additional feature. These products allow the user to change the color or Correlated Color Temperature (CCT) of the light emitted from the luminaire. The CCT measures the color appearance of the light emitted by a lamp and ratings are in degrees Kelvin (K). As the rating gets lower, the light source appears warmer. There are three types of color-tunable luminaires: dim-to-warm, white-tunable, and full-color tunable (U.S. Department of Energy, n.d.). Dim-to-warm products have decreasing CCT ratings as the source is dimmed and light output decreases. This type of product may be useful in applications such as restaurants, lobbies, theaters, and homes since warm settings are typically preferred in these spaces. White-tunable products are used when changes in the CCT ratings of the lamp are desired without changing the light output. Full-color tunable products, also referred to as spectrally tunable or color changing, can create light in different colors. The connected lighting products that are color-tunable are typically white-tunable.

Color-tunable products can be useful for many reasons. Warm or cool settings can be created to suit occupant preference and increase productivity. Also, lighting may be used to support or correct the circadian system. The circadian rhythm is how a person reacts to daily changes from day light to darkness and how it effects a person's physical, mental and behavioral states. Current use of lighting that does not align with what is naturally produced by the day and night cycle can have negative impacts on a person's health. A disrupted circadian system has been linked to symptoms such as fatigue, cancer, obesity, diabetes, and depression among other symptoms (USAI Lighting, 2015).

By adjusting the color and brightness of light to better mimic natural lighting, a person's biological clock can be regulated and the mood, alertness, and health of the occupants can be improved. In modern day medicine, lighting has been used to help with jet lag, depression, treat symptoms of Alzheimer's disease and improve overall quality of life. The use of light to treat medical issues is a recent discovery and it is anticipated to have many more potential benefits as prescription lighting is researched further.

Indoor Positioning

Connected lighting is also used in indoor positioning systems (IPS) that are similar to global positioning systems (GPS), but are used to track the location of people or products indoors. This type of system has been developed by several manufacturers for the retail market where location-based services can provide customers with an interactive shopping experience and increase operational efficiency. This feature is now being incorporated directly into the luminaires of connected lighting systems, which are used to determine the location of shoppers based on their smartphones. Manufacturers are using Visible Light Communication (VLC) technology to send codes to smartphones and Bluetooth Smart beacons (Philips, 2016).

IPS can be used to provide several different location-based services in stores to benefit both the customer and the store itself. It can be used to help shoppers save time by providing the location of products and directing them throughout the store and also help them save money since coupons or promotions for products can be proposed to customers as they approach a product's location (Philips, 2016). IPS systems installed in stores can also provide benefits for the owners. An interactive shopping experience can increase revenue by enticing customers and promoting products as customers walk through the store. Customer traffic in aisles can be monitored to improve store layout.

Energy Code Compliance

The main drive for lighting control systems comes from energy codes. Compliance with commercial building energy standards such as ANSI/ASHRAE/IES Standard 90.1 is required in many jurisdictions. ANSI/ASHRAE/IES Standard 90.1-2016 is a popular standard in the United States that is released every three years. Each subsequent release of the standard is more stringent than the previous to drive higher energy efficiency. Table 6.1 shows the energy savings that each updated version of the code provides as compared to the previous version. As shown, the percentage of savings is estimated to be almost constant over the next 20 years.

Table 6.1: Future ANSI/ASHRAE/IES Standard 90.1 Energy Savings Compared to Previous Versions

Adapted from “Impacts of Model Building Energy Codes,” by Athalye, Sivaraman, Elliott, Liu, & Bartlett, 2016.

Commercial	
Code Edition	% Savings Compared to Previous Code
90.1-2016	5
90.1-2019	5
90.1-2022	4
90.1-2025	4
90.1-2028	5
90.1-2031	5
90.1-2034	5
90.1-2037	5

ANSI/ASHRAE/IES Standard 90.1-2016 provides minimum requirements for lighting controls based on common space types. In this version of the standard there are nine different control functions that include stipulations for where manual controls must be used, restrictions for automatically controlled lighting, and requirements of bilevel lighting and automatic daylight

responsive controls. Many space types are required to meet several of these control functions. With conventional lighting systems, additional sensors and wiring are required to meet energy codes, especially as they become more stringent. With connected lighting, energy codes can be met with software upgrades rather than wiring. This means that as energy codes are updated, lighting control systems can be modified to meet the new code without extensive modification of the physical parts of the system.

Wiring

Connected lighting is also increasing the popularity of wireless solutions that will change the way lighting control systems are designed. Conventional lighting control systems have complex wiring that increases installation costs and limits where devices can be placed. The flexibility of being able to move wireless sensors and switches after they are located will overcome some of the uncertainty of device placement during the design phase. The coordination of the wireless lighting sensors and switches with other wired devices for both lighting systems and other building systems will be greatly reduced.

As wireless lighting controls become more popular, more attention will need to be paid to wireless network infrastructure and software issues that may occur (Penny, 2014). Without wiring, lighting control systems will become less reliable as they will depend on wireless network connections subject to interference. The shift to lighting control systems that are mostly software-based will also create a shift in the labor. New systems may not have to be installed by an electrician and can instead be installed by facility or IT staff.

Integration into Building Systems and Potential Applications

The connected lighting market is still young and has a long way to go before it is implemented in more buildings and connected to lots of devices. Integration of a connected lighting system into other building systems will bring lots of opportunities to provide an enhanced indoor environment for building occupants and will also be used to increase efficiency, both in space use and energy. The possibilities for connected lighting in future applications seem endless, especially since the level of individual control afforded to people will be increased.

Connected lighting systems can be integrated into other building systems such as the HVAC, power, and fire alarm systems. Connected lighting sensors can be used to control HVAC equipment and plug loads if an open standard that is compatible with different devices produced by manufacturers is used. For example, occupancy sensors for lighting can be used to adjust the thermostat when there is no one in the space (Penny, 2014). Connected lighting may also be used in conjunction with the fire alarm system to help guide occupants to an exit in an emergency (Seed Labs, 2015).

Connected lighting may also be used to improve building performance and reduce operational costs. The use of demand response techniques in a completely integrated building management system encompassing both mechanical and electrical systems can provide huge savings in terms of energy costs. Plug loads may be controlled wirelessly with the sensors and controllers of the connected lighting system. Optimization of the equipment schedule can significantly reduce peak loads, thereby saving money on electricity bills (Andhare, 2015).

One of the most obvious features of a connected lighting system that will affect lighting design is the individual control available to the occupants. With connected lighting, there can be many control points, or switches, that communicate wirelessly. This will give occupants direct

control over their immediate surrounding since lighting may be controlled via a smartphone app as long as they are within range. There are several applications where this might be used. Open offices may use this individual control to increase employee satisfaction. Also, restaurants may use this to give their customers the ability to change the lighting at their own table (Seed Labs, 2015).

Lighting controls are also not restricted to communicating with luminaires that they are directly connected to since wireless communication can be used instead. This will allow the connected lighting system to control any luminaire in the entire building from one spot. Wireless controls can be used to turn on individual luminaires in a pattern and set up or easily change scenes. This will also allow for control of lighting on different circuits, which was possible with a traditional system, but at a price. These circuits can be grouped together so they can all be controlled in the same way.

Chapter 7 - Case Studies

There have been several connected lighting solutions implemented in buildings around the world. The Edge is one building that has installed a connected lighting system to provide an integrated building where tenants could have a personalized experience with control over their surroundings. The other case study that will be discussed is a Carrefour market that uses connected lighting to enhance a customer's shopping experience with indoor positioning.

The Edge

A connected lighting system was installed in The Edge, a 15-story, 430,500 square foot office building located in Amsterdam and opened in 2015 (Philips Lighting, 2016). The building received the highest Building Research Establishment Environmental Assessment Methodology (BREEAM) score that has ever been awarded, partly due to the connected lighting system. The building houses almost 6,500 luminaires, 3,000 of which have integrated sensors. For this project, Power over Ethernet (PoE) technology was used for the lighting system and 750 PoE switches were installed to connect the network and luminaires (Philips Lighting, 2016).

One of the main objectives of the connected lighting system in The Edge was to provide an environment that the occupants could control. The connected lighting system is integrated with the HVAC system so employees can control both the temperature and lighting at their desk with an app on their smartphone. To provide this individual control, Visible Light Communication (VLC) was used. VLC uses light to determine the occupant's location by sending a code that is intercepted by the camera on the occupant's smartphone (Philips Lighting, 2016).

The luminaire-integrated sensors are used to capture and send occupancy and light level data so that the building systems can be adjusted to reflect real-time conditions. In addition to

using sensor data to track conditions, this system can be used to make suggestions to its occupants and promote effective use of the space. A unique feature of this building is that no one is assigned specific work stations (Randall, 2015). Upon entry into the building, the system detects the occupant and based on historic data of the user's preferences will suggest where they should sit. The smart system will consider temperature preferences and schedules to make these suggestions. By using the worker's schedules, the Edge building can host 2,500 workers while only having 1,000 desks (Randall, 2015). This level of efficiency can often allow large portions of the building to be shut-down at a time to reduce energy usage. These features are accessible through an employee's personal smart phone, which can be used to synchronize their schedule or even track colleagues.

Along with individual control and effective space use, this connected lighting system was used to increase energy efficiency by providing operation and energy consumption data to building managers. Software is used to control and manage the entire system and allows the user to have complete control of either a single luminaire or all the luminaires in the building. This software is also used to collect data from the luminaires and provide reports that staff can use to track energy consumption. The expected annual energy cost savings for the connected lighting installation is \$100,000 (Philips Lighting, 2016). The cost of the installation and design of this system has not been disclosed, however information about the return on investment has been released. It is expected that the project will have a return on investment in about eight years (Randall, 2015). This case study shows a variety of applications that connected lighting systems are being used for currently.

Carrefour Market

Carrefour, a large French retailer with 10,800 stores, installed a connected lighting system in one of their markets in Lille, France. This connected lighting system consists of 800 linear LED fixtures, but has an additional feature as it also provides indoor positioning to enhance shoppers' experiences (Philips, 2014). Indoor positioning is similar to global positioning systems (GPS), but determines the location of the occupants within a store rather than somebody's position on the globe.

The connected lighting system in the renovated Carrefour market uses visible light communication (VLC) technology to transmit a code to smartphones and pinpoint their position. This technology can identify the location with an accuracy of under half of a meter, approximately 1.5ft (Philips, 2014). Customers can use a smartphone app to find promotions for products and report those that are out of stock. The indoor positioning system will show promotions on products as the shopper walks near them. Along with the enhanced shopping experience, the connected lighting system provided substantial energy savings over the one previously installed. It is estimated that the energy consumption of the lighting system was reduced by 50% (Philips, 2014). The installation of a connected lighting system in this instance provided even more than just energy savings as it provided an interactive experience for consumers.

Chapter 8 - Conclusion

The emergence of the Internet of Things (IoT) has brought about a revolution in lighting referred to as connected lighting or smart lighting. Connected lighting allows for communication between a lighting system, its surroundings, other devices, and people. The United States Department of Energy (DOE) hopes that connected lighting solutions will increase the use of automatic lighting control systems.

The four main automatic lighting controls strategies are dimming, occupancy control, daylight harvesting and time control. These strategies will certainly be used in connected lighting systems that are rapidly developing. Manufacturers are focused on developing connected lighting since solid state lighting (SSL), which uses light emitting diodes (LEDs), have become the industry standard and inherently lend themselves to digital controls.

There are a number of technologies that are being used in connected lighting systems on the market including wireless technologies such as ZigBee or Bluetooth Smart and wired technology like Power over Ethernet. These technologies have different characteristics such as bandwidth, topology, and range that lend themselves more appropriately to certain applications.

Many connected lighting products will be very similar to conventional lighting products, however, there are wireless sensors and switches that are self-powered by batteries or solar cells. The use of wireless devices can reduce the first cost and eliminate space constraints that may be associated with wire installation. With the advent of wireless devices, connected lighting systems will need to provide wireless network infrastructure that will change the way these systems are designed and installed as compared to conventional systems. Besides that, the use of PoE technology will require PoE switches not seen in conventional systems. The products and

configuration of connected lighting systems will certainly be different than lighting systems currently installed in commercial buildings.

Currently, lighting controls in most buildings are wired and have limited functional flexibility. Connected lighting introduces flexibility that is otherwise unavailable and will be an important aspect of lighting control systems of the future since one of the main drivers of lighting controls is energy efficiency. Energy codes such as ANSI/ASHRAE/IES Standard 90.1 are adopted by jurisdictions and require specific lighting control strategies in certain space types. As codes are updated, lighting control requirements become more stringent and thus, control systems become more complicated. Connected lighting control systems can be updated to comply with requirements of updated codes with a software update (Seed Labs, 2015). The integration of connected lighting and other building systems will provide great performance in terms of both energy consumption and function. Also, connected lighting can be used for other applications such as indoor positioning.

Connected lighting solutions are currently being implemented to take advantage of inter-luminaire communication, however, the solutions of future connected lighting systems will most likely be much more complex and have many additional features that are not fully realized yet. Advances in technology will provide even more opportunities for connected lighting applications to be used for benefits and features that seem impossible with current technology. As connected lighting systems are developed further, more features will be available and additional research into the systems will need to occur for proper installation and integration into buildings.

References

- Andhare, S. (2015, March 2). *IoT In Commercial Buildings - Connected Lighting & Beyond*. Retrieved from Daintree Web Site: <http://www.daintree.net/blog/iot-in-commercial-buildings-connected-lighting-beyond/>
- Anritsu Company. (2011, July). *Fundamentals of interference in wireless networks*.
- Athalye, R., Sivaraman, D., Elliott, D., Liu, B., & Bartlett, R. (2016). *Impacts of model energy codes*. Richland, WA: Pacific Northwest National Laboratory.
- Black & Veatch Insights Group. (2016). *2016 strategic directions: smart city/smart utility report*. Overland Park: Black & Veatch Corporation.
- Char, K. (2015, April 14). *Internet of Things system design with integrated wireless MCUs*. Retrieved from Silicon Labs Web site: <http://www.silabs.com/documents/public/white-papers/Internet-of-Things-System-Design-with-Integrated-Wireless-MCUs.pdf>
- Cree, Inc. (2016, July 19). *Cree SmartCast PoE Technology*. Retrieved from Cree Web Site: <https://www.creelink.com/exLink.asp?8164908OP24J86I32883148&view=1>
- DOE Solid-State Lighting Program. (2016, June). *Solid-state lighting R&D plan*. (J. Brodrick, Ed.) Retrieved from https://energy.gov/sites/prod/files/2016/06/f32/ssl_rd-plan_%20jun2016_2.pdf
- DOE SSL Program. (2016, October 16). *Connected lighting systems meeting report*. Retrieved from U.S. Department of Energy Web site: https://energy.gov/sites/prod/files/2016/10/f33/cls-report_oct2016.pdf
- Enlighted. (2014, February 24). *Enlighted Wiring Diagrams*. Retrieved from Enlighted Web site: <http://info.enlightedinc.com/rs/000-IKN-871/images/Enlighted%20Wiring%20Diagrams.pdf>
- EnOcean. (2017). *Technology*. Retrieved from EnOcean Web Site: <https://www.enocean.com/en/technology/>
- Ericsson. (2016, November). *Ericsson mobility report*. Retrieved from Ericsson Web site: <https://www.ericsson.com/assets/local/mobility-report/documents/2016/ericsson-mobility-report-november-2016.pdf>
- Guastella, S. (2016). Advanced Bluetooth 4.0+ based smart lighting technology. *LED Professional Review* (54), 52-55.
- Labeodan, T., Bakker, C. D., Rosemann, A., & Zeiler, W. (2016). On the application of wireless sensors and actuators network in existing buildings for occupancy detection and occupancy-driven lighting control. *Energy and Buildings*, 127, 75-83. doi:<http://doi.org/10.1016/j.enbuild.2016.05.077>

- Legrand. (2016, November). *LMRC-211 DLM single relay w/0-10V dimming room controller quick start guide*. Retrieved from Legrand Web site: http://www.legrand.us/-/media/brands/wattstopper/resources/installation-instructions/ws-install-lmrc211_12205r2.ashx
- Mathews, E., & Muller, G. (2016). Transition from closed system to internet of things: a study in standardizing building lighting systems. *2016 11th System of Systems Engineering Conference*, (pp. 1-6). Kongsberg. doi:10.1109/SYSOSE.2016.7542912
- McMillan, T. (2011). *Cisco networking essentials*. John Wiley & Sons, Incorporated.
- Moniz, E. (2013, September 19). A clean energy revolution -- now. Washington D.C., United States of America.
- National Instruments. (2012, September 28). Wireless data acquisition: range vs. throughput.
- Navigant Consulting. (2016, September). *Energy savings forecast of solid-state lighting in general illumination applications*. Retrieved from U.S. Department of Energy Web site: https://energy.gov/sites/prod/files/2016/09/f33/energysavingsforecast16_2.pdf
- Pandharipande, A., & Caicedo, D. (2015, October 1). Smart indoor lighting systems with luminaire-based sensing: a review of lighting control approaches. *Energy and Buildings*, *104*, 369-377. doi:<http://doi.org/10.1016/j.enbuild.2015.07.035>
- Penny, J. (2014, August). Customize lighting control with wireless flexibility: mesh networks for devices create greater granularity with minimal disruption. *Buildings*, *108*(8), 28-32.
- Philips. (2014). *Indoor positioning Carrefour case study*. Retrieved from Philips Lighting Web site: http://images.philips.com/is/content/PhilipsConsumer/PDFDownloads/Global/CALI20160121_001-UPD-en_AA-carrefour-case-study.pdf
- Philips. (2016). *Indoor positioning white paper*. Retrieved from Philips Lighting Web site: <http://www.lighting.philips.com/main/systems/themes/led-based-indoor-positioning/white-paper>
- Philips Lighting. (2016, May). Philips edge case study. Somerset, New Jersey, United States of America. Retrieved from http://images.philips.com/is/content/PhilipsConsumer/CaseStudies/CALI20160114_001-UPD-en_AA-the-edge-amsterdam-connected-lighting-case-study-INT-DPS.pdf
- Randall, T. (2015, September 23). The smartest building in the world. *Bloomberg Businessweek*.
- Ronen, E., O'Flynn, C., Shamir, A., & Weingarten, A.-O. (2016, October). IoT goes nuclear: creating a Zigbee chain reaction. Retrieved from <https://eprint.iacr.org/2016/1047>
- Rouse, M. (2014, November). *Advanced Encryption Standard (AES)*. Retrieved from TechTarget Web Site: <http://searchsecurity.techtarget.com/definition/Advanced-Encryption-Standard>

- Rzadkosz, S. (2015, December). *A tale of five protocols*. San Francisco, California, United States of America.
- Seed Labs. (2015). *Introduction to smart lighting*. Retrieved from Silvair Web site: <http://bit.ly/1ETAL15>
- Silvair. (2016, March). *Adaptive lighting systems in the era of smart luminaires*. San Francisco, California, United States of America.
- The Connected Lighting Alliance. (n.d.). *About Us*. Retrieved February 18, 2017, from The Connected Lighting Alliance Web Site: <http://www.theconnectedlightingalliance.org/about-us/>
- Thread Group. (2015, July 13). *Thread stack fundamentals white paper*. Retrieved from Thread Group Web site: http://threadgroup.org/Portals/0/documents/whitepapers/Thread%20Stack%20Fundamentals_v2_public.pdf
- U.S. Department of Energy. (2017, January). *DOE solid-state lighting program overview brochure*. Retrieved from U.S. Department of Energy Web site: https://energy.gov/sites/prod/files/2017/01/f34/ssl-overview_jan2017.pdf
- U.S. Department of Energy Building Technologies Office. (2013, February). *Solid-state lighting overview brochure*. Retrieved from U.S. Department of Energy Web site: https://energy.gov/sites/prod/files/2014/04/f14/ssl-overview_brochure_feb2013.pdf
- U.S. Department of Energy. (n.d.). *Understanding LED color-tunable products*. Retrieved from U.S. Department of Energy Web site: <https://energy.gov/eere/ssl/understanding-led-color-tunable-products>
- UL. (2015, October 1). *Power over Ethernet lighting - evolution or revolution?* Retrieved from UL Web site: <http://library.ul.com/?document=power-over-ethernet-lighting&industry=lighting>
- USAI Lighting. (2015, May 16). *Circadian rhythm lighting*. Retrieved from USAI Lighting Web Site: <http://www.usailighting.com/circadian-rhythm-lighting>
- ZigBee Alliance. (2017). *Zigbee Alliance*. Retrieved from Zigbee Alliance Web Site: <http://www.zigbee.org/zigbeealliance/>

Appendix A - Permissions and Disclaimers

This section includes the permissions obtained for images used in the report. These permissions were either available online or obtained via email.

3/9/2017

RE: Permission to Use Images - Nicole Sabourin

RE: Permission to Use Images

Christopher Yahn <christopher.yahn@legrand.us>

Thu 3/2/2017 8:44 PM

To: Nicole Sabourin <nicolesab@ksu.edu>;

You are approved!

From: Nicole Sabourin [mailto:nicolesab@ksu.edu]

Sent: Thursday, March 02, 2017 2:27 PM

To: Christopher Yahn

Subject: Permission to Use Images

Hello Mr. Yahn,

I am the graduate student from Kansas State University studying Architectural Engineering that spoke with you on the phone. I would like to use two images found on the attached cut-sheet from Legrand's Wattstopper website in my Masters Report titled "The Effects of Connected Lighting on Lighting Controls and Design." The two images that I would like to use are outlined in red on the cut-sheet. I plan to use these graphics to show how current lighting control systems are typically laid out and how they are wired. I then plan to discuss connected lighting control solutions (particularly wireless) and how they might change lighting control system layouts. May I please have permission to use these images?

Please contact me if you have any questions.

Thank you,

Nicole Sabourin
Architectural Engineering Senior
Kansas State University

Disclaimer

This report was prepared as an account of work sponsored by an agency of the United States Government. Neither the United States Government, nor any agency thereof, nor any of their employees, nor any of their contractors, subcontractors, or their employees, makes any warranty, express or implied, or assumes any legal liability or responsibility for the accuracy, completeness, or usefulness of any information, apparatus, product, or process disclosed, or represents that its use would not infringe privately owned rights. Reference herein to any specific commercial product, process, or service by trade name, trademark, manufacturer, or otherwise, does not necessarily constitute or imply its endorsement, recommendation, or favoring by the United States Government or any agency, contractor, or subcontractor thereof. The views and opinions of authors expressed herein do not necessarily state or reflect those of the United States Government or any agency thereof.

This publication may be reproduced in whole or in part for educational or non-profit purposes without special permission from the copyright holder, provided acknowledgement of the source is made.

The document should be referenced as: *DOE SSL Program, "Connected Lighting Systems Meetings Report," October 12, 2016.*

DISCLAIMER

This report was prepared as an account of work sponsored by an agency of the United States Government. Neither the United States Government, nor any agency thereof, nor any of their employees, nor any of their contractors, subcontractors, or their employees, makes any warranty, express or implied, or assumes any legal liability or responsibility for the accuracy, completeness, or usefulness of any information, apparatus, product, or process disclosed, or represents that its use would not infringe privately owned rights. Reference herein to any specific commercial product, process, or service by trade name, trademark, manufacturer, or otherwise, does not necessarily constitute or imply its endorsement, recommendation, or favoring by the United States Government or any agency, contractor, or subcontractor thereof. The views and opinions of authors expressed herein do not necessarily state or reflect those of the United States Government or any agency thereof.

This publication may be reproduced in whole or in part for educational or non-profit purposes without special permission from the copyright holder, provided acknowledgement of the source is made. The document should be referenced as:

DOE SSL Program, "R&D Plan," edited by James Brodrick, Ph.D.

Contributors

Norman Bardsley
Monica Hansen
Lisa Pattison
Morgan Pattison
Kelsey Stober
Victor Taylor
Jeffrey Tsao
Mary Yamada

Bardsley Consulting
LED Lighting Advisors
SSLS, Inc.
SSLS, Inc.
Navigant Consulting, Inc.
Navigant Consulting, Inc.
Sandia National Laboratories
Navigant Consulting, Inc.