

Utah State University

DigitalCommons@USU

All Graduate Theses and Dissertations

Graduate Studies

5-1975

The Influence of Roots on the Accuracy of Soil-Moisture Measurements Taken with a Neutron Moisture Meter

Terry L. Andreessen

Follow this and additional works at: <https://digitalcommons.usu.edu/etd>

 Part of the [Water Resource Management Commons](#)

Recommended Citation

Andreessen, Terry L., "The Influence of Roots on the Accuracy of Soil-Moisture Measurements Taken with a Neutron Moisture Meter" (1975). *All Graduate Theses and Dissertations*. 6313.

<https://digitalcommons.usu.edu/etd/6313>

This Thesis is brought to you for free and open access by the Graduate Studies at DigitalCommons@USU. It has been accepted for inclusion in All Graduate Theses and Dissertations by an authorized administrator of DigitalCommons@USU. For more information, please contact digitalcommons@usu.edu.



9 JUN 1975

THE INFLUENCE OF ROOTS ON THE ACCURACY OF SOIL-MOISTURE
MEASUREMENTS TAKEN WITH A NEUTRON MOISTURE METER

By

Terry L. Andreessen

A thesis submitted in partial fulfillment
of the requirements for the degree

of

MASTER OF SCIENCE

in

Watershed Science

UTAH STATE UNIVERSITY
Logan, Utah

1975

ACKNOWLEDGMENTS

I wish to express my appreciation to the Intermountain Forest and Range Experiment Station of Logan, Utah, for their help and cooperation in the study.

Very special thanks are given to Mr. Bland Z. Richardson, research scientist, who made the study possible. Without his specially constructed equipment, his mechanical skills, and the many helpful hours he spent with me, this study would not have been successful.

I would also like to extend my appreciation to Dr. George E. Hart, chairman, Dr. Norbert V. DeByle, and Dr. Robert Oaks Jr., who along with Bland Z. Richardson served on my graduate committee. The guidance I received from these gentlemen proved very helpful throughout the study.

Finally, I would like to pay my regards to Mr. Terry Taylor for his assistance in setting up equipment and collecting data.

This study was financed by the McIntire-Stennis Cooperative Forestry Research Act under Utah State Agricultural Experiment Station Project 777.

Terry L. Andreessen

TABLE OF CONTENTS

	<u>Page</u>
INTRODUCTION	1
OBJECTIVES	4
REVIEW OF LITERATURE	5
Hydrogen content in roots	5
Factors of the environment which may influence the neutron method	5
DESCRIPTION OF EQUIPMENT	8
DESCRIPTION OF MATERIALS	12
PROCEDURE.	16
Placement of roots in the tank	16
Technique of filling the tanks to a uniform density	16
Changing the moisture content within the tanks	19
Procedure used in obtaining neutron moisture measurements	20
RESULTS AND DISCUSSION	21
Effects of root size	21
Effects of distance between tube and root	26
SUMMARY AND CONCLUSIONS	31
LITERATURE CITED	34
VITA	35
APPENDIX	36

LIST OF TABLES

<u>Table</u>	<u>Page</u>
1. Description of soil media	12
2. Description of root material (Experiment I)	13
3. Description of root material (Experiment II).	13
4. Maximum Measurement Errors (In percent Moisture by Volume	32

LIST OF FIGURES

<u>Figure</u>	<u>Page</u>
1. One of the tanks use in the study	9
2. Funnel and two Tyler screens used in dispersing the sand	11
3. The two root sections used in Experiment I	14
4. Placement of roots within the sample tank for Experiment I	17
5. Placement of roots within the sample tank for Experiment II.	18
6. Curve for dry conditions (Experiment I)	21
7. Curve for saturated conditions (Experiment I)	22
8. Curve for drained conditions (Experiment I)	23
9. Curve for dry conditions (Experiment II)	27
10. Curve for saturated conditions (Experiment II)	28
11. Curve for drained conditions (Experiment II)	29

ABSTRACT

The Influence of Roots on the Accuracy of Soil-Moisture
Measurements Taken with a Neutron Moisture Meter

By

Terry L. Andreessen, Master of Science

Utah State University, 1975

Major Professor: Dr. George E. Hart
Department: Forestry and Outdoor Recreation

The effects of roots on soil-moisture measurements taken with a neutron probe were studied. These effects were observed under three different soil-moisture conditions, with different sized roots, and with varying distances between the access tube and root. The moisture conditions used were air dry, field capacity, and saturated.

Large roots can greatly affect neutron soil-moisture measurements when the access hole is drilled through the root. Positive errors as large as 52 percent were found when the soil moisture was at field capacity. With dry and saturated conditions positive errors of 43 percent and 38 percent respectively, were found.

In most practical field situations, where the access hole is not drilled through large roots, root material appears to have very little effect, if any, on neutron soil-moisture measurements. The largest positive error found, when the access holes were not drilled through the roots, was only 8 percent. This occurred at a point where the access tube was in contact with the outside of a root.

(48 total pages)

INTRODUCTION

The neutron method of measuring soil moisture evolved from a need to follow moisture changes in the soil without resorting to destructive sampling. The neutron method satisfies this need by providing a fixed location where depth-moisture readings may be made whenever desired and needed. A properly installed access tube causes no substantial disturbance to the strata involved and can be left in place without disturbing the drainage or other characteristics of the surrounding terrain. Any difference in reading through time at a location is attributed to soil-moisture change and not to soil variations as could happen in gravimetric sampling.

Studies have shown that moisture readings with the neutron method are relatively independent of soil type; therefore, the need for only one calibration curve is an advantage. Other advantages include the fact that the moisture readings obtained represent an average over a larger sample area and is a measure of all the states (solid, liquid, or vapor) of water.

Some of the disadvantages associated with the neutron method are:

- (1) The initial cost of the equipment is high.
- (2) The necessity for access holes and tubing to position the probe within the soil may present problems depending upon the soil type and rock content encountered.
- (3) Accuracy is reduced at a high moisture content.

Without getting into too much detail, it is felt that a brief description of the operational theory of the neutron method will facilitate an

understanding of the method. The depth-moisture probe emits fast, or fission neutrons, from a radium-beryllium source, into the soil. These fast neutrons are then slowed down as a result of elastic collisions, the fast neutrons are reduced to slow neutrons. A small quantity of the slowed neutrons are backscattered toward the counter, or detector region of the probe, and are detected. The number of slow neutrons detected is proportional to the concentration of the hydrogen nuclei in the soil; and with proper calibration of the moisture probe, the moisture content by volume of the soil may be obtained.

The detector portion of the tube that is sensitive to slow neutrons contains boron trifluoride gas, and after absorbing a neutron, a boron¹⁰ atom emits an alpha particle and an atom of lithium⁷. Both of these recoil particles are highly ionized and a large pulse is produced. These pulses or signals are then amplified by a preamplifier, driven through a cable and recorded on a scaler.

The three primary factors which can produce errors in moisture measurements using the neutron method are: (1) voids (air-gaps) around the access tube, (2) organic matter present in the soil, and (3) chemical substances within the soil. Other than soil water itself, organic matter is the most important source of hydrogen in the soil.

Because root material is organic matter, this study will investigate whether roots influence the neutron moisture readings and, if so, determine the effects of root size and the distance between the roots and the access tube.

Very little work has been done to determine the effects root material may have on neutron moisture readings. The results and discussion that follow will hopefully contribute considerably in providing scientists

a better understanding of the neutron method as a tool for soil-moisture measurement in a wildland situation.

OBJECTIVES

This study has two objectives: (1) To determine if root material can affect soil-moisture measurements made by the neutron scattering method; and (2) To determine what influence root size, as well as distance between the access tube and root material, may have on the effects of roots on the neutron-moisture readings.

REVIEW OF LITERATURE

Hydrogen content in roots

Ehlers et al. (1969) state that organic material is the second most important source of hydrogen in the soil, with water being the most important. The hydrogen content of humus is about 5 percent of its weight, whereas the amount of hydrogen in water is about 11 percent of its weight. Therefore, the amount of hydrogen in soil organic matter may be an appreciable part of the total hydrogen. However, soils containing much organic matter also contain large amounts of water and, therefore, the hydrogen content of the organic material is usually small in comparison to soil water and normally will have a negligible effect on the scattering and slowing of neutrons. Although root material is not specifically mentioned, it does give us some indication of organic matter in general.

Factors of the environment which may influence the neutron method

After a considerable search of the literature, I found no material which specifically pertained to the effects of roots on neutron-moisture readings. However, a limited amount of literature was found concerning the effects of voids, chemicals, and stones on the neutron method.

Richardson and Burroughs (1970) have probably done the most notable work with voids and their effects. Two soil tanks were constructed with one having two voids of known size installed and the other one remaining a control. The rest of the design and procedure of their experiment was similar to the one described within this thesis.

Richardson and Burroughs measured the percent error caused by voids at different levels of soil-moisture. When a void was saturated due to a high water level, the largest positive error was obtained. Positive errors as large as 70 to 75 percent were found when the surrounding soil was saturated and the voids filled with water. As the water level fell, or decreased, within the voids, the magnitude of the positive error also decreased. When the voids were empty negative errors occurred, with the maximum being 13 percent. The magnitude of the negative error was much less than the positive errors obtained from a saturated void.

These results somewhat substantiate the earlier work by Burroughs (1966). He found that in the summer, when the soil is dry, voids introduce only a negligible error in the neutron moisture readings. However, when the water table rises and saturates the voids, much larger errors are caused.

The experiment by Richardson and Burroughs indicated that the larger the void, the greater the magnitude in errors introduced. Concerning this facet of the problem, Troxler (1963) suggested that 0.15 inch is the maximum air gap which can be tolerated without error.

Stones of varying size have also been known to affect the accuracy of the neutron scattering method. Reinhart (1961) found by gravimetric sampling that stones reduce the actual moisture present in a given volume. As soil moisture increases, a larger error is introduced when stones are present. This results in a lower indication of soil moisture than actually exists in the soil itself. Stones have few, if any, hydrogen atoms, and no conversion of fast neutrons to slow neutrons occurs within the volume of rocks. The net result is an apparently lower moisture content.

The chemistry of soil may also introduce an error into the neutron technique when taking soil-moisture measurements. Cotecchis et al. (1968) discovered that hydrogen is not the only element capable of slowing and scattering fast neutrons. They found that soils high in boron, chlorine, cadmium, lithium, and other elements indicate a soil-moisture higher than what actually exist when using the neutron-scattering method. The above elements appear to have the same capabilities as hydrogen, insofar as slowing down fast neutrons.

Soil-moisture measurements taken near the soil surface with the neutron probe may be another source of error. Near the soil-air interface, neutrons moving upward may be lost into the air, thus lowering the density of slow neutrons around the detector portion of the probe. Ziemer et al. (1967) found that the depth of the source at which the soil-air interface no longer influenced the soil-moisture readings was 8.7 inches from the soil surface.

DESCRIPTION OF EQUIPMENT

The neutron probe and scaler was manufactured by Troxler Electronic Laboratories, Incorporated, Raleigh, North Carolina. The source of radiation in the probe is 3 m.c. (millicuries) of radium-beryllium, with the detector portion of the probe containing boron trifluoride gas. All equipment and facilities used in this study were provided by the Intermountain Forest and Range Experiment Station, Logan, Utah.

The seven elements that make up the system are a fast-neutron source, radiation shielding, a boron trifluoride detector which is sensitive to slow neutrons, a preamplifier, housing for the parts, a cable connector for attachment to the counter, and a Model 200 B scaler, or counter.

The two tanks which were used were 30 inches in diameter and 68 inches in height, one of which is shown in Figure 1. One tank was used as a control while the other was used as a treatment tank. They were constructed of plexiglass, and attached to a steel base with eight 1/2-inch support rods inserted in the base. These rods extended the entire height of the tank and protruded about 4 inches beyond the top of the tank. A round steel plate 1/8-inch thick was placed on top of the tank and bolted to the eight support rods. Along with this, four bars were bolted on top of the steel plate so that the hoist used in the study could be attached to the tanks. A drain with a valve and filter were placed in the bottom of the tanks to provide facilities for filling the tanks with water and also for draining them.

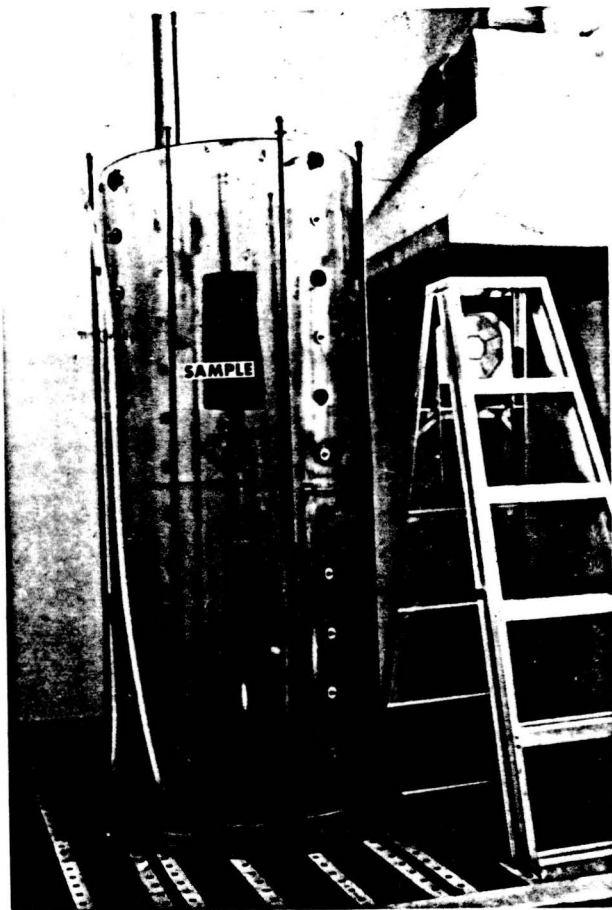

Figure 1. One of the tanks used in the study.

A hydraulic jack was supported on a steel beam directly above the tanks and was mounted on rollers so that the jack could be moved from one tank to another. The beam itself was supported by two A-frames, one located at each end of the beam.

The equipment used in filling the tanks with sand was a 55-gallon drum with a valve placed in the bottom to regulate the flow of sand. A 4.00 mm. and 5.61 mm. Tyler screen were placed together and then inserted into a funnel. The funnel, in turn, was attached to a section of vacuum hose which was placed in the valve in the bottom of the drum (Figure 2). The equipment was assembled in such a way that the sand flowed from the drum, through the hose, into the funnel and was dispersed through the two screens into the tank.



Figure 2. Funnel and two Tyler screens used in dispersing the sand.

DESCRIPTION OF MATERIALS

The soil media used in this study was made up of sand sieved specifically to a size class of .5 mm. to 2.0 mm. The sand was air dry when put into the tanks and relatively free of any foreign soil particles. The volume, weight and bulk density of the sand within each tank are listed below in Table 1.

Table 1. Description of the soil media

Tank	Volume	Weight	Bulk Density
Control	732,921.6 cm. ³	1,160,308.8 gm.	1.589 gm/cm ³
Sample	720,460.8 cm. ³	1,154,895.3 gm.	1.592 gm/cm ³

In Experiment I, two root sections were cut from a sub-alpine fir (Abies lasiocarpa), which had been blown over a couple months before, but whose needles were still green. Two-inch cores were drilled out of the center of both root sections used. After the cores were drilled in the roots various measurements were made, as shown in Table 2.

Table 2. Description of root material (Exp. I)

Root	Wet wt.	Oven-dried wt.*	% moist. by wt.	Volume	Wet Density
Large	4627 gm.	2742 gm.	68.7	6256 cm ³	.740 gm/cm ³
Small	2118 gm.	1349 gm.	57.0	2901 cm ³	.730 gm/cm ³

* Dried for 24 hours after experiment was run

Each section was approximately 15 inches in length, with the larger one having a diameter of 6 to 7 inches and the smaller one being 3 to 4 inches in diameter (Figure 3).

In Experiment II, three root sections were cut from a root of a live sub-alpine fir. The measurements for the three root sections are shown in Table 3. The greater bulk density of the roots in Experiment II as compared to those used in Experiment I was due to the fact that the root section cut for Experiment II was fresher and contained more water.

Table 3. Description of root material (Experiment II)

Root	Length	Width	Volume	Wet Weight	Wet Density
#1 (Top)	29.8 cm.	7.6-8.9 cm.	1815 cm ³	1811 gm	.998 gm/cm ³
#2 (Middle)	29.8 cm.	7.6-8.9 cm.	1780 cm ³	1790 gm	1.006 gm/cm ³
#3 (Bottom)	29.8 cm.	7.6-8.9 cm.	1845 cm ³	1921 gm	1.041 gm/cm ³

As shown in the Tables 1, 2, and 3, there was very little variance in the material used for each experiment, which would indicate the



Figure 3. The two root sections used in Experiment 1.

results obtained are valid pertaining to the objectives of this study. The bulk density of the sample tank in Experiment II was assumed to be the same as in Experiment I due to the uniform process of filling the tank with sand.

PROCEDURE

Placement of roots in the tank

Different methods were used in placing the roots in the sample tank for the two experiments in the study. In Experiment I the two root sections, with 2-inch cores drilled out of the center, were pushed onto the access tube and placed at pre-determined depths in the tank (Figure 4). Each root section was sealed on the cut ends, as well as being sealed to the tube, with a thin layer of silicone rubber. The silicone prevented water from seeping in between the root and the tube and also kept it from entering the open pores of the woody section of the root, both of which may have caused erroneous readings.

For Experiment II the three root sections were placed horizontally at three pre-determined depths in the sample tank as it was being filled, with the side of the root sections lying perpendicular to the tube (Figure 5). The side of the top root was touching the tube, the middle root was 2 inches from the tube, and the bottom one was 4 inches away. The ends of these sections were also sealed with a layer of silicone rubber.

Technique of filling the tanks to a uniform density

When filling both the sample tank and control tank, the drum apparatus, described previously was supported above the tanks by an electric hoist. Sand was then placed in the drum and the valve opened to the point where sand would fall from the screens in a uniformly dispersed

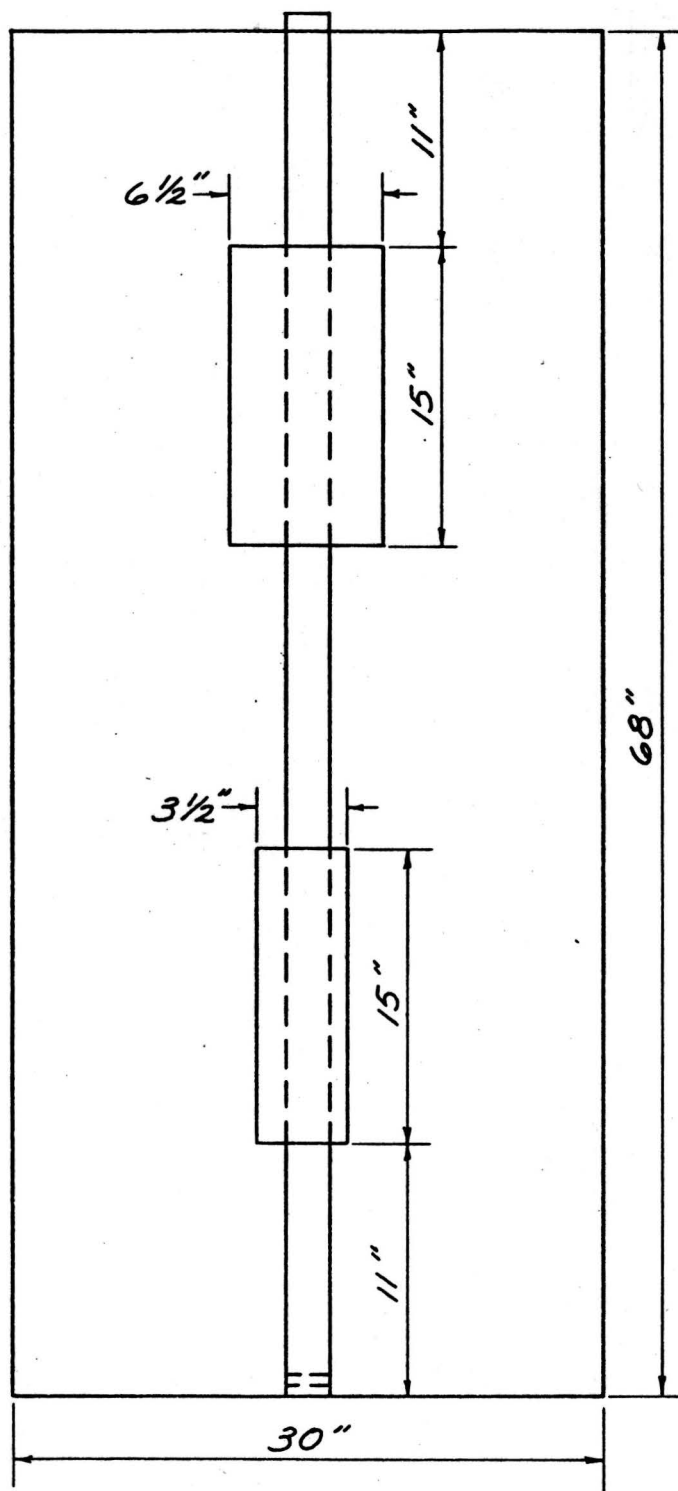

Figure 4. Placement of roots within the sample tank for Experiment 1.

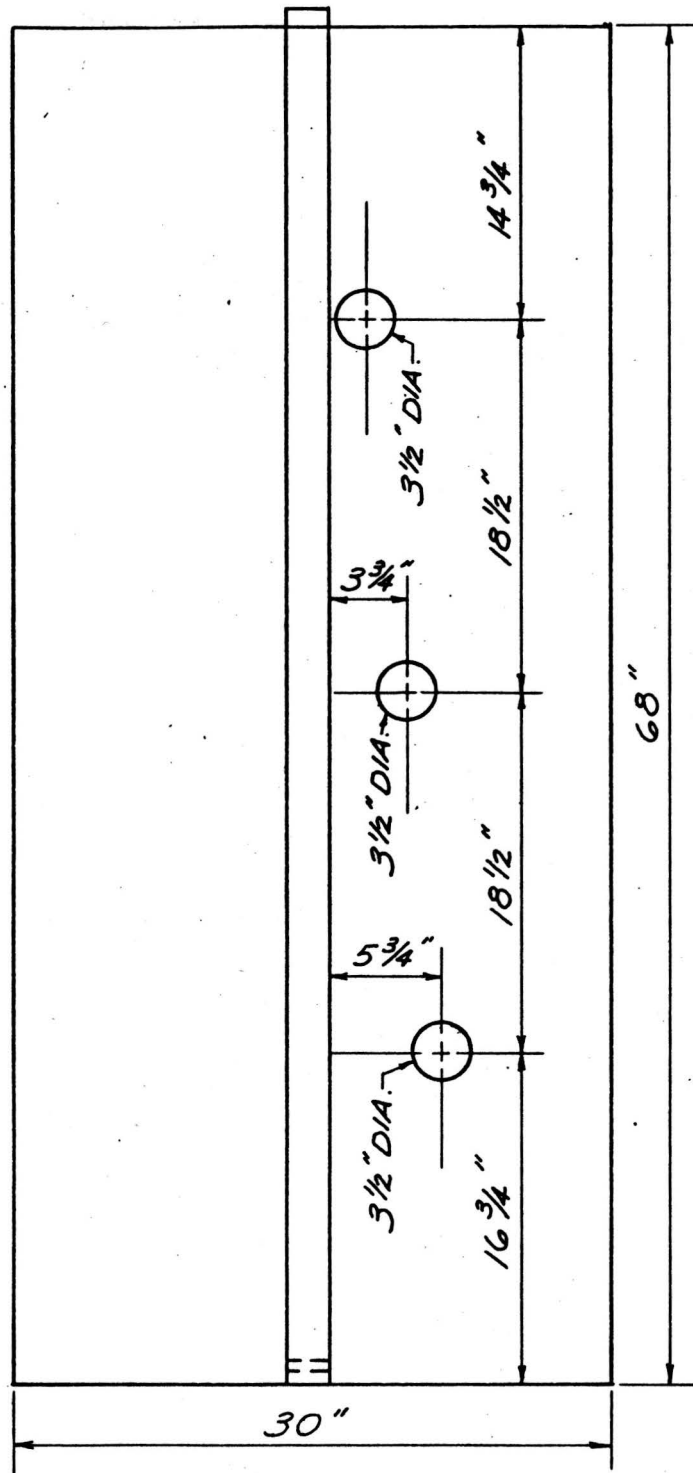

Figure 5. Placement of roots within the sample tank for Experiment II.

fashion (Figure 2). The same bulk density is needed in both tanks in order to obtain the same moisture by volume in both tanks at the different soil-moisture levels.

This manner of filling gives the sand within the tanks a uniform density throughout, as indicated in a previous section. Further details concerning this procedure can be found in a paper by Richardson and Burroughs (1972).

Changing the moisture content within the tanks

In both experiments, probe readings were taken at three different soil-moisture levels within the tanks. The three moisture levels used were air dry (.1 percent), saturated (42 percent), and field capacity (6 percent by volume). Since the sand had less than .1 percent moisture by volume when it was placed in the tanks, there was no problem in getting the air-dry readings.

To obtain saturated conditions, a hose was placed on the drain valve at the base of the tank and water was then forced upward through the filter in the bottom of the tank and into the sand. The water saturated the sand from the bottom to the top thereby forcing out any air in the tank through air holes drilled in the steel plate located on top of the tank. Water was allowed to enter until it started seeping out the top of the tank, which took approximately two hours.

In obtaining the field capacity conditions, a hose was once again connected at the drain valve located at the base of the tanks and the water was allowed to drain for 24 hours. At the end of 24 hours the water ceased to drain except for an occasional drip. This indicated that most of the free water had drained off, and the soil was very close

to field capacity. In saturating and draining the tanks, both the control and sample tanks were done simultaneously.

Procedure used in obtaining neutron moisture measurements

Two pulleys were placed above each tank from which the probe and cable were suspended. This pulley system allowed the probe to be lowered and raised easily by pulling down, or letting up, on the opposite end of the cable that was attached to the scaler.

Marks were made on a 2 x 4 board that was attached vertically, to each end of the A-frame near the side of the tanks. These marks corresponded directly to desired positions the probe was to be placed in the tanks. A clamp, which was attached to the 2 x 4, was used to keep the probe and cable in place while readings were being made.

Different depths were required for the probe in Experiment II than were needed in Experiment I, due to the placement of the roots for each experiment. The positions at which readings were taken for each experiment can be seen in Figures 6 and 9. For each position at which the probe was placed in the tanks, a one-minute count was taken and recorded from the scaler. These counts were then converted to percent moisture by volume from a calibration curve recently re-checked by W. F. Troxler.

RESULTS AND DISCUSSION

Effects of root size

As shown in Tables 1 and 2, the difference in bulk density of the sand in the two tanks and the wet density of the two root sections was negligible in Experiment I. The bulk density in the two tanks differed by only 1.3 percent and the wet density of the two root sections differed by 1.4 percent.

Percent moisture by volume in the two tanks at a given soil-moisture level was plotted on a graph. The depth at which the measurement was taken in the tanks is plotted on the ordinate, and the percent moisture by volume on the abscissa. The total effect of the root sections on a specific moisture reading made at a given depth is the difference measured horizontally between the two curves. This difference is referred to as measurement error and is expressed as percent moisture by volume. The maximum measurement error for each root is stated on each figure.

As shown in Figures 6, 7 and 8, the sample curve returned to the control curve, or closely approached it between the two root sections. This indicates that the two root sections were out of the sphere of influence of each other.

Figures 6, 7 and 8 indicate that the greatest maximum errors for both roots were found in the drained conditions, which was approximately field capacity. Interestingly enough, the greatest difference in maximum error between the large root segment and small root segment was

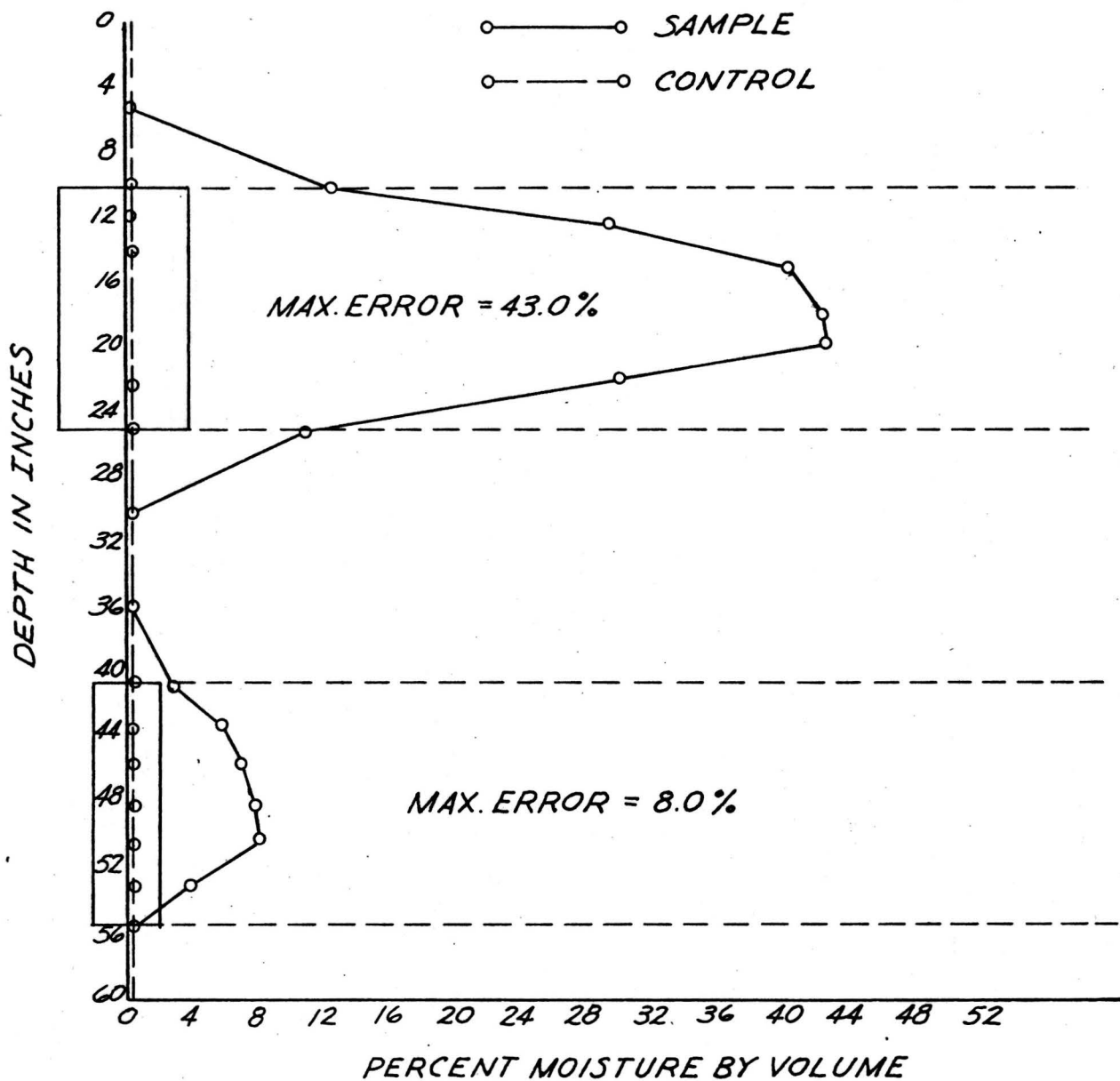

Figure 6. Curve for dry conditions (Experiment I).

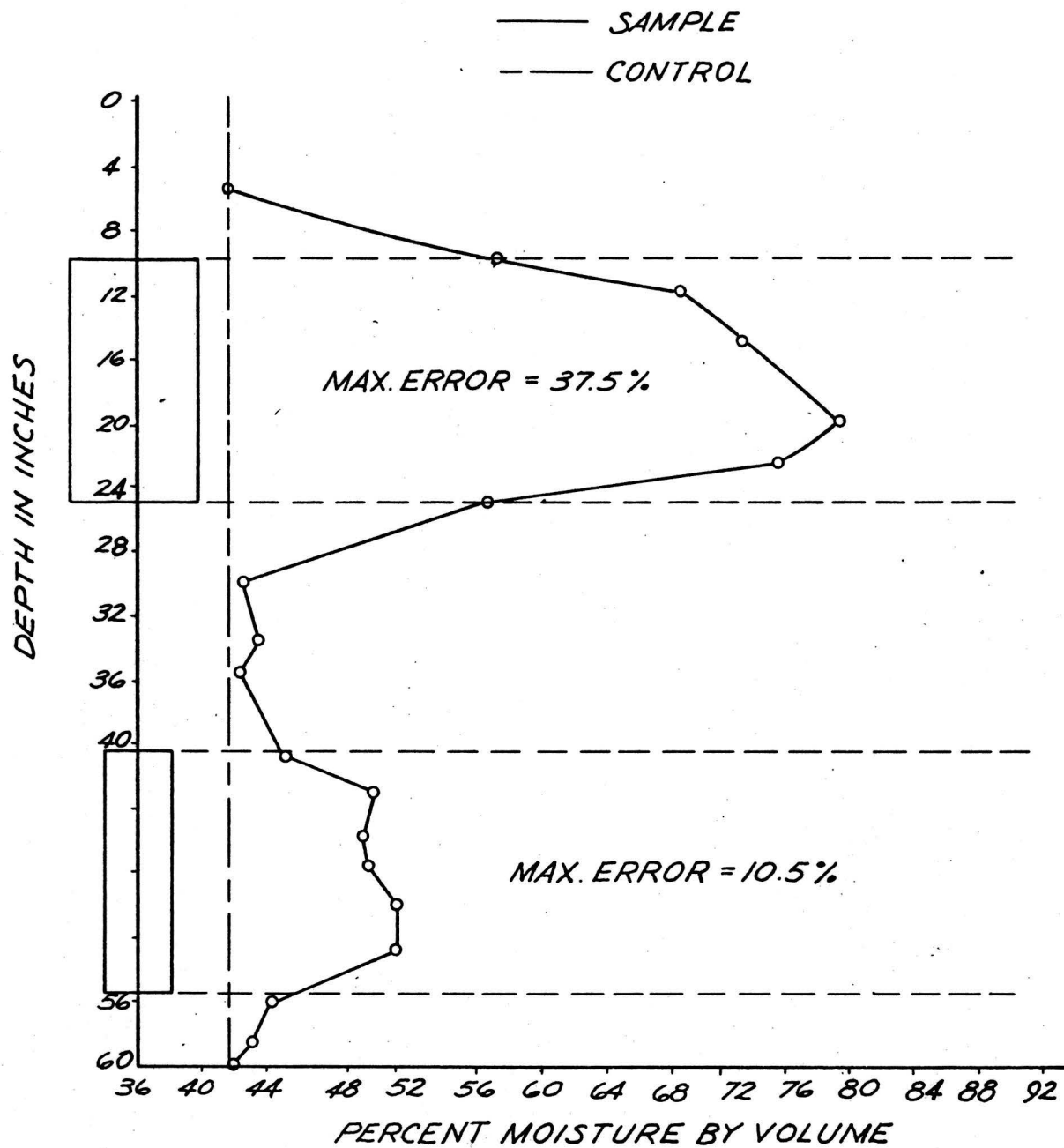

Figure 7. Curve for saturated conditions (Experiment I).

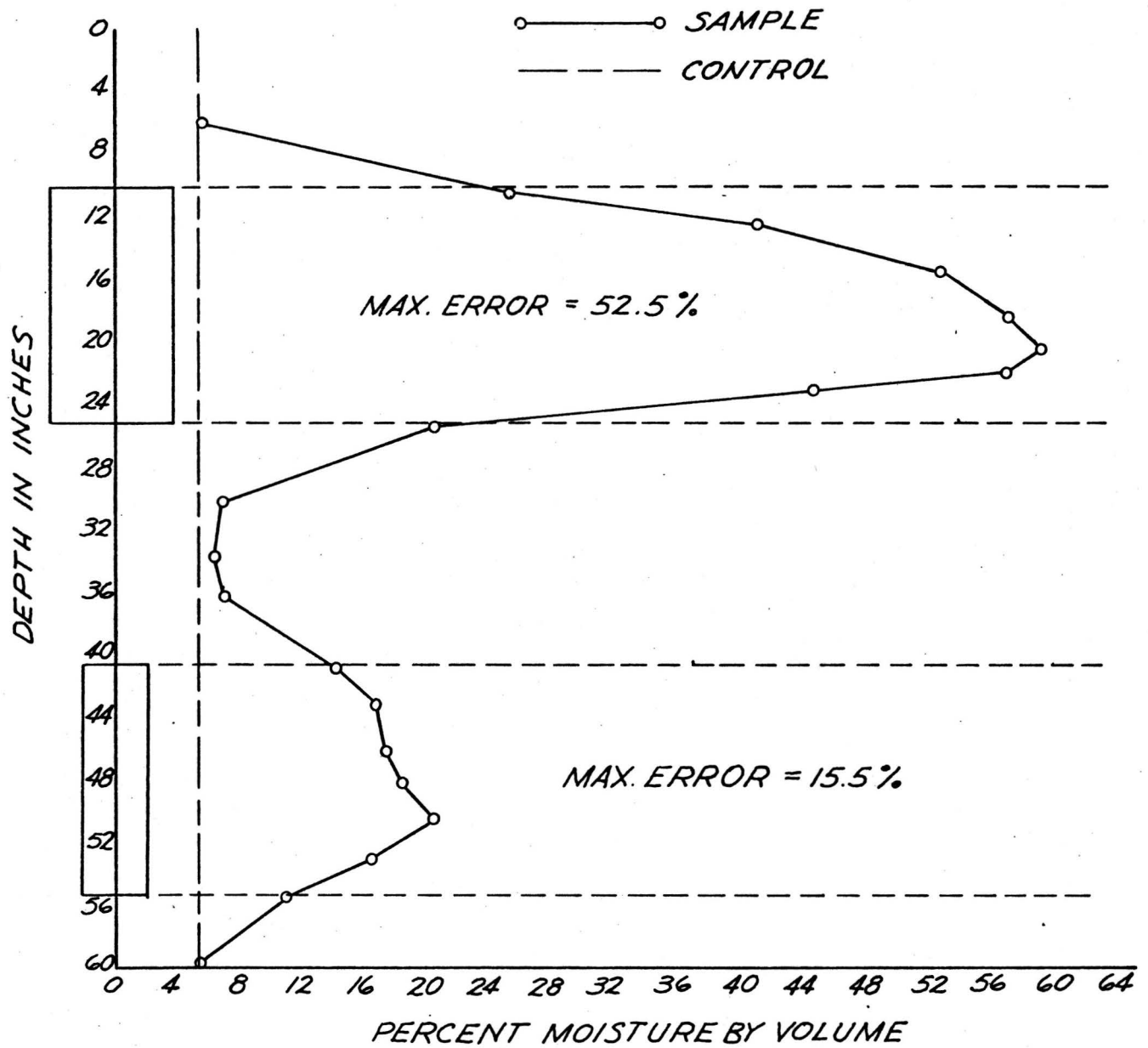

Figure 8. Curve for drained conditions (Experiment I).

also found at drained conditions.

It should be noted that the measurement error for the small root was only 19 percent of the measurement error for the large root under dry conditions, 28 percent under saturated conditions, and 30 percent under drained conditions. This indicates that although the smaller root was almost half the volume of the larger root, the measurement errors were not proportional to the root volume. There may be several possible explanations for these results; however, I believe the primary reason is related to the sphere of influence.

Another factor which may enter into the situation is that the large root had a moisture content of 69 percent by weight, whereas the small root contained 57 percent by weight, as shown in Table 2.

The two peaks which appear on the curve for the smaller root section, particularly in Figure 7, deserve further explanation. The shape of the small root section was such that the root was smaller in diameter in the middle and larger on the ends. It is my opinion that its physical shape is the basic reason for the apparent two peaks.

After observing the results of Experiment I, it is clear that root material does affect the neutron soil-moisture measurements to a large degree when the access tube is drilled through the root. This condition could only hold true in a field situation where access holes were drilled through, or partly through, taproots and larger lateral roots in a forested area. Although Experiment I does not offer much toward field application, it does fulfill the first objective of this study; namely, it shows that root material does affect soil-moisture measurements made with the neutron-scattering method. It does not, however, provide information on the effects of all species or sizes

of roots.

Effects of distance between tube and root

The results obtained from Experiment II were considerably different than those in Experiment I, as seen in Figures 9, 10 and 11. The only resemblance that the results from the two treatments have is that the greatest maximum error always occurred under drained conditions, approximately field capacity.

It is safe to assume from Figure 9 that roots not touching the access tube under extremely dry soil conditions, in sandy soil, have no measurable influence on the neutron moisture measurements. I believe it is also safe to assume that unless the root touching the tube is of large size, such as the ones used in Experiment II, it will have very little influence under dry soil moisture conditions. It is possible that a large mass of smaller roots in very close proximity to the tube may have the same effect as one larger root, but this cannot be substantiated from this experiment.

Under saturated conditions for Experiment II, all three root sections had a slightly greater influence on the measurements than they did under dry conditions (Figure 10). One possible explanation for this is the fact that under saturated conditions the sphere of influence is very much smaller than under dry conditions and, therefore, the root sections take up a greater portion of the sphere. By occupying a greater portion of the sphere of influence the root section has a greater effect on the reading. The fact that the point of maximum error occurs at the top of the root (Figure 10) is due to the geometry of the source detector within the neutron probe as discussed by Schultz (1967).

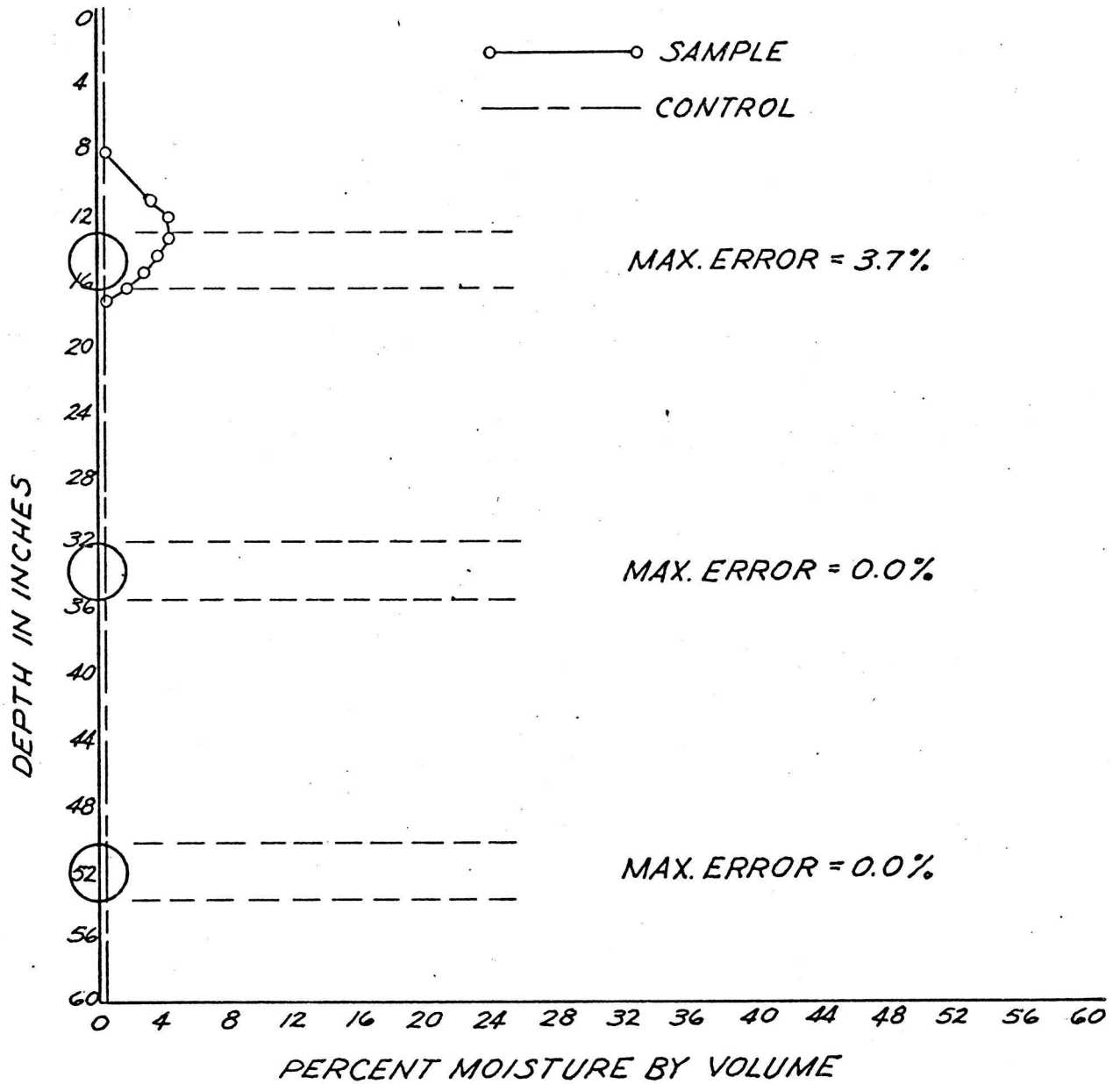

Figure 9. Curve for dry conditions (Experiment II).

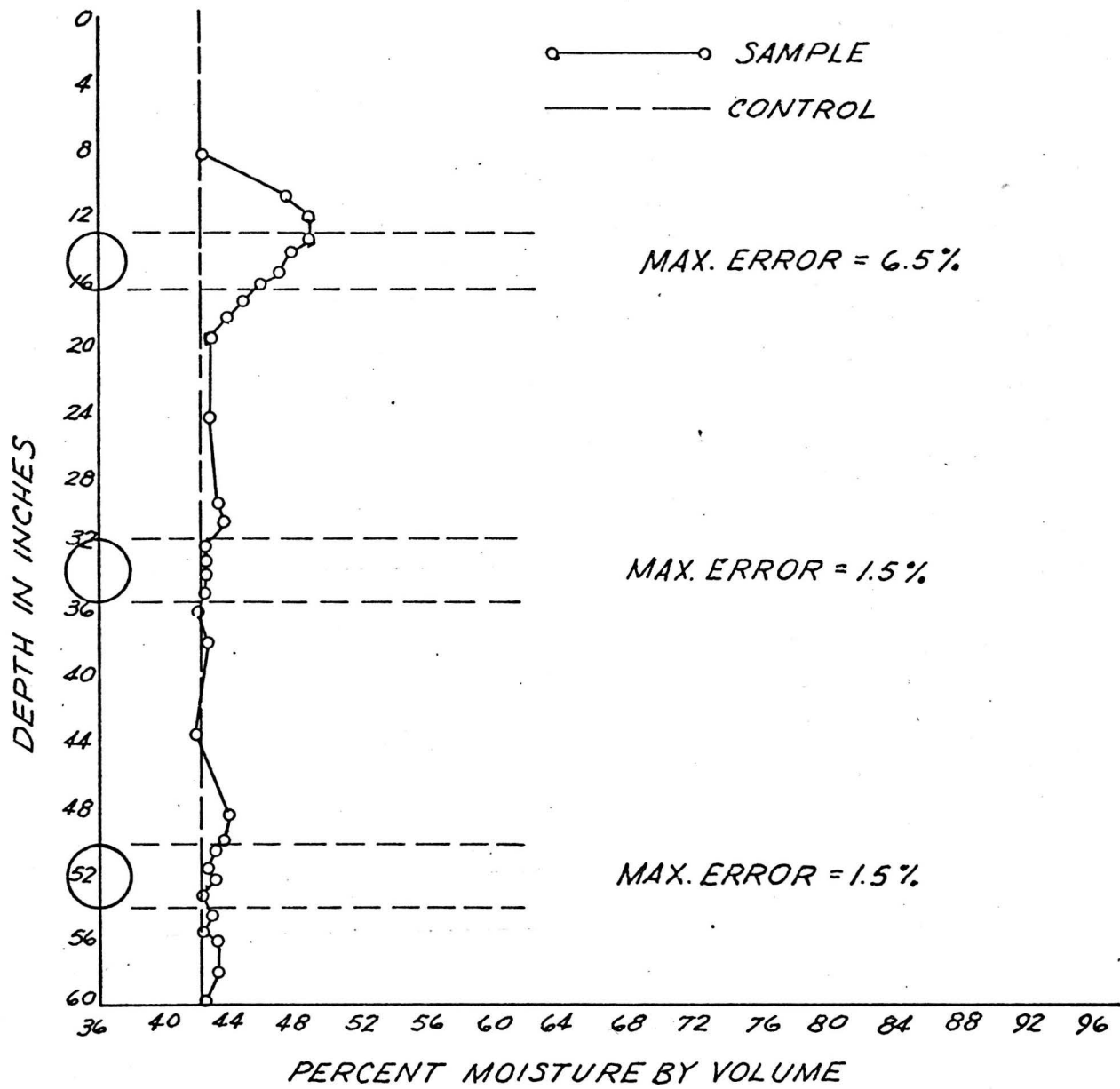

Figure 10. Curve for saturated conditions (Experiment II).

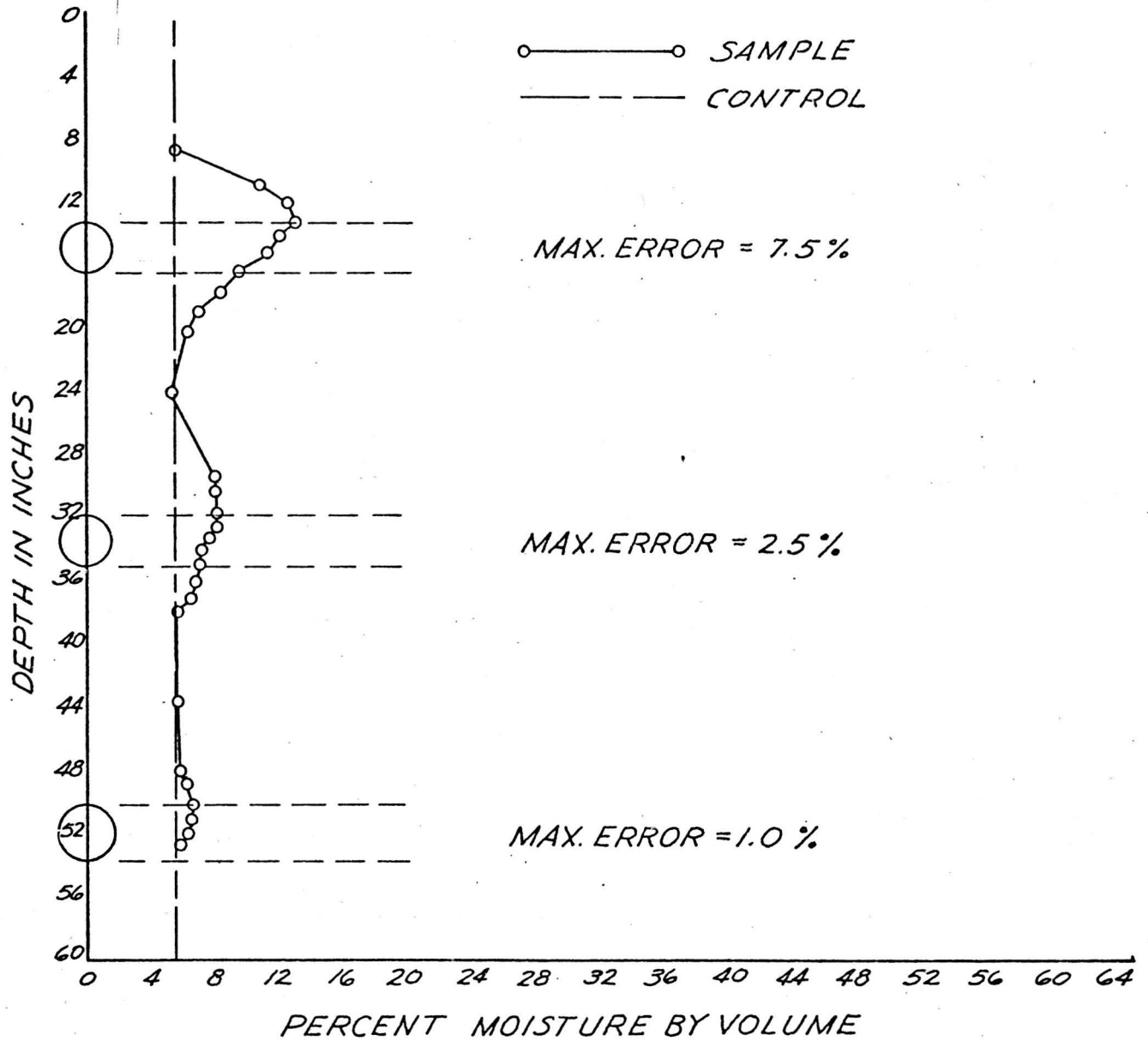

Figure 11. Curve for drained conditions (Experiment II).

The roots that weren't touching the tube, under saturated conditions, have a minimal effect on the measurements, whereas the upper root section that was touching showed a maximum error of 6.5 percent (Figure 10). Under saturated conditions, in a sandy soil, we can again assume that unless very large roots are touching, or in very close proximity to the tube, there will be no important influence.

The results obtained using drained conditions (Figure 11) show somewhat the same pattern as the two previous soil-moisture conditions, with a slightly greater maximum error for the two root sections closest to the tube. However, the results for the drained conditions do indicate that large roots may not have to be in contact with the tube to be slightly influential. They may be as far as 1 to 2 inches away and still show a small effect on the neutron measurements.

In general, it can be assumed from the results of Experiment II that large roots which are not in direct contact with the access tube have very little influence on neutron soil-moisture measurements under most soil-moisture conditions in a sandy soil. Even when large roots are in contact with the tube the greatest maximum error was only 7.5 percent.

Throughout the entire study the greatest maximum error occurred under drained conditions, without exception. The reason for these results is not clear to me. A possible explanation is that a capillary action by the water along the sides of the root may have occurred resulting in somewhat of a thin shield of water on the outside of the root. It may also have to do with the sphere of influence of the probe itself.

SUMMARY CONCLUSIONS

Table 4 summarizes the results of the study. From this table we can see that although Experiment I does not offer much toward practical field situations, it proves very definitely that root material can affect neutron soil-moisture measurements to a large degree. Drilling access holes through large lateral roots or tap roots is unlikely to happen under field conditions, but it is possible. If one is taking soil-moisture measurements in a heavily forested area and one or two of the readings are much larger than the rest, the possibility of having drilled through a large root must be investigated.

Unless the access holes are drilled through a larger root, however, it is concluded from this study that root material has little or no significant effect on neutron moisture measurements. Even when a large root is in close contact with the access tube it has relatively little influence, as shown in Table 4. In general, root material is not a factor to be overly concerned with in most wildland situations. Other inherent variabilities of soil-moisture measurements, such as voids and stones, should receive much more attention and concern.

Although the neutron probe over-estimated percent moisture values under saturated conditions than in drained or dry conditions, the greatest maximum errors occurred with drained conditions (approximately field capacity) in both experiments.

Table 4 indicates that the different sized roots used in Experiment I accounted for a large proportional difference in maximum errors, as

Table 4. Maximum Measurement Error (in Percent Moisture by Volume)

<u>Experiment I (tube drilled through root)</u>			
	Dry Conditions	Saturated Conditions	Drained Conditions
Large Root	43.0%	37.5%	52.5%
Small Root	8.0%	10.5%	15.5%
<u>Experiment II (roots placed at distances from tube)</u>			
	Dry Conditions	Saturated Conditions	Drained Conditions
Root touching tube	3.7%	6.5%	7.5%
Root 2" away	0.0%	1.5%	2.5%
Root 4" away	0.0%	1.5%	1.0%

well as in the total moisture readings between them. Part of this difference may be due to the fact that the larger root section contained a higher percent moisture by weight than did the smaller root section. It is also possible that a relationship exists between the size of the root section and the proportion of sphere of influence of which the root absorbs. An accurate explanation cannot be reached from the results of this study.

I believe this study has basically answered the questions for which it was set up for. However, roots from various other species of plants may affect moisture readings with the neutron probe differently. This could only be answered by conducting similar studies with different plant species. As a result of this study, however, I believe that under field situations, root material plays a very minor roll in inducing measurement error into neutron moisture readings.

LITERATURE CITED

- Burroughs, E. R. Jr. 1966. A study of the effect of logging roads on the soil mantle hydrology of a spruce-fir forest. M. S. Thesis. Montana State University, Bozeman, Montana. 120 p.
- Cotecchia, V., A. Inzaghi, E. Pirastru, and R. Ricchena. 1968. Influence of the physical and chemical properties of soil on measurements of water content using neutron probes. *Water Resources Re.* 4(5):1023-1028.
- Ehlers, C. J., L. C. Reese, and J. N. Anagnos. 1969. The nuclear method of soil-moisture determination at depth. The University of Texas, Austin, Texas. Incomplete. 66 p.
- Reinhart, K. G. 1961. The problem of stones in soil-moisture measurement. *Soil Science Society of America, Proceedings*, 25:268-270.
- Richardson, B. Z. and E. R. Burroughs. 1972. The effect of air gaps and saturated voids on neutron soil moisture measurements. *Intermountain Forest and Range Experiment Station, U. S. Forest Service Research Paper, INT-120*. 20 p.
- Schultz, J. D. 1967. Soil moisture measurement by the neutron method, p. 791-796. In *Sopper and Lull (Ed.) International Symposium on Forest Hydrology, 1967*. Pergamon Press Inc., New York, N.Y.
- Troxler, W. F. 1963. Calibration of nuclear meters for measuring moisture and density. *American Society for Testing and Materials, Special Technical Publication 351*. 13 p.
- Ziemer, R. R., I. Goldberg, and N. A. MacGillivray. 1967. Measuring moisture near soil surface. *Pacific Southwest Forest and Range Experiment Station, U. S. Forest Service Research Note PSW-158*. 6 p.

APPENDIX

EXPERIMENT I

Air Dry (Control)			Air Dry (Sample)		
Depth (inches)	Probe Reading	% Moisture by Volume	Depth (inches)	Probe Reading	% Moisture by Volume
0	80	.1	0	72	.1
5	109	↓	5	352	.1
10	169		10	3315	14.8
12½	167		12½	6059	30.6
15	228		15	7677	39.9
17½	208		17½	8146	42.6
20	216		20	8201	42.9
22½	212		22½	6216	31.5
25	232		25	2690	11.2
30	232		30	404	.1
33½	230		33½	348	.1
35½	226		35½	387	.1
40½	222		40½	1246	2.9
43	212		43	1718	5.6
45½	221		45½	1909	6.7
48	227		48	2022	7.4
50½	228		50½	2063	7.6
53	191		53	1363	3.6
55½	221		55½	705	.1
58½	204		58½	350	.1

Average Standard Count Before
12023

Average Standard Count After
12238

EXPERIMENT I

Saturated (Control)			Saturated (Sample)		
Depth (inches)	Probe Reading	% Moisture by Volume	Depth (inches)	Probe Reading	% Moisture by Volume
0	3125	13.7	0	3077	13.4
5	7612	39.5	5	7670	39.8
10	7716	40.1	10	9935	58.5
12½	7861	40.9	12½	11210	69.0
15	7753	40.3	15	11647	73.0
17½	7692	39.9	17½	12010	76.5
20	8034	41.9	20	12302	79.0
22½	7992	41.7	22½	11928	75.5
25	8220	43.0	25	9839	57.5
30	8053	42.0	30	8157	42.6
33½	8119	42.4	33½	8253	43.2
35½	7890	41.1	35½	8089	42.2
40½	7885	41.1	40½	8541	44.8
43	7982	41.6	43	8889	50.5
45½	8057	42.0	45½	8771	49.5
48	8077	42.2	48	8814	50.0
50½	8130	42.5	50½	9031	51.5
53	8057	42.1	53	9001	51.5
55½	7793	40.5	55½	8491	44.5
58½	7741	40.2	58½	8269	43.3

Average Standard Count Before
11969

Average Standard Count After
12176

EXPERIMENT I

Drained 24 hrs. (Control)			Drained 24 hrs. (Sample)		
Depth (inches)	Probe Reading	% Moisture by Volume	Depth (inches)	Probe Reading	% Moisture by Volume
0	278	.1	0	301	.1
5	977	1.4	5	1256	3.0
10	1428	4.0	10	5051	24.8
12½	1581	4.8	12½	7711	40.1
15	1631	5.1	15	9117	52.0
17½	1697	5.5	17½	9595	56.0
20	1698	5.5	20	9887	58.0
22½	1552	4.7	22½	8379	43.9
25	1645	5.2	25	4758	23.1
30	1793	6.1	30	1890	6.6
33½	1803	6.1	33½	1824	6.2
35½	1733	5.7	35½	1906	6.7
40½	1706	5.6	40½	3208	14.2
43	1738	5.7	43	3666	16.8
45½	1662	5.3	45½	3785	17.5
48	1632	5.1	48	3983	18.6
50½	1686	5.4	50½	4402	21.0
53	1645	5.2	53	3558	16.2
55½	1896	6.1	55½	2698	11.3
58½	2356	9.3	58½	2586	10.6

Average Standard Count Before
12044

Average Standard Count After
12176

EXPERIMENT II

Air Dry (Control)			Air Dry (Sample)		
Depth (inches)	Probe Reading	% Moisture by Volume	Depth (inches)	Probe Reading	% Moisture by Volume
0	70	.1	0	73	.1
8	120	↓	8	469	.1
12	170		11	1215	2.7
16	218		12	1350	3.5
20	223		13	1385	3.7
24	211		14	1318	3.3
28	231		15	1165	2.4
32	226		16	1001	1.5
36	215		17	788	.3
40	231		18	642	.1
44	224		19	517	↓
48	228		24	353	
52	235		29½	676	
56	209		30½	650	
58	201		31½	674	
		32½	656		
		33½	608		
		34½	529		
		35½	518		
		36½	456		
		37½	390		
		43	323		
		48	462		
		49	452		
		50	433		
		51	421		
		52	399		
		53	402		
		54	368		
		55	327		
		56	289		
		58	257		

Average Standard Count Before
12223

Average Standard Count After
12148

EXPERIMENT II

Saturated (Control)			Saturated (Sample)		
Depth (inches)	Probe Reading	% Moisture by Volume	Depth (inches)	Probe Reading	% Moisture by Volume
0	3209	14.2	0	2907	12.5
8	7951	41.4	8	8039	41.9
12	8004	41.7	11	8909	46.9
16	7902	41.2	12	9153	48.3
20	8167	42.7	13	9135	48.2
24	8307	43.5	14	8981	47.4
28	8322	43.6	15	8826	46.5
32	8130	42.5	16	8644	45.4
36	7916	41.2	17	8386	43.9
40	8118	42.4	18	8214	43.0
44	8099	42.3	19	8131	42.5
48	8111	42.4	24	1842	42.5
52	8077	42.2	29½	8189	42.8
56	8042	42.0	30½	8247	43.1
58	8001	41.7	31½	8080	42.2
			32½	8066	42.1
			33½	8082	42.2
			34½	8110	42.4
			35½	7996	41.7
			36½	8042	42.0
			37½	8159	42.6
			43	8004	41.7
			48	8298	43.4
			49	8266	43.2
			50	8221	43.0
			51	8161	42.6
			52	8205	42.9
			53	8081	42.2
			54	8171	42.7
			55	8023	41.9
			56	8217	43.0
			58	8230	43.0

Average Standard Count Before
12151

Average Standard Count After
12166

EXPERIMENT II

Drained 24 hrs. (Control)			Drained 24 hrs. (Sample)		
Depth (inches)	Probe Reading	% Moisture by Volume	Depth (inches)	Probe Reading	% Moisture by Volume
0	261	.1%	0	270	.1%
8	1294	3.2	88	1580	4.8
12	1518	4.5	11	2575	10.6
16	1694	5.5	12	2848	12.1
20	1652	5.2	13	2913	12.5
24	1634	5.1	14	2795	11.8
28	1663	5.3	15	2625	10.8
32	1725	5.7	16	2328	9.1
36	1668	5.3	17	2138	8.0
40	1701	5.5	18	1878	6.5
44	1741	5.8	19	1769	5.9
48	1632	5.1	24	1572	4.8
52	1672	5.4	29½	2001	7.3
56	2059	7.6	30½	2024	7.4
58	2634	10.9	31½	2062	7.6
			32½	2096	7.8
			33½	1906	6.7
			34½	1900	6.7
			35½	1866	6.5
			36½	1812	6.2
			37½	1696	5.5
			43	1698	5.5
			48	1730	5.7
			49	1767	5.9
			50	1840	6.3
			51	1817	6.2
			52	1802	6.1
			53	1763	5.9
			54	1803	6.1
			55	1862	6.5
			56	1831	6.3
			58	2051	7.5

Average Standard Count Before
12047

Average Standard Count After
12147

INTERMOUNTAIN FOREST & RANGE EXPERIMENT STATION
FORESTRY SCIENCES LABORATORY
860 NORTH 12th EAST
LOGAN, UTAH 84321

9 JUN 1975

VITA

Terry Lee Andreessen

Candidate for the Degree of
Master of Science

Thesis: The influence of roots on the accuracy of soil-moisture measurements taken with the Troxler Neutron probe.

Major Field: Watershed Science

Biographical Information:

Personal Data: Born at Waterloo, Iowa, June 11, 1945, son of Roy A. and Emma L. Andreessen; married Carole Jean Ernest August 13, 1966; one daughter Angela Jean Andreessen, born May 2, 1968.

Education: Attended elementary school in Evansdale, Iowa; graduated from Orange Twp. High School in 1963; attended Mason City Junior College for one year; attended Iowa State University for one quarter; received the Bachelor of Science Degree from Utah State University in Forest Watershed Management in 1968, and Master of Science in 1975.

Professional Experience; Summer of 1967, forestry aid with U. S. Forest Service; June of 1968; employed as a Watershed Scientist, U. S. Forest Service; August 1968, drafted into armed forces; June 1970 to October 1971, Graduate Research Assistant, Utah State University; November 1971 to present, Forest Hydrologist, Salmon National Forest, U. S. Forest Service.