

Design and Development of a 3U CubeSat ADCS Testing Assembly with Matching Inertia Tensor



UNIVERSITY
of HAWAI'I
MĀNOA

Yosef Ben Gershom^{1,2}, Brielyn Onodera¹, Marshall Rayno¹, Jonah Ang¹

Advisor: A Zachary Trimble, Ph.D.¹

Mentor: Miguel A. Nunes, Ph.D.²

¹ Department of Mechanical Engineering - University of Hawai'i at Mānoa, Honolulu, HI

² Hawai'i Space Flight Laboratory - University of Hawai'i at Mānoa, Honolulu, HI



INTRODUCTION

The Hawai'i Space Flight Laboratory (HSFL), at the University of Hawai'i at Mānoa, has a state-of-the-art Attitude Determination and Control System (ADCS) testbed sized for microsattellites ranging from 50 to 100kg. A new attitude-dynamics simulator and testing platform, sized for CubeSats, was required to verify the ADCS of a 3U CubeSat mission under development. Prior developments of CubeSat sized three-axis simulators include a spherical air bearing, support platform, and mass balancing system [1, 2].

MOMENT OF INERTIA

In order to effectively test and verify how the actuators and algorithms of an ADCS will operate in orbit, it is necessary to replicate the rotational dynamics experienced in space. Such an endeavor includes matching the moment of inertia (MoI) of the testing assembly to that of the satellite mission, in addition to replicating the near-frictionless rotation and torque free environment of space.

PROBLEM & OBJECTIVE

Current CubeSat ADCS testing methods do not consider the MoI of a specified mission, and thus do not provide a complete assessment of how an ADCS will operate once in orbit. The goal of this project was to develop a testing assembly capable of replicating the complete rotational dynamics, with a MoI of $\pm 20\%$, of a 3U CubeSat in orbit. This project was motivated by the request to test and verify a CubeADCS unit, sold by CubeSpace, which will be used in a 3U CubeSat under development by HSFL.

ACKNOWLEDGEMENTS



Lewis Moore, Brennan Yamamoto, Lance Yoneshige, Isaac Rodrigues, Keane Hamamura, Cyrus Noveloso, Andrew Nguyen, Grant Takara, Eugen Toma

MASS MODEL & TESTING ASSEMBLY

- The assembly was first designed in SolidWorks to determine the placement of the assembly components, analyze the center of mass (CM) location, and provide an estimate of the MoI values.
- Once the assembly design was complete, the components were purchased or 3D printed, assembled, and mounted to the HSFL ADCS testbed.
- The CM location in the model was validated by balancing the assembly and manipulating the model to match. The MoI of the model was then validated by measuring the pendulum period of oscillation of the assembly, and calculating the MoI using the CM distance from the model.
- The equation used to solve for the MoI, using the measured period of oscillation, is as follows:

$$I = \left(\frac{T}{2\pi}\right)^2 (mgl)$$

- I : Moment of inertia [kg-m²]
- T : Period of oscillation [s]
- m : total mass of the system [kg]
- g : Gravitational acceleration [m/s²]
- l : Distance from the CM to the CR [m]

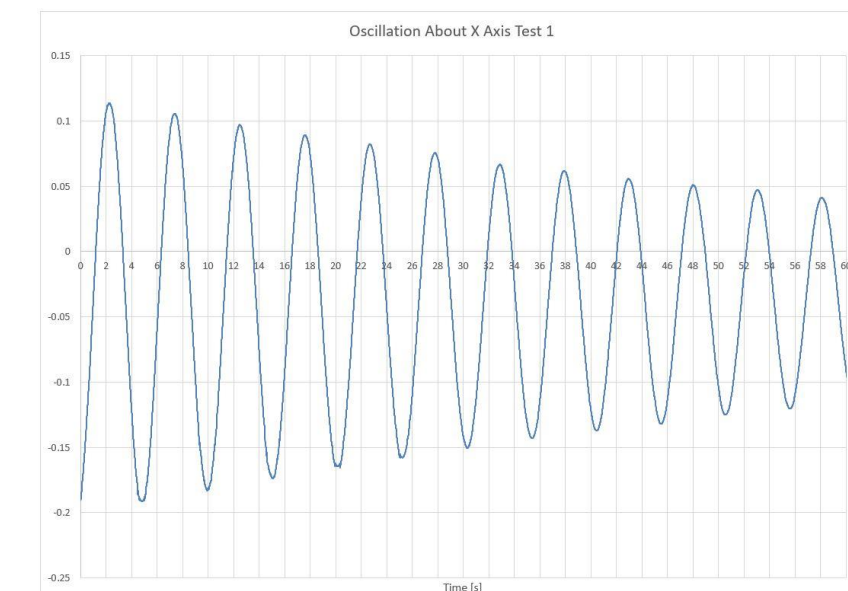

Typical X-Axis Pendulum Test Oscillation Period Result

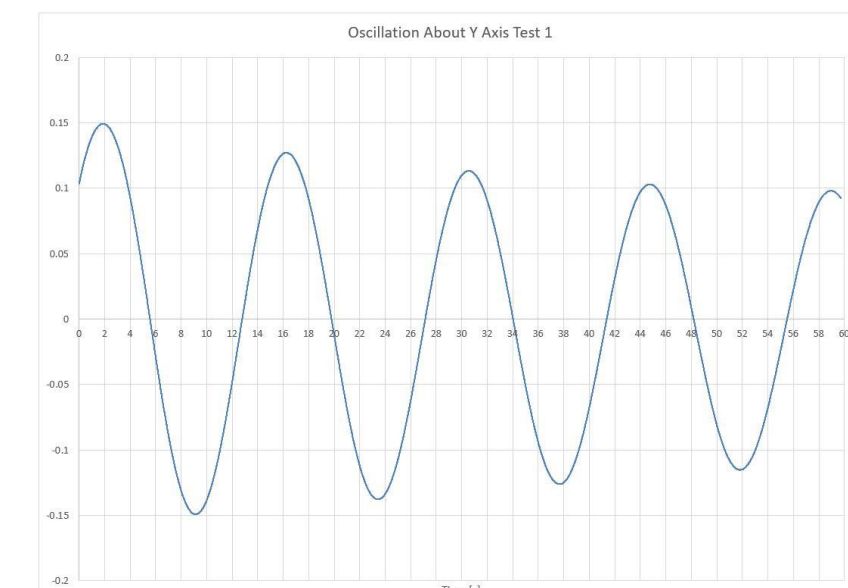

Typical Y-Axis Pendulum Test Oscillation Period Result

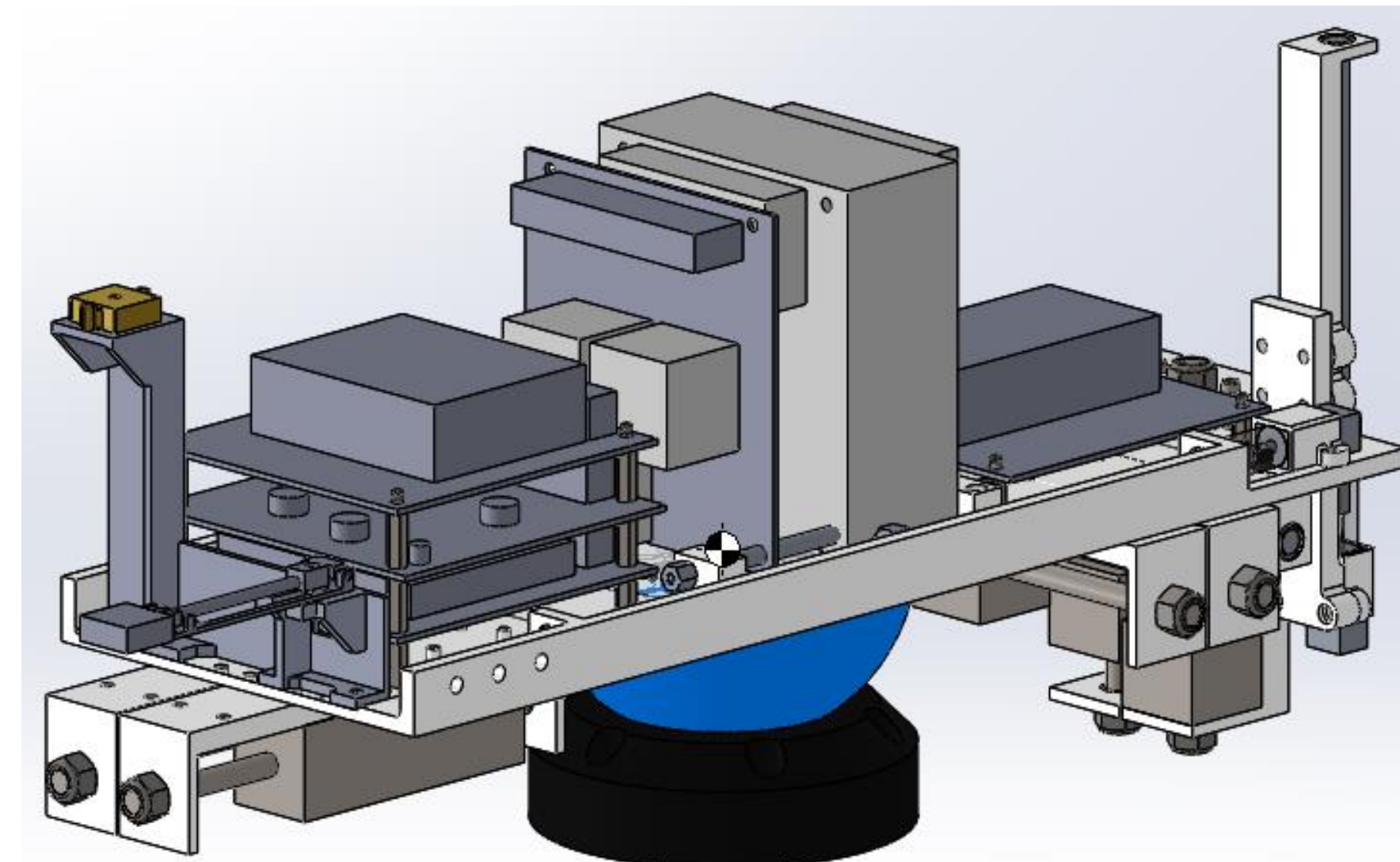

SolidWorks Mass Model Design of Testing Assembly

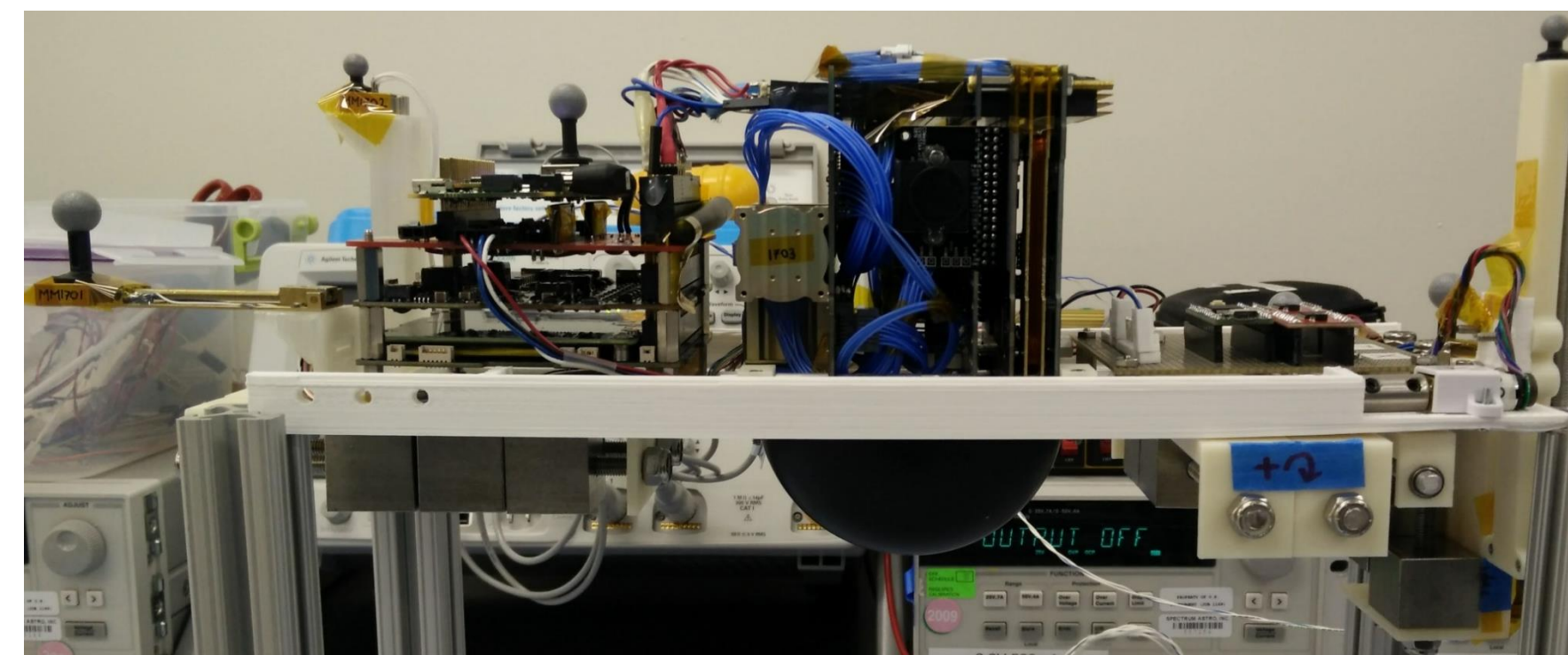

Complete Assembled Testing Assembly

| MoI [g-m ²] | Target | Model | Calculated | Mean | Uncertainty |
|-------------------------|---------------|---------------|--------------------|--------------------|--------------------|
| [Ixx, Iyy, Izz] | [8, 49, 49] | [8, 47, 44] | [8.6, 62.4, n/a] | [8.3, 54.7, n/a] | [±4%, ±14%, n/a] |

THE HSFL ADCS TESTBED

The HSFL ADCS testbed is contained in a 10,000 class cleanroom and capable of conducting complete end-to-end verification of satellite ADCS. The testbed features the following components:

- Air Bearing Platform
- Helmholtz Cage
- Sun Simulator
- GPS Simulator
- Motion Tracking System

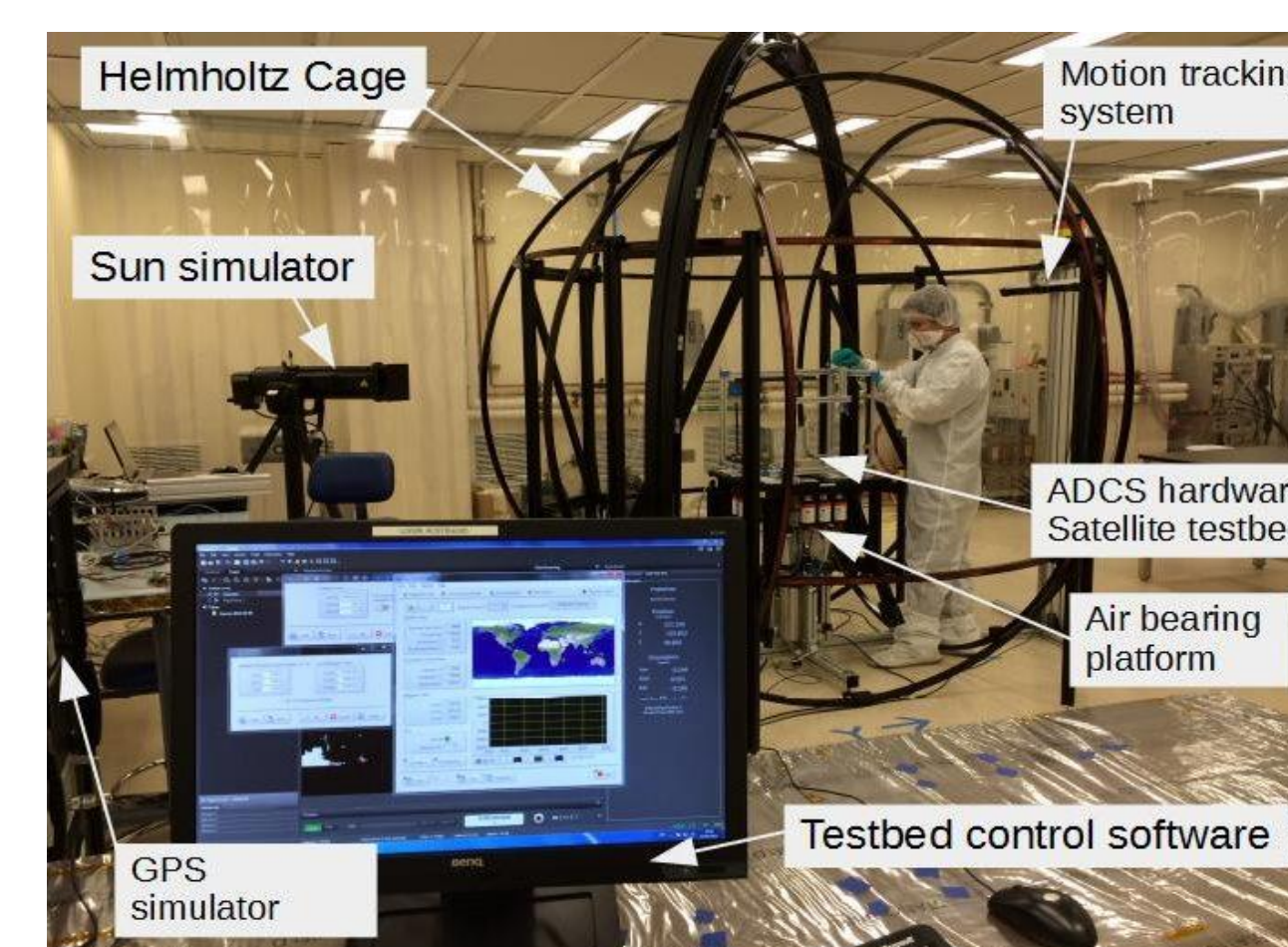

The HSFL ADCS Testbed in the Integration and Testing Cleanroom designed and built by Astro- und Feinwerktechnik Adlershof GmbH (Astrofein)

SPHERICAL AIR BEARING

- Spherical air bearings, due to their near-frictionless nature, are commonly used for spacecraft simulation to replicate frictionless rotation with three degrees of freedom.
- A 100mm diameter spherical air bearing, sold by Physik Instrumente, was chosen for its small size and consequent low MoI addition to the assembly. The air bearing was mounted on a pedestal in the center of the testbed.

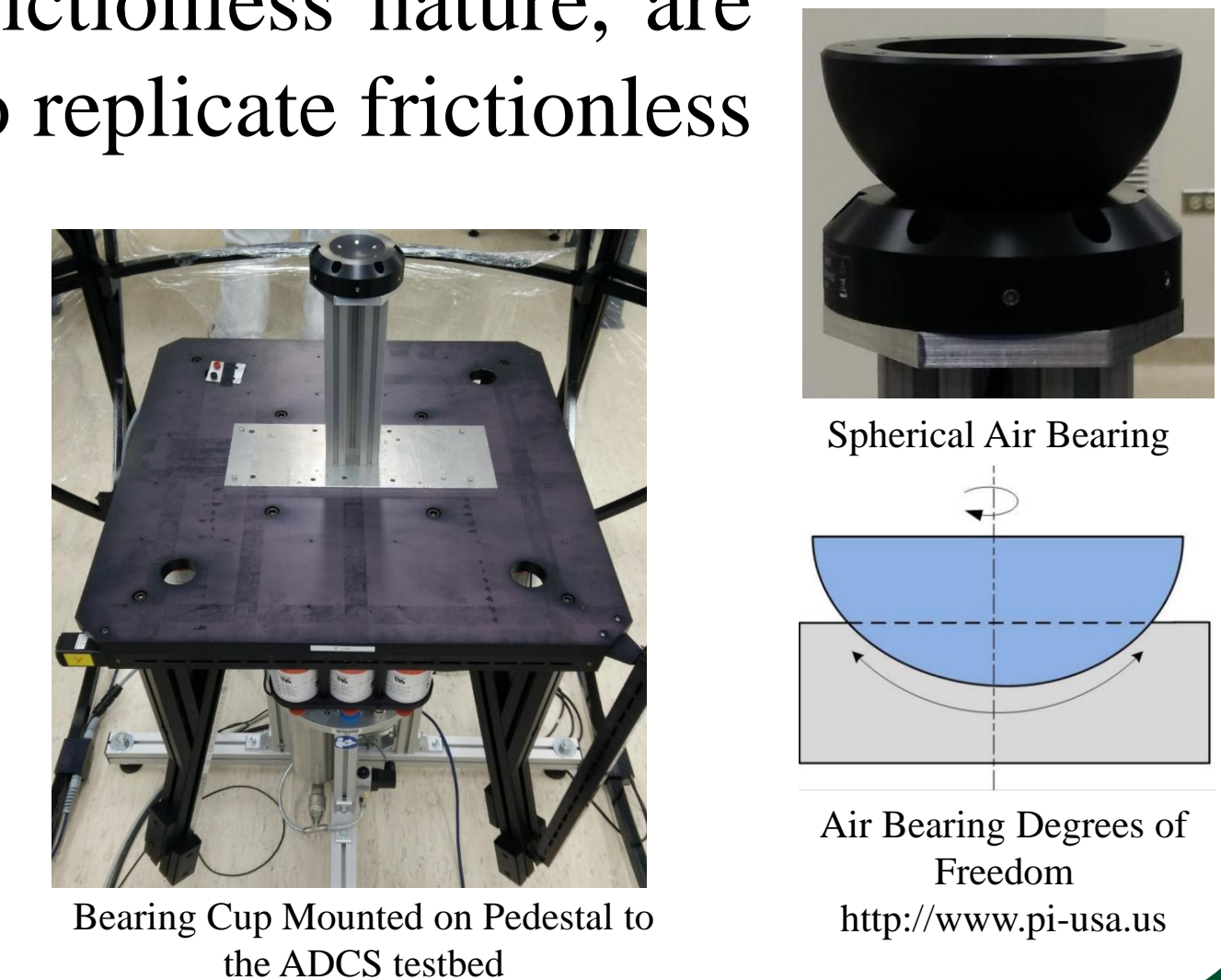

SUPPORT PLATFORM

The support platform was 3D printed in PLA to minimize mass and allow for design versatility for different CubeSat missions. The platform supports all the ADCS components, the mass balancing system, and interfaces with the air bearing hemisphere. The mounting locations of the components were designed such that the MoI of the assembly matched that of the satellite within 20%.

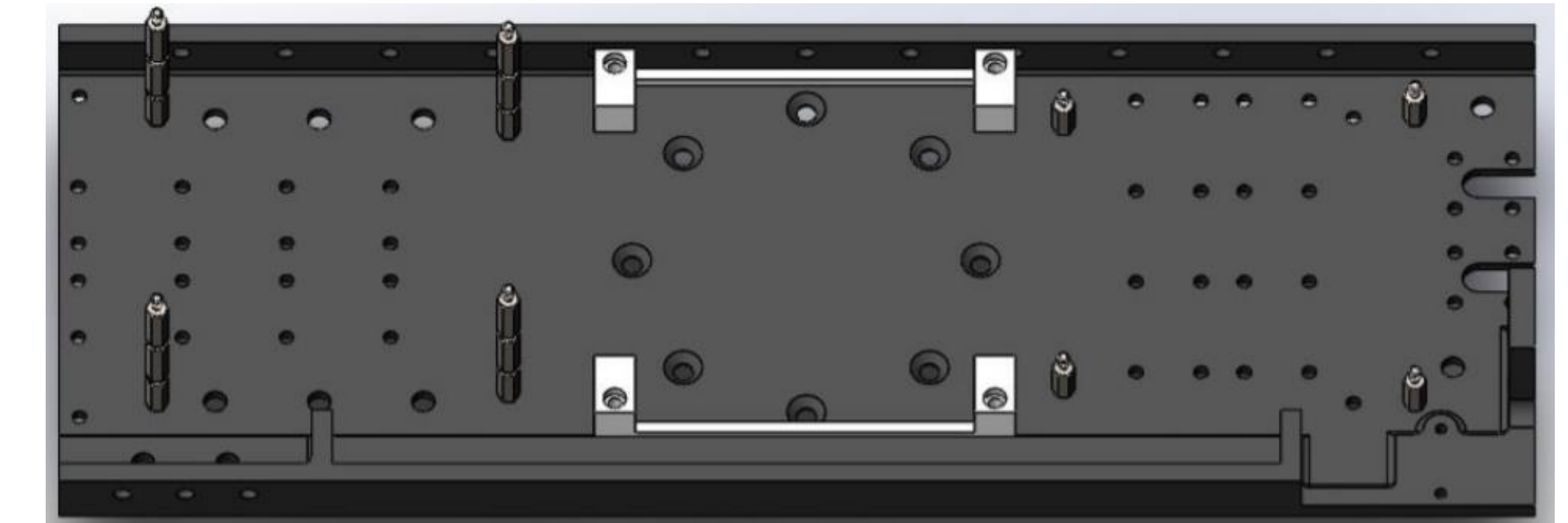

3d Printed Support Platform Model Featuring PC-104 PCB Hole Patterns, ADCS Mounting Bracket, and Hemisphere Interface Hole Pattern

MASS BALANCING SYSTEM

The mass balancing system is used to eliminate gravity torques by co-locating the CM of the assembly with the kinematically defined center of rotation (CR) of the air bearing to within 1μm. The system features manual coarse mass trimming and motorized fine mass trimming, utilizing moveable masses driven by linear actuators along each of the three primary axes.

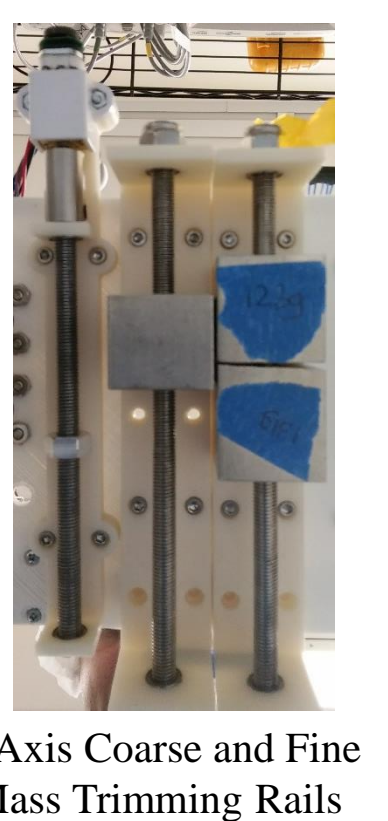

Y-Axis Coarse and Fine Mass Trimming Rails

REFERENCES

- Chesi, S., Perez, O. and Romano, M. (2015) "A Dynamic, Hardware-in-the-Loop, Three-Axis Simulator of Spacecraft Attitude Maneuvering with Nanosatellite Dimensions," *Journal of Small Satellites*, 4(1), pp. 315–328.
- Meissner, D. M. (2009) A Three Degrees of Freedom Test Bed for Nanosatellite and Cubesat Attitude Dynamics, Determination, and Control. Naval Postgraduate School.