

# United States Patent [19]

[11] Patent Number: **6,056,790**

Clark et al.

[45] Date of Patent: **May 2, 2000**

[54] **METHOD FOR AUTOMATED DYEBATH REUSE**

[75] Inventors: **James Leonard Clark**, Snellville;  
**Wayne Coleman Tincher**, Doraville;  
**Wiley Don Holcombe**, Decatur;  
**Richard A. Carey**, Stone Mountain;  
**Elizabeth Wise White**, Atlanta, all of Ga.

[73] Assignee: **Georgia Tech Research Corp.**, Atlanta, Ga.

[21] Appl. No.: **09/085,743**

[22] Filed: **May 27, 1998**

[51] Int. Cl.<sup>7</sup> ..... **D06P 5/00**

[52] U.S. Cl. .... **8/502**; 8/400; 8/440; 8/504;  
8/930; 8/931

[58] Field of Search ..... 8/400, 440, 502,  
8/504, 929, 930, 931

[56] **References Cited**

**U.S. PATENT DOCUMENTS**

- 3,801,276 4/1974 Gray ..... 8/502
- 3,807,872 4/1974 Pronier ..... 356/181

- 3,944,383 3/1976 Davis ..... 8/440
- 4,152,113 5/1979 Walker et al. .... 8/440
- 4,165,288 8/1979 Teed et al. .... 8/440
- 4,350,494 9/1982 Scheidegger et al. .... 8/636
- 4,715,863 12/1987 Navratil et al. .... 8/440
- 5,139,533 8/1992 Hildebrand ..... 8/502

**OTHER PUBLICATIONS**

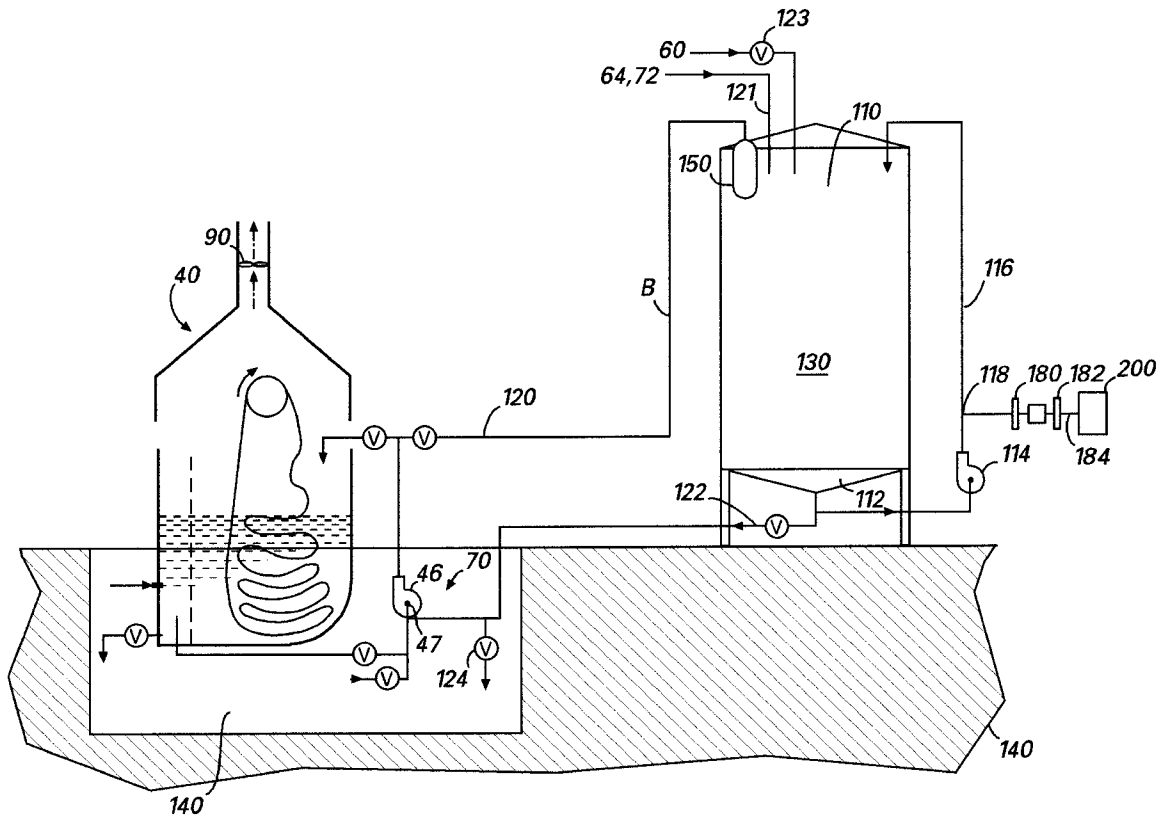
Tincher, "Energy Conservation In Carpet Dyeing By Dye-bath Recycling," Amer Dye Report, pp. 36-44, May 1977.

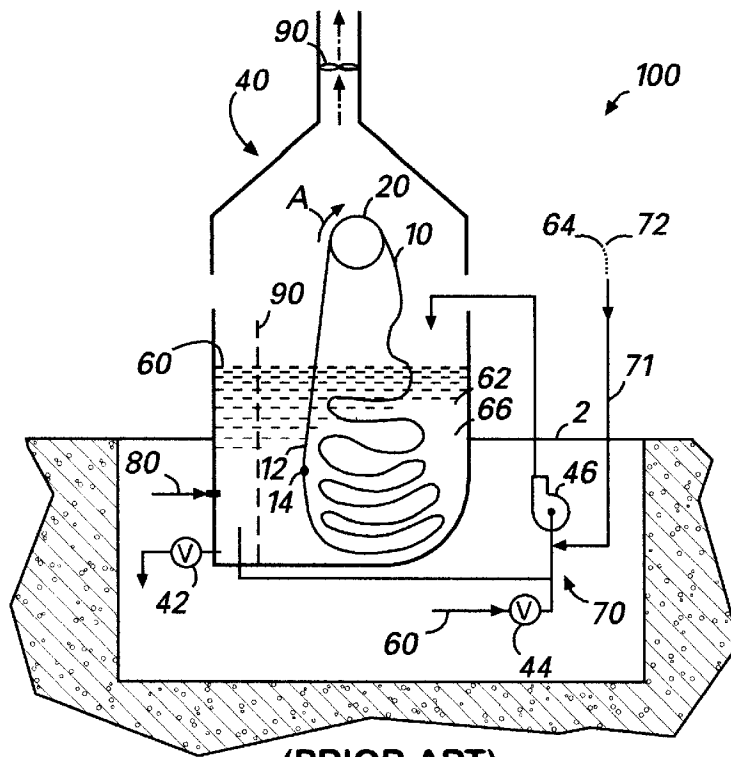
*Primary Examiner*—Caroline D. Liott  
*Attorney, Agent, or Firm*—Deveau & Marquis

[57] **ABSTRACT**

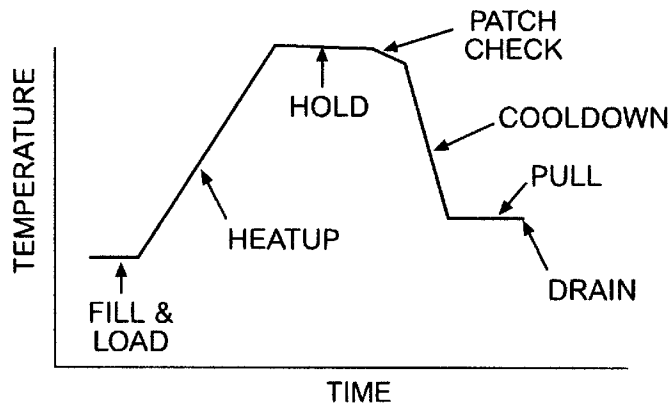
The present invention is a fully automated modified batch dyeing process that provides a process that reduces water consumption, reduces environmental pollution, and reduces the energy and chemical consumption of the conventional batch dyeing process through efficient reuse of spent dye-bath. The invention provides a holding tank which stores the spent dyebath, and an analysis system which allows for the analysis of the dyebath in the holding tank so that the dyebath may be reconstituted and used in the batch dyeing process.

**15 Claims, 4 Drawing Sheets**

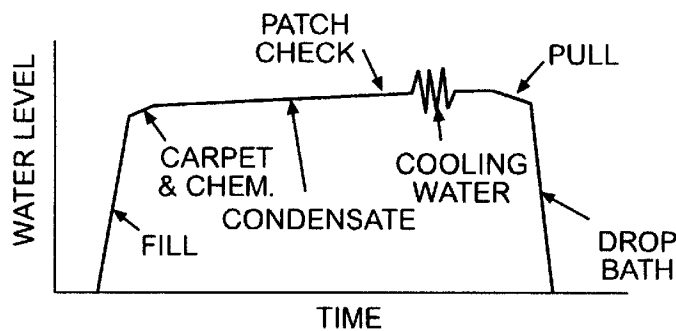




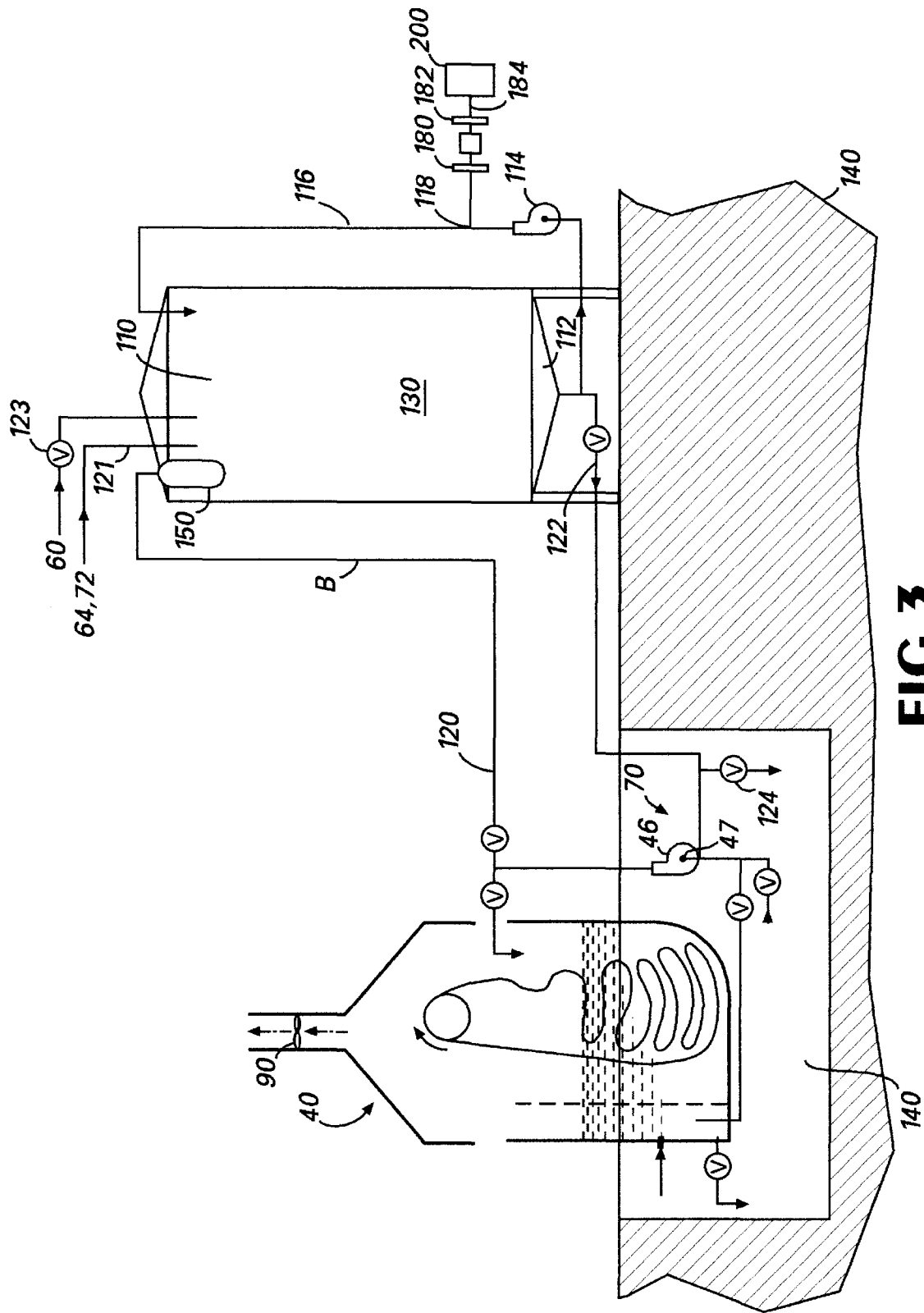
(PRIOR ART)  
**FIG. 1**

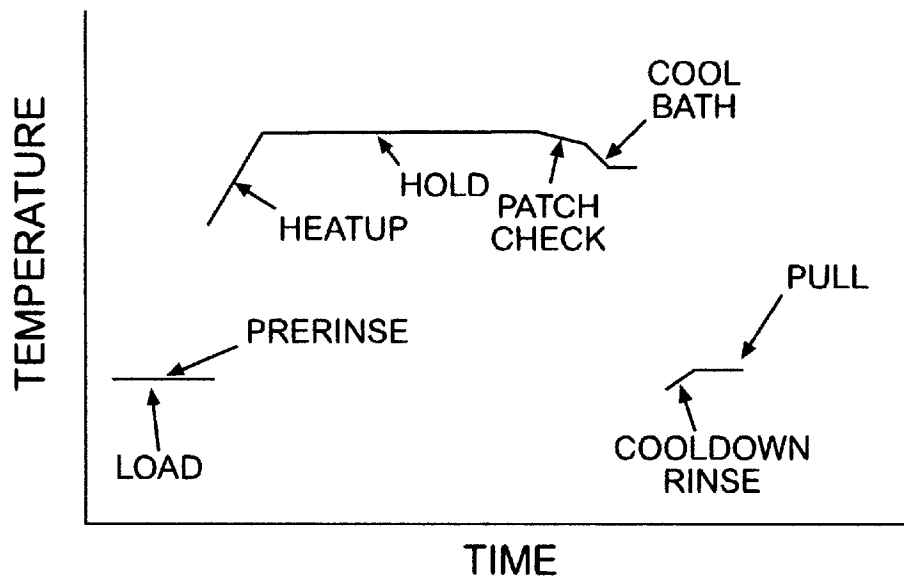


**FIG. 2(a)**

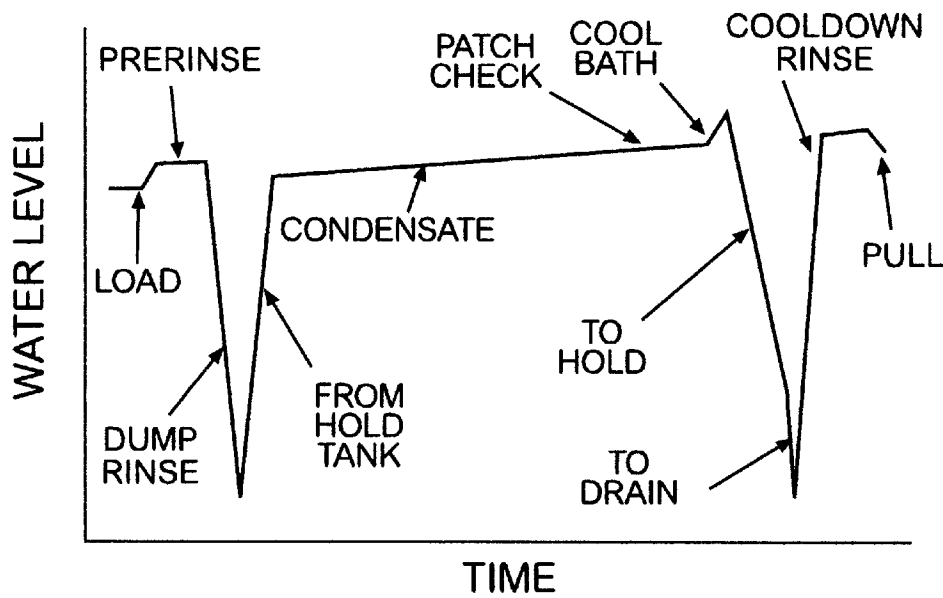


**FIG. 2(b)**

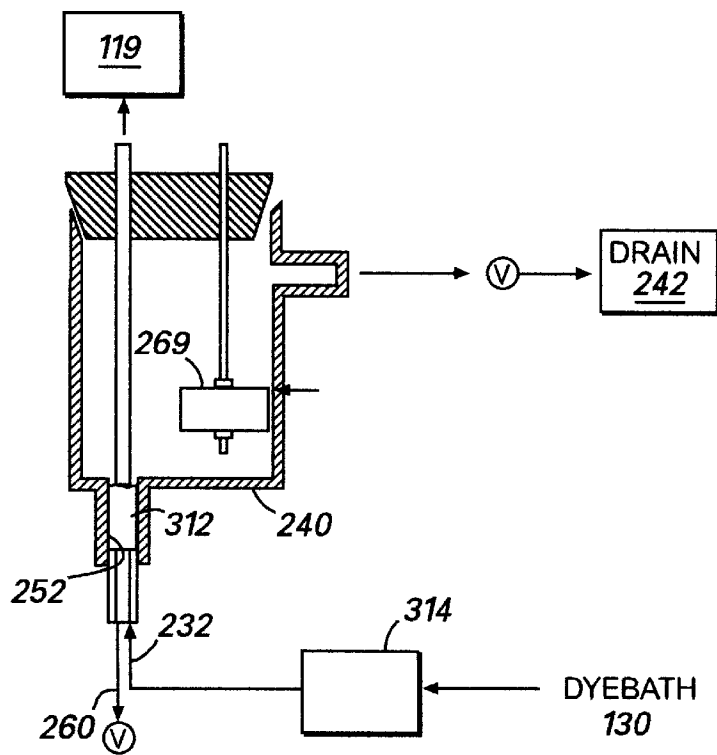
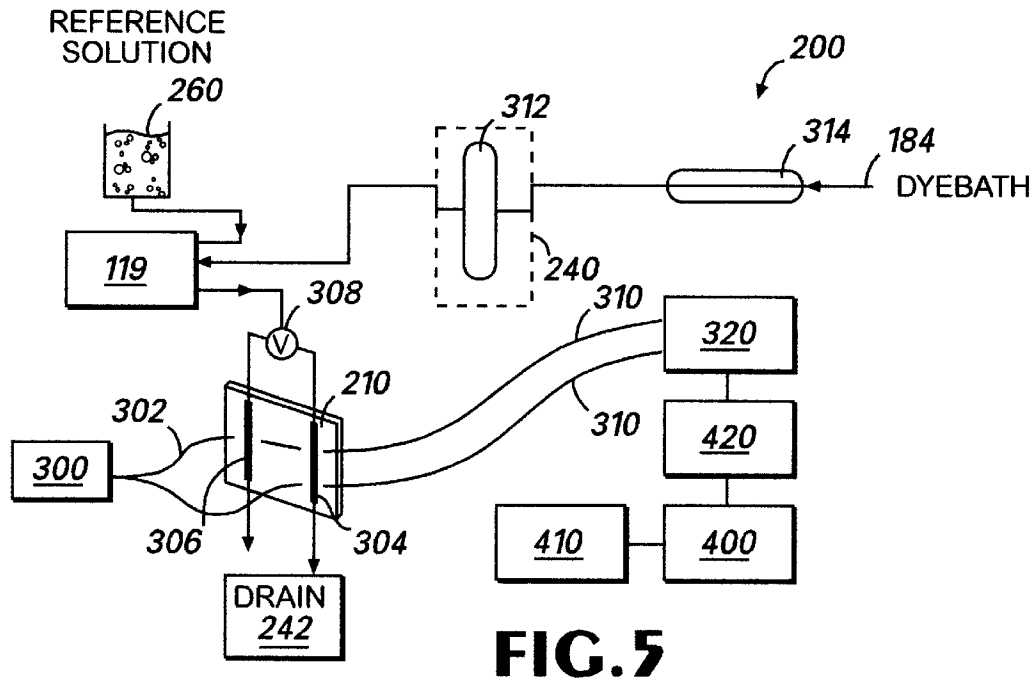




**FIG.4(a)**



**FIG.4(b)**



## METHOD FOR AUTOMATED DYEBATH REUSE

### BACKGROUND OF THE INVENTION

#### 1. Field of The Invention

The present invention relates generally to a textile dyeing method and apparatus. In particular, the invention relates to a modified dyeing method and apparatus comprising an automated analysis system. The modified dyeing process reuses the conventionally wasted dyebaths.

#### 2. Description of Prior Art

The textile industry is a major consumer of water. Approximately 160 pounds of water are required to produce one pound of textile product. Most of the 100 billion gallons of water used by the textile industry each year are consumed primarily in the dyeing and finishing processes for the textiles, namely yarn, fabric and carpet. The vast majority of this water is discharged to the sewer. The waste water, or dyebath, includes dissolved and suspended organic and inorganic chemicals, and, thus, the conventional dyeing process places a significant demand on water resources as well as waste treatment facilities, especially in areas such as Dalton, Ga., where carpet manufacturing plants are highly concentrated.

In a batch dyeing process, one piece (or several pieces) of the textile product is dyed in a vessel containing the dyebath. The bath is agitated or stirred and/or the textile product is tumbled in the bath so that the single dyebath has repeated contact with each portion of the textile product. The vessel may be pressurized, and heat is added to the bath to provide the desired temperature/pressure/time cycle for the dyeing. The piece of textile is then rinsed and removed from the vessel so that another batch may be dyed, and the depleted dyebath is discarded. The textile material is then dried and/or processed further on other production equipment.

In a continuous dyeing process, a piece of textile product is passed lengthwise through one or more pieces of machinery constituting a dye line or dye range. Subsequent pieces of product are sewn together to form a continuous chain of material proceeding through the dye range. The textile material may be exposed to multiple baths (typically of higher concentration than in batch dyebaths), rinses, and drying stages along its path, but it encounters each stage in succession and for a limited time in each.

Typically, continuous dye processes provide economies of scale and are attractive for larger production lot sizes in a particular color, whereas batch dye processes provide manufacturing flexibility and economic benefits in the case of small lot sizes. Certain products are also more amenable to either continuous or batch dyeing processes.

The nature of the batch dyeing process for textiles is especially wasteful. In the conventional batch dyeing processes, the dyebath is used only once per dye cycle, then discharged to the sewer. In addition, the valuable auxiliary chemicals mixed in the dyebath are lost with each discharged batch of water, which themselves place significant loads on the waste treatment system.

Both continuous and batch dyeing processes are common for broadloom carpets. Continuous dyeing offers cost advantages and greater ease in obtaining uniform color over a large production lot size. In contrast, batch dyeing is now used predominately for heavy-weight, high-end carpets which cannot be dyed as well with a continuous processes. Batch processes also offer the advantage of production flexibility due to the small lot size.

The conventional batch dyeing of nylon broadloom carpets is typically performed in an atmospheric vessel, or beck. Water, auxiliary chemicals, dyes and the carpet are loaded in the beck, with the carpet sewn in a loop so that it continuously enters and exits the dyebath, providing agitation and bath-to-carpet contact. The bath is slowly heated and then held at a specified, critical dyeing temperature for a given amount of time. Both the temperature and hold time are product dependent. As the bath is heated, the dyes penetrate the fiber of the carpet and form chemical bonds. The elevated bath temperature is held for a sufficient period of time to permit the dyes to migrate to a uniform distribution over the carpet, producing a level dyeing. A patch check on the carpet is then performed, and if the carpet is properly shaded, the bath and carpet are then diluted with fresh water to bring the carpet to a temperature acceptable for handling. The carpet is then removed, and the bath including virtually all of the auxiliary chemicals and any residual dyes is drained to the sewer. Several disadvantages of this conventional process are that it consumes excessive water, wastes the stored thermal energy in the dyebath, and releases dyes and auxiliary chemicals to the waste stream.

The dye used in the batch dyeing process is typically a mixture of three components—yellow, red and blue—with a ratio and total quantity selected to give the designed color for the textile product. The auxiliary chemicals used in the batch dyeing process typically include wetting agents, pH control agents, leveling agents, chelating agents, and others which aid the dyeing process, but are not consumed during the dyeing process like the dyes are consumed.

Generally, by the time the finished color of the carpet is achieved in the conventional batch dyeing process, the dyebath has undergone several changes. The dyebath temperature is about 200° F., in contrast to the initial starting, ambient temperature of about 60° F. There has been a small amount of dilution to the dyebath due to condensate of the injected steam, the preferred mode of heating. Most but not all of the dye has been transferred from the bath to the carpet fiber, but the auxiliary chemicals are essentially unchanged, and remain in the bath.

This spent dyebath, destined for the sewer in the conventional process, represents a significant investment of energy and chemicals which are available for reuse. Dyebath reuse offers the opportunity to reduce the consumption of water resources, to reduce energy consumption in the dyehouse, to conserve/reuse expensive auxiliary chemicals, and to reduce environmental pollution. There is also the potential for production rate increases due to reduced heatup times required by the present invention.

Presently, only for certain combinations of dyes and fibers, there is the possibility to reuse spent dyebaths in subsequent dyeings. However, for these combinations the amount of residual dye left in the baths is generally sufficient to result in off-shade dyeings of subsequent batches. Therefore, for these combinations, the concentration of residual dye for each of the component dyes must be accurately determined, and the recipe for the next dyeing be adjusted accordingly.

Dyebath reuse with manual intervention has been demonstrated on a limited scale for a wide variety of textile products. Yet the barrier to industry-wide implementation is the human involvement required to implement dyebath reuse. A trained chemist is necessary to collect test samples at the end of every dye cycle. The samples must then be transported to an equipped laboratory and analyzed for dye concentrations, and the corrected recipe calculated. It simply

is not practical to have personnel on hand round-the-clock to perform these analyses since it can be difficult to find trained chemists willing to work on all shifts, and the employment costs are prohibitive. Further, the human involvement may also lead to analysis and/or calculation errors. Therefore, a solution to this problem is to automate the dyebath analysis process, which the present invention provides.

Various methods and apparatus are known in the textile industry that attempt to relieve some of the disadvantages of the conventional batch dyeing process. For example, U.S. Pat. No. 3,807,872 to Pronier, entitled "Process For Regulating The Concentration Of A Bath Of Dye Or Coloring And Equipment For Implementing This Process" discloses a method and apparatus to control concentration of a dye in a dyebath linearly over time. As disclosed, the first step is the preparation of the dyebath using all the additives except the dye substances. Then a certain volume of the dyebath is taken to act as a pure reference sample. Selected coloring agents are then added to the dyebath and in this way an initial real bath is obtained for dyeing the article. From this real bath, a certain volume is drawn off to form an initial mixed sample. A theoretical consumption curve is simulated by adding steadily and continuously to the initial mixed sample a certain amount of the pure sample. A continuous and steady flow is extracted from the mixed sample and directed to an analysis vessel. Simultaneously, a steady and continuous flow of liquid from the real bath, to which the article to be dyed is added, is directed to a second analysis vessel. Then through analysis, for example, by colorimetry, the liquids passing through the vessels are analyzed. When a difference is detected between the analysis signal corresponding to the mixed sample and real sample, the equilibrium parameters of the real bath are modified in order to cancel out the difference between the two signals.

Specifically, Pronier describes the desire to regulate the rate of change of dye concentration in a bath while the dyeing progresses. It suggests that the rate be regulated by temperature control with regulation efforts which compare the changing color of the dyebath to the changing color of a reference solution. Pronier changes the color of the reference at a linear rate by dilution.

While Pronier describes a desire to make optical measurements on a continuous sampling basis, it describes reasons that this cannot suitably be achieved. Further, the disclosure of Pronier makes clear that the technique does not involve the absolute measurement of the color of the bath. The present invention's automated analysis system has the capabilities to make the measurements which Pronier suggests can not be done; it can accurately measure the color spectrum of the bath and, therefore, can compute the concentration of each of the individual component dyes. Further, the present invention measures spent dyebaths for reuse in a completely different application of dyebath analysis than Pronier provides, and one for which Pronier is not suitable.

U.S. Pat. No. 3,966,406 to Namiki et al., entitled "Process For Jet Dyeing Fibrous Articles Containing Polyester-Type Synthetic Fibers" discloses a hot start jet dyeing process wherein a solution is prepared and heated in a preparation tank which is separate, but attached to, a dyeing tank so as to feed the dyes to the dyeing tank. A dyeing preparation tank is equipped with a heater to heat the dye liquor in the tank. First warm water and the fibrous articles are placed in the dyeing tank. The dyeing tank is then heated to at least 110° C., preferably up to a 130° C. Dyes and other chemicals are dissolved to disperse in water in the dye preparation tank, heated to 100° C. and then put into the dyeing tank

which is maintained preferably at 130° C. while moving the fibrous article to be dyed in the bath at a rate of 80 to 300 meters/min.

Yet Namiki et al. does not disclose a hot-start process that involves reuse of the dyebaths, one process of the present invention, described infra. It also is specifically designed for polyester fibers, which are dyed at much higher temperatures, and under pressure to keep the bath from boiling away, than nylon which the present invention is more suitable to dye. Starting the dyeing process "hot" for polyester does not present the same challenges that are encountered with nylon.

U.S. Pat. No. 4,104,753 to Schuierer, entitled "Processes And Apparatus For The Batch Wet Treatment Of Textile Material" discloses batch dyeing of textile materials wherein during each circuit of textile immersion into a dyebath, the textile material moves from a liquor bath and is freed from the adhering surplus dye liquor to a large extent by a nozzle system feed with compressed air. The textile materials are then shock cooled by a cold water sprinkler prior to discharge from the dyeing tank. In this manner, the dyebath does not need to be cooled before the textile materials are discharged, and the dyebath may be reused in hot form.

Schuierer describes a batch dyeing system which first removes the fabric without cooling the bath, and then subsequently cools the fabric, and does not address the issues of quality defects which might be introduced to the product by these thermal shocks. Unlike Schuierer, in relation to the process of hot-termination of the present invention, described infra, the present invention is not interested in "How do you stop the process hot?" but "How do you get a good product if you do?" This is a challenge in the nylon carpet dyeing process not addressed in Schuierer. Further Schuierer does not disclose reuse of the bath that produces a quality product.

U.S. Pat. No. 4,152,113 to Walker et al., entitled "System For Dyeing Hosiery Goods" discloses a system for batch dyeing hosiery goods where the dyebath is recycled and reused in successive dyeing cycles. The dyebath unabsorbed by the hosiery goods is removed from the dye vat or container and directed to a waste water holding tank. Subsequently, spent rinse and finish waters are transferred from the vat to a waste water holding tank after the various rinse and finish operations. Periodically, the waste fluids are directed to a treatment zone where they are clarified sufficiently for utilization in the bath, rinse and finish operations in subsequent dyeing cycles. A small amount of the dyebath directed from a dye waste tank back to a machine via line for a subsequent dyeing cycle is diverted through a line and analyzed by instrumentation to determine the quantities and colors of the various dyes that must be added to result in a desired dye shade of the hosiery goods.

Walker et al. describes a process to clean up dyeing waste water so that it can later be reused. The Walker et al. process specifically attempts to remove the residual dye from the spent bath during the treatment process. The present invention does not rely on a waste treatment system. Instead, it reuses as much of the water, residual dye, auxiliary chemicals, and energy as possible by adding the necessary makeup chemical and dye quantities to make the bath suitable for the next batch. This approach requires the use of an analysis system to reveal the makeup quantity of dye required, but offers greater reuse benefits and avoids the treatment system capital and operating costs.

U.S. Pat. No. 4,350,494 to Scheidegger et al., entitled "Process For The Dyeing Of Textile Material And Apparatus

For Carrying Out The Process” discloses batch dyeing of carpet materials, as well as reconditioning and reuse of the exhausted dyebath. The process is characterized in that during dyeing the pH value is lowered, by the addition of an inorganic acid, by at least one unit of pH value. A liquid circulating system is provided including pH monitoring means and dosing means for automatically adding the necessary make-up chemical agents.

Scheidegger et al describes a process in which pH adjustments are used in an attempt to get all of the dye to be taken up by the product so that there is no residual dye in the spent bath. In the commercial batch processes for nylon carpet of the present invention, there is a small but significant quantity of residual dye in the spent baths. This amount cannot be ignored in a dyebath reuse process without off-shade dyeing in subsequent batches. The present invention operates successfully even if all of the dye happens to be taken up by the product, but also offers the flexibility of being able to deal with the residual dyes that are more typically encountered.

In view of the prior art it can be seen that there is a need for a modified dyeing process incorporating an automated analysis system that reuses the conventionally wasted dyebaths. It is to the provision of such a method and apparatus that the present invention is primarily directed.

#### BRIEF SUMMARY OF THE INVENTION

Briefly described, in a preferred form, the present invention overcomes the above-mentioned disadvantages by providing a modified batch dyeing method and apparatus having an automated dyebath analysis process. The present invention, which applies hot-start and hot-termination to the conventional dyeing process which uses cool-start and cool-termination, modifies the conventional dyeing process to specifically incorporate reuse of the dyebath.

The present invention modifies the conventional batch dyeing process by, in a preferred embodiment, providing a holding tank separate from the conventional beck, and connected to the beck by appropriate plumbing, which can be added to the conventional batch dyeing apparatus. Further, the present invention has an automated analysis system to analyze the dyebath in the holding tank to accurately determine concentration levels of dyes in the dyebath.

At the same time that the present modified dyeing process prerinses a first carpet of several carpets to be dyed in the beck, the holding tank is filled with water, and auxiliary chemicals are added to the water in the holding tank. Then the proper concentration of dyes are mixed in the dyebath in the holding tank. When the prerinse bath of the present process is dumped to the drain, the present invention transfers the dyebath from the holding tank to the beck via plumbing lines. Upon transferring the dyebath to the beck, the holding tank is rinsed, and the rinse is flushed to the beck.

At this time the beck is full of dyebath which includes the proper concentration of dyes and auxiliary chemicals, and the holding tank is empty. The temperature of the first bath is slowly heated while the carpet tumbles in the bath. When the temperature of the dyebath reaches the critical dyeing hold temperature for the type of carpet, the hold temperature of the dyebath is held for a period longer than the conventional process hold time.

Upon a successful patch check of the carpet, a portion of the dyebath is transferred to the holding tank. At this point, the beck is not empty of bath so as to keep the carpet somewhat buoyant, and the holding tank is only partially full. The beck and carpet is then bathed in a cool rinse of

water and the carpet brought to a temperature lower than the critical temperature. A portion of the bath in the beck (including the rinse water) is then transferred to the holding tank. At this point, the holding tank is filled with the proper amount of dyebath to be used in the next cycle, and the remaining bath in the beck is drained to the sewer.

Then a cool water rinse is applied to the carpet in the beck to bring the temperature of the carpet to a safe handling temperature and the rinse water left in the beck. While the first carpet is pulled from the beck, a sample of the dyebath in the holding tank is analyzed, and any required auxiliary chemicals and dyes are added to the dyebath.

A second carpet is then installed in the beck, and prerinsed with the rinse water left in the beck from the first carpet dyeing process. This water is then drained from the beck. Then the heated dyebath in the holding tank, which is at an elevated temperature and composed of the proper concentrations of chemicals and dye, is transferred to the beck and the process is repeated.

The automated analysis of the dye concentrations of present invention is preferably performed by absorbance spectrophotometry. In one embodiment, both a sample of the dyebath in the holding tank, and a sample of a reference solution which consists of water and all of the auxiliary chemicals in the same concentration as in the dyebath, is analyzed by light passing through the two samples in a dual flow cell, where the light is then carried to a dual-beam spectrophotometer which measures the light absorbance for the wavelengths covering the visible spectrum.

Several challenges were overcome in order to make dyebath reuse possible and attractive to the textile industry. Generally, the waste produced by conventional dyeing process challenged the inventors to create a more efficient dyeing process. Reuse of the dyebath was an opportunity to significantly curtail the waste of dyes, auxiliary chemicals, thermal energy, water, and effluent of the conventional batch dyeing process. Yet the process of dyebath reuse presented its own challenges, challenges which are overcome by the present invention.

The first challenge was in the necessary changes to the conventional dyeing process. Conventional dyeing starts cold with gradual heating, and at the end of the cycle, the bath and carpet are cooled by dilution. Yet, for effective capture and reuse of the energy and chemicals, the bath must be recovered hot, without significant dilution, and the subsequent batch must be started hot. Yet if the conventional process were to use hot-start and hot-termination of the dyeing process, it would result in product quality defects, and suitable adjustments would have to be developed and implemented. Therefore, the industry did not attempt this approach.

The second challenge was represented by the small and variable quantity of residual dyes in the spent bath. If these were neglected when a dyebath was reused, subsequent dyeings would be off-shade. It was necessary for the spent bath to be captured, analyzed for the residual quantity of each dye component, and reconstituted to the proper concentration of each dye component as called for in the recipe for the subsequent batch.

In order to be eligible for dyebath reuse, the subsequent batch must use the same auxiliary chemical recipe and the same component dyes as the previous batch, although it may specify a different shade. In most dyehouses, the majority of the products can be dyed with a combination of just three dyes, typically a yellow, a red, and a blue. Some colors may require a different combination, such as a different yellow



dye, or an orange dye instead of yellow. Carpets which use different component dyes in their recipes cannot be dyed in the same reuse sequence because of the dye contamination which would result.

The third challenge was the automation of the present invention. Several industrial scale demonstrations of dyebath reuse were conducted in the 1970's and 1980's, demonstrating the technical feasibility and economic advantages. The process did not achieve commercial acceptance because of the required human involvement. Even though the savings could justify the added labor, plants were not prepared to accept the additional tasks, the additional technical expertise required, nor the risk that human delays or errors in chemical analyses and calculations could adversely impact the production schedule. Thus, commercial acceptance of dyebath reuse required that the process be automated and not impose significant burdens on the production system.

Thus the present invention comprises a modified batch dyeing method and apparatus that removes the quality defects associated with conventional attempts at a hot-start, hot-termination dyeing process, an analysis process to analyze the spent dyebath that will be reused, and provides the necessary automation of the entire process to make the present invention economically attractive to the textile industry.

Three steps are introduced to the conventional batch dyeing process by the present invention to overcome the various problems associated with the hot-start of the batch dyeing process:

1. The carpet is pre-rinsed in a bath containing a leveling agent so that the entire carpet is "treated" with the leveling agent before it comes in contact with the dye. This additional pre-rinse step is introduced before the dyeing process begins to remove finishes and tints which are added to the fibers during the carpet's initial processing.

2. The dyebath is prepared in a separate vessel from where the dyeing is performed so that the dyes can be fully diluted in the bath prior to contact with the carpet. The conventional process adds the dyes directly to the bath in the process vessel which may lead to the problem of spot dyeing.

3. The hold time at the maximum normal process dyeing temperature (critical dyeing temperature) is extended to permit migration of the dye from point to point on the carpet to achieve levelness of dyeing. The additional process time added is balanced by the reduction in the time needed to heat the bath since the bath is hot at the beginning of each reuse batch.

Process quality defects associated with the hot-termination of dyeing are also avoided in the present invention. Upon the expiration of the conventional process hold time, and before the final cool rinse of the carpet, the present invention slightly cools the bath below a certain, critical cooling temperature that is only a few degrees below the normal process dyeing temperature. When the bath temperature is lower than the critical cooling temperature, it is transferred to the holding tank for reuse, and a further cool rinse bath may be introduced into the beck to cool the carpet for safe handling. It has been found that when the bath and carpet are slowly cooled below the critical temperature before transferring the bath to the holding tank, the quality defects of the conventional process do not occur when coupled with hot-termination.

The present invention further incorporates an automated analysis system to continuously analyze the spent dyebath to determine the concentration of each component of the

residual dyes. The automated analysis system provides the analysis so the bath may be reconstituted to the proper dye concentrations for the next dyeing batch. By automating the analysis process, the adverse human factors previously addressed are eliminated. The automated analysis system is preferably interfaced with the plants existing process control system and incorporates all of the required chemistry expertise in analysis system's hardware and software.

The analysis technique for the automated analysis of the spent dyebath is preferably absorbance spectrophotometry. Preferably, a dual flow cell permits a single light source to illuminate both a sample of the dyebath and a sample of a reference solution which consists of water and all of the auxiliary chemicals in the same concentration as in the dyebath (everything except the dyes). The light passing through the two samples is captured by optical fibers and carried to a dual-beam spectrophotometer which measures the light absorbance for the wavelengths covering the visible spectrum. The absorbance spectrum for the reference sample is subtracted from the spectrum for the dyebath sample, providing the absorbance spectrum of just the residual dyes.

Objectives of the present invention include reduced water consumption, reduced environmental pollution, and energy and chemical conservation through efficient reuse of the dyebaths. The present invention incorporates these objectives which leads to an economically-attractive modified batch dyeing process.

Thus it can be seen that there is a need for a modified batch dyeing process comprising an automated analysis system that reuses the conventionally wasted dyebaths, and that is capable of a hot-start and hot-termination. It is to the provision of such a method and apparatus that the present invention is primarily directed.

#### BRIEF DESCRIPTION OF THE DRAWINGS

FIG. 1 is a diagram of the conventional batch dyeing process. (Prior art).

FIG. 2a is a temperature vs. time profile for the conventional dyeing process.

FIG. 2b is a water level vs. time profile for the conventional dyeing process.

FIG. 3 is a schematic of one embodiment of the present invention used in conjunction with the prior art batch dyeing process.

FIG. 4a is a temperature vs. time profile for a modified dyeing process, according to a preferred embodiment of the present invention.

FIG. 4b is a water level vs. time profile for a modified dyeing process, according to a preferred embodiment of the present invention.

FIG. 5 is a schematic view of the components of an analysis system of the present invention according to one embodiment.

FIG. 6 is a schematic view of a reservoir of an analysis system of the present invention.

#### DETAILED DESCRIPTION OF A PREFERRED EMBODIMENT

Referring now in detail to the drawing figures, wherein like reference numerals represent like parts throughout the several views, the standard production method and apparatus 100 of the batch dyeing of nylon carpet is shown in FIG. 1. Generally, the conventional batch dyeing apparatus 100 comprises a beck 40 which is the vessel in which the batch

dyeing occurs. Typically, the beck **40** is sunk below the floor **2** of a manufacturing plant. At the start of the conventional batch dyeing process, the beck **40** is partially filled with water **60** and the carpet **10** arranged in such a way in the beck **40** so that the carpet **10** is continuously run in and out of the water **60**.

It will be understood by those skilled in the art that references to carpet **10** are merely illustrative of many products that may be subjected to the batch dyeing process.

Auxiliary chemicals **72** and dyes **64** are added to the water **60** via tubing **71**, which when mixed together, produce dyebath **66**. Tubing **71** is generally an extension and component of the circulation loop **70** wherein a pump **46** provides the mixing in the dyebath **66** in the beck **40** to maintain uniformity of temperature and dye **64** distribution in the bath **66**. The bath **66** is then slowly heated to a critical dyeing hold temperature (dependent on the type of carpet **10**), and held at the critical temperature for a specified period of time (also dependent on the type of carpet **10**). During the entire heating and holding process, the carpet **10** is tumbled in the bath **66** providing agitation, and the bath **66** recirculated. Also during the entire process, an exhaust means exhausts the interior gases of the beck **40** to the atmosphere. The exhaust means may comprise exhaust fan **90** located at the top of the beck **40**. Once the carpet **10** is at the proper shade, the carpet **10** and dyebath **66** are cooled by a rinse, and the carpet **10** removed from the beck **40**. The dyebath **66** is then drained from the beck **40**.

In a more detailed description of the conventional batch dyeing process, carpet **10** is generally rolled onto a reel **20** in a conventional beck **40**, and the ends **12**, **14** of the carpet **10** are sewn together around the reel **20**. In this configuration, the carpet **10** is a continuous loop of carpet. Then the beck **40** is filled with water **60**. Alternatively, water **60** may be added to beck **40** simultaneously with the sewing. The carpet **10** is moved in and out of the bath **60** by rotating the reel **20**, as shown by Arrow A, which saturates continuous portions of the carpet **10** with water **60**. The auxiliary chemicals **72** (wetting agents, pH control agents, leveling agents, chelating agents, etc.) are added to the water **60** via the recirculation loop **70** having a recirculating pump **46**. Then dyes **64** are introduced into bath **62** (bath **62** is the combination of water **60** and chemicals **72**) which then produces bath **66**. It should be noted that generally the dyebath proceeds through three distinct phases. In the first phase, the dyebath **60** comprises only water **60**. In the second phase, dyebath **62** comprises water **60** and auxiliary chemicals **72**. In the third phase, dyebath **66** comprises dyebath **62** with the addition of dyes **64**.

The bath **66** is then heated by the direct injection of steam **80** at generally a rate of approximately 2–3° F. per minute. A perforated baffle **90** protects the loop of carpet **10** from the recirculation loop **70** and from coming in direct contact with the injected steam **80**. The bath **66** is heated from the ambient temperature (year-round average of ≈60° F.) to a temperature of approximately 200° to 208° F., depending on the product. As the temperature of the bath **66** is increased, the dyes **64** begin to absorb onto the surface of the carpet **10** and diffuse into the amorphous regions of the fibers of carpet **10**. The bath **66** is then held at a holding temperature for the carpet for approximately thirty to sixty minutes while the carpet **10** is continuously circulated through the bath **66**. This agitation provides sufficient time for dye **64** migration in order to ensure a level dyeing. After the hold time has elapsed, the heating stops, and a small patch of the carpet **10** is tested to see if the carpet **10** is the proper desired shade.

If the carpet **10** is on shade, the carpet **10** is then cooled by dilution with cold water **60**, thus raising the residual

bath's **66** level in the beck **40**. A drain **42**, located at the bottom of the beck **40** is then opened and the bath **66** level is dropped. The drain valve **42** is then closed and a water fill valve **44** in loop **70** is opened until water **60** raises the level of the dyebath **66** in the beck **40**. This cycle is repeated until the temperature of the bath **66** has reached approximately 105° F., then the carpet **10** is removed. The entire bath **66** (assuming some trace of dyes **64** and residual chemicals **72** remain in the cold rinse water **60**) is then discharged to the drain **42**. A typical water level vs. time and temperature vs. time profile for this process is shown in FIGS. **2a** and **2b**. Depending on the product to be dyed in the next load, the beck **40** may or may not be cleaned at this time.

Alternatively, if the patch check shows that the carpet **10** is not on shade, the proper adjustments to the bath **66** are estimated, and then make-up dyes **64** are prepared and added to the bath **66**. The make-up dyes **64** may also be referred to as adds **64**. The bath **66** is then reheated to the hold temperature and held again at the hold temperature but for approximately half as long as before, after which another patch check is conducted. This cycle is repeated until a suitable dyeing is achieved. Then the bath **66** is cooled and the carpet **10** removed in the same manner.

This conventional procedure is simply not compatible with effective collection of the dyebath **66**, since not only the energy in stored heat is lost, but most of the valuable chemicals **72** will have been diluted and lost with the overflow. Further, the dilution cooling step of the process involves a significant quantity of overflow to the sewer. In order to save the thermal energy, residual chemicals **72** and dyes **64**, water **60**, and the spent dyebath **66**, a portion of the bath **66** must be collected while it is undiluted and still hot, and the next dyeing started at an elevated temperature. Yet this procedure leads to several problems.

If dyebath **66** reuse were implemented with the sole objective to maximize recovery of energy and chemicals **72**, then the dyebath **66** would be captured for reuse immediately after the patch check of the carpet **10** is completed. Since the carpet **10** cannot be pulled from the beck **40** while it is hot, it would be necessary to transfer the entire bath **66** to a holding tank and cool the carpet **10** in the beck **40** with a rinse bath **60**. This is called a "hotdrop" or "hot-termination" process. Unfortunately, it can lead to defective carpets.

If the 200° F. dyebath **66** were transferred to a holding tank, the hot carpet **10** would be left folded in the bottom of the beck **40**, with a small fraction of the carpet **10** still looped over the reel **20**. Without the buoyancy provided by the bath **66**, the carpet **10** could not tumble by rotating the reel **20**. As the cold rinse water **60** is added to the beck **40**, the carpet **10** would experience rapid cooling, which itself specifically leads to two kinds of quality problems. One is a localized problem, where cold water **60** gives a thermal shock to a fiber tuft, sometimes giving a defect known as "blooming." More notably, as the folded carpet **10** is cooled by the rinsing water **60**, the yarn passes through a transition temperature, and the fibers are set in their position. This results in permanent creases in the surface fiber, a condition known as a "pile deformation" problem.

Neither blooming nor pile deformation problems can be corrected after they occur, so the carpet **10** cannot be sold as a first-quality product. In the conventional dyeing process, these quality problems are avoided by gradually cooling the carpet **10** while keeping it floating in the bath **66** and tumbling over the reel **20**.

Recovering the dyebath **60** hot would mean that the subsequent cycle would start at an elevated temperature.

While this is desirable from an energy conservation standpoint and even offers a possible production rate improvement, it can lead to additional quality problems. At elevated temperatures, the dyes 64 penetrate the fiber and form their chemical bonds much more readily. As a result, dyes 64 tends to bond to the first portion of the carpet 10 they touch, creating non-uniform coloring or unlevel dyeing. In conventional dyeing, the process starts cold, and the continued agitation of the carpet 10 and circulation of the bath 66 contribute to a level dyeing as the temperature increases.

Because of these product quality problems associated with the constraints imposed by dyebath 66 reuse, the conventional dyeing process is modified by the present invention which is compatible with reuse of the baths 66.

The present invention modifies the apparatus of the conventional batch dyeing process by providing a holding means 110 to hold the hot, spent dyebath 66 once in beck 40, and a transfer means 120 to transfer the spent dyebath 66 from the beck 40 to the holding means 110, and transfer means 122 to transfer reconstituted dyebath 130 from the holding means 110 to the beck 40. Further, the present invention preferably comprises an analysis system 200 which analyzes bath 130 so that bath 130 may be reconstituted with dyes 64 and auxiliary chemicals 72 while the bath 130 remains in the holding means 110.

It will be understood by those in the art that the holding means 110 may comprise any suitable vessel or the like that can store heated dyebaths 66. Further, the transfer means 120 and 122 may comprise any suitable plumbing and pumping network which can transfer portions of the dyebath 66, dyebath 130 and water 60 to and from the beck 40 and the holding means 110.

In order to capture the maximum amount of chemicals 72 and energy from the spent dyebath 66, a significant portion of the bath 66 must be recovered before the dilution cooling occurs. The present invention transfers the bath 66 out from the beck 40 and preferably to a holding tank 110 as shown in FIG. 3. Dyebath in the holding tank 110 is referred to as dyebath 130. To avoid the present quality defects associated with hot-termination, after cooling water 60 is added to the beck 40 to reduce the temperature of the carpet 10 and remaining bath 66 below the critical temperature that is only a few degrees below the normal process temperature, a portion of the dyebath 66 is transferred to the holding tank 110 to provide an adequate quantity for the subsequent batch.

In one embodiment of the present invention, the holding tank 110 is a cylindrical tank 12 feet tall and 8.5 feet in diameter, and has a shallow conical bottom 112. Tubing 120 is added to the conventional beck 40 plumbing 70 so that a typical 800 gpm circulating pump 46 on the beck 40 can also be used to transfer the bath 66 to the holding tank 110 along a path indicated by Arrow B. The holding tank 110 is also equipped with a 100 gpm recirculating pump 114 which serves several purposes. A pump discharge line 116 provides for a convenient point 118 to pull off samples of spent dyebath 130 to be sent to the analysis system 200 for testing. After any makeup auxiliary chemicals 72 and dyes 64 are added to the holding tank 110, the recirculating pump 114 also provides mixing of the bath 130 in the holding tank 110. It should be noted that reference to the following specific components are for illustration only, and refer to a retrofit embodiment of a dyeing process provided the inventors at a manufacturing plant.

During the modified process of the present invention, chemicals 72 and dyes 64 are added to the bath 130 in the

holding tank 110 via tubing 121, and not the beck 40, so that the bath 130 will be fully mixed before it comes in contact with the carpet 10 in beck 40. This modification helps prevent the levelness problems. A drain line 122 of the holding tank 110 is connected to the suction side 47 of the recirculating pump 46 on the beck 40. The drain line 122 comprises a valve 124 which permits the holding tank 110 to be drained to a trench 140 when necessary. A water level vs. time and temperature vs. time profile for a preferred embodiment of the present invention is shown in FIGS. 4(a), 4(b).

Preferably, a vortex breaker (not shown) is located in the bottom 112 of the holding tank 110. The holding tank 110 was originally designed as simply a storage tank, and was not intended for the high discharge rates required for the modified process. When it was used with a high transfer rate, a vortex formed inside the tank 110 and air was sucked into the discharge line 122. This inhibited the full transfer of the bath 130 from the holding tank 110 to the beck 40. This problem was resolved by installing a vortex breaker in the bottom 112 of the holding tank 110.

During early trials of the present invention, it was also found that lint accumulated in the holding tank 110. This would lead to analysis errors because significant amounts of dye 64 remained in the lint. Further, the lint could clog the drain line 122. In order to prevent lint from accumulating in the holding tank 110, a lint filter 150 was added where the tubing 120 enters at the top of the holding tank 110. The filter 150 preferably comprises a metal strainer with a replaceable fiber bag made of carpet backing.

A water fine 123 may also connect to the top of the holding tank 110. After the bath 130 is transferred back to the beck 40, a small amount of fresh water 60 is added to the holding tank 110 to flush out the remaining dyebath 130 left in the bottom of the tank 110 into the beck 40.

The holding tank 110 may have a sight glass (not shown) so that the level of the bath 130 can easily be seen. Further, an adjustable probe (not shown) may be added in the holding tank 110 so that the amount of dyebath 130 in the tank 110 is known.

The analysis system 200 of the present system used absorbance spectrophotometry to determine the concentration of each of the three component dyes 64 (yellow, red, and blue) in the spent dyebath 130. As shown in FIG. 5, the analysis system 200 used comprises a light source 300, a metering pump 119, a dual flow cell 210, fiber optic cables 310 and a dual beam spectrophotometer 320 that sends data to a personal computer 420 for analysis. The makeup quantity of the auxiliary chemicals 72 is iteratively calculated based on dilution and losses of bath volumes.

In trials of the analysis system 200 of the present invention, the pump 119 was a Constametric 4100 manufactured by Thermo Separation Products. The Constametric has four inlet ports that are capable of pumping precise ratios of up to four solutions at a time, at flow rates of up to 10 ml/min. This allows a reference solution to be drawn from a reservoir 260 through one inlet port, while the spent dyebath 130 from the holding tank 110 is drawn from a sample reservoir 240 through another port. The pump 119 also allows the option of diluting samples with reference solution if the concentrations are too high to be accurately measured using Beer's Law. Theoretically, absorbance is a linear and additive function of concentration of the component dyes (Beer's law). For simplicity, such linearity was used for calibration, although absorbance can be non-linear. Therefore, the concentration of each of the dyes in the bath

may be determined using calibration curves developed for the specific set of dyes. Causes of non-linearity and methods for responding to it in the analysis have been addressed by White et al (1996).

The light source **300** used was a 3,100 K LS-1 tungsten halogen lamp manufactured by Ocean Optics, Inc. The light coming from the light source **300** is split into two beams with a 200-micron Y-cable **302**. Each side of the Y-cable illuminates one side of the flow cell **210**.

The dual flow cell **210** used was manufactured by Thermo Separation Products. The cell **210** has two identical quartz cells **304**, **306** with a path length of 1.0 cm. One side is used for the reference solution samples, and the other side is used for the dyebath samples. A three-way valve **308** controlling the output of the metering pump **119** is turned on so that the reference side of the cell **210** can be filled with the reference solution. This solution remains in the reference side of the flow cell **210** for the entire reuse sequence. At the beginning of each dyebath reuse sequence, a new reference sample is obtained. The three-way valve **308** is switched so that the sample of spent dyebath **130** is pumped through the sample side of the flow cell **210**. A flow rate of 10 ml/min is pumped for three minutes to flush the cell **210** out, then at 2.5 ml/min while the measurements are taken. Light transmitted through the cells **304**, **306** is sent through a set of 62.5 micron cables **310** approximately 400 feet long to the control room and the spectrophotometer **320**.

A flow cell holder (not shown) was used to connect the fiber optic cables **310** to the cell **210**. Since the flow cells **304**, **306** were spaced only ¼-inch apart, conventional connectors on the ends of the cables **310** are too wide to be placed side by side in order to illuminate each side of the flow cell **210**. The connectors had to be removed from the cable **310** ends, and an adapter added to hold the cables **310** firmly in position.

The detector used was a dual beam SD 1000 spectrophotometer **320** manufactured by Ocean Optics, Inc. The recent development of detectors that can measure absorbencies at multiple wavelengths simultaneously has revolutionized the design of spectrophotometers. It is now possible to analyze for multiple components in a dyebath quickly and precisely. These new detectors have made possible the development of on-line dyebath analysis systems which can measure concentrations in real time. Previously, samples had to be measured manually at each wavelength. Also, new low-cost, dual beam spectrophotometers have been developed which can measure absorbance of both the background solution and the dyebath simultaneously. The previous dyebath reuse process required that the dyes be separated from the background using solvent extraction, which is a very time-intensive process. These spectrometers can be directly connected to and controlled by desktop computers, permitting convenient data analysis and interface to the production systems. These advances in technology now allow the dyebath analysis process to be automated and implemented on a commercial scale.

In the operation of this embodiment of the analysis system **200**, samples of the spent dyebath **130** in the holding tank **110** are drawn from the circulation line **116** on the tank **110** by a ½ gpm transfer pump **180** and delivered through a Y-strainer and a backflushable filter **182**, as shown in FIG. 3. A flow rate in this range is desired in order to purge the transfer line **184** quickly and expedite the analysis procedure. Only a few milliliters of the bath **130** are required for the actual analysis. The bulk of the flow is sent to a drain **242** for the few minutes the pump **119** is running in this sample-

and-analyze step, since the plumbing needed to return the flow to the tank **110** is not justified by the few gallons which are lost. A small portion of this flow is diverted for preparation and analysis.

In order for the samples of the spent dyebath **130** to be analyzed properly in this embodiment, the samples should be cooled to ambient temperature and filtered, and flow should be maintained without allowing air bubbles to enter the flow cell **210**. The flow first passes through a heat exchanger **314** that, in one embodiment, comprises concentric tubes **230** (⅛" stainless steel inside ¼" copper) coiled in a helix. The dyebath **130** flows in the inner tube and is surrounded by counterflowing water **60** in the outer tube of the coil. Heat exchanger **314** cools the flow from generally 190° F. to ambient because in this embodiment, calibration of system **200** was at ambient.

The cooled dyebath sample then enters the bottom of the glass reservoir **240**, shown in FIGS. 5 and 6, with a significant portion overflowing the reservoir **240** and thus sent to the drain **242**. The incoming flow **232** surrounds a porous metal filter **312** positioned in a recess **252** in the bottom of the reservoir **240**, and samples for analysis are extracted from the reservoir **240** through the filter **312**. This configuration assures that the analysis examines the most recent flow into the system.

The reservoir **240** and overflow system is provided in case the metering pump **119** was temporarily to draw samples at a greater rate than the incoming flow. The reservoir **240** further comprises a low-level sensor **269** which is monitored by a control system to assure that the metering pump **119** does not draw the bath **130** level in the reservoir **240** low enough to expose the filter **312** and permit air to enter the system. The procedure for drawing a new sample begins by emptying the previous dyebath **130** from the reservoir **240** through a drain valve **260** until a low-level condition in the reservoir **240** is reached. Then the valve **260** is closed, and the transfer pump **180** delivers the new dyebath **130** until the reservoir **240** is filled to overflowing, so the metering pump **119** may draw a fresh sample. Preferably the sample is thoroughly filtered, since any particulate matter in the flow cell **210** at the time of the analysis will scatter light and cause errors in the analysis.

In addition to the sample to be analyzed, the reference solution must be prepared. This solution contains all of the auxiliary chemicals **72** in the dyebath **130**, but does not include the dyes **64**. This solution is needed for the preferred spectrophotometric analysis of the dyebath **130**.

The reference solution is obtained before the very first carpet **10** in the sequence is dyed. After the holding tank **110** is filled with water **60** and the auxiliary chemicals **72** are added, the circulation pump **114** is turned on to mix the bath **130**. A portion is then pulled the same way a dyebath sample was pulled. However, the reference sample is routed to a separate reference solution reservoir **260** rather than through the heat exchanger **314**. After the reference solution is pulled, the dyes **64** are added to the bath **130** of the holding tank **110** and mixed, and the first carpet **10** can thereafter be dyed.

Because the optical properties of the auxiliary chemicals **72** in the dyebath **130** change upon the first heating and cooling cycle, the reference solution must be heated, then cooled in the same manner as the dyebath **66** in a typical dye cycle. Although not shown, a stainless steel reservoir **260** for the reference solution was insulated and equipped with a thermocouple, an electric resistance heater, and a cooling coil through which cooling water **60** is passed and which is

immersed in the reservoir **260**. The electric heater heats the outside of the reservoir **260**, bringing the solution to the proper temperature, and holds the solution at that temperature. After the specified hold period, the heating is stopped and water **60** is circulated through the cooling coil to bring the solution back to room temperature. Then the solution is drawn from a line at the bottom of the reservoir **260** and passes through a porous metal filter and on to the metering pump **119**.

The three-way valve **308** on the discharge line of the metering pump **119** allows the solution being pumped to be routed to either the sample side or the reference side **304**, **306** of the flow cell **210**. All of this sample preparation equipment is preferably located at the holding tank **110**.

Successful implementation of dyebath **130** reuse requires that the system **200** be fully automated, as well as integrated with the plant's existing production system.

Custom developed software may be used to control the operation of the analysis system **200**, including the sampling valves and pumps, the operation of the spectrometer **320**, and the preparation of the reference solution. As shown in FIG. 5, software also allows the analysis system **200** to communicate via File Transfer Protocol (FTP) with the plant's central computing system **400**, such as a Digital Equipment Corporation VAX, and through the use of switch signals with the beck's programmable logic controller (PLC) **410**. The plant's computer system **400** collects data on all of the dyeings as well as calculates formulas for each dyeing. It also notifies the PLC **410** which one of a variety of standard dye cycles should be used for each process. The PLC **410** controls the operation of the beck **40** throughout the dyeing cycle, including control of pumps, valves, drains, water level, and temperature.

Before each dyeing in a reuse sequence is started, the computing system **400** creates a two-character start file. The first character is either a 0, 1 or 2. A "0" indicates that the dyeing is the first in the reuse sequence. A "1" indicates that the dyeing is a reuse dyeing, but not the first or last in the sequence. A "2" indicates that the dyeing is the last in the reuse sequence, and that the dyebath is to be dumped to the drain after the cool-down. The value of this character is determined from data entered manually at a terminal in the beck control room before each dye cycle.

The second character is either 0 or 1. A "0" means that the carpet to be dyed is made of nylon **6**. A "1" means that the carpet is made of nylon **6,6**. This allows the analysis system **200** to determine which set of calibration curves to use for the concentration calculation. The calibration curves are slightly different because different background chemical recipes are used for the different polymers. The carpet **10** type is determined from information already stored in the plant's computer system **400**.

The analysis system **200** reads this start file and relays the information to the PLC **410**. The PLC **410** then controls the actual dyeing process based on the location of the dyeing in the reuse sequence, as determined from the first character of the start file. The PLC software adjusts the steps in the dyeing process for each of the three possible processes.

After the dye cycle is complete and the dyebath **66** has been sent to the holding tank **110**, the analysis system **200** software calculates the concentration of the dyes **64** in the tank **110**. This information is stored in a data file in the desktop computer **420** of the analysis system **200**, and is retrieved by the plant's computer system **400**. System **400** calculates the amount of each dye **64** in the tank **110** based on the volume of bath **130** in the tank **110** (3714 gal.). The

computer **400**, which already has the recipe for the next bath, calculates the amount of makeup dyes **64** needed for the next dyeing. A new formula extension sheet is printed out in the control room that shows the standard recipe, the amount of dye in the holding tank **110**, and the difference, which is the adjusted recipe.

The use of custom developed software for the analysis system **200** and modifications to the plant's PLC **400** software allow for full automation of the present dyebath reuse process. Since the present automated dyebath reuse process requires approximately the same amount of operator attention as the standard dyeing process, dyebath reuse can now be successfully implemented without the problems associated with human involvement.

## EXAMPLES

Dyebath reuse trials were conducted to demonstrate that batch dyebaths could be automatically captured, sampled, analyzed, reconstituted, and successfully reused for dyeing of nylon carpets. The three dyebath reuse trials had progressively increasing levels of automation. These demonstrations were also to establish the ability to improve the energy, environmental, and economic performance of the dyehouse operations through automated dyebath reuse.

### EXAMPLE 1

The first set of trials was on a non-automated dyebath reuse process, and processed only two carpets **10**, both nylon **6, 6** carpets. It was used primarily to check out the components of the system **100**, which had been installed, and to identify modifications which were required. These trials tested the beck **40**/tank **110** combination and the operation of the pumps and valves. Dye concentrations in the spent dyebath **130** were measured with a prototype analysis system **200** under direction of the desktop PC **420**, and the results were used to adjust the makeup recipe. However, the process was not performed in an automated mode, since portions of the hardware and software were not yet ready.

Before these first trials were conducted, the analysis system **200** was calibrated using laboratory prepared dyebath solutions, each having only a single dye component. Calibration solutions were prepared for the yellow, red, and blue dyes over a range of concentrations. Analyzing several different mixed-dye solutions of known composition validated the calibration data.

The first carpet **10**, nylon **6, 6**, in the trial sequence was prerinsed. Simultaneously, the holding tank **110** was filled with water **60**, and the dyes **64** and auxiliary chemicals **72** were sent to the tank **110** and mixed. After the prerinse water **60** was drained, the bath **130** was transferred from the holding tank **110** to the beck **40**, and the carpet **10** was dyed with the standard heat-up and hold procedure. For this trial, the reference solution was mixed manually and added to the reservoir **260** in the analysis system, where it was heated and cooled by instructions manually entered at the PC **420**. Heating and cooling of the reference solution is required because of a change of optical properties during the first heating cycle, and the properties of the reference solution must match those of the auxiliary chemicals **72** in the spent dyebath **130**.

After the patch check, the dyebath **66** was transferred to the holding tank **110** using the hot-drop process which was previously established. Instructions were manually entered at the PC **420** to pull a sample from the holding tank **110** and analyze it for yellow, red, and blue dye concentrations. Based on the reported dye concentrations and the known

volume of dyebath **130** in the holding tank **110**, the total mass of each residual dye in the tank **110** was calculated manually. These quantities were subtracted from the standard recipe for the next carpet **10**, and the adjusted recipe was added to the holding tank **110**.

#### EXAMPLE 2

For the final set of trials, all of the hardware and software modifications had been completed, and the trials were performed in automated mode, including transfers of the bath **66**, **130** between the beck **40** and holding tank **110**, sampling and analysis of the spent dyebath **130**, and calculation of the adjusted recipe for reconstitution of the bath **130**. The analysis system **200** was recalibrated for this trial, and the new calibration data were validated using solutions of known composition.

In this trial of automated dyebath reuse, a series of five carpets **10**, all nylon **6**, **6**, were dyed, with the duration of the trial again limited by availability of suitable carpets **10** in the dyeing queue. The average process start temperature for the reuse dyeings in this series was 139 F. The average energy savings were 2.45 MBTU per batch. The average auxiliary chemical **72** savings per batch were 64.8 pounds.

All of the carpets **10** were first quality with the exception of the last one in the series, which required several adds and subsequently was downgraded and redyed. It was not clear whether the need to redye this carpet **10** was related to normal variability or to some aspect of the analysis **200** and reuse process. There was a substantial quantity of residual blue dye in the bath **130** recovered from the fourth carpet **10** which could have lead to an erroneous analysis. However, such an error would have only shifted the initial dyeing of the fifth carpet **10**, and such errors can usually be corrected by adds, which were not effective with this particular carpet **10**. Thus, it cannot be stated conclusively whether the need for this redye should be attributed to the demonstration technology and system or not.

The process of one embodiment of the present invention is as follows:

- i. Prerinse the first carpet in the sequence Roll carpet onto reel Back carpet into beck Sew carpet and fill beck Turn on circulation pump and reel Let carpet prerinse Dump prerinse bath to the drain
- ii. Prepare first dyebath (done simultaneously with the prerinse) Fill holding tank with water Add defoamer to holding tank Add auxiliary chemicals to holding tank Turn on circulation pump to mix chemicals Draw reference sample from holding tank and prepare for analysis Drop dyes to holding tank Mix bath in the holding tank
- iii. Dye first carpet Transfer bath from the holding tank to the beck and flush residual bath from holding tank Turn on beck recirculation pump and reel Heat bath to the hold temperature Maintain bath at hold temperature for standard time Perform patch checks and adds as necessary
- iv. Transfer bath to holding tank Pump a portion of bath to holding tank Partially fill beck to cool bath and carpet Pump to holding tank until the level in the tank is full Dump residual dyebath to the drain Fill beck to further cool the carpet and aid in pulling
- v. Pull carpet from beck
- vi. Analyze spent dyebath (simultaneously with pulling carpet from beck) Pull sample from holding tank Analyze sample Calculate concentration Calculate makeup auxiliary chemicals and makeup dyes
- vii. Prerinse carpet with cooling water from previous carpet Drop water level in beck Roll carpet onto reel Back carpet

into beck Sew carpet Add leveling agent Turn on circulation pump and reel Let carpet prerinse Dump prerinse bath to the drain

- viii. Prepare dyebath for reuse (simultaneously with vii) Add defoamer to holding tank Prepare makeup chemicals and dyes and add to the holding tank. Turn on holding tank circulation pump and mix bath
- ix. Dye carpet Transfer dyebath from the holding tank to the beck Heat to the hold temperature Maintain bath at the hold temperature for the amount of time in a standard dyeing plus **30** minutes

If the bath is to be reused, the cycle is started again from step #iv. If the bath is not to be reused, a standard cool-down cycle takes place; then the bath is dumped to the drain.

Other embodiments of the present invention include, for example, a single analysis system **200** used for one holding tank **110** serving one test beck **60**. The plant where the demonstrations of the present invention were conducted has sixteen becks **40** in production. In a plant-wide system, appropriate piping could permit becks **40** to alternately use the same holding tanks **110** so that fewer holding tanks **110** would be required than the number of becks **40**. A single analysis system **200** could also serve multiple holding tanks **110**. Further, automated dyebath reuse may be used in other textile processes.

As part of the commercialization effort, several techniques can be employed which may improve the accuracy of absorbance data obtained with the present analysis system **200**. One technique is to replace the existing tungsten halogen light source **300** with a xenon flash lamp, and modify the analysis system **200** software accordingly. The higher light output would improve the performance of the system **200** since low light output, especially in the short wavelength region, is currently a limiting factor in performance of the analysis system **200**.

The present invention can be applied to a wide range of dye, fiber and product combinations, and not just the acid dyeing of nylon carpet. Automated dyebath reuse can be implemented in the batch dyeing of other textile products such as yam and fabrics.

The automated analysis **200** for acid dyes may also be used with other water-soluble dyes such as direct, basic and reactive dyes to support automated dyebath reuse on different types of fibers. For example, reactive dyes are commonly used to dye cotton. During the dyeing process the dyes undergo a chemical change so that even the residual dyes are not in the same state as at the beginning of the cycle. This presents an impediment to dyebath reuse. However, this application is of significant interest, because the conventional reactive dye process consumes large quantities of salt that are released with the dye wastewater stream. This release of salt-laden wastewater is considered the single most serious water pollution problem facing the textile industry. The conventional process may be modified to permit the baths to be reused, retaining the water, energy, dyes, and salt in the process.

Similar automated analysis **200** procedures can be developed for non-soluble dyes such as disperse dyes, used for polyester. Since these dyes are not soluble in water, the preferred analysis system **200** would experience analysis errors due to separation of the dyes from the water in the sample. Corrective measures would include mixing the sample with a solvent in order to place the dye in solution during the spectrophotometric analysis. The metering pump **119** used in the preferred analysis system **200** was designed for high performance liquid chromatography and is capable of mixing precise quantities of liquids. The pump **119** can be

used to add solvent at known concentrations to the samples before they are delivered to the flow cell **210** for analysis.

The automated dyebath analysis system **200** can also be used to monitor dye concentrations continuously throughout the dye cycle. Samples can be drawn directly from the beck **40** for real-time concentration analysis. Continuous monitoring of the dye concentrations can provide a new process control parameter not previously available in batch dyeing. Presently, monitoring time and temperature controls batch dyeings. By improving control of the dyeing process, the number of off-shade dyeings can be reduced or eliminated. This would decrease the amount of adds and redyes, which would save time and money, as well as water, chemicals and energy. Continuous concentration monitoring could also possibly lead to the development of new dyeing strategies, such as introducing the dyes throughout the cycle, rather than all at once. Continuous monitoring of dye concentrations can be applied as a control technique not only to batch dyeing, but to continuous dyeing processes as well.

Further, other embodiments of the present analysis system **200** include the removal of the use of a reference sample, and using a single beam analysis as opposed to a dual beam analysis described herein.

Although the present invention has been described with respect to particular embodiments, it will be apparent to those skilled in the art that modifications to the method of the present invention can be made which are within the scope and spirit of the present invention and its equivalents.

What is claimed is:

**1.** A method of dyeing at least a first and second textile in dyebaths, the second textile dyed subsequent to the first textile, said method of dyeing providing for the reuse of a portion of the dyebath used for dyeing the first textile during the dyeing of the second textile, said method comprising the steps of:

- (a) providing a first and second vessel;
- (b) pre-rinsing the first textile in the first vessel with an initial pre-rinse solution;
- (c) preparing an initial dyebath in the second vessel with which the first textile is to be dyed and then transferring the initial dyebath from the second vessel to the first vessel;
- (d) dyeing the first textile in the first vessel with the initial dyebath;
- (e) analyzing the first textile for proper dyeing;
- (f) transferring to and storing in the second vessel a portion of the initial dyebath, away from the first textile in the first vessel;
- (g) cooling the first textile in the first vessel;
- (h) removing the dyed, first textile from a remaining portion of the initial dyebath not transferred and stored away from the first textile by step (f);
- (i) analyzing the transferred and stored initial dyebath in the second vessel for its concentration of auxiliary chemicals and dyes;
- (j) reconstituting the stored initial dyebath with dyes and auxiliary chemicals providing a second dyebath in the second vessel in preparation of dyeing a second textile with the second dyebath in the first vessel;
- (k) pre-rinsing the second textile with a second pre-rinse solution in the first vessel;

(l) transferring the second dyebath from the second vessel to the first vessel; and

(m) dyeing the second textile in the first vessel with the second dyebath.

**2.** The method according to claim **1**, wherein said step (b) of pre-rinsing the first textile incorporates an initial pre-rinse solution comprised of water and a leveling agent, said initial pre-rinse solution removing finishes and tints from the first textile that were added to the first textile upon the manufacture of the first textile.

**3.** The method according to claim **1** wherein said step (c) of preparing an initial dyebath comprises the sub-steps of:

- (i) providing an amount of water;
- (ii) mixing auxiliary chemicals in the water, said auxiliary chemicals aiding the dyeing process; and
- (iii) mixing dyes in the water.

**4.** The method according to claim **1**, wherein the initial pre-rinse solution of step (b) is transferred away from the first textile before the dyeing step (d).

**5.** The method according to claim **1**, wherein during the step (d) of dyeing the first textile in the initial dyebath, the temperature of the initial dyebath is slowly heated to process dyeing hold temperature of the first textile.

**6.** The method according to claim **1**, wherein the step (g) of cooling the first textile comprises a first cooling step of cooling the first textile with cool water during which the first textile remains buoyant in the portion of the initial dyebath not transferred and stored away from the first textile by step (f), said buoyancy limiting the detrimental effects of blooming and pile deformation of the first textile.

**7.** The method according to claim **3**, wherein the auxiliary chemicals are not consumed during the dyeing process, and wherein the dyes are consumed during the dyeing process.

**8.** The method according to claim **5** wherein when the temperature of the initial dyebath reaches the process dyeing hold temperature, the process dyeing hold temperature is held and the step (d) of dyeing the first textile continues at said temperature to permit migration of the dyes in the initial dyebath providing levelness-of dyeing.

**9.** The method according to claim **6**, wherein after the step (g) of cooling, a portion of the mixture of the cool water and the remaining portion of the initial dyebath not transferred and stored away from the first textile by step (f) is added to the portion of the initial dyebath transferred and stored away from the first textile by step (i).

**10.** The method according to claim **7**, wherein said auxiliary chemicals are selected from the group consisting of wetting agents, pH control agents, leveling agents and chelating agents.

**11.** The method according to claim **8**, wherein the portion of the initial dyebath transferred away from the first textile of step (f) is at approximately the process dyeing hold temperature before it is transferred, and the transferred portion of the initial dyebath is stored in a manner to substantially maintain the thermal energy of the transferred portion of the initial dyebath.

**12.** The method according to claim **6**, wherein the step (g) of cooling the first textile further comprises a second cooling step comprising removing of at least some of the remaining portion of initial dyebath and cool water mixture from the

**21**

first vessel, and then adding cooling rinse water to the first textile in the first vessel to bring the temperature of the first textile to a safe handling temperature.

13. The method according to claim 1, wherein said step (k) of pre-rinsing the second textile incorporate a second pre-rinse solution comprised of water and a leveling agent, said second pre-rinse solution removing finishes and tints from the second textile that were added to the first textile upon the manufacture of the second textile.

**22**

14. The method according to claim 1, wherein steps (e)–(j) are repeated in connection with the second textile.

15. The method according to claim 1 wherein step (1) includes transferring the second dyebath from the second vessel to the first vessel at an elevated temperature above ambient providing a hot start to the dyeing of the second textile in step (m).

\* \* \* \* \*