

SOLAR POWERED ELECTRIC VEHICLE CHARGER

by

Andrew Moradpour
Jessica Bombardier Shaw

Senior Project

ELECTRICAL ENGINEERING DEPARTMENT

California Polytechnic State University: San Luis Obispo

2017

TABLE OF CONTENTS

<i>Section</i>	<i>Page</i>
Acknowledgements.....	3
I. Abstract.....	4
II. Background.....	5
III. Requirements and Specifications.....	6
IV. Design.....	7
V. Integration.....	8
VI. Testing.....	11
VII. Conclusions.....	15
VIII. References.....	16
 <i>Appendices</i>	
A. Senior Project Analysis.....	17
B. Schematic.....	23
C. Time Schedule Allocation.....	24

LIST OF TABLES AND FIGURES

<i>Tables</i>	<i>Page</i>
1. Table I: Engineering Requirements and Specifications.....	6
2. Table II: Time to Charge (Current system).....	14
3. Table III: Time to Charge (Improved system).....	15

<i>Figures</i>	
1. Figure 1: Sources of U.S. Electricity Generation, 2016.....	5
2. Figure 2: Solar Panel Cart.....	7
3. Figure 3: Wiring Diagram of Outback Flexman 80 MPPT Solar Charge Controller.....	8
4. Figure 4: Wire Connector.....	8
5. Figure 5: Circuit Breaker Connection Terminals.....	8
6. Figure 6: Battery Terminals	9
7. Figure 7: Shunt Resistor Terminals	9
8. Figure 8: Back View of the TriMetric Battery Monitor Panel.....	10
9. Figure 9: View of the Disconnect Cables.....	10
10. Figure 10: Inverter Connections.....	10
11. Figure 11: Battery to Ford Focus Connection.....	11
12. Figure 12: Charge Controller to Battery Connection.....	11
13. Figure 13: Battery Monitor to Battery Connection.....	12
14. Figure 14: Complete Solar Powered Electric Vehicle Charger as Shown in the Senior Project Expo.	13
15. Figure 15: Original Estimate Cost.....	18
16. Figure 16: Actual Final Cost of Component Parts.....	19
17. Figure 17: Final Design of the Solar Powered Electric Vehicle Charger.....	23
18. Figure 18: EE 461 Gantt Chart.....	24
19. Figure 19: EE 462 Gantt Chart.....	24

ACKNOWLEDGEMENTS

Andrew Moradpour

I wish to thank my family, friends, and loving girlfriend, who inspire me to be the best person I can be.

Jessica Bombardier Shaw

First off, I would like to thank Dale Dolan for your guidance throughout this entire year, both with this project and in all the power classes. Thank you to my parents and family for all the love and support throughout my college years. Thanks to all the professors in the Electrical Engineering Department for helping me reach graduation. Thank you to Vicky Tarnovetchi for inspiring me to choose Electrical Engineering. I dedicate my work in this project to my grandfather who finally got his engineer in the family.

ABSTRACT

This project will look into how to create an efficiently-operated solar powered electric vehicle charger. The solar panel will harvest energy from the sun that will be stored a battery pack to be readily available to charge an electric vehicle. These stations could be commercialized to be located along a highway, or personalized for a in-house installation.

BACKGROUND

With electric vehicles becoming more affordable every year, investors are starting to see the demand for charging stations rise as well [1]. We wanted to use this fact and the idea that electric vehicle consumers are typically environmentally friendly individuals to create a electric vehicle charger using 100% renewable energy.

As of now, the electric grid in the United States is not nearly as dependent on renewable energy as it is with fossil fuels [2]. This means that electric vehicle owners that charge their electric vehicle on the electric grid could be contributing harmful emissions to the environment. We wanted to reduce this impact as much as a possible by creating an off-the-grid, solar powered electric vehicle charger.

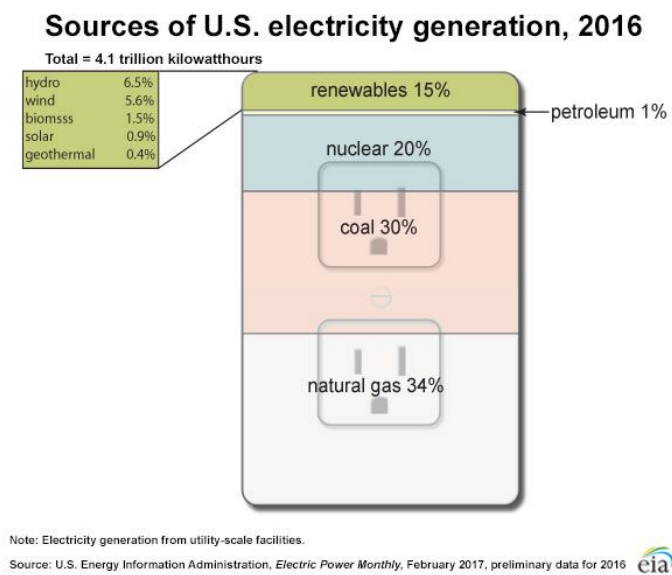

Figure 1: Sources of U.S. Electricity Generation, 2016 [2]

REQUIREMENTS AND SPECIFICATIONS

Table I: Engineering Requirements and Specifications

Engineering Requirement	Justification
<p>High voltage 3 prong 120V AC output from the system.</p>	<p>This provides the user with the ease of using their at regular electric vehicle charger that they would normally use at home.</p>
<p>Durable base System must be able to be installed on any terrain and capable of withstanding any weather and remain online and stable.</p>	<p>The system must be able to withstand normal, everyday use in the elements in order for it to be practical.</p>
<p>Large battery capability Battery capability must be enough to provide vehicles with a generous charge when it the battery is full.</p>	<p>In order to get the most out of this system, the battery must be large enough to provide enough charge to the electric vehicle in the case the user wants a quick charge.</p>
<p>Current flow measurement The system must be able to display how much current is entering and leaving the battery.</p>	<p>Total current flow shows the user the state of the system. This indicator allows the user to know the status of the battery which is going to be important when charging their electric vehicle.</p>
<p>System protection The system shall have some sort of protection set in place to prepare against faults and provide a quick disconnect.</p>	<p>System protection is necessary to protect the user and the system itself.</p>

DESIGN

Our design was limited to what resources were available for us. Luckily, the majority of the equipment for this system was provided by our advisor, Dale Dolan, and the Electrical Engineering Department. We originally envisioned a much larger system with multiple solar panels and batteries to provide a quick charge time for the electric vehicle but we quickly realized that the amount of materials required would put us way over our \$400 senior project budget. We ended up using only one 435 W solar panel and a 1.2kWh deep cycle battery. The stand for our project was even from an older student's senior project.



Figure 2: Solar Panel Cart

The only equipment we had to purchase ourselves was a deep cycle battery and the circuit breaker. Despite all of this, we were still able to provide an AC 120 V output that allows current to be drawn in a surprisingly fast manor.

We came up with the design of the system with the help of our advisor over the span of winter and spring quarter. With his vast knowledge in this field, he helped us incorporate system protection and a way to display the total current entering and leaving the system using a clever wiring technique, a shunt resistor, and a battery monitor. The basic components of the design were simple and logical in what would be needed to convert solar energy into battery energy, then be able to discharge the battery's energy to be available for and used by the electric vehicle.

The final design can be found in **Appendix B**.

INTEGRATION

1. Connect solar panel to charge controller.
 - a. Crimp MC4 connectors to 14 AWG wire and make a connection to the positive and negative terminals of the solar panel.
 - b. Strip the other end of the 14 AWG wires and connect it to the designed PV+ and PV- wire terminals of the charge controller as shown below:

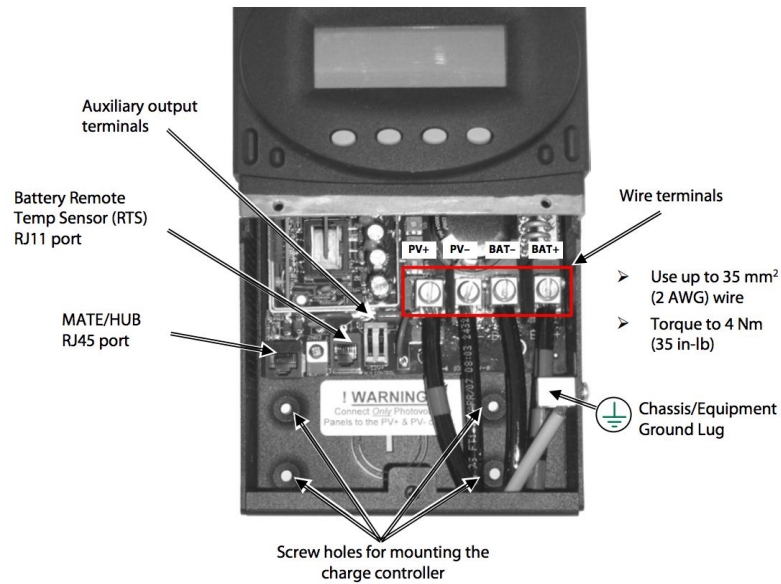

Figure 3: Wiring Diagram of Outback Flexman 80 MPPT Solar Charge Controller [3]

2. Connect charge controller to circuit breaker and battery
 - a. Strip the end of a 4 AWG wire and connect one end to the BAT+ terminal.
 - b. With the other end of the 4 AWG wire, attach a wire connector and attach it to one side of the 100A circuit breaker.



Figure 4: Wire Connector [4]



Figure 5: Circuit Breaker Connection Terminals [5]

- c. Do the same with another 4 AWG wire, but this time attach a wire connector to both sides of the wire.
- d. Now connect one end of this wire to the opposite terminal of the circuit breaker and the other end to the positive terminal of the battery.
- e. For the negative terminal, strip one end of a 4 AWG wire and make a connection in the BAT- terminal of the charge controller.
- f. With the other end of this wire, attach a wire connector on. This end of the cable will connect to the shunt resistor.



Figure 6: Battery Terminals [6]

3. Installing the battery monitor
 - a. Connect the end of the 4 AWG cable that is coming from the BAT - terminal of the charge controller to one of the top connections of the shunt resistor.
 - b. On the other side of the shunt resistor, strip and crimp a 2/0 wire and make a connection to the negative terminal of the battery.



Figure 7: Shunt Resistor Terminals [7]

- c. Open up the battery monitor and strip four 24 AWG wires and feed them into G1, G2, SIG, and B1+.
- d. Locate the side connection lug on the shunt resistor.
- e. Connect SIG to the side closest to the negative terminal of the battery.
- f. Connect G1 and G2 to the opposite side.
- g. Connect B1+ to the positive terminal of the battery using the fuse connector provided.

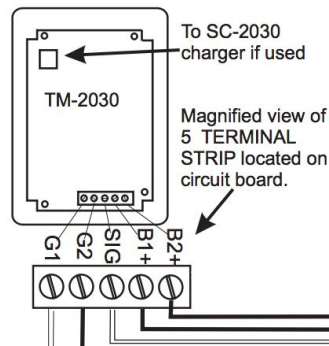

Figure 8: Back View of the TriMetric Battery Monitor Panel [8]

4. Installing the inverter
 - a. Attach a wire connector to one end of two 2/0 wires.
 - b. On the other side of both of the wires, attach a wire disconnect connector to provide a safe way to connect the circuit.
 - c. Repeat this process so you have two pairs of a male/female disconnect connectors to a wire connector.
 - d. With a wire with a male disconnect, make a connection to the connection of the shunt resistor furthest from the negative terminal of the battery.
 - e. With the other male wire, make a connection to the positive terminal of the battery.
 - f. Connect the wires with female disconnects, to the positive and negative terminal of the inverter.
 - g. Connect the wire that is connected to the negative terminal of the inverter to the wire connected to the connector on the shunt resistor farther from the negative terminal of the battery.

- h. Connect the wire that is connected to the positive terminal of the inverter to the wire connected to the positive terminal of the battery.



Figure 9: View of the Disconnect Cables



Figure 10: Inverter Connectors

TESTING

Testing this system was done in multiple stages. We first connected the battery to the inverter to see if the electric vehicle we used for testing (Ford Focus) would have an issue with the lack of ground in the system.

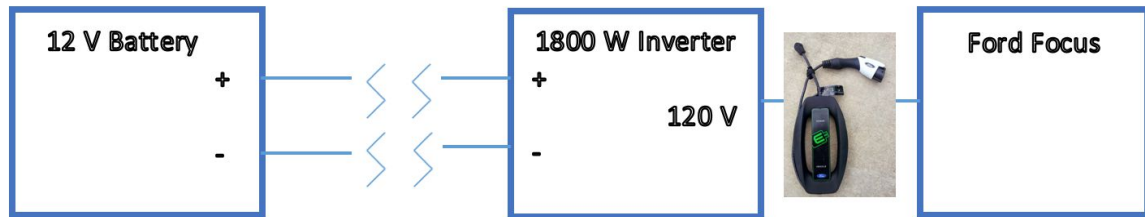

Figure 11: Battery to Ford Focus Connection

Once we saw the Ford Focus was charging (noted by a blinking light on the charger) we decided to move on and work on the front end of our system. Our next move was connecting the charge controller to circuit breaker and powering it with the battery.

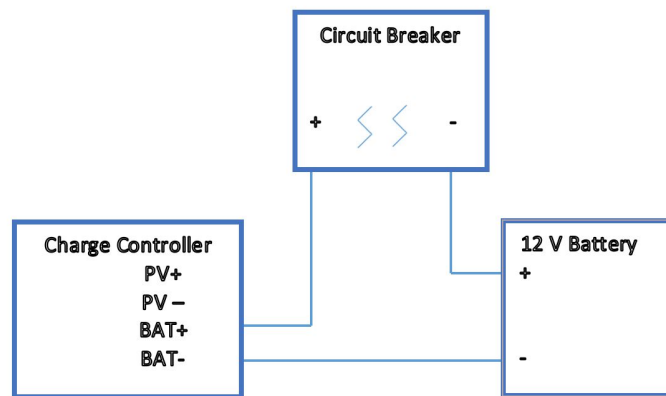

Figure 12: Charge Controller to Battery Connection

The charge controller appeared to turn on as expected. Next, we set up the battery monitor and configured it to our 12V battery size.

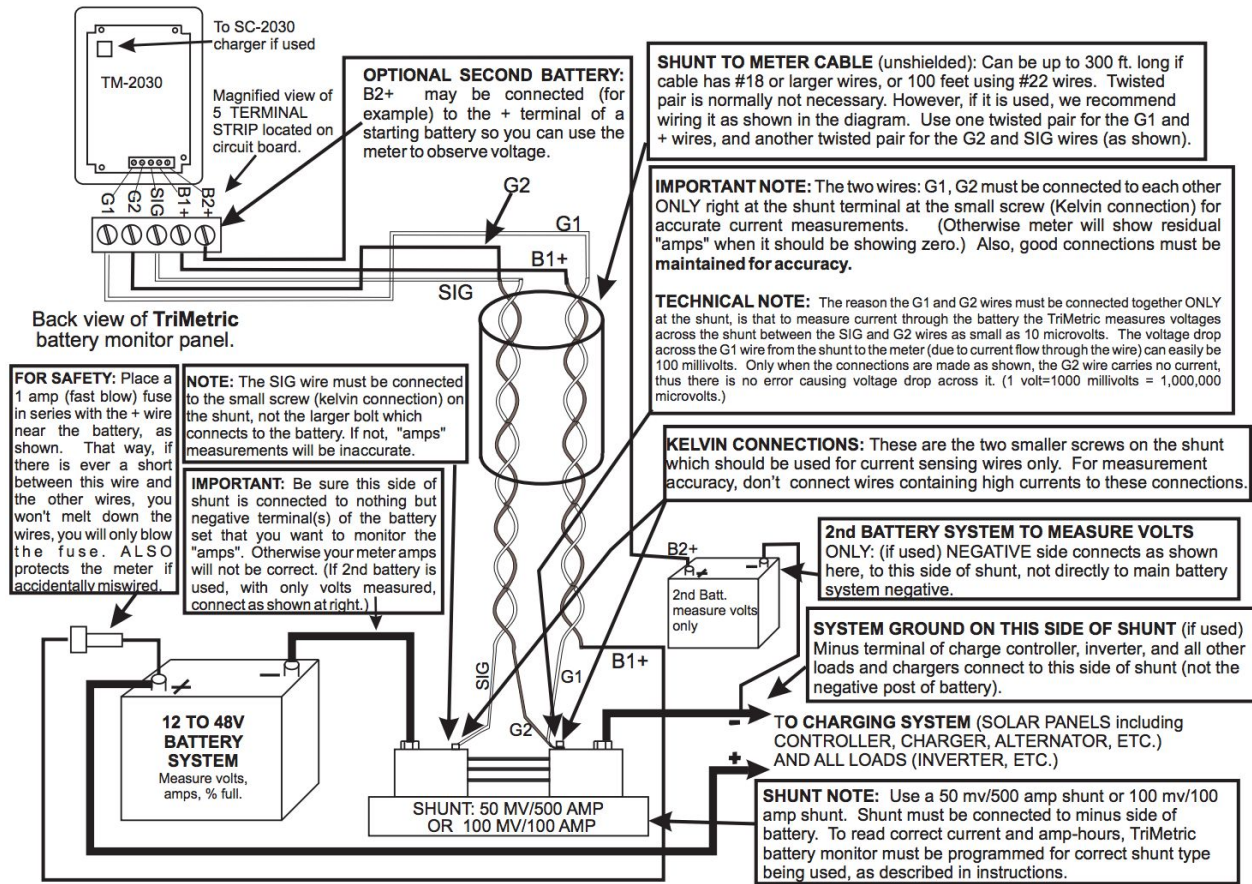

Figure 13: Battery Monitor to Battery Connection [8]

The battery monitor was displaying the proper voltage (~12V) and zero current (which is correct since there was no load in this connection).

After testing each individual part of our system, we decided to tie everything together with the solar panel. The solar panel used was a part of a previous senior project and is located on a dual-axis adjustable rack (see **Figure 1**).



Figure 14: Complete Solar Powered Electric Vehicle Charger as Shown in the Senior Project Expo

Once everything was connected the system immediately started charging the Ford Focus. The numbers recorded that day is shown below:

Charge controller
IN: 55-63V (fluctuating), 6.1A
OUT: 11.4V, 28.6A

Battery Monitor
Charging car: 11.4V, -112A
No load: 12.7V, +25.9A

Inverter
11.1 Vdc, 135-138A
AC Watts, 1250

We knew the battery monitor was operating correctly in the preferred orientation (displaying $I_{CC} - I_{INV}$) because we were reading a negative current when the car was charging and a positive current when we disconnected the load.

From this information, we came up a time-to-charge calculation.

12 V Battery:

Panel power: 300-400 Wh

Time to charge 1.2 kW battery: 3 - 4 hours

Ford Focus:

Ford focus has a 6.6 kW battery size and 115 mi range.

Our battery is 1.2 kWh.

The Ford focus would be charging at a rate of *1.5 kWh* but the battery only “sees” it being discharged at a rate at about *1.25 kWh* due to the solar panel charging the battery as it’s being depleted*.

This means that the battery in our system will only last about 1 hour before it is discharged completely.

This in return proves a “fast charge” of about 26 miles in 1 hour.

$$115 \text{ mi range} / 6.6 \text{ kW} = 17.42 \text{ mi/kW}$$

$$(17.42 \text{ mi/kW})(1.5 \text{ kW}) = 26.13 \text{ mi}$$

Once the battery is depleted, the EV will no longer charge as fast. This is because the EV will be charged directly from the solar panel at a rate of 300 - 400 Wh under direct sunlight.

With Battery: 1 hr @ 1.5 kWh

Remainder of car battery: 6.6kW - 1.5 kW = 5.1 kW

Charging the remainder of the battery with just solar panel:

$$5.1 \text{ kW} / 0.300 \text{ kWh} = 17 \text{ hours @ } 300 \text{ Wh}$$

$$5.1 \text{ kW} / 0.400 \text{ kWh} = 12.75 \text{ hours @ } 400 \text{ Wh}$$

Total time to fully charge battery: **13.75 - 18 hours****

Table II: Time to Charge (Current system)*

Battery	3 - 4 hours
Ford Focus	13.75 - 18 hours

*Assuming we have a fully charged battery, fully depleted ford focus, and under direct sunlight

**Note that this would not be possible to charge the remainder of the battery in one day as there is approximately 14 hours of sunlight per day in San Luis Obispo this time of year [9].

CONCLUSIONS

This senior project has taught us both a tremendous amount about renewable energy, systems engineering, and electric vehicles. On top of this, we both feel that we have improved time management, organization skills, and teamwork. Despite the speed bumps with finding the resources to complete this project, we would say that we are both pleased with our efforts in producing a working prototype for the senior project expo.

One thing we would like to emphasize is how unpractical the system is with just one solar panel and battery. We discovered that it could take almost *18 hours* under direct sunlight to fully charge a ford focus with our system. This is impossible at any time of year in San Luis Obispo, where there's only 14 hours of daylight and those hours of sun aren't efficiently collected by a solar panel, even with a dual-axis tracker built into the system because it will not likely achieve direct sunlight. This means that this system will take multiple days to fully charge an electric vehicle, and no one would realistically use that type of charger when they could much more easily plug it into an electrical outlet and charge in just a few hours.

With just adding one extra solar panel and battery in parallel with its kind, it cuts the time to charge in more than half.

Table III: Time to Charge (Improved system)***

Battery	1.5 - 2 hours
Ford Focus	6.5 - 8 hours

****Assuming we have a 2 fully charged batteries, fully depleted ford focus, and 2 panels under direct sunlight*

This is a huge improvement in overall system efficiency and becomes a much more practical system. The extra batteries are essential to keep the voltage above the shut-off level that the inverter activates. During the senior project expo, as the Focus was being charged with this system, when the inverter voltage dropped to around 10.7 V, it would no longer allow the Focus to draw current and charge the vehicle. This took a matter of hours, if not less than a full hour to occur. This is a major flaw in the system, with an easy remedy of adding more deep cycle batteries to the system. With a higher budget or additional resources we could've built upon our system to make it more practical for consumer use, but we are happy with a working finished product.

We'd like to give a big thanks to our advisor, Dale Dolan, for sticking with us throughout this year and being a great help with the design, construction, and allowing us to borrow so much of his personal resources. We truly could not have done this without him and we wish him the best in his future endeavors.

REFERENCES

- [1] MarketWatch, “Electric Vehicle Charging Station Market”. [Online]. Available: <http://www.marketwatch.com>. [Accessed: June 8, 2017].
- [2] U.S. Energy Information Administration, “Electricity in the U.S.”. [Online]. Available: <https://www.eia.gov>. [Accessed: June 8, 2017].
- [3] Outback Power, “FLEXmax Series Charge Controllers,” FLEXmax 80, FLEXmax 60 Owner's Manual, Feb. 2012.
- [4] Lowes, “Hillman 4-Count Ring Wire Connectors”. [Online]. Available: <https://www.lowes.com>. [Accessed: June 8, 2017].
- [5] Powerwerx, “Resettable Circuit Breaker Cooper Bussmann”. [Online]. Available: <https://powerwerx.com>. [Accessed: June 8, 2017].
- [6] BatteriesPlus, “Deep Cycle 100AH AGM Battery Duracell Ultra 12V SLA Sealed Lead Acid”. [Online]. Available: <https://battiesplus.com>. [Accessed: June 8, 2017].
- [7] Solar-Electric, “Deltec 500 amp, 50 millivolt current shunt”. [Online]. Available: <https://www.solar-electric.com>. [Accessed: June 8, 2017].
- [8] Tri-Metric, “Battery system monitor,” INSTALLER’S INSTRUCTIONS FOR TRI-METRIC, Jan. 2015.
- [9] Timeanddate, “San Luis Obispo, California, USA — Sunrise, Sunset, and Daylength, June 2017”. [Online]. Available: <https://www.timeanddate.com/>. [Accessed: June 8, 2017].

APPENDIX: A — ANALYSIS OF SENIOR PROJECT DESIGN

Project Title: Solar Powered Electric Vehicle Charger

Student's Names: Jessica Bombardier Shaw, Andrew Moradpour

Student's Signatures:



Advisor's Name:

Dale Dolan



Date: 6/9/17

A. Summary of Functional Requirements

- I. The system shall provide fast, reliable, and clean energy to an electric vehicle.
- II. The system shall obtain its energy via a solar panel and store it using batteries.
- III. The system shall be compatible with all electric vehicles.

B. Primary Constraints

- I. The main difficulty was obtaining all materials necessary to implement the design. Most of the equipment required cost more than \$200 each, and the Cal Poly senior project budget is only \$200 per person.
- II. Our budget limited the amount of battery storage space available to use which in turn limited how fast we could charge an electric vehicle
- III. Physically, the solar cart we were using could only support one solar panel. This affects the input power in the system.

C. Economic

- I. **Human Capital** – This system requires a small amount of engineers to oversee production. There will be troubleshooting involved along with a continued effort to increase efficiency and reduce costs.
- II. **Financial Capital** – There will be a large amount of investment needed up-front to initialize manufacturing of this system. It is also unclear what the market for this type of product might be or the price prospective customers would be willing to pay for it at this time. The initial price might be much more than a customer is willing to pay and then the business would not be able to maintain production. It might be too soon for a product of this kind to be on the market. But, for an individual willing to make a personal investment and create this system themselves, the return on their investment will be great by reducing their electricity bill from their EV charging costs.
- III. **Natural Capital** – This product will utilize several electrical components including a solar panel, a battery, and an inverter. The design is meant to reduce carbon emissions caused by utilities that still burn fossil fuels which in turn powers electric vehicles, but

there is an environmental impact in regards to production of solar panels and mining for solar cell resources, along with the other metals and elements involved with the electronics of the system. Proper recycling of these components would be encouraged and accepted as we are marketing to environmental conscious consumers.

IV. Manufactured Capital -- All components used in this system are manufacturable components. The cost would reduce tremendously if the system was manufactured rather than individual components being purchased and assembled by hand. There will be an increase in jobs related to power systems, power electronics, manufacturing, and sales.

Where/when costs/benefits accrue:

The costs will all be upfront with the purchase of components for the system. There may be additional costs down the line as the battery and solar panel degrades (the Deep Cycle 100AH AGM Battery lifetime is 4-7 years and the 435W SunPower Solar Panel has about a 40 year lifetime). The benefits will accrue once the amount of electricity or cost for payments at public charging stations surpass the cost of the system. This exact amount of time will depend on the time of day the EV is normally charged at home and the cost of electricity at that time; the amount of charging done at public stations and the average amount paid; and the final cost of the system to the individual.

									USA
Sub	Sub	Sub	Sub	Description	Qty	Document	MFG	LT - Weeks	Price (USD)
Box Build - Model S1 - Retail Configuration					1	Instr	Custom	2	
1	Final Assy - Unit SunCharge				1	Instr	Custom	2	
	1	Main Assy			1	Instr	Custom	2	
		1	Solar Panels		4	Spec	LG	2	1200
		2	Pole Mount		1	Spec	Tycon	2	706.0000
		3	Batteries		6	Spec	Rolls	2	10500.0000
		4	Battery Enclosure		1	Spec	Radiant	2	549.0000
		5	Solar Inverter		1	Spec	Magnum	2	2239.2000
		6	Charge Controller		1	Spec	MidNite	1	570.0000
		7	Circuit Breaker		1	Spec	MidNite	1	44
		8	Battery Monitor		1	Spec	Magnum	1	175.2000
		9	J1772 Plug		1	Spec	SAE	1	166
									Materials 16149.4000

Figure 15: Original Estimate Cost

Solar Powered Electric Vehicle Charger

Part Count : 13
 Total Cost : \$2,906.84

Part #	Part Name	Description	Qty	Units	Picture	Unit Cost	Cost
1	<i>SunPower E20/435 Solar Panel</i>	<i>435 W Solar Panel</i>	1	1		\$ 800.00	\$ 800.00
2	<i>6 in. MC4 to Bare Conversion Cable Set</i>	<i>MC4 Connector Cables</i>	1	1		\$ 12.48	\$ 12.48
3	<i>24 AWG Gauge Stranded Hook Up Black 25 ft</i>	<i>24 AWG Cu Wire</i>	1	1		\$ 6.21	\$ 6.21
4	<i>14 AWG Gauge Primary Wire - 25 ft</i>	<i>14 AWG Cu Wire</i>	1	1		\$ 7.00	\$ 7.00
5	<i>4 Black Stranded CU THHN Wire</i>	<i>4 AWG Cu Wire</i>	1	1		\$ 3.44	\$ 3.44
6	<i>4/0-4/0-2/0 Black Stranded Al Sweetbriar URD Wire</i>	<i>2/0 Cu Wire</i>	1	1		\$ 8.36	\$ 8.36
7	<i>Outback FLEXMAX 80 MPPT SOLAR CHARGE CONTROLLER</i>	<i>80 A Solar Charge Controller</i>	1	1		\$ 554.51	\$ 554.51
8	<i>Xantrex Statpower Prosine 1800 GFCI</i>	<i>1800 W DC to AC Inverter</i>	1	1		\$ 1,021.99	\$ 1,021.99
9	<i>Deep Cycle 100AH AGM Battery Duracell Ultra 12V SLA Sealed Lead Acid</i>	<i>12v 100Ah Battery</i>	1	1		\$ 279.99	\$ 279.99
10	<i>Resettable Circuit Breaker Cooper Bussmann</i>	<i>80 A Circuit Breaker</i>	1	1		\$ 27.99	\$ 27.99
11	<i>Hillman 4-Count Ring Wire Connectors</i>	<i>Wire Connectors</i>	1	1		\$ 7.37	\$ 7.37
12	<i>Deltec 500 A, 50 mV Current Shunt</i>	<i>Shunt Resistor</i>	1	1		\$ 27.00	\$ 27.00
13	<i>Bogart Engineering TM-2030RV-F Trimetric Battery Monitor</i>	<i>Battery Monitor</i>	1	1		\$ 150.50	\$ 150.50
	Total		13				\$ 2,906.84

Figure 16: Actual Final Cost of Component Parts

Note: items in bold and italics were items owned by Cal Poly, the EE Department, or Dale Dolan. Items unitalicized/unbolded were items purchased by the students for the project and donated back to the department.

Earning and Profits

The intended use of the project is personal, at-home EV charging. From this project we would only earn based on the amount of money saved. Those selling the components profit, unless the entire system became manufactured by one company.

Timing

This is the perfect time for a product like this to emerge. Electric vehicles are on the rise and more people are becoming environmentally conscious and aware of their own carbon footprint. In addition to this, it is becoming more cost-effective for homeowners to install solar on their homes to reduce their electricity bill. The combination of these factors will lead more people to seek out ways to continue in being “green” and reducing energy costs while using clean energy options.

If manufactured on a commercial basis:

Estimated number of devices sold per year	= 100
Estimated manufacturing cost for each device	= \$2,906.84
Estimated purchase price for each device	= \$2,906.84*(1.3) = \$3,778.90
Estimated profit per year	= (\$3,778.892- \$2,906.84)*10 = \$8720.52
Estimated cost for user to operate device	= \$0

D. Environmental

- I. When manufacturing this system, the factory will consume additional power that may or not be the result of a renewable resource. If human workers are used at the plant, additional fossil fuels will be burned if they travel to work in a combustible-engine vehicle. Therefore, with each unit built, additional fumes and chemicals will be emitted to the environment.
- II. There is environmental impacts and concerns in mining the elements used for the solar cells. To reduce that, the optimal solar panel would be one that created their cells using recycled glass for the silicon cells.
- III. The natural resource/ecosystem impact would be minimal. If the system was installed on a stand on one’s property, the stand dug into the ground would be no more damaging than a light pole installation and the solar panel mounted on top would be no more impactful than a backyard patio set umbrella. Most people would likely choose to install the solar panels to their roof, eliminating both these concerns.
- IV. The project is intending to help the environment by increasing the appeal of electric vehicles, reducing the amount of energy required on a utility system to charge these cars, and reduce the amount of fossil fuels required to meet the demands of the system. Overall, the intention is to reduce carbon emissions and create a completely clean electric vehicle.

E. Manufacturing

- I. We estimate that we will sell a few amount of these devices initially (average of ~5 units/yr) and then after a few years reach some sort of linear progression (15 units/yr).
- II. The estimated manufacturing cost can be taken from our bill of materials: \$2,906.84. Later in our products lifetime we will have a larger demand for our product so we can begin to buy in bulk from the manufacturer in order to save money.
- III. The problems we may face while manufacturing this system is finding top of the line manufacturers that we can rely on to provide us with a safe and sturdy product that is also cost-effective and produced in the most environmentally-friendly way.

F. Sustainability

- I. There is degradation expected with the components of the system. The lead acid batteries we will using tend to last 4-7 years depending on the amount of use. After that, they will need to be replaced. It is also wise to have the battery checked for leaks periodically. Additionally, it is also expected that the solar panels will degrade and lose efficiency after 20-40 years. It is also encouraged to maintain panels by cleaning and checking for damages periodically.
- II. The solar panels needed for this project contributions to the supply of silicon that we have on this planet. Luckily, Silicon is a very abundant element and makes up a large chunk of the earth's mass. On top of this, additional metal would have to be mined in order to make up the system's build. As of today, the components used for the system are considered sustainable. There will need to be a continued effort in electronics and metallurgic recycling to ensure these components remain sustainable.
- III. The most important upgrade on the current system would be to add additional batteries. As the system is, it can not fully charge an electric vehicle. The addition of batteries and possible solar panels will allow the system to charge the electric vehicle in a more reasonable amount of time.
- IV. Some possible issues or challenges associated with upgrading the design would be additional material costs & maintenance fees that would have to be added to the total cost of the product.

G. Ethical

- I. The use of this product promotes clean and renewable energy. In order to uphold these positive implications, all processes along the way must be clean and ethical.
- II. There could be ethical implications if the system was installed on a stand and created shading or hindered views of one's neighbors.

H. Health and Safety

- I. The idea of the system is to reduce carbon emissions from combustion vehicles and electric utilities that get their fuel from nonrenewable sources. As small of an impact as this project might make in the overall scheme of things, it is important nonetheless as it helps reduce harmful emissions.
- II. There may be concerns with the current manufacturing process of solar panels and other electronics used in the system. These concerns would need to be studied and addressed if the project was manufactured.
- III. The system itself shall be sturdy and safe to operate to avoid any damages that may occur to an operator. To ensure this, our manufacturers must have proof of a safe workplace for all of their

workers and a quality assurance team that prevents defects in our materials used that may cause issues to our consumers.

I. Social and Political

- I. The main impact this project would have on society would be a positive one. An electric vehicle powered completely by the sun promotes the use of electric vehicles and the production of energy in a clean and responsible manner.
- II. There might be delay on efforts to expand electric vehicles and reduce fossil fuel use with the current US administration. This might have repercussions on products that encourage the use of renewable energies over fossil fuels. The exact impact of this is currently unknown. This project is currently the best option for an individual to own and produce electricity on their own.

J. Development

- I. Developments that are currently being worked towards are:
 - A. More efficient/cheaper commercial solar panels
 - B. More efficient/cheaper energy storage
 - C. DC Supercharging
- II. From these developments, electric vehicles (along with renewable energy) will become more abundant.

APPENDIX B: PROJECT SCHEMATIC

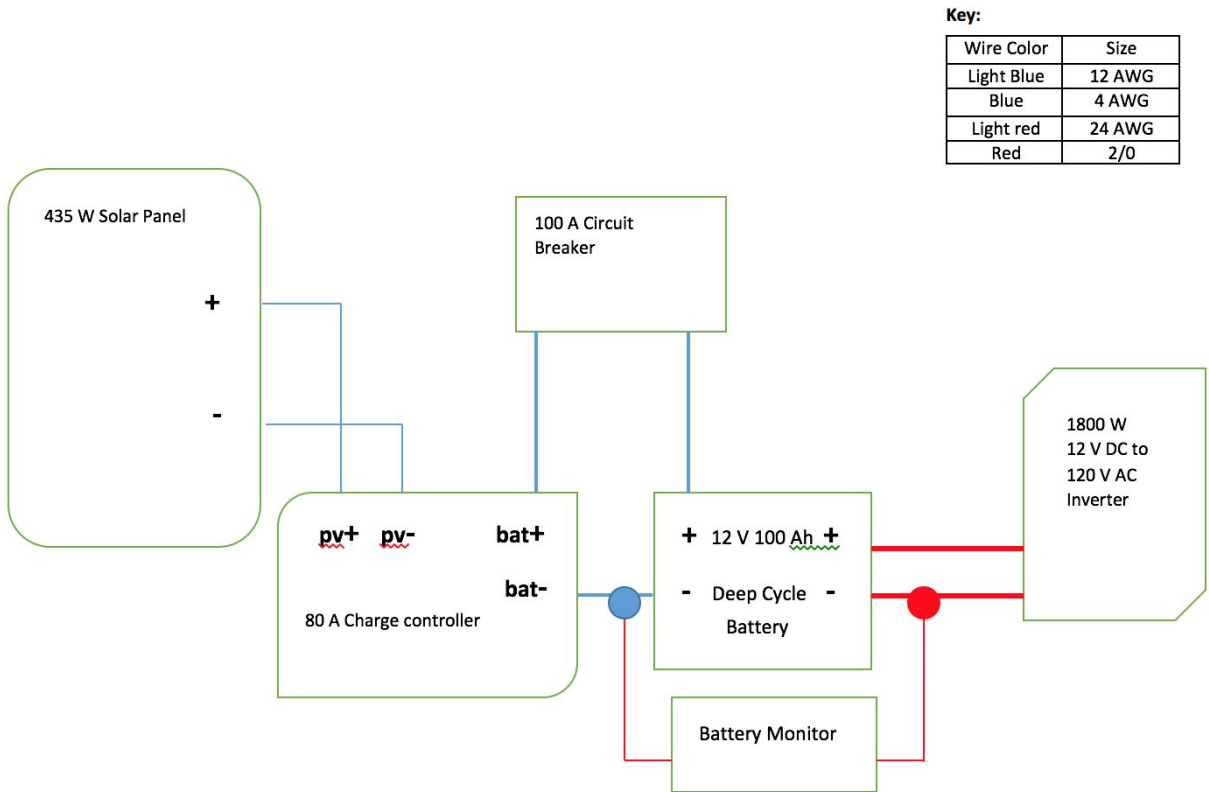

Figure 17: Final Design of the Solar Powered Electric Vehicle Charger

APPENDIX C: TIME SCHEDULE ALLOCATION

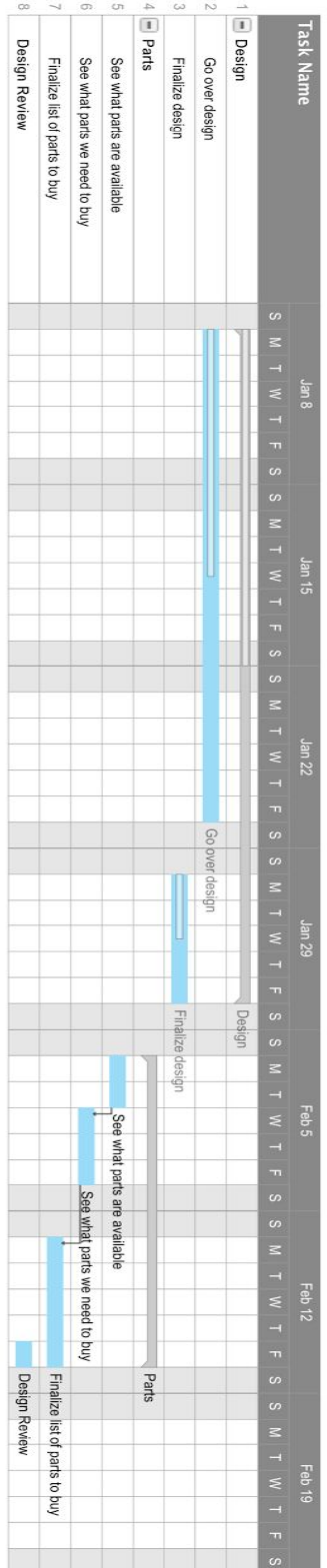

Figure 18: EE 461 Gantt Chart

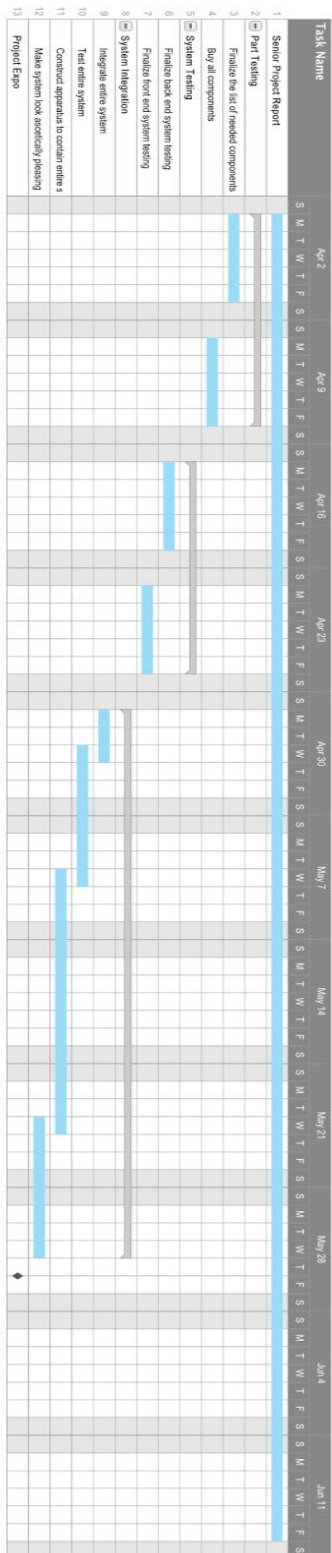

Figure 19: EE 462 Gantt Chart