



California Polytechnic State University, San Luis Obispo

The Atascadero Printery

Prepared for: The Printery Foundation

Prepared by: Kaylee Efstathiou, Jami Hahn, Tyler Pizarro,
Elizabeth Townsend, Mark Luzi

8, May 2017

Preface



The Building:

FIGURE 1A

The Atascadero Printery is a historic city building built in Atascadero, California. The building was damaged heavily during the San Simeon earthquake in 2003 and has since been abandoned. Recently, the Printery Foundation was established in hopes of preserving, purchasing and renovating the building for future generations.

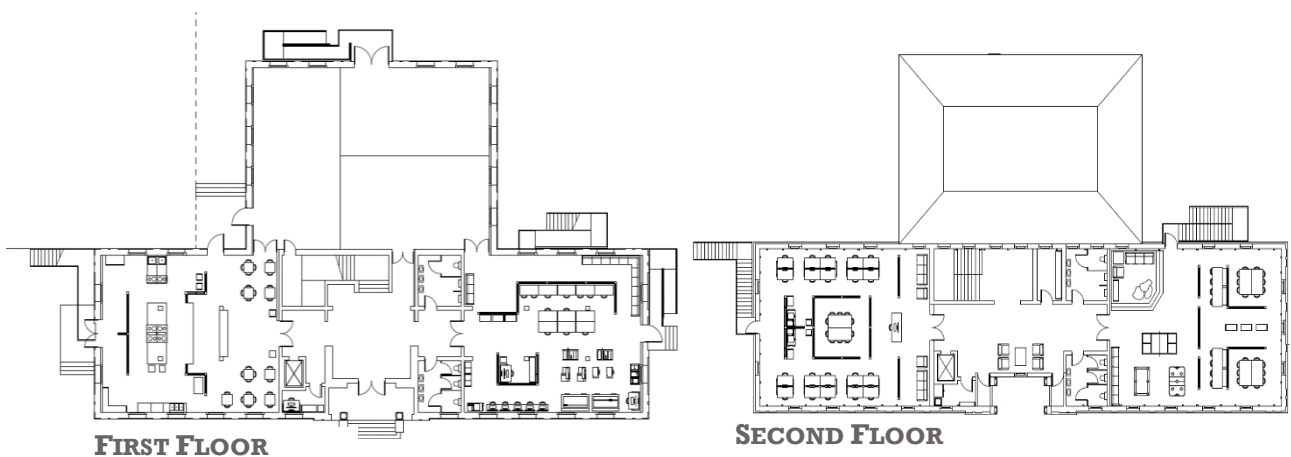

FIRST FLOOR

SECOND FLOOR

The Project:

We have put together a proposition for bringing a new life to the building. This proposition includes evaluating the existing structure, proposing solutions to fix structural issues and creating a new layout of use for the building. Our work would provide the Printery Foundation material to use for fundraising purposes. Through this project, the hope is to illustrate to the people of Atascadero how important this building is to the community and to maintaining the history of the central coast.

Table of Contents

Preface	1
The Building:	1
The Project:	1
Introduction	3
Dedicated To	3
Who We Are	3
History	4
How We Got Involved	5
Our Proposal	6
Architectural Site	6
Architectural Program	6
Structural Evaluation Criteria	7
Structural Evaluation Results	7
Structural Recommendations	9
Conclusion	11
The Building's Future	11
Awareness	11
References	12

Introduction

Dedicated To

Our advisors

ARCE- Jill Nelson, SE, PMP, LEED AP – Associate Professor

ARCH- Dale Clifford, AR, LEED AP – Assistant Professor

The Printery Foundation | <http://www.atascaderoprintery.org/>

Karen McNamara – President

Chuck Dunlap - First Vice President

Jenny Kim - Second Vice President

Nicholas Mattson - Treasurer

Kat Dunlap - Secretary

Amber Long - Member, Architectural Historian

Others:

Lee Engelmeier, PE - Principal at Smith Structural Group, LLP

Brent Nuttall, SE - Full Professor

Kelle Brooks, AR, LEED AP - Lecturer

Who We Are

ARCE:

Kaylee Efstathiu, 4th year

Jami Hahn, 4th year

Tyler Pizarro, 4th year

ARCH:

Elizabeth Townsend, 4th year

Mark Luzi, 4th year

History

This project strives to save and revitalize one of Atascadero's oldest buildings, The Printery, by transforming this damaged and abandoned structure into an epicenter of education and culture for the community. At just over one hundred years old, built in 1912, this building has taken on multiple programmatic roles within the city throughout its history, including a Women's Printery, junior college and a Masonic Lodge. Its functionality was cut short however, during the San Simeon earthquake in



FIGURE 1B

2003 when it became unsafe to occupy due to structural damage. Plans were made to abandon the site and auction off the land, but were reversed in hopes that The Printery Foundation, a nonprofit group dedicated to the preservation of the landmark, could find a suitable strategy for the redevelopment of the site and building. In recent years, vandals and natural processes have defaced the building. The Printery Foundation has held clean up days and fundraising events in hopes of preserving, purchasing and renovating the building for future generations.

From the construction of the building, there have been multiple uses and owners. The first owner, E.G. Lewis along with his brother George B. Lewis, used the building as a Women's Printery producing the paper known as *The Illustrated Review* and later the *Atascadero News* until the building was sold until the mid-1920's. It was sold to Frank Moran to serve as the southern satellite campus for an exclusive boy's prep school. In 1950, it was purchased by the Masonic Temple Association and served as the meeting place for the Atascadero Masonic Lodge into the 21st century. In 1994, the building was given to the City of Atascadero. The 2003 San Simeon Earthquake caused a significant amount of damage and due to a lack of finances to bring the building up to code, the city returned the building to the Masons in 2005. The building eventually ended up in the hands of former North County developer Kelly Gearhart. Gearhart was convicted in May 2014 of fraud and the building was put up for auction by the City of Atascadero. The building has since been removed from auction and The Printery Foundation has been raising money to buy, restore, and repurpose the building.

Being over one hundred years old, the building is eligible for listing on the National Register. This allows the building to be protected under the standards for the Treatment of Historic Properties from the National Park Service, which oversees the treatment of cultural resources. According to Amber Long, a member of the Printery Foundation and an Architectural Historian, the building has not been approved for listing because of problems over ownership of the building. It is the hope of the Foundation to obtain ownership of the building and have it listed on the National Register.

How We Got Involved

California Polytechnic State University (Cal Poly) is a public university located in San Luis Obispo, California. At Cal Poly, the Architectural Engineering (ARCE) department is an entity within the College of Architecture and Environmental Design. Students within in the ARCE program need to complete an interdisciplinary senior project as part of their curriculum.

As a senior in need of a senior project, Kaylee Efstathiou went to associate professor Jill Nelson in hopes of receiving an idea for a project that would be interesting and insightful. Jill Nelson had the perfect project in mind, a project involving an existing building in Atascadero that was in need of a lot of TLC and a group of students to come up with a new life for the building. This was exactly the type of project Kaylee Efstathiou had been hoping for because it involved working on an already constructed building and helping the local community. Project idea in hand, Kaylee Efstathiou reached out to fellow architectural engineering students Jami Hahn and Tyler Pizarro, as well as Architecture students Elizabeth Townsend and Mark Luzi, who all were equally interested in the project and the team was formed.

Once our team was established, we met with members of The Printery Foundation to find out their hopes for the building. At this meeting, we were tasked with developing a design that blends the landmark's past with the city's contemporary needs. This design would make a special effort to respect the site's historical patrimony. In order to complete this design, the building needed to be seismically retrofitted. Choosing to retrofit rather than redevelop fulfills defines the design as a necessary action as opposed to a desire for additional built space. Through design, this project can become an example of how preservation can benefit a community and solidify the ideas of the past in our modern society.

Cal Poly's Architectural Engineering department strives to find projects locally that help the community in some way. This project will help the Printery Foundation with their efforts in presenting this building to the community for fundraising by illustrating how this building is not just important to the local community but to maintaining the history of the central coast as well. As a team, it was our hope for the project to be a benefit to the Foundation as they move forward in their goal of purchasing, renovating and repurposing this iconic building.

Our Proposal

Architectural Site

The site is located in the center of Atascadero, California on the border between residential neighborhoods and natural landscape (1). Adjacent to various locally beneficial projects, City Hall (2) and Atascadero Middle School (3) among them, The Printery serves as an important link between the community and these institutions. The building and the land associated with it will be designed to respect existing conditions while giving new use to the land furthering this connection. On the northern side of the pre-existing building stands a gymnasium, an addition to the original building, which will be removed in the future (see sheet A2 for location of the gymnasium). The goal of this project will be to bring back the original shell of the building and allow for additions in the future.

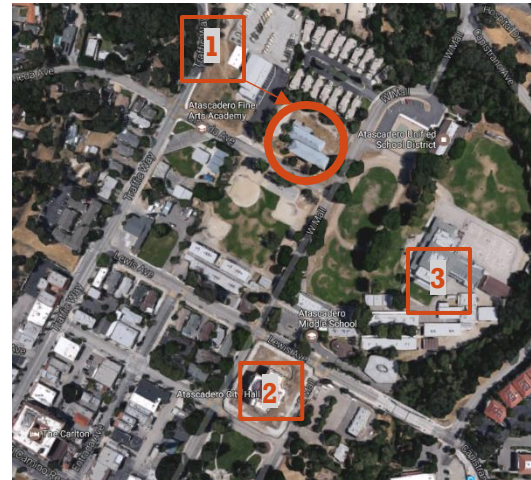

SITE MAP

Architectural Program

The program of the project will be centered on creating usable space for the community, which in turn will foster art, technology education, and historical appreciation. Although the focus is on restoring the building, the program will be distributed between the existing structure and the surrounding outdoor space. With the gymnasium removed from the site, a plot of land will be left open for an addition of the Printery Foundation's choosing in the future. The remainder of the site will be developed to add parking for building, community gardens, event spaces, and barbecue pits as shown on sheet A3 of appendix A.

The interior of the building will be developed to have an open floor plan highlighting the original structure. Using the symmetry of the building and the layout of the windows, a grid system was developed to create new spaces throughout the building (see sheet A4-A6 for a more detailed description of how this was accomplished). The new spaces created with this grid system feature public spaces on the ground floor including a community kitchen, café, educational workspace, gallery, and event space. Private spaces including office facilities, and gathering areas will be located on the second floor to address security. The addition of these spaces created a need for additional accessibility to the building which will be added to the building in the needed locations while preserving the original entryway (see sheet A4 for locations of access points). To keep the open layout floor plan the creation of modular partitions was added. The goal of the partitions will be to create the spaces mentioned above and not intervene with the existing structure. A more detailed description of the modular partitions can be found on sheets A8-A10 of Appendix A. In addition to creating a community epicenter, these elements will act as an attractor for outside visitors, and enhance the surrounding area.

Structural Evaluation Criteria

In order to seismically retrofit the building, the structure's existing conditions need to be evaluated. The criteria of this evaluation is based on ASCE 41: Seismic Evaluation and Retrofit of existing Buildings.

For a retrofit of an existing building there are a number of structural and non-structural components that need to be evaluated. The benchmark code (IBC 2000) for unreinforced masonry buildings was established in 2000. The Printery was built in 1912 so it is not considered a benchmark building. This means that the building needs to be evaluated under certain criteria. The building also has a high level of seismicity based off of the United States Geological Survey report. It is a risk category II structure which is a risk category that encompasses most commercial buildings. Because of this, the building requires a tier 1 evaluation to comply with the requirements of ASCE 41. A tier 1 evaluation is based on existing construction documentation yet subject to the findings of on-site investigations. Our evaluation was based off of two site visits in winter 2016 and the original construction documents from 1912 that were obtained through the city of Atascadero. This evaluation is considered to be level 3-C. Level 3-C is an evaluation that allows life safety performance of both structural and non-structural elements. Life safety structural performance is a performance level of the building system that allows for the safe exiting of building occupants. This performance level does not guarantee continued occupancy before repair.

Structural Evaluation Results

The Atascadero Printery is an unreinforced masonry (URM) building. It is comprised of two different parts. There is the main building and the pool room. The pool room is located north of the main building and it is only one story with a wooden roof. The main building is two stories. The second level has a concrete slab that is at the same level as the wooden roof in the pool room. The roof level of the main building is another wooden roof. In a structure, the gravity system resists gravity (vertical) loads and the lateral (horizontal) system resists seismic loads. The gravity system in the Printery is comprised of wooden and steel trusses, concrete slabs, URM bearing walls, and concrete columns. The lateral system is made up entirely of URM walls that receive seismic loads from concrete and wooden diaphragms. A diaphragm is horizontal element that can be flat or sloped to transferring lateral loads. For the goal of this project, there was a focus on the lateral system of the structure due to seismic loading.

The building has various notable structural deficiencies. All of these deficiencies involve the capacity of the unreinforced masonry walls and the connections to them.

The load path, or how the load from an element travels through the building, is insufficient in various places involving connections to the URM walls. There are no existing wall anchors attaching the URM walls to the wooden diaphragms. The steel



FIGURE 2 – POOL ROOM TRUSS CONNECTION

trusses also lack a sufficient connection because they are embed into the URM in some places. This is a problem because the seismic load of the URM walls will be concentrated on these truss connections in a seismic event. This could have been what caused the structural damage seen in figure 2.

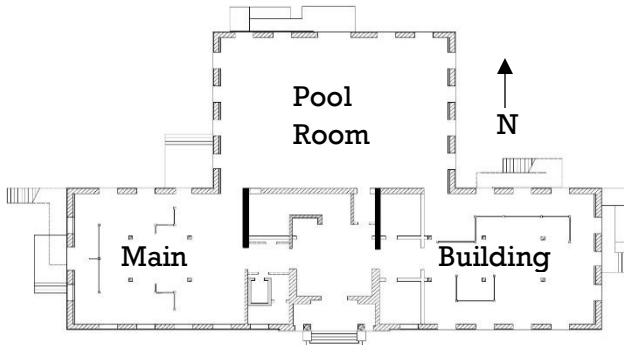

FIGURE 3 – 1ST FLOOR SLENDER WALLS

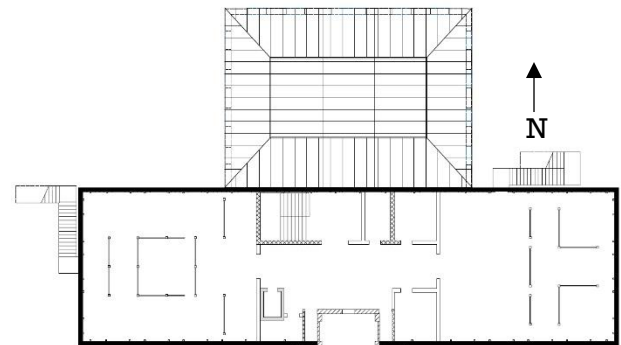

FIGURE 4 – 2ND FLOOR SLENDER WALLS

The structural capacity of the URM walls is inadequate in some areas of the building. The nine-inch thick walls on the 1st floor and the thirteen inch walls on the 2nd floor (shown in figures 3 and 4 as the dark black lines) do not meet the height to thickness ratio requirements of ASCE 41. This means that the walls are too slender and would likely fail under out of plane seismic loads. An out of plane seismic load is the load caused by the weight of the wall itself.

As for in plane seismic loads (loads that are applied along the walls), most of the walls have an adequate capacity with the exception of the walls in the plan north and south direction on the first floor shown in figure 5 as the darkened black lines. The estimated capacity of the URM walls was calculated to be less than the seismic demand (load expected in a seismic event).

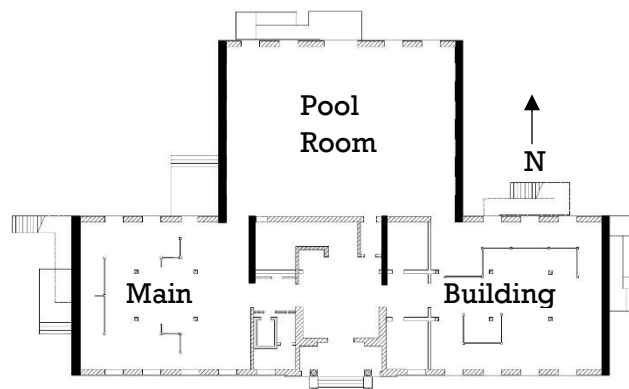

FIGURE 5 - INADEQUATE WALLS FOR IN PLANE SEISMIC LOAD (1ST FLOOR)

This inadequacy can be the reason for shear failure in the walls during a seismic event. Shear failure in URM is when there is cracking and sliding with the mortar joints of the walls due to load that is applied along the walls.

The outer layer of brick on the building is considered a veneer layer. This veneer layer is hazardous as the brick can fall off the walls during an earthquake.

The existing diaphragm sheathing panels are inadequate for the pool room roof and the main building second floor roof. The aspect ratio, comparing the length to the width for unblocked diaphragms at the second floor roof is also inadequate.

Structural Recommendations

The proposed structural recommendations include the addition of strongback columns, shotcrete walls, wall anchors, veneer anchors, and new layers of sheathing throughout the building.

We recommend installing strongback columns along all of the walls on the second floor as well as the nine inch thick walls on the first floor of the building (see appendix S sheets S1 and S2 for locations and connection details). Strongback columns are used to brace the walls reducing the potential for out of plane failure. The span of the URM would be decreased to the maximum spacing of the strongbacks which is six feet. In order to transfer the URM load to the diaphragm at the stairwell, another horizontal member would need to be added. The layout and construction details can be found in appendix S sheet S6. The columns would be connected to the walls via epoxy anchors on the second floor (Figure 6). This solution maintains the exterior look of the building. On the first floor the connection would be an anchorage design that penetrates the wall and connects to a plate on the opposite side (Figure 7). The columns would connect to concrete diaphragms using a steel plate and Simpson Titan screws. At wooden diaphragm connections, there would be a steel plate connected to a wooden block that then transfers load into the rafters. The strongbacks are designed as square hollow steel sections that extend four inches from the walls on the second floor and five inches from the walls on the first floor. This design conserves floor space and mimics the architectural partition wall column additions.

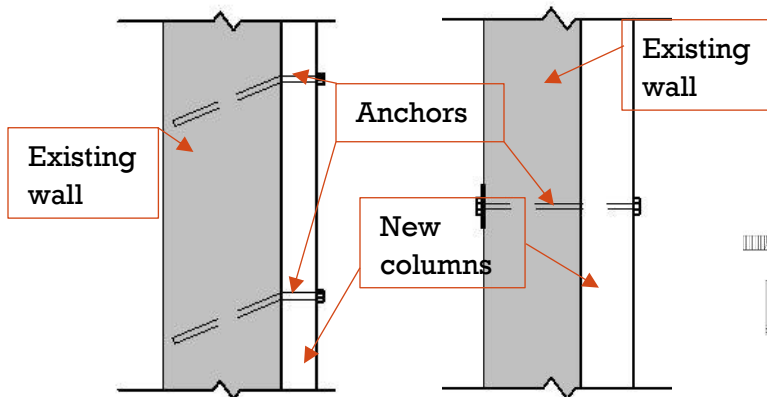

**FIGURE 6 –
EPOXY ANCHORS**

**FIGURE 7 –
PLATED ANCHOR**

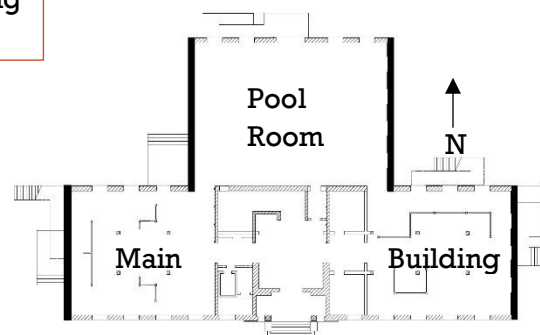

**FIGURE 8 – SHOTCRETE WALL LOCATIONS
(1ST FLOOR)**

To increase the capacity of the plan north/south walls for in plane shear load, we looked at the three common retrofits; shotcrete, brace frames and moment frames. After looking at the benefits of the three, we would recommend installing shotcrete walls to the locations called out as the black walls in figure 8. The shotcrete walls would be the best system to work around the windows and doors located frequently on these walls (see appendix S sheet S1 for a more detailed view). If a system of brace frames was used, the windows and doors would be blocked. Similarly, if a moment frame system was used, the URM walls would fail before the

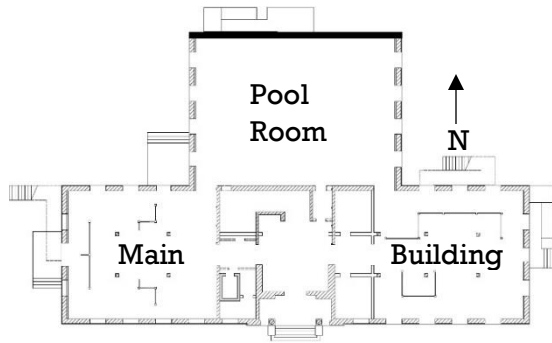

FIGURE 9 – WALL ANCHORAGE LOCATIONS (1ST FLOOR)

moment frame would feel any load. In the main building, the shotcrete walls would be connected to the concrete diaphragms with a steel angle and titan screws. This connection would be unobtrusive on the wall while transferring the in plane forces from the diaphragm to the ground. Similarly, this connection would be used in the poolroom to connect the shotcrete wall to the concrete floor. The connection to the roof timber diaphragm needed a different connection, because the in plane and out of plane forces would need to be transferred from the diaphragm. This was

accomplished using a Simpson Strong Tie anchor that has the ability to transfer both in plane and out of plane loads.

We recommend installing similar wall anchors to URM walls that connect to a wood diaphragm. This situation occurs at the roof level in the pool room and the roof level in the main building. The strongbacks and shotcrete walls would already have these connections if installed. Given that the shotcrete walls and strongbacks are installed, anchors are still required on the plan north wall of the pool room in Figure 9 labeled as darkened black lines. Anchorage details can be found in appendix S, sheets S7 and S8.

With the addition of the shotcrete walls in the pool room, we recommend connecting the pool room into the main building. Currently, the pool room walls are falling away from the main building (Figure 10). To solve this, a connection from the shotcrete walls into the URM of the main building is required. The connection would include rebar from the shotcrete through the URM, and then connected to the concrete diaphragm with the use of a metal plate and anchors to transfer the load into the diaphragm (see appendix S sheet S8).

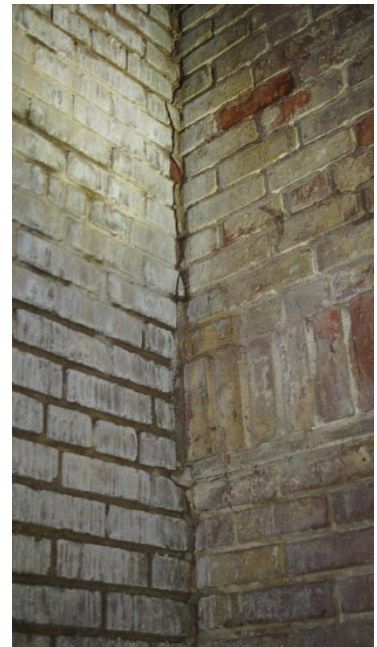

FIGURE 10 – SEPARATION AT WALL CONNECTION

Spira-lok anchor installation is recommended to tie back the veneer layer of the URM walls. These anchors are drilled through the veneer layer into the inner layers of the URM connecting the two. These anchors would be installed every four square feet as shown in the details in appendix S sheet S6.

We recommend adding a layer of sheathing to all wooden diaphragms. In addition, blocking between rafters will also need to be added to accommodate the seismic demands and the aspect ratio requirement for diaphragms in the NDS. The sheathing design details can be found in appendix S sheets S1 and S2.

Conclusion

The Building's Future

This proposal creates documentation for the Printery Foundation to use in their efforts to preserve, purchase and renovate the building. Our proposal offers suggestions for a new program, creating a multi-use building to meet the needs of the community including a community kitchen, café, educational workspace, gallery, event space, offices and gathering spaces. We have also provided suggestions for retrofitting the building to allow for life safety performance of both structural and non-structural elements. The elements suggested in the retrofit would minimize changes to the existing structure to ensure the character of the building remains intact.

Awareness

We see this proposal being used by the Foundation in upcoming events as a way to illustrate to the community how beneficial this building could be to the community if restored. It is our hope that by showing our interests, as students, that the community will also see the importance of restoring this historic part of the central coast into a useable building for every member of the Atascadero community.

References

Allan, Lon. "The Printery History." Atascadero Printery,
<http://www.atascaderoprintery.org/2017/02/03/printery-history-by-lon-allan/>.

Accessed 23 April 2017.

Figure 1a & 1b: Printery Foundation. n.a. 2016. n.a. Atascadero Printery.

<http://www.atascaderoprintery.org/2017/02/03/printery-history-by-lon-allan/>

Fountain, Matt. "Atascadero Printery taken off the auction block- for now." The Tribune

<http://www.sanluisobispo.com/news/local/article77097657.html>. Accessed 23 April 2017. Accessed 23 April 2017.

M & E

Appendix A

Architectural Drawings

EXISTING SITE PLAN

LOCATED IN A RESIDENTIAL AREA OF ATASCADERO, CALIFORNIA, THE PRINTERY BUILDING IS SET UPON A FAIRLY EMPTY LOT, SURROUNDED BY VARIOUS PARKS, A MIDDLE SCHOOL, AND CITY HALL. CURRENTLY, ON THE NORTHERN SIDE OF THE PRE-EXISTING BUILDING STANDS A GYMNASIUM AND KARATE STUDIO, ADD ONS TO THE HISTORIC CONSTRUCTION. THE GOAL OF THIS RETROFIT IS TO BRING BACK THE ORIGINAL SHELL OF THE BUILDING AND PLAN FOR FUTURE ADDITIONS TO THE SITE.

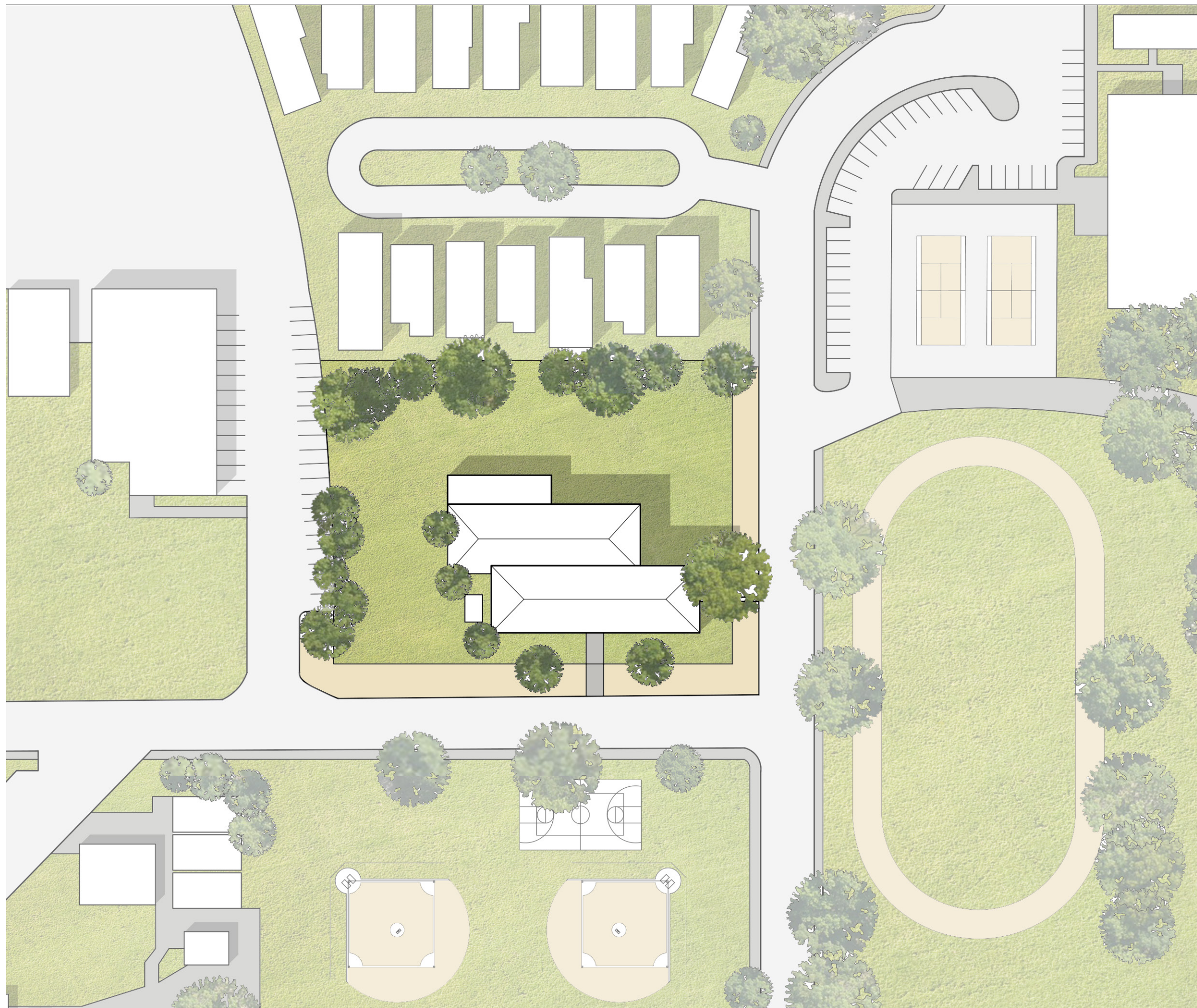

M&E

MARK LUZI
ELIZABETH TOWNSEND
CAL POLY | WINTER 17

ATASCADERO PRINTERY

ATASCADERO, CA 93422

DESIGN DEVELOPMENT
NOT FOR CONSTRUCTION

1" = 150' 

A1

DEMOLITION PLAN

THE GYMNASIUM AND KARATE STUDIO ADDITIONS, BOTH DAMAGED BEYOND REPAIR IN THE SAN SIMEON EARTHQUAKE, WILL BE REMOVED AND POTENTIALLY REPLACED BY A PERFORMING ARTS CENTER. THE WOOD FLOOR FROM THE GYM IS SALVAGEABLE AND WILL BE RESTORED AND REUSED IN THE PRINTERY.

- DEMOLISH
- PRESERVE

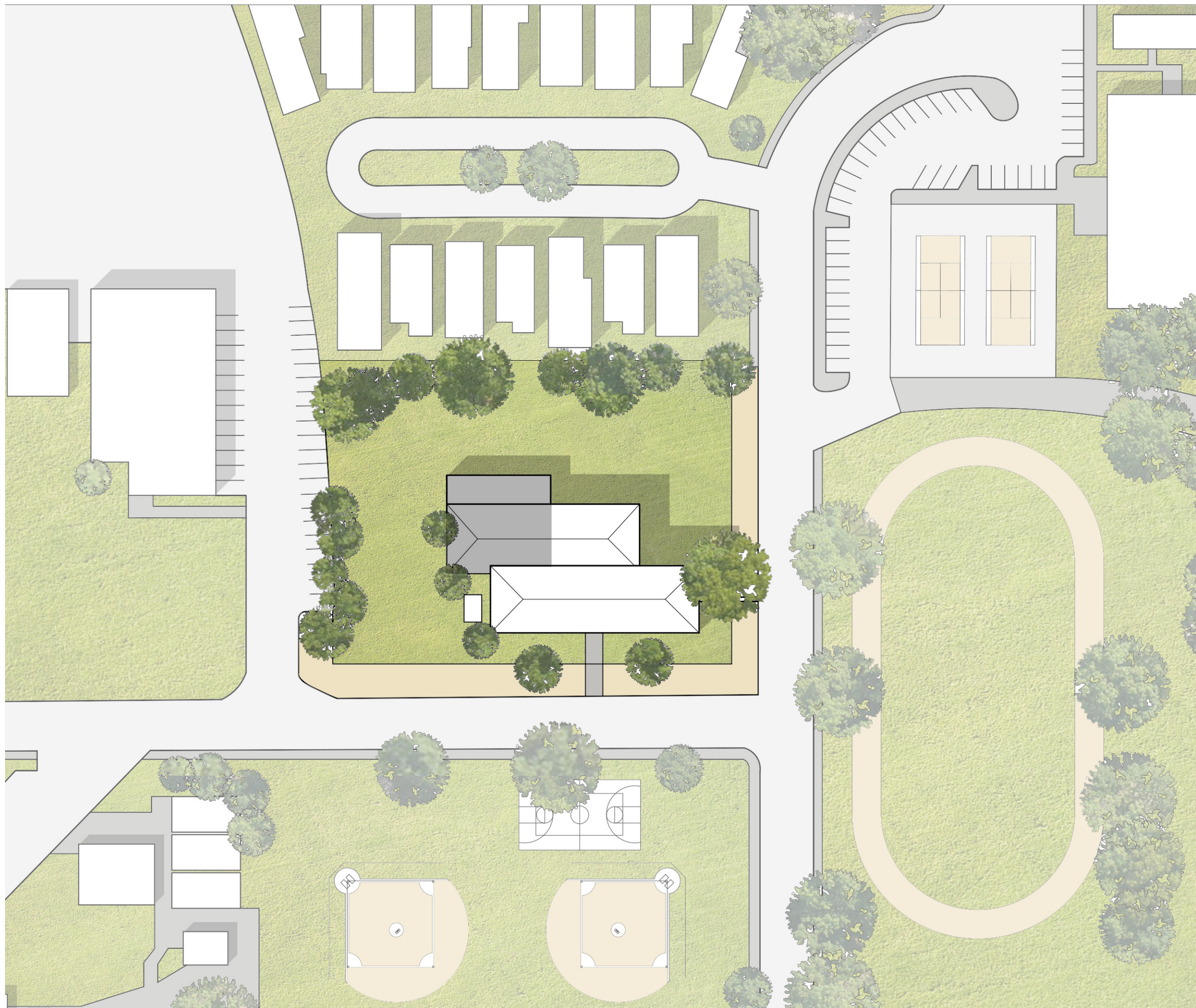

MARK LUZI
ELIZABETH TOWNSEND
CAL POLY | WINTER 17

ATASCADERO PRINTERY

ATASCADERO, CA 93422

DESIGN DEVELOPMENT
NOT FOR CONSTRUCTION

1" = 150'

A2

NEW SITE PLAN

THE ORIGINAL LAYOUT OF THE BUILDING WAS RESTORED, CREATING A SYMMETRICAL T SHAPE ON THE PROPERTY. IN ORDER TO ACCOMMODATE THE POTENTIAL NEW THEATER ON THE SITE, A PLACE HOLDER WAS ADDED TO THE NORTH SIDE OF THE BUILDING TO BE LATER DEVELOPED. USING THE REMAINDER OF THE SITE, ON STREET PARKING WAS ADDED TO THE FRONT OF THE BUILDING WITH A SMALLER SCALE LOT ADDED ON THE NORTH SIDE. KEEPING IN MIND THE COMMUNITY ASPECTS OF THE PROGRAM, COMMUNITY GARDENS, EVENT SPACES, AND BARBECUE PITS WERE ADDED TO THE LANDSCAPE.

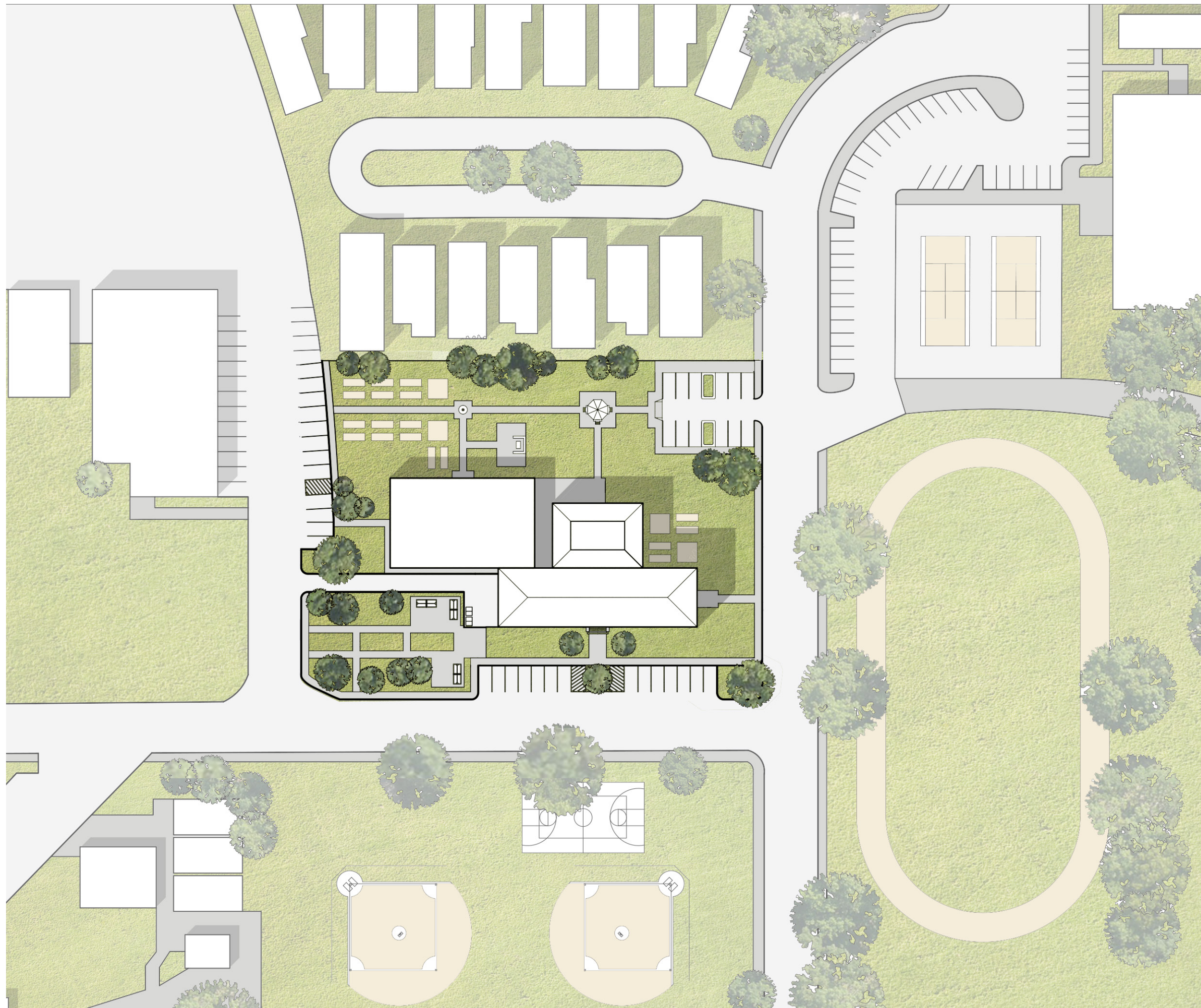

M&E

MARK LUZI
ELIZABETH TOWNSEND
CAL POLY | WINTER 17

ATASCADERO PRINTERY

ATASCADERO, CA 93422

DESIGN DEVELOPMENT

NOT FOR CONSTRUCTION

1" = 150'



A3

EXISTING SITE PLAN

1 | BASE - THE ORIGINAL BUILDING IS MADE UP OF A MASONRY EXTERIOR WALL WITH MINIMAL INTERIOR STRUCTURAL WALLS. THE OVERALL SCHEME RELIES ON AN OPEN FLOOR PLAN.

2 | SYMMETRY - WITH A STRONG EXISTING SYMMETRY, THE FIRST STEP IN THIS INTERVENTION WAS TO FURTHER THE SYMMETRICAL QUALITIES BY DESIGNING ADDITIONAL PERMANENT WALLS AROUND THE CENTRAL LOBBY CORE.

3 | PROGRAM - AN OVERALL PROGRAM WAS DEVISED WITH A FOCUS ON MULTIPURPOSE SPACES. THE MAJORITY OF THE PUBLIC SPACES ARE LOCATED ON THE FIRST FLOOR TO PROVIDE EASY ACCESS WHILE THE PRIVATE SPACES ARE LOCATED ON THE SECOND FLOOR TO ADDRESS SECURITY.

4 | GRID - EMPHASIZING THE SYMMETRY CREATED, A GRID WAS OVERLAID ONTO THE SPACE. THE GRID IS BASED ON THE WINDOW LAYOUT OF THE BUILDING AND PROVIDES AN OPPORTUNITY FOR FLEXIBILITY.

5 | MODULAR PARTITIONS - TO CREATE THE MOST SPACE WITH THE LEAST INTERVENTION, A MODULAR PARTITION SYSTEM IS USED THROUGHOUT THE BUILDING. THESE WALLS FEATURE INTERCHANGEABLE PARTS TO ALLOW ADAPTABILITY.

6 | EGRESS + ACCESSIBILITY - TO PRESERVE THE ENTRYWAY, THE APPROACH WAS LEFT UNTOUCHED. RAMPS WERE ADDED ON THE NORTH AND EAST SIDES FOR ADA. FIRE STAIRS WERE ADDED ALONG WITH AN ELEVATOR.



1 | BASE

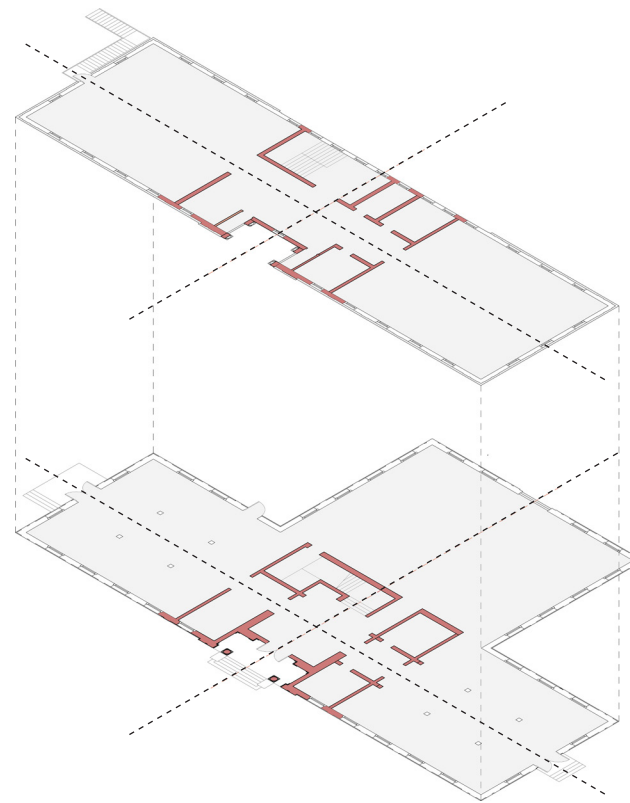

2 | SYMMETRY

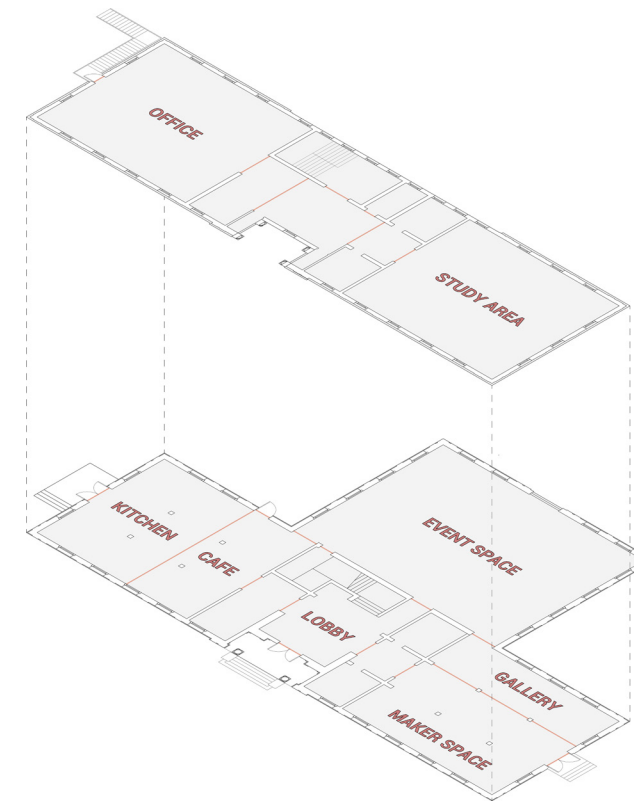

3 | PROGRAM

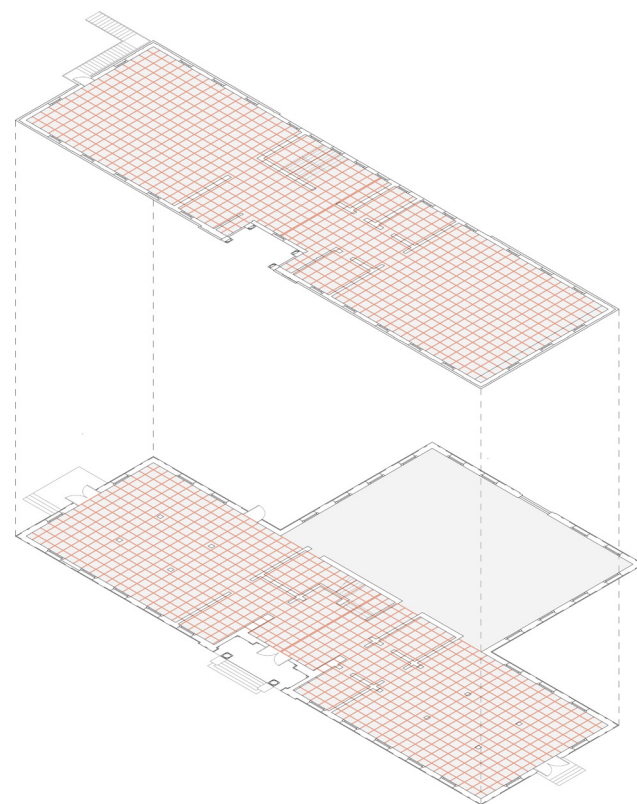

4 | GRID

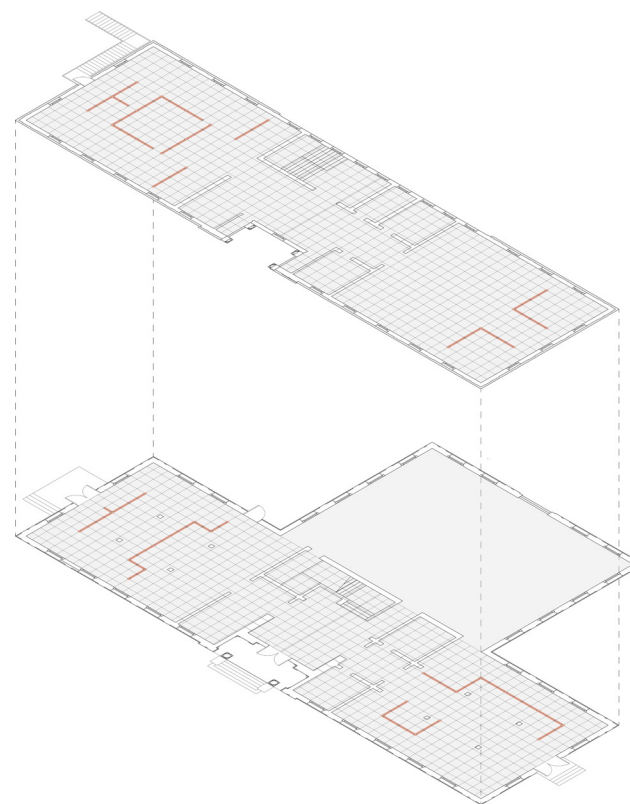

5 | MODULAR PARTITIONS

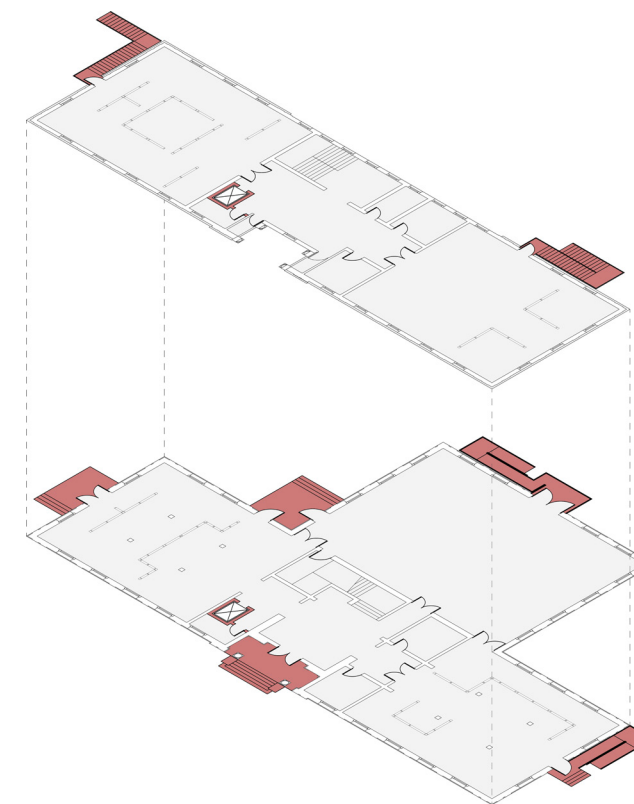

6 | ACCESSIBILITY + EGRESS

M&E

MARK LUZI
ELIZABETH TOWNSEND
CAL POLY | WINTER 17

ATASCADERO PRINTERY

ATASCADERO, CA 93422

DESIGN DEVELOPMENT
NOT FOR CONSTRUCTION

A4

FIRST FLOOR PLAN

- 1 | LOBBY
- 2 | KITCHEN
- 3 | CAFE
- 4 | EVENT SPACE
- 5 | GALLERY
- 6 | MAKER SPACE
- 7 | FUTURE THEATER

 EXISTING CONSTRUCTION
 NEW CONSTRUCTION

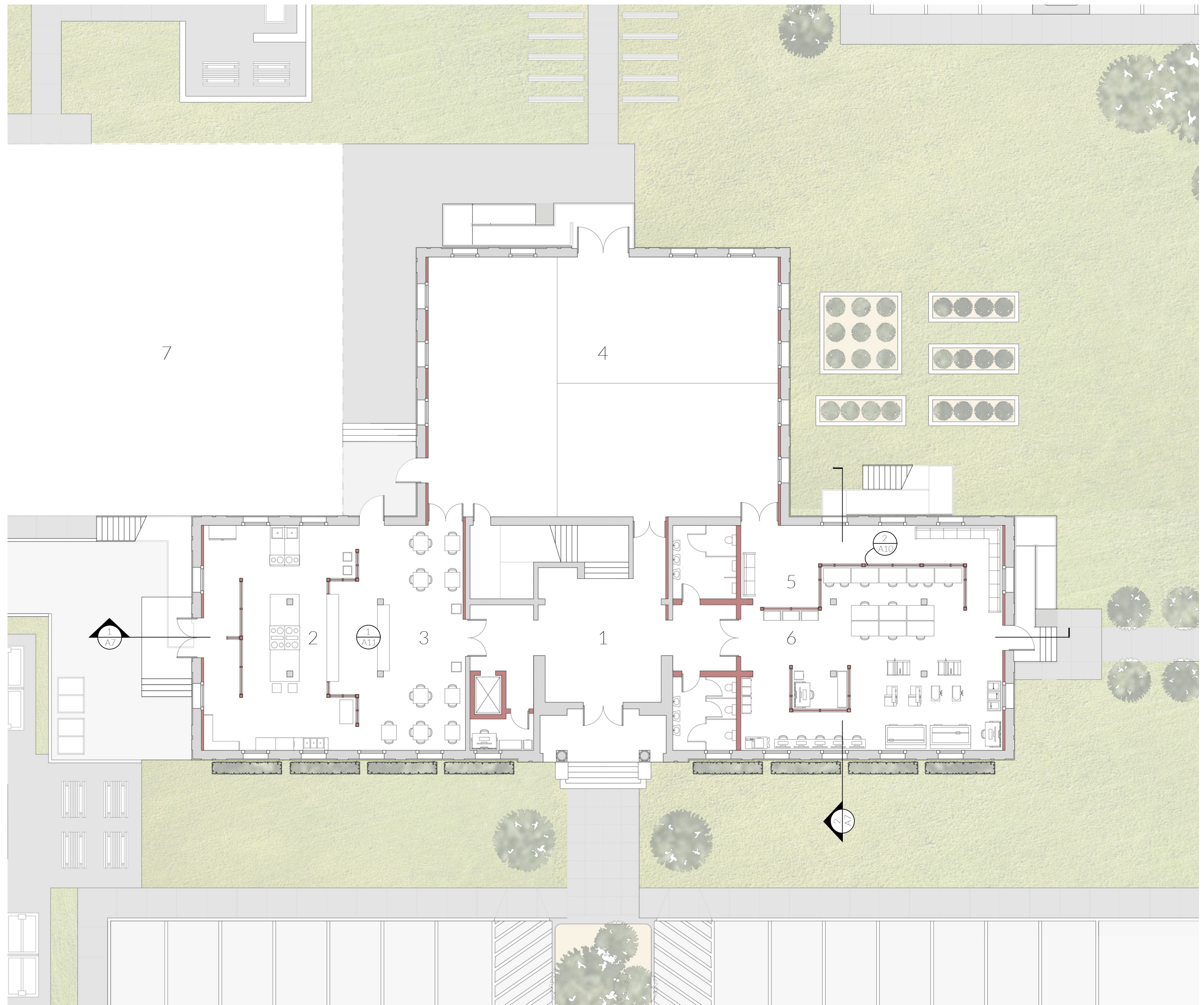

MARK LUZI
ELIZABETH TOWNSEND
CAL POLY | WINTER 17

ATASCADERO PRINTERY

ATASCADERO, CA 93422

DESIGN DEVELOPMENT
NOT FOR CONSTRUCTION

1" = 16' 

A5

**SECOND FLOOR
PLAN**

- 1 | COMMON SPACE
- 2 | OFFICE
- 3 | FORMAL MEETING AREA
- 4 | CASUAL MEETING AREA
- 5 | BREAK ROOM
- 6 | STORAGE
- 7 | GAME AREA

-  EXISTING CONSTRUCTION
-  NEW CONSTRUCTION

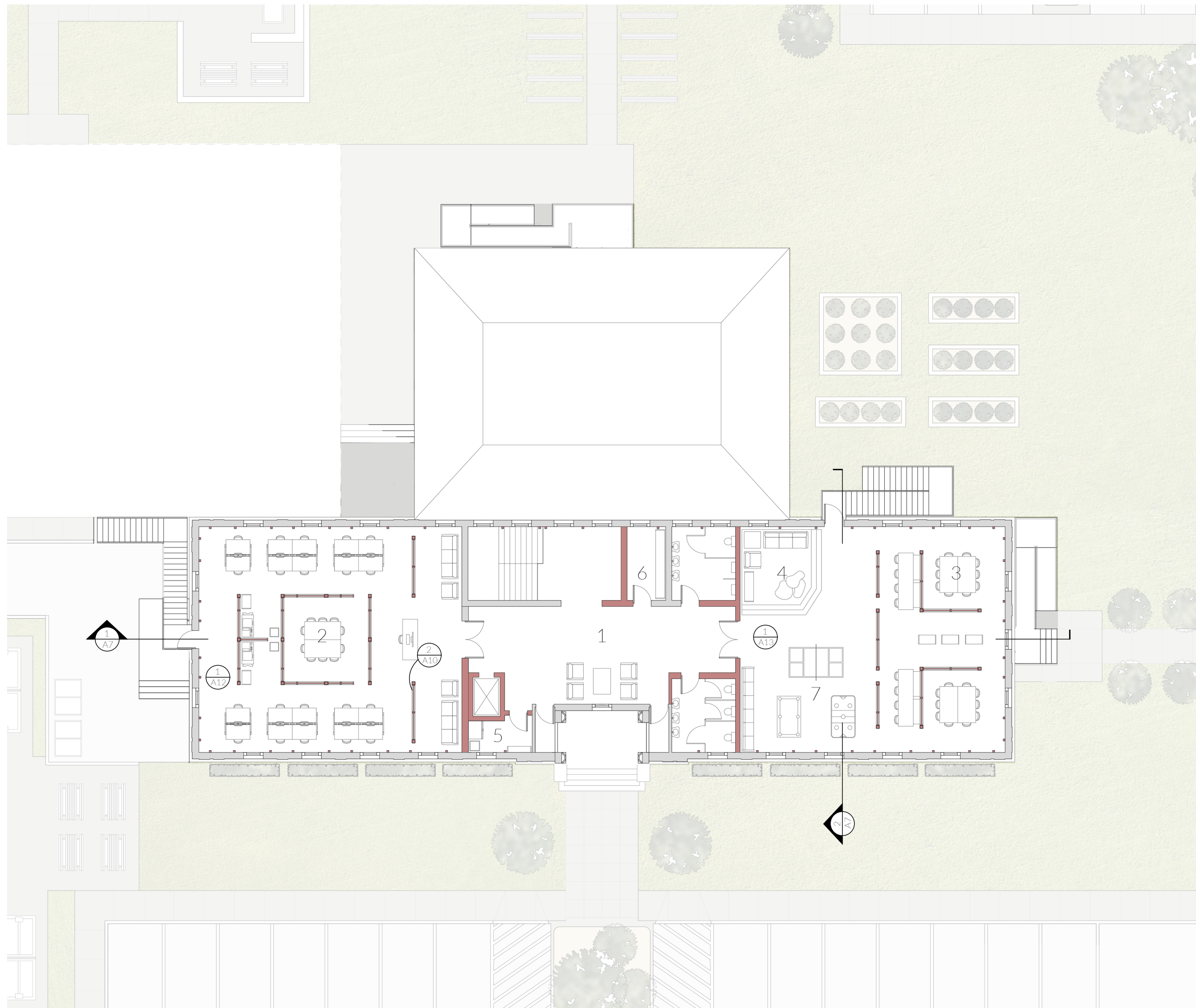

MARK LUZI
ELIZABETH TOWNSEND
CAL POLY | WINTER 17

ATASCADERO PRINTERY

ATASCADERO, CA 93422

DESIGN DEVELOPMENT
NOT FOR CONSTRUCTION

1" = 16' 

A6

1 | LONGITUDINAL SECTION

A CUT THROUGH ONE OF THE MAIN SYMMETRICAL AXES OF THE BUILDING. SPACES SHOWN INCLUDE THE OFFICE, COMMUNITY MEETING AREA, MAKERSPACE, LOBBY, CAFE AND KITCHEN.



2 | TRANSVERSE SECTION

A CUT THROUGH THE EAST END OF THE BUILDING. SPACES SHOWN INCLUDE THE COMMUNITY MEETING AREA AND MAKERSPACE, WITH THE EVENT SPACE SHOWN IN ELEVATION.



M&E

MARK LUZI
ELIZABETH TOWNSEND
CAL POLY | WINTER 17

ATASCADERO PRINTERY

ATASCADERO, CA 93422

DESIGN DEVELOPMENT

NOT FOR CONSTRUCTION

1" = 16'

1" = 8'

A7

MODULAR PARTITIONS

THE MAJORITY OF THE INTERIOR WALLS ARE CONSTRUCTED OF CUSTOM MODULAR PARTITIONS BASED OFF OF THE BUILDING'S GRID SO THAT THEY DO NOT TOUCH ANY EXISTING WALLS OR CEILINGS THUS PRESERVING THE ORIGINAL SHELL.

PARTITION SIZING

PARTITION DIMENSIONS ARE BASED ON THE GRID OVERLAID ON THE EXISTING BUILDING. FRAMES ARE DIMENSIONED TO FIT BETWEEN GRIDLINES WITH OCCASIONAL ANCHORING BARS FOR STABILITY, MAKING FOR EASY SET UP AND INTERCHANGEABILITY.

MODULAR OPTIONS

IN ORDER TO CREATE A FLEXIBLE AND DYNAMIC PARTITION SYSTEM, THE DESIGN OF EACH FRAME AND INFILL PIECE IS MODULAR. THE FRAMES ARE DESIGNED TO CREATE A VARIETY OF POSSIBLE COMBINATIONS, ALLOWING THE USER TO CONSTRUCT THE PARTITION BASED ON PROGRAMMATIC NEEDS. SIX UNIQUE INFILL PIECES ARE OFFERED TO PROVIDE ATTACHMENT MODULES, PRIVACY, AND OVERALL ADAPTABILITY.

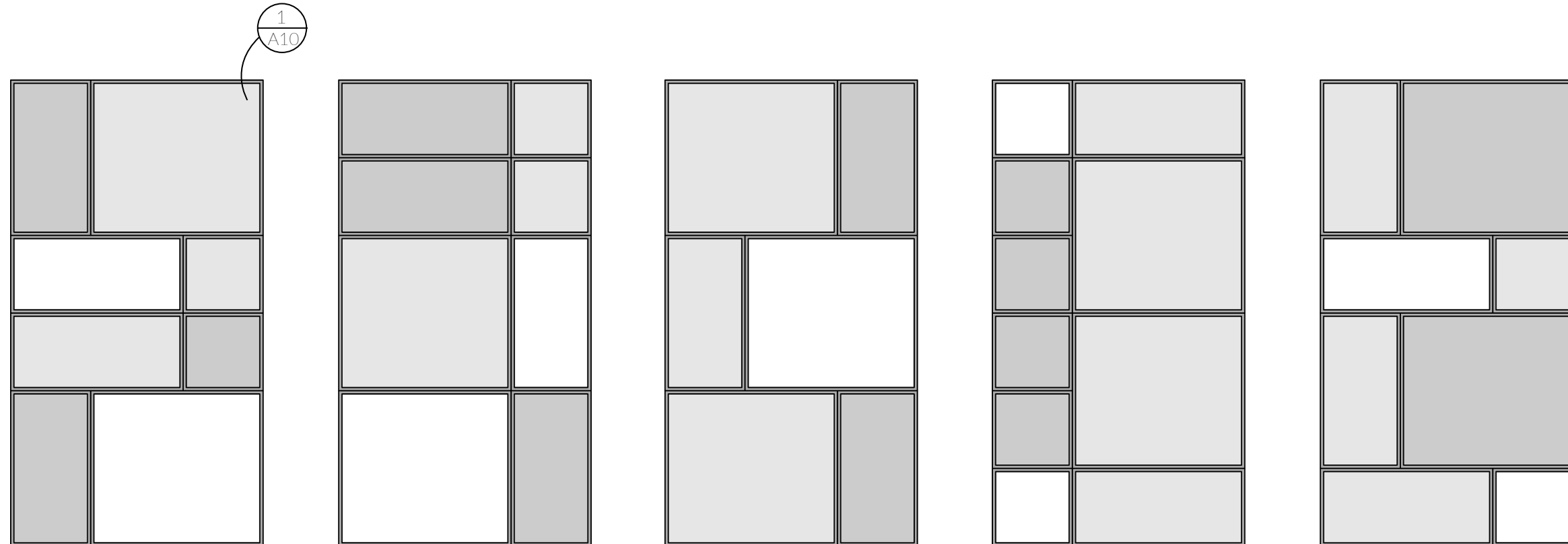
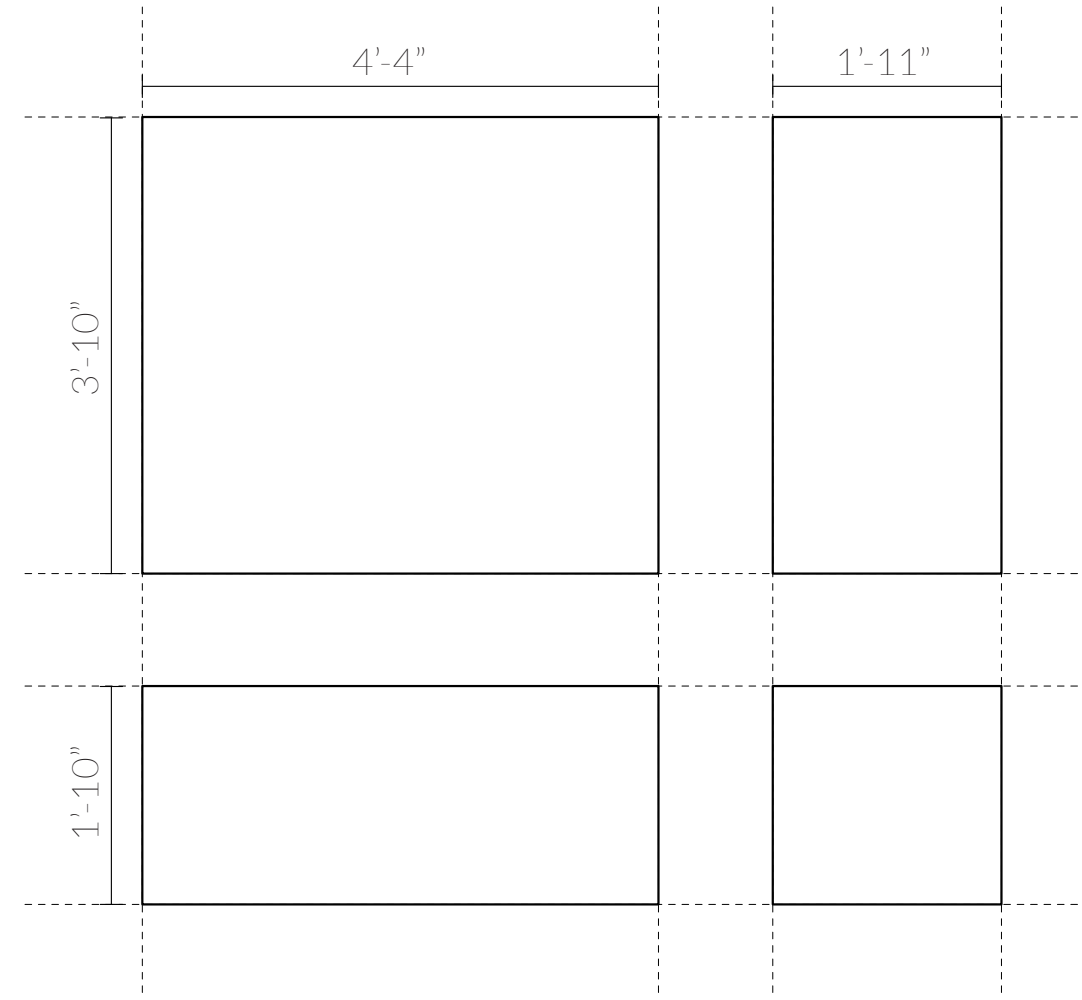
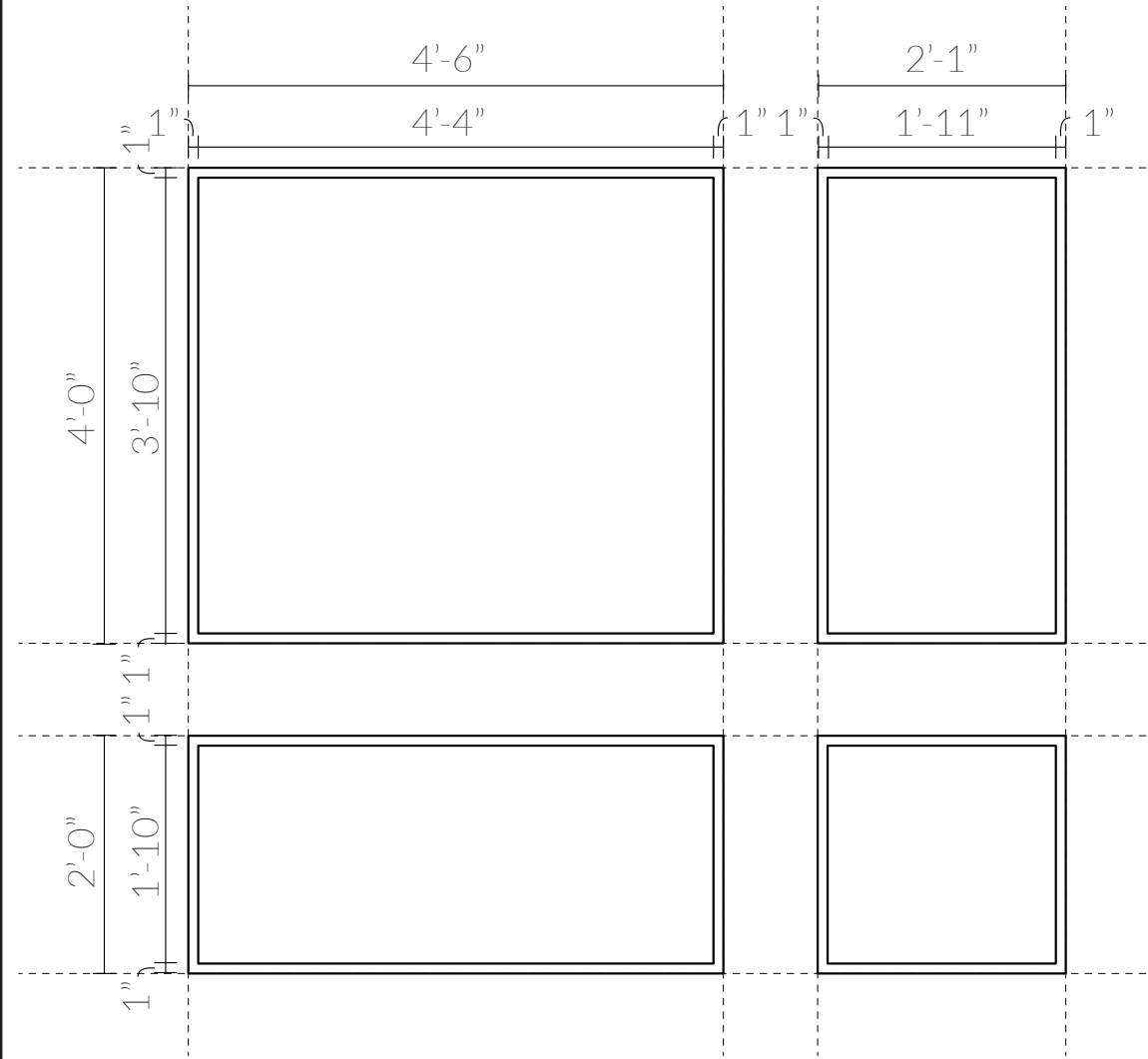

MARK LUZI
ELIZABETH TOWNSEND
CAL POLY | WINTER 17

ATASCADERO PRINTERY

ATASCADERO, CA 93422

DESIGN DEVELOPMENT
NOT FOR CONSTRUCTION

A8

1 | PARTITION ASSEMBLY

THE PARTITIONS ARE DESIGNED TO CONNECT TOGETHER WITH SIMPLE NUT AND BOLT CONNECTIONS, MAKING EACH PARTITION EASILY REARRANGEABLE. EACH FRAME IS EASILY CUSTOMIZABLE AS WELL, WITH THE INFILL PANELS HELD IN BY SIMPLE TO REMOVE BRACKETS THAT ARE DESIGNED TO ADAPT TO ANY NUMBER OR THICKNESS OF PANELS.

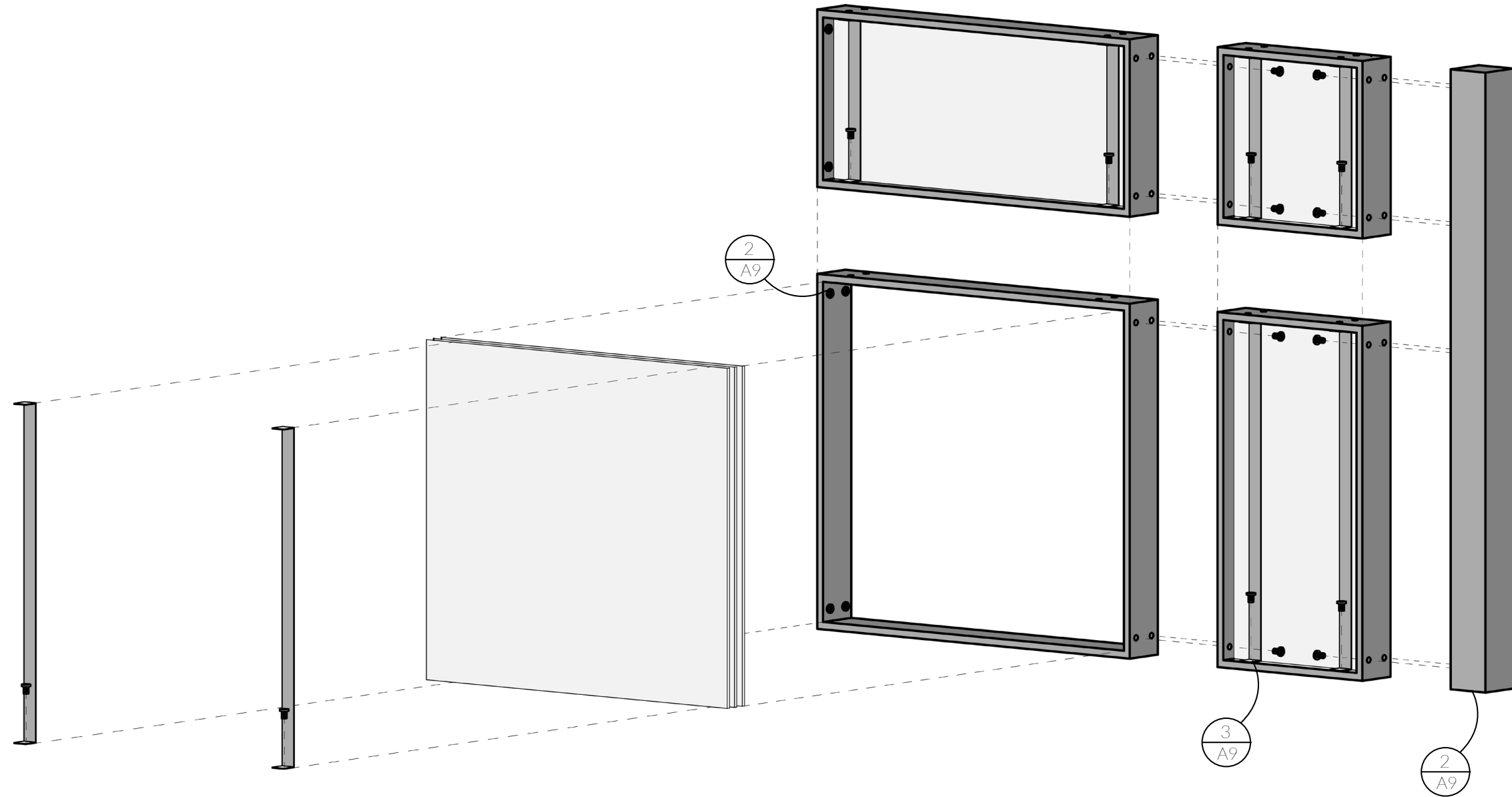

CONNECTION DETAILS

- 2 | ANCHOR BAR TO FLOOR
- 3 | BRACKET TO FRAME
- 4 | FRAME TO FRAME

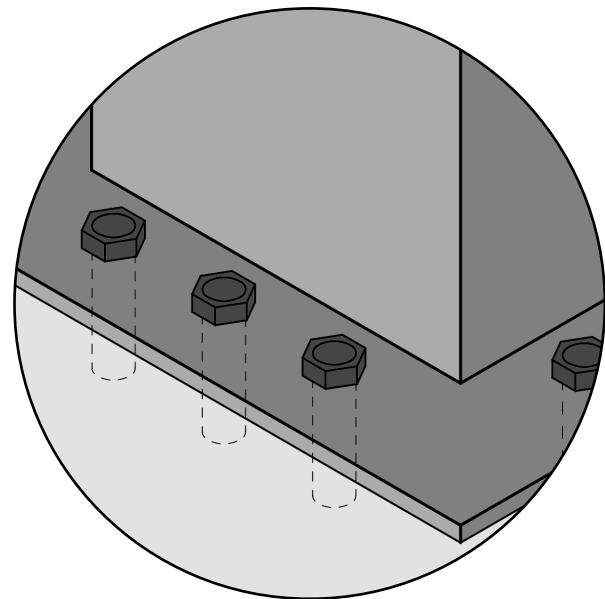

ANCHOR BAR TO FLOOR

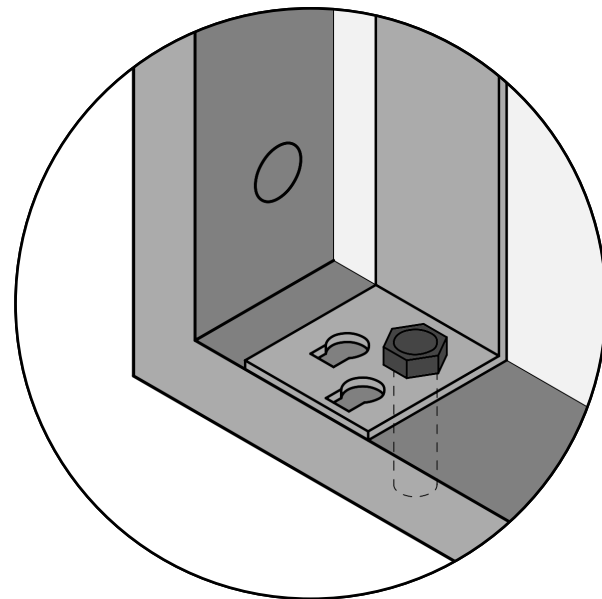

BRACKET TO FRAME

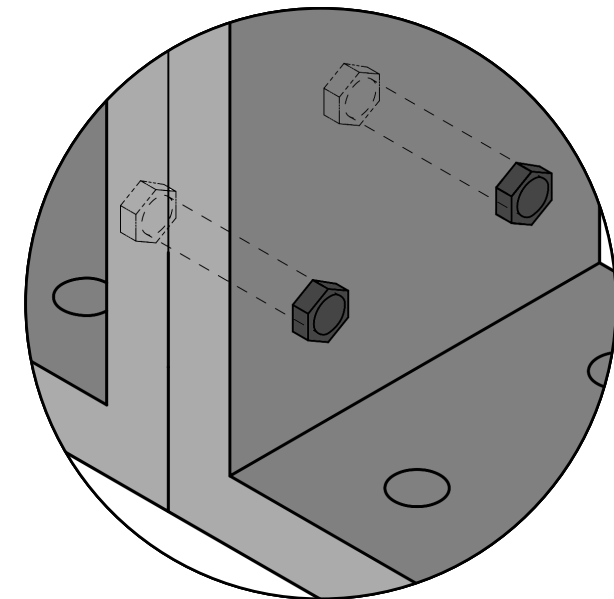

FRAME TO FRAME



MARK LUZI
ELIZABETH TOWNSEND
CAL POLY | WINTER 17

ATASCADERO PRINTERY

ATASCADERO, CA 93422

DESIGN DEVELOPMENT
NOT FOR CONSTRUCTION

A9

1 | MATERIALITY

THE INFILL PANELS ARE AVAILABLE IN SIX MATERIALS AND PATTERNS TO ADD ANOTHER LEVEL OF USABILITY TO EACH PARTITION. EACH FRAME HAS THE ABILITY TO HOLD THREE LAYERS OF INFILL PANELS FOR PROGRAM OR PRIVACY CUSTOMIZATION.



OAK WOOD



OAK WOOD LATTICE



PLEXIGLASS

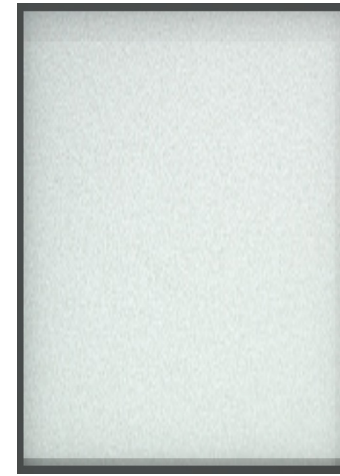

FROSTED PLEXIGLASS

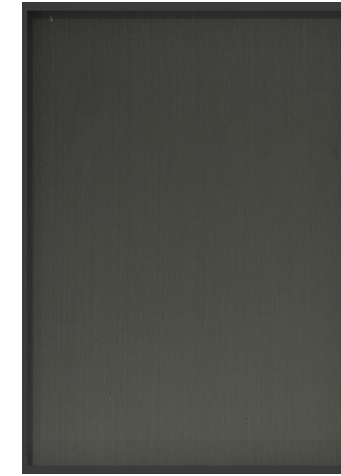

ALUMINUM



ALUMINUM LATTICE

2 | VISUALIZATION

RENDER OF A SAMPLE PARTITION WITH MATERIALITY.



M&E

MARK LUZI
ELIZABETH TOWNSEND
CAL POLY | WINTER 17

ATASCADERO PRINTERY

ATASCADERO, CA 93422

DESIGN DEVELOPMENT

NOT FOR CONSTRUCTION

A10



M&E

MARK LUZI
ELIZABETH TOWNSEND
CAL POLY | WINTER 17

ATASCADERO PRINTERY

ATASCADERO, CA 93422

DESIGN DEVELOPMENT
NOT FOR CONSTRUCTION

A11



MARK LUZI
ELIZABETH TOWNSEND
CAL POLY | WINTER 17

ATASCADERO PRINTERY

ATASCADERO, CA 93422

DESIGN DEVELOPMENT
NOT FOR CONSTRUCTION

A12



M&E

MARK LUZI
ELIZABETH TOWNSEND
CAL POLY | WINTER 17

ATASCADERO PRINTERY

ATASCADERO, CA 93422

DESIGN DEVELOPMENT
NOT FOR CONSTRUCTION

A13

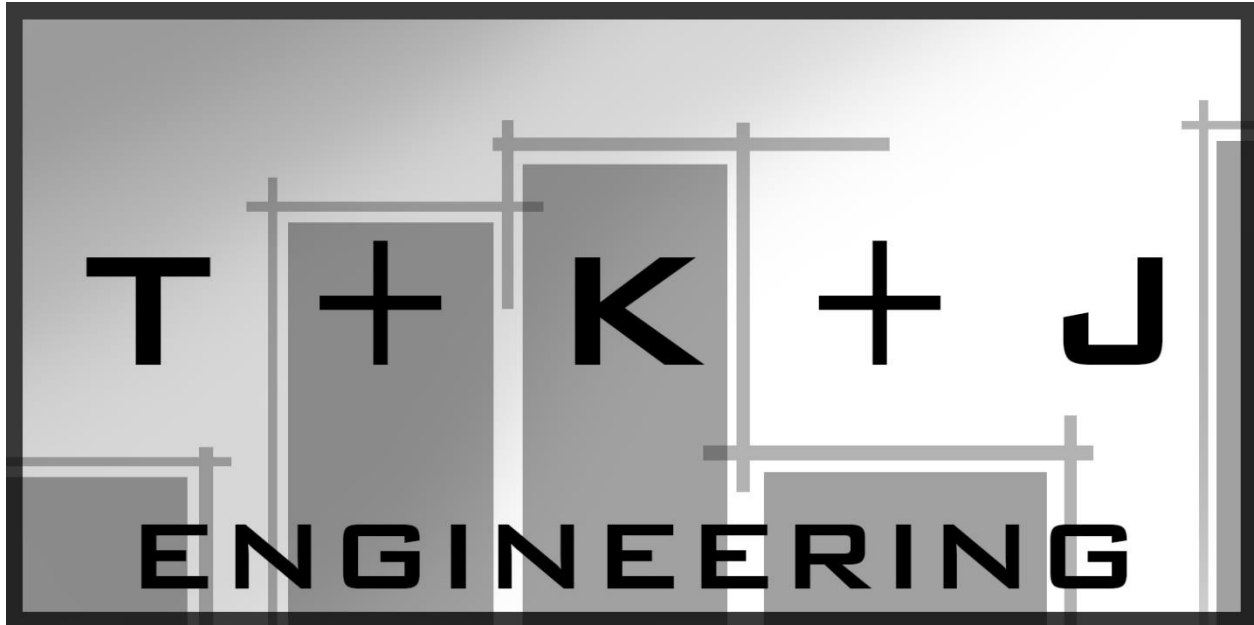

Appendix S

Structural Drawings

GENERAL NOTES

GENERAL CRITERIA

- ALL MATERIALS, WORKMANSHIP, DESIGN, AND CONSTRUCTION SHALL CONFORM TO THE DRAWINGS, AND THE INTERNATIONAL BUILDING CODE (2015 EDITION)
- THIS STRUCTURE DOES NOT CONFORM TO EARTHQUAKE CODE REQUIREMENTS. IT HAS BEEN REINFORCED IN ACCORDANCE WITH ASCE 41-13 AND IS WITHIN THE CURRENT PRACTICE FOR THE RENOVATION OF EXISTING BUILDINGS OF THIS AGE AND TYPE OF CONSTRUCTION.
- STRUCTURAL DRAWINGS SHALL BE USED IN CONJUNCTION WITH ARCHITECTURAL DRAWINGS. CONTRACTOR SHALL VERIFY DIMENSIONS AND CONDITIONS FOR COMPATIBILITY AND SHALL NOTIFY ARCHITECT OF ANY DISCREPANCIES PRIOR TO CONSTRUCTION.
- CONTRACTOR SHALL VERIFY ALL EXISTING DIMENSIONS, MEMBER SIZES, AND CONDITIONS PRIOR TO COMMENCING ANY WORK. ALL DIMENSIONS OF EXISTING CONSTRUCTION SHOWN ON THE DRAWINGS ARE INTENDED AS GUIDELINES ONLY AND MUST BE VERIFIED.
- CONTRACTOR SHALL BE RESPONSIBLE FOR ALL SAFETY PRECAUTIONS AND THE METHODS, TECHNIQUES, SEQUENCES, OR PROCEDURES REQUIRED TO PERFORM HIS/HER WORK. THE STRUCTURAL ENGINEER HAS NO OVERALL SUPERVISORY AUTHORITY OR ACTUAL AND/OR DIRECT RESPONSIBILITY FOR THE SPECIFIC WORKING CONDITIONS AT THE SITE AND/OR FOR ANY HAZARDS RESULTING FROM THE ACTIONS OF ANY TRADE CONTRACTOR. THE STRUCTURAL ENGINEER HAS NO DUTY TO INSPECT, SUPERVISE, NOTE, CORRECT, OR REPORT ANY HEALTH OR SAFETY DEFICIENCIES OF THE OWNER, CONTRACTORS, OR OTHER ENTITIES OR PERSONS AT THE PROJECT SITE.

CONCRETE

- CONCRETE SHALL ATTAIN A 28-DAY STRENGTH OF $f_c = 3,000$ PSI AND MIX SHALL CONTAIN NOT LESS THAN 5-1/2 SACKS OF CEMENT PER CUBIC YARD AND SHALL BE PROPORTIONED TO PRODUCE A SLUMP OF 5" OR LESS.

REINFORCING STEEL

- ALL REINFORCING STEEL SHALL BE GRADE 60, $f_y = 60,000$ PSI.
- REINFORCING COMPLYING WITH ASTM A615 (S1) MAY BE WELDED ONLY IF MATERIAL PROPERTY REPORTS INDICATING CONFORMANCE WITH WELDING SPECIFIED IN A.W.S. D1.4 ARE SUBMITTED.
- LAP ALL CONTINUOUS REINFORCEMENT #5 AND SMALLER 40 BAR DIAMETERS OR 2'-0" MINIMUM, PROVIDE CORNER BARS AT ALL WALL AND FOOTING INTERSECTIONS. LAP CORNER BARS #5 AND SMALLER 40 BAR DIAMETERS OR 2'-0" MINIMUM. LAPS OF LARGER BARS SHALL BE MADE IN ACCORDANCE WITH ACI 318-02, CLASS B.
- COVER FOR WALLS (INTERIOR FACE) SHALL BE 3/4" MINIMUM.

STRUCTURAL STEEL

- ALL STEEL PLATES SHALL BE A36.
- ALL STEEL ROLLED MEMBERS SHALL BE A992 GRADE 50.
- ANCHOR BOLTS AND CONNECTION BOLTS SHALL CONFORM TO ASTM A307.
- ALL WELDING SHALL BE IN CONFORMANCE WITH A.I.S.C. AND A.W.S. STANDARDS AND SHALL BE PERFORMED BY W.A.B.O. CERTIFIED WELDERS USING E70 XX ELECTRODES. ONLY PREQUALIFIED WELDS (AS DEFINED BY A.W.S.) SHALL BE USED. WELDING OF GRADE 60 REINFORCING BARS (IF REQUIRED) SHALL BE PERFORMED USING LOW HYDROGEN ELECTRODES.

WOOD

- FRAMING LUMBER SHALL BE KILN DRIED OR MC-19, AND GRADED AND MARKED IN CONFORMANCE WITH W.C.L.I.B. STANDARD GRADING RULES FOR WEST COAST LUMBER NO. 17, LATEST EDITION.
- ALL NEW WOOD SHALL BE DF-L No. 1.
- TIMBER CONNECTORS CALLED OUT BY LETTERS AND NUMBERS SHALL BE 'STRONG-TIE' BY SIMPSON COMPANY, AS SPECIFIED IN THEIR CATALOG. PROVIDE NUMBER AND SIZE OF FASTENERS AS SPECIFIED BY MANUFACTURER. CONNECTORS SHALL BE INSTALLED IN ACCORDANCE WITH THE MANUFACTURER'S RECOMMENDATIONS.
- UNLESS NOTED OTHERWISE, ALL NAILS SHALL BE COMMON.





DESIGN CRITERIA

GRAVITY LOADS	
POOL ROOF DEAD LOAD:	27 psf
MAIN ROOF DEAD LOAD:	27 psf
MAIN FLOOR DEAD LOAD:	105 psf
SEISMIC INFORMATION	
SOIL CLASSIFICATION:	D
RISK CATEGORY:	II
SITE LATITUDE:	35.491
SITE LONGITUDE:	-120.663
FROM USGS:	$S_g = 0.452$ g $S_1 = 0.169$ g $F_v = 2.126$ $F_A = 1.438$ $S_{XS} = 0.651$ g $S_{X1} = 0.358$ g
SEISMIC DESIGN CATEGORY:	D
FOR URM:	R = 1.5
FOR SHOTCRETE:	R = 5
IMPORTANCE FACTOR:	$I_b = 1.0$

ABBREVIATIONS

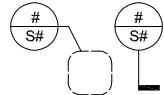
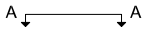
ANCHOR BOLT	AB
CONCRETE	CONC.
DIAMETER	DIAM
EXISTING	(E)
FLOOR	FLR
MAXIMUM	MAX.
MINIMUM	MIN.
MILLIMETERS	MM
NEW	(N)
ON CENTER	O.C.
THICK	THK
TYPICAL	TYP
UNREINFORCED MASONRY	URM
WITH	w/

SYMBOL LEGEND

DETAIL REFERENCE		SECTION	
BREAK LINE		SPAN	
(N) SHEATHING		(N) STRONGBACK	

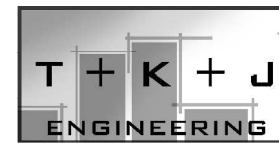

TYLER PIZARRO
KAYLEE EFSTATHIU
JAMI HAHN
CAL POLY
WINTER 2017

ATASCADERO PRINTERY

ATASCADERO, CA 93422

GENERAL NOTES

SCALE: N/A

S0

ATASCADERO PRINTERY

ATASCADERO, CA 93422

FIRST FLOOR
PLAN

SCALE: 1/16" = 1'-0"

S1

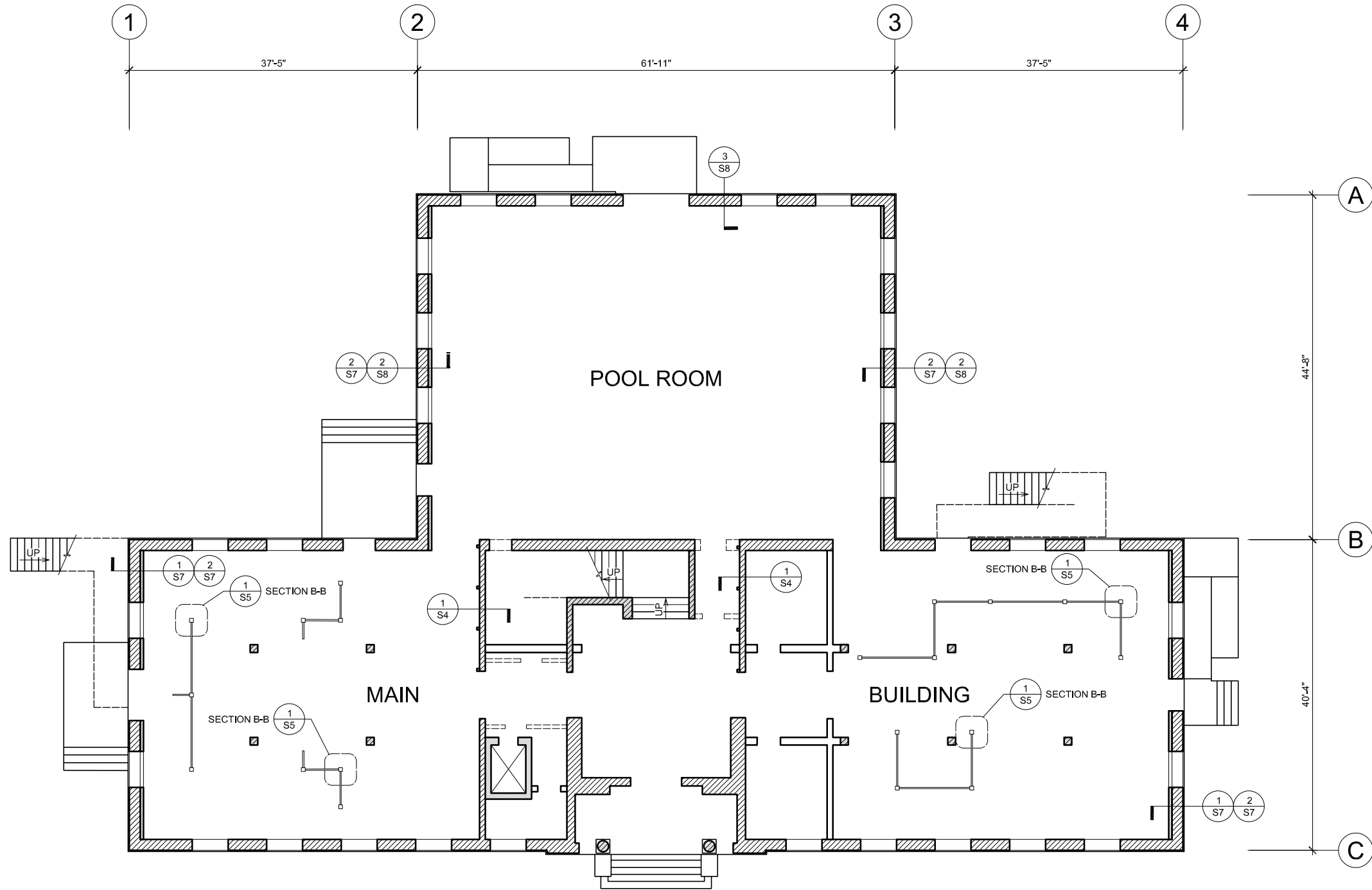

FIRST FLOOR PLAN

SCALE: 1/16" = 1'-0"

FIRST FLOOR NOTES: (#)

1. ALL STRONGBACKS SHALL BE SPACED AT 6'-0" o.c. MAX. AND HAVE A MIN. CLEAR DISTANCE OF 6" FROM ANY ADJACENT OPENING.
2. NEW 5" THICK SHOTCRETE WALLS SHALL HAVE A CURTAIN OF #4 BARS @ 12" o.c. EACH WAY
3. FOR ALL EXTERIOR WALLS SEE DETAIL 1/S6 FOR VENEER ATTACHMENT.

WALL LEGEND	
(N) TIMBER	CONC. BEAM BELOW
(E) URM	(E) TIMBER
(N) SHOTCRETE	URM BELOW
(E) CONC.	SHOTCRETE BELOW
	TO BE DEMOLISHED

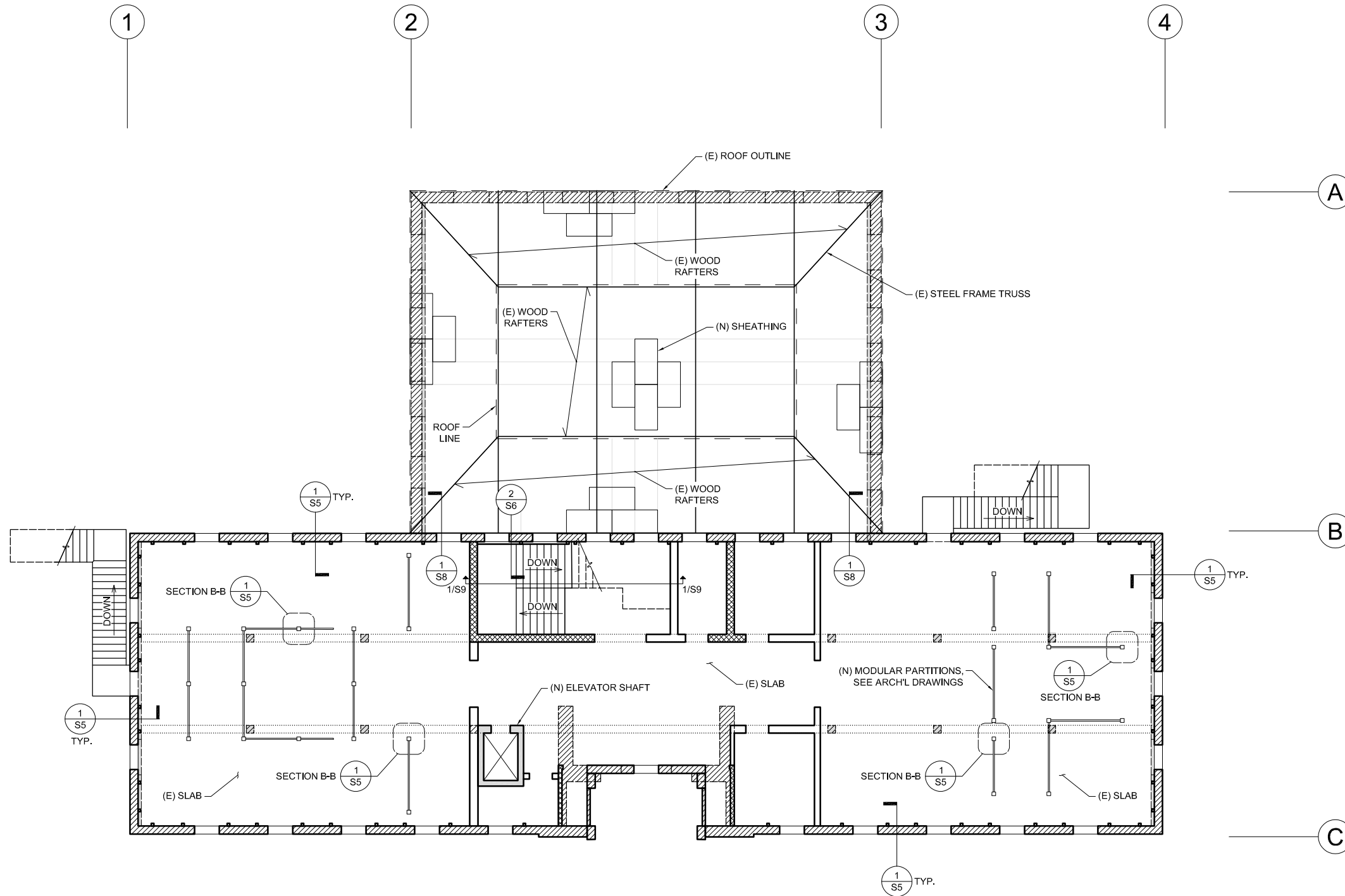

SECOND FLOOR AND LOWER ROOF FRAMING PLAN

SCALE: 1/16" = 1'-0"

SECOND FLOOR AND PARTIAL ROOF FRAMING NOTES: (#)

1. ALL STRONGBACKS SHALL BE SPACED AT 6'-0" o.c. MAX. AND HAVE A MIN. CLEAR DISTANCE OF 6" FROM ANY ADJACENT OPENING.
A. SEE PLAN FOR APPROXIMATE LOCATIONS.
2. ALL LOWER ROOF SHEATHING SHALL BE BLOCKED 3/8" w/ 8d AT 6/6/12 NAILING.
3. FILL IN FLOOR SLAB CRACKS WITH SIMPSON CRACK-PAC INJECTION EPOXY PER MANUFACTURER INSTALLATION REQUIREMENTS.
4. FOR ALL EXTERIOR WALLS SEE DETAIL 1/S6 FOR VENEER ATTACHMENT.

WALL LEGEND	



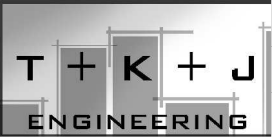

TYLER PIZARRO
KAYLEE EFSTATHIU
JAMI HAHN
CAL POLY
WINTER 2017

ATASCADERO PRINTERY

ATASCADERO, CA 93422

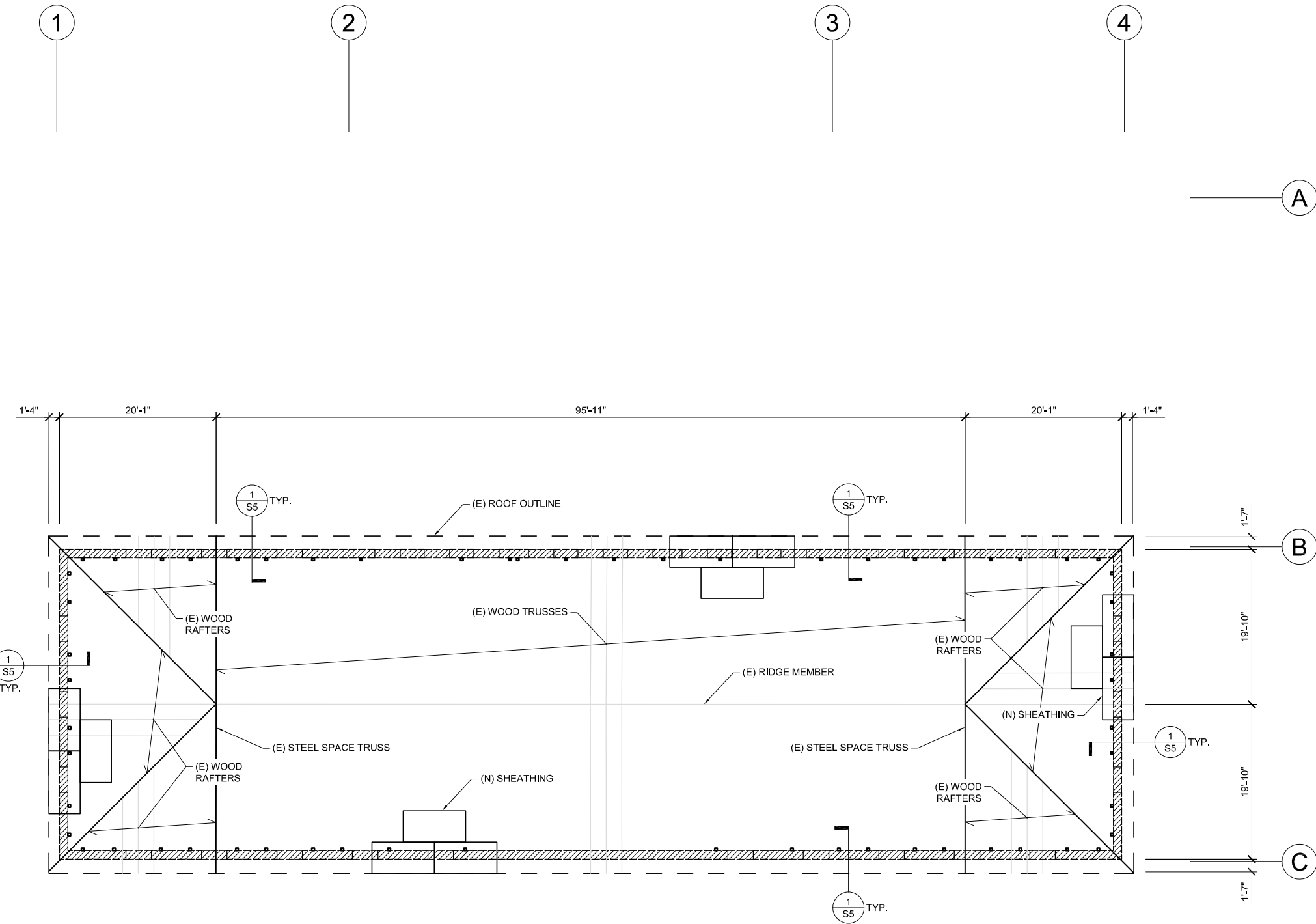

ROOF FRAMING PLAN

SCALE: 1/16" = 1'-0"

ROOF FRAMING NOTES: (#)

- ALL SHEATHING SHALL BE BLOCKED 1 9/32" w/ 10d. SEE SHEATHING KEY PLAN FOR NAILING ZONES.
 - ZONE (A) SHALL BE 2 LINES OF FASTENERS AT 2 5/8/6/12 w 4x8 MEMBERS SISTERED ON ALL RAFTERS.
 - ZONE (B) SHALL BE 2 LINES OF FASTENERS AT 4/4/12 w 4x8 MEMBERS SISTERED ON ALL RAFTERS.
 - ZONE (C) SHALL BE AT 6/3/12.

WALL LEGEND	
	(N) TIMBER
	(E) URM
	(N) SHOTCRETE
	(E) CONC.
	CONC. BEAM BELOW
	(E) TIMBER
	URM BELOW
	SHOTCRETE BELOW
	TO BE DEMOLISHED



SHEATHING KEY PLAN

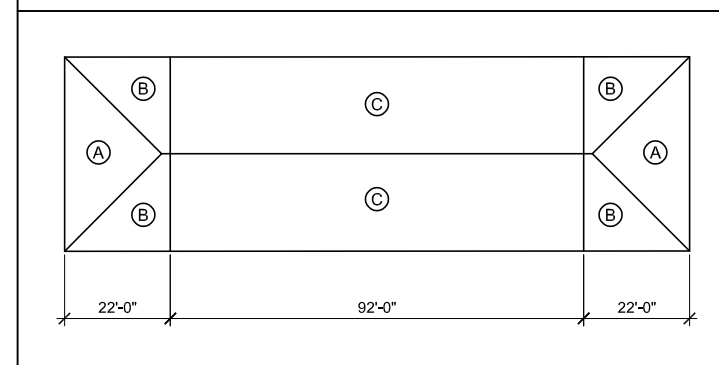

ROOF FRAMING PLAN

SCALE: 1/16" = 1'-0"

S3

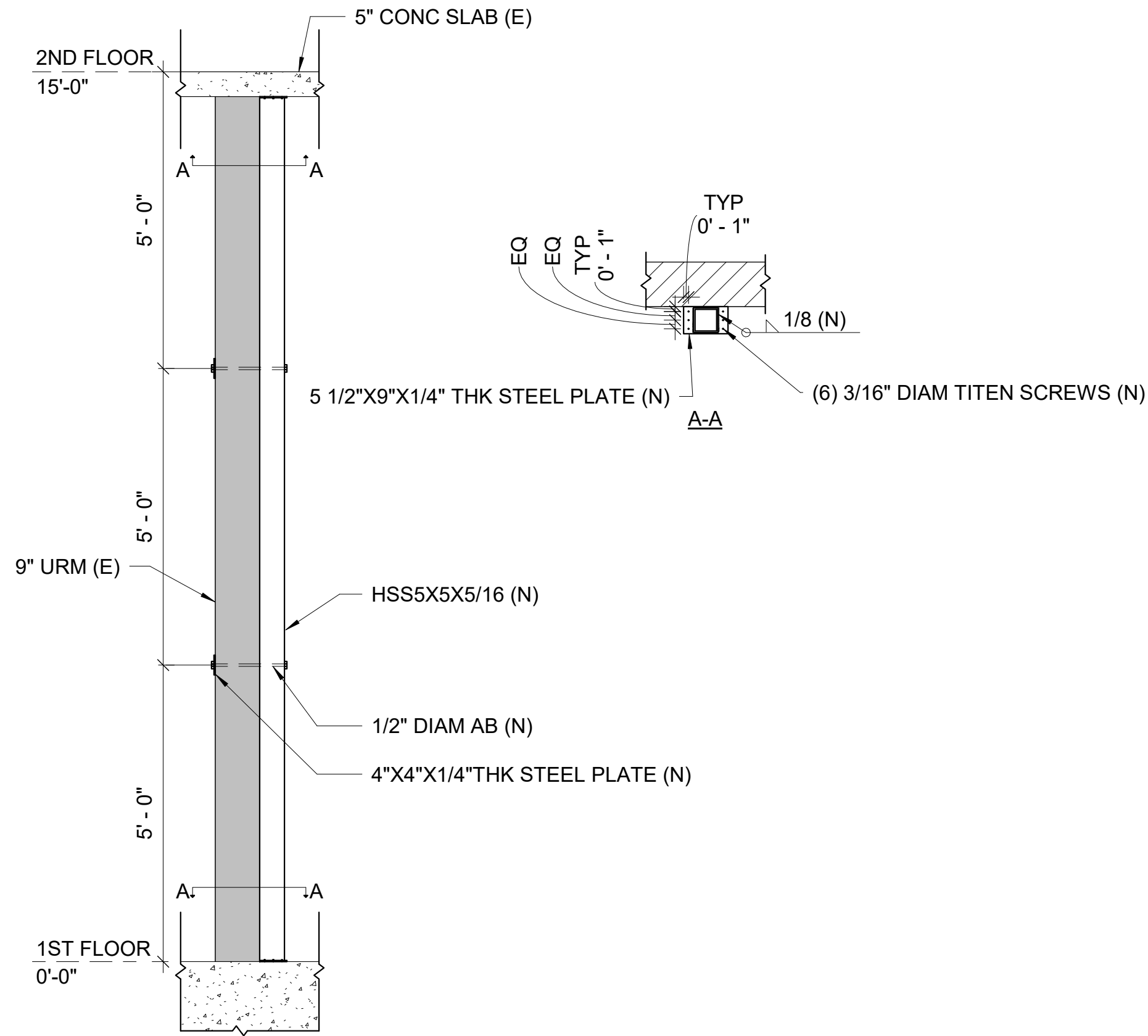

1 TYP STRONGBACK ELEVATION @ 1ST FLR
1/2" = 1'-0"

ATASCADERO PRINTERY

ATASCADERO, CA 93422

DETAILS

SCALE: 1/2" = 1'-0"

S4

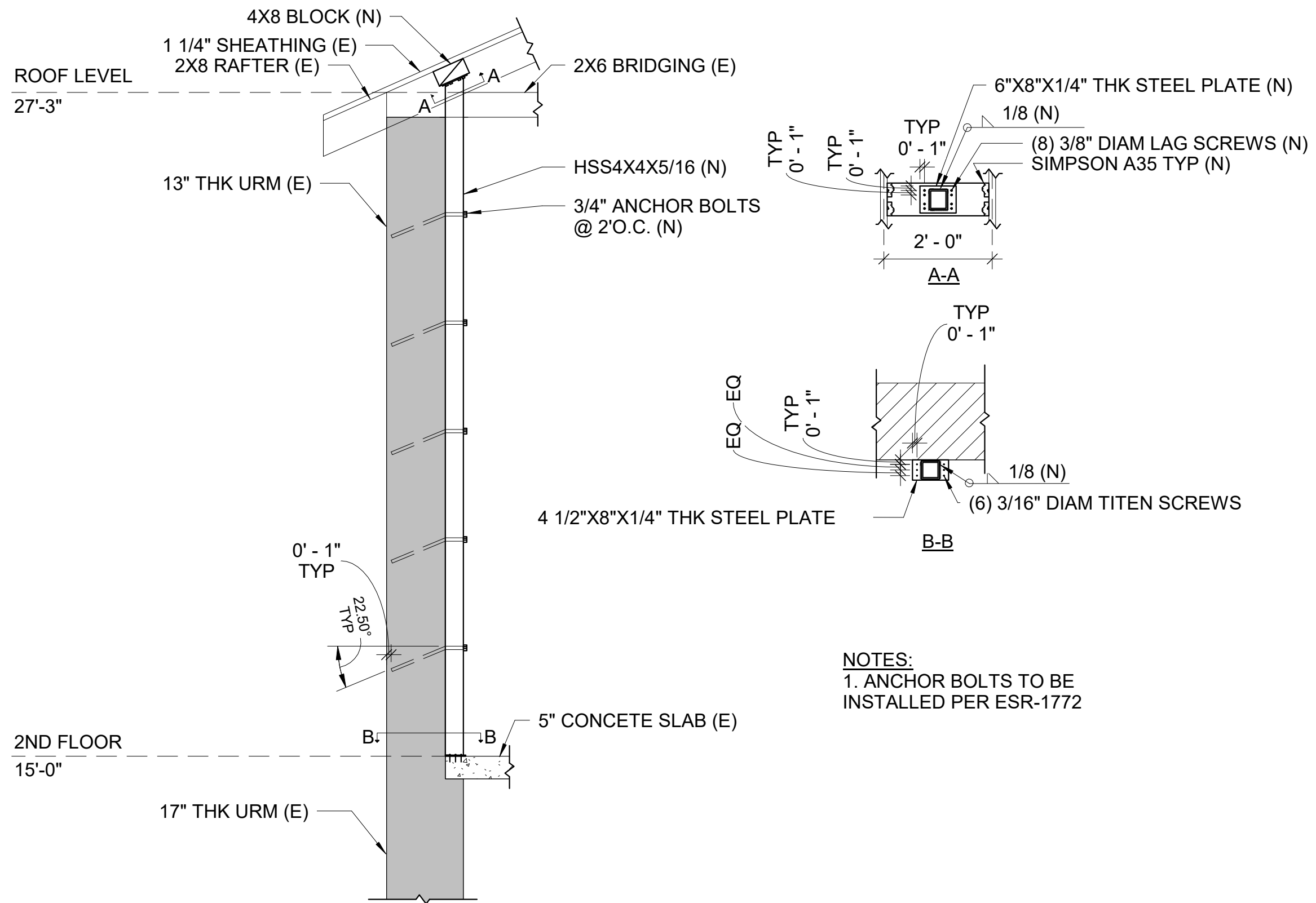

NOTES:
1. ANCHOR BOLTS TO BE INSTALLED PER ESR-1772

TYP STRONGBACK ELEVATION 2ND FLOOR
1/2" = 1'-0"

ATASCADERO PRINTERY
ATASCADERO, CA 93422

DETAILS

SCALE: 1/2" = 1'-0"

S5

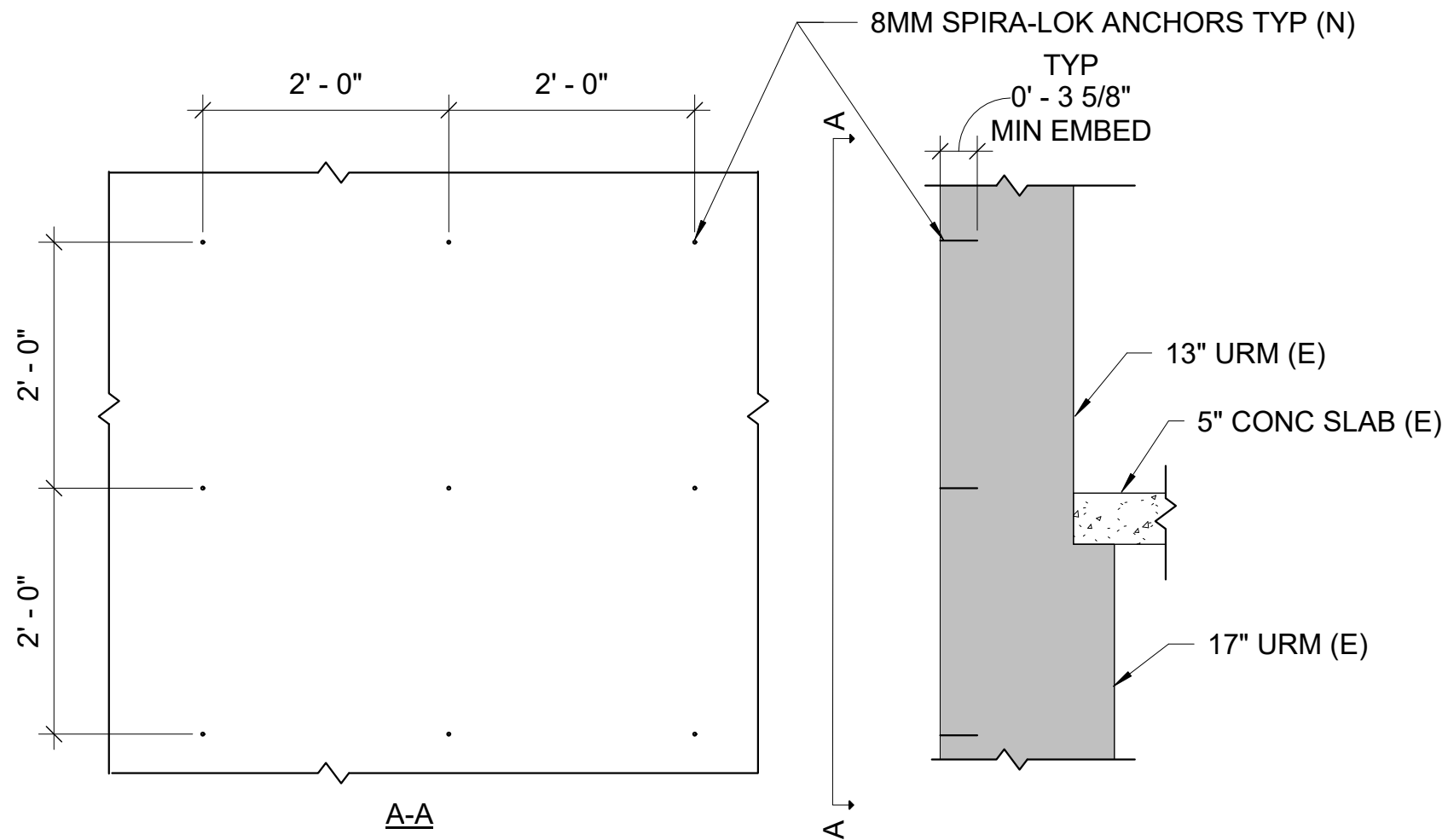

NOTE:
BLOK-LOK SPIRA-LOK ANCHORS TO BE APPLIED TO ALL EXTERIOR URM EXTERIOR FACES EVERY 4 SQUARE FEET AS SHOWN. INSTALL PER BLOK-LOK REQUIREMENTS.

① VENEER ANCHORS
3/4" = 1'-0"

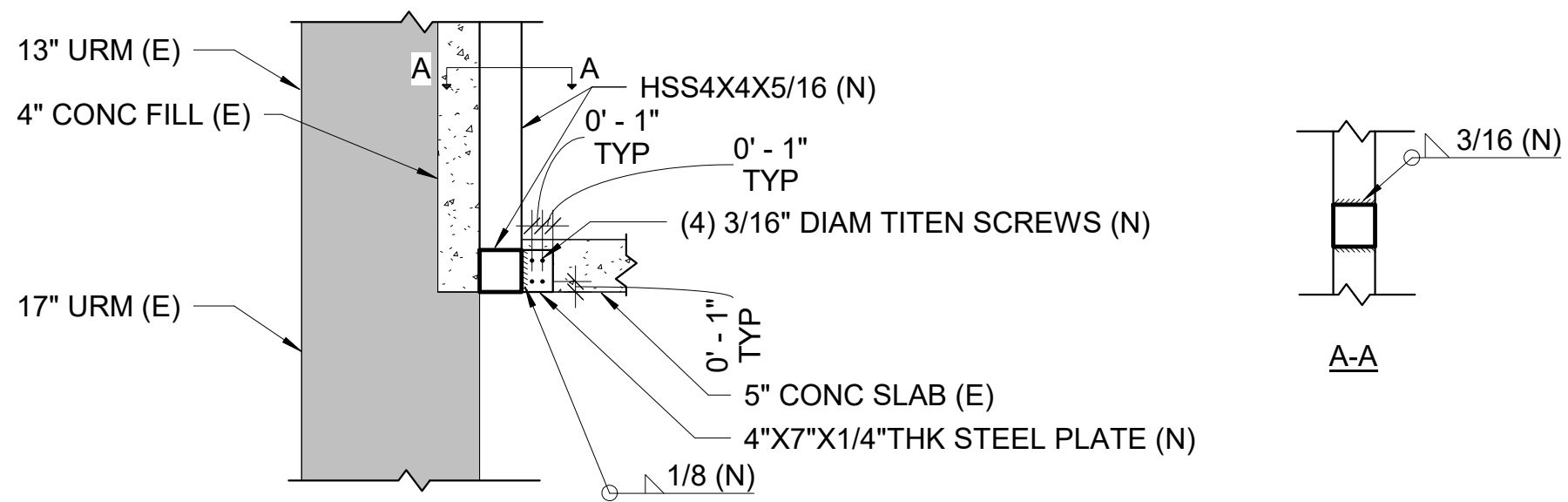

② TYP STAIRWELL STRONGBACK CONNECTION
3/4" = 1'-0"

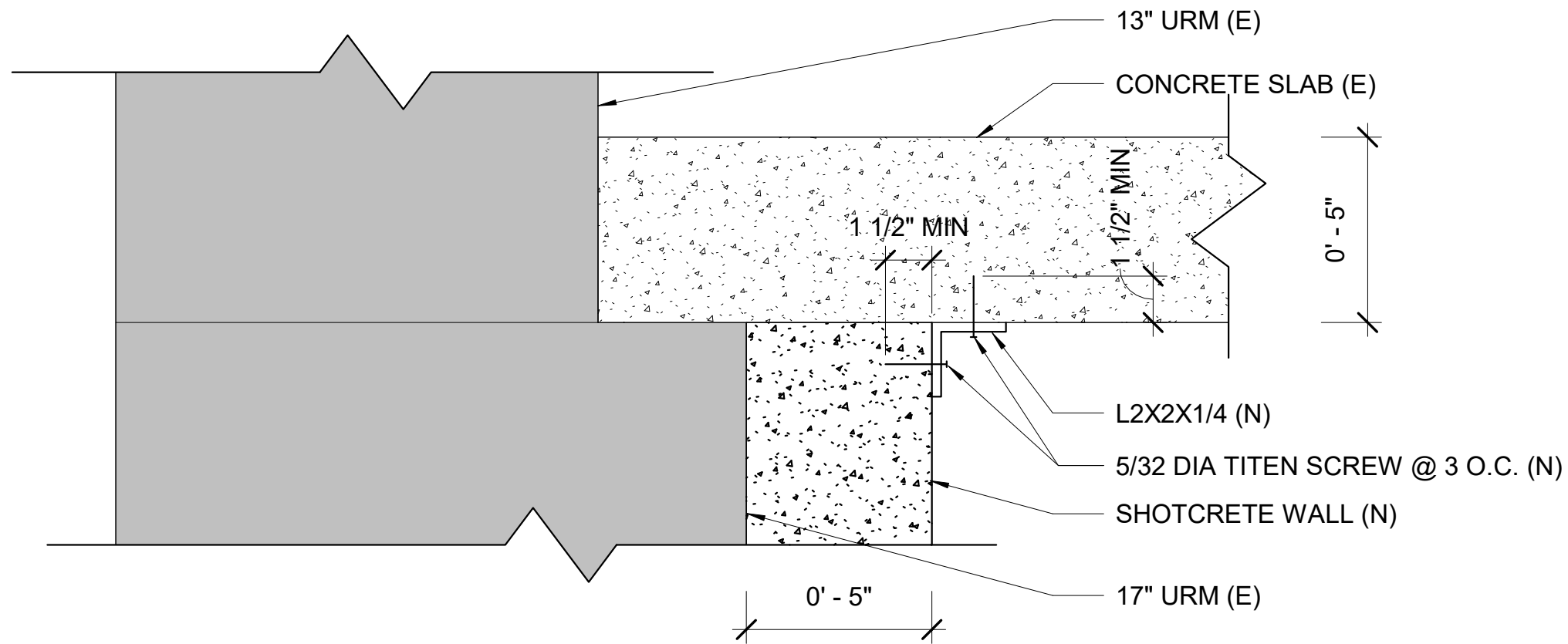

1 SHOTCRETE WALL TO FLOOR SLAB CONNECTION
3" = 1'-0"

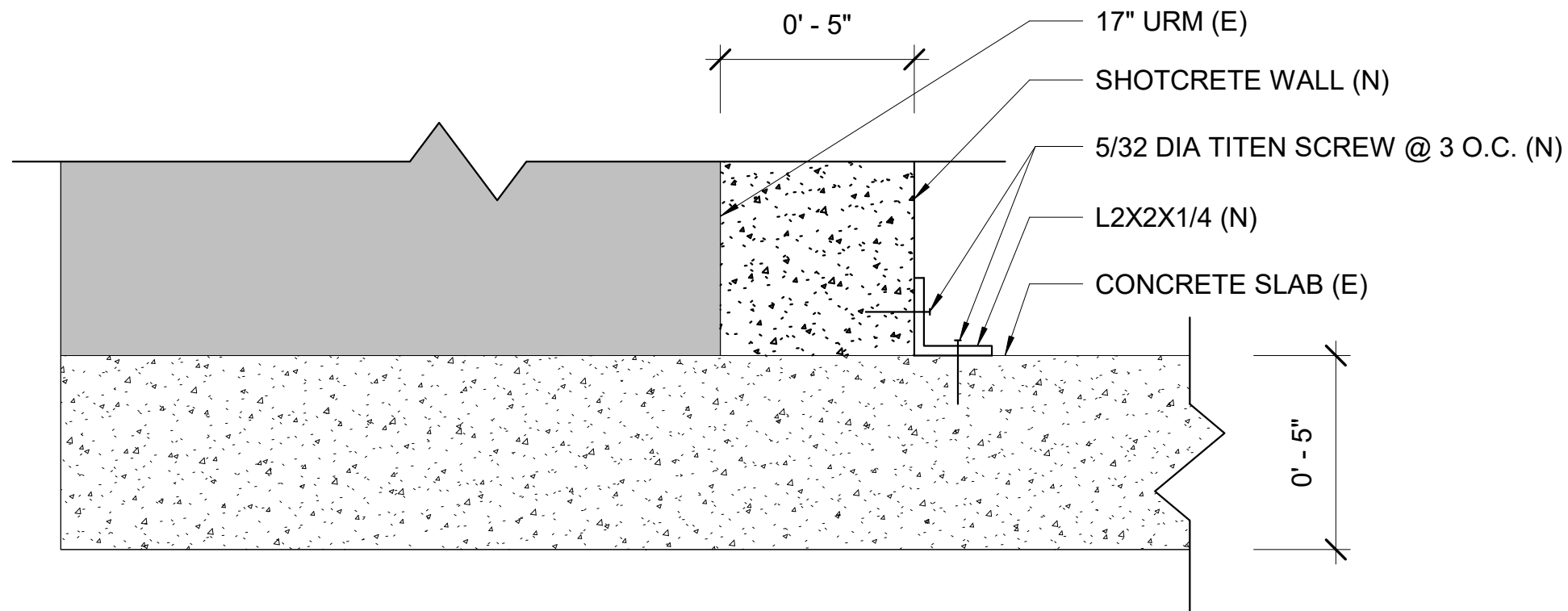

2 SHOTCRETE WALL TO FOUNDATION CONNECTION
3" = 1'-0"

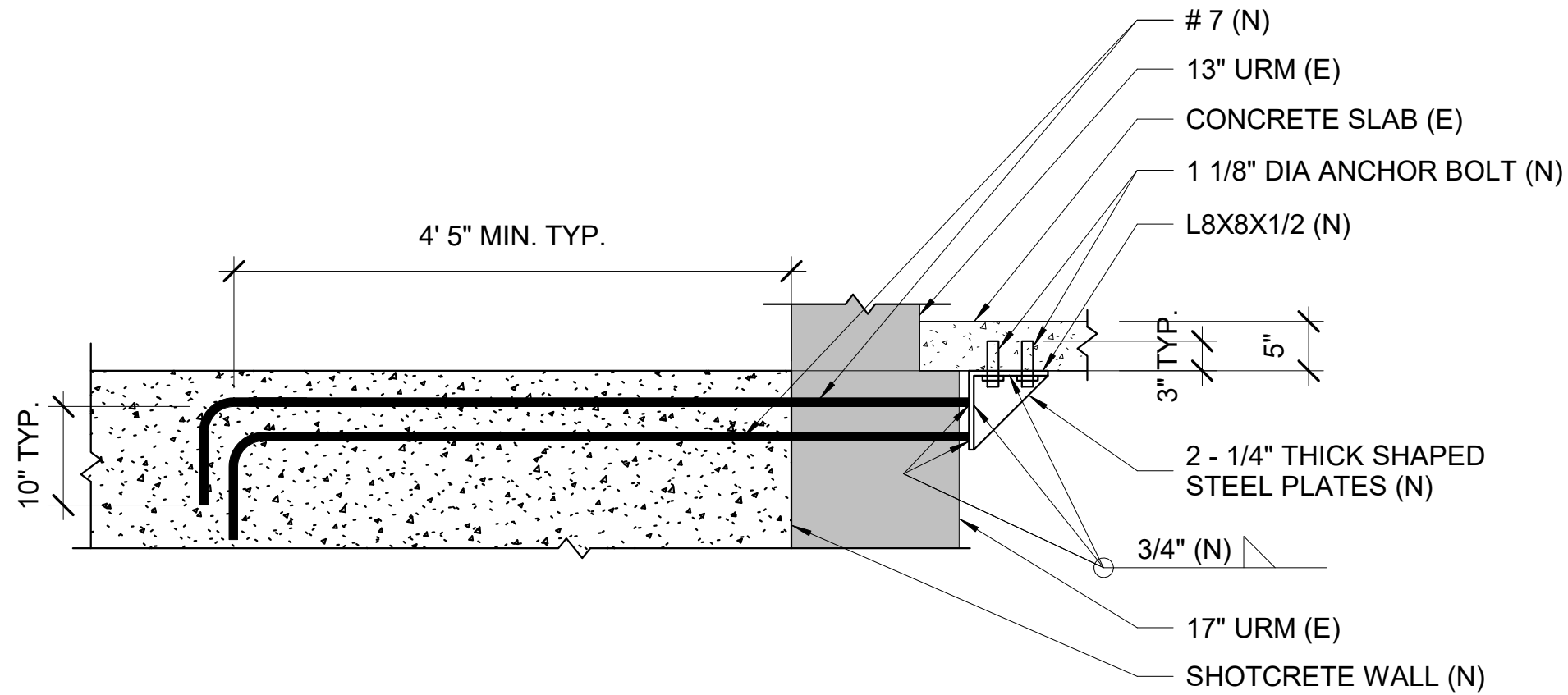

① SHOTCRETE WALL TO MAIN BUILDING CONNECTION
3/4" = 1'-0"

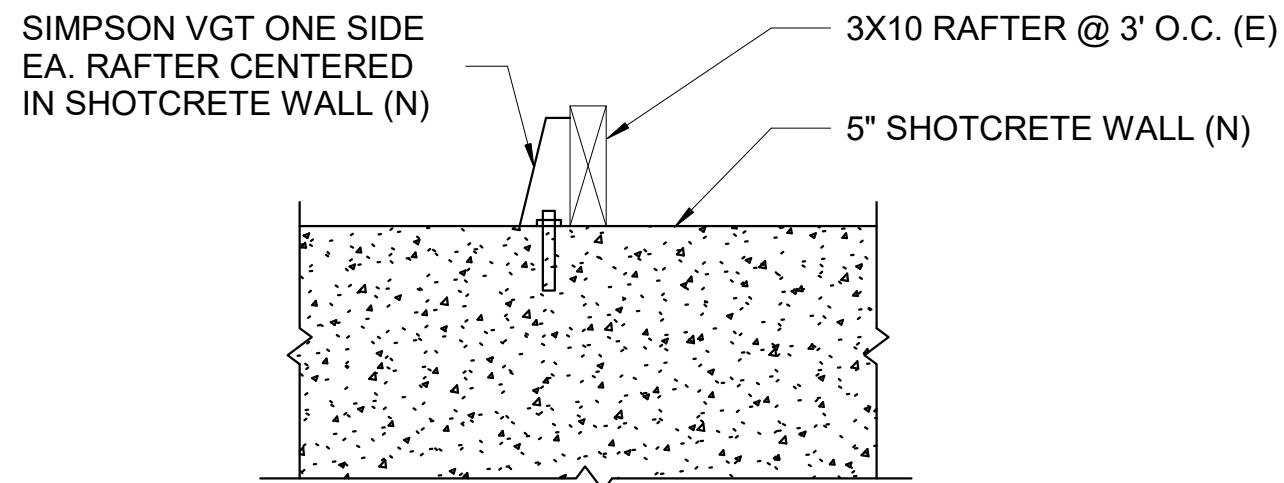

② SHOTCRETE WALL TO ROOF CONNECTION
3/4" = 1'-0"

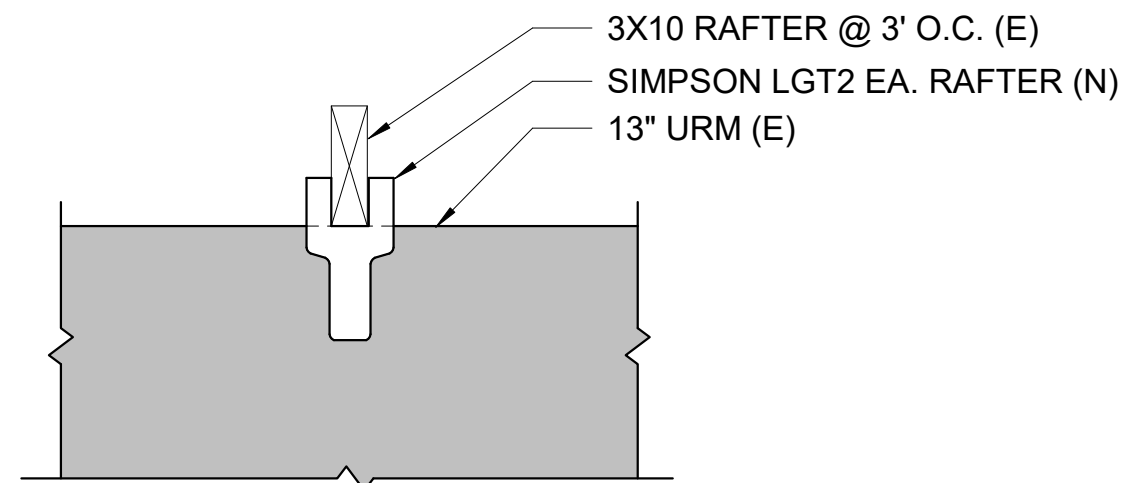

③ WALL ANCHOR
3/4" = 1'-0"