

Testing setup for automatic cycling of metal hydride composites

M. Dieterich*, I. Bürger, M. Linder

German Aerospace Center (DLR), Pfaffenwaldring 38-40, 70569 Stuttgart, Germany

*: mila.dieterich@dlr.de

In a future hydrogen community, metal hydrides can be used in several new applications. The most common application is as hydrogen storage material for stationary or mobile applications. However, there exist plenty of other applications like heat storage systems, thermal compressors, air conditioning systems, hydrogen purifying systems, etc.

For all of these applications cycling stability is a major issue as it determines operational strategies as well as overall lifecycle cost. For pure materials, there exist studies on several thousands of cycles as these materials can be tested in very low quantity and accordingly in small apparatus. However, due to the low thermal conductivity of the powder as well as the low powder density, it is very common to press these powder materials into pellets, and add e.g. expanded natural graphite to improve the thermal conductivity. For these kind of composites it is not only required to determine the stability of the absorbed amount of hydrogen, but also to determine e.g., the geometric stability or the stability of the thermal conductivity.

The present setup, that has been built in the framework of a German BMBf Project “HD-HGV” (grant number 03EK3020), is able to test the geometric stability of such pellets in a fully automatic manner up to 1000s of cycles. The hydrogen uptake (of up to 1.8 g of H₂) is measured by the Sieverts method and it is possible to measure up to 4 different pellets in parallel. The temperature of the materials can be varied between -20 °C and 330 °C and the pressures between 10¹ ... 10⁷ Pa.

So far with this setup hydride-graphite composites of the following materials have been tested: Hydralloy C5 [1], MgH₂ and NaAlH₄.

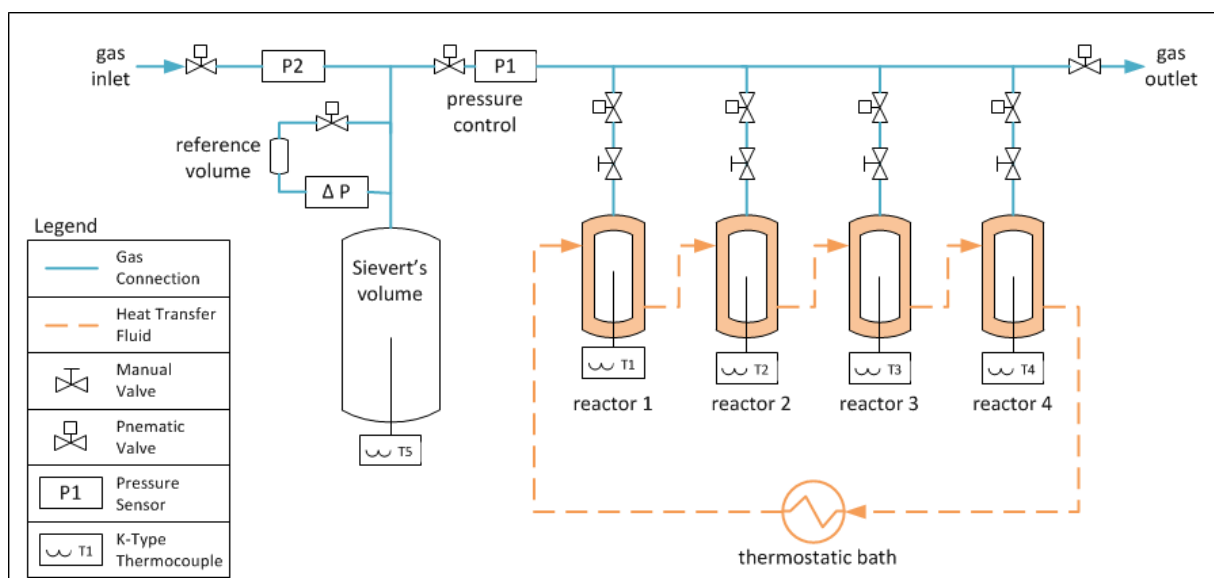

Figure 1. Schematic layout of the test bench [1]

References:

- [1] M. Dieterich, C. Pohlmann, I. Bürger, M. Linder, L. Röntzsch, Long-term cycle stability of metal hydride-graphite composites, *Int. J. Hydrogen Energy*. (2015). doi:10.1016/j.ijhydene.2015.09.013.