

The Lunar Lander Neutron & Dosimetry (LND) Experiment on Chang'E4. R. F. Wimmer-Schweingruber¹, S. Zhang², C. E. Hellweg³, J. Yu¹, J. Guo¹, H. Lohf¹, T. Berger³, S. I. Böttcher¹, S. Burmeister¹, M. Jüngling¹, A. Knappmann¹, V. Knierim¹, B. Schuster¹, L. Seimetz¹, G. Shen², J. Steinhagen¹, B. Yuan², ¹Institute f. Experimental & Applied Physics, University of Kiel, Germany (wimmer@physik.uni-kiel.de), ²National Space Science Center (NSSC), Chinese Academy of Science, Beijing, China, ³Institute for Aerospace Medicine, DLR, Cologne, Germany

Introduction: Chang'E 4 is the next Chinese mission to the Moon and is planned to land on the far side of the Moon in the South Pole Aitken Basin. The mission consists of a lander, a rover, and a communication relay. Here we describe the Lunar Lander Neutrons & Dosimetry experiment (LND) which will be placed on the lander. It consists of a stack of 10 segmented Si solid-state detectors (SSDs) which forms a particle telescope to measure charged particles (electrons 150-500 keV, protons 12-30 MeV, and heavier nuclei 15-30 MeV/nuc). A special geometrical arrangement allows observations of fast neutrons (and γ -rays) which are also important for dosimetry and cosmic-ray exposure of lunar soils. Thermal neutrons are measured using a very thin Gd conversion foil which is sandwiched between two SSDs. Thermal neutrons are sensitive to subsurface water and important to understand lunar surface mixing processes.

Despite the aim of landing humans on the Moon in the not too distant future, radiation measurements in the vicinity of the Moon are remarkably scarce. Fairly recent measurements in lunar orbit were provided by the Radiation Dose Monitor (RADOM) on board Chandrayaan-1 [1]. The spacecraft reached its operational 100 km circular orbit on November 12, 2008. Measurements showed a dose rate of 0.227 mGy per day averaged over 3545 hours of measurement time (20/11/2008 to 18/5/2009). Newer measurements have been provided by the Cosmic Ray Telescope for the Effects of Radiation (CRaTER) instrument [2] on board the Lunar Reconnaissance Orbiter (LRO). CRaTER measured a radiation exposure of about 0.22 – 0.27 mGy per day in its 50 km orbit. In comparison with these meager orbital data, there is a real dearth of data on the lunar surface. The current knowledge about the radiation environment on the surface of moon is based exclusively on calculations using radiation transport models with input parameters from models for the galactic cosmic ray spectra and for solar particle events. This is highly questionable, especially since we know that these models are fraught with uncertainties [3]. Measurements of the lunar neutron density at depths of 20 - 400 g/cm² within the lunar subsurface were performed during the Apollo 17 mission [4].

Science and Measurement Objectives: To improve our knowledge of the surface radiation field on

the Moon, LND will provide the following measurements. 1) Time series of the charged and neutral particle dose rate in Si at a cadence of 1 minute. 2) Charged particle spectra at a cadence of 5 minutes. 3) Count rates of thermal neutrons at a cadence of 5 minutes. 4) LET-spectra in the range 0.1 – 430 keV/ μ m at a cadence of 15 minutes. 5) Fast neutron spectra in the energy range from 1 to 20 MeV at a cadence of 15 minutes. 6) Composition of the radiation, which is important for dosimetry, at a cadence of 30 minutes.

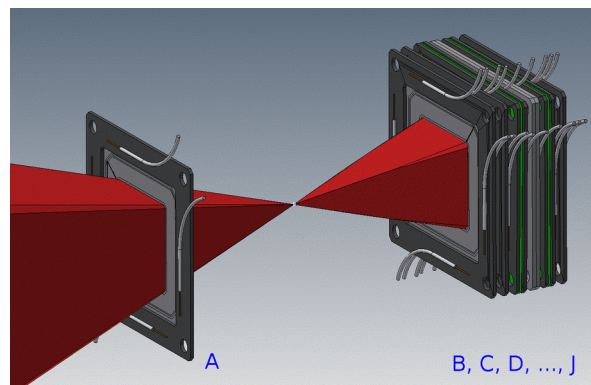

Fig. 1: LND measures charged particles with a stack of 10 Si solid-state detectors. A is the entrance detector on the left, B the first detector in the stack to the right. The following detectors (C,...,J) complete the stack.

Instrument Description: LND is largely based on developments which were performed for the Ionizing Radiation Sensor (IRAS) for Exomars. It consists of a sensor head viewing the zenith direction and a separate electronics box. It is housed in the instrument compartment of the Chang'E4 lander. A single LND detector has a geometric factor of 28.3 cm²sr, which allows for a high count rate of ~35 counts/sec per single detector. The inner segments of the top two detectors (A2B2, see Fig. 1) have a geometric factor of 2.54 cm²sr and we expect approximately 3 counts/sec in coincidence. This high count rate allows to determine statistically significant variations in the dose rate during solar particle events, and to determine particle spectra within the times given in the previous section. The total thickness of the stack allows us to stop 30 MeV protons and relativistic electrons. The last detector (J) serves as anti-coincidence.

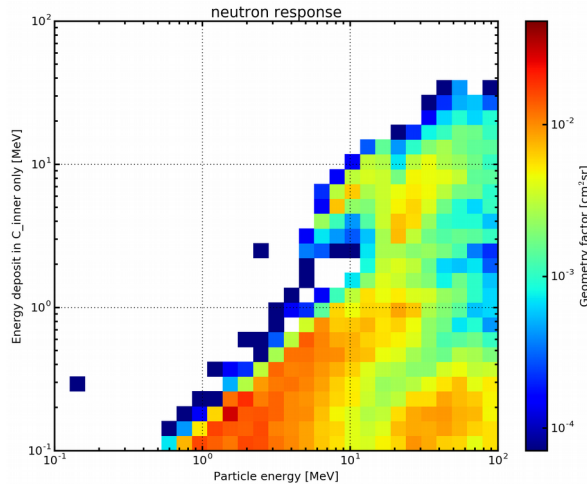

Fig. 2: LND instrument response function for fast neutrons serves as input for the inversion process which is needed to obtain the fast neutron spectrum.

Fast neutron detection. The first three segmented detectors in the stack shown to the right in Fig. 1 (detectors B, C, and D) are placed very close together. Thus, detectors B and D serve as anti-coincidence (AC) for the inner segment of detector C. The outer segment of C closes the AC. Such a configuration has been calibrated and flown on a high-altitude balloon, demonstrating the measurement technique. Neutron spectra can be determined using an inversion similar to that performed with the Radiation Assessment Detector (RAD) on MSL [5]. The LND instrument response function for fast neutrons is shown in Fig. 2 and is needed as input to the inversion technique. It has been simulated using GEANT4. LND's neutron response will be calibrated at the Physikalisch Technische Bundesanstalt (PTB) in Braunschweig, Germany.

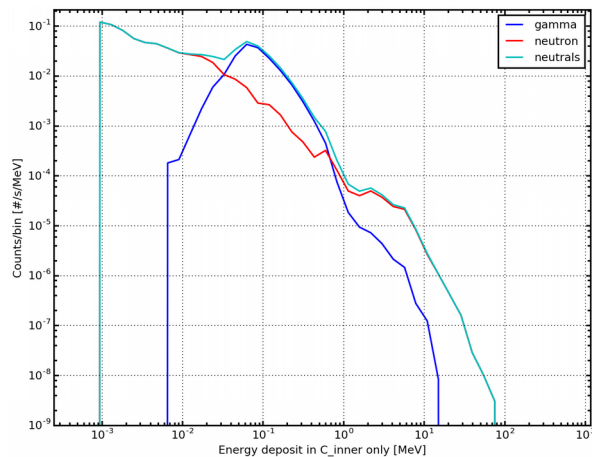

Fig. 3: Simulated neutron energy deposit spectrum in the inner segment of detector C.

Thermal neutron measurement: Natural Gadolinium (Gd) has a large cross section (49'700 barns) for capturing thermal neutrons. After capture, the excited nucleus decays via internal conversion or γ -decay. The conversion electrons have enough energy to penetrate the thin (5 μm) foil and stop in the neighboring 500 μm SSDs which form the Si-Gd-Si sandwich and are part of the LND detector stack (right in Fig. 1). LND has two such sandwiches which are separated by a thick (200 μm) Gd foil encased in 500 μm Al. This allows us to measure thermal neutrons coming from beneath and above the lander. The ratio of the two measurements is sensitive to the subsoil water content beneath the lander in comparison to a larger surrounding area because thermal neutrons do not achieve lunar escape speed. LND will be able to detect temporal variations between dawn and dusk. Lander (and rover) will be turned off during lunar night.

Linear Energy Transfer (LET) measurements: LND measures the three different LET spectra shown in the table below. Knowledge of the LET spectrum is crucial for an accurate dosimetry measurement and to assess the energy input into lunar soils. LND measures LET spectra in the energy range from 0.1 to 430 keV/ μm . The lower value lies well below the energy input from minimally ionizing particles (MIPs), the upper end encompasses the energy deposition of MIP iron nuclei.

LET spec.	trigger	Geo. Fac.	Counts/sec
High-prec.	B2 \otimes A2	0.4 cm ² sr	0.7
precision	B2 \otimes (A1&A2)	0.8 cm ² sr	1.4
fast	B2 \otimes (I1&I2)	7.4	11

The combination of the three LET spectra will allow LND to accurately determine the energy input of solar particle events into lunar soils.

Current Status: The LND EM was delivered to NSSC which is in charge of payload AIVT in December 2016. The LND flight unit is scheduled for delivery early April 2017. The launch of Chang'E4 is foreseen in the fourth quarter of 2018.

References:

- [1] Dachev, T. P, et al. (2011) *ASR*, 48, 779–791.
- [2] Spence H. E. et al. (2010) *Space Sci. Rev.*, 150, 243–284.
- [3] Mrigakshi, A. et al. (2012), *JGR (Space)*, 117, A08109,
- [4] Woolum D. S. (1975) *Moon*, 231–250.
- [5] Köhler J. et al. (2014) *JGR (Planets)*, 119, 594–603

Acknowledgements: LND is supported by the German Space Agency (DLR) under grant 50JR1604.