



Conference Proceedings

Solar World Congress 2015
Daegu, Korea, 08 – 12 November 2015

Performance of a Solar EV Charger in the Pacific Island Countries

Alvin. A. Datt, Aman Singh and Atul Raturi

University of the South Pacific, Suva (Fiji)

Abstract

The unsustainable dependence of the Pacific Island Countries (PICs) on imported fossil fuels and climate change concerns have made the region to look for alternative sources for energy. A major portion of fossil fuels goes towards transportation and it is imperative that other options such as biofuels and hybrids/ EVs are seriously explored. Considering the small distances involved, EVs can be profitably deployed in urban areas and also within the myriad tourist resorts spread across the Pacific islands. Solar PV based charging stations can play a major role in this endeavor. This paper describes the design and performance of first solar electric vehicle (EV) charging station in the Pacific Island Countries. The actual performance of this 2.6 kW_p station is compared with the simulated results obtained using HOMER. Finally, the paper also looks at the way forward for development of electric mobility in the region.

Keywords: Pacific Island Countries (PICs), Electric Vehicles, Solar PV

1.0 Introduction

1.1 Energy situation in Fiji and the Pacific Island Countries

The Pacific Island Countries (PICs) are heavily dependent on the imported fossil fuels for their day to day energy needs. These countries end up spending huge amount of their budget on fossil imports. For instance, the petroleum imports for Fiji have increased from about \$400million in 2004 to over \$1.2billion in 2008 which tends to account for a quarter of country's total imports[1]. The dominance of transportation sector in the imported fuel usage in Fiji is quite evident from the figs.1 & 2:

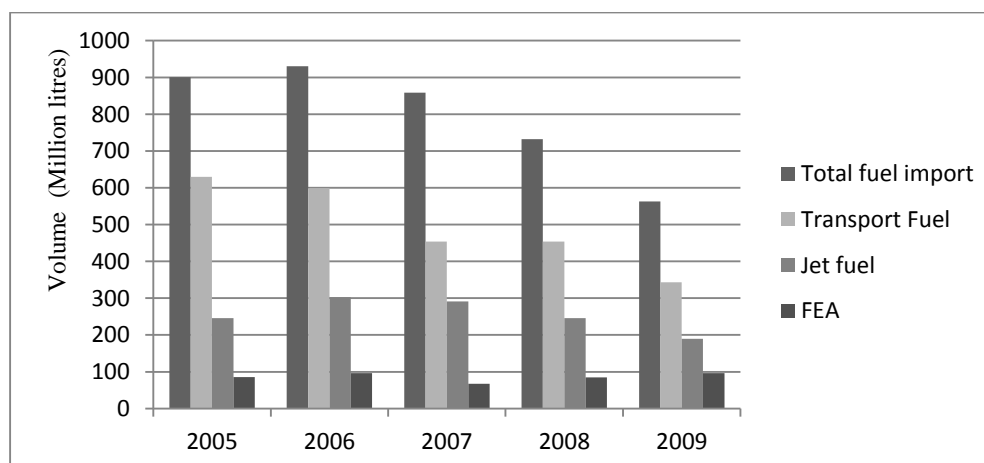

Figure 1: Fuel Import Levels in Fiji
(Source: <http://www.irena.org>)

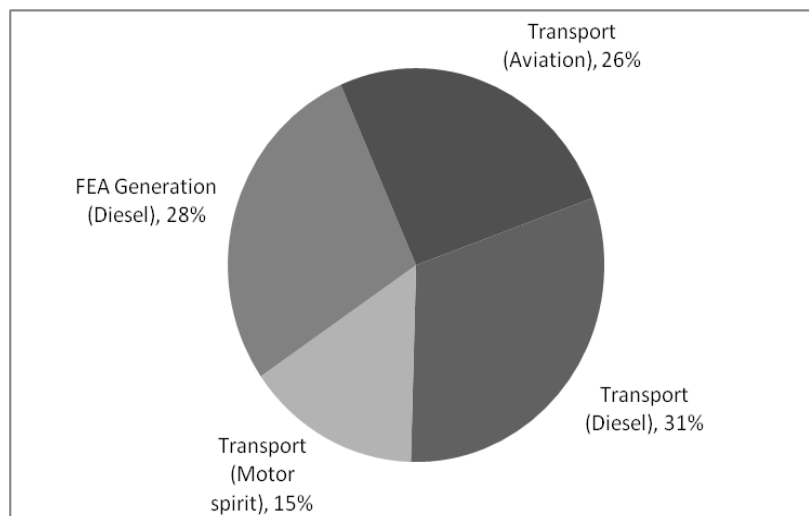

Figure 2: Oil Imports – RBF Estimates (2008 – 2011)
(Source: National Energy Forum - Reserve Bank of Fiji)

The Asian Development Bank's report launched in 2013, projects that under the present scenario, Fiji's energy demand will increase at an annual rate of 1.7 percent through the year 2035[2]. It also highlights the fact that the price of fuel in the Pacific is one of the highest in the world and only about 30% of households have access to electricity on average. Hence, the dependency of the PIC's on imported fuels for power generation hinders economical development since energy is a major driving force for the industrial and transportation sectors. The PICs' heavy dependence on the fossil fuels can also be noticed by the figures discussed in International Renewable Energy Associations policy report where it estimates that 80 percent of regions primary energy consumption is based on oil of which 75 percent is used by the transportation sector and more than 20 percent is being used for electricity generation [3].

1.2 The Development of Solar Electric Vehicles

An important development in terms of photovoltaic technology has been the introduction of solar charging stations for the charging of electric plug – in vehicles. The whole idea to use solar powered electric vehicles is to increase the use of renewable energy, and provide electric vehicle owners with a greener charging option. According to [4] "Electric cars are already among the cleanest-running vehicles on the road—charging them on solar makes them that much better". Obviously, if a EV charging station uses electricity mostly from burning fossil fuels, then the EV is simply outsourcing the pollution to the power plant.. But using electricity from solar panels erases this predicament [5].

A plug-in electric vehicle (PEV) is defined as any motor vehicle that can be recharged from any external source of electricity and the electricity is stored in rechargeable battery packs. PEV is a subcategory of electric vehicles that includes all-electric or battery electric vehicles (BEVs), plug-in hybrid vehicles, (PHEVs), and electric vehicle conversions of hybrid electric vehicles[6]. In the recent years, environmental and climate-change impacts of the petroleum-based transportation infrastructure, along with the uncertain oil prices, have led to renewed interest in an electric transportation infrastructure.

A recent study investigated the question of which alternative energy (Photovoltaic or biofuel) would be best for powering electric vehicles. The study explored the impacts of biofuels and PV on direct land use, greenhouse gas emissions, and lifecycle greenhousegas emissions. In all three categories Photovoltaic technology was found to be more efficient and beneficial [7].

A number of companies like Ford, Toyota, Nissan, and of course Tesla to mention a few, have been quite active in the development of electric vehicles and more car manufacturers are now developing their electric

versions [8,9] However with the widespread implementation of electric vehicle networks within large cities, such as those provided by POD Point [6] in the UK and Europe, EV users can plug in their cars while at work and leave them to charge throughout the day for charging, hence solving the problem of driving range of the EV as enough charge would be available all the time.

Furthermore, Electric car maker Tesla has installed its “Supercharger” rapid car charging network at different locations throughout California. Superchargers are powered by solar technology, developed by solar installer Solar. The Superchargers can charge the Model S cars with 100 kilowatts of power and provide three hours of driving at 60 mph in about half an hour [9].

The solar-assisted charging stations use solar photovoltaic (PV) arrays to generate electricity to charge the electric vehicles. The Oak Ridge National Laboratory (ORNL) conducted a demonstration project involving solar assisted charging stations for EVs (2009-2014) . The project objective were to install 125 solar EV chargers and study their impact on the grid . The systems were grid-connected to enable charging at all times .and an external battery was employed to offset grid demand if needed.. The installed PV power per parking space was sufficient to support 10,000 miles driving per year.. One of the project collaborators, Nissan North America, installed 30 solar powered charging stations.[10].

After going through the developments in the sector of electric vehicles and the solar charging stations globally, it can be realized that the potential for such a development is high but there are certain factors like the availability of enough solar charging stations, and the driving range of the electric vehicles that need to be considered. The idea of battery swapping at stations located on regular distance can prove to be a solution for the driving range problem of EV's considering that installing solar charging stations on a number of locations would become an expensive course. According to [11] instead of recharging EVs from electric socket, their batteries could be mechanically replaced on special stations in a few minutes.

1.0 The Solar Charging Station

2.1An Overview

An important aspect of any solar charging station is the installation of the panel and other components such as battery and the charge controller of the system.

Solar Panel –A solar panel is made up of a number of series and parallel combinations of identical individual cells to generate the desired power output (current and voltage). Panels are assigned a power rating in watts based on the maximum power they can produce under ideal sun and temperature conditions. The rated power output is used to help determine how many panels are needed to meet the electrical load demands. Multiple panels combined together are called solar arrays [11]. PV solar array is normally mounted on a canopy above the solar-assisted EV parking spaces. In addition to providing a mounting structure for the solar PV array, the canopy provides shading and protection for the components and also helps to keep the vehicle cool during charging. The canopy solar PV modules are electrically connected in a parallel/series arrangement to supply the optimal direct current (DC) voltage to the inverter. The inverter converts direct current from the array to alternating current to feed to the power grid through a transformer [10].

Battery – electrical utility supplying power for the charging stations and is concerned about surge loads on the grid from vehicle charging. The function of the battery banks is to store energy on site, charging the batteries during periods of low charging demand, and discharging the batteries back into the electrical grid during high demand to minimize the surge load on the grid [10].

Charge Controller - a device that is very important because it blocks reverse current, prevents overcharging and discharging of the batteries and protects battery from overloading [12].Hence it prevents the battery from reduced lifespan. Charge controllers come in all sizes, and protection and monitoring features. The selection depends on the size of installed solar panel(s) and the complexity of loads and future expansion possibility. Different charging and maintenance algorithms are used depending on the type of the battery [11].

2.1.1 An Overview of the Project

The project of solar charging station at The University of the South Pacific was funded by the French Government under the Pacific Funding Programme. The major aim of the project is demonstrate one of the the climate change mitigation strategies in the region by moving towards a more sustainable form of energy for the transportation sector, help the students at the university with research in the field area and create awareness of the solar charging stations for electric vehicles..



Figure 3. The solar charging station roof mounted panels with two supports to allow for vehicle parking and charging area

2.1.1.1 The Technology Overview

Table 1. Power System details

	Description
Solar Panels (2.625kWp)	BP Solar BP4175
Array Frame	Roof mount array aluminium Unirac module mounting rack
Batteries	Haze – HZYSL6 – 225, 6V @C100 (Gel)
Solar regulator	Outback FM60 60A MPPT
Inverter (240V, 50H)	Outback GFX1424, 1400W, 24V
Monitoring & Control	Outback Mate3, FlexNet DC

2.1.1.2 Station Design

The solar array is mounted on the roof on top of the equipment hut using Unirac rails and clips. The roof of the hut is tilted at latitude angle (18 degrees) and faces due north for the best annual performance of the

panels. Four Haze (Gel) batteries , a charge regulator and an inverter are mounted inside the hut.

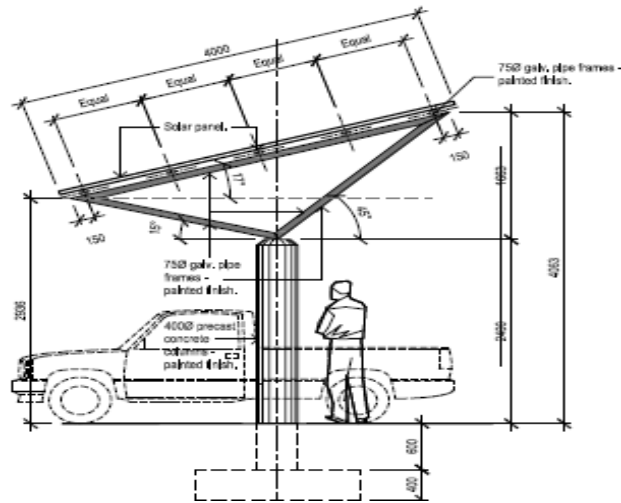

Figure 4. Construction plan for the charging station

2.1.1.3 System Features

A fully integrated and automated monitoring Outback system is installed to monitor the performance of the system. The FlexNET DC coupled with MATE3 provides advanced monitoring and control features. The MATE3 has an integrated data logger which can record system readouts for up to a year and hence allows for remote access and control. FlexNET DC collects, monitors and records time based battery amp, watt and voltage data for display on Outback MATE components. This provides data for precise battery recharging. There are five LEDs on the FlexNET DC that act as state of charge indicator bar. The advanced recording features of the system allows for the remote access of data for PV array performance, battery usage and load parameters.

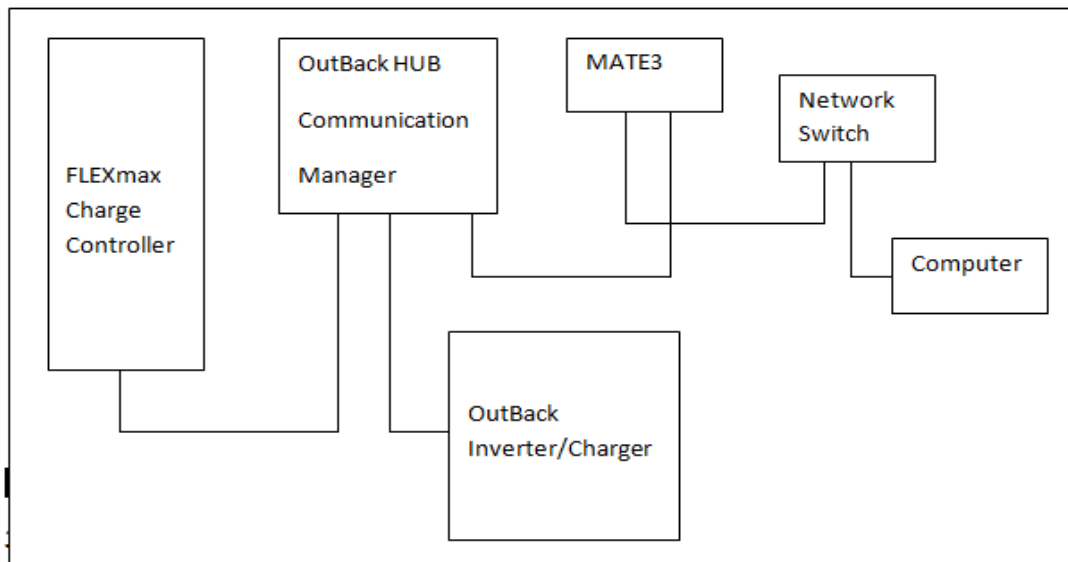

Figure 5. System Diagram

2.1.1.4 Solar Panel

Table 2. Electrical Characteristics of solar panel

	STC 1000W/m ²	NOCT 800W/m ²
Maximum power (P _{max})	175W	126W
Voltage at P _{max} (V _{mpp})	35.4V	31.5V
Current at P _{max} (I _{mpp})	4.94A	3.95A
Short circuit current (I _{sc})	5.45A	4.41A
Open circuit voltage (V _{oc})	43.6V	39.7V
Module efficiency	14.0%	
Tolerance P _{max}	3/+5%	
Nominal voltage	24V	
Efficiency reduction at 200W/m ²	<5% reduction (efficiency 13.3%)	
Limiting reverse current	5.45A	
Temperature coefficient of I _{sc}	0,105%/ °C	
Temperature coefficient of V _{oc}	-0,360%/ °C	
Temperature coefficient of P _{max}	-0,45%/ °C	
(3) NOCT	47±2°C	
Maximum series fuse rating	20A	
Application class (according to IEC 61730:2007)	Class A	
Maximum system voltage	600V (U.S. NEC) 1000V (IEC 61730:2007)	

[Source: <http://www.wfsenate.co.uk/media/uploads/88bb977f0e91a4459c7ee5108e61552f2570c6dd.pdf>]

2.1.1.5 I – V Characteristics

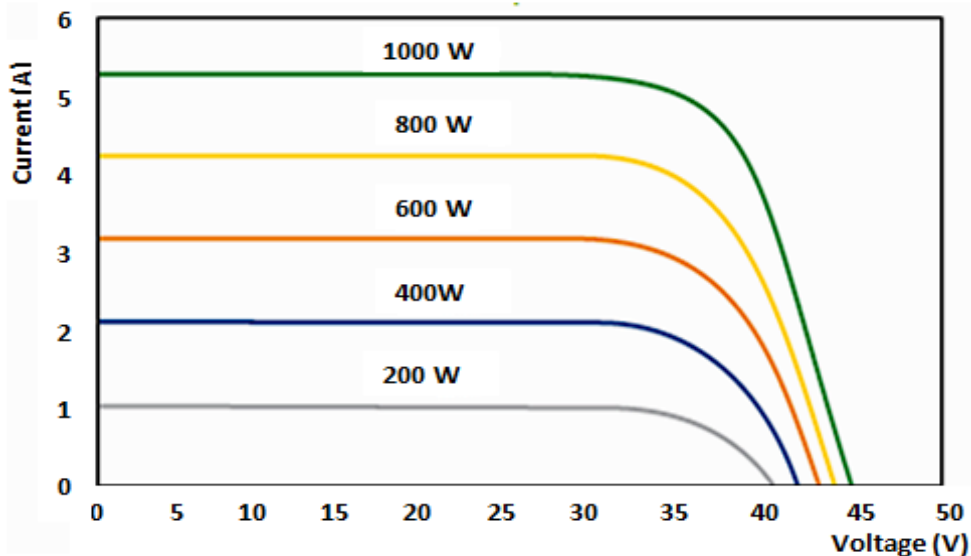

Figure 6. Dependence of the Performance of the Panel on Irradiance

[Source: <http://www.wfsenate.co.uk/media/uploads/88bb977f0e91a4459c7ee5108e61552f2570c6dd.pdf>]

2.1.1.6 Battery

Haze – HZYSL6 – 225 Gel series is lead acid type batteries. Advanced Gel design is used in these batteries and is highly suitable for cyclic solar Photo voltaic applications [13]. Some of the important Features of the battery includes; repeat cycling for daily usage, good performance over long discharges, good tolerance to high temperature applications, less self discharge, good charge acceptance due to low internal resistance and it can be discharged even when not fully charged without the loss of battery capacity [13].

2.1.1.7 Solar Regulator

The FLEXmax (OutBack FM60-150 MPPT Solar Controller) Maximum Power Point Tracking (MPPT) is continuous and active and helps increase the photovoltaic power yield to about 30 percent more compared to non – MPPT controllers [14]. It is able to function at ambient temperature of as high as 40° C. It also has the ability to step-down a higher voltage solar array for the recharging of a lower voltage battery bank and is able to display the current status and logged performance data for past 128 days.

2.1.1.8 Inverter

The OutBack inverter (GFX 1424, 1400W, 24V) is designed for applications to lower power demands. It comprises of a DC to AC sine wave inverter, battery charger and an AC transfer relay. It provides power back up in the event of an outage through the in- built transfer relay which acts by disconnecting the loads from the grid and powers them from the inverter [15]. Hence it helps reduce disruption in power supply in times of usage.

Results and Discussions

2.0 Solar Resource

3.1 Solar Resource at the Charging Station Site

Panel Orientation: Tilt=18° -- Azimuth=0° (Due North) -- **Skyline Heading=0°**

GPS Location: Latitude=18.14996°S -- Longitude=178.44655°E

Solar Access: Annual: 95% -- winter (May-Oct): 94% -- summer (Nov-Apr): 95%

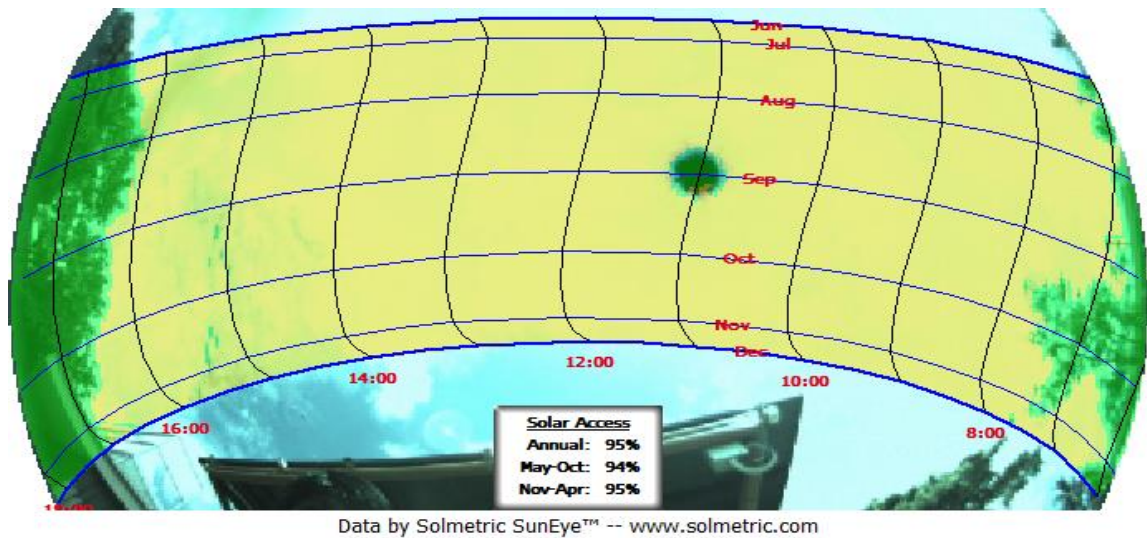
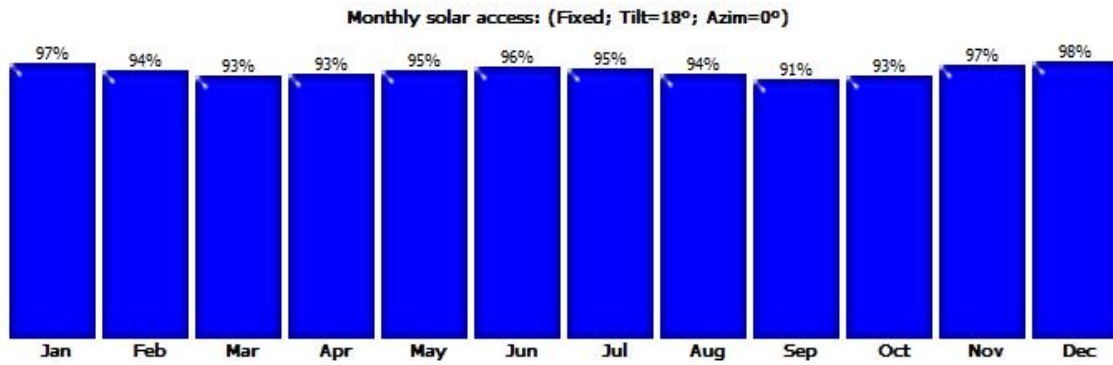

Figure7. Sunpath close to the charging station at around 11:00 a.m

The view in fig. 7 shows the annual sunpaths drawn on top of the captured skyline. The open sky is shown in yellow and the detected shade-causing obstructions are indicated in green. Fig. 8 shows the solar access percentages at the site.



Data by Solmetric SunEye™ -- www.solmetric.com
 Figure 8. monthly solar access at the charging station site

4.0 Performance of Solar Charging Station

4.1

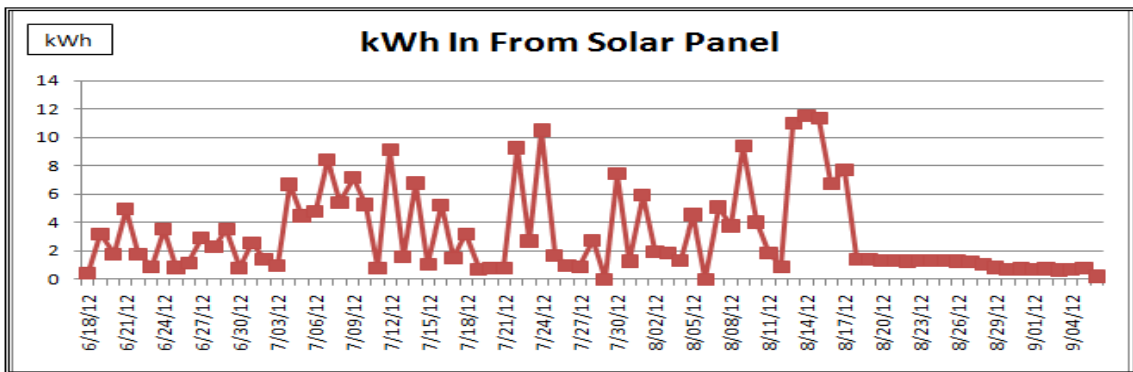

Figure 9

Fig. 9 shows the energy generation by the solar panel in kWh. The fluctuation in the production is dependent on the charging/discharging activities at the solar charging station.

The graphs in fig.10 and fig. 11 show the relationship between the energy supplied and the state-of-charge of the system battery.

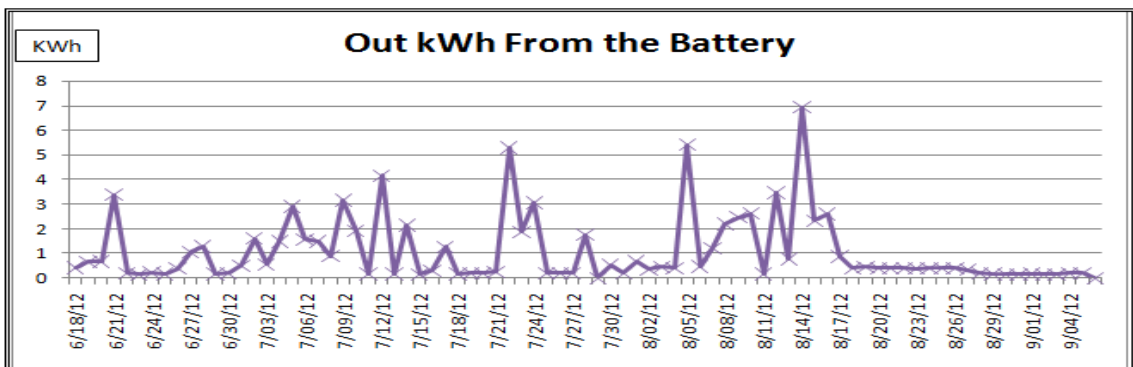

Figure 10

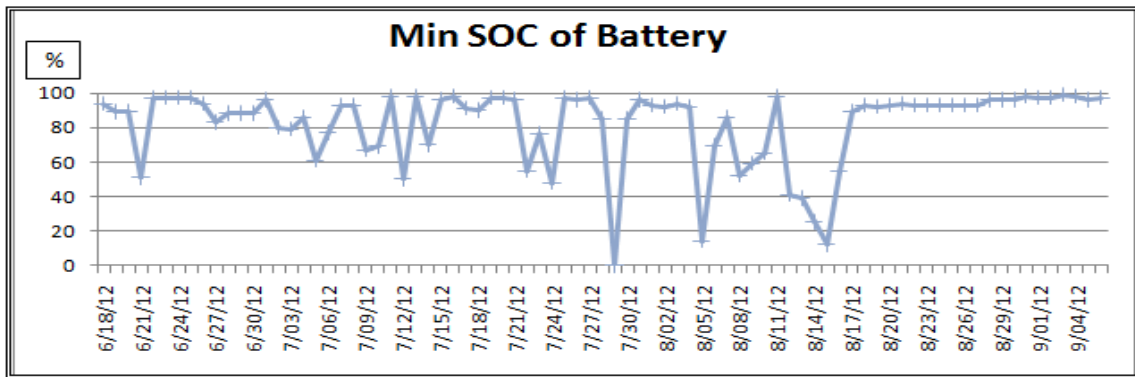

Figure 11

From the three sets of graphs above, it can be noticed that whenever there is low usage of power from the station, the state of charge of the battery is maintained above 90% and hence there is low input from the panels. However when the charging activity is high, the state of charge drops and the energy supply by the panels increases. For example, at 8/14/12, the usage is about 7 kWh, state of charge decreases below 20% and the panel produces about 12 kWh to maintain the charge status of the battery. Moreover, after 8/20/12 the charging activity is almost zero, state of charge is seen to be very close to 100% and hence the power production from the panel is also close to zero.

4.2 The Projected Output Simulations for the Charging Station

The EV charging PV system was also simulated using HOMER Software. The simulated results were given through the analysis of the input data of the system components of the solar charging station and the solar radiation data available at the location of the station. The scaled annual average horizontal solar radiation at the station location was 5.21 kWh/m²/day.

From the PV Output graph and simulation result it can be seen that an average system value of around 0.47 kW can be taken on a monthly basis. However, there are times when the panel is capable of producing around 2 kW and even higher during peak months. This result compares well with the actual production with a mean output of around 11 kWh/day.

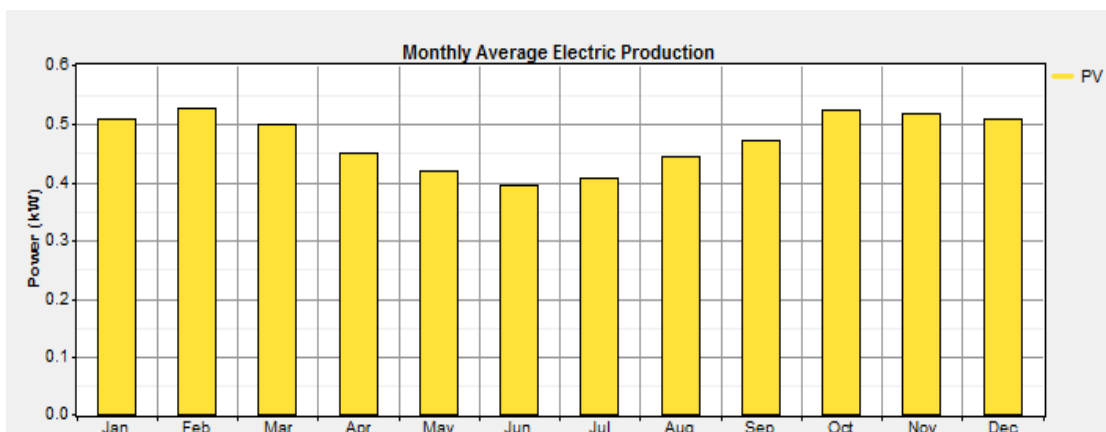

Figure 12: Monthly Average Electric Production

Table 3. The Charging Station Projected Performance

<u>Quantity</u>	<u>Value</u>	<u>Units</u>
Rated capacity	2.65	kW
Mean Output	0.47	kW
Mean energy Output	11.3	kWh/d
Capacity Factor	17.8	%

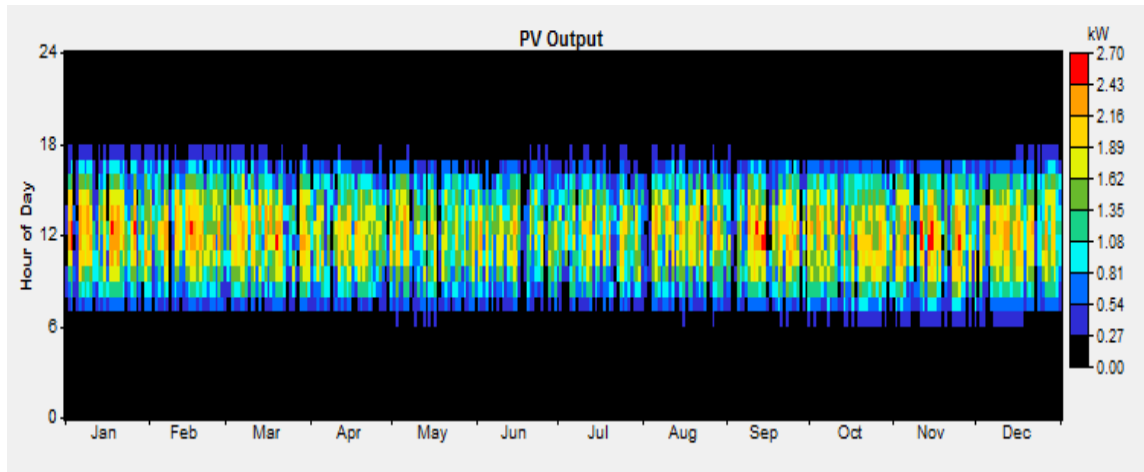

Figure 13: Output projection of the solar panel

5.0 The Scope of Solar Charging Station and Electric Vehicles in Fiji and Pacific Island Countries

The solar charging stations have a good potential in the Pacific island countries due to the availability of high solar radiation in the region. The geographical location of the PIC's gives them an advantage as they are located near the equator. For this reason charging stations can be erected at a number of places around the Pacific.

The charging stations and solar electric vehicles would be of great use to the resorts around the islands. It would provide them with an opportunity to help minimize pollution by using green energy like solar while cutting down their electricity bills and carbon footprint. The only cost involved is in the setting up of the charging station and purchasing of electric vehicle. Most of the resorts operate electric buggies/carts to transport guests and also for their golf courses. Deploying solar chargers on the myriad of resorts in the region will reduce their dependence on fossil fueled utility power or their own generators.

Moreover, the private transport companies and government can also invest in the charging stations and develop a solar EV charging car park. For example, some of the parking lots of Suva City Council and the government can be turned into solar charging stations. Most of the office/factory workers travel short distances and hence they can plug in their vehicles in the car park while they attend to their routine work. The main business districts are quite small and electric three-wheelers can be efficiently utilized for delivery etc. The government and companies can also think on the line for use of the vehicles for business purposes. Recently, electric three-wheelers have been launched in Fiji and a transport company is introducing all electric buses. The car dealers in Fiji have also started importing plug-in vehicles like Nissan Leaf and with the Fijian government's zero tax policy on Evs/hybrids, their popularity market is quickly growing. The need for developing sustainable transport solutions in the Pacific cannot be overemphasised and solar-charged EVs present a great way forward

6.0 Conclusion

Solar charged EVs present a significant potential for moving the Pacific Island Countries towards a sustainable transportation sector. The deployment of solar charging stations similar to the one presented here would help the EV market grow and protect vehicle owners from the rising fuel prices. It would also help to the issue of climate change mitigation by reducing the GHG emissions in the land transportation section. The analysis of the performance of the solar charging station indicate that a 2.65kW system at the University of the South Pacific is capable of producing a between 10-12 kWh/day. It is envisaged that in not too distant future the EV numbers would increase sizably and the solar chargers will play an important role in expanding their reach. The recent drastic reduction in solar panel prices means decreasing installation cost of charging stations and establishing solar PV as a major contributor to sustainable transport solutions. .

Web References

1. "Islands discuss energy challenges", <http://www.pacifictradeinvest.com/wp/?p=4861>. Date accessed 10/10/2014
2. <http://www.fjijun.com.fj/2013/10/16/report-warns-fiji-on-dependence-on-imported-fuel/>. Date accessed 12/10/2014
3. http://www.irena.org/DocumentDownloads/Publications/Policy_Challenges_for_Renewable_Energy_Development_PICTs.pdf. Date accessed 13/9/2014
4. "The Business Model for Solar-Powered Electric Car Charging". [David Herron](http://www.plugincars.com/solar-powered-electric-car-charging-business-model-127710.html). Available on <http://www.plugincars.com/solar-powered-electric-car-charging-business-model-127710.html> , date accessed - 15/08/14
5. "Plug-in Electric Vehicles (PEVs)". Center for Sustainable Energy, California. Retrieved 10/08/2014
6. <http://energy.gov/articles/history-electric-car> Date accessed - 12/11 /2014
7. "Photovoltaics beat biofuels at converting sun's energy to miles driven" <http://phys.org/news/photovoltaics-biofuels-sun-energy-miles.html>. Date accessed 10/10/2014
8. "New and Used Nissan Leafs" Available on: http://www.thecarconnection.com/cars/nissan_leaf. Date accessed - 02/03/2014
9. "Tesla unveils free solar-powered car charging stations for Model S owners" <http://gigaom.com/2012/09/24/tesla-unveils-free-solar-powered-car-charging-stations-for-model-s-owners/>. Date accessed – 15/08/2014
10. http://energy.gov/sites/prod/files/2014/07/f18/vss138_lapsa_2014_o.pdf . Accessed 10/09/2015
11. Assessment of Solar Home Systems (SHS) for Isolated Rural Communities in Vanuatu Using Project Lifecycle/Sustainability Framework (Chow .J.T, 2010),Michigan Technological University. <https://www.mtu.edu/peacecorps/programs/civil/pdfs/jack-chow-thesis-final.pdf> date accessed 15/05/15
12. Blue Sky Energy. http://www.blueskyenergyinc.com/reviews/article/what_is_a_charge_controller. Date accessed - 19/08/2014.
13. <http://www.acalbf.com/uk/Power-supplies/Batteries/p/HZY-SL-Series/00000058GM> . Date accessed - 19/08/2014.
14. OutBack FM60 – 150 Charge Controller with MPPT FLEXmax 60 <http://store.oynot.com/mpptmx60.html> . Date accessed - 20/08/2014.
15. GFX International Series-Sealed True SinewaveInverter/Charger. Available on; http://www.dcbattery.com/outback_gfx_inverters.pdf. Date accessed – 19/08/2014