

Technical University of Denmark



Economic Assessment of Network-Constrained Transactive Energy for Managing Flexible Demand in Distribution Systems

Hu, Junjie; Yang, Guangya; Xue, Yusheng

Published in:
Energies

Link to article, DOI:
[10.3390/en10050711](https://doi.org/10.3390/en10050711)

Publication date:
2017

Document Version
Publisher's PDF, also known as Version of record

[Link back to DTU Orbit](#)

Citation (APA):

Hu, J., Yang, G., & Xue, Y. (2017). Economic Assessment of Network-Constrained Transactive Energy for Managing Flexible Demand in Distribution Systems. *Energies*, 10(5), [711]. DOI: 10.3390/en10050711

DTU Library

Technical Information Center of Denmark

General rights

Copyright and moral rights for the publications made accessible in the public portal are retained by the authors and/or other copyright owners and it is a condition of accessing publications that users recognise and abide by the legal requirements associated with these rights.

- Users may download and print one copy of any publication from the public portal for the purpose of private study or research.
- You may not further distribute the material or use it for any profit-making activity or commercial gain
- You may freely distribute the URL identifying the publication in the public portal

If you believe that this document breaches copyright please contact us providing details, and we will remove access to the work immediately and investigate your claim.

Article

Economic Assessment of Network-Constrained Transactive Energy for Managing Flexible Demand in Distribution Systems

Junjie Hu ^{1,*}, Guangya Yang ^{1,*} and Yusheng Xue ²

¹ Center for Electric Power and Energy, Department of Electrical Engineering, Technical University of Denmark, Electrovej Building 325, 2800 Kgs. Lyngby, Denmark

² State Grid Electric Power Research Institute, Nanjing 210003, China; xueyusheng@sgepri.sgcc.com.cn

* Correspondence: junhu@elektro.dtu.dk (J.H.); gyy@elektro.dtu.dk (G.Y.);
Tel.: +45-93511212 (J.H.); +45-45255619 (G.Y.)

Academic Editor: Chunhua Liu

Received: 8 April 2017; Accepted: 15 May 2017; Published: 18 May 2017

Abstract: The increasing number of distributed energy resources such as electric vehicles and heat pumps connected to power systems raises operational challenges to the network operator, for example, introducing grid congestion and voltage deviations in the distribution network level if their operations are not properly coordinated. Coordination and control of a large number of distributed energy resources requires innovative approaches. In this paper, we follow up on a recently proposed network-constrained transactive energy (NCTE) method for scheduling of electric vehicles and heat pumps within a retailer's aggregation at distribution system level. We extend this method with: (1) a new modeling technique that allows the resulting congestion price to be directly interpreted as a locational marginal pricing in the system; (2) an explicit analysis of the benefits and costs of different actors when using the NCTE method in the system, given the high penetration of distributed energy resources. This paper firstly describes the NCTE-based distribution system that introduces a new interacting scheme for actors at the distribution system level. Then, technical modeling and economic interpretation of the NCTE-based distribution system are described. Finally, we show the benefits and costs of different actors within the NCTE-based distribution system.

Keywords: distribution network operations; electric vehicles; heat pumps; transactive energy

1. Introduction

It is well understood that the increasing prevalence of electric vehicles (EVs) [1] and heat pumps [2] can offer a certain degree of flexibility and can potentially be the critical components in the operation of a smart grid [3–5], since the flexible demands can be used to balance the power systems and defer the network upgrading. For example, an electric car adapts its charging patterns to balance fluctuating wind power or solar energy levels, a heat pump defers its energy demand because a power transformer is overloaded. Many studies have been proposed to show the benefits as well as the control method to integrate flexible demands and power systems needs. In this paper, we focus on how electric vehicles and heat pumps can be integrated to address potential congestion problems, which include power transformer overloading and voltage drops.

In general, three control strategies are widely proposed in the literature to integrate electric vehicles and heat pumps into a distribution network's operation, including centralized control [6], price-based control [7], and transactive energy [8]. In centralized control, the distribution network operator (DNO) defines and sends technical constraints or allocated capacity to aggregators, who use the information defined by the DNO in their scheduling problem. For example, in [6], a scheduling

problem involving EV owners, EV-aggregators, and a DNO is analyzed. The approach requires a complex interaction between the DNO and the EV-aggregators. In each interaction, the aggregator gets a specific grid constraint from the DNO and adds it in the EV charging cost minimization problem; the interaction stops when the grid congestion and voltage problems are solved. In price-based control [7], the DNO will foresee the potential overloading in certain periods and publish the congestion price in advance to the aggregator, who will then make optimal power schedules for EVs and heat pumps. Although straight-forward and easy to implement, the model [7] brings about the risk of causing new peaks in the grid due to the unconfirmed power schedule of aggregators to the DNO.

Both of the methods above lack a process of negotiation between the aggregators and the network operators; instead, transactive energy shows its advantages in managing distributed energy resources due to its decentralized decision-making and transparent characteristics [9]. Transactive energy is defined as “a set of economic and control mechanisms that allows the dynamic balance of supply and demand across the entire electrical infrastructure using value as a key operational parameter” [10], and has been successfully demonstrated in several projects in the US and Europe. Transactive energy (TE) has been used in several articles [11,12] to address the congestion issue caused by EVs. In [11], transactive energy was used for the charging of electric vehicles that incorporated distribution transformer and voltage constraints. A hierarchical multi-agent structure was used in the study to implement the transactive energy scheme that consists of three types of agents, i.e., auctioneer, substation, and EV device agent. The substation agent collected the bid functions of all the connected EV device agents in a low-voltage network, and then sent the bid function to the auctioneer agent who defined the equilibrium price. Furthermore, the substation agent also ensured that the possible equilibrium price does not violate grid constraints. In [12], the authors develop a multiple-period network-constrained transactive energy (NCTE) method to integrate electric vehicles into the power distribution system, in which different stakeholders’s interests and operational constraints including DNO, aggregator, and EV owners are specifically considered. DNO interacted with the aggregators to find the power consensus on each bus of the network under the NCTE method.

Note that in transactive energy application, suggestions have been made in the literature of how to handle congestion prices utilized in the transactive energy method in real practice. In [11], the authors assumed that the customers are not charged at the congestion price in the transactive energy, instead, the price is interpreted as a control signal to resolve the problem. Alternatively, it is argued in [12] that congestion price at the distribution system level should have real economic incentive. However, the argument and the elaboration on the congestion price are not further described in [12].

This study follows up on our recent work [12] and extends the network-constrained transactive energy method presented therein with two new contributions. A major contribution is related to the reformulation of the retailer’s scheduling and interaction problems (retailer interacts with DNO) which makes the resulting congestion price directly associated with the marginal cost of electricity retailing. In [12], the retailer’s scheduling and interaction problem was formulated into two stages. In contrast, here we integrate the scheduling and interaction problem into one step, which is easier for the retailer to implement. Two additional extensions are: (1) the inclusion of a heat pump model which is another important flexible demand at the distribution system level; and (2) this study also discusses practical implications of two different congestion price-updating processes in the NCTE method. The second contribution of the paper is the explicit discussion of the benefits and costs of different stakeholders within the transactive energy system, which is illustrated through the Danish context but a similar idea can be applied to other frameworks.

2. A Network-Constrained Transactive Energy-Based Distribution System

Figure 1 presents a distribution system where the network-constrained transactive energy method is applied to schedule and operate the connected distributed energy resources; although the focus of this paper is scheduling, the method is also possible for real-time control with certain adjustments [13]. In this system, it is assumed that in addition to providing electricity service to

conventional households/loads, retailers will also manage electric vehicles and heat pumps to explore the benefits of their flexibilities which can minimize operational costs. Note that nowadays the energy dispatch method is done according to the spot market price (i.e., the retailers aim to procure more electricity when the spot price is low). The state of the distribution network is not considered, which means a conflicting situation might happen due to the new high power loads. For example, retailers who aim to procure the energy from the spot market in a lower price period, while the procured energy/power brings operational challenges to distribution networks. In order to integrate distributed energy resources, such as electric vehicles and heat pumps smoothly into the distribution network, novel control relationships are needed for the distribution system. It is envisioned that in this NCTE-based distribution system, retailers will have new needs/functions to handle such new flexible loads. Besides, the retailers will coordinate their schedules and operations with DNOs. In this study, the DNO is a non-profit organization, and is responsible for the safe operation of the distribution network, providing a power distribution service to public.

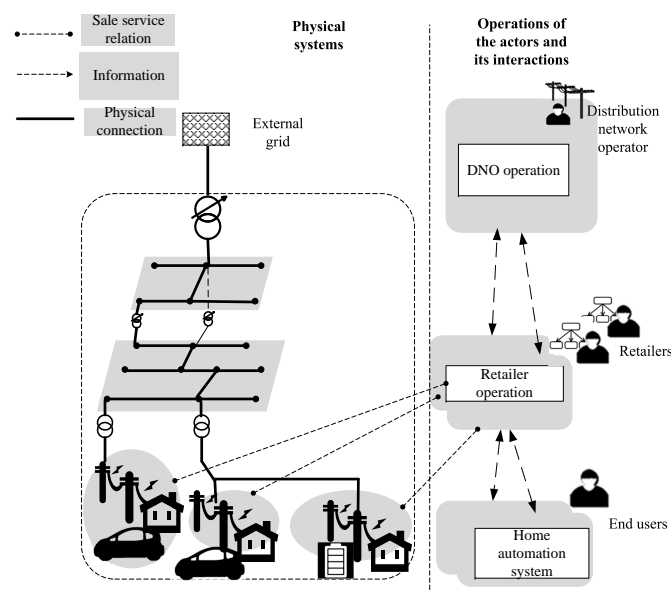

Figure 1. An overview of the network-constrained transactive energy-based distribution system. DNO: distribution network operator.

The overall operational sequence diagram of the NCTE-based distribution system is presented in Figure 2. As shown in the figure, besides the DNO, retailers, and end-users, a new actor named distribution-independent system operator (DISO) is proposed in this system to coordinate DNO and retailers' interests and operational conflicts. The argument for having a DISO in the system is described in [12]; the reader is referred there for detailed explanation. Firstly, the end-users will share their demand information such as EV's driving pattern and comfort temperature zone of the household to the retailers. Then, retailers will make a day-ahead schedule based on the energy requirements of end-users and the predicted spot price. These initial day-ahead schedules will be shared to the DNO. After receiving the initial schedule of each retailer, the DNO will firstly run a power flow calculation to evaluate the voltage and power transformer conditions. If the network condition is within the safe boundary, the schedule will be accepted by the DNO; otherwise, the DNO and retailers will coordinate with the DISO to resolve the mismatch. In this interaction, retailers could send the same initial schedule to the DISO, and the DNO will inform their allowable capacity to the DISO. After receiving the DNO and retailer information, the DISO will use price to coordinate the operational interests and constraints of the DNO and retailers. At the last step of the coordination, the congestion price will be issued to

the DNO and retailers, which also implies that final power is consented between DNO and retailers. The final schedule will be sent to end-users.

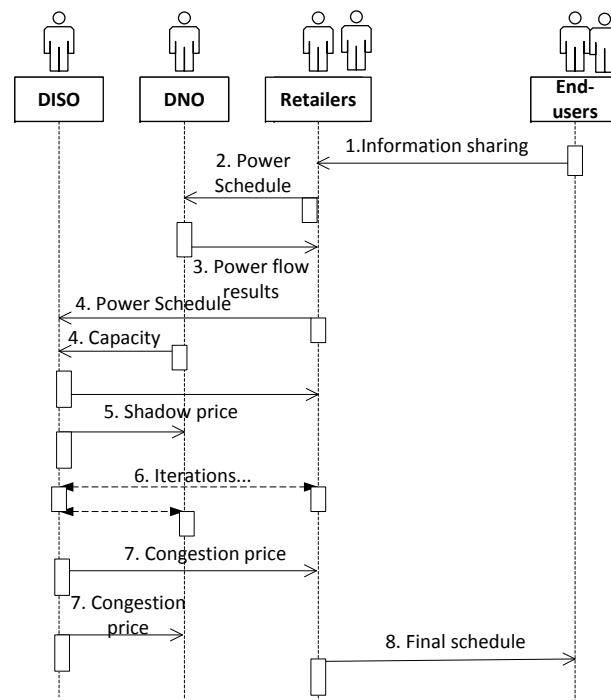

Figure 2. Overall operational sequence diagram of the transactive distribution system. DISO: distribution-independent system operator.

To support the overall operational sequences, Section 3.1 introduces the method for generating the day-ahead schedule of retailers; specifically, the EVs' and heat pumps' power profiles are optimized based on their energy requirements and the predicted day-ahead spot price. Besides, in Section 3.1, the DNO's available capacity is calculated. The overall social welfare maximization problem is presented in Section 3.2. The implementation of the sequences here needs the optimal decision making of each actor, which is illustrated in Section 3.2. In terms of the congestion price, Section 3.3 discusses how to use it in reality.

3. Mathematical Modeling and Its Economic Interpretation

3.1. Retailer's Day-Ahead Scheduling and DNO's Day-Ahead Capacity Allocation

In general, loads can be classified into three main categories according to their response to price: critical loads, interruptible loads, and deferrable loads [14]. A load is deferrable if the loads can be rescheduled by the users and the load consumes a minimum amount of power over a given interval of time. In this study, we consider EVs and heat pumps (HP) to be deferrable/interruptible loads that can be optimally scheduled by the retailers. In addition, the retailer also buys the energy for critical load for users.

For each retailer Rtl , the aggregated power per bus b per time slot i is calculated according to (1):

$$P_{Rtl}^{Lmit}(i, b) = \sum_{j \rightarrow b} P_{j,i,b} + \sum_{m \rightarrow b} P_{m,i,b} + P_{c,i,b} \quad (1)$$

where $P_{j,i,b}$ and $P_{m,i,b}$ are optimal EV and HP power schedule which is calculated from EV optimization problem (A2) and HP optimization problem (A4), described in Appendix A.1, respectively, where network conditions are not considered. $j \mapsto b, m \mapsto b$ denotes electric vehicles indexed by j and

heat pumps indexed by m connected at bus b . Note that the initial schedule $P_{Rhl}^{Init}(i, b)$ will be shared to the DNO, thus the bus information is also included in the aggregated power formulation (1).

When receiving the initial power schedule from different retailers, the DNO checks the network conditions and identifies potential problems. If the initial power schedule cause problems, the DNO and retailers will coordinate with the DISO to resolve the conflicts. The detailed formulation regarding how DNO plans the available capacity is presented in Appendix A.2.

3.2. The Social Welfare Maximization Problem and Its Distributed Implementation

To minimize the cost to retailers/end-users and to maximize the interests of the DNO, a social welfare maximization problem is formulated in Appendix A.3. To solve the optimization problem, a decomposition method is applied that can divide the problem into sub-optimal problems, which not only mathematically reduces the problem complexities, but also provides a way of distributing the right of decision-making to each actor in the network. The suboptimal problems include (1) retailers' and (2) DNO's optimization problem, coordinated by the DISO in (3) of this section.

(1) Each retailer's re-minimization at step ω

EVs' and heat pumps' rescheduling problems are described separately. EV charging's rescheduling problem is formulated as:

$$\min \left\{ \sum_{i=1}^{N_T} \sum_{j=1}^{N_E} (\Phi_{j,i,b} + \beta_{j,i,b} \cdot P_{j,i,b}) P_{j,i,b} t_{j,i} + \sum_{i=1}^{N_T} \sum_{j=1}^{N_E} \lambda_{\omega}(i, b, j) P_{j,i,b} \right\} \quad (2)$$

subject to EV battery energy constraint and EV charger constraint, where detailed formulas are listed in (A3) for brevity, where the decision variable $P_{j,i,b}, \lambda_{\omega}(i, b, j)$ has three dimensions, even though the lambda is only associated to bus and time. Since each EV j will be attached to one bus b at time i , thus $\lambda_{\omega}(i, b, j)$ has three dimensions. It also means EVs attached to the same bus will have same lambda value.

HPs' power schedule re-optimization problem is formulated as:

$$\min \left\{ \sum_{i=1}^{N_T} \sum_{m=1}^{N_{HP}} (\Phi_{m,i,b} + \beta_{m,i,b} \cdot P_{m,i,b}) P_{m,i,b} t_{m,i} + \sum_{i=1}^{N_T} \sum_{m=1}^{N_{HP}} \lambda_{\omega}(i, b, m) P_{m,i,b} \right\} \quad (3)$$

subject to the constraints of heat transfer and thermal balances, the relation between thermal energy and electricity power, room temperature comfort zone, and heat pump operational conditions. These constraints are detailed in (A5)–(A9) in the Appendix, where the decision variable is $P_{m,i,b}; \lambda_{\omega}(i, b, m)$ has similar interpretation as $\lambda_{\omega}(i, b, j)$ in the EV case.

(2) DNO's re-minimization at step ω

$$\min \left\{ a \cdot \sum_{i=1}^{N_T} \sum_{b=1}^{N_B} \left(P_{DNO}(i, b) - \sum_{Rhl=1}^{n_F} P_{Rhl}^{Init}(i, b) \right)^2 + d \cdot P_{Loss} - \sum_{i=1}^{N_T} \sum_{b=1}^{N_B} \lambda_{\omega}(i, b) \cdot P_{DNO}(i, b) \right\} \quad (4)$$

subject to (A11). To solve problem (4) and get the solution of the optimization variable $P_{DNO}(i, b)$, we use YALMIP [15] (a toolbox for modeling and optimization in MATLAB, Natick, MA, USA), and MATPOWER [16], a MATLAB power system simulation package.

(3) DISO: Lagrangian multiplier updating for step $\omega + 1$

Note that depending on the constraint (A13) in Appendix A.3, if the sign \doteq represents \leq , the following method will be used to update the λ :

$$\lambda_{\omega+1}(i, b) = \max \left\{ \lambda_{\omega}(i, b) + \alpha_{\omega} \cdot \left(\sum_{Rtl=1}^{n_F} P_{Rtl}(i, b)^{\omega} - P_{DNO}(i, b)^{\omega} \right), 0 \right\} \quad (5)$$

If the sign \doteq means $=$, the following method will be used to update the λ :

$$\lambda_{\omega+1}(i, b) = \lambda_{\omega}(i, b) + \alpha_{\omega} \cdot \left(\sum_{Rtl=1}^{n_F} P_{Rtl}(i, b)^{\omega} - P_{DNO}(i, b)^{\omega} \right) \quad (6)$$

Note that the difference between (5) and (6) is that a negative value of lambda is allowed in (6). Mathematically, these two approaches are applicable; however, their implications to the DNO and retailers are different, which will be examined in the case study section.

In the above Lagrangian multiplier updating problem, $P_{Rtl}(i, b)^{\omega}$ is the sum of the solution of problems (2) and (3), and $P_{c,i,b}$; i.e., $P_{Rtl}(i, b)^{\omega} = \sum_{j \rightarrow b} P_{j,i,b}^{\omega} + \sum_{m \rightarrow b} P_{m,i,b}^{\omega} + P_{c,i,b}$. $P_{DNO}(i, b)^{\omega}$ is the solution of (4), $\alpha_{\omega} \in R$ denotes the step size and can be chosen as $\alpha_{\omega} = \alpha$, which is a positive constant, and with the choice, the convergence is guaranteed [17]. Note that λ is converged at each bus in each time slot. A simple step size is chosen here to update the λ , but as discussed in [17], some heuristic approaches can be performed to improve the convergence speed.

3.3. Economic Interpretation of the Congestion Price and Its Implication for the DNO Business Model

In this section, we first introduce the current electricity retail price components based on a Danish case, followed by the suggestion to incorporate the converged congestion price (i.e., $\lambda_{\omega}^*(i, b)$) into the retail price. In the Danish electricity system [18,19], the electricity price is composed of several elements: the energy price/supply tariff, taxes and PSO (public service obligation) element, transmission and distribution grid tariff, and value-added tax, which is shown in Figure 3. Household customers in Denmark pay a comparatively high flat price for electricity; i.e., 2.2 DKK/kWh. As indicated in the figure, in Denmark, the cost of energy represents only around 20% of the overall retail price, while the energy taxes are three times the European average [20]. With this flat rate, the end-user might not have an interest in optimizing their power usage if the overall energy is the same; however, the retailer has an interest in optimizing the energy schedule of their end-users to minimize the supply tariff. Note that the way in which the retailer persuades end-users to let their assets including EVs and heat pumps be optimized is not discussed in this study, but will be addressed in future work.

The distribution grid tariff of the retail price comes from providing access and services in the distribution network on medium- and low-voltage levels. Distribution network tariffs are decided by local DNOs. The tariffs shall be adequate, objective, and non-discriminating. The DNOs determine the tariffs according to a benchmarking method. Furthermore, these tariffs are regulated by the Danish Energy Regulatory Authority. The distribution grid tariff normally consists of two elements: a monthly (or quarterly) grid access charge, and a consumption-based local grid tariff. The local grid tariff is fixed in a quarter time and it is based on average costs. The costs cover for grid losses in the distribution grid, operation and maintenance of the medium/low voltage grid, depreciation of assets (except meters), cost of decommissioning of infrastructure (overhead lines), insurance premiums, and energy-saving activities.

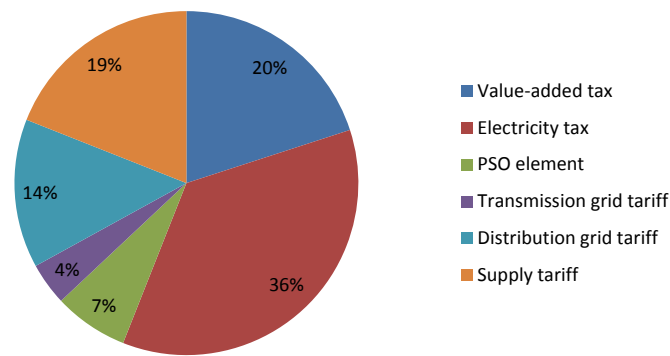

Figure 3. Composition of the residential electricity price, simplified for a consumption of a normal household with 4000 kWh/y, average for 2012 [19]. PSO: public service obligation.

As seen in Figure 3, the distribution tariff is around 14% of the retail price. It is suggested in this study that the congestion price could be combined with the distribution grid fee, where the tariff will be proportional to the congestion level of the grid. In other words, the tariff can be more dynamic in the framework of an NCTE-based distribution system. Without transactive energy, the distribution tariff will certainly increase due to the network upgrading cost, which will eventually be passed to the end users with an increased bill. This situation is neither favorable nor efficient for both grid operators and end users. With the transactive distribution system, the peak power can be avoided if the real-time power profile of EVs and heat pumps follows the schedules.

Note that after the NCTE control, the congestion is resolved; therefore, it is suggested here that the congestion price should not be used for retailers if the real-time power profiles follow the schedule (i.e., the retailers will be charged the normal price). However, if the real-time power profile deviates from the schedule in some situations, we suggest that the deviated amount should be charged by the congestion price. Due to the stiffness of the constraints in optimization, the resulted price could be extreme, which largely distorts the effect of spot market price signal. This means that the schedule of the retailers can change drastically given the price generated through transactive energy. Therefore, we do not recommend the direct use of the price quantity; instead, it should be made in proportion to the other electricity charges to sufficiently reflect the situation of the grid. Overall, the retailers will be charged a bit more since their initial optimal schedules have been shifted to other time period, which can be compensated by the DNO, who receives the ancillary service from retailers. In terms of end-users, their cost remains the same as before but could be remunerated because their assets are controlled by retailers. Furthermore, for DNO, the losses, the infrastructure cost, and the asset depreciation cost can be reduced. Overall, the social welfare is maximized within this NCTE-based distribution system. The quantification of this impact will be addressed in future work.

4. Case Studies

A representative Danish distribution grid is illustrated in Figure 4, where 72 households are connected to the feeders: 51 households are attached to the left branch and 21 households are located on the right side of the network. For the parameters used in the system, a time series conventional load is assumed to be known by the distribution system operators. With the base load, the DNO can calculate the base voltage (i.e., the U_0 in (A11) per bus). In all time slots, the power transformer capacity allocated to EVs and HPs of two retailers is 50 kW, the minimum voltage U_{Min} per bus is assumed to be 0.90 p.u. The initial Lagrangian multipliers are assumed to be zero per bus in all time slots, and are updated per iteration to the retailers and the DNO. A constant step size ($\alpha_\omega = 0.05$) is chosen for the Lagrangian multiplier update. The values of a and d are 0.1 and 300, respectively. Note that the values of a and d can influence the control performance and the cost of both DNO and retailers. Therefore, the values should be agreed upon based on negotiation between the DNO and the retailers.

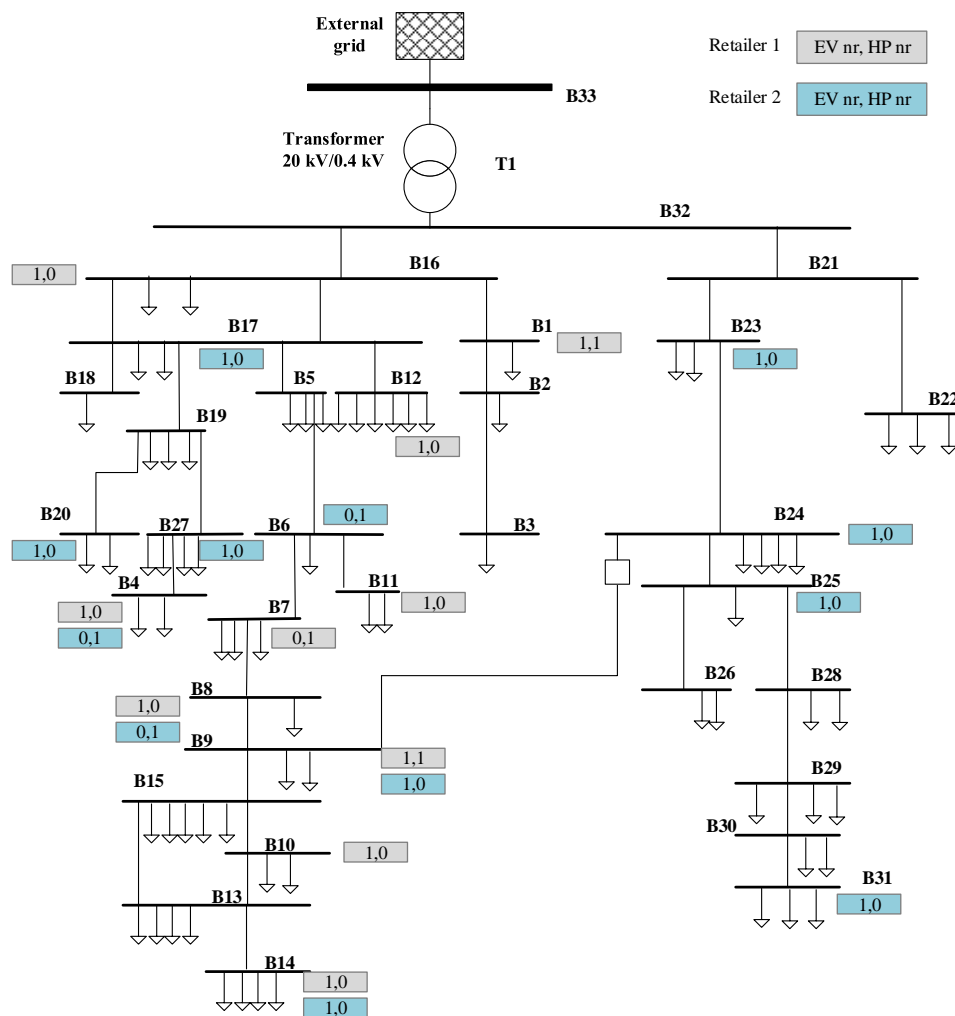

Figure 4. A representative Danish distribution network with base load, electric vehicle (EV), and heat pump (HP) connected. Gray blocks indicate Retailer 1's EV number and HP number under each bus, and the blue blocks indicate Retailer 2's EV number and HP number under each bus.

In terms of EVs, all EVs are affiliated to either *Retailer 1* (Rtl_1) or *Retailer 2* (Rtl_2). The number of EVs operated by Rtl_1 and Rtl_2 is nine. The hourly predicted day-ahead market price from 00:00 to 24:00 is assumed to be known to the retailers, and the price is shown in Figure 5. The electricity price assumed here is drawn from the real electricity price from NordPool spot market. The price will be used for generating EV charging and HP power schedule. The scheduling period considered in this case is from 16:00 to 06:00, while a whole-day scheduling period is considered for HPs. In both cases, an hourly interval is used.

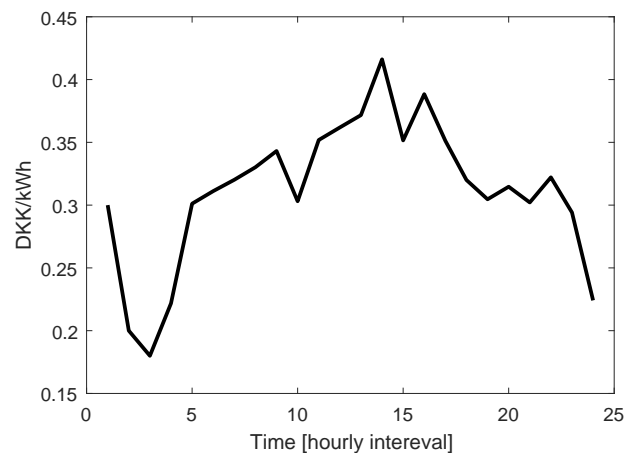

Figure 5. An electricity energy price example from NordPool.

For other parameters in EV charging:

- Battery capacity E_{cap} is set to 24 kWh;
- SOC_0 is set to 0.2 of the battery capacity, SOC denotes state of charge;
- SOC_{max} is set to 100% of the battery capacity;
- Maximum charging power is limited to 3.7 kW which fits with the Danish case (16 A, 230 V connection).

Similarly, heat pumps are also operated either by Rtl_1 or Rtl_2 as shown in Figure 4; the key heat pump information is listed as follows. Other parameter values are not listed for simplicity, but can be accessed by addressing the authors:

- Coefficient of performance (COP) of HP is set to 2.3;
- Min temp. of the house is 20°;
- Max temp. of the house is 24°;
- Maximum power is limited to 4 kW.

Note that the control performance of the transactive distribution system was demonstrated in [12]; here the results focus on cost analysis. We show different costs introduced by having negative lambda value and nonnegative lambda value in the transactive distribution system. Table 1 shows the energy cost (calculated based on energy spot price) of two retailers before and after the transactive energy. It is seen that the cost difference is small for two retailers when adapting the two different lambda cases.

Table 1. Overview of total energy costs for EVs and HPs of two retailers. TE: transactive energy.

Case	Retailer	Total Costs before TE	Total Costs after TE
With negative prices	Rtl_1	85.16 DKK	88.00 DKK
	Rtl_2	85.16 DKK	85.89 DKK
Without negative prices	Rtl_1	85.16 DKK	87.67 DKK
	Rtl_2	85.16 DKK	87.64 DKK

However, as indicated in Table 2, the network losses and the required energy are different for the different lambda cases. When the lambda is allowed to have negative price, the network losses and energy after transactive energy are larger than the one calculated from the nonnegative price case. At first glance, the simulation result here appears to conflict with the one presented in [21], where the DNO can benefit more from the transactive energy system when the price is allowed to have negative

price. It is found and argued there that DNO has smaller losses in the negative-price case, as the DNO and retailers have more iterations to find the global optimum, the power information exchange between the DNO and the retailers at one bus does not stop when the value of lambda is negative. As illustrated in Figures 6 and 7 of this study, the consented power profile of DNO and retailers at buses 2 and 8 in time slot 3 are plotted. Compared to Figure 6, in Figure 7, the DNO's power is driven to zero under the negative price scheme (note that the base load is not plotted in the figure).

Table 2. Overview of network conditions.

Case		Network Losses (MWh)	Energy (MWh)	Loss Ratio (%)	Min. Voltage (pu)
With negative prices	Before TE	0.1458	2.8792	5.07	0.8967
	After TE	0.1454	2.8854	5.04	0.9022
Without negative prices	Before TE	0.1458	2.8792	5.07	0.8967
	After TE	0.1448	2.8768	5.03	0.9081

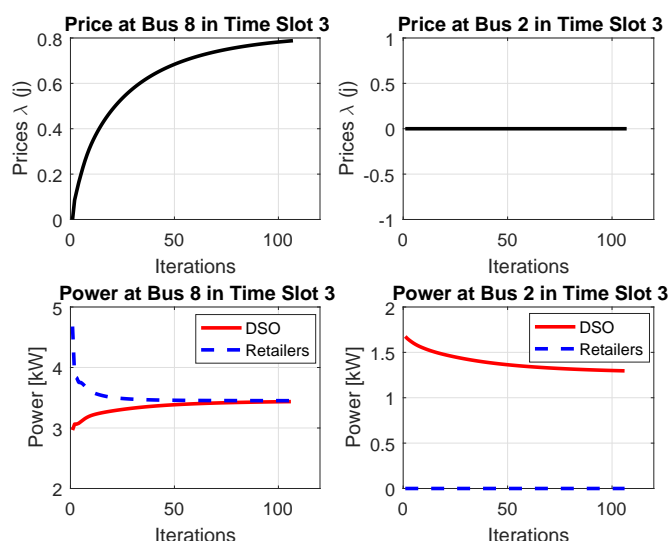

Figure 6. Development at bus 8 and bus 2, where the congestion price updating method of (5) is used.

To determine the reason for this apparently conflicting result, we look into retailers' power profiles (i.e., heat pump and electric vehicle power profiles before and after transactive energy). The simulation shows that the overall EV power schedules do not change before and after transactive energy—the energy is only shifted in different time periods; this is not the case for the heat pump model. It is observed that in the negative-price case where the aggregated heat pump power of Retailer 1 (sum of the HPs in all time slots) changes from 127.65 kWh to 135.13 kWh, which is a result of the negative price generated on bus 1, shown in Figure 7. The increased energy of heat pumps is the reason for the higher losses in the negative-price allowed case. In fact, negative congestion price indicates the encouragement of DNO towards electricity consumption for that period at that specific location. In Figure 8, the power profiles of one heat pump of Retailer 1 at bus 1 (before and after TE case) is shown, where it is clearly demonstrated that power increases due to the decreased congestion price.

Note that in Table 1, we only calculate the energy cost of the retailers; it is shown that the total cost after transactive energy (TE) is higher than the case before TE. As argued in Section 3.3, the increased energy bills could be compensated by the DNO.

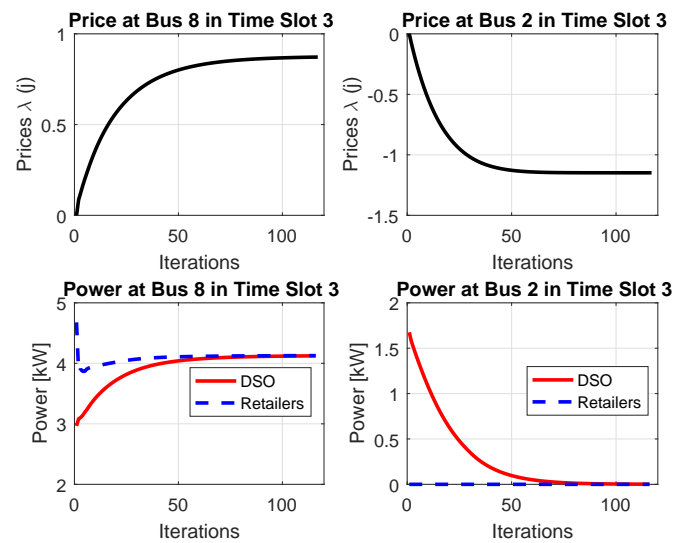

Figure 7. Development at bus 8 and bus 2, where congestion price updating method of (6) is used.

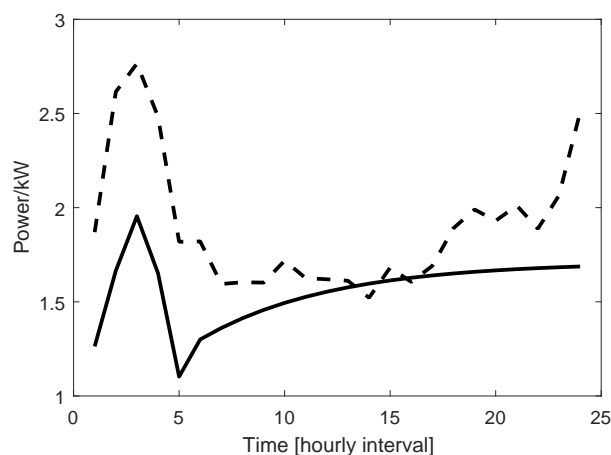

Figure 8. Power usage of one heat pump of Rtl_1 at bus 1. Solid line represents the power before TE, dashed line shows the power after TE.

5. Discussion and Conclusions

This study presents a network-constrained transactive energy-based distribution system for distributed energy resource planning and operation under the existing electricity market framework. Specifically, the economic perspective of a transactive energy-based distribution system are discussed. It is shown that the transactive energy could leverage multiple value streams to distribution system operators, retailers, and end-users, which makes it cost-effective to deploy the transactive infrastructures, compared to the normal distribution system operational approach. Furthermore, it is worth noting that unlike the flexibility of electric vehicles, the overall energy consumption of heat pumps may change a little when their flexibilities are used in multiple-time periods; this brings additional complexity to the transactive energy-based distribution system. Last but not least, it is recommended that a nonnegative lambda updating method should be used in transactive energy. This is because if the lambda is allowed to go negative, the original schedule of heat pumps from the retailers can be changed significantly, which is not favorable for the retailer. However, if lambda is only allowed to be positive, then the iteration between the DNO and the retailers will stop if the retailers' initial schedule causes no congestion.

In terms of future research, stochastic features of loads and the uncertainty of EV charging behaviors should be studied to evaluate transactive energy performances. In addition, a future distribution system scenario featured with high penetration of renewable generation such as photovoltaics and storage technologies should be analyzed within this transactive distribution system, advanced decision-making and control function at household-level, and their interactions with retailers and DNOs should be further analyzed.

Acknowledgments: This work is supported by a Danish ForskEL Project "A Live PV Testing Platform for Larger Adoption" Project (ForskEL Program, Grant Number: 12421) and the Danish EUDP Project "PV + Storage-Operation and Economics" (EUDP17-1, Grant Number: 12551).

Author Contributions: Guangya Yang and Junjie Hu conceived the research idea and designed the simulation setup; Junjie Hu performed the simulation and wrote the paper. Guangya Yang and Yusheng Xue proofread the paper.

Conflicts of Interest: The authors declare no conflict of interest.

Nomenclature

Indices

i	Index of time slot in a scheduling horizon, $i = 1, \dots, N_T$.
j	Index for the number of electric vehicles under each retailer's operation, $j = 1, 2, \dots, N_E$.
m	Index for the number of heat pumps under each retailer's operation, $m = 1, 2, \dots, N_{HP}$.
b	Index of the bus of the network, $b = 1, \dots, N_B$.
l	Index of the branches of the network, $l = 1, \dots, N_L$.
ω	Index for the iterations.
Rtl	Index of the number of retailers within a distribution network area, $Rtl = 1, \dots, N_F$.

Electric Vehicle-Related Decision Variable and Parameters

$P_{j,i,b}$	Decision variable of individual EV j at time slot i , bus b .
$SOC_{0,j}$	Initial SOC of individual EV.
$SOC_{Max,j}$	Requested/targeted maximum SOC of individual EV at the end of the charging period.
$P_{Max,j}$	Maximum charging rate of individual EV.
$E_{cap,j}$	Capacity of the battery of the EV.

Heat Pump-Related Decision Variable and Parameters

$P_{m,i,b}$	Decision variable of individual heat pump m at time i , bus b .
$P_{Min,m}, P_{Max,m}$	Minimum and maximum power of heat pump.
T_i^a	House inside air temperature at time i .
$T_{Min,m}, T_{Max,m}$	Maximum and minimum temperature setting point.
T_i^s	House envelope temperature.
T_i	Ambient temperature.
Q_i	Thermal energy input to the house.
COP	Coefficient of performance, active power to thermal energy.
C_a, C_s	Heat capacity of indoor air and inner walls.
k_1, k_2, k_3	Thermal conductance between the building interior and the ambient air, thermal conductance between interior and the building envelop, and thermal conductance between the building envelop and the ambient air.
S_i	The heat input from solar radiation.

DNO-Related Decision Variable and Parameters

a, d	Weighting factors.
$P_{c,i,b}$	Conventional load profiles, which is assumed to be known.
$P_{DNO}(i, b)$	Optimization variable and its physical meaning is the desirable power of DNO for EVs charging, excluding the base load profile.

n_F	Number of retailers which have EVs, HPs attached in bus l .
A	Full bus incidence matrix, $N_{Line} \times N_B$, associated to the reference direction of branches. If bus m is the initial node of branch $[m, n]$, $A(m, n) = 1$, else $A(m, n) = -1$. Note that the matrix is not necessary a square matrix.
N_{Line}	Number of branches.
P_{Trans}^{Max}	Power transformer capacity for all the aggregators; for example, it can be estimated by the DNO after deducting the conventional loads.
$U_0(i, b)$	The initial voltage of the buses of the network.
$U_{Min}(i, b)$	The minimum allowable voltage of the buses of the network.

Other Variable, Indices, Parameters

Φ_i	Predicted day-ahead electricity market price vector.
$P_{Ril}^{Init}(i, b)$	Initial aggregated schedule of retailer at time slot i of bus b .
β_i	Price sensitivity coefficient that reflects flexible demand's influence on the day-ahead spot price.

Appendix A

Appendix A.1. Retailer Day-Ahead Scheduling Model

As discussed in [7], the flexible demand might bring a slight change to the spot price. To reflect the change, a model is used in [7] to predict the spot price:

$$y_i = \Phi_i + \beta_i * P \quad (A1)$$

Furthermore, it is argued that this modification will reduce the degeneracy problem when DNO is interacting with aggregators.

In this study, we combine the model presented in [7,12] and use the following formulas to characterize the EV charging cost minimization problem:

$$\min \left\{ \sum_{j=1}^{N_E} \sum_{i=1}^{N_T} (\Phi_{j,i,b} + \beta_{j,i,b} * P_{j,i,b}) P_{j,i,b} t_{j,i} \right\} \quad (A2)$$

subject to:

$$\begin{cases} SOC_{0,j} \cdot E_{cap,j} + \sum_{i=1}^{N_T} P_{j,i,b} t_{j,i} = SOC_{Max,j} \cdot E_{cap,j} \\ 0 \leq P_{j,i,b} \leq P_{Max,j} \end{cases} \quad (A3)$$

where the objective is to minimize the cost of EVs' energy consumption. Note that here $P_{j,i,b}$ has three dimensions, but in practice, we only optimize P_i for individual EV j attached to known bus b . So, in this stage, the EV aggregator gets the optimal value of P_i for each EV j at bus b . In addition, the first constraint of (A3) means that the energy to be charged should be equal to the requested energy at the end of the charging period for each electric vehicle. The second constraint represents that the charging rate is less than or equal to the maximum power rate of a charger.

In terms of heat pumps' optimal power scheduling, the following model is used [7]:

$$\min \left\{ \sum_{m=1}^{N_{HP}} \sum_{i=1}^{N_T} (\Phi_{m,i,b} + \beta_{m,i,b} * P_{m,i,b}) P_{m,i,b} t_{m,i} \right\} \quad (A4)$$

subject to the following constraints, $\forall i \in N_T$:

$$Q_i + S_i - k_1(T_i^a - T_i) - k_2(T_i^a - T_i^s) = C_a(T_i^a - T_{i-1}^a), \forall m \quad (A5)$$

$$S_i + k_2(T_i^a - T_i^s) - k_3(T_i^s - T_i) = C_s(T_i^s - T_{i-1}^s), \forall m \quad (A6)$$

$$Q_i = P_{m,i,b} * COP \quad (A7)$$

$$T_{Min,m} \leq T_i^a \leq T_{Max,m} \quad (A8)$$

$$P_{Min,m} \leq P_{m,i,b} \leq P_{Max,m} \quad (A9)$$

where the first two constraints characterize the heat transfer and thermal balances. As shown in (A7), the coefficient of performance (COP) is used to formulate the relation between thermal energy and the active power. In addition, in (A8), the temperature is assumed to be within a minimum and maximum degree. We also set up heat pump operational conditions in (A9).

Appendix A.2. DNO Day-Ahead Capacity Allocation Model

For the DNO, the objective is to track and regulate the power schedule from retailers while respecting the operational constraints such as the transformer thermal capacity and the voltage limitations of buses, as well as to minimize the network losses:

$$\min \left\{ \sum_{i=1}^{N_T} \sum_{b=1}^{N_B} \left(P_{DNO}(i,b) - \sum_{Rtl=1}^{n_F} P_{Rtl}^{Init}(i,b) \right)^2 + d \cdot P_{Loss} \right\} \quad (A10)$$

subject to:

$$\begin{aligned} \sum_{b=1}^{N_B} P_{DNO}(i,b) &\leq P_{Trans}^{Max}(i) \\ U_0(i,b) + \Delta U(i,b) &\geq U_{Min}(i,b) \end{aligned} \quad (A11)$$

In (A11),

$$\begin{aligned} P_{loss} &= \sum_{i=1}^{N_T} \sum_{l=1}^{N_{Line}} \left(\frac{P_{line,l}^2(i) + Q_{line,l}^2(i)}{V^2} \right) R_l \\ P_{line}(i,l) &= (A \cdot A^T)^{-1} \cdot A \cdot (P_c(i,b) + P_{DNO}(i,b)) \end{aligned}$$

where $P_{loss} = \sum_{i=1}^{N_T} \sum_{l=1}^{N_{Line}} \left(\frac{P_{line,l}^2(i) + Q_{line,l}^2(i)}{V^2} \right) R_l$ can be approximated as $P_{loss} = \sum_{i=1}^{N_T} \sum_{l=1}^{N_{Line}} P_{line}^2(i,l) R_l$, since Q is usually small in a low voltage network, and as long as the voltage is close to nominal. $\Delta U(i,b)$ is calculated from the following simplified equation [22]:

$$\begin{bmatrix} \Delta P \\ \Delta Q \end{bmatrix} = \begin{bmatrix} \frac{\partial P}{\partial \Theta} & \frac{\partial P}{\partial U} \\ \frac{\partial Q}{\partial \Theta} & \frac{\partial Q}{\partial U} \end{bmatrix} \begin{bmatrix} \Delta \Theta \\ \Delta U \end{bmatrix}$$

Denote J the load flow Jacobian from the last iteration,

$$J = \begin{bmatrix} \frac{\partial P}{\partial \Theta} & \frac{\partial P}{\partial U} \\ \frac{\partial Q}{\partial \Theta} & \frac{\partial Q}{\partial U} \end{bmatrix}$$

then the voltage increment can be calculated by the injection increment times the reverse of the Jacobian, as shown below:

$$\begin{bmatrix} \Delta \Theta(i,b) \\ \Delta U(i,b) \end{bmatrix} = J^{-1} \begin{bmatrix} \Delta P(i,b) \\ \Delta Q(i,b) \end{bmatrix} = J^{-1} \begin{bmatrix} P_{DNO}(i,b) \\ 0 \end{bmatrix}$$

Here, we assume the reactive power injection increment is zero. Θ means voltage angle, and it is not considered in this study. Thus, we have:

$$\Delta U(i, b) = J_{21}^{-1} \cdot P_{DNO}(i, b)$$

where J_{21}^{-1} means only a submatrix of J^{-1} is used.

Appendix A.3. Social Welfare Maximization Model

The social welfare maximization problem is formulated as follows, which includes the objective functions and constraints of retailers and DNO:

$$\min \left\{ \sum_{Rtl=1}^{N_F} \left(\sum_{j=1}^{N_T} \sum_{i=1}^{N_E} (\Phi_{j,i,b} + \beta_{j,i,b} * P_{j,i,b}) P_{j,i,b} t_{j,i} + \sum_{m=1}^{N_{HP}} \sum_{i=1}^{N_T} (\Phi_{m,i,b} + \beta_{m,i,b} * P_{m,i,b}) P_{m,i,b} t_{m,i} \right) + a \cdot \sum_{i=1}^{N_T} \sum_{b=1}^{N_B} \left(P_{DNO}(i, b) - \sum_{Rtl=1}^{n_F} P_{Rtl}^{Init}(i, b) \right)^2 + d \cdot P_{Loss} \right\} \quad (A12)$$

subject to (A3), (A5)–(A9), (A11), and the one as follows:

$$\sum_{Rtl=1}^{n_F} P_{Rtl}(i, b) \doteq P_{DNO}(i, b) \quad (A13)$$

where the optimization variables of this optimization problem are $P_{j,i,b}$, $P_{m,i,b}$, and $P_{DNO}(i, b)$. The constraint (A13) implies that the sum of the new optimal power of aggregators should be equal (or less than or equal) to the new optimal power of the DNO.

Let $\lambda(i, b)$ denote the Lagrange multiplier corresponding to the constraint of (A13), and keep the rest of the constraints implicit, so the Lagrangian function for (A12) is:

$$\begin{aligned} L \left(\lambda(i, b), P_{j,i,b}, P_{DNO}(i, b) \right) = & \sum_{Rtl=1}^{N_F} \left(\sum_{i=1}^{N_T} \sum_{j=1}^{N_E} (\Phi_{j,i,b} + \beta_{j,i,b} \cdot P_{j,i,b}) P_{j,i,b} t_{j,i} + \sum_{m=1}^{N_{HP}} \sum_{i=1}^{N_T} (\Phi_{m,i,b} + \beta_{m,i,b} * P_{m,i,b}) P_{m,i,b} \cdot t_{m,i} \right) + \\ & a \cdot \sum_{i=1}^{N_T} \sum_{b=1}^{N_B} \left(P_{DNO}(i, b) - \sum_{Rtl=1}^{n_F} P_{Rtl}^{Init}(i, b) \right)^2 + d \cdot P_{Loss} + \\ & \sum_{i=1}^{N_T} \sum_{b=1}^{N_B} \lambda(i, b) \cdot \left(\sum_{Rtl=1}^{n_F} P_{Rtl}(i, b) - P_{DNO}(i, b) \right) \end{aligned} \quad (A14)$$

where the optimization variables of optimization problem (A14) are $\lambda(i, b)$, $P_{Rtl}(i, b)$, and $P_{DNO}(i, b)$. Note that—as indicated in (1)— $P_{Rtl}(i, b)$ is a combination of $P_{j,i,b}$ and $P_{m,i,b}$. Thus, the real optimization variable of the optimization problem above is $P_{j,i,b}$ and $P_{m,i,b}$.

References

1. International Energy Agency. *Global EV Outlook 2016 Beyond One Million Electric Cars*; International Energy Agency: Paris, France, 2016.
2. European Heat Pump Association. *European Heat Pump Market and Statistics Report 2015 Executive Summary*; European Heat Pump Association: Bruxelles, Belgium, 2015.
3. Smart Grid Strategy. *The Intelligent Energy System of the Future*; Danish Ministry of Climate, Energy and Building: Copenhagen, Denmark, 2013.
4. Energinet.dk; Danish Energy Association. *Smart Grid in Denmark 2.0*; Energinet.dk: Fredericia, Denmark; Danish Energy Association: Frederiksberg, Denmark, 2014.

5. Ai, Q.; Fan, S.; Piao, L. Optimal scheduling strategy for virtual power plants based on credibility theory. *Prot. Control Mod. Power Syst.* **2016**, *1*, doi:10.1186/s41601-016-0017-x.
6. Sundstrom, O.; Binding, C. Flexible Charging Optimization for Electric Vehicles Considering Distribution Grid Constraints. *IEEE Trans. Smart Grid* **2012**, *3*, 26–37.
7. Huang, S.; Wu, Q.; Oren, S.S.; Li, R.; Liu, Z. Distribution Locational Marginal Pricing Through Quadratic Programming for Congestion Management in Distribution Networks. *IEEE Trans. Power Syst.* **2015**, *30*, 2170–2178.
8. Subbarao, K.; Fuller, J.C.; Kalsi, K.; Somani, A.; Pratt, R.G.; Widergren, S.E.; Chassin, D.P. *Transactive Control and Coordination of Distributed Assets for Ancillary Services*; Pacific Northwest National Laboratory: Richland, WA, USA, 2013.
9. Hu, J.; Yang, G.; Kok, K.; Xue, Y.; Bindner, H.W. Transactive control: A framework for operating power systems characterized by high penetration of distributed energy resources. *J. Mod. Power Syst. Clean Energy* **2016**, *5*, 451–464.
10. Melton, R.B. *Gridwise Transactive Energy Framework Version 1*; Tech. Rep. PNNL-22946; The GridWise Architecture Council: Richland, WA, USA, 2015.
11. Weckx, S.; D’hulst, R.; Claessens, B.; Driesensam, J. Multiagent charging of electric vehicles respecting distribution transformer loading and voltage limits. *IEEE Trans. Smart Grid* **2014**, *5*, 2857–2867.
12. Hu, J.; Yang, G.; Bindner, H.W.; Xue, Y. Application of Network-Constrained Transactive Control to Electric Vehicle Charging for Secure Grid Operation. *IEEE Trans. Sustain. Energy* **2017**, *8*, 505–515.
13. Kok, K.; Warmer, C.; Kamphuis, I. Powermatcher: Multiagent control in the electricity infrastructure. In Proceedings of the 4th International Joint Conference on Autonomous Agents and Multiagent Systems, Utrecht, The Netherlands, 25–29 July 2005; Association for Computing Machinery (ACM): New York, NY, USA, 2005; pp. 75–82.
14. Yu, R.; Yang, W.; Rahardja, S. A Statistical Demand-Price Model with Its Application in Optimal Real-Time Price. *IEEE Trans. Smart Grid* **2012**, *3*, 1734–1742.
15. Lofberg, J. YALMIP: A toolbox for modeling and optimization in MATLAB. In Proceedings of the 2004 IEEE International Symposium on Computer Aided Control Systems Design, New Orleans, LA, USA, 2–4 September 2004; pp. 284–289.
16. Zimmerman, R.D.; Murillo-Sánchez, C.E.; Thomas, R.J. MATPOWER: Steady-State Operations, Planning and Analysis Tools for Power Systems Research and Education. *IEEE Trans. Power Syst.* **2011**, *26*, 12–19.
17. Boyd, S.; Xiao, L.; Mutapcic, A. *Subgradient Methods*; Stanford University: Stanford, CA, USA, 2003.
18. Danish Energy Regulatory Authority. *2015 National Report to the European Commission Denmark*; Danish Energy Regulatory Authority: Valby, Denmark, 2015.
19. Kitzing, L.; Katz, J.; Schröder, S.T.; Morthorst, P.E.; Andersen, M. *The Residential Electricity Sector in Denmark: A Description of Current Conditions*; Technical University of Denmark: Lyngby, Denmark, 2016.
20. Dromacque, C. *European Residential Energy Price Report 2013*; Vaasa ETT Global Energy Think Tank: Helsinki, Finland, 2013.
21. Dalsgaard, M.; Yang, G.; Hu, J. *Application of Transactive Control for Integrating Distributed Energy Resources into an Enhanced Distribution System*; Technical University of Denmark: Lyngby, Denmark, 2016.
22. Marra, F.; Yang, G.; Træholt, C.; Østergaard, J.; Larsen, E. A decentralized storage strategy for residential feeders with photovoltaics. *IEEE Trans. Smart Grid* **2014**, *5*, 974–981.

