

12-2014

Development of a Heart Rate Variability Measurement System using Embedded Electronics

Naresh Kumar Velmurugan
University of Arkansas, Fayetteville

Follow this and additional works at: <http://scholarworks.uark.edu/etd>

 Part of the [Bioelectrical and Neuroengineering Commons](#), [Biomedical Devices and Instrumentation Commons](#), and the [Cardiology Commons](#)

Recommended Citation

Velmurugan, Naresh Kumar, "Development of a Heart Rate Variability Measurement System using Embedded Electronics" (2014). *Theses and Dissertations*. 2035.
<http://scholarworks.uark.edu/etd/2035>

This Thesis is brought to you for free and open access by ScholarWorks@UARK. It has been accepted for inclusion in Theses and Dissertations by an authorized administrator of ScholarWorks@UARK. For more information, please contact scholar@uark.edu, ccmiddle@uark.edu.

Development of a Heart Rate Variability Measurement System using Embedded Electronics

Development of a Heart Rate Variability Measurement System using Embedded Electronics

A thesis submitted in partial fulfillment
of the requirements for the degree of
Master of Science in Electrical Engineering

By

Naresh Kumar Velmurugan
Saveetha University
Master of Engineering in Robotics, 2013
Pallavan College of Engineering
Bachelor of Engineering in Electronics and Communication, 2012

December 2014
University of Arkansas

This thesis is approved for recommendation to the Graduate Council.

Dr. Vijay K. Varadan

Dr. Simon Ang

Dr. Roy McCann

Abstract:

Recent advances in embedded electronics have a remarkable influence on the health care system. One of the most important applications is to monitor the health care of the patients at anytime and anyplace. In the last two decades, many researchers have focused mainly on heart rate variability (HRV) measurements. Patient's heart rate variability should be continuously monitored to help them in case of emergency. Under these circumstances, patients are required to have a HRV measuring kit for a constant observation.

The proposed project focuses on the development of a heart rate variability measurement system with the use of embedded electronics. This project consists of two systems: transmitter and a receiver side system. The transmitter section composed of sensor, amplifier, processing unit, and display unit, and transmitter module. The sensors, which are pasted on the body, are used to sense the electrical activity of the heart. These electric signals are given to an amplification unit. This amplification unit is designed with IC ADS1293 to amplify and filter the signals, and also reduce the noise. The output of the amplifier is given to the processing unit. Here, the microcontroller is programmed to process the input signal, and calculate the heart rate. The output of the microcontroller is transmitted to the display unit. The display unit shows the current value of the heart rate. The continuous measurement of heart rate variability is done in the transmitter side system. In case of abnormalities, a GSM module is used to transmit the heart rate alert, which has been processed by the control unit, to the user's mobile phone and GSM receiver modem. In the receiver system, GSM receiver modem receives the data and processed with Visual Basic program to display, and, in the mobile phone, data is received and displayed as a text message.

This kind of health monitoring system can offer flexibilities and cost saving options to both health care professionals and patients.

Acknowledgement

It is with utmost sincerity that I extend my deep and heartfelt thanks to my thesis advisor Dr. Vijay K. Varadan: who has the attitude and substance of a genius: he continually and convincingly conveyed a spirit of adventure in regard to research and scholarship, and an excitement in regard to teaching. His expertise in wireless health care system improved my research skills and prepared me for the future challenges. I could not have imagined having a better advisor and mentor for my master study.

Besides my advisor, I would like to thank the rest of my thesis committee: Dr. Simon Ang and Dr. Roy McCann for their encouragement, insightful comments, and hard questions.

To my friends: without your encouragement, help, and support, I do not know how I would have made it through this course of work. More specifically, many thanks to Mouli Ramasamy: you kept me focused, cleared away the doubts that cropped up for me, and were such a tremendous guide throughout this thesis. I am lucky to have a friend like you.

Finally, to my family: my parents have been influenced in getting me to this point in my life, and it is through their support, their constant care of all of my wishes, aims, and ambitions have led me to where I am today. I can say with absolute certainty that without you, without the support of my sisters, my brothers-in-law, my nieces and nephews, I would not be here. I dedicate this thesis to all of you.

Table of Contents

Chapter 1 INTRODUCTION

1.1 The heart anatomy	1
1.2 Background	2
1.3 Cardiovascular Diseases	3
1.3.1 Statistics and Data	4
1.4 Point of care patient monitoring	5
1.5 Proposed system	7

Chapter 2

HEART RATE VARIABILITY

2.1 Heart rate variability	9
2.1.1 Electrocardiogram	9
2.1.2 Conduction system of heart	10
2.1.3 Leads	11
2.1.4 ECG waves and interval	13
2.1.5 Noise in ECG Signal	15
2.2 HRV analysis	15
2.2.1 Time-domain methods	15
2.2.2 Geometric methods	16
2.2.3 Frequency-domain methods	18
2.2.4 Non-linear methods	19
2.2.5 Long term correlations	20

2.3 Correlation and Differences between Time and Frequency Domain Measures	20
--	----

Chapter 3 State

of the Art

3.1 Alternative Approaches	22
3.1.1 iPhone ECG	22
3.1.2 smart Pad	22
3.1.3 Life Touch HRV011	23
3.1.4 TruVue	23

Chapter 4 WIRELESS

SYSTEM

4.1 GSM	26
4.2 GSM System Architecture	28
4.2.1 Mobile Station (SIM + ME)	30
4.2.2 Base station subsystem (BSS)	30
4.2.3 Network Subsystem (NSS)	31
4.2.4 Operating Subsystem (OSS)	33

Chapter 5

HRV MEASUREMENT AND MONITORING SYSTEM

5.1 System architecture	35
5.2 Hardware unit	37
5.2.1 Transmitter side system	37
5.2.1.1 Sensor	37

5.2.1.2 Amplifier	39
5.2.1.3 Microcontroller and power management	40
5.2.1.4 Display unit	42
5.2.1.5 GSM module	44
5.2.2 Receiver side system	46
5.2.2.1 Mobile phone system	46
5.2.2.2 Hospital server system	46
5.3 Software unit	47
5.3.1 Coding for transmitter section	47
5.3.2 Coding for receiver section	48

Chapter 6

EXPERIMENTAL RESULTS OF THE HRV SYSTEM

6.1 Test procedure	50
6.2 Experimental results	50
6.3 Conclusion	52

Chapter 7

CONCLUSION AND FUTURE WORK	53
REFERENCE	55
APPENDIX	60

List of Figures

Figure 1.1 The heart conduction system	1
Figure 1.2 Deaths from cardiovascular diseases in 2010 (USA)	5
Figure 1.3 Concept of Heart rate variability measurement and transmission alert	8
Figure 2.1 Conduction system of heart	11
Figure 2.2 Precordial chest electrodes are normally placed on the left side of the chest	13
Figure 2.3 Schematic representation of normal ECG waveform	14
Figure 2.4 HRV Analysis Process	16
Figure 4.1 GSM system architecture	29
Figure 5.1 System architecture	36
Figure 5.2 Transmitter side systems	37
Figure 5.3 Sensor	38
Figure 5.4 Amplifier unit	40
Figure 5.5 PIC 16F877A – Microcontroller	41
Figure 5.6 Power management	42
Figure 5.7 Interfacing LCD with PIC	44
Figure 5.8 Interfacing GSM with PIC	44
Figure 5.9 Overview of software coding	49
Figure 6.1 Subject with HRV measuring kit	51
Figure 6.2 ECG signal of the subject	51

List of Tables

Table 2.1 Types of leads used in ECG monitoring	12
Table 2.2 Amplitude and duration of waves, intervals and segments of ECG signal	15
Table 2.1 Approximate correspondence of Time domain and Frequency domain methods Applied to 34-Hour ECG Recordings	21
Table 5.1 Pins used to interface with PIC UART1_Write_Text (AT_CMFG)	43
Table 6.1 Tested heart rate result	52

Chapter 1

INTRODUCTION

1.1 The heart anatomy

The heart contains four chambers that are atrium dextrum, atrium sinistrum, ventricle, heart ventricle. However, there are other auriculoventricular and Sino chambers present as well. This can clearly be illustrated in the figure 1 below. The two upper parts are the left and right atria. While the two lower chambers are the left and right ventricles. Ventricles are connected to the atrium by fibrous so that the non-conductive tissue can keep the ventricles electrically away from the atria [1]. Blood is flown into the lungs through the right atrium and the hart ventricle. Giant veins receive the oxygen free blood. These veins are known as the superior and inferior veins that flow into the atrium. The right chamber contracts and strengths blood into the proper ventricle, extending the ventricle and expanding its pumping (compression) strength. The atrium cordis and the heart ventricle pump in order to help in the flow of the blood containing oxygen that is received from the lungs in the same way as the right chamber does [2].

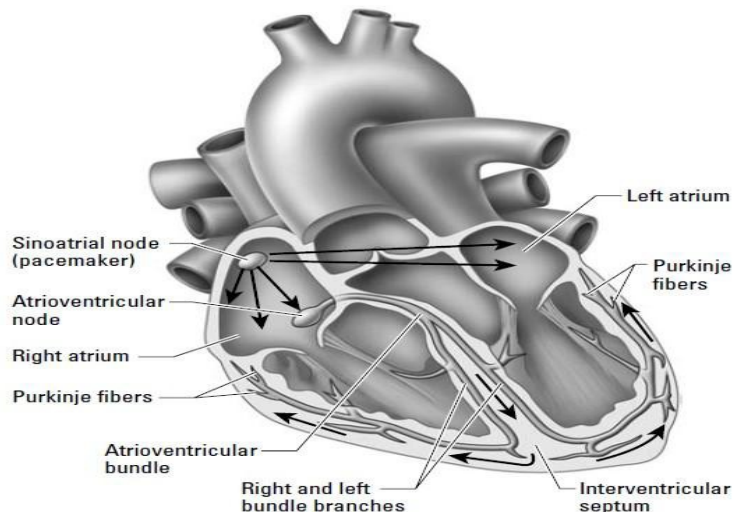

Figure 1.1 The heart conduction system [1].

The heart comprises of the Sino-atrial (S-A) node that creates the usual electrical impulse. This when spread to the conduction system starts the contraction of the myocardium. Depolarization is attained through the propagation of the electrical impulse which passes through the excitable tissue [2]. A strong ionic current is created as a result of it. This current flow passes the resistive body and creates drop in the voltage. Electrodes that are attached to the skin can easily sense the voltage drop as its magnitude is large enough. Therefore, ECGs can be taken as the recordings of the drop in the voltage that is spread throughout the skin as a result of the myocardial depolarization. The P-wave is the electrical impulse that is the result of the atrial depolarization. On the other hand, ventricular depolarization spreads the electrical impulse in whole of the ventricular myocardium [3].

1.2 Background

In order to diagnose the diseases of heart, the use of technology and history of the last decade of the 19th century was combined by physicians and researchers. The capillary electrometer was found by Gabriel Lippmann back in 1872 in order to the strength of electric signals in the human body. After almost twenty years, the chest x-ray was brought to peoples attentions in 1895. The electrocardiograph was then provided in 1902. It was used to illustrate the structure and the functions that the heart performs. A string galvanometer was utilized in the first electrocardiograph in order to make a note of the potential capitulation of the extremities coming about because of the electrical initiation of the heart. The letters P, Q, R, S and T were used by Einthoven in order to illustrate the electrocardiograph (EKG) waveforms for which he was awarded the Nobel Prize [5].

The first electrocardiograph machine in the USA was invented in 1909 by Alfred Cohn. The first manufacture of the EKG machine designed in the USA was by Professor Horatio

Williams and in 1914 Charles Hindle built the machine based on that design. In the early 20th century many new inventors brought changes into the EKG device, remodeling it several times. This resulted in the founding of the 12-lead electrocardiogram [4] [5] [6].

The basic principles of the era of the twentieth century are still used even though there have been many developments made in the electrocardiography. The only changes that have been seen are in the size and the accuracy of the calculating device [6].

1.3 Cardiovascular Diseases

Cardiovascular diseases are also called heart disease, which involved in blood vessels (arteries, capillaries, and veins), heart or sometimes both. In case the cardiovascular system is affected because of a disease, it is termed as a cardiovascular disease. The main causes of the cardiovascular diseases are hypertensions and atherosclerosis. These causes do not just effect the heart but are also quite threatening to the kidney, the brain and the peripheral arteries [8].

When a substance known as plaque is formed over the walls of the arteries it is known as Atherosclerosis which makes it hard for the veins to let blood flow through as the arteries are narrowed down or contracted. This can eventually result in blood clotting which stops the blood flow and the person suffering from it has to undergo heart attacks or strokes. A heart stroke is suffered from when the blood flow is blocked while it is flowing to the heart and takes the shape of a clot [9].

The blood flow has to go through the heart and it is because this very fact that the heart cells damage when a person is hit with a stroke. In simpler words, when the blood does not get to the brain because of the clot that is formed, the cells die. There is no replacement method or possibility of these cells however; some cells are inactive which

does not as a result in their damage and a few certain types grow back themselves. The cells in the brain that are healthier than the damaged cells take their place and cover up for the loss that the affected areas have to suffer. Strength, speech and memory are improved because of this recovery. It is known as rehabilitation [10].

1.3.1 Statistics and Data:

The Coronary corridor infection (CHD) is the most genuine atherosclerotic ailments, as uncovered by the heart stroke that a person may suffer. In 2010, 41 percent of the United States populaces had died because of cardiovascular, lung, and blood maladies. Chronic lower respiratory diseases (CLRD), which incorporates chronic obstructive pulmonary disease (COPD), are the other diseases which have been ranked by the CVD [10].

From 1999 to 2010, the death rates for CHD and stroke were decreased in non-Hispanic whites and non-Hispanic blacks; CHD and heart stroke demise rates declined among Hispanics, Asians, and American Indians however kept stable or increased in the years 2009 and 2010. CHD and stroke mortality has stayed the greatest in the black population. Because of fast decrement in mortality from CHD, there were 1,223,000 less deaths from CHD in 2010 than there could have been if there was no drop seen from the effect of the CHD [10].

Huge enhancements have been made in the treatment of CVD. Since 1990, the percentage of hospitalizations for AMI, heart stroke and heart failure that were released as dead diminished over time. From 1990 to 2010, CHD mortality turned down in the United States, yet stayed higher than the number of different nations that were researched upon, particularly among females. From 2001 to 2010, the rate drop in death rates for CHD and stroke was genuinely regular for whites and blacks. Below is a chart that illustrates the above

mentioned points.

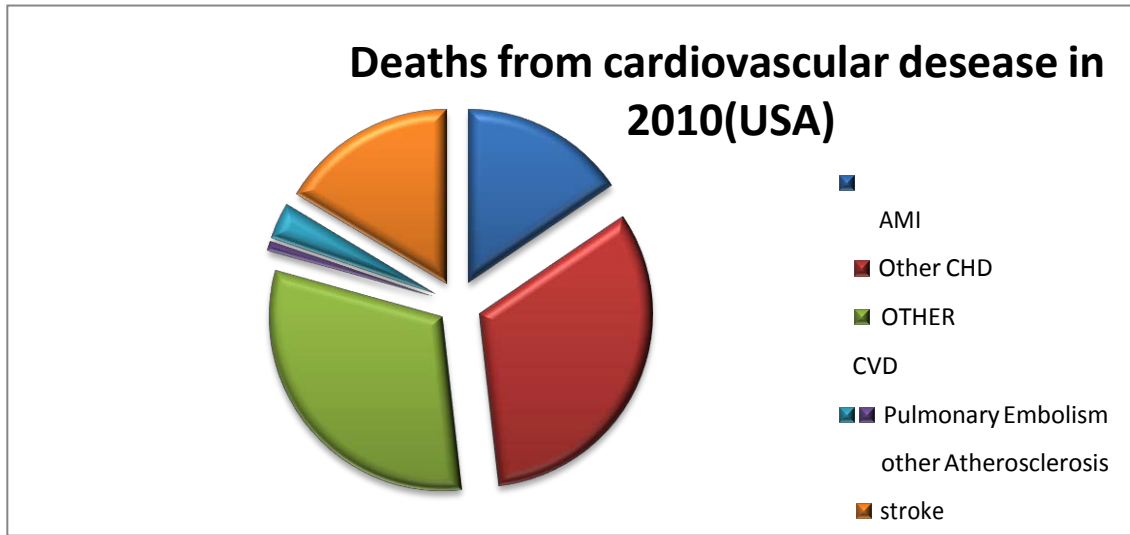

Fig.1.2 Deaths from cardiovascular diseases in 2010 (USA)

1.4 Point of care patient monitoring

Restorative observing units have proven as beneficial from the innovative advances in remote correspondence sign transforming and the sources of power. These advances have made conceivable scaling down and delayed operation of medicinal gadgets, and in addition their worldwide mix into tele- restorative framework. This permits patients to have ordinary day by day exercises. Framework architects are confronting particular issues identified with screen adequacy, application prerequisites, power utilization and framework network.

As of now, there are two various types of ECG frameworks that are utilized. The essential one is the standard ECG that typically includes twelve or fifteen leads that are associated with the patients' midsection, arms and right legs through cathodes. The gadget records the ECG signal for virtually thirty seconds. Potential diseases are frequently found from perusing the ECG signal. Then again, in view of brief time for testing, irregular abnormalities happen inside the Intensive Care Unit (ICU). With a specific end goal to

handle the matter specified, persistent cardiogram measure is utilized by a few healing facilities to watch the patient with in the unit. This gadget has three cathodes that secure ECG signal for an augmented sum. The sign is then prepared and showed on a screen as the heart rate of the sufferer. The Wireless HRV perception System arranged here falls in the second class of HRV gadgets, as it will be utilized to screen the heart action of subjects. Numerous HRV machines, both standard and consistent, are promoted as "versatile", however they aren't basically minor and lightweight. Moreover, most apparatuses get power from an electrical outlet and are sufficiently substantial that they have to be mounted on a cart and wheeled from one area to the other. Remote gadgets can impressively enhance this case by decreasing the load and size of such gadgets and by taking out the fundamentals for force or lead links.

Remote patient recognition frameworks fit for gathering critical patient information like the facts that the heart rate will deter the need for repetitive visits to the healing facility. In addition, such frameworks that perpetually screen the human physiology will offer significant information to visualize the onset of vital wellbeing issues. The way to such remote wellbeing restorative claim that the styles of negligibly meddle low esteem sensors that don't obstruct a calm standard life. However, at a comparable time they gather solid commotion which is free of information inside the current framework offered. It utilizes the GSM base for the most part remote sensing component framework with a disposable locator component and replaceable component which is stuck as an Agcl anode. The cathode allows non-educational recognition of the palatial stream of blood in the veins and the terminal uses sign transforming module to process the sign with a low clamor. The insight gathered from the patient are regularly remotely seen and investigated by the doctors. This

model stipulates that upholding the clinical detail will result in a revision in beat wave which is spread with age, vein solidness and alternative associated pathologies.

1.5 Proposed system

Previously, ECG signal is measured and transmitted to the server using Bluetooth, Zigbee or mode of transmission. In that system, all the data are processed and the waveform of the ECG signal is shown. Due to this system, the output cannot be viewed in single module.

There is more power required for transmitting the signal continuously.

Now current system replaces the unwanted transmissions and processes the data within the same system (module). Here the figure shows the concept of proposed system. In this system, Ag/AgCl electrodes are used to sense electrical signals of the heart beats and given to the amplifier. This amplifier consists of ADS1293 which is used to amplify the input signal and filter the noise. The filtered signal is fed to the microcontroller as an input. The microcontroller calculates the heart rate variability, based on the given input from amplifier. The calculated heart rate is given to the display which shows the heart rate of the output. The display will also provide the information of heart whether it beats in normal condition or not. In case of abnormality, the heart rate alert will be send.

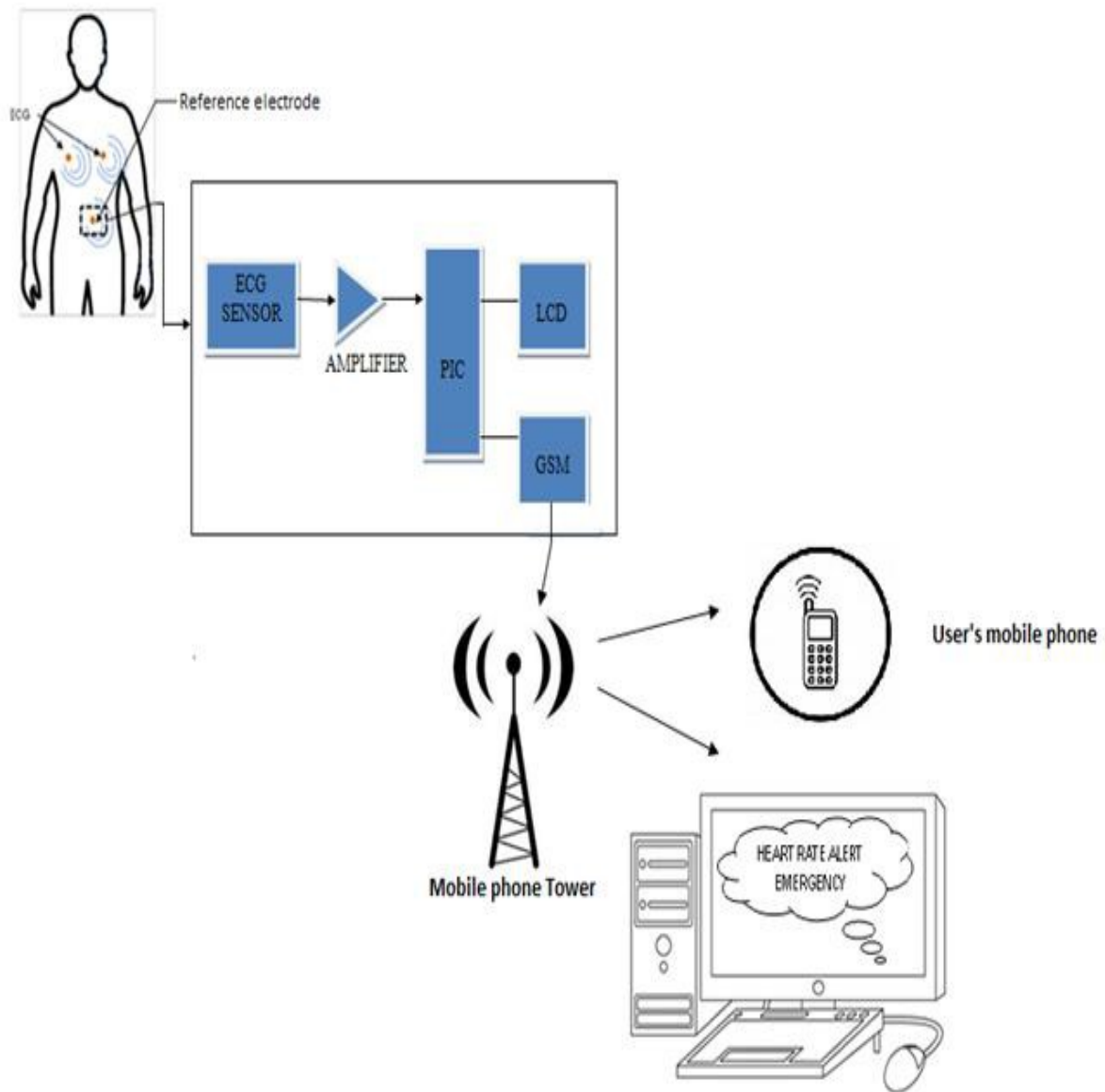

Figure 1.3 Concept of Heart rate variability measurement and transmission alert

Chapter 2

HEART RATE VARIABILITY

2.1 Heart rate variability

The physiological phenomenon of heart pulsated variety as per time is called as heart rate variability. It is figured by the variety in the beat-to-beat interval. HRV can likewise be called as "cycle length variability", "heart period variability" and "RR variability" (where R is the point from the QRS mind bogging of the ECG wave; and RR characterizes the progressive interim between Rs) [11]. In HRV phenomena, the primary two changes are respiratory arrhythmia or respiratory sinus arrhythmia, and low- recurrence swaying.

Respiratory arrhythmia relies upon the breath and distinguishes the respiratory rate at a scope of frequencies. Low- recurrence swaying acts with pulse and at a recurrence scope of 0.1hz or a 10 sec period. One of the strategies to distinguish heart pulsates is Electrocardiogram (ECG) [12].

2.1.1 Electrocardiogram?

ECG (ECG/EKG) is a theatrical performance of the electrical action of the heart muscle as recorded from the body surface, which is used in the analysis of heart disease. William Einthoven developed it in 1903 using a crude galvanometer. This electrical activity is connected to the impulse that travels through the heart, which determines its rate and regular recurrence. For a full ECG examination of a patient, he/she must be cabled up with 12 electrodes. The ECG signal obtained represents the polarization and the depolarization of the cells during a heartbeat Electrocardiogram (ECG) is a diagnosis tool that reported the electrical activity of heart recorded by skin electrode. The morphology and heart rate reflects

the cardiac health of human heart- beat [13]. It is a noninvasive technique that means this signal is measured on the surface of human body, which is used in identification of the heart diseases [14]. Any disorder of heart rate or rhythm, or change in the morphological pattern, is an indication of cardiac arrhythmia, which could be detected by analysis of the recorded ECG waveform. The amplitude and duration of the P-QRS-T wave contains useful information about the nature of disease afflicting the heart. The electrical wave is due to depolarization and re polarization of Na^+ and k^+ ions in the blood [14]. The ECG signal provides the following information of a human heart [15]:

- Heart position and its relative chamber size
- Impulse origin and propagation
- Heart rhythm and conduction disturbances
- Extent and location of myocardial ischemia
- Changes in electrolyte concentrations
- Drug effects on the heart.

ECG does not afford data on cardiac contraction or pumping function [16].

2.1.2 Heart Conduction system:

The cardiovascular conduction framework is a gathering of particular heart muscle cells in the dividers of the heart that send signs to the heart muscle making it contract. The principle parts of the heart conduction framework are the SA hub, AV hub, heap of His, pack extensions, and Purkinje strands. The SA hub (anatomical pacemaker) begins the succession by bringing about the atrial muscles to contract. From that point, the sign makes a trip to the AV hub, through the heap of His, down the group limbs, and through the Purkinje filaments, creating the ventricles to contract. This sign makes an electrical current that can be

seen on a diagram called an Electrocardiogram (EKG or ECG). Specialists utilize an EKG to screen the heart transmission through the electrical signals in the heart [20] [21].

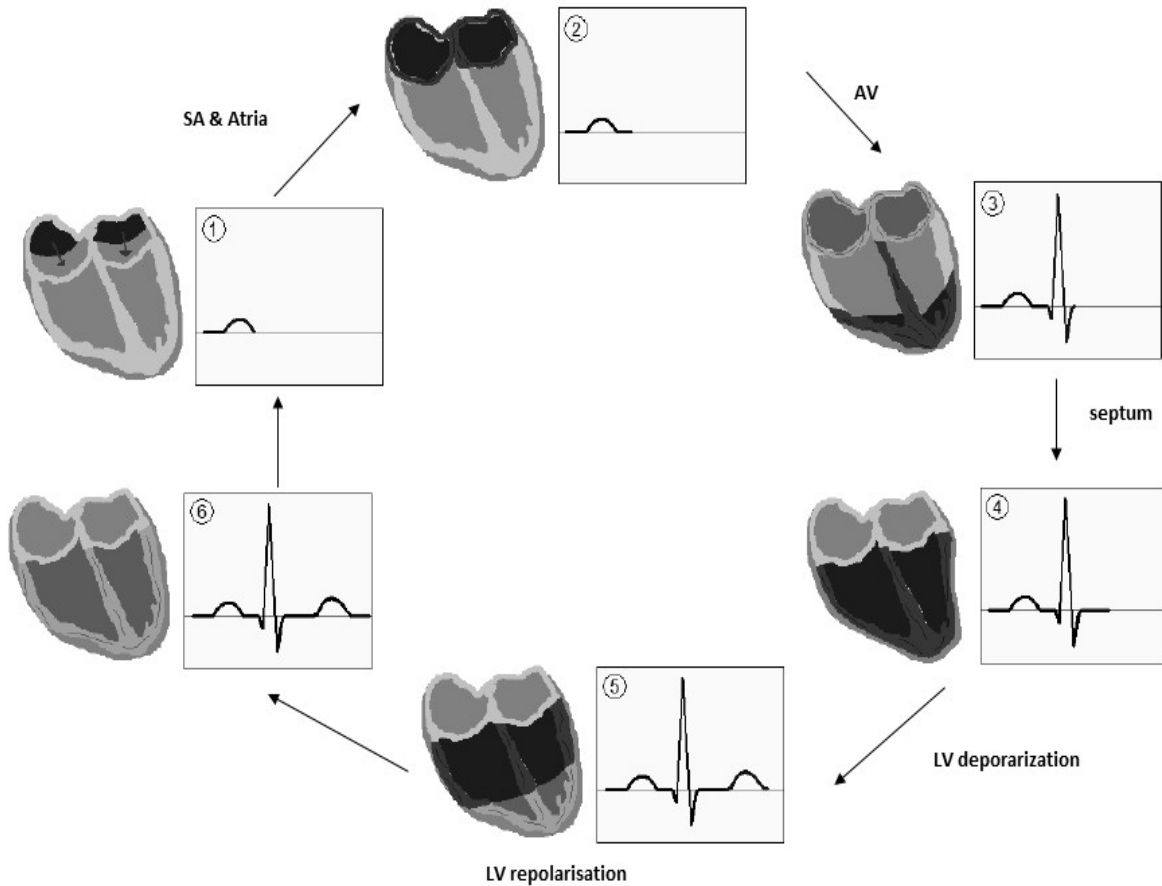

Figure 2.1 Conduction system of heart [22]

2.1.3 Leads

The standard ECG has 10 electrodes of “12-lead”, which are used for measuring ECG signal. This includes bipolar leads, augmented unipolar leads and precordial leads [20]. A lead can be referred as the tracing of electrical potential at a specific point and it has a particular name for each. A positive and negative electrode can form a lead to measure ECG signal. For

instance, Lead 1 is used to trace the voltage between the electrodes pasted on right arm and left arm, whereas Lead 2 is used to identify the voltage between the electrodes placed on right limb and the feet. In the way, 12 of this type of lead form a “12-Lead” ECG. The Bipolar leads are used to record the potential difference between two points (+ve & -ve poles). Unipolar leads are used to record the electrical potential at a particular point by means of a single exploring electrode. [23]

Leads I, II and III are commonly referred to bipolar leads as they use only two electrodes to derive a view. One electrode acts as the positive electrode while the other as the negative electrode (hence bipolar) [1] [3] [11] [17]

Standard	Limb	Chest
Leads	Leads	Leads
Bipolar leads	Unipolar leads	Unipolar leads
		V1
Lead I	AVR	V2
Lead II	AVL	V3
Lead III	AVF	V4
		V5

Table 2.1 Types of leads used in ECG monitoring [18]

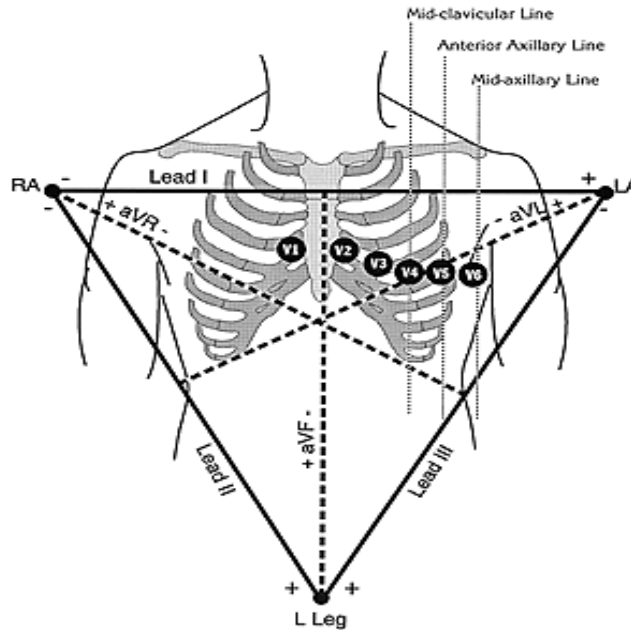

Figure 2.2 Precordial chest electrodes are normally placed on the left side of the chest [11]

2.1.4 ECG waves and interval

Waves

Representation

P wave

the amplitude level of this voltage signal wave is low (approximately 1 MV) and represent depolarization and contraction of the right and left atria. A clear P wave before the QRS complex represents sinus rhythm. Absence of P waves may suggest atrial fibrillation, functional rhythm or Ventricular rhythm [19].

It is very difficult to analyze P waves with a high signal-to-noise ratio in ECG signal.

QRS complex

The QRS complex is the largest voltage deflection of approximately 10–20 mV but may vary in size depending on age, and gender. The voltage amplitude of QRS complex may also give information about the cardiac disease [24].

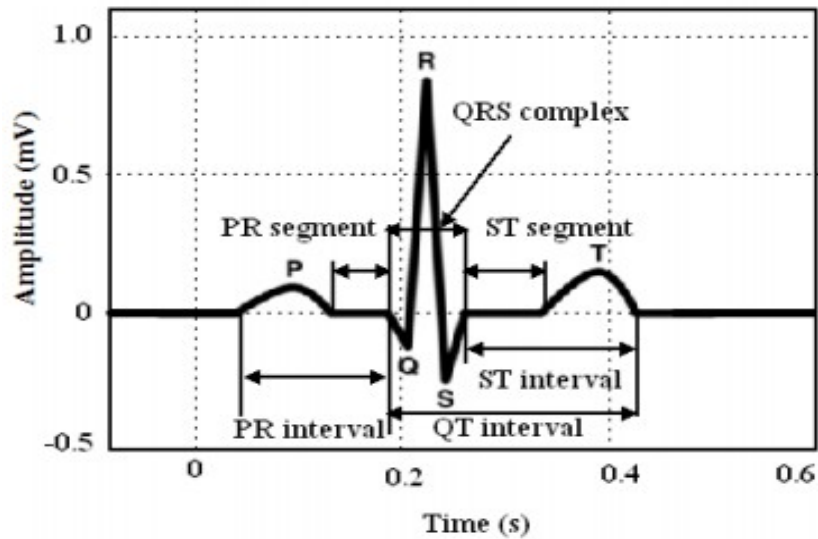

Figure 2.3 Schematic representation of normal ECG waveform [25]

The table 2.2 shows features of P-wave, QRS complex and T wave in maximum amplitude and its duration. According to medical definition [7], the duration of each RR-interval is about 0.4-1.2s.

Sl. no.	Features	Amplitude (mV)	Duration (ms)
1	P wave	0.1-0.2	60-80
2	PR-segment	-	50-120
3	PR- interval	-	120-200

5	ST-segment	-	100-120
6	T –wave	0.1-0.3	120-160
7	ST-interval	-	320
8	RR-interval	-	(0.4-1.2) s

Table 2.2 Amplitude and duration of waves, intervals and segments of ECG signal [26].

2.1.5

Noise in ECG Signal

For the most part the recorded ECG sign is regularly defiled by distinctive sorts of commotions and antiquities that can be inside the recurrence band of ECG sign, which may change the qualities of ECG sign. Thus it is hard to concentrate on valuable data of the sign.

2.2 HRV analysis

To examine the HRV, there are four separate techniques that can be utilized in particular, Time- area strategies, geometric routines, recurrence space systems, non direct strategies and long correlation method [28], demonstrated in the figure 2.4. Time-area and recurrence routines are the most generally utilized techniques used to measure the heart rate variability [29].

2.2.1 Time-domain methods

The varieties in heart rate may be assessed by various strategies. Possibly, the least difficult to perform are the time area measurements. In these systems, either the heart rate or the interims between progressive ordinary buildings are resolved. In a nonstop ECG record,

every QRS complex is recognized, and then purported normal to-**typical** (NN) interims or the prompt heart rate is a dead set [30]. Basic time space variables that can be ascertained incorporate the basic NN interim, the mean heart rate, the contrast between the longest and briefest NN interim, the distinction in the middle of night and day heart rate, et cetera. Other time area estimations that can be utilized are varieties as a part of quick heart rate auxiliary to breath, tilt, Valsalva move, or phenylephrine implantation. These distinctions can be portrayed as either contrasts in heart rate or cycle length [27].

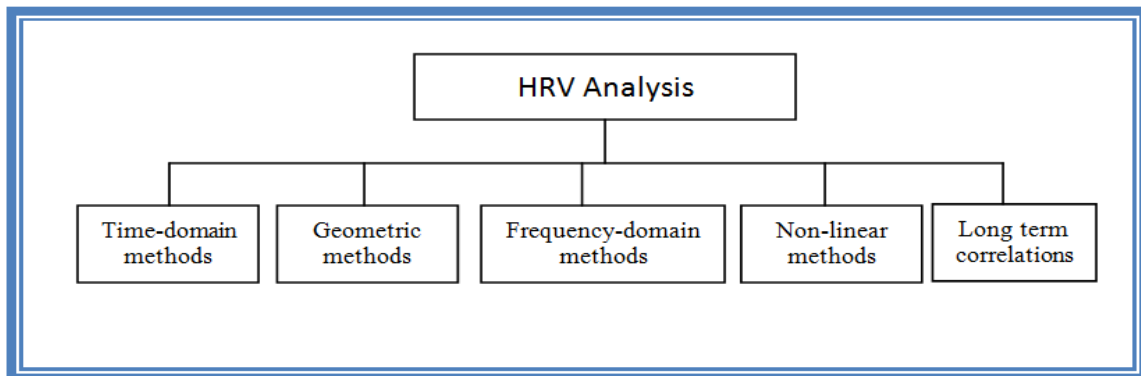

Figure 2.4 HRV Analysis Processes [29]

2.2.2 Geometric methods

The arrangement of NN interims likewise can be changed over into a geometric example, for example, the specimen thickness, the circulation of NN interim, test thickness dissemination of contrasts between adjoining NN interims, Lorenz plot of NN or RR interims and a basic recipe is utilized that judges the variability on the premise of the geometric properties of the ensuing example. Three general methodologies are utilized within geometric routines:

- (1) An essential estimation of the geometric example (for instance, the width of the appropriation histogram at the detailed level) is changed over into the measure of HRV.
- (2) The geometric example is interjected by a numerically characterized shape (for instance, estimate of the circulation histogram by a triangle or rough guess of the differential histogram by an exponential bend) and afterwards, the parameters of this scientific shape is utilized.
- (3) The geometric shape is arranged into a few example based classifications that speak to the diverse classes of HRV (for instance, elliptic, straight, and triangular states of Lorenz plots) [31].

The HRV triangular record estimation is the basic of the thickness appropriation isolated by the most extreme of the thickness circulation. Utilizing an estimation of NN interims on a discrete scale, the measure is approximated by the quality, which is subject to the length of the container, that is, on the exactness of the discrete scale of estimation. Accordingly, if the discrete estimation of the measure is utilized with the NN interim estimation on a scale not the same as the most regular examining of 128 Hz, the extent of the canisters ought to be cited. The triangular interjection of NN interim histogram (TINN) is the pattern width of the dissemination measured as a base of a triangle approximating the NN interim dispersion. Both these measures express general HRV measured in excess of 24 hours and are more impacted by the lower than by the higher frequencies. Other geometric strategies are still in the period of investigation and clarification [32].

The significant focal point of the geometric techniques lies in their relative heartlessness to the explanatory nature of the arrangement of NN interims. The significant impediment of the geometric techniques is the requirement for a sensible number of NN interims to build the geometric example. In practice, recordings of no less than 20 minutes ought to be utilized to guarantee the right execution of the geometric techniques; that is, the current geometric strategies are improper to evaluate fleeting changes in HRV.

2.2.3 Frequency-domain methods

Recurrence area is a standout amongst the most ordinarily utilized systems that focus the heart rate. In this system, a band of recurrence to the RR interim and later check the quantity of RR interim that goes under each one band.

- High recurrence (HF) – 0.15hz to 0.4hz
- Low recurrence (LF) – 0.004 to 0.15hz
- Very low recurrence (VLF) – 0.0033 to 0.4hz

Different unreasonable techniques for the dissection of the tachogram have been connected since the late 1960s. Power unearthy thickness (PSD) examination gives the essential data of how power disseminates as a capacity of recurrence. Free of the strategy utilized, just an evaluation of the genuine PSD of the sign can be acquired by fitting scientific calculations [32].

Techniques for the count of PSD may be by and large named nonparametric and parametric. In many cases, both routines give practically identical results. The favorable circumstances of the nonparametric systems are:

- (1) The effortlessness of the calculation utilized within the greater part of the cases
- (2) The high preparing velocity.

While the points of interest of parametric strategies are:

- (1) Smoother otherworldly parts that can be recognized autonomous of preselected recurrence groups
- (2) Simple post transforming of the range with a programmed computation of low- and high- recurrence power segments with a simple ID of the focal recurrence of every segment
- (3) A precise estimation of PSD even on a little number of specimens on which the sign should keep up stationary.

The fundamental impediment of parametric strategies is the need to check of the suitability of the picked model and of its multifaceted nature [32].

2.2.4 Non-linear methods

Given the multifaceted nature of the components directing heart rate, it is sensible to expect that applying HRV investigation focuses around techniques for non-direct elements that will yield beneficial data. Albeit tumultuous conduct has been expected, more thorough testing has demonstrated that heart rate variability can't be depicted as a disorderly process. The most ordinarily utilized non-direct technique for breaking down heart rate variability is the Poincare. Every information point speaks to a couple of progressive beats; the x-pivot is the current RR interim, while the y-hub is the past RR interim. HRV is

measured by fitting scientifically characterized geometric shapes to the information.

Different systems utilized are the relationship measurement, nonlinear consistency, point shrewd connection measurement and surmised entropy [34] [35].

2.2.5 Long term correlations

Arrangements of RR interims have been found to have long haul relationships. That may be because, one blemish with these breaks down the absence of integrity of-fit detail, i.e. qualities are determined that might possibly have sufficient measurable meticulousness [36].

2.3 Correlation and Differences between Time and Frequency Domain Measures

In the dissection of stationary transient recordings, more experience and hypothetical learning exist on physiological elucidation of the recurrence space measures contrasted and the time area measures got from the same recordings.

Despite what might be expected, numerous time and recurrence space variables measured over the whole 24-hour period are firmly related with one another (Table 3). These solid relationships exist due to both scientific and physiological connections. What's more, the physiological understanding of the phantom parts ascertained in excess of 24 hours are troublesome, in particular due to reasons specified above. Hence, unless extraordinary examinations are performed that utilize the 24-hour HRV sign to concentrate data other than the ordinary recurrence segments, the aftereffects of the recurrence space dissection are proportional to those of the time area examination, which is less demanding to perform [37].

Time Domain Variable	Approximate Frequency Domain Correlate
SDNN	Total power
HRV triangular index	Total power
TINN	Total power
SDANN	ULF
SDNN index	Mean of 5-minute total power
RMSSD	HF
SDSD	HF
NN50 count	HF
pNN50	HF
Differential index	HF
Logarithmic index	HF

Table 2.1 Approximate correspondence of Time domain and Frequency domain methods Applied to 34-Hour ECG Recordings [37].

Chapter 3

State of the Art

3.1 Alternative Approaches:

3.1.1 iPhone ECG

A strategy that as of now uses a PDA as an ECG is presently being developed by Alivecor. It meets expectations by appending two elongated metal knobs, which go about as cathodes, to yet again, an iPhone. The iPhone screen goes about as the ECG screen and can transmit the cardiovascular information of a understanding to the base station. For a healing facility, this would be a brisk option to the bigger ECG frameworks that need to be trucked into a patient's room. It requires less arrangement and is very convenient. The drawback to this framework, in examination to our configuration, is that it doesn't continually screen cardiovascular information unless an iPhone is strapped to their midsection. This gadget as a result, does not serve as a suitable long haul gadget [38].

Eric Topol, MD, who is one of the specialists testing this gadget, utilized it once on a plane to figure out whether somebody was enduring a heart assault. By applying this gadget the flight was compelled to make a crisis landing, and the individual's life was spared. A real upside to this gadget is that it can rapidly focus on the seriousness of a cardiovascular condition, for example, whether an individual is just experiencing acid reflux or in the event that they are under a heart failure.

3.1.2 SmartPad

A group of MIT understudies created an ECG observing framework that goes on in the

clinic cots keeping in mind that the end goal is to screen an indispensable sign. The cathode is set on the quaint, the patient lies upon it, mitigating the meddling of customary Ecgs. This framework functions admirably for long haul utilize and is not difficult to setup, yet does not permit the patient to be versatile. The essential utilization of this framework is amid surgeries as the remote cushion disposes of the cumbersome wires of current frameworks. The Smartpad is like our proposed task, yet fails to offer the versatility it requires, as the patient must be stable in bunk with the cushion underneath them for it to work appropriately [38].

3.1.3 Life Touch HRV011

Lifetouch is an industrially accessible remote ECG that is intended to give constant checking of patient after they leave concentrated forethought. The framework is like a vast band-support making it physically convenient; however the ability to convey is constrained to territories with Wi-Fi scope by the remote interface. Our task will develop the essential standards of this gadget by utilizing a Smartphone for sign preparing and information transmission, which will permit more power for sign handling and better portability utilizing versatile information [38].

3.1.4 TruVue:

The Truvue remote mobile ECG checking framework joins a refined arrhythmia investigation calculation with programmed remote information transmission to give a thorough long haul ECG observing answer for patients with existing cardiovascular arrhythmia. A patient may be observed with this framework for up to 30 days. The patient wears a small sensor joined by three terminals appended to their midsection. The sensor consistently digitizes a two-channel electrocardiogram and transmits it by means of

Bluetooth innovation to a handheld unit that can be conveyed to the patient or set close-by. The handheld unit uses cell correspondence innovation to transmit each beat of the two-channel electrocardiogram to secure servers placed at the 24 x 7 observing focus staffed by affirmed heart experts. Capable machine calculations examine the approaching ECG searching for changes in morphology, rate, or musicality or to distinguish markers demonstrating that the patient pressed the Event catch in light of the fact that they felt a manifestation [39].

A few college and private findings are identified with this work. The Codeblue undertaking, administered by the designing and connected science division at Harvard University, is the closest of these to our range of exploration. They are creating engineering to encourage ongoing triage in a debacle easing circumstances. By furnishing patients with remote sensors, they have showed the model's capacity to structure specially appointed sensor systems, gathered the key detail of every patient, and after that utilization framework programming to distinguish those patients in most basic need of restorative consideration. Their framework incorporates remote beat oximeter sensors, remote two-lead ECG sensors, and triaxial accelerometer based movement sensors for the observing of the patient. They are utilizing both custom sheets and off-the-rack sensor stages utilizing the Tinyos working framework. The continuous triage application and framework client interface live on a Personal Digital Assistant (PDA) [40].

Microsoft scientists in the Adaptive Systems and Interaction (ASI) Group have created Health gear, an arrangement of the system of inserted sensors checking human physiological information. Their examination is centered on utilizing the framework to perceive examples of human conduct when confronted with outside components, for

example, workload, anxiety, movement circumstances, activity, eating methodology, rest, and so on. They have utilized the framework as a part of a study on slumber apnea. Specifically, they utilized a blending of movement sensors and oximeter sensors to catch sporadic sleep designs.

The most recent two decades have seen a noteworthy increment in light of a legitimate concern for heart rate variability (HRV), which has been one of the guaranteeing improvements in non- intrusive electro cardiology. With the coming of fitting sign preparing strategies, HRV has given an understanding into the relationship of the autonomic sensory system and into the instruments by which it impacts illness movement and cardiovascular mortality [40].

Chapter 4

WIRELESS SYSTEM

4.1 GSM

The GSM standard (Global System for Mobile Communications) for versatile telephony was presented in the mid-1980s and is the European activity for making another cell radio interface. The GSM framework utilizes a TDMA radio access framework utilized in 135 nations, working in 200 KHz channels with eight clients for every channel. It is the most broadly conveyed computerized system on the planet today, utilized by 10.5 million individuals as a part of more than 200 nations [41].

4.2 GSM Bandwidth Allocation

GSM can work in four unique recurrence groups:

- GSM 450: GSM 450 backs extensive cells in the 450 Mhz band. It was intended for nations with a low client density, for example, in Africa. It might likewise supplant the first 1981nmt 450 (Nordic Mobile Telephone) simple systems utilized within the 450 Mhz band. NMT is an original remote innovation [41].
- GSM 900: When talking about GSM, the first GSM framework was called GSM 900 in light of the fact that the first recurrence band was spoken to by 900 Mhz. To give extra limit and to empower higher supporter densities, two different frameworks were included a while later:

- GSM 1800: GSM 1800 (or DCS 1800) is an adjusted form of GSM 900 working in the 1800mhz recurrence range. Any GSM framework working in a higher recurrence band obliges an expansive number of base stations than for any unique GSM framework. The accessibility of a more extensive band of range and a lessening in cell size will empower GSM 1800 to handle a greater number of supporters than Gsm900. The littler cells, actually, give enhanced indoor scope and low power prerequisites [41].

- GSM 1900 (or PCS 1900): PCS 1900 (Personal Communications System) is a GSM 1800 variety intended for utilization on the North American Continent, which utilizes the 1900 Mhz band. Since 1993, stage 2 of the details has included both the GSM 900 and DCS 1800 (Digital Cellular System) in a relatable point records. The GSM 1900 framework has been added to the IS-136 D-AMPS (Digital Advanced Mobile Phone System) and IS-95 Code Division Multiple Access (CDMA) framework which both work at the 1900 MHz brand[41].

The ITU (International Telecommunication Union) has dispensed the GSM radio range with the accompanying groups:

- GSM 900: Uplink: 890–915 Mhz

Downlink: 935–960 Mhz

- GSM 1800: Uplink: 1710–1785 Mhz

Downlink: 1805–1880 Mhz

- GSM 1900: Uplink: 1850–1910 Mhz

Downlink: 1930–1990 Mhz

In the above, uplink assigns association from the versatile station to the base station and downlink signifies association from the base station to the portable station [42].

4.3 GSM System Architecture

A cell containing a Mobile Station (MS) is structured by the radio scope zone of a Base Transceiver Station (BTS). A few Bts together are controlled by one Base Station Controller (BSC). The BTS and BSC act as a structure to the Base Station Subsystem (BSS). The consolidated activity of the Mss in their separate cells is directed through the Mobile Switching Center (MSC). A few databases are needed for call control and system administration: The Home Location Register (HLR), the Visitor Location Register (VLR), the Authentication Center (Auc), and the Equipment Identity Register (EIR). The GSM framework structure engineering includes a set of key parts which are represented in Figure 4.1. The GSM framework system can be partitioned into three subgroups that are interconnected utilizing institutionalized interfaces: Mobile Station (MS), Base Station Subsystem (BSS), and Network Subsystem (NSS). These subgroups are further embodied the segments in the following sections.

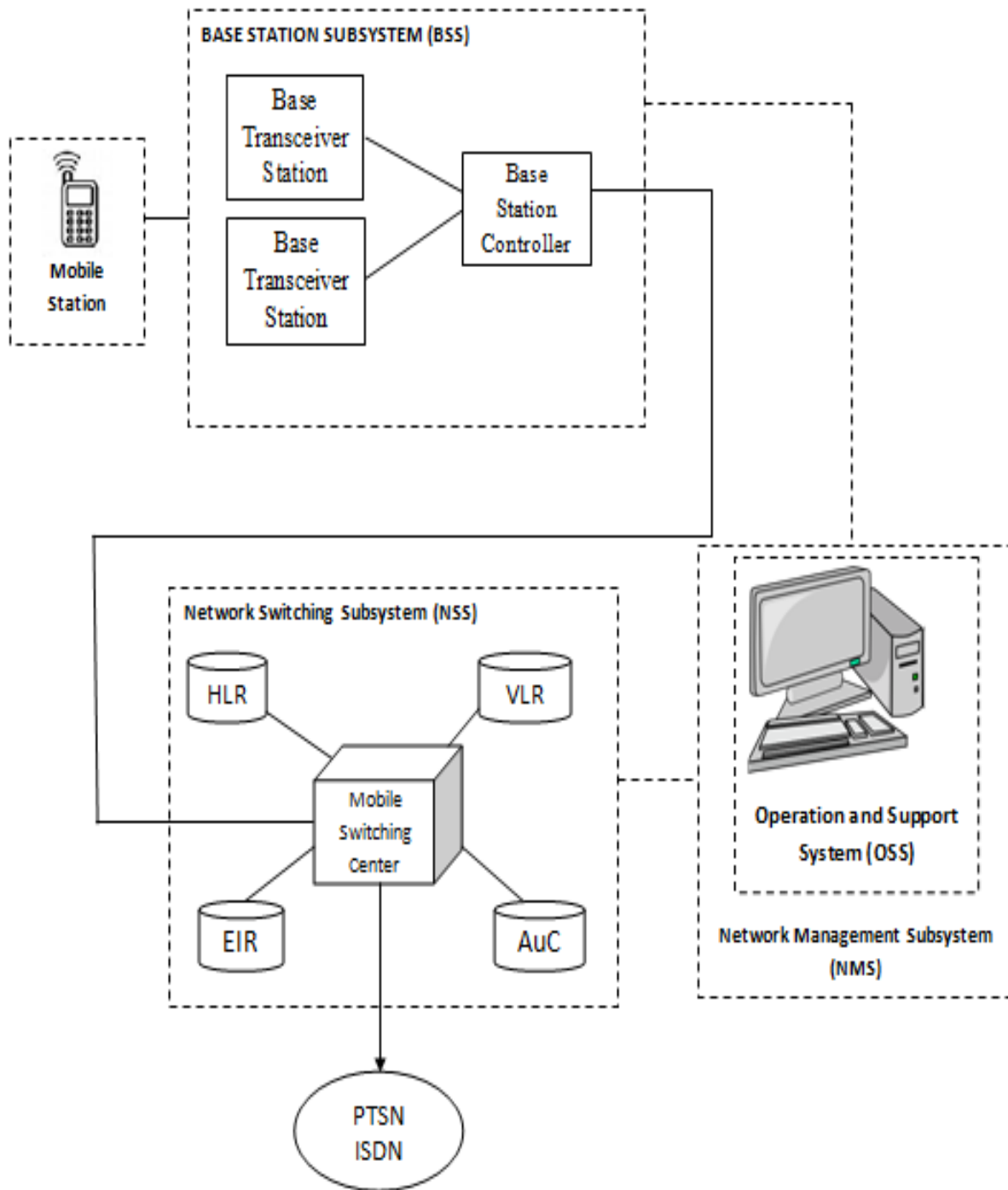

Figure 4.1 GSM system architecture [44]

4.3.1 Mobile Station (SIM + ME)

The Mobile Station (MS) can allude to a handset or a portable gear (ME). The Subscriber Identity Module (SIM) card in a GSM handset is a microcontroller keen card that safely stores different basic data. Every SIM card has a special ID number called the International Mobile Subscriber Identity (IMSI). Also, every MS is appointed to an extraordinary equipment ID called the International Mobile Equipment Identity (IMEI). A MS can likewise be a terminal (M-ES) that demonstrates as a GSM interface, that may be available, for a Portable computer [43].

4.3.2 Base Station Subsystem (BSS)

The Base Station Subsystem (BSS) comprises of the Base Transceiver Station (BTS) and the Base Station Controller (BSC). The BSS guarantees transmission and administration of the radio assets [44].

Base Transceiver Station (BTS):

The BTS is in charge of giving the remote association between the handset and the remote system. The GSM utilizes an arrangement of radio transceivers called Btss that give the purpose of entrance to the GSM system. A BTS is embodied with situated radio transmitters and recipients, and receiving wires to associate the portability to a phone system after the obliged call has been taken care of. The BTS takes in the calls inside its scope zone and guarantees their fitting is being taken care of.

Base Station Controller (BSC):

The essential capacity of the BSC is a call upkeep. As indicated in Figure 4.1, the BSC deals with the directing of correspondences from one or more base stations. A BSC controls a bunch of cell towers. It is in charge of setting up a voice or information call with the versatile terminal and overseeing handoff when the telephone moves starting with one phone tower limit then to the next, without any disturbance of administration. At the end of the day, the BSC oversees radio assets and guarantees the handover. The BSC likewise serves as the switch for focus towards the Gateway Mobile Switching Center (GMSC).

4.3.3 Network Subsystem (NSS)

The Network Subsystem (NSS) is made up of the two fundamental components, MSC and GMSC, alongside its supporting components: the Home Location Register (HLR), the Visitor Location Register (VLR), the Authentication Center (Auc), and the Equipment Identity Register (EIR). The NSS creates interchanges between a wireless and an alternate MSC, and deals with the Short Message Services (SMS) transmission. [41] [46]

• Mobile Switching Center (MSC):

The MSC controls call flagging and preparing, and direction of the handover of the portable association starting with one base station then onto the next as the flexibility meanders around. The MSC deals with the parts between cell exchange, versatile supporter guests, and interconnections with the PSTN. The joined movement of the versatile stations in their separate cells is directed through the MSC. A few databases mentioned above are accessible for call control and system administration. Those supporting components incorporate the area registers

comprising of HLR, VLR, EIR, and AUC. Every MSC is joined through GMSC to the nearby Public Switched Telephone Network (PSTN or ISDN) to give the integration between the portable and the settled phone clients. The MSC might likewise unite with the Packet Data Networks (PDN) to give mobiles access to the information administrations.

- Home Location Register (HLR):

The NSS is supported by HLRs. The HLR is a database utilized for administration of the administrator's versatile endorsers. Basically for all clients enrolled with a system administrator. Lasting information and interim information are put away in the HLR. On account of a call to a client, the HLR is constantly questioned first with respect to the client's present area. The fundamental data, put away in the HLR, concerns the area of every portable station keeping in mind the end goal to course call the versatile endorsers over looked by the HLR [41] [46].

- Visitor Location Register (VLR):

The VLR is in charge of a gathering of area territories, and stores the information of those clients who are at present in its zone of obligation. This may incorporate the changeless client information that has been transmitted from the HLR to VLR for speedier access. The VLR might likewise allot and store nearby information, for example, a transitory distinguishing proof. Concerning supporter versatility, the VLR becomes an integral factor by confirming the attributes of the endorser and guaranteeing the exchange of area data. The VLR contains the current area of the MS and chooses managerial data from the HLR. It is important for call control and procurement of the administrations for every versatile placed in the zones controlled by the VLR. AVL is associated with one MSC and regularly

incorporated into the MSC's equipment.

- Authentication Center (Auc):

The Auc holds a duplicate of the 128-bit mystery enter that is put away in each supporter's SIM card. These security-related keys are utilized for validation and encryption over the radio channel.

- Equipment Identification Register (EIR):

The GSM recognizes unequivocally between the client and the supplies, and manages them independently. The EIR registers supplies information instead of endorser information. It is a database that contains a rundown of all substantial versatile station gears inside the GSM system, where every portable station is recognized by its International Mobile Equipment Identity (IMEI). Hence, the IMEI interestingly recognizes a portable station globally. The IMEI is apportioned by the gear maker and enrolled by the system administrator who stores it in the EIR. The International Mobile Subscriber Identity (IMSI) recognizes each one enlisted client and is put away in the SIM. A mobile station can only be operated if a SIM with a valid IMSI is inserted into equipment with a valid IMEI [41] [46].

4.3.4 Operating Subsystem (OSS)

The Operating Subsystem (OSS) constitutes the system Operation and Maintenance Center (OMC) as the administrator's system administration apparatus.

- Network Operation and Maintenance Center (OMC):

The OMC is an administration framework, which administers the GSM utilitarian squares.

The OMC helps the system administrator in keeping up tasteful operation of the GSM system. The OMC is in charge of controlling and keeping up the MSC, BSC, and BTS.

Chapter 5

HRV MEASUREMENT AND MONITORING SYSTEM

The prototype implementation of the HRV monitoring system is best understood in the context of the motivating vision and proposed system architecture of a distributed ubiquitous health monitoring system. In the first subsection we describe this system architecture and the benefits it offers in light of the issues discussed in the introduction. The following subsections describe the hardware architecture of the prototype and the overview of the software architecture although primarily as a development environment.

5.1 System architecture

The figure 5.1 shows the architecture of HRV measuring and transmitting system module. The architecture can be classified into two: Transmitter side system and receiver side system. The transmitter side system consists of sensors, amplifier module, microcontroller unit, display unit, and Transmitter unit. Sensor detects the physiological signals. The amplifier module amplifies the signal received from the sensor. Then it filters the signal, before fetching into the microcontroller. Microcontroller unit processes the signal as converting the analog signal to digital signal (ADC conversion). After, converted signal has been processed to calculate the heart rate. The heart rate is rechecked by the microcontroller and microcontroller sends the data to the display unit. The heart rate variability is shown in the display unit. Moreover, microcontroller checks heart rate whether it is normal or not and displays in the display unit. It shows normal if heart rate is normal, otherwise it shows abnormal. If the heart rate is abnormal, an alert is sent to the

GSM module. This GSM module is used forward the alert message to the receiver unit. The receiver side system consists of mobile phone and GSM receiver module. The mobile phone and GSM receiver module receives the alert message at the same time. GSM receiver receives the alert message and fetches to the PC. In PC, the received message is processed through the visual program. Then it displays as a emergency for the patient.

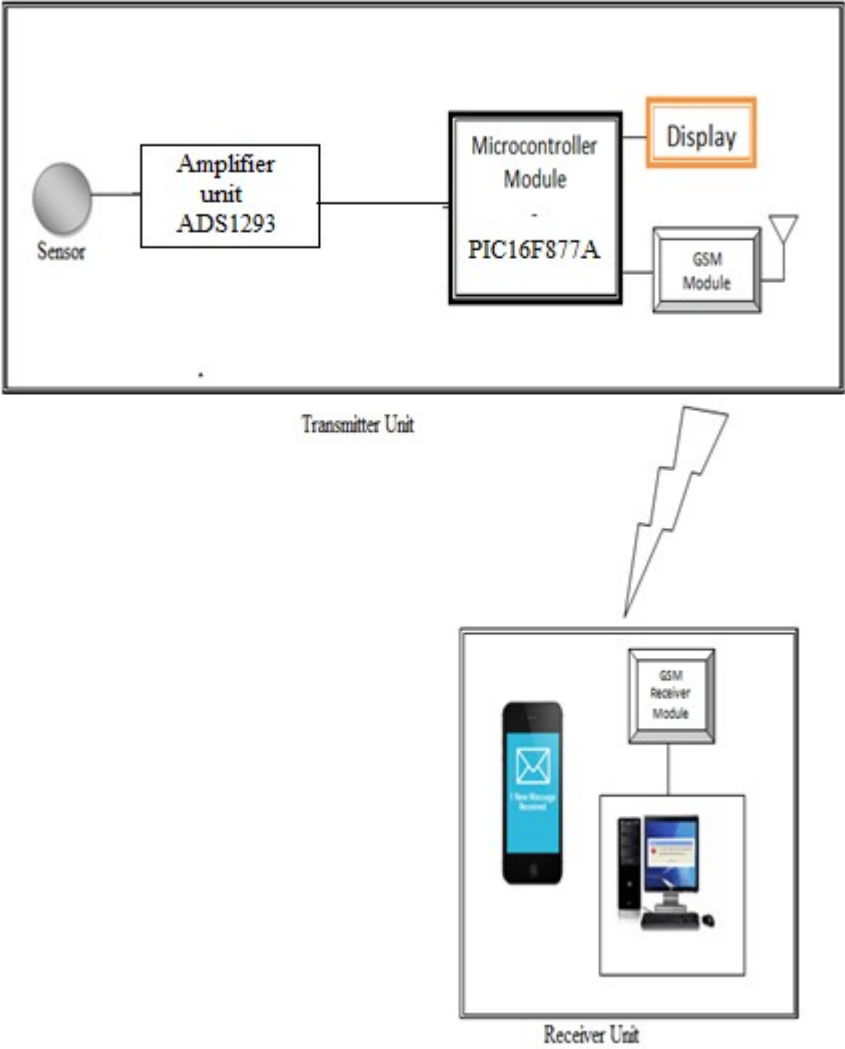

Figure 5.1 System architecture

5.2 Hardware unit

5.2.1 Transmitter side system

The transmitter side system is shown in the figure 5.2.

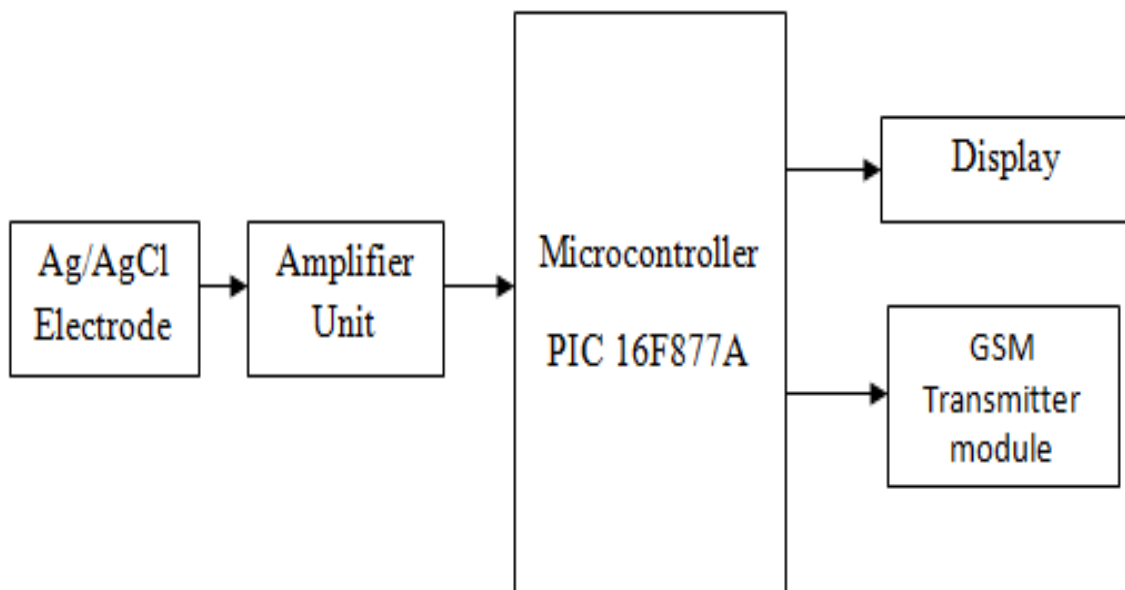

Figure 5.2 Transmitter side systems

5.2.1.1 Sensor

Sensor used to measure the electric potentials on the body. Here, in this system, conventional wet Ag/AgCl electrodes are used to sense the electric signal, where the conductive gel reduces the skin impedance or make conductive path through hairs [46]. The electrodes for the recording biopotentials are composed of a metal, usually silver and a salt of the metal. Coupled with this, a type of electrode jelly is placed in between the

electrodes and the skin. The silver metal of the electrode and the ionic electrode paste at the electrode-skin interface are seen to combine. Thus, some of the silver is seen to dissolve into the solution producing the Ag^+ ions:



At the point where the electric field that is set up by the dissolving ions is seen to be balanced with the forces acting on the concentration gradient, an ionic equilibrium is seen to develop. At this particular point, a monomolecular layer of the Ag^+ ions along with the corresponding layer of Cl^- ions at the surface of the electrodes. This specific potential is termed as the electrode double layer. This is followed by a drop in potential across the layer which is termed as the half cell potential. The figure 5.3 demonstrates the sensor that is placed so as to sense the signal from the body.



Figure 5.3 Sensor [46]

The pre gelled disposal electrode poses a circular contact and are considered to be the most suited for the purpose of achieving short term recording of biopotential signals. The small vinyl backing provides close placement of the electrode where important. The

mentioned disposable snap electrodes tend to provide similar signal transmission as the reusable electrodes with hygiene and convenience. The electrodes are pasted on the body and the outputs are given to the amplifier unit [46].

5.2.1.2 Amplifier

The raw physiological signals from the sensors are very weak, ranging from micro-volts to milli- volts, and contaminated by noises, especially 50/60Hz power line interference. Therefore, the signals need to be amplified and filtered to improve the signal to noise ratio. The body impedance and contact impedance between skin and the electrodes might vary under different skin conditions leading to impedance mismatches. Therefore, amplifier should have high common mode rejection ratio (CMRR) and high input impedance to maintain signal integrity [46]. The single integrated circuit, which can perform the entire analog front end for an ECG monitor, from Texas instruments, supports 3 leads ECG system and processes all the A/D conversion, and signal processing. We can connect the electrodes through the serial peripheral interface.

In ADS1293, there are three high resolution channels that have a capable of operation up to 25.6ksps. Each channel can be separately programmed for a particular sampling rate and bandwidth users to optimize for the power. The input will be routed to EMI filter and sent to flexible routing switch for selecting the channel. This has processed through the instrumentation amplifier and given to the digital filter. The digital filter is preprogrammed filter which is used to remove the noise and filter the incoming signal. Then the output is driven to the digital control and power management. We can get the digital output in DRDYB which is used as data ready bar. SDO can also provide the serial data output. The

right leg drive system and common mode detection are implemented, where CMOUT is used to provide the common mode detector output [55]. The final output in this integrated circuit would be a filtered and tuned digital signal.

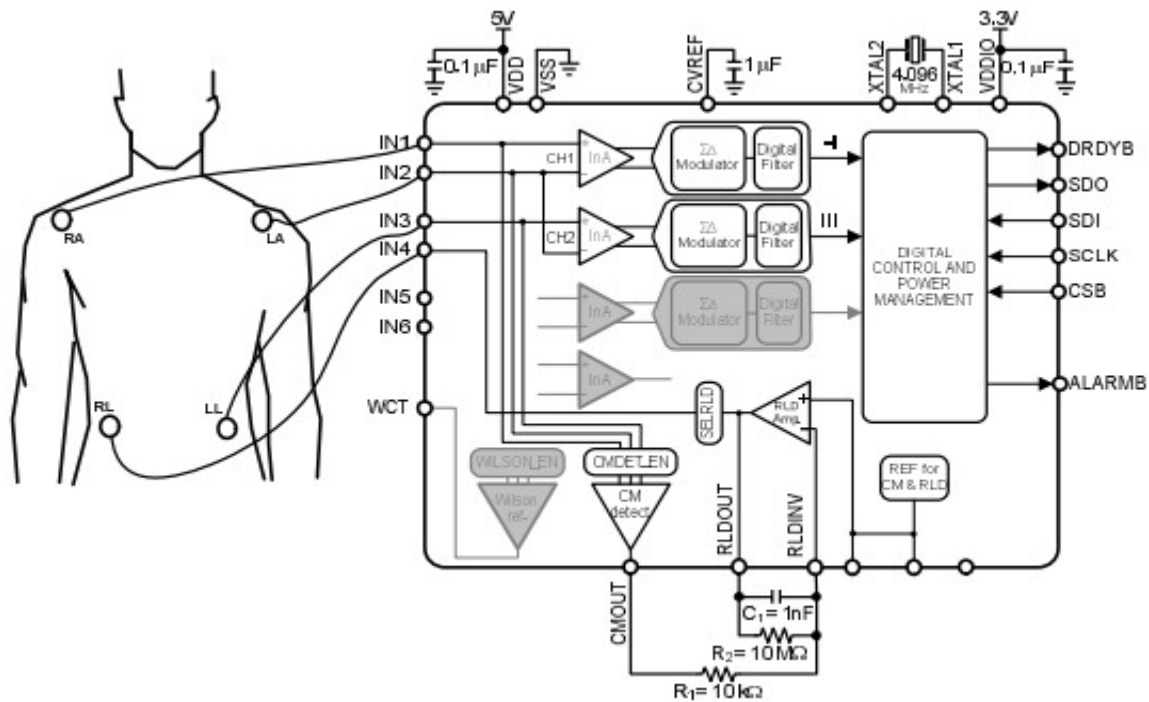

Figure 5.4 Amplifier Unit [55]

5.2.1.3 Microcontroller and power management

The main function of microcontroller in the system is data acquisition and converts the signal from analog to digital conversion. PIC 16F877A from microchip is used as a processor, which has 8-bit reduced instruction set computer (RISC) architecture, 8K x 14 words of flash memory, 368 x 8 bytes of data memory(RAM), 8-channel 10-bit A/D converter and other peripherals. The operating voltage ranges from 1.8 to 5.5v and the operating voltage of the processor is set at 5V with a 20MHz external resonator. The purpose of setting the operating voltage at 5V is to match the voltage level of the amplifier module.

The signal from the amplifier module is given port A (RA0). Then the signals are sampled and quantized in the microcontroller. The heart rate value is calculated and sent to the display unit [47] [48].

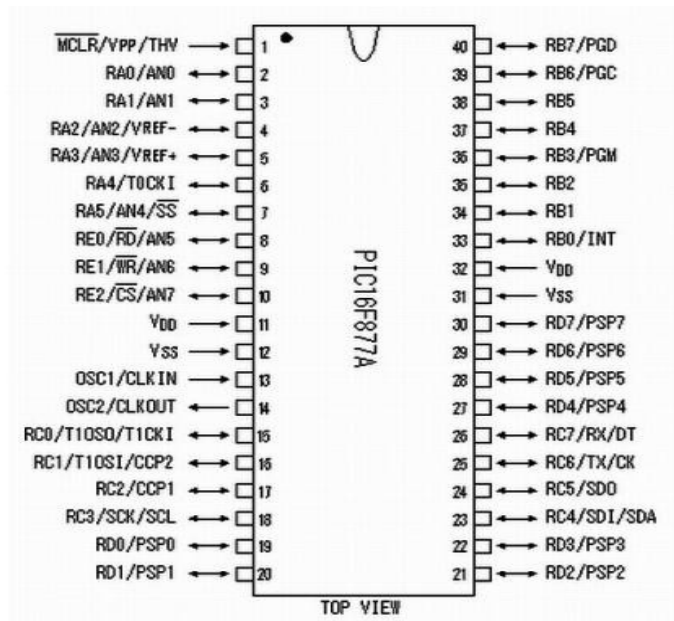

Figure 5.5 PIC 16F877A – Microcontroller

Power Management

An alkaline battery is used as a power source. Because each block of the system operates at different voltage level, a voltage regulators are used to step +5V for the GSM module, and the microcontroller and amplifier unit. Then IC 7805 voltage is used to bring out +5v for the microcontroller and the amplifier unit [49].

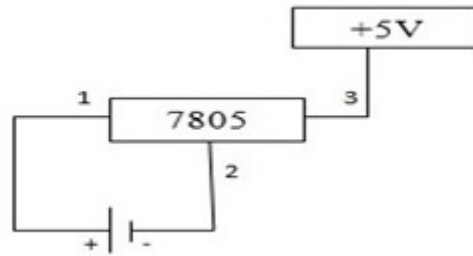

Figure 5.6 Power management

5.2.1.4 Display unit

The display unit consists of 16x2 LCD. The microcontroller calculates the heart rate and sends to the LCD. In the LCD, first row is reserved to display the heart rate and second row is reserved to display whether the heart rate is normal or abnormal. In the microcontroller, port B is used interface with the LCD. The table 5.1 shows the connecting pins between the LCD and the PIC.

LCD			PIC 16F877A
Pin no	Symbol	Function	Pin used to interface
1	VSS	GND	VSS
2	VDD	+5v	VDD
3	V0	Contrast adjustment	-
4	RS	H/L Register select signal	RE0

5	R/W	H/L Read/Write signal	RE1
6	E	H/L Enable signal	RE2
7	DB0	H/L Data bus line	RB0
8	DB1	H/L Data bus line	RB1
9	DB2	H/L Data bus line	RB2
10	DB3	H/L Data bus line	RB3
11	DB4	H/L Data bus line	RB4
12	DB5	H/L Data bus line	RB5
13	DB6	H/L Data bus line	RB6
14	DB7	H/L Data bus line	RB7
15	A	+4.2V for LED	VSS
16	K	Power supply for BKL (0V)	VDD

Table 5.1 Pins used to interface with PIC [51]

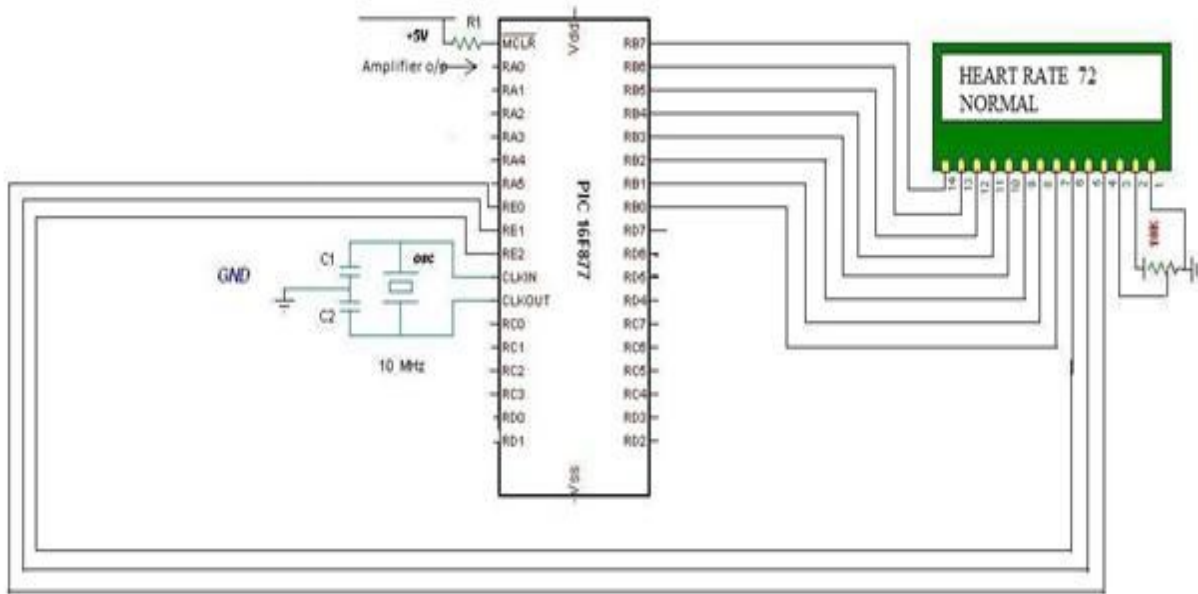

Figure 5.7 Interfacing LCD with PIC

5.2.1.5 GSM module

In this specific system, the GSM module is utilized for the purpose of transferring the alert message from the microcontroller. The mobile communication network is utilized in place of the local area networks for sending physiological signals to the receiver.

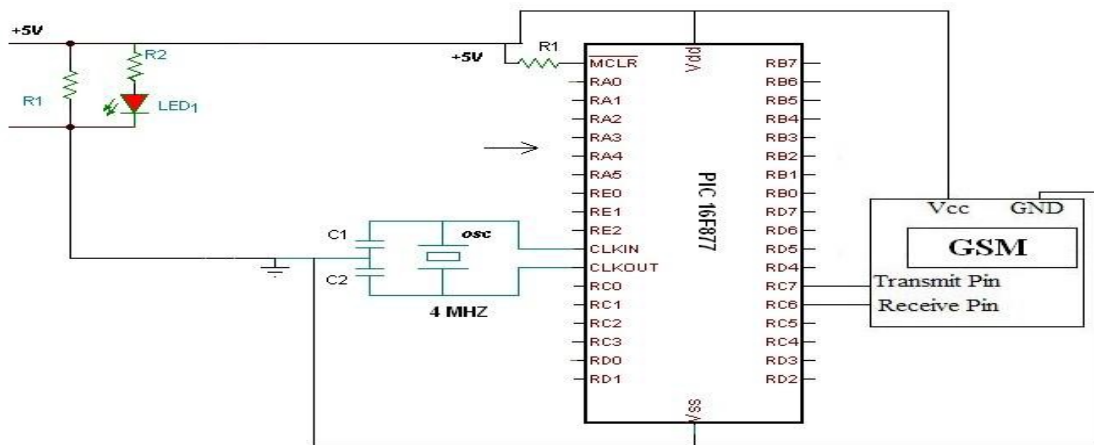

Figure 5.8 Interfacing GSM with PIC

The SIM900A model is used as the GSM transmitter module. SIM900A tends to support the quad-band GSM/GPRS/EDGE as well as the dual band UMTS/HSDPA. The opening voltage is fixed at 5V initially. The baseband and the RF power supplier to this specific module are supplied by the power from the IC7805. Furthermore, a SIM card is required for this GSM module. For the sole purpose of providing stability to the system and EMC, a large capacitor, with a capacity of 100uF, along with a by-pass capacitor is placed in close proximity to the voltage pins of the module. The turning on/off of the module is controlled by the power on/off logic within the module. The logic is seen to operate at a low value and is pulled up internally. In order to turn on the module automatically, when the switch is on, the logic is pulled down to the ground by means of the external resistor in the circuit [45].

As demonstrated in figure 5.10, the module is seen to communicate with the microcontroller over UART port. The microcontroller can be referred as the data terminal equipment while the module can be termed as the data communication equipment (DCE). This module not only provides a support for the null modem topologies but also the full modem. In this system, the null modem topology is utilized and the baud rate of UART interface is fixed at 115,200 bits per second. The universal subscriber identity module, USIM, is put into practice on the board for the purpose of association with the mobile network and authentication.

A transient-voltage-suppressor (TVS) diode array is utilized in between the USIM and the GSM/WCDMA module for the purpose of ESD protection. SIM900A is provided with numerous purpose of input/output (GPIO) and the GPIO status is read or written with the AT commands. Among all the GPIOs, one of them was used in order to indicate the status of

the network with a light emitting diode (LED). The status of the network, power off, network resignation and power on/ searching network is represented by the turn off/on intervals of the LED. The module is capable of supporting not only a quad band of GSM 850 MHz but also EGSM 900 MHz, DCS 1800 MHz and PCS 1900 MHz and dual-band of WCDMA 850 MHz and 1900 MHz,. For the covering up of the frequencies, Reflexus from Antenova and A penta-band SMD antenna is used. The average gain is -1.3 dBi for the 824-960 MHz and -1.5dBi for 1710-2710 MHz,. A specific micro strip line, which possess an impedance of 50Ohm is designed and utilized as a transmission line between the antenna and the module. To separate the DC blocking capacitor and the transmission line a matching circuit is placed between eh matching circuit and the module. For maximum antenna performance, it is place on the corner of the board.

5.2.2 Receiver side system

The main purpose of transmitting signal the heart rate is to the alert. Then they come to know that his/her heart rate is not in normal so that he/she needs emergency help to recover. The receiver side system consists of mobile phone and GSM receiver module.

5.2.2.1 Mobile phone system

The main advantage of this system is mobile phone can receive an alert with heart rate through the text message. It does not require any app to be installed or internet connection in the phone. This signal reception depends on the SIM card. So obviously, the signal can be received easily.

5.2.2.2 GSM receiver modem

GSM receiver module receives the signal from the GSM transmitter. This receiver is a one way communication, it cannot transmit the signal. The received signal in the GSM receiver is fed to the system using RS232 cable. The RS232 cable is used to interface the GSM

and processor. Then the processor receives the signal and processes using the Visual Basic software. This will display the patient name, heart rate and condition of the heart rate.

5.3 Software unit

The software module is carefully selected to perform all the operations. At first, a microcontroller program was implemented in the transmitter module, which includes peak detection, heart rate calculation, display in LCD and data transmission in GSM. In second, a receiver side was coded using Visual Basic to receive, and extract the data.

5.3.1 Coding for transmitter section

The signal from the amplifier circuit is given to RA0 pin in the microcontroller. ADS1293 software, which is provided by Texas Instruments, was used to represent the signal tuning. The general overview of the transmitter coding is shown in the figure 5.11. The input for the microcontroller is from the amplifier module which is given at the RA0 (Port A). RA0 pin is also called as AN0 (analog). This pin can be used as digital I/O and analog input. Then the controller is coded RA0 (Port A) as digital.

At first, peak amplitude is detected and the value of this peak voltage is compared the next peak amplitude. Then it takes the high amplitude as peak. After that this peak is set as a common line to detect the other peaks. Here, system has to identify the peak to peak value which means RR interval of the ECG signal, so the controller is programmed to find the RR interval. The heart rate is calculated by the period between peak to peak intervals. The heart rate will be varied according to the input from the amplifier module in RA0. Then the heart rate is fed to the LCD to display the current heart.

After calculating the heart rate, the system checks the heart rate value whether it is above 110 and below 50 or not. If it is above 110 or below 50, this value is considered as abnormal, so microcontroller sends the alert message through the GSM module.

5.3.2 Coding for receiver

In the receiver section, Visual Basic is used to provide the information which is received by the GSM receiver module. The coding was written to receive the heart rate alert and to process it to display.

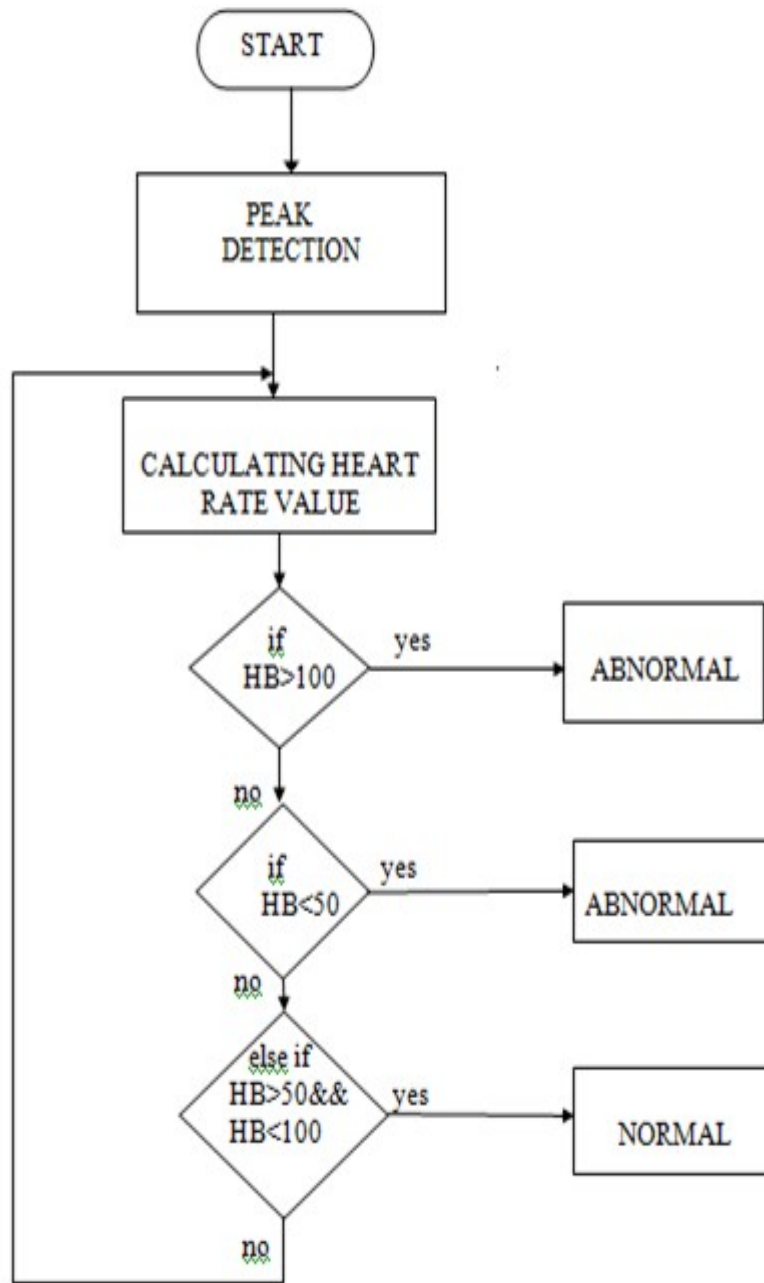

Figure 5.9 Overview of software coding

Chapter 6

EXPERIMENTAL RESULTS OF THE HRV SYSTEM

6.1 Test procedure

The experiments and test performed were used in initial system analysis threshold determination and system validation. In order to validate the feasibility of this system, two experiments were performed.

- 1) The bio potential signal was sensed and amplified using amplifier circuit. Then the peak detection was performed in order to get an accurate heart rate value.
- 2) The tuned signal was used to calculate the heart rate variability.

6.2 Experimental results

Two set of experiments were performed with the subjects. Firstly, electrodes were pasted on their body and the output of the electrode is connected to the amplifier circuit. Then ECG wave forms of the subjects were processed and displayed. Secondly, measuring the heart rate variability was performed and noticed.

Heart rate can be varied and it would be considered as abnormal, if it goes beyond 110bpm or below 50bpm [53] [54]. The figure 6.1 shows the subject tested with HRV machine. The figure

6.2 represents the ECG signal obtained using 3 lead system. The heart rate was calculated through the successive interval between RR points.

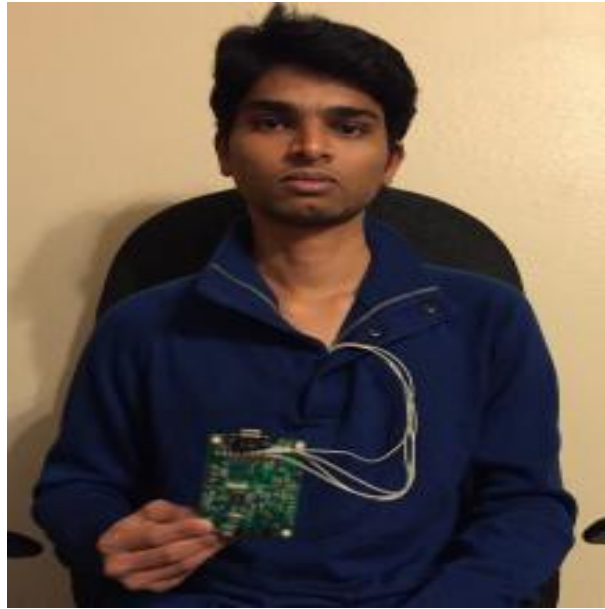
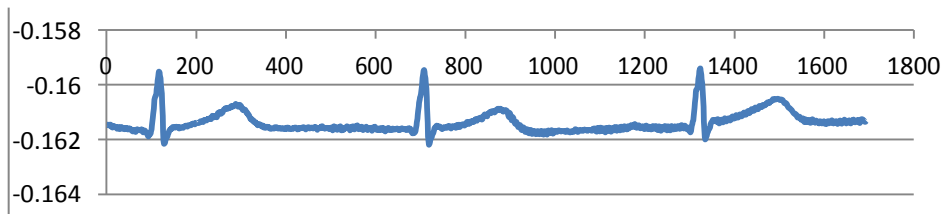
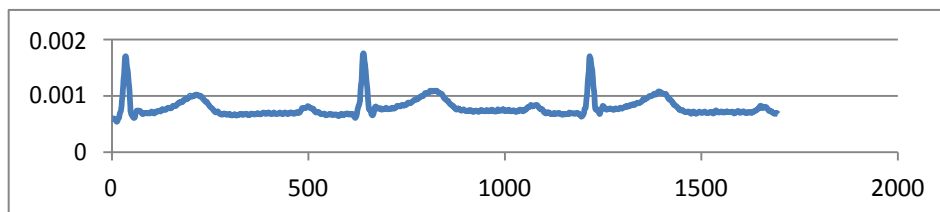

Figure 6.1 Subject with HRV measuring kit



a) Lead I



b) Lead II

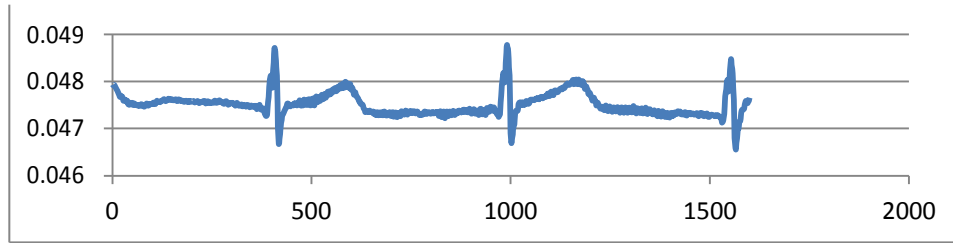

c) Lead III

Figure 6.2 ECG signal of 3 lead system

6.3 Conclusion

The heart rate variability measuring device was developed to monitor the heart rate continuously. To verify the system, the device was tested to define the heart rate variability. This system has electrode, amplifier, microcontroller, and LCD and wireless transmitter module. The Ag/AgCl electrode and GSM were chosen as the electrode and the wireless communication method.

Chapter 7

CONCLUSION AND FUTURE WORK

The research presented in this thesis describes about the real time heart variability monitoring and alerting system. A real time monitoring system was developed to evaluate the heart rate variability condition of the patient. This consists of three modules: an electrode, hardware module and software were designed, developed, and validated to implement the proposed real time measurement and alertness of the heart variability. During the research, various methods were studied and implemented:

First, sensors sense the bio potential signals and fed to the amplifier unit. In amplifier unit, the ECG signal was processed and filtered. In addition, signal gain strategies, principle and methods to design a circuit for amplification and to measure the signal were studied.

Second, a detailed study of background and about the commercially available devices were gathered and studied to deliver fundamental idea about the state of art in the recent technologies in research.

Third, a study of the microcontroller and available wireless communication standard was performed. Since the amplifier output will be a digital signal, PIC 16F877A was selected. Practically, the wired transmission protocol cannot be satisfied so long distance wireless communication protocol should be required to complete the system requirement. From the conducted study and tests, GSM/WCDMA communication satisfied all the conditions required for an effective system.

Fourth, this system needs an amplification unit to amplify the signal from electrode. For ECG waveforms, signal from electrode is amplified and removed the noise. The signals are also filtered to get low noise and improved the signal quality. For the ECG signal, the gain should be properly maintained in the amplifier circuit so that high CMRR is required to get accurate signal so ADS1293 is selected for the amplification unit. Then the output signal is fed to the microcontroller, in microcontroller, peak detection was performed and calculated the heart rate through RR interval. After that output is displayed in the LCD.

Finally, the prototype is tested with the subject. A subject has been tested to get the result and the result was analyzed. However, as any technical product, this system can be used as a prototype for future research to improve the performance and to adapt to the trend existing in that period. Some ideas which can be done in the future are as follows:

- 1) The processed data can be stored in the memory which can be used to monitor in the future.
- 2) The mobile app can be developed to display the ECG signal and the heart rate.
- 3) The developments in the technology should allow PP interval and PR interval variability to be investigate in future studies.

This chapter contains the conclusion of this research and the future work possible to improve the system.

REFERENCE

- [1] T.Ince, S. Kiranyaz, and M. Gabbouj, "A generaric and robust system for automated patient-specific classification of ECG signals," IEEE Trans. Biomed. Eng. vol. 56, pp. 1415-1426, 2009.
- [2] P.de Chazal, M.O. Duyer, and R.B. Reilly, "Automatic classification of heartbeat using ECG morphology and heart beat interval features," IEEE Trans. Biomed. Eng. vol. 51, pp. 1196-1206, 2004.
- [3] Y. Hu, S. Palreddy, and W. J. Tompkins, "A patient-adaptable ECG beat classifier using a mixture of experts approach," IEEE Trans. Biomed. Eng., vol. 44, no. 9, pp. 891–900, Sep. 1997.
- [4] Howell JD. Diagnostic technologies – X-rays, electrocardiograms, and cat-scans. South Calif Law Rev 1991; 65(1): 529–64. PubMed PMID: WOS:A1991HF35100023.
- [5] Fye WB. A history of the origin, evolution, and impact of electrocardiography. Am J Cardiol 1994; 73(13): 937–49. [Crossref]. PubMed PMID: WOS:A1994NL86800001.
- [6] Salerno SM, Alguire PC, Waxman HS. Training and competency evaluation for interpretation of 12-lead electrocardiograms: Recommendations from the American College of Physicians. Ann Intern Med 2003; 138(9): 747–50. PubMed PMID: WOS:000182661400008.
- [7] Bridget B. Kelly; Institute of Medicine; Fuster, Valentin (2010). Promoting Cardiovascular Health in the Developing World: A Critical Challenge to Achieve Global Health. Washington, D.C: National Academies Press. ISBN 0-309-14774-3.
- [8] Dantas AP, Jimenez-Altavo F, Vila E (August 2012). "Vascular aging: facts and factors". *Frontiers in Vascular Physiology* 3 (325): 1-2.doi:10.3389/fphys.2012.00325.PMC 3429093. PMID 22934073.
- [9] Countries, Committee on Preventing the Global Epidemic of Cardiovascular Disease: Meeting the Challenges in Developing; Fuster, Board on Global Health ; Valentin; Academies, Bridget B. Kelly, editors ; Institute of Medicine of the National (2010). Promoting cardiovascular health in the developing world : a critical challenge to achieve global health. Washington, D.C.: National Academies Press. pp. Chapter 2. ISBN 978-0-309-14774-3.
- [10] Braunwald E. (Editor), Heart Disease: A Textbook of Cardiovascular Medicine, Fifth Edition, p. 108, Philadelphia, W.B. Saunders Co., 1997. ISBN 0-7216-5666-8.

- [11] Brüser, Christoph; Stadlthanner, Kurt; de Waele, Stijn; Leonhardt, Steffen (2011). "Adaptive Beat-to-Beat Heart Rate Estimation in Ballistocardiograms". *IEEE Transactions on Information Technology in Biomedicine (IEEE)* 15 (5): 778-786. Doi: 10.1109/TITB.2011.2128337. PMID 21421447.
- [12] Brüser, Christoph; Winter, Stefan; Leonhardt, Steffen (2012). "Unsupervised Heart Rate Variability Estimation from Ballistocardiograms". 7th International Workshop on Biosignal Interpretation (BSI 2012), Como, Italy.
- [13] W. Jiang and S. G. Kong, "Block-based neural networks for personalized ECG signal classification," *IEEE Trans. Neural Netw.*, vol. 18, no. 6, pp. 1750–1761, Nov. 2007.
- [14] S. Osowski, T. H. Linh, and T. Markiewicz, "Support vector machinebased expert system for reliable heart beat recognition," *IEEE Trans. Biomed. Eng.*, vol. 51, no. 4, pp. 582–589, Apr. 2004.
- [15] Reisner, A. T., Clifford, G. D., & Mark, R. G. (2007). The physiological basis of the electrocardiogram.
- [16] Xue, Q., Hu, Y. H., & Tompkins, W. J. (1992). Neural-network-based adaptive matched filtering for QRS detection. *Biomedical Engineering, IEEE Transactions on*, 39(4), 317-329.
- [17] Lu, Y., Xian, Y., Chen, J., & Zheng, Z. (2008, May). A comparative study to extract the diaphragmatic electromyogram signal. In *BioMedical Engineering and Informatics, 2008. BMEI 2008. International Conference on (Vol. 2, pp. 315-319)*. IEEE.
- [18] Gupta, R., Chatterjee, H. K., & Mitra, M. (2012). An online ECG QRS Detection Technique. *Int. J. on Recent Trends in Engineering and Technology*, 7(2)
- [19] Mehta, S. S., & Lingayat, N. S. (2009). Identification of QRS complexes in 12-lead electrocardiogram. *Expert Systems with Applications*, 36(1), 820-828.
- [20] Das, S., & Chakraborty, M. (2012). QRS Detection Algorithm Using Savitzky-Golay Filter. *Aceee International Journal on signal & Image processing*, 3(1).
- [21] "What Makes Your Heart Beat" University of Maryland Medical Center. N.p., n.d. Web. 29 Oct. 2014.
- [22] A movie by the National Heart Lung and Blood Institute explaining the connection between an ECG and the electricity in heart: What Is the Heart?
- [23] "Electrophysiological Changes During Cardiac Ischemia". *Cvphysiology.com*. 26 March 2007. Retrieved 28 February 2014.

- [24] Prakash, Sahoo, Jaya. Analysis of ECG signal for Detection of Cardiac Arrhythmias, N.p.: n.p., n.d., Web.
- [25] P. de Chazal, R.B. Reilly, "A patient-adapting heartbeat classifier using ECG morphology and heartbeat interval feature," IEEE Trans. Biomed. Eng. vol. 53, pp. 2535-2543, 2006.
- [26] Simon Haykin, Neural networks a comprehensive foundation, Pearson Prentice Hall, pp.178-330
- [27] MIT-BIH Database distribution, Massachusetts Institute of Technology, 77 Massachusetts Avenue, Cambridge, MA 02139,1998. <http://www.physionet.org/physiobank/database/mitdb>.
- [28] Mietus, J E; Peng, C.K.; Henry, I.; Goldsmith, R.L.; Goldberger, A.L. (2002). "The pNNx files: re-examining a widely used heart rate variability measure". Heart 88: 378-380.doi:10.1136/heart.88.4.378
- [29] Sayers BM. Analysis of heart rate variability. Ergonomics. 1973;16:17-32 Luczak H, Lauring WJ. An analysis of heart rate variability. Ergonomics.1973;16:85-97.
- [30] Malik M, Farrell T, Cripps T, Camm AJ. Heart rate variability in relation to prognosis after myocardial infarction: selection of optimal processing techniques. Eur Heart J. 1989;10:1060-1074.
- [31] Clinton F. Goss; Eric B. Miller (August 2013). "Dynamic Metrics of Heart Rate Variability". arXiv:1308.6018
- [32] Isler, Yalcin; Kuntalp, M. (2007). "Combining classical HRV indices with wavelet entropy measures improves to performance in diagnosing congestive heart failure". Computers in Biology and Medicine 37 (10): 1502-1510. doi:10.1016/j.compbiomed.2007.01.012
- [33] Kanters JK, Holstein-Rathlou NH, Agner E (1994). "Lack of evidence for low-dimensional chaos in heart rate variability". Journal of Cardiovascular Electrophysiology 5 (7):591-601.doi:10.1111/j.1540-8167.1994.tb01300.x.
- [34] Brennan M,Palaniswami M, Kamen P. Do existing measures of Poincare plot geometry reflect non-linear features of heart rate variability? Biomedical Engineering, IEEE Transactions on, Proc. IEEE Transactions on Biomedical Engineering, 2001, 48, 1342-1347
- [35] Storella RJ, Wood HW, Mills KM et al. (1994). "Approximate entropy and point correlation dimension of heart rate variability in healthy subjects". Integrative

Physiological & Behavioral Science 33 (4): 315–20. doi:10.1007/BF02688699.
PMID 10333974

- [36] C.-K. Peng, J. Mietus, J. M. Hausdorff, S. Havlin, H. E. Stanley, A. L. Goldberger; Mietus, J.; Hausdorff, J.; Havlin, S.; Stanley, H.; Goldberger, A. (1993). "Long-range anticorrelations and non-gaussian behavior of the heartbeat". *Phys. Rev. Lett* 70 (9): 1343–6. doi:10.1103/PhysRevLett.70.1343 PMID 10054352
- [37] *Circulation*. 1996;93:1043-1065. doi: 10.1161/01.CIR.93.5.1043
- [38] Steele, (2012, March 26). 9 Life-Saving Technologies for Doctors [Online]. Available: <http://www.pcmag.com/slideshow/story/295802/9-new-life-saving-technologies-for-doctors/1>
- [39] Healthcare IT, (May 10, 2011), Isansys Lifecare Launches LifeTouch [Online], Available:<http://mwr.com/content/band-aid-heart-monitor-makes-easy-work-ecgs-while-collaborations-advance-communications>.
- [40] <http://www.biomedsys.com/truview/pdfs/truVueData.pdf>
- [41] Young Rhee, Man. GSM: Global system for Mobile Communications. Valbonne, France: Institute, 1996. Web.
- [42] "Smarttechnologiesupdate." Smarttechnologiesupdate, Muradishita in Cellular Technology.,n.d. Web. 29 Oct. 2014.
- [43] "Maailman ensimmäinen GSM-puhelu" [World's first GSM call]. yle.fi. Yelisradio OY. 22 February 2008. Archived from the original on 5 May 2011. Retrieved 5 May 2011. "Harri Holkeri made the first call on the Radiolinja (Elisa's subsidiary) network, at the opening ceremony in Helsinki on 07.01.1991."
- [44] Sauter, Martin (21 Nov 2013). "The GSM Logo: The Mystery of the 4 Dots Solved". Retrieved 23 Nov 2013. "[...] here's what [Yngve Zetterstrom, rapporteur of the Marketing and Planning (MP) group of the MoU (Memorandum of Understanding group, later to become the GSM Association (GSMA)) in 1989] had to say to solve the mystery: '[The dots symbolize] three [clients] in the home network and one roaming client.' There you go, an answer from the prime source!"
- [45] "Cellular History". etsi.org. European Telecommunications Standards Institute. 2011. Archived from the original on 5 May 2011. Retrieved 5 May 2011. "The task was entrusted to a committee known as Groupe Spécial Mobile (GSMTM), aided by a 'permanent nucleus' of technical support personnel, based in Paris."
- [46] "E.C.G. Interpretation By Computer." *The British Medical Journal* 3.5933 (1974): 702. Web.

- [47] Technology, Microchip. (n.d.): n. pag. Web.
- [48] "PIC16F877A." - 8-bit PIC® Microcontrollers. N.p., n.d. Web. 29 Oct. 2014.
- [49] An Iso/ts 16949, Iso 9001 And Iso 14001 Certified Company. Continental Device India Limited (n.d.): n. pag. Web.
- [50] "REGULATOR IC 7909 Datasheet." Datasheet & Application Note. N.p., n.d. Web. 29 Oct. 2014.
- [51] "Services | Embedded Support | Reviews | Virtual Technologys." Interfacing LCD with PIC16F877A in MPLAB X -. N.p., n.d. Web. 29 Oct. 2014.
- [52] "Interfacing GSM Module with PIC Microcontroller - NBCAFE." NBCAFE. N.p., n.d. Web. 29 Oct. 2014.
- [53] Phyllis, K., Kleiger, M. D., Robert, E., Rottman, M. D., & Jeffrey, N. (1997). Differing effects of age on heart rate variability in men and women. *The American journal of cardiology*, 80(3), 302-305.
- [54] Johns Hopkins Medicine. Vital signs (body temperature, pulse rate, respiration rate, blood pressure). Baltimore, US: Johns Hopkins Health Library. Information published online, accessed February 11th, 2014.
- [55] "Texas Instruments." *ADS1293*. Texas Instrument, Mar. 2013. Web.

Appendix:

Transmitter side coding:

HRV Display coding

sbit LCD_RS at RE0_bit;

sbit LCD_RW at RE1_bit;

sbit LCD_EN at RE2_bit;

sbit LCD_D4 at RB4_bit;

sbit LCD_D5 at RB5_bit;

sbit LCD_D6 at RB6_bit;

sbit LCD_D7 at RB7_bit;

sbit LCD_RS_Direction at TRISE0_bit; sbit

LCD_RW_Direction at TRISE1_bit; sbit

LCD_EN_Direction at TRISE2_bit;

sbit LCD_D4_Direction at TRISB4_bit;

sbit LCD_D5_Direction at TRISB5_bit;

sbit LCD_D6_Direction at TRISB6_bit;

sbit LCD_D7_Direction at TRISB7_bit;

Heart rate alert coding

```
if(time < 50 || time > 100){
    Lcd_Out(2, 1, CRITICAL);
    if(!critical)
        doMsg(rate);
    critical = 1;
}
else{
    critical = 0;
    if(time < 60){
        Lcd_Out(2, 1, EXCELLENT);
    }
    else if(time < 70){ Lcd_Out(2,
        1, NORMAL);
    }
    else if(time < 82){ Lcd_Out(2,
        1, AVERAGE);
    }
    else{
        Lcd_Out(2, 1, POOR);
    }
}
```



```
}  
}
```

GSM coding

```
char* AT = "AT";
```

```
char* AT_CMFG = "+CMGF=1";
```

```
char* AT_CMGS = "+CMGS=";
```

```
char* AT_DOBLE = "\"";
```

```
char CTRLZ = 0x1A; char*
```

```
NEW_LINE = "\n\r";
```

```
char* RECEIVER1 = "+14044262349";
```

```
char* RECEIVER2 = "+14797995005";
```

```
void sentSMS(char* buffer, unsigned int rate){
```

```
    UART1_Write_Text(AT);
```

```
    UART1_Write_Text(NEW_LINE); Delay_ms(100);
```

```
    UART1_Write_Text(AT);
```

```
    UART1_Write_Text(AT_CMFG);
```

```
UART1_Write_Text(NEW_LINE); Delay_ms(100);
```

```
UART1_Write_Text(AT);
```

```
UART1_Write_Text(AT_CMGS);
```

```
UART1_Write_Text(AT_DOBLE);
```

```
UART1_Write_Text(buffer);
```

```
UART1_Write_Text(AT_DOBLE);
```

```
UART1_Write_Text(NEW_LINE); Delay_ms(100);
```

```
UART1_Write_Text(AT_DOBLE);
```

```
UART1_Write_Text(CRETICAL);
```

```
UART1_Write_Text(NEW_LINE);
```

```
UART1_Write_Text(HEART_RATE);
```

```
if(rate > 100){ UART1_Write('1');
```

```
    rate %= 100;
```

```
}
```

```
UART1_Write('0' + rate / 10); UART1_Write('0' +
```

```
rate % 10);
```

```

    UART1_Write_Text(AT_DOBLE);
    UART1_Write_Text(CTRLZ);
    UART1_Write_Text(NEW_LINE);
    Delay_ms(100);
}
void doMsg(unsigned int rate){
    sentSMS(RECEIVER1, rate);
    sentSMS(RECEIVER2, rate);
}

```

Coding for receiver section GSM

receiver coding

```
Private Sub Command1_Click() End
```

```
End Sub
```

```
Private Sub Form_Load()
```

```
MSComm1.PortOpen = True Sleep
```

```
(20)
```

```
End Sub
```

```
Private Sub Timer1_Timer()
```

```
MSComm1.Output = "AT+CMGR=1" & Chr$(13)
```

```
Sleep (200)
```

```
RStr = MSComm1.Input
```

```
Label3.Caption = RStr
```

```
s = InStr(1, RStr, "(")
```

```
If InStr(1, RStr, "(") Then
```

```
If InStr(s + 1, RStr, ")") Then chk1
```

```
= InStr(1, RStr, "(")
```

```
chk2 = InStr(chk1 + 1, RStr, ")")
```

```
Text1.Text = Mid$(RStr, chk1 + 1, chk2 - (chk1 + 1))
```

```
Sleep (100)
```

```
MSComm1.Output = "AT+CMGD=1" & Chr$(13)
```

```
Sleep (200)
```

```
Label3.Caption = MSComm1.Input
```

```
End If
```

```
End If
```

```
If Val(Text1.Text) > 100 Then
```

```
Label4.Caption = "ABNORMAL"
```

```
End If
```

End Sub



October 6, 2014

MEMORANDUM

TO: Vijay Varadan
Mouli Ramasamy
Prashanth Shyamkumar
Sairaj Kistnam Setty

FROM: Ro Windwalker
IRB Coordinator

RE: PROJECT CONTINUATION & MODIFICATION

IRB Protocol #: 11-09-093

Protocol Title: *Smart Textile Sensor System for Health Monitoring*

Review Type: EXEMPT EXPEDITED FULL IRB

Previous Approval Period: Start Date: 09/28/2011 Expiration Date: 09/27/2014

New Expiration Date: 09/27/2015

Your request to extend and modify the referenced protocol has been approved by the IRB. If at the end of this period you wish to continue the project, you must submit a request using the form *Continuing Review for IRB Approved Projects*, prior to the expiration date. Failure to obtain approval for a continuation on or prior to this new expiration date will result in termination of the protocol and you will be required to submit a new protocol to the IRB before continuing the project. Data collected past the protocol expiration date may need to be eliminated from the dataset should you wish to publish. Only data collected under a currently approved protocol can be certified by the IRB for any purpose.

This protocol has been approved for 100 total participants. If you wish to make *any* modifications in the approved protocol, including enrolling more than this number, you must seek approval *prior to* implementing those changes. All modifications should be requested in writing (email is acceptable) and must provide sufficient detail to assess the impact of the change.

If you have questions or need any assistance from the IRB, please contact me at 210 Administration Building, 5-2208, or irb@uark.edu.

210 Administration Building • 1 University of Arkansas • Fayetteville, AR 72701
Voice (479) 575-2208 • Fax (479) 575-3846 • Email irb@uark.edu

The University of Arkansas is an equal opportunity/affirmative action institution.