

## University of Arkansas, Fayetteville ScholarWorks@UARK

---

### Patents Granted

---

10-29-1991

# Drive system employing frictionless bearings including superconducting matter

David E. Weeks II

*University of Arkansas, Fayetteville*

Follow this and additional works at: <http://scholarworks.uark.edu/pat>

---

### Recommended Citation

Weeks, David E. II, "Drive system employing frictionless bearings including superconducting matter" (1991). *Patents Granted*. 251.  
<http://scholarworks.uark.edu/pat/251>

This Patent is brought to you for free and open access by ScholarWorks@UARK. It has been accepted for inclusion in Patents Granted by an authorized administrator of ScholarWorks@UARK. For more information, please contact [scholar@uark.edu](mailto:scholar@uark.edu), [ccmiddle@uark.edu](mailto:ccmiddle@uark.edu).

[54] **DRIVE SYSTEM EMPLOYING FRICTIONLESS BEARINGS INCLUDING SUPERCONDUCTING MATTER**

[75] **Inventor:** David E. Weeks, II, Fayetteville, Ark.

[73] **Assignee:** The University of Arkansas, Little Rock, Ark.

[21] **Appl. No.:** 325,300

[22] **Filed:** Mar. 17, 1989

[51] **Int. Cl.<sup>5</sup>** ..... H01L 39/12

[52] **U.S. Cl.** ..... 505/1; 310/52; 310/90.5; 250/231.13; 335/126

[58] **Field of Search** ..... 310/10, 40 R, 52, 90.5, 310/156, 154; 250/231 SE; 318/254, 480; 335/126; 505/1, 700

[56] **References Cited**

**U.S. PATENT DOCUMENTS**

3,025,151	3/1962	Buchhold	.....	310/40 R
4,545,209	10/1985	Young	.....	310/90.5
4,726,640	2/1988	Iwama	.....	310/90.5
4,797,386	1/1989	Gyorgy et al.	.....	335/216
4,820,950	4/1989	Hijiya	.....	310/90.5
4,886,778	12/1989	Moon et al.	.....	310/90.5

**FOREIGN PATENT DOCUMENTS**

1283946	11/1968	Fed. Rep. of Germany	.....	310/90.5
---------	---------	----------------------	-------	----------

**OTHER PUBLICATIONS**

"Levitation of a Magnet Over a Flat Type II Superconductor", J. Appl. Phys. 63(2), Jan. 15, 1988.

"Levitation Effects Involving High T<sub>c</sub> Thallium Based Superconductors", Appl. Phys. Lett. 53(12), Sep. 19, 1988.

*Primary Examiner*—R. Skudy

*Attorney, Agent, or Firm*—Hermann Ivester, Hill, Van Santen, Steadman and Simpson

[57] **ABSTRACT**

A device employing frictionless bearings including a mass of superconductor material having a superconducting temperature T<sub>c</sub> above about 77° K., magnet having an axis of symmetry being levitated from said mass of superconductor material so as to be rotatable about its axis of symmetry, and a support member attached to the magnet, the support member being driven so as to cause the magnet to rotate about its axis of symmetry.

Additionally, there is included a frictionless commutator wherein a signal beam is intermittently interrupted by a member attached to the magnet, such intermittent interruption of the beam being detected and employed to cause alternate energization and de-energization of a solenoid which, in turn, creates a magnetic field. The solenoid magnetic field is employed to attract and repel second magnets positioned about the member so as to rotatably drive the first magnet.

**11 Claims, 2 Drawing Sheets**

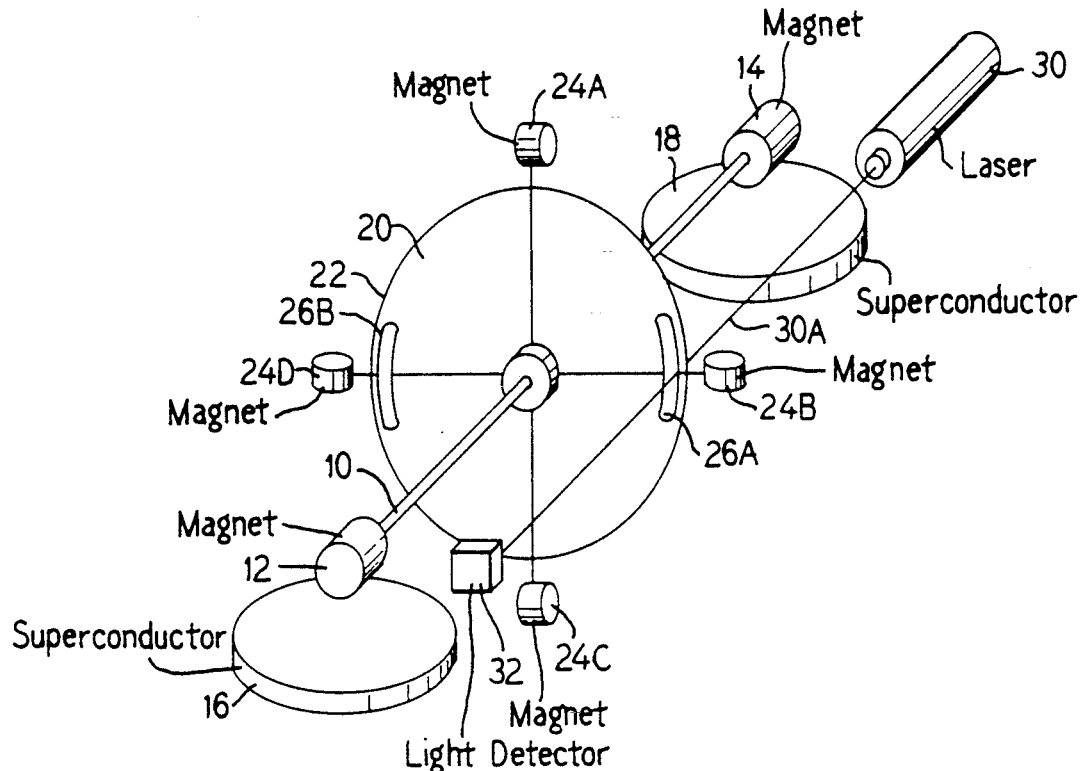

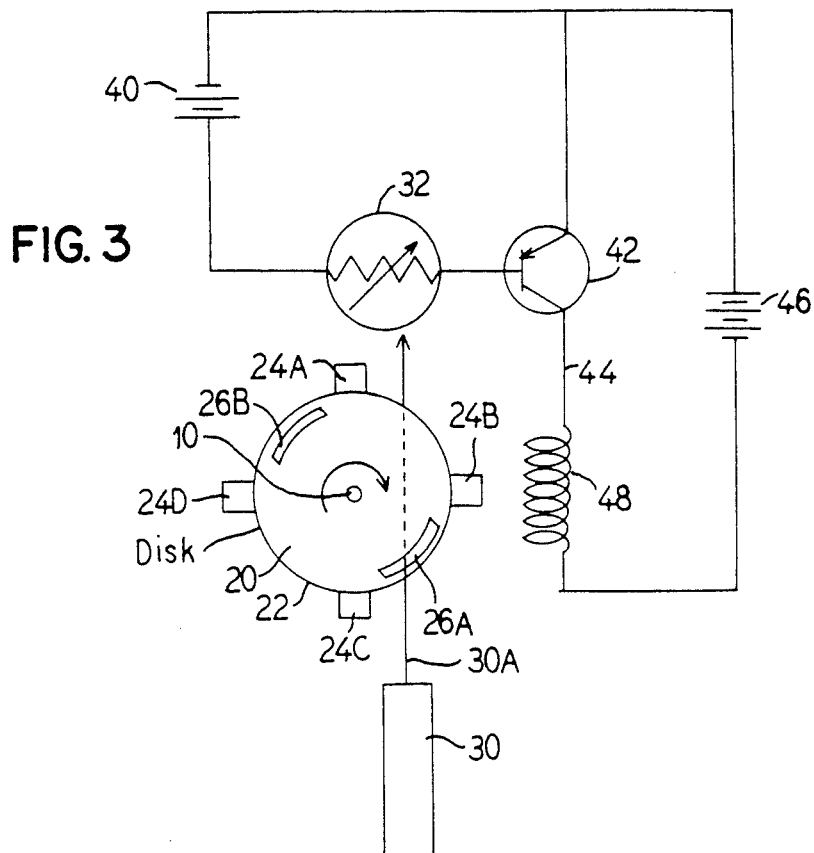
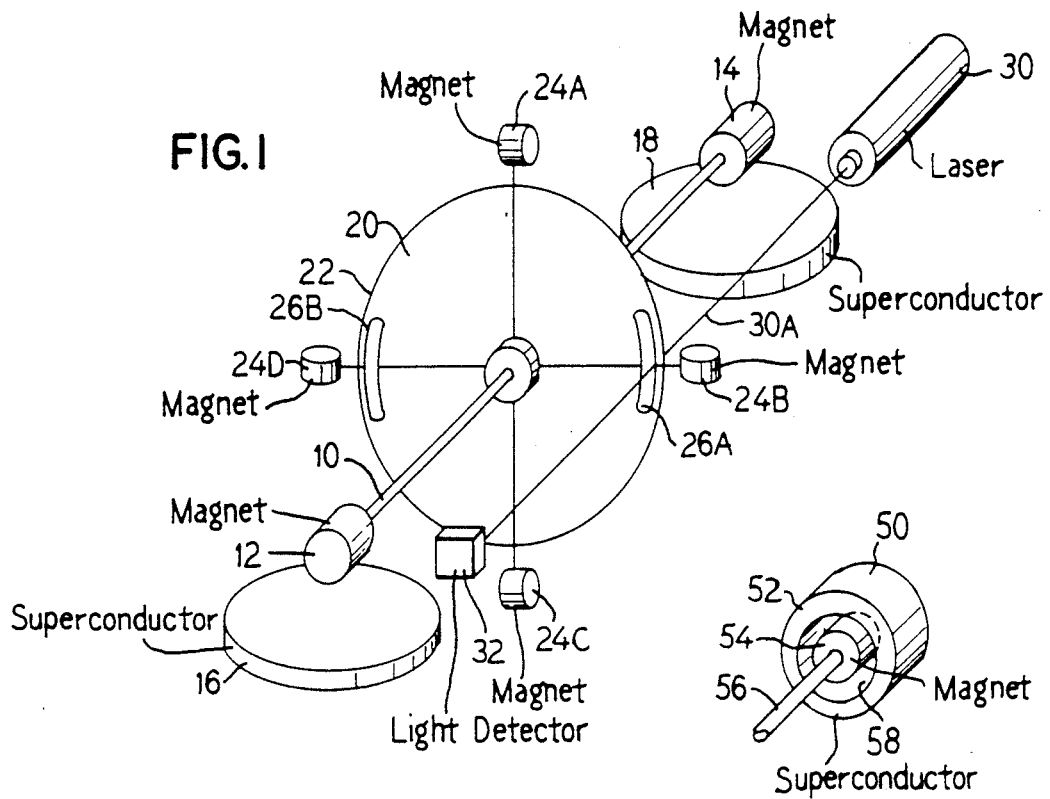

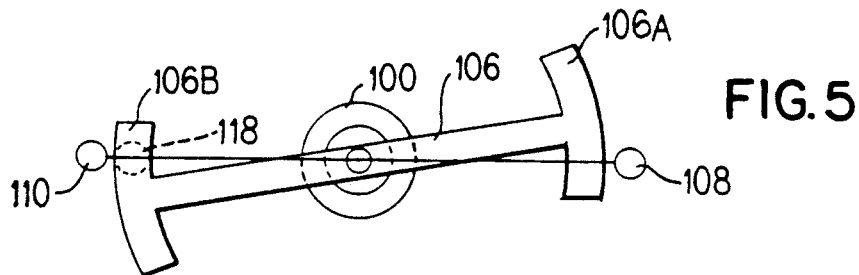
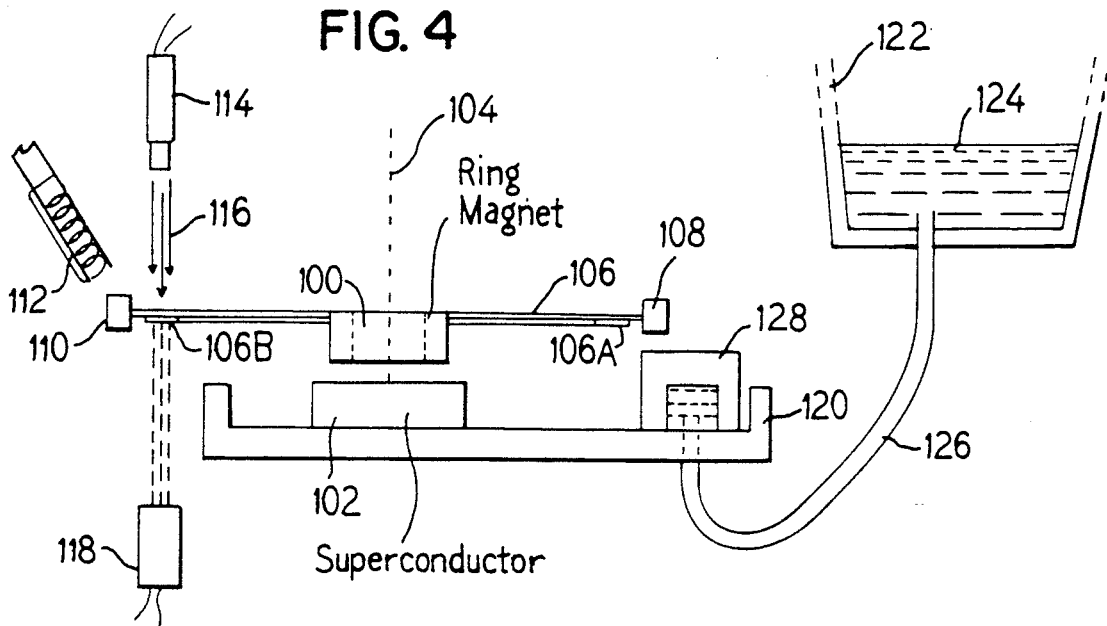

**FIG. 6**  
(PRIOR ART)

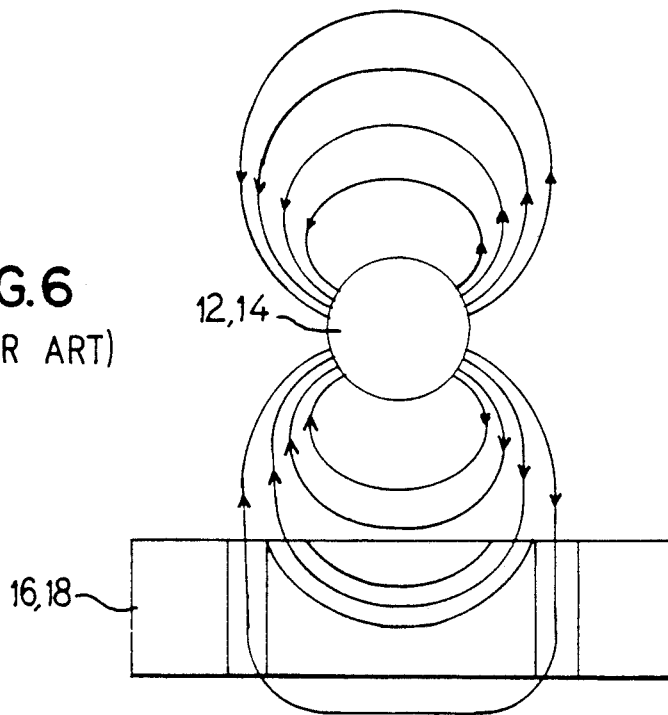

## DRIVE SYSTEM EMPLOYING FRICTIONLESS BEARINGS INCLUDING SUPERCONDUCTING MATTER

### BACKGROUND OF THE INVENTION

The present invention is generally directed to devices employing ceramic superconducting matter with a transition temperature  $T_c$  above about 30° K. Additionally, the present invention is directed to drive systems.

In presently employed drive systems that utilize a rotating axle or shaft, the axle is directly or indirectly supported by rotating bearings. The bearings are employed, to provide a reduced friction surface on which the axle rotates. However, because there still is friction between the rotating axle and the bearings, albeit a reduced amount, the bearings and axle are subject to wear. Accordingly, the efficiency of a system used to drive the axle is reduced not only by the original friction, but also by the further friction induced by the wearing of the parts.

In connection with electrical motors, commutators are employed to couple a power source to windings on the rotating shaft. When supplied with electrical power, the shaft winds act as magnetic poles and react with cooperating stationary magnets or windings so as to cause the shaft to rotate. Because the commutators engage a rotating part, the commutators are subject to extreme wear and must be replaced from time to time. The friction between the commutators and the rotating parts also decreases the efficiency of the motors due to the power required to overcome the friction.

### SUMMARY OF THE INVENTION

The present invention provides a rotatably driven support member supported by at least one frictionless bearing. To this end, the invention utilizes superconducting matter to levitate at least one magnet connected to the support member, which magnet, based on current understanding, induces persistent currents in the superconducting matter. The persistent currents in the superconducting matter create magnetic flux lines that repel the magnet to thereby repel and levitate same. Certain of the flux lines penetrate the magnet and create vortices that provide lateral stability to the magnet so as to maintain the magnet in a specified position.

The invention also provides a frictionless commutator that is employed in cooperation with the drive system that rotatably drives the support member. A signal beam is operatively oriented so as to traverse a member attached to the support member that intermittently cuts off the signal beam. An appropriate signal beam detector operatively drives a solenoid in response to detection of the signal beam. The solenoid cooperates with magnets attached to the support member so as to operatively impel and/or repel same to cause the support member to rotate.

In an embodiment, the invention includes cylindrical cobalt-samarium (Co-Sm) magnets located at ends of a shaft, the axes of the magnets aligning with the axis of the shaft. Each of the Co-Sm magnets is positioned above a mass of copper oxide perovskite matter so that persistent currents are induced by the Co-Sm magnets in the copper oxide perovskite matter, the persistent currents creating magnetic fields opposing the fields of the Co-Sm magnets.

In an embodiment of the drive system, an He-Ne laser is employed to direct a laser beam parallel to the shaft to

be driven. A photocell is positioned so as to detect the beam. A disk that extends radially from the shaft generally interrupts the laser beam. However, a pair of slots in the disk intermittently allow the beam to pass through the disk as the disk rotates with the shaft. The photocell fires intermittently with receipt of the laser beam to, in turn, drive an amplifier coupled thereto. The amplifier, when so driven, causes a high current to traverse through a solenoid coupled to the amplifier so as to cause energization of the solenoid. The solenoid provides a magnet that cooperates with magnets mounted on the periphery of the disk so as to cause rotation thereof. The speed of rotation is controlled by proximity of the solenoid to the disk magnet and the amount of current sent to the solenoid.

Accordingly, an advantage of the invention is the employment of a frictionless bearing for a rotating shaft.

Another advantage of the invention is the provision of a frictionless commutator system for a motor.

Yet another advantage of the invention is the provision of bearings that require a minimum of applied torque to cause rotation of a rotatable part.

Yet a further advantage of the invention is an easy to produce, low-cost bearing arrangement that favorably competes on economic terms with other light weight, low friction bearings.

These and other advantages will become apparent from the following description of the preferred embodiments thereof, taken in conjunction with the accompanying drawings.

### BRIEF DESCRIPTION OF THE DRAWINGS

FIG. 1 is a perspective view of an apparatus employing principles of the invention;

FIG. 2 is a perspective view of a bearing arrangement of a portion of a further device embodying principles of the invention;

FIG. 3 is an electrical schematic of a solenoid circuit for driving the arrangement of FIG. 1;

FIG. 4 is a diagram illustrating an alternate embodiment of the invention;

FIG. 5 is a top view of a portion of the embodiment illustrated in FIG. 4 taken generally along the line V-V; and

FIG. 6 is an elevational illustration of a magnet levitating above a superconductor mass including an illustration of the magnetic flux lines generated thereby.

### DETAILED DESCRIPTION OF THE PRESENTLY PREFERRED EMBODIMENTS

In FIG. 1 there is illustrated an apparatus embodying principles of the invention. The apparatus includes a shaft 10. On opposite ends of the shaft 10 are positioned and attached two cylindrical cobalt-samarium (Co-Sm) magnets 12 and 14, the axes of which are aligned and in registry with the axis of the shaft 10. Each of the magnets 12 and 14 is positioned above a mass of superconducting matter 16 and 18 (each being referred to hereinafter as a superconductor), respectively, preferably shaped as a disk. As such, the shaft 10 serves as a support member.

The superconductors masses 16 and 18 comprises any of the new class of copper oxide perovskite superconductors with a superconducting transition temperature  $T_c$  greater than 77° K. Based on current understanding, the magnets 12 and 14 are magnetically levitated by means of persistent currents generated in the supercon-

ductors 16 and 18, respectively, which, in turn, generate magnet fields that oppose the fields of the magnets 12 and 14. The persistent currents are induced by the two cylindrical magnets 12 and 14.

It can be appreciated that because the magnets 12 and 14 are levitated above the superconductors 16 and 18, respectively, the shaft 10 is levitated above its mount (in this case the superconducting disks 16 and 18). As a result, the shaft 10 does not frictionally engage its mount. Thus, the superconducting matter-magnet arrangement illustrated, creates two ultra-low to no friction bearings about which the shaft 10 may be easily rotated under the influence of a variety of driving mechanisms. The use of the superconductor bearings permits a levitated object to spin with a minimum of applied torque, offering an advantage over conventional bearings that, by definition, operate with friction.

As illustrated in FIG. 6, each of the magnets 12 and 14 is constrained within a given position by means of flux line vortices extending through the magnets 12 and 14 and the respective superconductors 16 and 18. It has been observed, as discussed in an article written by F. Hellman et al., entitled "*Levitation of a Magnet Over a Flat Type II Superconductor*," and published at 62 J. Appl. Phys. 447-450, (Jan. 15, 1988), that energy is required to move a magnet positioned above (or below) a type II superconductor. As such, it can be appreciated that the magnetic flux interaction between a magnet and superconductor alone constrains the magnets 12 and 14 within a given position and thereby provides lateral stability to same.

Essentially, as a magnet placed above a superconductor is moved, the pinned current vortices must move also. But it takes energy to move these vortices. However, rotation of a magnet, such as a cylinder or ring-shaped magnet about an axis of symmetry, is not affected by such flux trapping because the magnetic field is by definition invariant under such rotation. It can be appreciated that the use of such flux trapping for stabilizing levitated magnets is more simple and less expensive than the electromagnetic servo-mechanisms.

Although not illustrated, it is understood by those of skill in the relevant art, that due to the presence of the flux line vortices, the magnet illustrated in FIG. 6 can be levitated in inverted fashion (inverted levitation), whereby the magnet is suspended relatively below the superconductor. That is to say, the superconductor in FIG. 6 need only be rotated, by any amount, even by 180 degrees, and the magnet will still be positioned in the same vortices. Accordingly, the magnet can be levitated from the superconductor either relatively above, below, or to the sides of same. Thus, the terms levitation or levitated are used only in a relative sense throughout this specification and the claims, unless otherwise noted.

As illustrated in FIG. 2, it is also possible to construct a superconductor 50 as to have an annular wall 52. A cylindrical magnet 54 attached to a shaft 56 can then be located within an interior 58 of the superconductor 50. Such an arrangement can provide yet greater lateral stability to the magnet 54 as a local potential minimum position would be formed along the central axis of the superconductor 50.

As further illustrated in FIGS. 1 and 3, the apparatus includes a disk 20 mounted on the shaft 10 such that the axis of the shaft 10 penetrates the center of the disk 20. Positioned about a periphery 22 of the disk 20, are four cobalt samarium magnets 24A-24D. The rotating disk is

generally of a solid, non-light transmissive material and includes four slots 26A and 26B positioned in proximity with the periphery 22 of the disk 20. The magnets 24A-24D and slots 26A and 26B are utilized in cooperation with the driving system for the shaft 10.

The apparatus includes a laser 30, preferably a helium-neon laser, that is utilized to direct a signal, in this case a columnated beam of light or laser beam 30A, parallel to the axis of the shaft 10. The laser 30 is positioned at one end of the shaft 10, while a photocell or light detector 32 is positioned at the other end of the shaft 10. The photocell 32 detects the emission of the laser beam 30A by the laser 30.

As is illustrated in the figures, the laser beam 30A is directed at the rotating disk 20 such that as the disk 20 rotates in cooperation with the shaft 10. The slots 26A and 26B intermittently allow the laser beam 30A to pass through the disk 20. As such, the slots 26A and 26B and the disk 20 cooperate to act as a laser beam chopper.

As is illustrated most clearly in FIG. 3, the photocell 32 is placed in a series circuit with a power supply 40 and an amplifier 42. It can be appreciated that when the photocell 32 receives or detects emission of the laser beam 30A, the photocell 32 allows current to conduct in the circuit from the power supply 40 to the base or drive of the amplifier 42 to thereby cause the amplifier 42 to create a large current draw through the wires 44. The amplifier 42 is powered by a second power supply 46.

As illustrated, the amplifier 42 causes current to be drawn through a solenoid 48. Because the solenoid 48 is located in proximity to the periphery of the disk 20, the solenoid 48 cooperates with the magnets 24A-24D to cause the disk 20 to rotate. As illustrated in FIG. 3, the magnets 24A-24D are arranged so that the disk 20 rotates in a clockwise direction. To this end, the magnets 24A-24D are positioned such that the south poles thereof are directed into the direction of rotation. In turn, the solenoid is positioned so that the north pole thereof aligns with the north poles of the magnets 24A-24D after the magnets have rotated past the solenoid. Accordingly, the north poles repel and cause the disk 20 to rotate. At the same time, the solenoid attracts the south pole of a magnet approaching the solenoid 48.

It can be appreciated that the use of the illustrated drive system creates a frictionless laser commutator. There are no parts of the commutator which frictionally engage the rotating shaft 10 or rotating disk 20. The use of the laser commutator avoids the inherent friction and wear of the conventional contact commutators. The use of the low power laser beam provides an effective electromagnetic switching and permits quick and easy alignment of the photocell 32, disk 20, and laser 30.

It can further be appreciated that the rotational velocity of the disk 20 is controlled by the placement of the solenoid 48 and the amount of current sent to the solenoid 48. That is to say, the closer the solenoid 48 is placed to the disk 20, the stronger are the repulsion and the attraction forces created between the solenoid 48 and the magnets 24A-24D.

Yet further, it can be appreciated that the number of slots, number of magnets 24A-24D, and solenoids 48 can be varied so as to provide different operating characteristics to the drive mechanism. Also, the laser beam need not be directed exactly parallel to the axis of rotation of the disk, so long as the beam is intermittently interrupted by a member in cooperation with the rotation of the shaft 10.

In FIG. 4 there is illustrated an alternate embodiment of the invention, wherein a ring magnet 100 is levitated above a superconductor 102 in accordance with the principles of the invention. As illustrated, the ring magnet 100 rotates about an axis of symmetry 104 that is oriented perpendicularly relative to the superconductor 102. Accordingly, the ring magnet 100 is in a position that is at a right angle to the position of either the magnets 12 or 14 of the embodiment illustrated in FIG. 1.

In the embodiment illustrated in FIG. 4, the support arm 106 is supported on or by the magnet 100. Accordingly, the support arm 106 rotates about the axis 104 above the superconductor 102. It can be appreciated that various other support arms or elements can be mounted on the ring magnet 100 or the support arm 106 so as to co-rotate therewith. Such support arms or elements could include a shaft extending along the axis 104.

To drive the arrangement illustrated in FIGS. 4 and 5, an arrangement similar to that described in connection with FIGS. 1 and 3 is employed. To this end, a pair of magnets 108 and 110 are located at ends of the support arm 106, which magnets are retracted and repelled by means of a solenoid 112 connected to the circuit similar to that illustrated in FIG. 3. The solenoid 112 functions in a manner similar to the solenoid 48.

Additionally, the support arm 106 includes two members 106A and 106B located at axial ends of the arm 106, which members serve as photo-interrupters. As illustrated, a laser 114 is employed to generate a laser signal 116 that is detected by a photo-detector 118. The members 105A and 106B intermittently interrupt the signal 116 so as to cause the solenoid 112 to energize and de-energize, as discussed above.

Also illustrated in FIG. 4, is an arrangement for supplying a coolant, such as liquid nitrogen, about the superconductor 102, when the superconductor 102 is in a horizontal position relative to the earth. To this end, the arrangement includes a dish 120 within which the superconductor 102 rests. Located vertically above the dish 120 is a reservoir 122 containing a supply of liquid nitrogen 124. The supports for the dish 120 and reservoir 122 are not illustrated inasmuch as they are considered obvious to those of ordinary skill in the relevant art.

A feed tube 126 is employed as a conduit between the reservoir 122 to the dish 120. The liquid nitrogen 124 flows into the dish 120 by means of the conduit 126. A baffle 128, preferably made out of cork, is placed above the discharge end of the tube 126 within the dish 120 so as to regulate the discharge of the liquid nitrogen into the dish 120. This baffle prevents the liquid nitrogen from splashing about. Furthermore, by restricting the inflow of liquid nitrogen, the baffle 128 serves to prevent the liquid nitrogen from overflowing out of the dish 120, thereby reducing waste of same.

As is well-known in the relevant art, the superconductor 102 must be kept to below a maximum critical temperature, which temperature varies depending on the superconductor material employed. Accordingly, the liquid nitrogen serves this purpose when it fills the inside of the dish about the superconductor 102. It can also be appreciated that because the levitation of a magnet from a mass of type II superconductor is relative, a drive system can also be designed, wherein the magnet is held fixed while a superconductor is free to rotate. Accordingly, one need only construct the system so

that the superconductor has an axis of symmetry. A support member is then attached to the superconductor.

While a preferred embodiment has been illustrated, many other modifications and variations which fall within the spirit and scope of the invention will be obvious to those skilled in the art. It is intended that those modifications and variations be covered also by the attached claims.

We claim:

1. An apparatus comprising:
  - (a) a rotatable support member;
  - (b) a pair of first magnets positioned at opposite ends of the support member, said magnets having axes of symmetry and being rotatable about said axes;
  - (c) a mass of a superconducting material positioned adjacent each first magnet so that based on current understanding each magnet is levitated from the mass of superconducting material by means of persistent currents induced in the mass of superconducting material by said first magnets.
2. The apparatus of claim 1, wherein the first magnets are made of cobalt samarium.
3. The apparatus of claim 1, wherein the first magnets are cylindrically shaped, the axes of which are aligned with the support member.
4. The apparatus of claim 1, wherein the mass of superconducting material is made of a copper oxide perovskite material having a superconducting temperature  $T_c$  that is greater than about 77° K.
5. The apparatus of claim 1, including second magnets mounted about the support member and a solenoid positioned in proximity with the second magnets so that intermittent energization of the solenoid by means of a power source coupled thereto operatively repulses and attracts the second magnets to cause rotation of the support member.
6. The device of claim 1, wherein the mass of superconducting material is disk shaped.
7. A device, comprising:
  - a magnet having an axis of symmetry;
  - a support member attached to said magnet; and
  - a mass of superconducting material located adjacent said magnet so that based on current understanding persistent currents are induced in the mass of superconducting material by the magnet so as to cause the magnet to be levitated from the mass of superconducting material, said magnet being freely rotatable about its axis of symmetry, the mass of superconducting material being made of a copper oxide perovskite material having a superconducting temperature above about 77° K.
8. The device of claim 7, wherein the magnet is made of cobalt samarium and is cylindrically shaped.
9. An apparatus, comprising:
  - (a) a pair of superconductors made of a superconducting material of copper oxide perovskite and having a superconducting temperature above about 77° K.;
  - (b) a pair of cylindrically shaped first magnets made of cobalt samarium positioned about the superconductors, one of said first magnets positioned above each superconductor, each of said first magnets being supported above its respective superconductor, based on current understanding, by means of magnet fields created by persistent current induced by the first magnets in each superconductor;
  - (c) a shaft supported by the first magnets, one of said first magnets attached to each end of the shaft;

7

- (d) a plurality of second magnets attached in a circle about the shaft;
- (e) a laser beam generator;
- (f) a light detector operatively associated with the laser beam generator so as to detect beams emitted by the laser beam generator;
- (g) means mounted about the shaft for intermittently interrupting a beam generated by the laser beam generator; and
- (h) a solenoid operatively associated with the light detector so that detection of the beam by the light detector causes energization of the solenoid, the

5

10

8

solenoid being operatively positioned in proximity to the second magnets so as to repel and attract the second magnets to cause the shaft to rotate.

10. The apparatus of claim 9, wherein the means for intermittently interrupting the beam comprises a disk mounted about the shaft, the disk generally interrupting transmission of the beam and having apertures through which the beam intermittently passes.

11. The apparatus of claim 10, wherein the second magnets are positioned about a periphery of the disk.

\* \* \* \* \*

15

20

25

30

35

40

45

50

55

60

65