Theses

2016

Towards the identification of metabolite markers of nipple pain and inflammation in human milk

Erin Fee

University of Notre Dame Australia

Follow this and additional works at: <https://researchonline.nd.edu.au/theses>



Part of the [Life Sciences Commons](#), and the [Medicine and Health Sciences Commons](#)

COMMONWEALTH OF AUSTRALIA
Copyright Regulations 1969

WARNING

The material in this communication may be subject to copyright under the Act. Any further copying or communication of this material by you may be the subject of copyright protection under the Act.

Do not remove this notice.

Publication Details

Fee, E. (2016). Towards the identification of metabolite markers of nipple pain and inflammation in human milk (Master of Philosophy (School of Health Sciences)). University of Notre Dame Australia. <https://researchonline.nd.edu.au/theses/123>

This dissertation/thesis is brought to you by ResearchOnline@ND. It has been accepted for inclusion in Theses by an authorized administrator of ResearchOnline@ND. For more information, please contact researchonline@nd.edu.au.





THE UNIVERSITY OF
NOTRE DAME
A U S T R A L I A

**Towards the Identification of Metabolite Markers
of Nipple Pain and Inflammation in Human Milk**

Erin Fee

Masters of Philosophy (Health Science)

Primary supervisor: Professor Naomi Trengove

Co-supervisors: Associate Professor Robert Trengove, Dr Joel Gummer,
Winthrop Professor Peter Hartmann, Research Associate Professor Donna Geddes
and Dr Ching Tat Lai

This thesis is presented as a requirement for Masters Of Philosophy in Health Science
research at the University of Notre Dame, Fremantle Western Australia

Submitted February 2016.

Acknowledgements

Thank you to Professor Naomi Trengove for her kind nature, honesty and encouragement. Thank you for persisting with me and providing the stern yet caring words that kept me going. Your determination and will power inspire me.

To the University of Notre Dame thank you for this wonderful opportunity and for the ongoing support and encouragement that a close-knit university provides. Thank you to the research office and all the health science staff members, with special mention to Professor Gerard Hoyne for his continuous interest and support of my project.

Thank you to Associate Professor Robert Trengove for your advice and guidance, your incredible knowledge of the metabolomics field is unmatched. Thank you for allowing me to be part of a world-class research group that is Metabolomics Australia. Thank you also to the other members of the group, specifically to Catherine Rawlinson for your constant help and assistance, you're a valued member of Metabolomics Australia.

To the Hartmann Human Lactation Research Group thank you for the opportunity and for planting the original seed which started my love of research and my endeavour to apply to the postgraduate program. To Winthrop Professor Peter Hartmann you're a wealth of knowledge, yet so humble and grounded, your advice and insight has been invaluable. Thank you to Research Associate Professor Donna Geddes and Dr Ching Tat Lai for your help getting my project off the ground, for your help with recruitment and with technical assistance. Thank you to Anna Hepworth for your statistical assistance and the time you spent teaching and advising me, you were forever patient.

I would like to acknowledge the generous financial support of Medela AG, without which my project would not have been possible.

Thank you to Senior Medical Scientist Cristina Farrar from Princess Margaret Hospital for your microbiology expertise and technical assistance for the bacteriology portion of my research. You were beyond helpful and I would have been lost without your guidance, thank you for taking me under your wing.

Thank you to all the donating mothers, many of which were in considerable amounts of pain yet still found the time and will to donate in the hope of helping other mothers in the future. Your individual stories and struggles touched me and gave me a new admiration for all mothers, your selflessness and generosity is greatly appreciated.

Thank you to my friends for their constant understanding and tenancy to keep in touch, it has been a tough year on friendship but I'm looking forward to spending time with you all now that I've finished.

To my partner Paul, thank you for your endless support and encouragement. Thank you for providing comfort when time spent with my family was scarce and trips home were few and far between. You have taught me that home isn't a place, but more so it's the people around you and I feel at home with you.

I'm forever grateful to my family, despite the large geographical distance between us I feel we are closer than ever. To my parents my voices of sanity and reassurance, the

reason I aspire to improve and better myself comes from you both. To my grandparents, your unconditional love and support has meant the world.

Finally to Dr Joel Paul Aloysius Gummer, you have played an irreplaceable role in my postgraduate experience. Thank you for your optimism, good humour and patience. Thank you for lifting my spirits in times of stress and for your constant reassurance when difficulties arose. I thank my lucky stars every day that I was lucky enough to be your first student, any future post-graduate students will be very fortunate to have you.

‘Up and at them’

Preface

The work in this thesis was supervised by Professor Naomi Trengove, University of Notre Dame Fremantle, Associate Professor Robert Trengove and Dr Joel Gummer, Metabolomics Australia at Murdoch University, and Winthrop Professor Peter Hartmann, Research Associate Professor Donna Geddes and Dr Ching Tat Lai, Hartmann Human Lactation Research Group at the University of Western Australia. My candidature was financially supported by Medela, AG, Baar, Switzerland.

Approvals

Human and Animal ethics was obtained through the University of Notre Dame and University of Western Australia.

Initial human ethics approval (ref number- 013014F) was received on the 21st of February 2013. Due to significant changes an ethics amendment was submitted and approval received on the 3rd of August 2013 (ref number 013014F)

Notification of use of animal tissue/cadaver approved 14th of November 2013, file reference number RA/3/500/ at the University of Western Australia listing Donna Geddes as chief investigator.

Facilities

The Hartmann Human Lactation Research Group provided the majority of equipment and materials required for bacterial and human milk analysis. Additional equipment for sample analysis was provided by Metabolomics Australia, Murdoch University.

Presentations:

Part of this work has been presented at a scientific conference in poster format;

Fee, E.L., Gummer, J.P.A, Trengove, R.D., Hartmann, P.E., Geddes, D.T., Lai, C.T. and Trengove, N.J. 2014. Sodium and potassium concentration in human milk samples of mothers experiencing nipple pain. Combined Biological Science Meeting, 29th August 2015.

Tables of Contents

Towards the Identification of Metabolite Markers of Nipple Pain and Inflammation in Human Milk	i
Acknowledgements.....	ii
Preface.....	v
Tables of Contents	vii
List of Figures.....	ix
List of Tables	xi
List of Units	xiii
Abbreviations	xiv
Abstract.....	xvii
1 Literature Review	1
1.1 <i>Introduction</i>	1
1.1.1 Benefits of breastfeeding for mother and infant.....	1
1.1.2 Breastfeeding incidence and duration in Australia	4
1.2 <i>Anatomy of the lactating breast</i>	6
1.2.1 Macroscopic anatomy	7
1.2.2 Microscopic anatomy	9
1.3 <i>Physiology of lactation</i>	10
1.3.1 Secretory differentiation	10
1.3.2 Secretory activation.....	11
1.4 <i>Secretory pathways</i>	12
1.4.1 Transcellular pathways.....	12
1.4.2 Paracellular pathway	13
1.5 <i>Pathology of the human breast</i>	13
1.5.1 Nipple pain	15
1.5.2 Mastitis.....	16
1.5.3 Breast thrush	18
1.6 <i>Composition of human milk</i>	19
1.6.1 Macronutrients and micronutrients.....	21
1.7 <i>New methods of milk analysis</i>	23
1.7.1 Metabolomics	24
1.7.2 Gas chromatography mass spectrometry (GC-MS).....	25
1.7.3 Untargeted metabolomics.....	27
1.7.4 Targeted metabolomics	28
1.7.5 Summary	28
1.8 <i>Aims and Hypothesis</i>	29
1.8.1 Project outline.....	29
1.8.2 Hypothesis	29
1.8.3 Aims	29
2 Materials and Methods	31
2.1 <i>Materials</i>	31
2.2 <i>Methods</i>	39
2.2.1 Human sample collection	39
2.2.1.1 Recruitment	39
2.2.1.2 Human milk collection	40
2.2.1.3 Participant demographic data analysis.....	41
2.2.2 Bovine sample collection.....	42

2.2.3	Microbial methods	43
2.2.3.1	Media preparation.....	43
2.2.3.2	Culture.....	43
2.2.3.3	Bacterial and fungal species detection through Gram stain	44
2.2.3.4	<i>S. aureus</i> identification.....	45
2.2.3.4.1	Latex agglutination test.....	45
2.2.3.4.2	DNase agar plate.....	45
2.2.3.5	Data analysis.....	46
2.2.4	Sodium and potassium analysis	46
2.2.4.1	Preparation of concentration standards	47
2.2.4.2	Preparation of calibration recovery standards	48
2.2.4.3	Method optimisation: recovery assay for calibration recovery standards	49
2.2.4.4	Measurement of Na ⁺ and K ⁺ ion concentration in milk.....	52
2.2.4.5	Data analysis.....	54
2.2.5	Metabolomic profiling of human and bovine milk	55
2.2.5.1	Metabolite analyses	55
2.2.5.1.1	Milk volume optimisation for derivatisation	57
2.2.5.1.2	Derivatisation temperature optimisation	58
2.2.5.2	Preparation of the final sample set (using the optimised methodology).....	59
2.2.5.3	Instrumentation and data acquisition.....	60
2.2.5.4	Data analysis.....	61
2.2.5.5	Data processing and interpretation.....	61
3	Results.....	62
3.1	<i>Human study population.....</i>	62
3.1.1	Sample demographics.....	63
3.1.2	Pain assessment	64
3.1.3	Medication	65
3.2	<i>Bovine study population.....</i>	67
3.3	<i>Microbe assessment results.....</i>	68
3.3.1	Quantification of microorganisms.....	70
3.3.2	Identification of microorganisms	73
3.3.2.1	5% Horse blood agar.....	73
3.3.2.2	Mannitol salt agar.....	76
3.3.2.3	Vogel-Johnson agar.....	77
3.3.2.4	<i>S. aureus</i> specific DNase agar plate.....	79
3.3.2.5	Latex agglutination test	80
3.3.3	Fungal species identification	81
3.3.3.1	Sabouraud Agar.....	81
3.3.3.2	Yeast Extract Glucose Chloramphenicol (YGC) agar and Dichloran Rose Bengal Chlortetracycline (DRBC) agar.....	82
3.3.4	Microbial diversity	83
3.4	<i>Sodium and potassium ion analysis</i>	84
3.4.1	Measurement of sodium and potassium in human and bovine milk samples 84	
3.5	<i>Metabolomics methods optimisation.....</i>	90
3.5.1	Sample volume optimisation	90
3.5.2	Temperature optimisation	94
3.6	<i>Changes to the metabolite composition of human milk in response to pain and trauma of the nipple</i>	98
4	Discussion	111
5	Conclusion	129
	References	131
	Appendices	146

List of Figures

1.1	Prevalence of breastfeeding in Australia in 2001.....	5
1.2	Macroscopic anatomy of the normal lactating mammary gland.....	8
1.3	A simplified model of a gas chromatographer mass spectrometer.....	26
2.1	Na ⁺ standard curve and logarithmic equation.....	50
2.2	K ⁺ standard curve and logarithmic equation.....	50
2.3	Reproducibility calculations for calibration recovery standards.....	51
2.4	Comparison of Na ⁺ standard curves.....	53
2.5	Comparison of K ⁺ standard curves.	53
3.1	Sample collection area.....	62
3.2	Log of the CFU/ml in human whole milk cultured on blood agar.....	71
3.3	Blood agar cultures of human milk, control and nipple pain.....	74
3.4	Blood agar culture and Gram stain of a bovine vat sample (BV02).....	75
3.5	Blood agar culture and Gram stain of a bovine vat sample (BV01).....	75
3.6	MSA culture and Gram stain of human milk sample from a mother (M18) with persistent nipple pain (PG).....	76
3.7	Vogel Johnson cultures of human and bovine milk samples.	78
3.8	DNase agar plate used for the identification of <i>S. aureus</i>	79
3.9	The Latex agglutination test for the detection of <i>S. aureus</i>	80
3.10	Sabouraud agar culture and Gram stain of a bovine milk sample.....	81
3.11	YGC and DRBC agar cultures of a single pooled bovine vat sample (BV01).....	82
3.12	Box plots of Na ⁺ and K ⁺ concentration and Na ⁺ /K ⁺ ratio.....	87
3.13	Box plots of Na ⁺ and K ⁺ concentration and Na ⁺ /K ⁺ ratio for human milk samples, with bovine values.....	89

3.14	Peak area of L-Phenylalanine (1 TMS) vs. test temperatures.....	96
3.15	Standard deviation of L-Phenylalanine (1 TMS) vs. test temperatures.....	96
3.16	Peak area of L-Methionine (1 TMS) vs. test temperatures.....	97
3.17	Standard deviation of L-Methionine (1 TMS) vs. test temperatures.	97
3.18	Final metabolomic GCMS sequence run order.....	101
3.19	Scores plot of PC-1 (25%) vs. PC-2 (14%) for the final sample set.....	103
3.20	Score plot of PC-3 (10%) vs. PC-4 (8%) for human milk samples.....	105
3.21	Loadings plot of PC-3 (10%) vs. PC-4 (8%) for human milk metabolites....	106
3.22	Correlation loadings plot of PC-3 (10%) vs. PC-4 (8%) for human milk metabolites.....	108

List of Tables

1.1	Excess costs and deaths at current breastfeeding rates compared with projected costs.....	2
1.2	Human milk composition between 1 and 28 days post partum.....	20
1.3	Summary of macronutrient composition from past studies.....	21
1.4	Changes in milk components in early lactation.....	22
2.1	Human milk collection method, with supplier listed.....	32
2.2	Bacteriology methods, with supplier and abbreviations listed.....	33
2.3	Sodium and potassium analysis, with supplier and abbreviations listed.....	34
2.4	Metabolomic analysis of human and bovine milk, with supplier and abbreviations listed.....	35
2.5	List of metabolite reference standards used for metabolomic method optimisation, with supplier listed.....	36
2.6	Equipment used, with manufacturer listed.....	37
2.7	Data analysis software, with manufacturer listed.....	38
2.8.	Preparation of sodium and potassium standards, used to determine a standard curve.....	48
2.9	Preparation of calibration recovery standards.....	48
2.10	Reproducibility of calibration recovery standards.....	52
3.1	Characteristics of infants and mothers of control group and nipple pain subgroups.....	66
3.2	Distribution of bovine milk samples.....	67
3.3	Number of microorganisms in human and bovine whole milk samples from blood agar cultures.....	72

3.4	Distribution of bacterial and fungal species between groups.....	83
3.5	Summary of Na ⁺ and K ⁺ concentration and Na ⁺ /K ⁺ ratio recorded for human milk samples.....	86
3.6	Summary of Na ⁺ and K ⁺ concentration and Na ⁺ /K ⁺ ratio recorded for bovine milk samples.....	88
3.7	%RSD of ¹³ C ₆ Sorbitol and Alkanes.	93
3.8	Correlation loadings plot metabolite IDs, and axis coordinates, associated with nipple pain and control sample groups.....	110

List of Units

Abbreviation	Meaning
L	Litre
ml	Millilitre
μ l	Microliter
g	Gram
mg	Milligram
μ g	Microgram
ng	Nanograms
$^{\circ}$ C	Degree/s celsius
rpm	Revolutions per minute
mM	Millimolar
mmol	Millimole
N	Normal (molarity)
eV	Electron volt
m	Metres
mm	Millimetres
μ m	Micrometres
min	Minutes
hr	Hour
amu	Atomic mass units
g	Gravity (centrifuge)

Abbreviations

Abbreviation	Meaning
ABA	Australian Breastfeeding Association
ACN	Acetonitrile
B01-04	Bovine 01-04
BC	Bovine control group
BM	Bovine mastitis group
BV	Bovine vat sample group
C01-22	Human control samples 01-22
CG	Control group (human)
CI	Confidence interval
CLED	Cysteine Lactose Deficient agar
CFU	Colony forming unit
CNS	Coagulase negative staphylococci
CV	Crystal violet
DDI	Distilled deionised water
DECL	Decolourizer solution
DNase	Deoxyribonuclease
DRBC	Dichloran Rose Bengal Chlortetracycline
EI	Electron ionisation
FDA	Food and Drugs Administration
GC	Gas chromatography
GC-MS	Gas chromatography mass spectrometry
GI	Gram's iodide

HHLRG	Hartmann Human Lactation Research Group
HMO	Human milk oligosaccharide
K ⁺	Potassium ion
KCl	Potassiumchloride
LC-MS	Liquid chromatography mass spectrometry
MS	Mass spectrometry
MSA	Mannitol Salt agar
MSTFA	N-Methyl-N-(trimethylsilyl)trifluoroacetamide
m/z	Mass to charge ratio
Na ⁺	Sodium ion
NaCl	Sodium chloride
NHMRC	National Health and Medical Research Council
NIST	National Institute of Standards and Technology
NMR	Nuclear magnetic resonance spectroscopy
NP	Nipple pain
NP01-11	Human nipple pain samples 01-11
OR	Odds ratio
PCA	Principal component analysis
PCR	Polymerase chain reaction
PG	Pain group (without evidence of trauma) (human)
QC	Quality control
RSD	Relative standard deviation
SF	Safranin aqueous stain
SIDS	Sudden infant death syndrome
SIM	Selected Ion monitoring

SPE	Solid phase extraction
TG	Trauma group (human)
TM	Thermomix
TMS	trimethylsyl
V01-02	Bovine vat (pooled) samples 01-02
VAS	Visual analog scale
YGC	Yeast Extract Glucose Chloramphenicol

Abstract

Background

Human milk is considered the best source of nutrition for all newborns as it contains important growth, developmental and immunological factors. The WHO (2003) recommends exclusive breastfeeding for the first six months of age, with complementary breastfeeding up to two years and beyond. However, some women experience complications of the breast that lead to early cessation of breastfeeding, which can adversely affect the well being of the developing infant and her own health.

Nipple pain is the most commonly cited reason for weaning in the first week post partum. Nipple pain is also linked to mastitis from milk stasis and possible bacterial infection, although the influence of bacteria is still largely unknown. However, it is known that the presence of bacteria and fungi along with their metabolites contribute to the composition of the milk as the baby receives it.

Metabolomics is increasingly being utilised in the dairy industry to determine spoilage as a result of teat trauma and mastitis. Given the current diagnostic application of metabolomics in clinical medicine uses blood and urine samples, it has been proposed as a potential tool for detecting biomarkers and determining compositional changes in human milk. Measuring the composition of milk from human mothers experiencing persistent nipple pain, with or without evidence of trauma, and identifying the influence of this condition on endogenous and exogenous metabolites may determine the relationship between milk composition and nipple pain.

Aims

The aims of this study were to source the appropriate human and bovine milk samples; to identify and quantify bacterial and fungal species using traditional culture and microscopy techniques; to measure the effect of nipple pain on the paracellular pathway of the breast by measuring the sodium and potassium concentration and ratio in the milk; to optimise GC-MS methodology for the measurement of milk metabolites; and to use untargeted metabolomics to identify compositional differences

in the metabolite profile in human milk from mothers presenting with nipple pain compared to healthy control mothers.

Results

Two groups were recruited; a control group of mothers not experiencing nipple pain (n=22 samples) and a group of mothers experiencing persistent nipple pain during breastfeeding (n=11 samples); mothers with unilateral nipple pain supplied a milk sample from their affected and non-affected breast (n=4). The nipple pain group (n=11) was divided into two subgroups; persistent nipple pain without evidence of trauma (PG) (n=6) and persistent nipple pain with evidence of trauma (TG) (n=5). Additionally 9 bovine samples were collected, 3 from healthy cows (control), 4 from cows presenting with mastitis and 2 from a single storage vat, to be used as positive controls throughout the study.

All 42 samples were tested for the presence of microbial and fungal species, sodium and potassium concentrations and ratio were determined and untargeted metabolomics analysis of the milk metabolome was performed.

Overall there was no significant difference in microbe content between the human control and nipple pain group (1, 623 CFU/ml vs. 1, 503 CFU/ml); the TG subgroup had the highest colony count of 2, 778 CFU/ml. The bovine mastitis group had a higher colony count than the bovine control group, 2, 173 CFU/ml vs. 473 CFU/ml. Coagulase negative staphylococcus ssp. were the most frequently isolated microorganisms and was found in 91% of human milk samples and 100% of bovine milk samples. *Staphylococcus aureus* were identified in one human milk sample from a mother in the PG subgroup and in one bovine sample from a cow suffering from untreated mastitis as well as both pooled bovine vat samples. *Streptococcus* ssp. and yeast were only found in bovine samples.

The TG subgroup had the highest Na⁺ concentration of the human milk samples (8.04 ± 2.40 mM), significantly higher than the control group (4.32 ± 1.18 mM; p<0.001). There was no significant difference in Na⁺ concentration between the TG and PG subgroups. The Na⁺/K⁺ ratio was significantly higher in the TG subgroup (0.55 ± 0.14) compared to the control group (0.34 ± 0.09) (p<0.001); there was no significant

difference in ratio between the PG and TG subgroups ($p=0.10$). No sample recorded a Na^+/K^+ ratio above 1, consistent with the physiological observations and indicative of no mother presenting with mastitis.

Untargeted metabolomic analysis found compositional differences between the human control and nipple pain groups, in particular samples from the TG subgroup. Compositional variations between milk from the control and nipple pain subgroups was identified using principal component analysis and PC4 best represented the differences in metabolite composition between the groups. This result is consistent with the subtlety of the nipple pain condition. A list of the most influential metabolites based on their correlation loadings (explained within 50-100% of the model) was determined. The most influential metabolites with respect to the TG milk samples were included isoleucine, proline, galactose and some as yet unidentified metabolites.

Conclusion

As nipple pain is often a precursor to mastitis the results from this study will form a basis for further development using metabolomics as a tool for more efficient detection and treatment of breast infection and inflammation within the nipple and breast.

1 Literature Review

1.1 Introduction

1.1.1 Benefits of breastfeeding for mother and infant

Human milk is considered the ‘gold standard’ nutrition for infants as it provides optimal nutrition, promotes normal growth and development and reduces the risk of developing illness or disease (Heikkila & Saris, 2003). The WHO (2003) recommends exclusive breastfeeding for the first six months of age, with complementary breastfeeding up to two years and beyond. In Australia the National Health and Medical Research Council (NHMRC) Guidelines recommend exclusive breastfeeding for the first six months of age and the continuation of breastfeeding for up to at least one year (NHMRC, 2012). Where breastfeeding is not possible human donor milk is the preferred substitution ahead of infant formula (Hartmann, Pang, Keil, Hartmann & Simmer, 2007).

Breast milk is readily available, financially affordable and an environmentally sustainable source of sustenance for developing infants and contributes to numerous positive health outcomes for both the mother and infant. An American based study by Bartick and Reinhold (2010) found that if 90% of US families could comply with the medical recommendation to breastfeed exclusively for 6 months that the United States would save almost \$13 billion a year and prevent an excess of 911 deaths annually, nearly all of whom would be infants (95%) (Table 1.1).

Table 1.1 Excess costs and deaths at current breastfeeding rates compared with projected costs if 90% or 80% of US parents complied with the medical recommendation to exclusively breastfeed for 6 months.

	Excess Costs Compared with 90% Compliance (Excess Deaths), 2007 \$US	Excess Costs Compared with 80% Compliance (Excess Deaths), 2007 \$US
Total	12 974 676 651 (911)	10 491 841 489 (741)
SIDS	4 725 328 464 (447)	3 722 074 013 (352)
NEC deaths	2 631 165 267 (249)	2 218 109 495 (210)
LRTI deaths	1 820 102 146 (172)	1 537 915 767 (146)
Otitis media	908 793 396	765 766 295
Atopic dermatitis	601 358 918	497 497 274
Childhood Obesity	592 100 121	404 195 504
LTRI hospitalisation	451 592 572	381 578 219
Childhood asthma	335 796 234	229 194 255
NEC	266 536 884	219 843 084
Childhood asthma deaths	216 869 872 (21)	148 022 294 (14)
Gastroenteritis	186 016 678	162 076 307
Childhood leukaemia deaths	133 422 239 (13)	133 422 239 (13)
Childhood T1D deaths	95 231 472 (9)	64 999 258 (6)
T1D	8 376 168	5 717 067
Childhood leukaemia	1 986 220	1 430 416

This table was reproduced from Bartick & Reinhold (2010)

LRTI- Lower respiratory track infection

NEC- Necrotizing enterocolitis

T1D- Type 1 diabetes

Breastfeeding has been linked to many immediate and lifelong benefits for the developing infant. Research has shown that an exclusively breastfed infant between the ages of 1-6 months consumes an average of 750-800ml over a 24 hour period (range 500-100 ml) (ABS, 2015). A study of nine year old children by McCrory and Layte (2012) found that children who were breastfed (>13 weeks) had a 38% reduced

risk of obesity and those who were breastfed for 26 weeks and beyond had a 51% risk reduction for obesity. Additional studies have found a dose-response effect on cognitive and neural development, where the duration of breastfeeding correlated positively with an increase in IQ (Michaelsen, Lauritzen, Mortensen & Jorgensen, 2003).

Functional nutrients such as human milk oligosaccharide (HMO) in human milk provide the microenvironment for gut protection and maturation (Newburg, 2005). Due to the immature nature of the infants gut at birth they are more susceptible to intestinal and systemic infections. The ingestion of breast milk, in particular colostrum, results in differentiation of immature to mature epithelia (with subclasses of enterocytes and lymphoid tissue) and active maturation of the infants own mucosal immune system for protection against infection and immune mediated disease (Walker, 2010).

Furthermore, research has found that breastfed infants are less susceptible to a range of serious illnesses and conditions such gastroenteritis, respiratory illness and otitis media (AIHW, 2009). Conversely, exclusive formula feeding presents numerous health risks to the developing infant including increased risk of allergies including eczema and atopic dermatitis, and (potential) ingestion of contaminants (Tait, 2000).

Breastfeeding has been found to provide many maternal benefits and research suggests a dose-response effect with breastfeeding and health risk (Godfrey & Lawrence, 2010). A history of lactation has been associated with a reduced risk of cancer including breast and ovarian and decreased incidence of type II diabetes (Ip,

Chung, Ramam, Trikalinos & Lau, 2009). The practice of breastfeeding enhances the mother-child bond and therefore positively correlated with a decrease in post-partum depression and associated with a decreased rate of neglect and abuse (Strathearn, Mamun, Najman & O'Callaghan 2009).

Numerous maternal benefits are associated with breastfeeding such as a decrease in maternal post-partum blood loss, more rapid involution of the uterus and a quicker return to pre-pregnancy body weight than mothers who don't breastfeed (American Academy of Pediatrics, 2012). In mothers with no history of gestational diabetes breastfeeding duration was found to decrease the risk of developing type II diabetes by 4-12% (Schwarz et al., 2010). Furthermore mothers who breastfeed are less likely to develop rheumatoid arthritis (Karlson, Mandl, Hankinson, & Grodstein, 2004), hypertension, hyperlipidaemia and cardiovascular disease including coronary heart disease (Godfrey & Lawrence, 2010).

Given the multitude of short and long term benefits of breastfeeding to the mother and infant, promotion of breastfeeding is of global importance given the increase in incidences of the diseases aforementioned, particularly in developing countries where breastfeeding rates have been falling.

1.1.2 Breastfeeding incidence and duration in Australia

In Australia and internationally breastfeeding has received increased attention as a means for improving public health, contributing to health, nutrition and wellbeing of infants and mothers. Benefits of breastfeeding are largely dose-dependent, therefore extending duration is highly desirable in terms of facilitating infant growth and

development and ensuring maximal maternal benefit. A national survey in 2001 found 87 % of infants aged up to three years of age had obtained nutrition from breast milk at some stage, in the form of exclusive breastfeeding or complementary breastfeeding with the addition of solids or substitutes (ABS, 2003). The incidence of breastfeeding post hospital discharge has increased from 40-45% in the 1970's to 82% and 83% in 1995 and 2001 respectively (ABS, 2003). Despite rising rates in initiation of breastfeeding, duration rates still dramatically decline despite recommended duration of one year by the NHRMC (2010) or up to two years by the WHO (2001).

Rates of duration of breastfeeding between 1995 and 2001 showed that 48% of mothers were still breastfeeding at 6 months, however this decreased to 23% at 1 year and only 1% of mothers were still breastfeeding 2 years after parturition (Figure 1.1) (NHRMC, 2003).

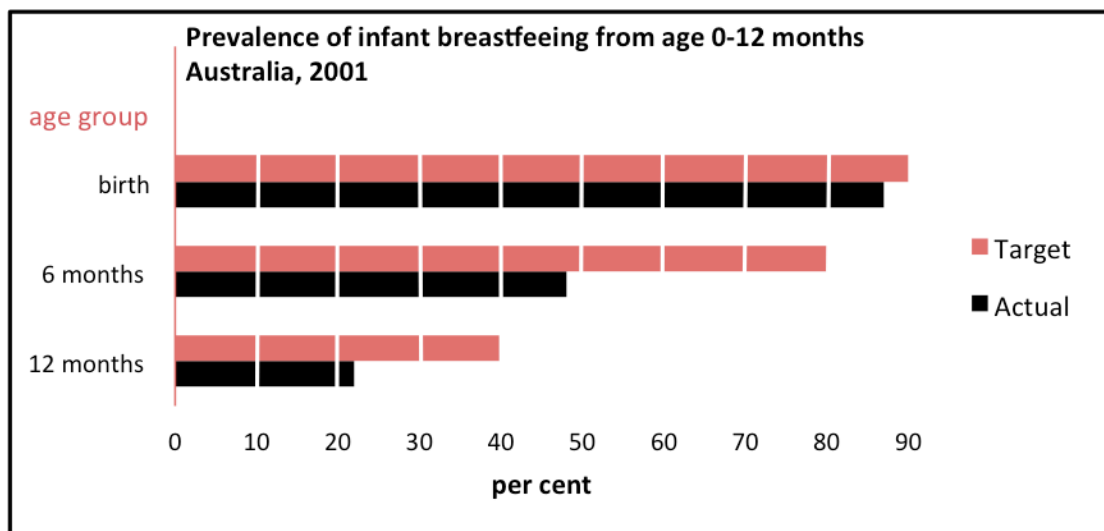

Figure 1.1 Prevalence of breastfeeding in Australia in 2001.
Reproduced from The National Health and Medical Research Council (2003).

More recent research suggests that the incidence and duration of breastfeeding in Perth, Western Australia, has increased significantly, in particular between 1992/3-

2002/3 where prevalence reached national targets for breastfeeding (>90% of mothers were breastfeeding at the time of discharge) (Graham, Scott, Binns & Oddy, 2005). In Perth 93% of mothers were breastfeeding at discharge from the hospital between 2002-2004 (Win, Binns, Zhao, Scott and Oddy, 2006). Additionally, the 2010 Australian National Infant Feeding Survey (NHMRC, 2010) found breastfeeding initiation rates have increase to 90-96% on discharge from hospital, with 50-60% and 22-28% still breastfeeding at 6 and 12 months respectively. Despite these initiation rates being higher than the national average in 2001, previously mentioned as 83%, and approaching those reported for Nordic countries (Lande et al., 2003; Ekstroem, Widstroem & Nissen, 2003), the increase in initiation doesn't appear to be accompanied with an increase in breastfeeding duration (Scott, Binns, Oddy& Graham, 2006). Breastfeeding rates dropped to 45.9 % (of whom 12 % were exclusively breastfeeding) by 6 months post partum and by one year only 19.2 % were reported to be breastfeeding (Scott et al., 2006).

Whilst hospital policy, promotion and support have increased breastfeeding initiation rates, breastfeeding duration has not substantially improved. This is likely due to the need to return to work and difficulties experienced by breastfeeding women such as perceived inadequate milk supply, nipple pain and mastitis which lead to premature weaning (Abou-Dakn, Richardt, Schaefer-Graf & Wockel, 2010).

1.2 Anatomy of the lactating breast

An understanding of the macroscopic and microscopic anatomy of the lactating breast can help us better understand the development of pathologies and their observed effects on the mammary tissue and its' secretions. Breast pathologies, for example

mastitis, can compromise the integrity of the breast, therefore changes in milk composition are considered to be an important indicator of the physiological state of the mammary tissue (McManaman & Neville, 2003). A fundamental knowledge of the anatomy of the breast can aid in diagnosis and treatment development.

1.2.1 Macroscopic anatomy

The human breast is comprised of two main tissues, adipose and glandular (secretory), held loosely together by a network of fibrous connective tissue called coopers ligaments (Ramsay, Kent, Hartmann, R. & Hartmann, P., 2005) (Figure 1.2). It is important to note that there is large variation between women. Not only do the breasts of some women contain more adipose tissue, the amount of adipose tissue situated between glandular tissue is also highly variable (Geddes, 2007). In some cases the amount of glandular tissue was found to exceed adipose tissue by double (Geddes, 2007). A study by Ramsay et al. (2005) found no correlation with milk production or storage capacity and the estimated volume of secretory or glandular tissue (including the number of ducts and the mean diameter of the milk ducts) (Ramsay, et al. 2005).

The glandular tissue contains a secretory system, which is drained by a ductal system that stores and transports milk to the nipple during lactation. Based on the 1840's Cooper's dissections of the lactating breast (Cooper, 1840), it was previously believed that the lactating breast contained 15-20 ducts (however, Cooper identified up to 22 ducts in one instance), with 7-12 generally found to be patent. However, more recent studies using 2D ultrasound (Ramsay et al. 2005) found the glandular tissue of each breast to contain approximately 9 milk ducts (range 4-18) with a mean diameter of 2 ± 0.8 mm (range 1.0-4.4 mm) (Ramsay et al. 2005). Another study by Love and Barsky

(2004), using a combination of in vivo and in vitro techniques, resolved that 90 % of nipples contained 5–9 milk ducts (with a nipple orifice), arranged in a central and peripheral orientation.

Furthermore Cooper (1840) described the proximal ducts to be large sac like structures that converged into one main milk duct, known as a lactiferous sinus. However, recent studies using 2D ultrasound imaging (Ramsay al. 2005) and 3D ultrasound imaging (Gooding, Finlay, Shipley, Duck & Halliwell, 2010) found an absence of lactiferous sinuses and rather the main milk ducts to be relatively small with expanding areas coinciding with merging ducts. Furthermore the ducts have been found to dilate during milk ejection in order to transport milk towards the nipple for the suckling infant (Ramsay et al. 2005).

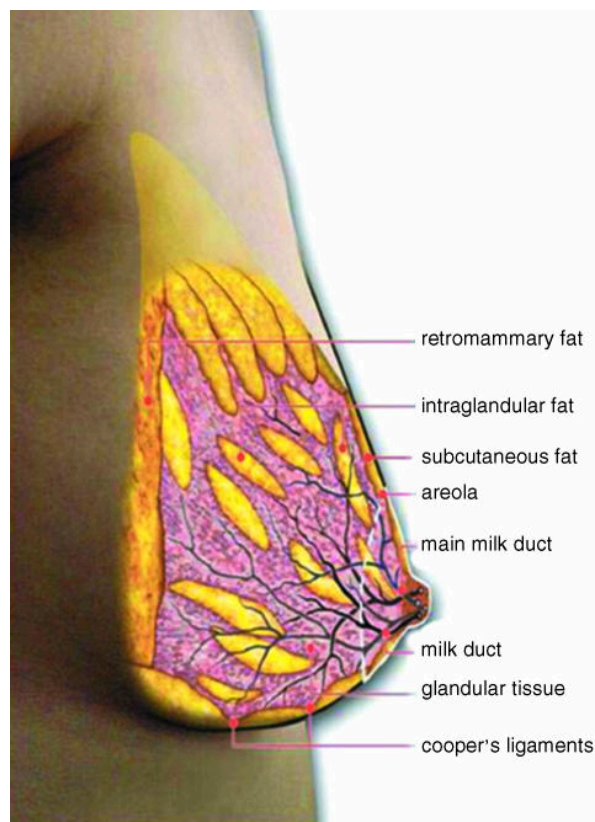

Figure 1.2 Macroscopic anatomy of the normal lactating mammary gland.
Reproduced from Ramsay et al. (2005).

1.2.2 Microscopic anatomy

The mammary gland is comprised of lactocytes, ductal epithelial cells, myoepithelial cells and mammary stem cells (Berry, 2009). The lactocytes, secretory epithelial cells, line the alveoli of the breast and are responsible for producing and secreting milk into the luminal space of the alveoli (Berry, 2009). Lactocytes are cuboidal/columnar in shape and link with several specialised junctions, for example tight junctions, which prevent the passage of substances external to the alveolus during established lactation (Linzell & Peaker, 1971). The alveoli are surrounded by myoepithelial cells and a vascular connective tissue stroma that contains adipocytes and fibroblasts (McManaman & Neville, 2003). Myoepithelial cells function during milk ejection when suckling stimulus causes the release of oxytocin into the maternal circulation. Oxytocin binds to myoepithelial cells and causes them to contract (neuroendocrine reflex) thereby ejecting milk from the alveoli into the ducts towards the nipple to be removed by the infant or a breast pump (McManaman & Neville, 2003).

The cytoplasm of lactating alveolar cells is dense in mitochondria and there is an extensive rough endoplasmic reticulum network, as would be expected in a highly active secretory cell (McManaman & Neville, 2003). Additionally the cells contain a Golgi apparatus and secretory vesicles containing casein micelles located in the apical region of the cell (McManaman & Neville, 2003). The alveolar epithelial cells are connected through an apical junctional complex and the epithelial cells on the basal side of the alveolar contact the myoepithelial cells and basement membrane. This forms a separation between the epithelial cells and the stroma and vascular system, creating a barrier for the transfer of substances from blood or stromal cells to the milk.

1.3 Physiology of lactation

The prepubescent breast consists of a basic network of immature ducts, formed by epithelial cells, submerged in the mammary fat pad (Thomas, Williams and Hartmann, 2010). At puberty an increase in ovarian hormones stimulates the ducts to branch out and extend from the nipple and pervade the surrounding fat pad creating a complex ductal network (Thomas et al., 2010). However, the human breast does not reach maximal growth and functional development until pregnancy and parturition (Hale & Hartmann, 2007). The ability to secrete milk develops during pregnancy and is regulated by changes in multiple hormones.

Lactation is defined as the stage of sustained milk production (Pang & Hartmann, 2007). The initiation of lactation occurs in two stages, secretory differentiation and secretory activation (Pang & Hartmann, 2007). Secretory differentiation describes the stage of pregnancy where buds on the end of each duct proliferate and then differentiate to form alveoli lined with functional lactocytes capable of milk synthesis (Hale and Hartmann, 2007). Secretory activation describes the onset of copious milk secretion in association with changes in milk composition as a result of progesterone decline and increase in prolactin secretion at parturition (Pang & Hartmann, 2007). It is essential that secretory activation closely precede parturition to ensure the newborn has a continuous source of nourishment.

1.3.1 Secretory differentiation

Secretory differentiation usually occurs in the later stages of pregnancy at around 24 weeks gestation and is characterised by rapid growth of both the ductal and alveolar structures accompanied by accumulation of the first secretion (colostrum) within the

alveoli and ducts (Hassiotou & Geddes, 2013). Secretory mammary epithelial cells differentiate into lactocytes, functional mammary epithelial cells, with the ability to synthesize unique milk metabolites such as lactose, casein, alpha-lactalbumin and fatty acids (Pang & Hartmann, 2007). Milk synthesis describes the anabolic process leading to the accumulation of milk components in the lactocytes (Pang & Hartmann, 2007).

Alveolar development occurs during the early stages of pregnancy and can be described as the proliferative activity that leads to the development of the mature milk secreting unit (Pang & Hartmann, 2007). Reproductive hormones; oestrogen, progesterone and prolactin together with metabolic hormone's growth hormone, glucocorticoids and insulin must be present for secretory differentiation to occur (Pang & Hartmann, 2007).

1.3.2 Secretory activation

Secretory activation occurs shortly after parturition in women, and it is defined as the onset of copious milk production and marks the commencement of milk secretion (Jensen, 1995). Clinical signs of secretory activation are an abrupt sensation of breast engorgement occurring between 24-72 hours post parturition (Arthur, Smith & Hartmann, 1989). Progesterone withdrawal at parturition, due to the expulsion of the placenta, initiates secretory activation, however the hormones prolactin, insulin and cortisol must also be present (Pang & Hartmann, 2007). Blood prolactin levels are high during early lactation, shown to stimulate milk synthesis and proliferation (Neville et al., 2002). This results in accumulation of milk in the alveoli followed by copious milk secretion.

Post parturition the basement membrane (separating the mammary stroma from the epithelium) experiences a change in integrity characterised by tightening and reduced permeability, resulting in the control of systemic and stromal signalling to the mammary epithelium (Hassiotou & Geddes, 2013). This serves to control the movement of milk components or their precursors via paracellular pathways between the systemic circulation lactocytes and alveolar lumen or the lactocytes (Hassiotou & Geddes, 2013).

1.4 Secretory pathways

Secretory alveoli are enclosed by a basement membrane separating them from the surrounding stroma (Thomas et al., 2010). The basement membrane is important in regulating the activity of the alveolar cells and the components that can pass from the mother's bloodstream or interstitial fluid into the milk (Thomas et al., 2010). There are a number of potential barriers that control the transfer of exogenous substances from the blood or stromal cells to the milk. Metabolites both endogenous and exogenous to the mother can enter the milk via means of transcellular and paracellular pathways.

1.4.1 Transcellular pathways

The transcellular pathway allows movement across the lactocytes and is the mode of movement employed by fat globules, ions (e.g. calcium), glucose, protein hormones, immunoglobulins, and water (Pang and Hartmann 2007).

The transcellular pathway can be divided into four general mechanisms of movement. Two exist for the secretion of endogenously generated molecules, aqueous solutes

including proteins and oligosaccharides and nutrients such as lactose, citrate, phosphate and calcium, and two exist for the transport of exogenous molecules, including numerous macromolecules derived from serum and stromal cells and many ions and small metabolites (McManaman & Neville, 2003).

1.4.2 Paracellular pathway

The paracellular pathway allows direct, bi-directional and extracellular movement of low molecular weight substances and macromolecular solutes from the serum or interstitial space into the milk (McManaman & Neville, 2003). The paracellular pathway becomes closed during lactation as a result of tight junctions between epithelial cells, at which point transcellular pathways act as the only route for transfer of solutes to milk (McManaman & Neville, 2003). The transport of metabolites through this pathway is largely affected by the functional capacity of the mammary gland and can be a direct indication of the physiological state of the lactating breast. Inflammation resulting from mastitis can cause the paracellular pathway to reopen, allowing small molecules including sodium, chloride and glucose to pass freely into the milk space, while molecules such as lactose, potassium and calcium pass from the milk space into the plasma (Jensen, 1995).

1.5 Pathology of the human breast

Breastfeeding is the preferred source of nutrition for all newborns however it is not always an option for all women, as some women experience physiological, psychological or clinical difficulties that prevent them breastfeeding either temporarily or for an extend period of time. A West Australian study of 306

breastfeeding women by Fetherston (1997) found that mastitis is the third most common reason for weaning, with one in four women citing mastitis as their reason for ceasing breastfeeding (Michie, Lockie & Lynn, 2003). More recently a study by Abou-Dakn et al. (2010) found that the most common reason for premature cessation of breastfeeding in early lactation, affecting up to 50% of mothers, is nipple pain and mastitis. In weeks 1-3 insufficient milk supply (37.3%), commonly due to mastitis (Abou-Dakn et al., 2010), followed by breast pain or mastitis (32.9%) was the most common reasons for cessation of breastfeeding (Schwartz, 2002). Women who reported pain in the first three weeks of breastfeeding were more likely to cease breastfeeding than mothers who reported pain beyond three weeks (Schwartz et al., 2002).

The study by Schwartz et al. (2002) also found that women who developed mastitis in the first three weeks post partum were nearly six times more likely to cease breastfeeding than women not suffering from mastitis. Furthermore with every day of pain in the first three weeks there was an increased risk of 10-25% for termination of breastfeeding (Schwartz et al. 2002). Thus mastitis, pain and days with pain in the first three weeks post partum are important clinical factors associated with breastfeeding termination in mothers who prenatally identified themselves as mothers who intended to breastfeed (Schwartz et al., 2002).

Mastitis or, inflammation of the mammary tissue, is a debilitating disease that largely contributes significantly to weaning in the first three weeks post partum. Factors associated with mastitis include pain and discomfort when breastfeeding, ineffective

milk removal, reduced milk flow and the inability to provide sufficient nutrition for the growing infant (Foxman, D'Arcy, Gillespsie, Bobo & Schwartz, 2002).

1.5.1 Nipple pain

Nipple pain, with or without trauma, is a complication associated with breastfeeding found to have a significant impact on breastfeeding in the first few weeks post partum. The incidence is reported to range from 34% up to 96%, with the highest prevalence on day 3 and decreasing by day 7 (Page, Lockwood & Guest, 2009). Incorrect positioning and attachment has been implicated as the major cause of nipple pain, with speculation that increases in suction pressure applied by the infant may be a cause of pain in some women (McClellan et al., 2008); vasospasm, tongue tie and eczema are less common causes of nipple pain. Nipple infection accounts for a proportion of the cases of nipple pain and is thought to be a consequence of nipple trauma. Determining the cause of nipple pain is often difficult, for example severe pain combined with whitish changes of the nipple is often misdiagnosed as *Candida spp.*, resulting in many breastfeeding women receiving incorrect treatment (Holmen & Bache, 2009). The involvement of bacteria in nipple pain is still largely unknown, however a study by Eglash, Plane & Mundt (2006) stated that women with nipple pain without symptoms of acute mastitis were 3 times more likely to culture pathogenic bacteria, most commonly *Staphylococcus aureus*, than candidiasis.

Most lactation consultants agree that nipple soreness in the first week post partum is quite normal, however nipple pain that exceeds the first week is normally a sign of a greater problem that requires skilled assessment and observation (Tait, 2000).

Associated with both frictional and suction lesions, pain can range from an

uncomfortable feeling to severe pain possibly preventing the continuation of breastfeeding (Page et al., 2009). As a result, as many as one third of mothers who experience these complications may change to alternate methods of infant nutrition in the first six weeks after birth (Page et al., 2009).

1.5.2 Mastitis

Mastitis and breast abscess occurs in all populations and at any stage of lactation. WHO (2000) reported the incidence of mastitis to affect ~20% of all lactating women, with 74-95% of cases occurring in early lactation (first 12 weeks after birth). Mastitis can be defined as cellulitis of the interlobular connective tissue within the mammary gland of the breast (Foxman et al., 2002). Clinical symptoms range from focal inflammation with minimal systemic symptoms to abscess and septicaemia in more severe cases (Foxman et al., 2002). Systemic symptoms such as pyrexia and flu like symptoms are often sudden in their onset and vary in severity, with women reporting duration of symptoms ranging from one to 12 days (Fetherston, 2001). The affected breast may appear red, hot and swollen. Factors associated with mastitis also include pain, discomfort when breast feeding and poor drainage (reduced milk removal) which may cause some women to cease breastfeeding (Foxman et al., 2002).

Past research has determined that mastitis is most frequently the result of stasis of milk, without significant deviation in 'normal/healthy' bacterial counts and species. On occasions where milk stasis is not the cause of mastitis, milk infection is often the cause of bacterial colonisation of the breast and can be detected through increased colony counts and predominance of a small number of bacterial clones (Michie et al., 2003). Consequently, mastitis is frequently defined as infectious or non-infectious. The most common type of mastitis is non-infectious mastitis, where inflammation of

the breast tissue results from milk stasis, blocked ducts, engorgement or physical injury (Crepinsek, Crowe, Michener & Smart, 2012).

Infectious mastitis may result from trauma to the skin of the nipple, damaging the integrity of the breast and consequently providing a route for microbial infection (Crepinsek et al., 2012). The most common portal of entry for bacterial infection in women with mastitis is assumed to be through nipple pores into lactiferous ducts (Fetherston, 2001). Infectious mastitis is most often associated with *Staphylococcus aureus*, an organism that can cause an abscess to develop if left untreated (Amir, Forster, McLachlan & Lumley, 2004). A study by Delgado et al. (2009) found that *Staphylococcus epidermidis* was the most prevalent staphylococcus species isolated from mastitic milk and was prevalent in concentrations significantly higher than that normally present in the healthy mother. *S. epidermidis* has been increasingly recognised as an opportunistic pathogen and as a casual pathogen of mastitis, despite being a normal inhabitant of healthy human skin and mucosal microflora (Delgado et al., 2009). *Staphylococci* are known for their pronounced genetic variability and *S. epidermidis* has been found to have mechanisms for adhesion and biofilm formation. Its resistance to certain antibiotics has increased in recent years and it is consequently emerging as a common nosocomial pathogen (Ziebuhr et al., 2006).

Alternatively mastitis can be viewed as a continuum of a disease where the initial non-infectious mastitis develops into a secondary infectious mastitis resulting in the formation of an abscess (Crepinsek et al., 2012). Hence infection, when it occurs, is not primary, but the result of stagnant milk providing a medium for bacterial growth.

Although effective milk removal through feeding, pumping or both is the foundation for all treatment to remove stagnant milk, antibiotics are usually prescribed prophylactically to cover possible bacterial infection (Jahanfar, Ng & Tang, 2013). However, antibiotic prescription is not based on analysis of breast milk, therefore it is not known how many cases are unnecessarily adding to the increase in antibiotic resistant strains of bacteria. To reduce the number of bacteria becoming resistant to antibiotics it is important to correctly diagnose each case of mastitis to reduce their inappropriate use. Thomsen, Hansen & Moller (1983) proposed that levels greater than 10^3 CFU/ml of pathogenic bacteria in breast milk was an indication that antibiotic treatment is required. They concluded that a high bacterial count together with leukocytosis was indicative of infection. Note that the colony forming unit (CFU) count does not take into account the normal bacterial content in milk.

1.5.3 Breast thrush

Some breastfeeding mothers also experience a burning pain in the nipple/breast known as breast thrush, which occurs in 10% of women. Although the exact cause of breast thrush has not yet been confirmed, many researchers believe it is the result of *Candida albicans* infection (Amir et al., 2011). However, due to the presence of other microorganisms it is difficult to identify *C. albicans* as the sole cause. Consequently, it is possible that breast thrush is the result of co-infection caused by the presence of multiple microorganisms such as *S. aureus* or *E. coli* as well as *C. albicans* or other *Candida spp.*

Australian milk banks currently examine the bacteriology of donor milk by culturing all donations on cysteine-lactose-electrolyte deficient (CLED) agar and 5% horse blood agar and quantifying colony growth (Hartmann et al., 2007). Critical limits have been defined for the level of contamination acceptable in raw milk and donations containing a confluent growth of microorganisms exceeding 10^5 CFU/ml are discarded (Hartmann et al., 2007). However, this is not routine practice for the diagnosis of mastitis or causative agents of nipple pain, nor is it conducted before the administration of antibiotics or alternative medications.

1.6 Composition of human milk

Milk is a complex biological matrix made up of thousands of compounds. The complexity of milk reflects the activities of the mammary secretion and transport processes, the physiological condition of the breast and the unique nutritional requirements of the developing newborn (McManaman & Neville, 2003). The constituents in milk provide nutrition, structural components for cellular membranes and non-nutritive functional components e.g. immunological factors (Jensen, 1995).

The composition of human milk is dynamic and highly variable. Variation occurs over the course of lactation, between and within feeds, diurnally, between mothers and with treatment of expressed milk including storage and pasteurisation (Chung, 2014). The mother's nutrition, body mass index (BMI) and parity have also been found to influence milk composition (Hsu et al., 2014). A study by Eilers et al. (2011) found a positive correlation with milk leptin concentration and BMI, suggesting that mothers' adiposity may increase the leptin levels in milk.

Milk composition changes over the course of lactation, which can be divided into the known milk stages colostrum, transitional milk and mature milk. Colostrum marks the first phase of lactation spanning the first 3-5 days after parturition. Colostrum has a distinct biochemical and cellular composition, characterised by high concentrations of protein, fat-soluble vitamins, minerals, and immunoglobulin, designed to provide enhanced immunological protection and nutritional and developmental support to the infant (Hassiotou & Geddes, 2013).

Transitional milk proceeds the colostrum stage lasting up until 2-3 weeks postpartum and has higher levels of fat, lactose and water soluble vitamins and contains more calories than colostrum (Jensen, 1995) (Table 1.2). Thereafter, breast milk is said to have reached the mature phase, the final stage of milk transition, which is maintained for the remainder of lactation (Hassiotou & Geddes, 2013). Mature milk is comprised of 90% water and 10 % carbohydrates, proteins and fats.

Table 1. 2 Human milk composition between 1 and 28 days post partum.

Component	Days post partum						
	1	2	3	4	5	14	28
Yield g/24 hr	50	190	400	625	700	1100	1250
Lactose (g/L)	20	25	31	32	33	35	35
Fat (g/L)	12	15	20	25	24	23	29
Protein (g/L)	32	17	12	11	11	8	9

Recreated from Jensen (1995). Handbook of Milk Composition. The volume of milk, lactose and fat increase and protein decreases as lactation progresses days post partum.

1.6.1 Macronutrients and micronutrients

Milk is a highly complex suspension of lipids, proteins, carbohydrates, secretory immunoglobulins, calcium and various other macro and micro molecules, ions and bioactive factors (Thomas et al., 2010). Table 1.3 is a summary of macronutrient composition of human milk findings from past studies. Fat content (grams per 100ml) can be identified as the most variable nutrient across populations, however individuals within a population showed equal if not greater variations (Prentice, 1995; Wojcik, Rechtman, Lee, Montoya & Medo, 2009).

Table 1.3 Summary of macronutrient composition from past studies.

Population	Fat	Lactose	Protein	Reference
Philippines (Manila)	3.93	7.31	0.85	WHO, 1985
The Gambia	3.78	7.74	1.09	Prentice et al., 1981a
Australia	3.74	6.14	0.92	Mitoulas et al., 2002
Bangladesh	2.66	8.08	1.00	Brown et al., 1986
Sweden	5.69	6.70	0.83	WHO, 1985
Guatemala	2.40	8.00	0.94	WHO, 1985
Zaire	3.30	6.30	1.30	WHO, 1985
USA (DARLING)	3.80	7.40	1.10	Nommsen et al., 1991
Mean	3.66	7.21	1.00	

Reproduced from 'Predictors of breast milk macronutrient composition in Filipino mothers', Quinn, Largado, Power & Kuzawa (2012).

Contents recorded in grams per 100ml and calculated where necessary using a nitrogen to protein conversion factor of 6.38.

The summary of milk macronutrients from past studies found that fat content of human milk varied between 2.4 to 5.69 g/100ml across populations, however women within the same population showed equal if not greater variation than different populations. Carbohydrate and protein content of milk showed less variance, with carbohydrate ranging from 6.14 to 8.08 g/100ml and protein ranged from 0.83 to 1.03 g/100ml.

During the initiation of secretory activation the paracellular pathway closes, preventing movement of small molecules from serum or interstitial space into the milk and vice versa. The closure of tight junctions blocks the paracellular pathway preventing lactose (made by the epithelial cells) from passing from the alveolus to the plasma and sodium and chloride from entering the alveolar lumen from the interstitial space (McManaman & Neville, 2003). This resulted in a fall in sodium and chloride concentration and an increase in lactose concentrations in milk (Table 1.4), which occurs immediately after birth and is complete by 72 hours post delivery (McManaman & Neville, 2003).

Table 1.4 Changes in selected milk components in early lactation.

Component (mmol/L)	Hours post partum				
	21	48	60	96	120
Volume (ml/day)	-	180	350	560	540
Lactose	100	140	160	160	160
Potassium	13.8	15	18	18	18
Sodium	34	25	16	14	14
Chloride	44	35	25	20	20
Calcium	4.0	6.0	6.6	7.6	8

Recreated from Jensen (1995). Handbook of Milk Composition.

The volume of milk and amount of lactose, potassium and calcium increase and sodium and chloride decrease as lactation progresses hours post partum.

Epithelial cells are connected via an apical junctional complex composed of adherens and tight junctional elements that act to prevent direct paracellular exchange of interstitial and milk components (McManaman & Neville, 2003). However, during an episode of mastitis or inflammation the tight epithelial junctions dividing milk and plasma become compromised and the paracellular route reopens, causing plasma components such as sodium and chloride to leak into the milk (McManaman &

Neville, 2003) and components such as lactose and potassium to pass from the milk into the plasma (Jensen, 1995). An elevated milk sodium concentration above the norm (5-6mmol/L) has previously been considered indicative of infection. However, as milk composition varies largely between individuals, it is difficult to determine if sodium concentration levels are an accurate measure of infection or inflammation and consequent damage to the mammary tissue. For this reason, the sodium to potassium ratio has recently been suggested as a possible indication of infection or inflammation as it accounts for individual differences, with a elevated sodium to potassium ratio above 1.0 being considered indicative of mastitis (Aryeetey, Marquis, Timms, Lartey & Brakohipa, 2008).

1.7 New methods of milk analysis

There have been many studies in recent years on bovine mastitis, described as a production disease, as it is the most expensive disease effecting dairy farms world wide, causing enormous financial loss to the dairy industry (Hogeveen, Huijps & Lam, 2011). Metabolomics has been utilized increasingly within the food industry and has been proposed as a useful tool in the dairy industry to ensure proper milk composition and milk of the highest quality (Boudonck, Mitchell, Wulff & Ryals, 2009). Previously diagnosis of mastitis in domesticated animals focused predominantly on quantitative measures, most commonly monitoring milk somatic cell count, which is known to increase during an episode of mastitis (Michie et al., 2003). Estimates of the milk cell count are widely employed to assess milk quality, with lower cell counts attracting higher prices. More recently, a study by Sundekilde et al. (2013) found a series of metabolite biomarkers, including isoleucine, lactate, butyrate and acetate, that were associated with elevated somatic cell count in bovine

milk and suggested that detection of these could be a potential tool to determine milk quality, diagnose mastitis and consequently determine whether milk should be discarded. This knowledge and technology could also be applied to human milk, determining metabolome changes as a means for diagnosis of breast complications particularly mastitis. Furthermore, it can be reasoned that if bacterial and fungal infections are causative agents of nipple trauma and mastitis, their presence and associated endogenous metabolites will contribute to the composition of expressed milk. Consequently, if severity of trauma is correlated to underlying infection, then profiling the metabolome of expressed milk may identify differences in metabolite composition between mothers experiencing varying degrees of pain and discomfort.

1.7.1 Metabolomics

Metabolomics revolves around the central concept that an individual's metabolic state is a close representation of their current physiological state indicating their health or disease status (Fanos, Barberini, Antonucci & Atzori, 2012). Our metabolome is not solely determined by our genes but also influenced by our environment and unique body flora and therefore consists of a mix of endogenous and exogenous metabolites, some of which may include food component or environmental chemicals.

Metabolomics aims to improve understanding of physiology and metabolism by using analytical chemistry techniques to assess metabolic changes in biofluids, tissues and cell extracts to create a metabolic profile (Veselkov et al., 2011).

Metabolomics aims at a quantitative analysis of a large number of low molecular weight metabolites existing as substrates or products in metabolic pathways present in all living systems (Moco, Collino, Rezzi & Martin, 2013). The metabolomics

approach is based on highly sensitive analytical methods with data obtained by quantifying multiple metabolites or small molecules in test samples (Fanos et al., 2012). A typical metabolomic data matrix consists of metabolites and their relative abundances for a sample set including two or more conditions (control and study group/s). The direction of statistical analysis is to identify differences in presence and abundance of metabolites between control and study groups (De Livera et al., 2012). Current techniques commonly used in metabolomic analysis include mass spectrometry coupled with gas chromatography (GC-MS) or liquid chromatography (LC-MS) and nuclear magnetic resonance (NMR) (Fanos et al., 2012).

1.7.2 Gas chromatography mass spectrometry (GC-MS)

GC-MS is a synergistic combination of two techniques, firstly gas chromatography which separates the components of a mixture of molecules and the second, the mass spectrometer which provides structural information of each component measured (Kitson, Larsen & McEwen, 1996). In GC-MS-based metabolomics, complex mixtures of metabolites from a cell, tissue or biofluid are analysed.

Gas chromatography involves volatilization of the sample in a heated inlet, separation of the components of the mixture in a capillary column and detection of each component at the detector (Figure 1.3). A carrier gas (mobile phase) is used to transfer the volatilised sample from injector through the column where separation of each analyte is determined by the partition of each component between the mobile and stationary phase. Only materials that can be volatilised without decomposition are suitable for analysis by gas chromatography.

Within the mass spectrometer analytes are ionised and measured as a function of their mass to charge ratio and represented as a mass spectrum of ions each in relative abundance, which provides a quantitative measure of the abundance of each ionic species as it elutes from the column (Hubschamann, 2008). The measurements are calibrated against ions of known mass to charge ratio and compared to a database of known metabolites to determine presence and abundance of metabolites in a sample (Hubschamann, 2008).

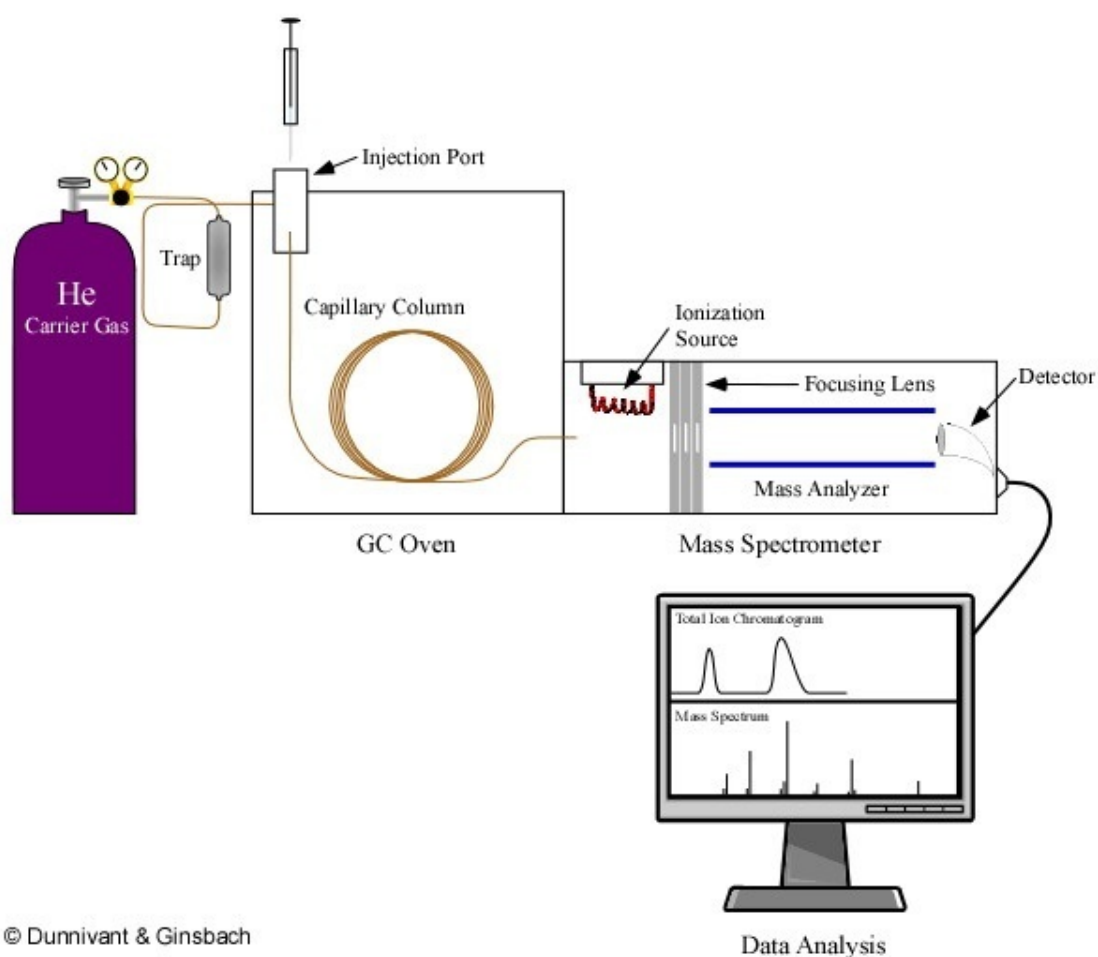

© Dunnivant & Ginsbach

Figure 1.3 A simplified model of a gas chromatograph mass spectrometer. Reproduced from Dunnivant and Ginsbach, 2008.

Interrogation of the GC-MS data requires deconvolution of the chromatogram to distinguish metabolites from non-biological analytes (e.g. artefacts from storage conditions) and to identify these from instrument noise and co-eluting analytes. GC retention times and calculated retention indices together with reproducible and predictable mass fragmentation (for comparison of the features with analysed metabolite standards) are used to identify metabolites by composition, against a library of metabolite mass spectra (Gummer et al., 2012). When used for metabolomics studies, the use of appropriate quality control measures, including internal standards to account for sample extraction and instrumental inter-sample efficiencies and system equilibration, is imperative (Gummer et al., 2012).

1.7.3 Untargeted metabolomics

Metabolomics is a reflection of genetic factors with the expressed metabolites defined as the end point. Mapping a person's metabolome against their phenotype has been proposed as a useful tool for clinical systems biology to detect metabolic changes even before disease symptoms appear (Smolinska, Blanchet, Buydens & Wijmenga, 2012). Blood and urine samples are frequently used to analyse the human metabolome. Milk is an ideal bio-fluid for metabolomics studies since it can be obtained noninvasively, and the composition is directly reflective of genetic and environmental factors affecting breast health, more specifically mammary tissue and the milk secreting cells (lactocytes). With respect to lactation, nipple pain and mastitis have been found to produce biochemical changes in human milk including an increase in sodium and protein concentrations. As a result of cellular changes such as increased neutrophil count and activation of leukocytes causing them to extravasate into the milk at the site of inflammation (Michie et al., 2003; Hassiotou et al., 2013).

1.7.4 Targeted metabolomics

Bacterial and fungal metabolites can be used to detect and quantify bacteria and fungi in a solution. Furthermore metabolites only present in specific species of bacteria could allow more specific detection of target bacteria. GC-MS has successfully been used to identify biomarkers in complex matrixes (e.g. blood and urine) and provides high sensitivity and detection of markers even when present at nanogram levels (Sebastian & Larsson, 2003).

1.7.5 Summary

Research has already begun to identify the milk metabolome, however these studies lack focus on nipple pain and mastitis and their causative agents. There has been no untargeted analysis of metabolites linked to mastitis that may be present in the milk during a mastitis event. Identification of changes to the metabolome in the presence of nipple pain or mastitis, if established, could be a useful tool in clinical diagnosis and determining the underlying problem. Therefore, metabolite profiling has the potential to provide a diagnostic tool for the early identification of inflammatory processes contributing to nipple pain and mastitis. Targeted metabolomics could be used to identify the presence of specific metabolites, such as bacterial metabolites, to determine the influence of bacteria and identify the presence of bacteria as a possible cause of nipple pain and mastitis. This research provides an investigative model for the current work in the human metabolome and provides direction for more specific analysis following the optimisation of untargeted metabolite profiling.

1.8 Aims and Hypothesis

1.8.1 Project outline

This project aims to use current knowledge of human and bovine milk together with traditional microbial and biochemical methods to identify where new generation methods can be useful to gain further knowledge into breast milk composition and the effect of infection and inflammation. Metabolomics using gas chromatography mass spectrometry (GCMS) will allow metabolite profiling of human and bovine milk samples and the identification of possible biomarkers for nipple pain that could potentially develop into mastitis.

1.8.2 Hypothesis

The presence of persistent nipple pain, with and without evidence of trauma, in lactating women will result in changes in human milk metabolite profile due to infection and inflammation compared to asymptomatic women (controls).

1.8.3 Aims

Aim 1: To identify the presence of bacteria and fungi using conventional culture techniques, and to quantify bacteria and fungi detected.

Aim 2: To measure the effects of nipple pain and trauma on the paracellular pathway of the breast by measurement of the sodium and potassium concentration and ratio in human and bovine milk.

Aim 3: To optimise methodology for GC-MS (untargeted) measurement of metabolites in human milk and bovine milk.

Aim 4: To identify differences in the metabolic profile of human milk in mothers with nipple pain (with and without trauma) compared to healthy control mothers (asymptomatic), using untargeted analysis.

2 Materials and Methods

2.1 Materials

All materials used in the methods, are presented in (the following) tables, 2.1-2.5.

Materials are separated into four tables to reflect the four sections presented in the methods. The fifth table contains the identification of metabolite reference standards used for metabolomic optimisation. Materials are presented with supplier and abbreviations where possible and suppliers are arranged in the order they appear in Methods.

Reagents were prepared using double deionized water (DDI) (supplied by The Hartmann Human Lactation Research Group, UWA) unless stated otherwise. DDI water was prepared with a PRELAB Classic water purification system (Ibis Technology, Osborne Park, WA, Australia); the DDI water used for breast sterilisation was further heat sterilised using an autoclave.

Table 2.1 Human milk collection method, with supplier listed.

Chemical

Thermo Fisher Scientific Australia Pty. Ltd.

PDI Alcohol prep pads (70% isopropyl)

Medical and Surgical Requisites Pty Ltd, QLD, Australia

5% Chlorhexidine skin cleanser (Microshield)

Table 2.2 Bacteriology methods, with supplier and abbreviations listed.

Chemical	Abbreviation
<u>Pathwest Laboratory Medicine WA, Forrest House Mt Claremont, WA, Australia</u>	
5% Horse blood agar plates (PO81)	
Deoxyribonuclease (DNase) agar plates (P090)	
Sabouraud Dextrose agar powder (Oxoid- CM0041)	
Vogel-Johnson agar plates (1347)	
Yeast Extract Glucose Chloramphenicol (YGC) agar (1498)	
Dichloran Rose Bengal Chlortetracycline (DRBC) agar plates (1139)	
<u>Sigma-Aldrich Pty. Ltd., Castle Hill, NSW, Australia</u>	
Mannitol Salt Phenol Red agar powder (63567)	
<u>Amber Scientific, Midvale, WA, Australia</u>	
Gram stain kit (ref#-76):	
Crystal violet 0.5% stain (CV-500)	GV
Gram's iodide solution (GI-500)	GI
Decolourizer solution (DECL-500)	DECL
Safarin aqueous stain (SF-500)	SF
<u>Blackaby Diagnostics, Darlington, WA, Australia</u>	
Phadebact latex kit	
<u>Thermo Fisher Scientific Australia Pty Ltd, Melbourne, VIC, Australia</u>	
Hydrochloric acid (1N) (SA48-1)	HCl

Table 2.3 Sodium and potassium analysis, with supplier and abbreviations listed.

Chemical	Abbreviation
<u>Univar®</u> , Redmond, WA, USA	
Sodium chloride (465)	NaCl
Potassium chloride (383)	KCl

Table 2.4 Metabolomic analysis of human and bovine milk, with supplier and abbreviations listed.

Chemical	Abbreviation
<u>Thermo Fisher Scientific Australia Pty. Ltd., Melbourne, VIC, Australia</u>	
Methanol (LCMS grade) (A454-4)	MeOH
Water (LCMS grade) (W6-4)	
Acetonitrile (A955-4)	ACN
Hexane 95% (H306-4)	
<u>Sigma-Aldrich Pty. Ltd., Castle Hill, NSW, Australia</u>	
D-Sorbitol- ¹³ C ₆ 99% (605514)	
N-Methyl-N-(trimethylsilyl) trifluoroacetamide(M7891)(394866)	MSTFA
Methoxyamine hydrochloride 98% (226904)	
2-Aminoanthracene (A38800)	
<u>Ajax Finechem, Sydney, NSW, Australia</u>	
Pyridine (AJA430)	
<u>Chem Service Inc., West Chester, PA, USA</u>	
n-decane C ₁₀ (0-729) (Purity – 99.8%)	
n-dodecane C ₁₂ (0-731) (Purity - 99.4%)	
n-pentadecane C ₁₅ (0-2238) (Purity - 98.9%)	
n-nonadecane C ₁₉ (0-2203) (Purity – 99.4%)	
n-docosane C ₂₂ (0-2089) (Purity – 99.2%)	
n-octacosane C ₂₈ (0-2227) (Purity- 99.5%)	
n-dotriacontane C ₃₂ (0-2095) (Purity - 98.5%)	
n-hexatriacontane C ₃₆ (0-2128) (Purity - 98%)	
<u>Grace Davison Discovery Sciences, Rowville, VIC, Australia</u>	
SPE bulk sorbent prevail C ₁₈ (%125474)	SPE

Table 2.5 List of metabolite reference standards used for metabolomic method optimisation, with supplier listed.

Metabolite

Sigma-Aldrich Pty. Ltd., Castle Hill, NSW, Australia

L-Valine (V0500) (Purity 98%)
L- Alanine (A7627) (Purity 98%)
Glycine (241261) (Purity 99%)
L- Leucine (L8000) (Purity 98%)
L-Proline (P0380) (Purity 99%)
L-Isoleucine (I2752) (Purity 98%)
L-Norleucine (N6877) (Purity 98%)
L-Cysteine (168149) (Purity 98%)
Urea (U5378)
L-Serine (S4500) (Purity 99%)
Ethanolamine (E9508) (Purity 98%)
L-Threonine (T8625) (Purity 98%)
Succinic Acid (398055) (Purity 99%)
Putrescine (dihydrochloride) (P7505) (Purity 98%)
L-Serine (S4500) (Purity 99%)
L-Methionine (M9625) (Purity 98%)
L-Aspartic acid (A9256) (Purity 98%)
L-Glutamic Acid (G1251) (Purity 99%)
L-Phenylalanine (P2126) (Purity 98%)
a-Ketoglutaric acid (K1750) (Purity 98.5%)
Ribitol (Adonitol) (A5502) (Purity 99%)
Citric acid (251275) (Purity 99.5%)
L-Lysine (L5501) (Purity 98%)
D-(-)-Fructose (F0127) (Purity 99%)
L-Tyrosine (W373605) (Purity 97%)
D-Mannitol (M4125) (Purity 98%)
D-Sorbitol (S1876) (Purity 98%)
Myo-inositol (I5125) (Purity 99%)
Ribose-5-phosphate (disodium salt hydrate) (83875) (Purity 99%)
L-Tryptophan (T0254) (Purity 98%)

Table 2.6 Equipment used, with manufacturer listed.

Equipment

Medela AG, Baar, Switzerland

Symphony® breast pump and attachments

Quick Clean™ microwave bags

Corning Incorporated, Corning, NY, USA

PC-351 HOT Plate Stirrer

Getinge AB Group, Getinge, Sweden

HS4406 Steam Sterilizer (autoclave)

Forma Scientific, Inc., Marietta, OH, USA

3164 - Water Jacketed Incubator

Horiba Scientific Ltd., Kyoto, Japan

LAQUAtwin sodium ion electrode (S022)

LAQUAtwin potassium ion electrode (S030)

Crown Scientific Pty Ltd., NSW, Australia

Eppendorf Thermomixer® comfort

Microcentrifuge 5415R

IKA MS1 Works (vortex)

Bruker Daltonics, Billerica, MA, USA

450-GC Oven

Shimadzu Corporation, Kyoto, Japan

GC-MS- Shimadzu QP2010 Ultra, Kyoto, Japan

Table 2.7 Data analysis software, with manufacturer listed.

Software

R Development Core Team

R 3.0.3 GUI 1.638 Snow Leopard build 32-bit (6660)

SpectralWorks Ltd, Cheshire, United Kingdom

AnalyzerPro 2.7.0.0

Shimadzu Corporation, Kyoto, Japan

GCMSsolution 2.61

Camo Software AS

The Unscrambler

SAS Institute Inc.

JMP 8.0.2

2.2 Methods

2.2.1 Human sample collection

2.2.1.1 Recruitment

Mothers between the ages of 18-45 years currently breastfeeding a baby between the age of 1-6 months were recruited. Participants were predominantly recruited through community engagement and ongoing communication using flyers, World Wide Web (e.g. social media) and in person promotion. Additional participants were recruited via the Australian Breastfeeding Association (ABA), local community health nurses and lactation consultants and through posts on the University of Western Australia website. Mothers already participating in research studies associated with Hartmann Human Lactation Research Group (HHLRG) under the supervision of Professor Peter Hartmann were also invited to participate.

Mothers were supplied with a consent form and general information sheet to complete at the time of milk collection (Appendix 2.1 and 2.2). Using the Visual Analogue Scale (VAS) for pain intensity as described by McClellan et al. (2012) mothers were asked to rate their pain when breastfeeding from 'no pain' to the 'worst pain imaginable'. Measured pain intensity was recorded and converted to a numerical value between 0 and 10, 0 being no pain and 10 representing the highest level of perceived pain.

Mothers were registered online with the HHLRG and provided with a unique identification number. Mothers received their identification number via email which contained a link directing them to an online questionnaire with questions relating to

parity, infant and maternal age, medication and current health status of the mother and infant. The questionnaire is provided in Appendix 2.3.

2.2.1.2 Human milk collection

Milk samples were collected from mothers with and without persistent nipple pain at a single time-point. Milk samples were collected from a single breast in mothers without nipple pain (control). Mothers with bilateral nipple pain provided a single milk sample from the breast experiencing the greatest level of perceived pain during breastfeeding. Mothers with unilateral nipple pain were asked to provide a sample from the affected breast and non-affected breast; this acted as a paired control.

Participating mothers were requested not to express or breastfeed for at least 3 hours prior to milk collection (most relevant to those presenting with unilateral nipple pain and therefore suitable to donate both a nipple pain and control sample) to ensure the breast was full or near full at the time of collection (Hassiotou et al, 2013), and/or required to provide a sample from the breast that had not recently expressed. Before collection mothers were required to adequately clean their hands (using Aqium antibacterial hand gel) and their breast to remove skin contaminants. The breast was washed by rinsing the nipple and surrounding skin with sterile water (DDI water that had been sterilised by autoclave at 120 °C for 15 minutes), followed by an alcohol wipe (70 % isopropyl alcohol) (Thermo Fisher Scientific Australia Pty Ltd.), a mild disinfectant (chlorhexidine) (Medical and Surgical Requisites Pty Ltd) and then a final rinse with sterile water before milk collection (Hale, Bateman, Finkelman & Berens, 2009). The breast pump and its attachments were sterilised in Quick Clean™ microwave sterilising bags (Medela, AG) prior to use. Participating mothers were

fitted with a breast shield connected to a Symphony® electric breast pump (Medela AG) and instructed to set the pump to a setting comfortable for them. A minimum of 15 ml of breast milk was collected and immediately put on ice, covered from light and transported to the laboratory for storage.

On arrival at the laboratory the samples were gently mixed and divided into three aliquots of 5 ml into 15 ml falcon tubes and stored at -80 °C until analysis.

For sample analysis purposes human participants were de-identified and given reference identification numbers, mothers were labelled M01-M29 with the addition of sample identification numbers separating the control (C01-C22) and NP (NP01-NP11) participants.

2.2.1.3 Participant demographic data analysis

Analyses of participant demographics were conducted to identify differences between control and nipple pain subgroups. Participant identification numbers and sample identification numbers are presented in the tables in the appendix.

Demographic analysis focused on maternal age, infant age and parity. All analyses were performed using R 3.0.3 GUI 1.638 Snow Leopard for Mac OSX (R Development Core Team, 2011) using the base packages, and the libraries NLME (Pinheiro, Bates, DebRoy & Sarkar, 2011) and multcomp (Hothorn, Bretz & Westfall, 2008), which were used for linear mixed modelling and multiple comparison of means, respectively. A linear mixed effect model and linear regression (linear model) were calculated and compared by ANOVA to determine underlying physiological

differences between individuals. Categorical variables, including parity, were compared using Fisher's exact test. Summary statistics are presented as mean \pm SD, or median (IQR), or proportion. $p < 0.05$ was considered to be statistically significant.

2.2.2 Bovine sample collection

A set of bovine milk samples, from healthy cows (control), cows suffering from mastitis and pooled samples from a single storage vat, were collected for comparative purpose to be used as positive control throughout the study. Milk samples were collected from Friesian Holstein (Black and White) dairy cows at a functional dairy in the south west of Western Australia. Pooled milk samples were collected by removing a 15 mL aliquot from a single storage vat prior to pasteurisation. Samples from individual cows were collected by hand expression of 15 ml of milk into a 25 ml falcon tube. All samples were sealed, covered from light, stored on ice and immediately returned to Perth for storage in an $-80\text{ }^{\circ}\text{C}$ freezer.

Bovine milk samples were collected from four lactating cows, given reference identification numbers B01-04, and the pooled bovine vat collections were labelled V01-V02. Additionally individual bovine samples were identified by sample identification numbers BC01-03 for bovine control samples, BM01-04 for samples retrieved from cows with mastitis and BV01-BV02 for the two pooled bovine vat samples.

2.2.3 Microbial methods

2.2.3.1 Media preparation

Mannitol Salt agar

Mannitol salt phenol red agar powder (Sigma-Aldrich Pty. Ltd., Australia) 111 g/L was prepared (in Millipore filtered double deionised distilled water). Agar solution was sterilized by autoclave (HS4406 Steam Sterilizer) (Getinge AB Group, Sweden) at 121 °C for 15 minutes and stored in 100 mm plates (50 plates, 25 ml per plate) below 8 °C.

Sabouraud Dextrose agar

Sabouraud Dextrose agar powder (Sigma-Aldrich Pty Ltd., Australia) 65 g/L was prepared (in Millipore filtered double deionised distilled water) and brought to boiling point until dissolved, using a PC-351 HOT plate Stirrer (Corning Incorporated, USA). Agar solution was sterilized by autoclaving (HS4406 Steam Sterilizer) (Getinge AB Group, Sweden) at 121 °C for 15 minutes and poured into 100 mm plates (50 plates, 25 ml per plate) below 8 °C.

2.2.3.2 Culture

Bacterial cultures were prepared in a laminar flow hood under sterile condition as recommended by the National Mastitis council (2012). 50 µl of each milk sample were spread evenly on each of the following agar plates in duplicate; 5 % Horse blood agar, Mannitol Salt agar (MSA) and Sabouraud Dextrose agar. Plates were incubated (3164 - Water Jacketed Incubator, Forma Scientific, USA) at 37 °C for 24 ± 2 hours; Sabouraud agar plates were incubated for an additional 96 hours.

A colony forming unit (CFU) count was conducted to determine total CFU/ml on 5% Horse Blood agar, MSA and Sabouraud agar. Bacterial species were identified by Gram stain with the help of Cristina Farrar (Senior Medical Scientist at Princess Margaret Hospital, Subiaco W.A.). *S. aureus* was identified based on positive latex agglutination test (to detect the coagulase enzyme) and positive culture on DNase *S. aureus* specific agar plate.

Additional agar plates Dichloran Rose Bengal Chlorotetracycline (DRBC) agar and Yeast Extract Glucose Chloramphenicol (YGC) agar (supplied by PMH) were used for specific isolation and identification of yeast species and Vogel-Johnson agar was used for the isolation and quantification of *S. aureus* following previous identification of target species (yeast and *S. aureus*) on Sabouraud agar and MSA respectively. All cultures were prepared following previously mentioned culture techniques, i.e. 50 µl of whole milk spread evenly on the agar plate and incubated at 37 °C for 24 ± 2 hours.

2.2.3.3 Bacterial and fungal species detection through Gram stain

Traditional Gram stain technique, as adapted from the original publication of Gram (1884) was used for microbial identification (Gram, 1884; Gephart et al., 1981). The colony of interest was transferred by loop onto a clean glass slide and heat fixed prior to applying a Gram stain. Using a Gram stain kit (Amber Scientific, Australia) the slide was flooded with crystal violet solution for up to a minute, washed briefly with distilled water and the excess water drained. Using Gram's iodide solution the slide was flooded again and left to sit for one minute before washing with distilled water

and draining. Using paper towel the slide was gently blotted dry and flooded for 10 seconds with decolourizer solution followed by washing with distilled water and draining. Lastly the slide was flooded with Safranin aqueous stain for 30 seconds. The slide was then washed using distilled water, followed by draining and blotting dry (being careful not to rub).

All slides were examined under an oil immersion lens and bacterial species were identified.

2.2.3.4 *S. aureus* identification

2.2.3.4.1 Latex agglutination test

The latex agglutination test was conducted to confirm the presence of *S. aureus* using a latex agglutination kit (Blackaby Diagnostics, Australia); following culture on blood agar and MSA.

Once a potential culture of *S. aureus* was identified on an MSA plate an inoculation loop was used to transfer a single colony to a latex agglutination card. A drop of red latex was added and the solution was mixed thoroughly using an inoculation loop followed by gently hand rocking the card for a further 20 seconds. Agglutination or clumping should be instantaneous with most *S. aureus* strains.

2.2.3.4.2 DNase agar plate

Additionally any potential *S. aureus* cultures identified on MSA plates were cultured on a DNase agar plate (supplied by Pathwest Laboratory Medicine, Australia). Using

an inoculation loop a single colony was transferred to a DNase agar plate and spread in a small circle on the surface of the agar. The plate was incubated (3164 - Water Jacketed Incubator, Forma Scientific, USA) for 24 hours at 37 °C followed by the addition of 1N HCl (Thermo Fisher Scientific Australia Pty Ltd.). The addition of HCl precipitates DNA in the media causing cloudiness, unless the DNA has been hydrolysed by *S. aureus* in which case creating a clear zone or 'halo' around the growing colony occurs, which indicates positive growth for *S. aureus*.

2.2.3.5 Data analysis

Data analyses of CFU/ml (as determined by culture on 5% horse blood agar) was performed using R 3.0.3 GUI 1.638 Snow Leopard for Mac OSX (R Development Core Team, 2011) using the base packages, and the libraries NLME (Pinheiro et al., 2011) and multcomp (Hothorn et al., 2008), which were used for linear mixed modelling and multiple comparison of means, respectively. Summary statistics are presented as mean \pm SD of the CFU/ml and logarithmic value of the CFU/ml. A p-value < 0.05 was considered to be statistically significant.

2.2.4 Sodium and potassium analysis

Sodium (Na^+) and potassium (K^+) ion analysis was based on a previous method using ion electrodes by Fetherston, Lai and Hartmann (2006). To determine the accuracy and reproducibility of the ion electrodes a set of concentration standards and calibration recovery standards were prepared and analysed prior to the analyses of the final sample set. Quality controls were used to identify unwanted variation such as the result of preparation or instrumental error (De Livera et al., 2012). Additional concentration standards and calibration recovery standards were analysed throughout

the final sample set to ensure that reproducibility within $\pm 10\%$ was being maintained.

Na^+ and K^+ concentration was measured using Horiba LAQUAtwin sodium ion electrode (S022) and Horiba LAQUAtwin potassium ion electrode (S030) (Horiba Scientific Ltd.). 300 μl from each sample was transferred by pipette onto the electrode and the reading was recorded (mV). The sample was removed and discarded and the electrode was washed using DDI water and dried with blotting paper and the process repeated. This method was used for the final sample set.

2.2.4.1 Preparation of concentration standards

A total of 10 sets of 7 preparation standards of known concentration were prepared, one set was used for method optimisation and the remainder were used for analysis of the final sample set.

A 25mM sodium/potassium (Na/K) stock was prepared by dissolving 1.461 g/L of NaCl (Univar®, USA) and 1.964 g/L of KCl (Univar®, USA) in 100 ml of (DDI) water. Using the 25 mM stock, Na/K standards between 0.5-25 mM were prepared in 15 ml falcon tubes as per Table 2.8.

The standards were divided into 1.5 ml aliquots using 2 ml centrifuge tubes and stored at $-20\text{ }^\circ\text{C}$ before use. Aliquots of the standards were used later to create a sodium and potassium standard curve to assist with calculation of sodium and potassium ion concentration in actual milk samples.

Table 2.8 Preparation of sodium and potassium standards for a standard curve.

Concentration (mM)	25mM Stock (ml)	DDI (ml)
0.5	0.2	9.8
2.5	1.0	9.0
5.0	2.0	8.0
10.0	4.0	6.0
12.5	5.0	5.0
17.5	7.0	3.0
25.0	10	0

2.2.4.2 Preparation of calibration recovery standards

A total of 10 sets of 3 calibration recovery standards was prepared, 3 sets were used for method optimisation and the remainder were used as part of the analysis of the final sample set.

A 15 mM Na/K stock standard was prepared in a 25 ml falcon tube by adding 12 ml of the previously made 25 mM Na/K stock to 8 ml of DDI. Using the 15 mM Na/K stock 10 sets (3 test tubes per set) of calibration recovery standards were dispensed in 2 ml centrifuge tubes as seen in Table 2.9. All aliquots were stored at -20°C.

Table 2.9 Preparation of calibration recovery standards.

Test tube	
1	750 µl of whole milk + 750 µl of 15 mM standard
2	750 µl of whole milk + 750 µl of DDI
3	750 µl of DDI + 750 µl of 15 mM standard

2.2.4.3 Method optimisation: recovery assay for calibration recovery standards

One full set of Na⁺/K⁺ standards (seven tubes) and three sets of calibration recovery standards (nine tubes) were removed from the freezer and incubated at room temperature for 5 minutes. Na⁺ and K⁺ concentrations in mV was measured and recorded in duplicate using the previously described method (2.2.4).

A logarithmic standard curve was prepared for the Na⁺ and K⁺ concentration standards. This was plotted on an XY graph (Figure 2.1 and Figure 2.2) and used to determine the unknown concentrations of the calibration recovery standards.

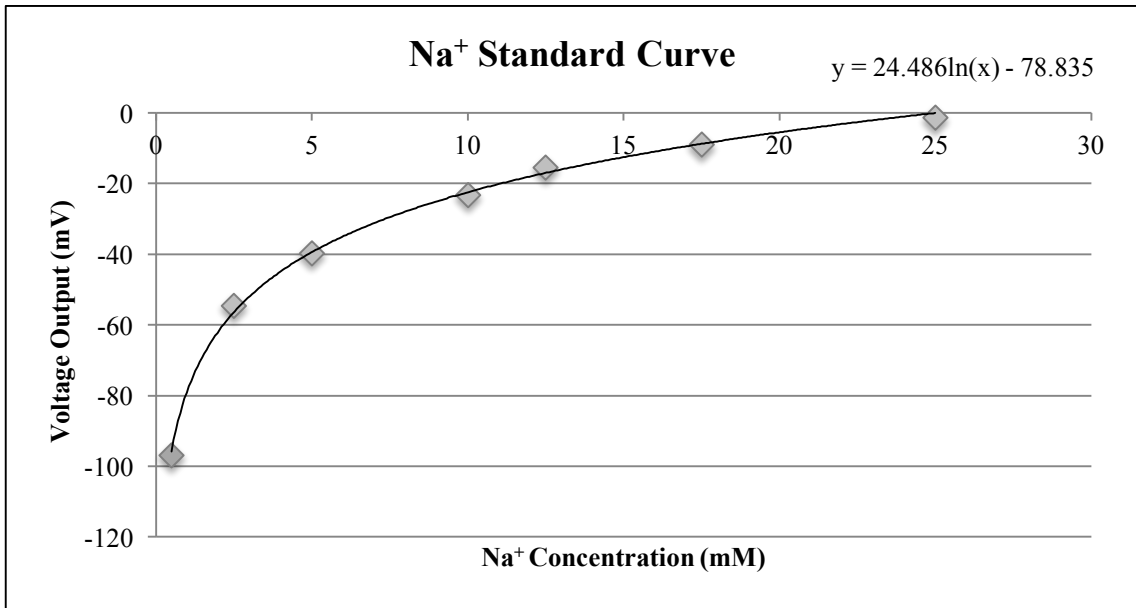

Figure 2.1 Na⁺ standard curve and logarithmic equation.

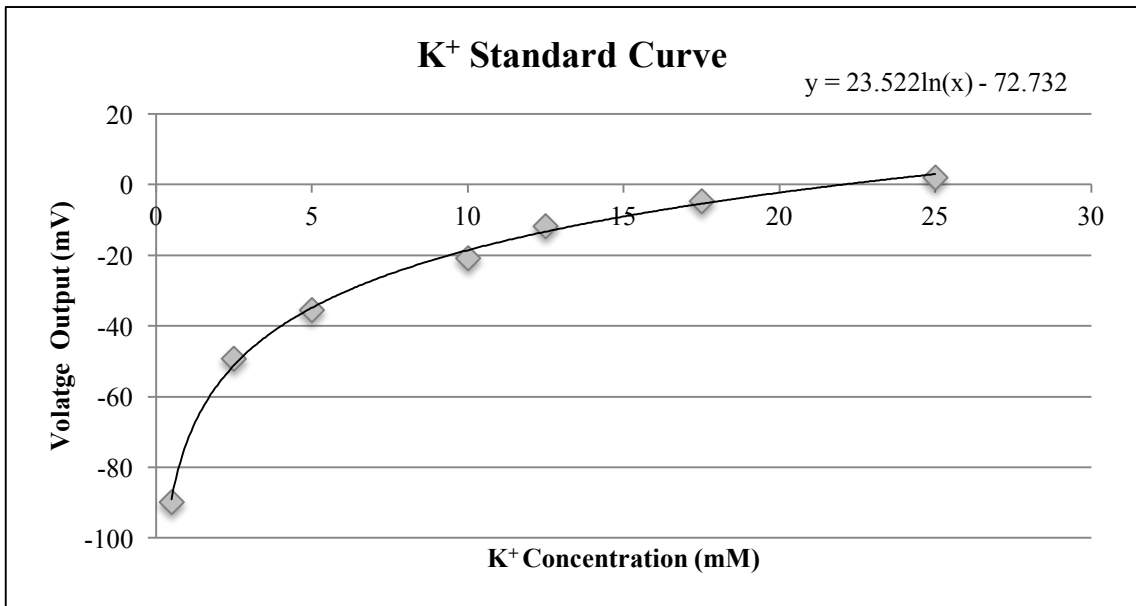

Figure 2.2 K⁺ standard curve and logarithmic equation.

To determine the accuracy and reproducibility of the electrodes, the calculation as seen in Figure 2.3 was used for each set of calibration recovery standards using the average concentration of the individual aliquot duplicates. A reproducibility of $\pm 10\%$ was considered acceptable.

$\frac{[\text{ONE (mM)} - \text{TWO (mM)}]}{\text{THREE (mM)}} = 1.00 = 100\%$
<hr/> <p>Example Calculation:</p> <p>Tube one: 13.59 mM Tube two: 7.05 mM Tube three: 6.43</p> $\frac{13.59 - 7.05}{6.43} = 1.02 = 102\%$

Figure 2.3 Reproducibility calculations for calibration recovery standards. Values ONE, TWO and THREE correspond with calibration recovery standards test tubes 1, 2 and 3 in Table 3.2.

Table 2.10 illustrates the reproducibility calculated for the initial three sets of calibration recovery standards. All sets produced reproducibility within $\pm 10\%$ and only five measurements displayed reproducibility less than $\pm 5\%$ (represented by the shaded cells in Table 2.10). These results were deemed satisfactory to move onto subsequent analysis.

Table 2.10 **Reproducibility of calibration recovery standards.**

Recovery set	Ion	Aliquot A	Aliquot B	Aliquot C
1	Na ⁺	1.02	0.99	1.01
	K ⁺	1.02	1.00	1.00
2	Na ⁺	0.99	0.97	1.04
	K ⁺	0.94	0.96	1.10
3	Na ⁺	0.95	1.00	0.92
	K ⁺	0.94	1.07	1.02

Reproducibility of less than ± 10 % is required for each set of calibration recovery standards.

Most samples had a % recovery less than 5 %.

Highlighted cells indicate reproducibility ≥ ± 5 %.

2.2.4.4 Measurement of Na⁺ and K⁺ ion concentration in milk

A set of concentration standards and calibration recovery standards were analysed each day prior to milk sample analysis. The calibration recovery standards were used to ensure reproducibility was being maintained and the concentration standards were used to calculate a logarithmic equation used to determine the Na⁺/K⁺ concentrations of the samples analysed on that day (total of four days of analysis).

The Na⁺ and K⁺ concentration of each milk sample was measured in mV and recorded in duplicate using the previously described method (2.2.4.). Readings were converted from mV to mM using the equation calculated from the sodium and potassium standards as previously explained. Once all Na⁺ and K⁺ measurements were converted to mM the Na⁺/K⁺ ratio was calculated [by dividing the Na⁺ concentration by the K⁺ concentration]. A Na⁺/K⁺ ratio level above 1 was considered abnormal and a sign of inflammation or possible infection (Aryeetey et al., 2008).

Following analysis of all milk samples and corresponding standards the equations for all standard curves was compared to identify any differences in concentrations that may have occurred between days (Figure 2.4 and Figure 2.5).

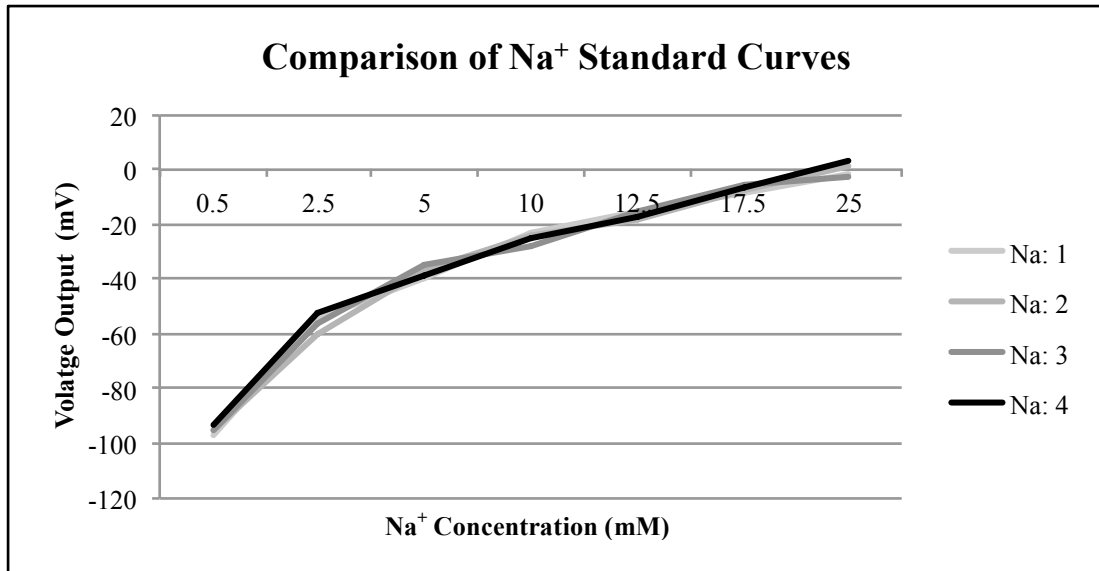

Figure 2.4 Comparison of Na⁺ standard curves.
This figure shows the reproducibility of the Na⁺ standard curve as measured on four separate occasions.

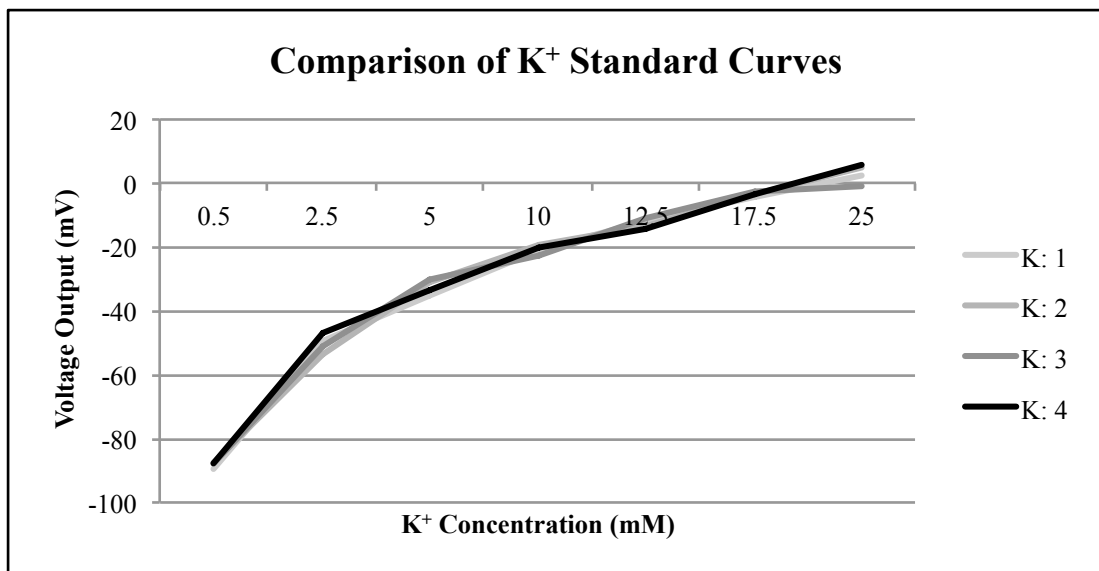

Figure 2.5 Comparison of K⁺ standard curves.
This figure shows the reproducibility of the K⁺ standard curve as measured on four separate occasions.

2.2.4.5 Data analysis

All samples were analysed for Na⁺ and K⁺ concentration and Na⁺/K⁺ ratios were calculated. All analyses were performed using R 3.0.3 GUI 1.638 Snow Leopard for Mac OSX (R Development Core Team, 2011) using the base packages, and the libraries NLME (Pinheiro et al., 2011) and multcomp (Hothorn et al., 2008), which were used for linear mixed modelling and multiple comparison of means, respectively. A linear mixed effect model and linear regression (linear model) were calculated and compared by ANOVA to determine underlying physiological differences between individuals. Summary statistics are presented as mean ± SD. A p-value < 0.05 was considered to be statistically significant.

2.2.5 Metabolomic profiling of human and bovine milk

Due to the complexity of human milk, together with the large variability between individuals, and the inherent difference between milk and other biological matrices, key components of the methods were optimised for the measurement of milk metabolites. The components requiring optimisation were the sample volume and the derivatisation reaction temperature.

Derivatisation allows the analysis of compounds that are not directly amenable to GC analysis. An increased volatility is one such benefit of derivatisation, and particularly for early eluting compounds, improved volatility can permit analysis in an otherwise obscured chromatographic background (Gullberg, Jonsson, Nordström, Sjöström, & Moritz, 2004). Within the literature a range of derivatisation reactions and conditions including temperatures and derivatisation reaction times has been used previously (Gummer, Trengove, Oliver and Solomon, 2013; Gullberg et al., 2004; Dunn et al., 2011; Bressanello et al., 2014).

Therefore, sample preparation optimisation, namely the incubation temperature for MSTFA derivatisation, and the optimal sample volume that can be analysed in a single derivatising volume, was carried out prior to the analyses of the final sample set.

2.2.5.1 Metabolite analyses

Polar metabolites were isolated from the milk using a solid phase extraction approach, following removal of the protein content by organic solvent precipitation. The dried

extract was then derivatised using a combination of oximation and silylation in preparation for instrumental analysis.

Proteins were precipitated by the addition of 1.2 mL ACN, added whilst gently mixing, and incubated at room temperature for 10 minutes. The precipitate was pelleted by centrifuging for 20 minutes at 10°C at 16,100 g. The supernatant (1,600 µl) was transferred into a fresh 2 ml centrifuge tube and the remaining pellet discarded. The supernatants were divided into two aliquots of 180 µl (equivalent to 50 µl of milk), which were frozen on dry ice and dried by lyophilisation. The remaining volume was stored at -80°C.

Samples were redissolved and fractionated by SPE according to the methods of Gummer and Trengove (Unpublished 2015). Specific details are not available due to intellectual property issues regarding patent of this method. Briefly, the method involves separating polar metabolites from non-polar. The polar fraction was then dried by lyophilisation in preparation for derivatisation. The remaining non-polar components were stored at -80°C for future studies.

Dried samples were derivatised in batches of 24, including QC samples, based on the methods of Gummer et al. (2013), but further optimised for milk analysis (in this thesis). A methoxyamine solution was prepared by dissolving 20 mg/ml of methoxyamine hydrochloride (Sigma-Aldrich Pty. Ltd.) in pyridine (Ajax Finechem). 20 µl was added to each sample and agitated at 1,200 rpm for 90 minutes at 30°C using an Eppendorf Thermomixer® Comfort (Crown Scientific Pty Ltd.). Samples were then centrifuged in a Microcentrifuge 5415R (Crown Scientific Pty Ltd.) for one minute at 18 °C and 16,100 g. The methoxymated sample solution was transferred to a glass analytical vial with a glass insert followed by the addition of a 5 µl solution of

n-alkanes C₁₀, C₁₂, C₁₅, C₁₉, C₂₂, C₂₈, C₃₂, C₃₆ (Chem Service Inc., USA), in n-hexane (95 %) (Thermo Fisher Scientific Australia Pty Ltd) for calculation of retention indices, and 40 µl of MSTFA (Sigma-Aldrich Pty. Ltd.). The vials were cap sealed and gently mixed using a vortex, IKA MS1 Works (Crown Scientific Pty Ltd.), before incubating in a 450-GC oven (Bruker Daltonics), pre-heated to 75°C, for 60 minutes. The samples were mixed on low using a vortex, IKA MS1 Works (Crown Scientific Pty Ltd.), at 15 minute intervals during this 60 minutes incubation period.

The vials were removed from the GC oven and set aside to rest for two hours before analysis by GC-MS.

The samples were analysed in random order including a 20 minute methanol blank between all samples and 60 minute methanol blank every four injections. QC samples were used to equilibrate the system ahead of sample analysis and analysed within the sample batch every fifth sample.

2.2.5.1.1 Milk volume optimisation for derivatisation

A series of 5 milk samples (from each of the sampling groups) were prepared in duplicate to determine the optimal volume for milk analysis by GC-MS; one human control, one nipple pain without trauma, one nipple pain with trauma, one bovine control and one bovine mastitis. Two 600 µl aliquots of each sample was used and prepared according to the protein precipitation method in 2.2.5.1. The resultant supernatant (1,600 µl) was dispensed into a 2 ml centrifuge tube and divided into two sets of four volumes 75, 150, 225 and 300 µl, sample volumes containing an equivalent volume of 25, 50, 75 and 100 µl of milk, respectively. Internal standards of

65 μl of 500 $\mu\text{g}/\text{ml}$ $^{13}\text{C}_6$ Sorbitol (Sigma Aldrich Pty. Ltd.) and 45 μl of 10 $\mu\text{g}/\text{ml}$ 2-aminoanthracene (Sigma Aldrich Pty. Ltd.) (in water) plus 1,455 μl of water (Thermo Scientific Australia Pty. Ltd.) was added to each sample. All samples were frozen on dry ice and dried by lyophilisation. One of each duplicate set of four was stored at -80°C for future studies.

Samples were redissolved and fractioned by SPE followed by derivatisation according to the methods in 2.2.5.1 Milk samples were analysed in random order using a Shimadzu QP2010 Ultra GC-MS (Shimadzu Corporation).

The optimal sample volume was determined with compromise between the detected signal (peak area) of each metabolite; particularly those present in smaller concentrations, instrument capability (efficiency and required preventive maintenance) and the ability to dissolve the dried metabolite extracts; with data reproducibility being the major deciding factor. The optimal equivalent volume of milk required was determined to be 50 μl ; this equivalent volume was used for all subsequent analyses.

2.2.5.1.2 Derivatisation temperature optimisation

Metabolite reference standard mixes (mix containing 30 metabolites, Table 2.5) were derivatised following the derivatisation method described in section 2.2.5.1, with the exception that after the addition of MSTFA (Sigma Aldrich Pty. Ltd.) each were incubated at one of five temperatures. The MSTFA derivatisation was assessed at the five temperature increments, 37°C , 45°C , 60°C , 75°C and 90°C , using a 450-GC oven (Bruker Daltonics). Two controls were also included for the 37°C and 60°C reaction

temperatures, which additionally varied from the described methods in that they were not transferred to glass vials before MSTFA addition. These two sets were heated in an Eppendorf Thermomixer® comfort (Crown Scientific Pty Ltd.) within 2 ml tubes for comparison to already established methods. Samples incubated within vials were sealed by crimp cap after the addition of MSTFA and gently mixed using a vortex, IKA MS1 Works (Crown Scientific Pty Ltd.) at 15 minute intervals during incubation. All were prepared in triplicate.

The vials were removed from the GC oven and Thermomixer and set aside to rest for two hours before analysis using a Shimadzu QP2010 Ultra GC-MS (Shimadzu Corporation).

Each reference metabolite peak was de-convoluted from the total ion chromatogram (TIC) and peak area(s) calculated using AnalyzerPro 2.7.0.0 (SpectralWorks Ltd.). The standard deviation was calculated using the measured technical replicates, which was plotted for each metabolite at each temperature and heating method. The optimal temperature was determined by the reproducibility of the triplicate measurements for each temperature. The optimal MSTFA derivatisation temperature was determined to be 75 °C; this temperature was used for all subsequent analyses.

2.2.5.2 Preparation of the final sample set (using the optimised methodology)

Milk samples were dispensed in 500 µl volumes into 2 ml centrifuge tubes. To each sample was added 26 µl of 500 µg/ml ¹³C₆ Sorbitol and 60 µl of 10 µg/ml 2-aminoanthracene (each in LC grade water), in a final volume of 600 µl (by the

addition of LC-MS grade water). Each were stored at -80°C and thawed on ice prior to preparation.

Milk samples were prepared by protein precipitation and fractioned by SPE to isolate the polar metabolites according to methods in 2.2.5.1, with a final dried down volume equivalent to 50 µl of milk. Dried samples were derivatised according to the method in 2.2.5.1. prior to analysis using a Shimadzu QP2010 Ultra GC-MS (Shimadzu Corporation).

For the purposes of quality control (QC), a second set of 500 µl aliquots was removed from the -80°C freezer and pooled by combining 175 µl from each of the 42 samples in a 10 ml falcon tube, followed by gently mixing using a vortex, IKA MS1 Works (Crown Scientific Pty Ltd.). The pooled QC milk was dispensed and prepared randomised among the samples described above.

2.2.5.3 Instrumentation and data acquisition

GC-MS analysis was carried out using a Shimadzu QP2010 Ultra GC-MS (Shimadzu Corporation, Kyoto, Japan) injected with 1µl of derivatised milk metabolites. The GC-MS was fitted with a FactorFour VF-5ms capillary column (30m x 0.25mm x 0.25µm + 10m EZ-Guard; Agilent, Santa Clara USA). The injection inlet temperature was set to 230 °C, with an interface temperature of 300 °C, and an ion source temperature of 230 °C. Helium was selected as the carrier gas and set to flow between 0.8 and 1.0 ml min⁻¹. Prior to sample injection the inlet pressure was adjusted to elute mannitol (6-TMS) at 30.6 minutes. The temperature gradient commenced at an initial temperature of 70°C, increasing at 1°C per minute for 5 minutes, then changing to an

oven ramp rate of 5.6 °C min⁻¹ with a 10 minute hold at the final maximum temperature of 320°C. Ionisation occurred by electron ionization (EI) at 70 eV. The mass spectrometer was operated in scan mode in the range m/z 40 – 600, at a scan rate of 5,600 amu sec⁻¹. For selected ion monitoring (SIM), ions were scanned at 0.38 second intervals.

2.2.5.4 Data analysis

GC-MSsolutions 2.61 (Shimadzu Corporation, Kyoto, Japan) was used to acquire and analyse the data post GC-MS metabolomic analysis. AnalyzerPro 2.7.0.0 (SpectralWorks Ltd.) was used for deconvolution. Appropriate qualifier and quantifier ions were determined from the MS and the full scan spectra searched again against the in house metabolite library and the already predetermined database (a list of tentative metabolite identifications compiled during method optimisation of the sample volume) of metabolite identities, for relative quantitation using the peak area of the analyte.

2.2.5.5 Data processing and interpretation

For the method optimisations, analyte peak areas were interrogated using JMP 8.0.2 (SAS Institute Inc.). For the metabolomics analyses, peak areas were normalised to the internal standard, ¹³C₆ sorbitol, and scaled to the median intensity (De Livera et al., 2012), range scaled and log transformed (log₁₀(x + 1) using The Unscrambler (Camo) software. Principal component analysis (PCA) was used to model the transformed data and PCA correlation loadings calculated using The Unscrambler (Camo).

3 Results

3.1 Human study population

Human milk samples were donated by 29 mothers from the Perth metropolitan area and its surrounds as well as the South West Region of Western Australia spanning 222 km (including Capel, Australind, Harvey and Bunbury) (Figure 3.1).

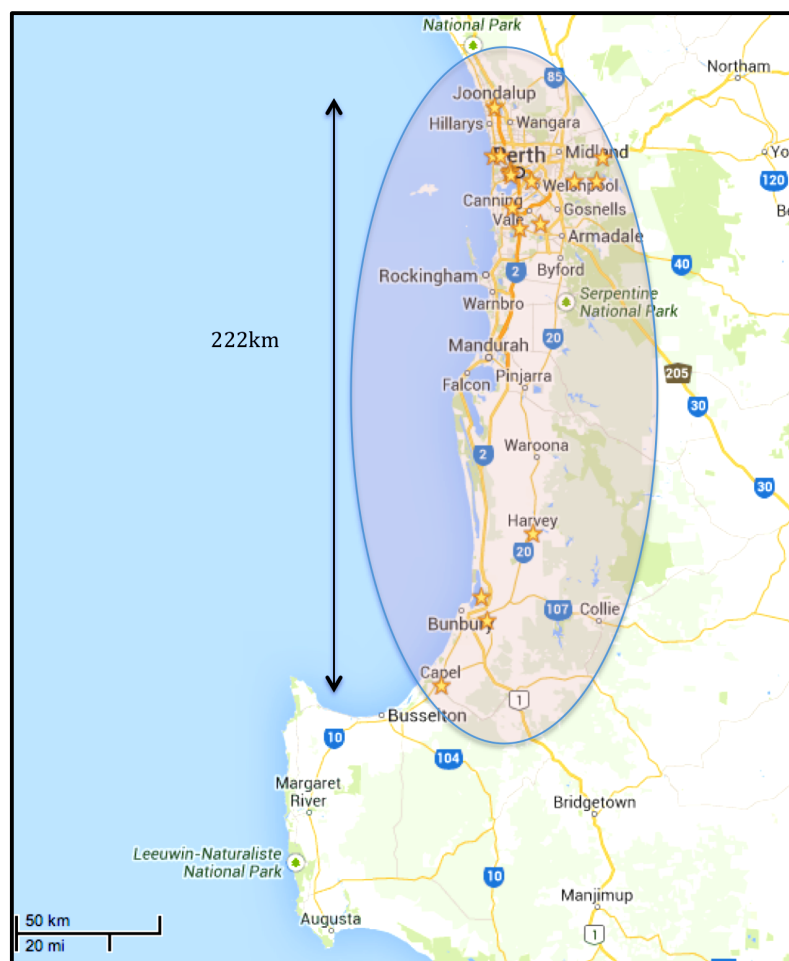

Figure 3.1 Sample collection area.
Where stars indicate locations of sample collection.
Reproduced from Google Maps (2015).

Milk samples were collected from women who had no pain (control group) and those with nipple pain (nipple pain group). The control group (CG) contained only mothers

who were experiencing pain-free breastfeeding and were used as the ‘healthy’ baseline for comparison with nipple pain samples. Nipple pain (NP) samples were collected from mothers who were experiencing persistent nipple pain during breastfeeding, determined by the perceived pain level during breastfeeding at the time of collection. Additionally participants with nipple pain were assessed for nipple trauma and breast changes (including abscess, broken nipple skin and suction lesions) and further divided into two subgroups; persistent nipple pain with no visible trauma (PG) and nipple pain with visible trauma (TG). Presence of trauma together with perceived pain levels were used as a general measure of breast health and potential damage to mammary tissue.

There were 4 mothers who were experiencing nipple pain in only one breast. These mothers donated samples from both breasts and provided both a nipple pain and a control sample. Three were in the Nipple Pain group (PG) and 1 was in the Trauma Group (TG).

All mothers were non-smokers during lactation and only one reported taking medication prior to sample collection. Mothers with infants outside the 1-6 month age (4-24 weeks) requirement were excluded from this study.

3.1.1 Sample demographics

A summary of all sample demographics is shown below in Table 3.1 (full demographic data set in Appendix 3.1). The mean age of the 29 mothers was 31.82 years (± 5.21) with a range of 22.2-40.8 years. Mothers in the NP group were on

average 2.86 years older than the CG ($p=0.16$), however there was no significant difference in maternal age between the CG and NP groups or subgroups.

Seventeen mothers reported the gestational age of their infant; of these mothers the mean gestational age was 39 weeks (median=39) with a range of 37 – 41 weeks.

Of the 29 infants, 11 were female and 18 were male.

The average age of the 29 infants in the study was 13.75 weeks (± 7.42) with a range of 4.6-26.1 weeks. The infant age in the NP group was an average 6.94 weeks younger than the CG group ($p=0.01$). The TG subgroup had the youngest mean infant age (9.02 ± 7.70 weeks) and was an average of 7.36 weeks younger than the CG ($p=0.04$) (Table 3.1). There was no significant difference in infant age between the PG and TG subgroups ($p=0.98$).

Of the 29 mothers 17 were multiparous; 13 had 2 children, 3 mothers had 3 children and only 1 had 4 children. There was no significant difference of parity between nipple pain subgroups.

3.1.2 Pain assessment

Using the Visual Analogue Scale (VAS) for pain intensity as described by McClellan et al. (2012), mothers with nipple pain were asked to rate their pain when breastfeeding from ‘no pain’ to the ‘worst pain imaginable’. Pain intensity was converted to a numerical value between 0 and 10, 0 being no pain and 10 representing the highest level of perceived pain. The control mothers ($n=22$) all reported a pain level of 0 during breastfeeding. Of the 11 mothers in the NP group, 6 mothers

reported a pain level of 5 or higher, with the 3 highest pain scores (10, 8, 8) reported from mothers experiencing persistent nipple pain with no visible trauma. Mean and SD of the PG and TG subgroups was 5.83 (\pm 3.25) and 5.0 (\pm 1.30) respectively. There was no significant difference in pain score between the two nipple pain subgroups (Table 3.1).

3.1.3 Medication

Participants were asked to document any medication they were taking at the time of collection. Some drugs have the potential to alter the transport processes in the mammary gland directly or by altering metabolism or normal developmental processes, which can directly affect the milk metabolome irrespective of patient health and breast pathology. Of the 29 mothers, only one mother (M18) reported taking an antibiotic at the time of collection; M18 was being treated for unilateral nipple pain without evidence of trauma (PG).

Table 3.1 Characteristics of infants and mothers in control group and nipple pain subgroups.

Characteristic	Control Group (CG) n = 18	Nipple Pain (PG) n = 6	Nipple Pain (TG) n = 5	All n = 29	p-value
Maternal Age (years)	30.73 (\pm 5.50)	33.43 (\pm 5.50)	33.79 (\pm 3.13)	31.82 (\pm 5.21)	0.37
Infant Age (weeks)	16.38 (\pm 6.83)	9.80 (\pm 6.00)	9.02 (\pm 7.70)*	13.75 (\pm 7.42)	0.43
Parity (n)	2 (1, 3)	1 (1, 4)	2 (1, 2)	2 (1, 4)	0.07
Pain (1-10)	0	5.83 (\pm 3.25)	5.2 (\pm 1.30)	5.55 (\pm 2.46)	-
Antibiotics (n)	0	1	0	1	-
Paired Samples (n)	-	3	1	4	-

Paired samples denote those where the mother also donated a control sample; mothers who donated both control and nipple pain samples are counted only in their relevant nipple pain subcategory.

Maternal age, infant age and perceived pain levels (nipple pain mothers only) are presented as a mean (\pm SD).

Parity is presented as median (IQR).

*P-value is ANOVA (continuous) or Fisher's exact test (categorical) comparison of all three groups. Significant differences between pain groups and control (reference) are indicated as: * = $p < 0.05$.*

3.2 Bovine study population

Seven bovine milk samples were collected from 4 lactating cows. Control and mastitis samples were collected from the same cow when possible; i.e. when only a quarter or more was presenting with mastitis, not the entire udder (Table 3.2). Each cow supplied up to three milk samples. Three control samples were collected from the quarters of three cows that did not appear to be suffering from mastitis at the time of collection, including one colostrum sample collected from a cow shortly after parturition. Four milk samples were collected from the quarters of three cows suffering from mastitis, one of which has been treated with Clavulox, an amoxicillin based penicillin antibiotic administered by direct injection into the affected quarter.

Two pooled milk samples were collected from a single storage vat prior to heat pasteurisation.

Table 3.2 **Distribution of bovine milk samples**

Test Group	Samples (n)	Treated (w/penicillin) (n)	Untreated (n)
Control	3	-	-
Mastitis	4	1	3

3.3 Microbe assessment results

Traditionally human milk has been cultured on a selection of selective and differential media to determine bacterial abundance and species composition. Australian milk banks, which follow United Kingdom guidelines for operating human milk banks, require all human milk to undergo microbial culture on 5% horse blood agar and CLED agar plates before and after heat pasteurisation (Hartmann et al., 2007).

Microbial testing is conducted for the identification and quantification (CFU/ml) of pathogenic organisms. Australian human milk banks standards require that donations do not contain enterococci, *Enterobacteriaceae* or any bacterial pathogen capable of producing heat-stable enterotoxins. Samples with confluent microbial growth exceeding 10^5 CFU/ml are deemed unacceptable for milk bank use (Hartmann et al., 2007).

S. aureus has traditionally been considered the most common etiological cause of nipple pain and mastitis, with recent studies also identifying coagulase negative staphylococcus (such as *S. epidermidis*) as being a possible factor in the development of breast pain and mastitis (Amir et al., 2011). Additionally the presence of *Candida albicans* and the development of breast thrush have been associated with breast and nipple pain in breastfeeding mothers (Brent, 2001).

For the purpose of this study three main media types together with traditional microbial analysis were used for primary identification and quantification of microbial and fungal organisms.

-
- i. 5% Horse Blood agar: A non-selective media suitable for all microbial growth and quantification of microbial species in CFU/ml.
 - ii. Mannitol Salt agar (MSA): A selective media for the isolation of staphylococci growth with the addition of a colour indicator differential for *S. aureus*.
 - iii. Sabouraud Dextrose agar: A selective medium used for the isolation and quantification of fungal species

Secondary microbial cultures were conducted using Vogel-Johnson agar to confirm identification of *S. aureus*. Additional subcultures on Yeast Extract Glucose Chloramphenicol (YGC) agar and Yeast Dichloran Rose Bengal Chlorotetracycline (DRBC) agar were used to confirm the identification of yeast on primary agar cultures.

Gram stain techniques were used to determine the identification of bacterial and fungal species. Additionally a latex agglutination test was used to confirm the identification of *S. aureus* on primary agar cultures following species detection by Gram stain.

Analysis of microbial organisms was used to identify possible causative agents contributing to persistent nipple pain with and without visible trauma.

3.3.1 Quantification of microorganisms

Microorganism growth was quantified and reported in CFU/ml, on 5% horse blood agar. Fungal and bacterial colonies were included in this quantification. The full data set is presented in Appendix 3.3. An average CFU/ml and standard deviation for each group was calculated (Table 3.3). The data was plotted to visualise spread and identify outliers (Figure 3.2). Subsequent culture on specific agars was used to confirm the identity of the organism present in primary cultures.

Of the 22 human control samples 21 produced positive culture on 5% horse blood agar, with a mean colony count of 1 623 CFU/ml (\pm 4 099). One sample had no growth. All of the samples in the nipple pain with trauma (TG) subgroup cultured positive on 5% horse blood agar. The TG samples showed the highest bacterial counts of the human participants; the mean CFU was 2 778 CFU/ml (\pm 5 265). All of the samples in the persistent nipple pain without evidence of trauma (PG) subgroup displayed positive culture on 5% horse blood agar. The PG group produced the lowest bacterial count with a mean CFU of 440 CFU/ml (\pm 289). The combined mean CFU for the nipple pain group was 1 503 CFU/ml (\pm 3 494). There was no statistical significance between groups ($p=0.55$).

All bovine samples ($n=9$) cultured positive on 5% horse blood agar with a combined mean CFU of 11 098 CFU (\pm 540). The bovine mastitis samples (BM) ($n=4$) had a mean CFU of 2 173 (\pm 2775), higher than the bovine control group (BC) ($n=3$) with a mean CFU of 473 CFU/ml (\pm 519). The pooled bovine samples (BP) ($n=2$) (collected from a single storage vat) displayed the most abundant microbial growth with a combined CFU of 44 885 CFU/ml (\pm 13 584).

As a result of the small sample size the log form of the CFU/ml was calculated to scale the data and remove the influence of outliers (Figure 3.2, Table 3.3). Figure 3.2 illustrates the large variation in CFU/ml of the human control samples. Despite individual control samples having the samples with the largest CFU/ml the log of the CFU/ml is lowest in the control group as indicated by black markers, Figure 3.2.

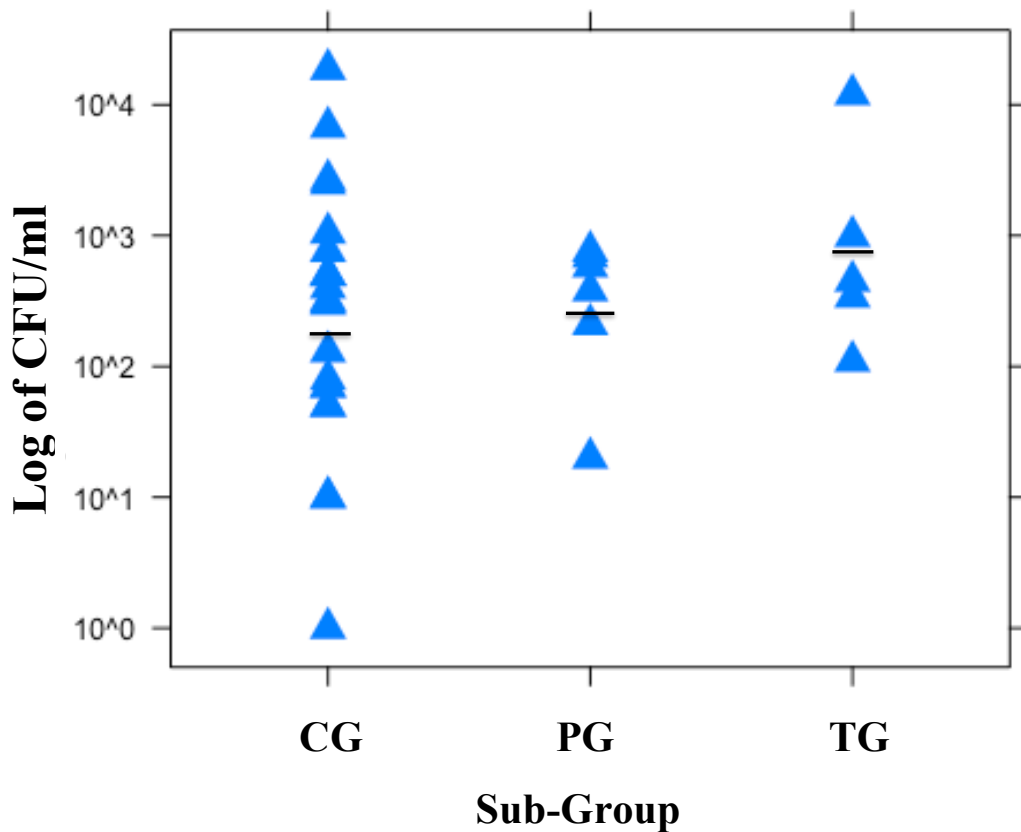

Figure 3.2 Log of the CFU/ml in human whole milk cultured on blood agar. Individual sample counts are represented as triangle. The mean of each group is represented by a black bar. (CG; human milk, control samples, PG; human milk, persistent nipple pain without trauma, TG; human milk, persistent nipple pain with evidence of trauma.

Table 3.3 Number of microorganisms in human and bovine whole milk samples from blood agar cultures.

	Control Group (CG) n = 22	Nipple Pain (PG) n = 6	Nipple Pain (TG) n = 5	All n = 33	Bovine Control n = 3	Bovine Mastitis n = 4	All n = 9
CFU/ml	1 623 (± 4 099)	440 (± 289)	2 778 (± 5 265)	1 583 (± 3 853)	473 (± 519)	2 173 (± 2 775)	1 357 (± 1 833)
Log of CFU/ml	2.37 (± 0.98)	2.45 (± 0.60)	2.86 (± 0.76)	2.48 (± 0.88)	2.37 (± 0.98)	2.64 (± 0.68)	2.48 (± 0.88)

CFU/ml and log of CFU/ml are presented as mean ± SD.

3.3.2 Identification of microorganisms

Following microorganism quantification on 5% blood agar, bacterial and fungal species were identified by Gram stain. Gram staining and oil immersion microscopy identified bacterial and fungal species. Specific identification of bacteria and yeast species was made by use of selective media.

3.3.2.1 5% *Horse blood agar*

5% horse blood agar is an enriched growth medium containing a variety of complex nutrients suitable for the growth of most bacterial and fungal species and the detection of haemolytic activity. Blood agar is often used to identify haemolytic streptococcus.

Blood agar culture of human and bovine milk samples resulted in cultures of a variety of morphologies and species were identified based on morphology and Gram stain. *S. aureus* was only identified in one human sample. *S. aureus* was identified in one bovine sample and both pooled bovine vat samples.

Mothers presenting with unilateral nipple pain supplied a sample from their affected and unaffected breast. Figure 3.3 is an example of a mother (M18) who was experiencing persistent nipple pain without evidence of trauma in one breast. Pictured are blood agar cultures of the control and nipple pain milk samples she provided.

Plate A is a blood agar culture of milk from her non-affected breast (control) and Plate B is a blood agar culture of milk from the affected breast. Plate A indicates no growth of pathogenic microorganisms. Two bacterial species were identified, *Corynebacterim diphtheria* (blue circles) and CNS (white circles). Both species are

commonly found in human and bovine milk, CNS in particular was found in 91 % of the human milk samples in this study. A blood agar culture of the donor's affected breast (Plate B), which was experiencing persistent nipple pain without visible trauma identified 82 % *S. aureus* colonies with 18 % other species (predominately CNS). This is the only human milk sample where *S. aureus* was detected. Fungi were not identified in any human milk samples.

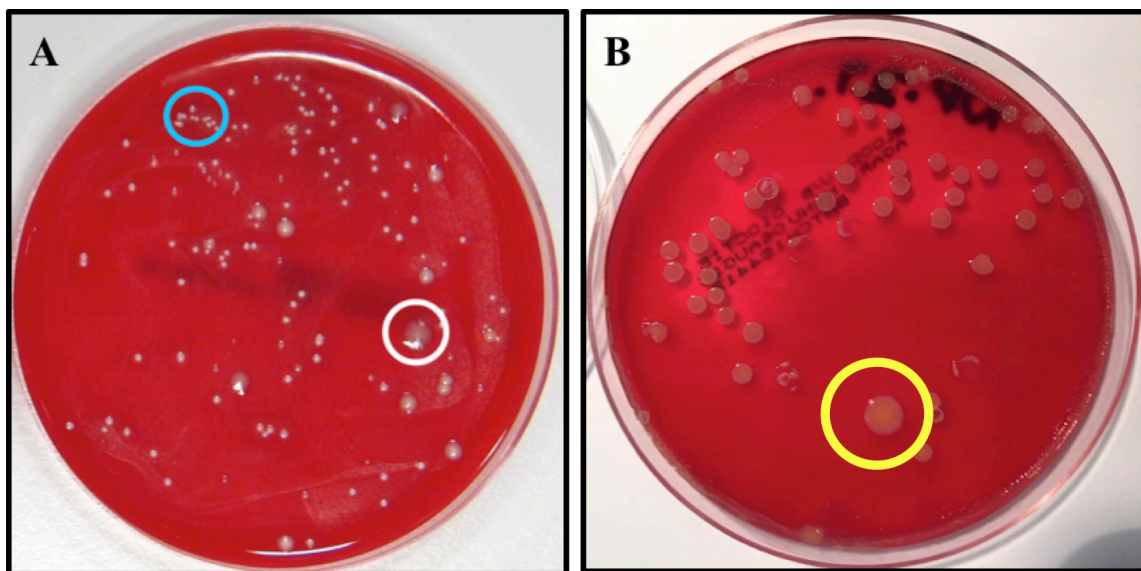

Figure 3.3 Blood agar cultures of human milk, control and nipple pain. Plate A is a culture of a control sample and Plate B a culture of a nipple pain sample, which were collected from a single mother who was experiencing unilateral nipple pain (M18). Plate A: Blue circle; *Corynebacterium diphtheria* ssp. and white circle; strains of CNS. Plate B: Yellow circle; *S. aureus*.

Organisms most likely thought to cause pain such as yeast and *Streptococcus* ssp. were found only in pooled bovine vat samples (Figure 3.4 and 3.5, respectively) and identified using Gram stain techniques.

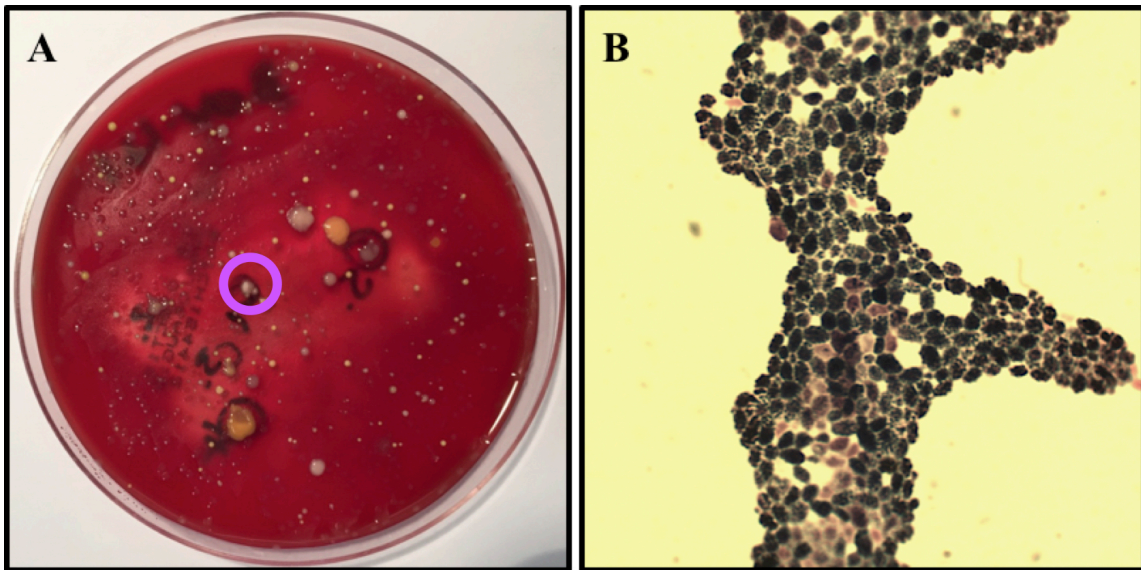

Figure 3.4 Blood agar culture and Gram stain of a bovine vat sample (BV02).
The purple circle indicates a yeast colony as presented in the Gram stain on the right.

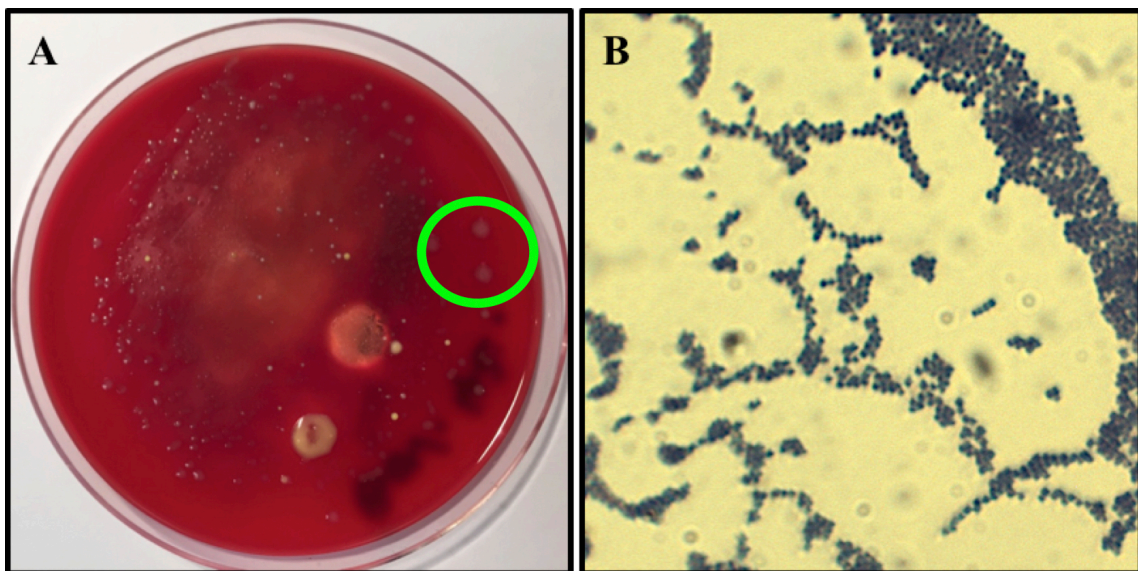

Figure 3.5 Blood agar culture and Gram stain of a bovine vat sample (BV01).
The green circle indicates enlarged streptococcus colonies as presented in the Gram stain on the right.

3.3.2.2 Mannitol salt agar

All samples were cultured on MSA to confirm the presence of *S. aureus* and to verify if *S. aureus* growth was restricted or overlooked on primary agar cultures, on 5% blood agar. MSA is a selective media for Gram-negative bacteria and staphylococci, but more specifically for the selective identification of *S. aureus*. MSA contains the pH indicator phenol red for the specific detection of *S. aureus*, which causes the agar to turn yellow (Figure 3.6). *S. aureus* was identified in one human milk sample which was donated by a mother experiencing unilateral persistent nipple pain with no trauma (M18), a bovine sample from a cow presenting with mastitis which had not been treated with antibiotics (BM01), and both pooled vat samples (BV01/02).

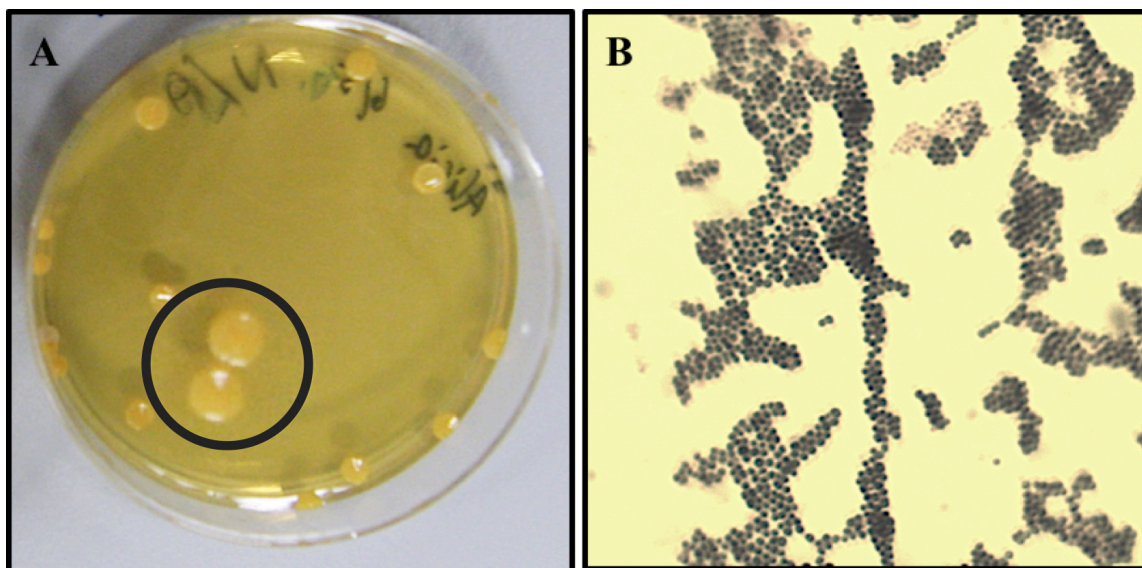

Figure 3.6. MSA culture and Gram stain of a human milk sample from a mother (M18) experiencing persistent nipple pain (PG).
The culture was 100% S. aureus colonies (360 CFU/ml). B: Gram stain of S. aureus; colony indicated by the black circle in image A.

3.3.2.3 *Vogel-Johnson agar*

Samples previously identified to contain *S. aureus* growth were cultured on Vogel-Johnston agar to confirm the presence of *S. aureus* and to ensure *S. aureus* growth wasn't restricted or overlooked on 5% horse blood agar or MSA cultures.

Vogel-Johnson is selective for coagulase positive, mannitol fermenting staphylococcus and thus is used for the clinical identification of *S. aureus*. *S. aureus* begin to appear after 24 hours of incubation and form characteristic black colonies (Figure 3.7). *S. aureus* was positively identified in one human milk sample (M18), donated by a mother suffering unilateral persistent nipple pain without visible trauma (Figure 3.7). Additionally *S. aureus* was identified in one individual bovine sample (BM01), collected from a cow presenting with mastitis and both pooled bovine vat samples (BV01 and BV02) (Figure 3.7).

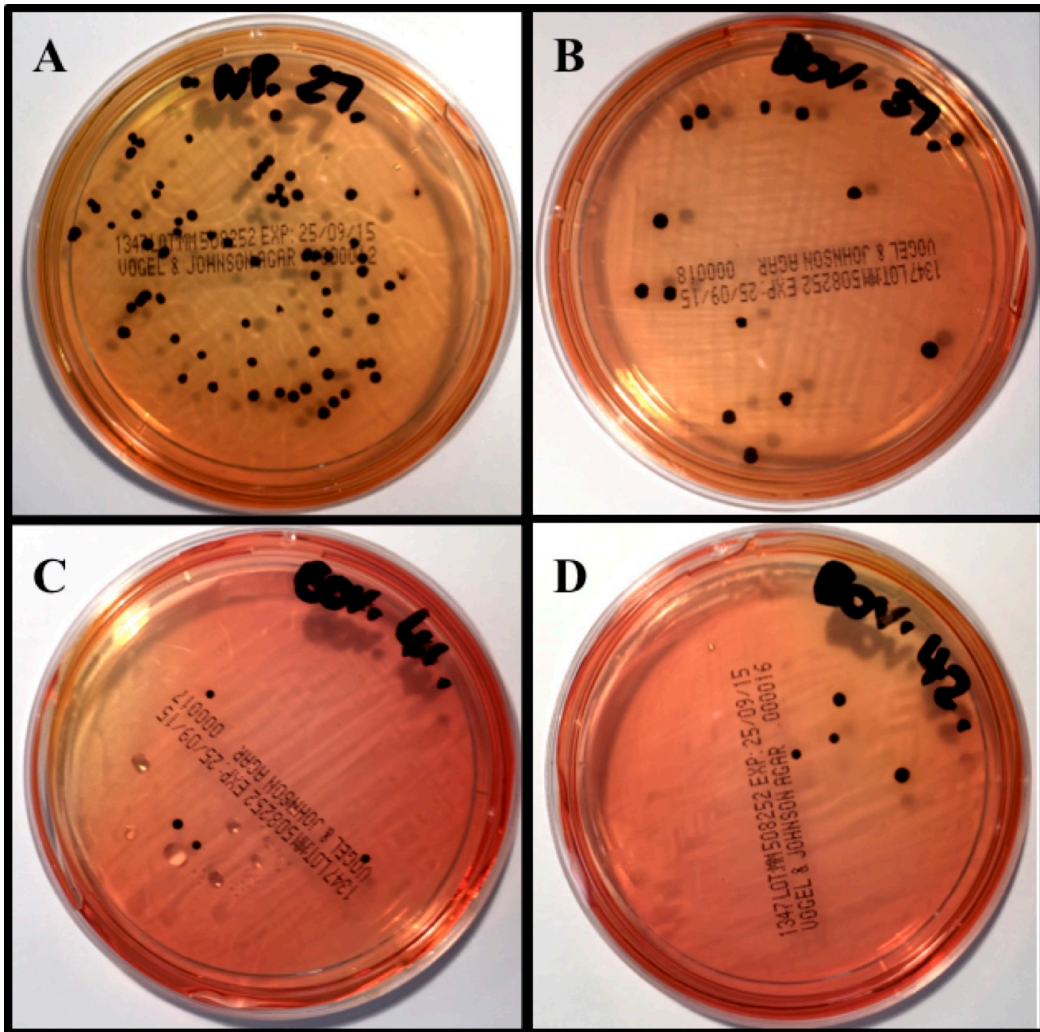

Figure 3.7 Vogel Johnson cultures of human and bovine milk samples. Plate A is a culture of a human milk sample from a mother with persistent nipple pain without trauma (M18), Plate B is a culture of a bovine milk sample from a cow suffering from mastitis (BM01) and Plates C & D are cultures from each of the bovine vat samples (BV01 & BV02).

3.3.2.4 *S. aureus* specific DNase agar plate

The DNase agar plate was also used to positively identify *S. aureus*. The microbe is able to use the DNA in the agar as a source of carbon and energy for growth. This is accomplished by the use of a DNase enzyme which is specific for *S. aureus*. The presence of a clear halo surrounding the targeted colony indicates a positive test for *S. aureus*, as shown in Figure 3.8. The presence of *S. aureus* was confirmed in one human milk sample (NP02) collected from a mother in the PG group and 3 bovine samples, one individual bovine sample (BM01) and both pooled bovine vat samples (BV01 and BV02).

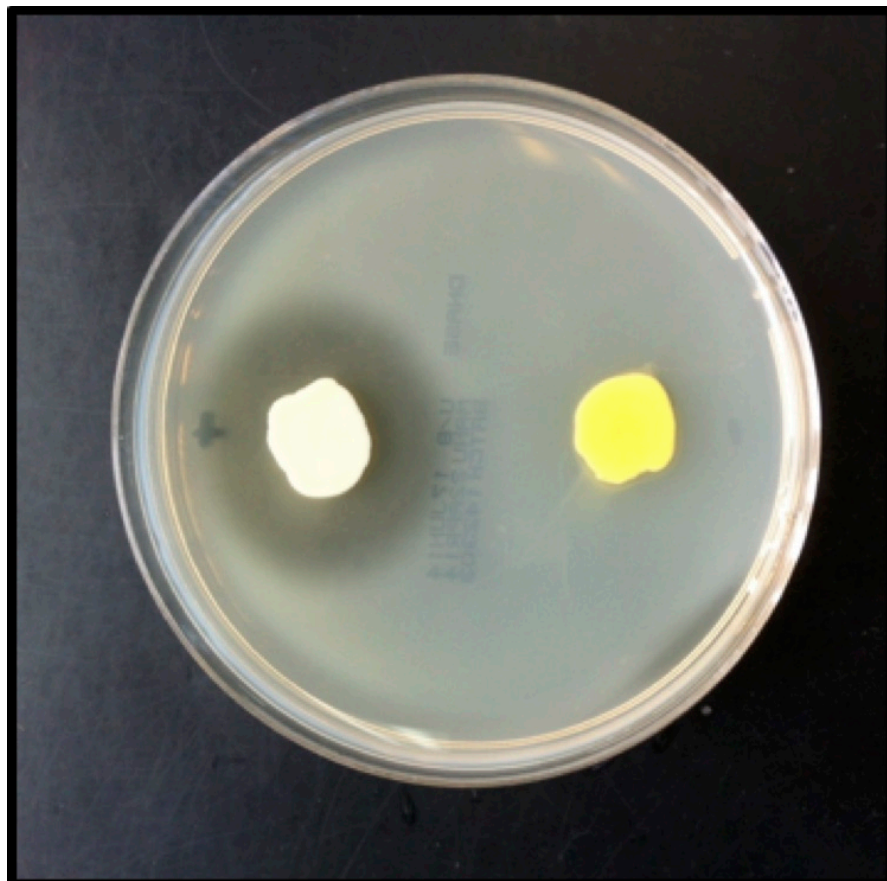

Figure 3.8 DNase agar plate used for the identification of *S. aureus*. The sample shown on the left is from a mother presenting with nipple pain with no trauma. This sample shows a distinct halo around the colony and indicates a positive test for *S. aureus*; the sample on the right is a negative control.

3.3.2.5 Latex agglutination test

Gram staining and microscopy under oil immersion was used to confirm the identification *S. aureus* prior to employing the latex agglutination test. The latex agglutination test was used to confirm the presence of *S. aureus* via the detection of the coagulase enzyme in the microorganism. Coagulase present in the sample interacts with the latex particles and produces visible agglutination (Figure 3.9C). The latex agglutination test was used in conjunction with MSA, Vogel-Johnson agar and *S. aureus* specific DNase agar to confirm definitively the presence of *S. aureus*. It was confirmed that one human milk sample (NP02) contained *S. aureus* and three bovine samples, one individual (BM01) and both pooled bovine vat samples (BV01 and BV02) were also confirmed to contain *S. aureus*. No additional sample tested positive for *S. aureus* growth.

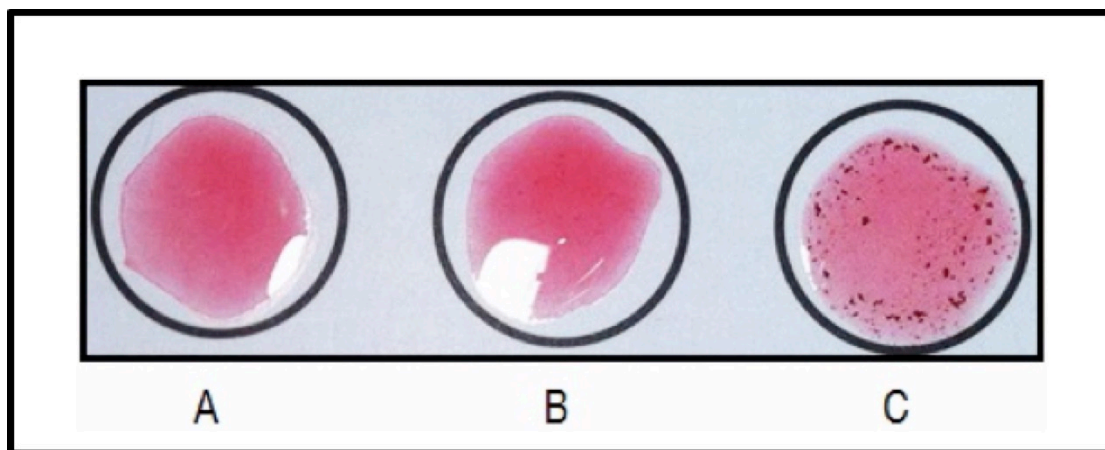

Figure 3.9 The Latex agglutination test for the detection of *S. aureus*. Position C on the oxoid card indicates a positive result for *S. aureus*; in a sample from a mother experiencing persistent nipple pain with no visible trauma.

3.3.3 Fungal species identification

Following the identification and quantification of microorganisms on 5% horse blood agar, all whole milk samples were cultured on Sabouraud agar for the identification and quantification of fungal species. Following the identification of fungal species on Sabouraud agar, select whole milk samples were cultured on Yeast Extract Glucose Chloramphenicol (YGC) agar and Dichloran Rose Bengal Chlorotetracycline (DRBC) agar to confirm the presence of fungal species.

3.3.3.1 Sabouraud Agar

Sabouraud agar was used for the identification of fungal species, more specifically to determine the presence of any *Candida* ssp. often thought to cause breast pathology. No human milk sample cultured positive for the growth of any fungal species. The pooled bovine vat samples (BV01 and BV02) were the only samples to culture positive for fungal species (Figure 3.10).

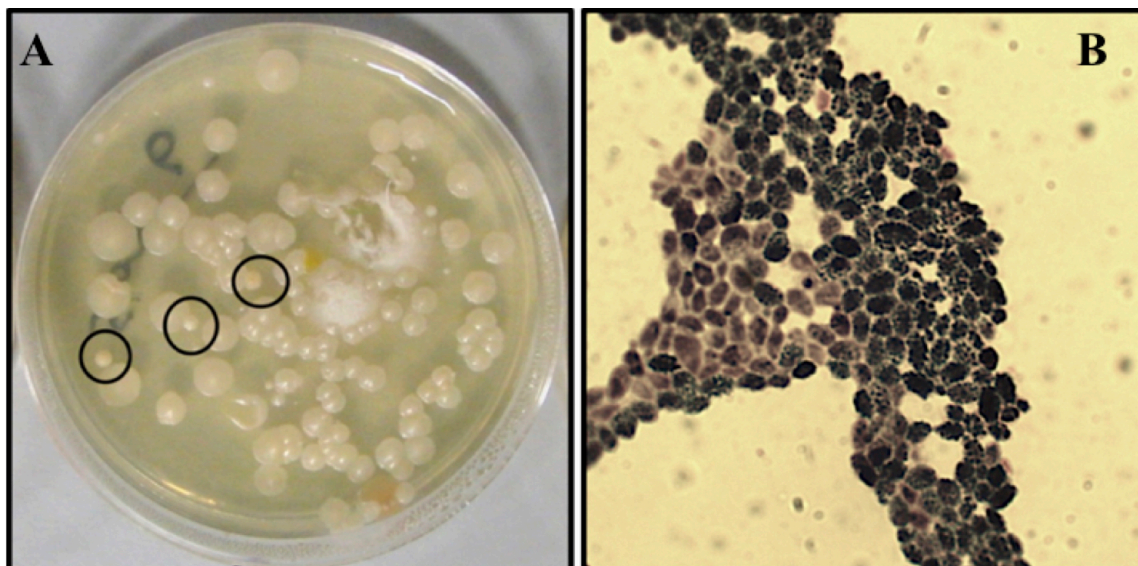

Figure 3.10 Sabouraud agar culture and Gram stain of a bovine milk sample. *The bovine milk sample (BV02) was collected from a storage vat prior to pasteurisation. A: Black circles indicate yeast colonies. B: Gram stain of yeast colony.*

3.3.3.2 *Yeast Extract Glucose Chloramphenicol (YGC) agar and Dichloran Rose Bengal Chlorotetracycline (DRBC) agar*

YGC and DRBC agar are selective for the growth of fungi and contains chloramphenicol to inhibit the growth of accompanying bacterial species. YGC and DRBC agar are used for the isolation and quantification of yeast. Bovine vat samples (BV01/B02) were positive for the growth of yeast. Figure 3.11 are YGC and DRBC cultures of BV01 and illustrate positive growth of yeast as indicated by the black circles. No human samples were positive for yeast on YGC or DRBC agar.

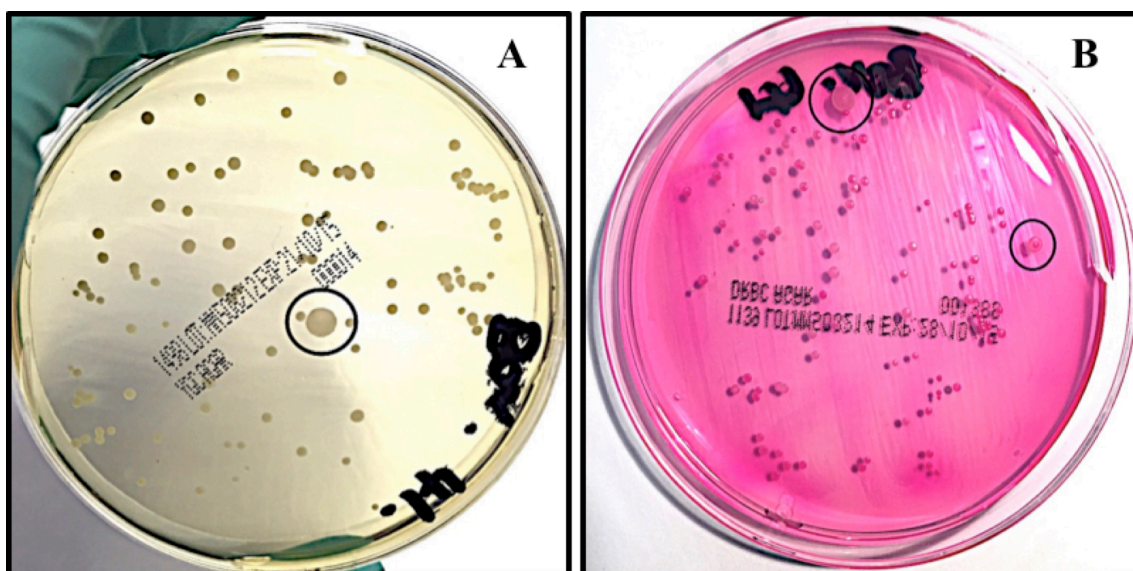

Figure 3.11 YGC and DRBC agar cultures of a single pooled bovine vat sample (BV01).

The bovine milk sample was collected from a storage vat prior to pasteurisation. A: YGC agar culture; The black circle indicates a yeast colony. B: DRBC agar culture; Black circles indicate yeast colonies.

3.3.4 Microbial diversity

The following microorganisms were positively identified: Coagulase negative staphylococcus ssp., *Corynebacterium diphtheria*, *S. aureus*, *Micrococcus ssp.*, *Streptococcus ssp.*, *Bacillus ssp.* and yeast ssp. A summary of the distribution of bacterial and fungal species identified in the human and bovine samples are presented in Table 3.4.

S. aureus was only identified in one human sample, from the PG (subgroup), and one bovine sample, from a cow with untreated mastitis, and both pooled bovine vat samples collected from the storage vat prior to heat pasteurisation. Only the pooled bovine vat samples displayed growth of *Streptococcus ssp.* and yeast.

Table 3.4 **Distribution of bacterial and fungal species between groups.**

Group	Microorganism species identified
CG	Coagulase negative staphylococcus ssp., <i>Corynebacterium diphtheria ssp.</i> and <i>Bacillus ssp.</i>
PG	Coagulase negative staphylococcus ssp., <i>Corynebacterium diphtheria ssp.</i> , <i>S. aureus</i> , <i>Micrococcus ssp.</i>
TG	Coagulase negative staphylococcus ssp., <i>Corynebacterium diphtheria ssp.</i> , <i>Micrococcus ssp.</i>
BC	Coagulase negative staphylococcus ssp., <i>Corynebacterium diphtheria ssp.</i> and <i>Bacillus ssp.</i>
BM	Coagulase negative staphylococcus, ssp., <i>Corynebacterium diphtheria ssp.</i> , <i>S. aureus</i> , <i>Micrococcus ssp.</i> and <i>Bacillus ssp.</i>
BP	Coagulase negative staphylococcus ssp., <i>Corynebacterium diphtheria ssp.</i> , <i>S. aureus</i> , <i>Micrococcus ssp.</i> , <i>Streptococcus ssp.</i> , <i>Bacillus ssp.</i> and yeast ssp.

The table is divided into human and bovine subgroups.

3.4 Sodium and potassium ion analysis

Elevated sodium ion concentration in milk has been used previously as a measure of breast health and damage to mammary tissue (Filteau et al., 1999). However, as milk composition is highly variable between individuals it was proposed that potassium concentration be used as a baseline and a sodium to potassium ratio used as a new measure of breast pathology (Aryeetey et al., 2008). This study measured the sodium and potassium concentration in all samples and determined the sodium/potassium ratio, an elevated sodium to potassium ratio above 1.0 was considered indicative of infection and mastitis (Aryeetey et al., 2008).

3.4.1 Measurement of sodium and potassium in human and bovine milk samples

The sodium (Na^+) and potassium (K^+) ion concentrations and sodium to potassium ratio (Na^+/K^+) was recorded for the duplicates of all human and bovine samples. The mean (\pm SD) for Na^+ and K^+ concentration and Na^+/K^+ ratio were calculated for the human control and nipple pain subgroups, and is shown in Table 3.5 (complete sample set in Appendix 3.4).

The TG subgroup had a mean Na^+ concentration of 8.01 mM (\pm 2.40), which was on average 2.23 mM (\pm 0.93) higher than the PG group ($p=0.056$). The TG had a significantly higher Na^+ concentration than the control group which was on average 3.77 mM (\pm 0.76) lower than the TG subgroup ($p<0.001$).

Analysis of the K^+ concentration in milk found that both the PG and TG subgroups had a higher mean concentration than the control group, 13.55 mM and 14.45 mM vs. 12.72 mM, respectively. However, there was no statistically significant difference between the control and nipple pain group or subgroups ($p=0.053$).

Calculation of the Na^+/K^+ ratio found that the TG subgroup had the highest mean ratio (0.55 ± 0.15), which was significantly higher than the control group (0.34 ± 0.09) ($p<0.001$). The mean ratio for the TG subgroup was higher than the PG subgroup (0.43 ± 0.11), however no significant difference in Na^+/K^+ ratio was found between the subgroups ($p=0.10$).

Table 3.5 Summary of Na⁺ and K⁺ concentrations and Na⁺/K⁺ ratio recorded for human milk samples.

	Control Group (CG) (n=22)	Nipple pain (PG) (n=6)	Nipple Pain (TG) (n=5)	All (n=33)	p-value
Na⁺ (mM)	4.32 (±1.18)	5.81 (±1.94)*	8.04 (±2.40)†	5.15 (±2.02)	0.0001
K⁺ (mM)	12.72 (±1.23)	13.55 (±1.98)	14.45 (±1.64)*	13.13(±1.54)	0.0530
Na⁺/K⁺ ratio	0.34 (±0.09)	0.43 (±0.11)	0.55 (±0.15)†	0.39 (±0.13)	0.0005

*P-value calculated by ANOVA (continuous) comparison between all three groups. Significant differences between pain groups and control (reference) are indicated as: * = P<0.05, † = P<0.001.*

Data are presented as mean ± SD.

Despite the TG (0.55 ± 0.15) and PG (0.43 ± 0.11) subgroups displaying a higher mean Na^+/K^+ ratio than the control group (0.34 ± 0.09), no sample had an elevated ratio above one, a cut off previously considered to be indicative of infection (Figure 3.12). The highest Na^+/K^+ ratio was 0.811 recorded for M26/NP07 in the TG subgroup.

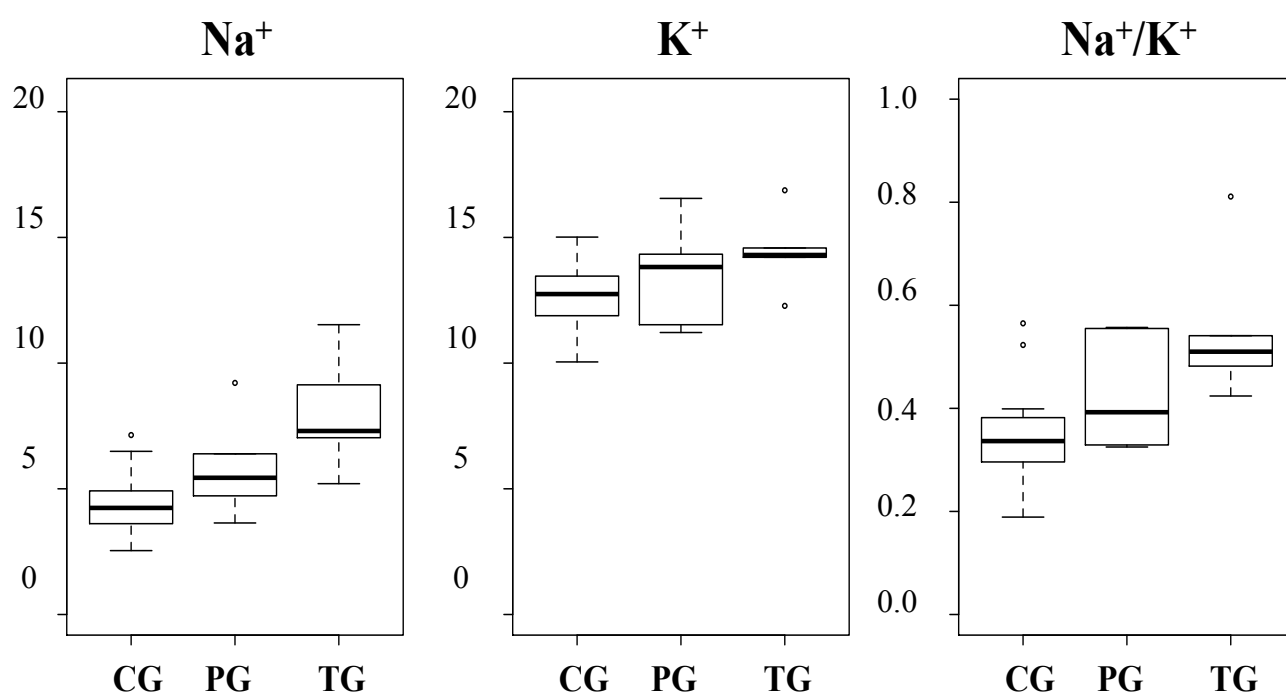

Figure 3.12 Box plots of Na^+ and K^+ concentration and Na^+/K^+ ratio. Samples are shown in groups (CG: control, PG: nipple pain and TG: nipple pain with trauma subgroup). Box plots illustrating median, quartiles, range and outliers (°).

The mean Na^+ concentration for the bovine samples (n=9) was 21.63 mM (± 11.44). The bovine control group (n=3) had a mean Na^+ concentration of 16.86 mM (± 7.4) and the bovine mastitis group had a Na^+ concentration of 30.26 mM (± 11.07) with the highest Na^+ concentration measured for a cow with untreated mastitis (45.48 mM). The two vat samples had an average Na^+ concentration of 11.54 mM (± 0.01).

The mean K^+ concentration for the bovine group (n=9) was 21.75 mM (\pm 4.29). The mean K^+ concentration for the bovine control samples was 23.68 mM (\pm 2.36), which was higher than the bovine mastitis samples (19.08 \pm 5.29 mM). The two vat samples had an average K^+ concentration of 24.21 mM (\pm 0.22).

The average Na^+/K^+ ratio for the bovine samples (n=9) was 1.16 (\pm 1.0). The bovine control group had a mean Na^+/K^+ ratio of 0.73 (\pm 0.34). The bovine mastitis group had the highest mean ratio (1.82 \pm 1.22); a cow with untreated mastitis had the highest ratio (3.56). A summary of the results are shown in Table 3.6.

Table 3.6 Summary of Na^+ and K^+ concentration and Na^+/K^+ ratio recorded for Bovine milk samples.

	Control (n=3)	Mastitis (n=4)	Vat (n=2)	All (n=9)
Na^+ (mM)	16.86 (\pm 7.4)	30.36 (\pm 11.07)	11.54 (\pm 0.02)	21.63 (\pm 11.44)
K^+ (mM)	23.68 (\pm 2.36)	19.08(\pm 5.29)	24.21 (\pm 0.22)	21.75 (\pm 4.49)
Na^+/K^+ ratio	0.73 (\pm 0.34)	1.83 (\pm 1.22)	0.48 (\pm 0.004)	1.16 (\pm 1.0)

Data is shown as mean (\pm SD).

The human and bovine samples were plotted together to identify trends in the data (Figure 3.13). The human samples were plotted as box plots for the control and nipple pain groups, the bovine samples are indicated by red stars. It is important to note that only the Na^+/K^+ ratio is comparable. Figure 3.13 identifies that both the human nipple pain and bovine mastitis samples have an elevated Na^+/K^+ ratio.

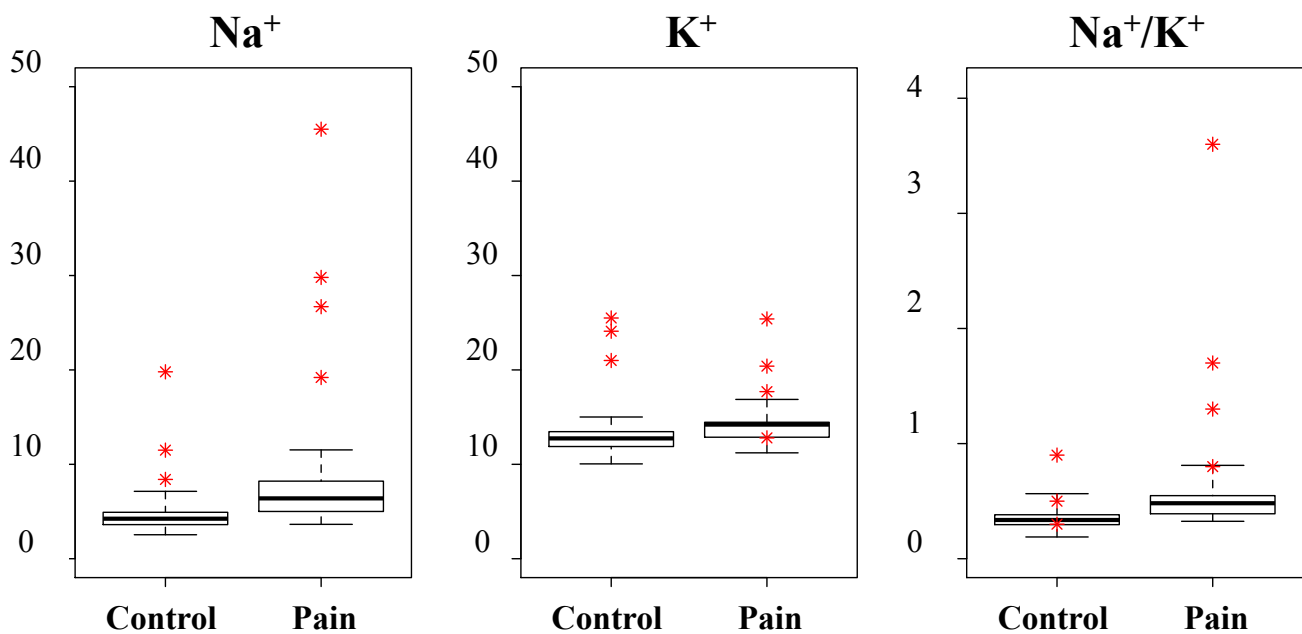

Figure 3.13 Box plots of Na^+ and K^+ concentration and Na^+/K^+ ratio for human milk samples, with individual bovine values.

Box plots illustrating median, quartiles and range.

Human samples are shown in control and pain groups.

Individual bovine samples are represented by red stars (); milk samples retrieved from animals with mastitis are represented as part of the 'pain' category.*

Pooled bovine vat samples are excluded from this figure.

3.5 Metabolomics methods optimisation

Due to the complex nature of human milk and the large variability between individuals it is important to develop methodology that allows the unbiased analysis of as many milk metabolites as are amenable to the analytical technique employed, whilst eliminating any unnecessary preparation steps and reducing the addition of human and experimental error. Therefore, optimisation of a number of experimental conditions was required. These included the temperature of derivitisation and the volume of sample for analysis.

3.5.1 Sample volume optimisation

Optimisation of the sample volume required for analysis was necessary to assess the dynamic range in concentration of the measured metabolites of human milk, and to identify a volume that would not overload the instrument, while still being large enough to detect metabolites present at the lower concentrations.

Human and bovine milk volumes of 25 μl , 50 μl , 75 μl and 100 μl were tested to determine the maximum volume of milk that could be analysed in a single derivatising volume, using the previously described method of preparation. $^{13}\text{C}_6$ sorbitol was added to each sample at the same concentration, regardless of the milk volume being tested. The alkanes were also added at a consistent volume. These internal standards allowed a comparison of the reproducibility (calculated as %RSD) of the measured signal(s) within an increasingly more concentrated sample matrix (namely, 25 μl through to 100 μl equivalent milk volumes).

The relative standard deviation (%RSD) of the $^{13}\text{C}_6$ labelled D-sorbitol was calculated for the sample set (n=5) and pooled QCs for each test volume (Table 7.1). The 50 μl test volume had the highest reproducibility for this internal standard, with a %RSD of 10.56 %. The 75 μl and 100 μl volumes had a reproducibility of 36.32 % and 40.02 % respectively, much higher than the 30% RSD which is commonly deemed acceptable for biological samples (Dunn et al., 2011; Edmands, Barupal and Scalbert, 2014) and less than the 20 % RSD deemed acceptable by the Food and Drugs Administration guidelines for biomarker studies (Kirwan, Broadhurst, Davidson & Viant, 2013). This is likely due to the sample preparation inconsistencies (as noted during preparation) of the 75 μl and 100 μl volumes, many of which appeared opaque and presented with precipitation, which suggests the larger sample volumes were not completely dissolved in the derivatisation solvents at the higher sample concentrations.

To assess if the chosen internal standard, $^{13}\text{C}_6$ -D-sorbitol, would likely be able to account for signal fluctuations across the chromatogram when applied to the greater metabolomics study, the $^{13}\text{C}_6$ -D-sorbitol was compared against the measured signal of the added alkanes. The peak intensity of n-alkanes C_{12} , C_{15} , C_{19} , C_{22} , C_{28} , C_{32} , C_{36} was divided by the corresponding peak area of the internal standard, $^{13}\text{C}_6$ -D-sorbitol. The %RSD of the seven n-alkanes in the test samples were calculated and used to determine reproducibility (Table 3.7). A comparison of the %RSD of the n-alkanes in the four test volumes found that only the 25 μl and 50 μl sample volumes produced a %RSD below the desirable 30 % RSD cut off (Edmands, Barupal and Scalbert, 2014). The 50 μl replicate volumes produced a lower mean %RSD for the normalised n-alkane values than the QC pooled samples of the same volume, however both recorded values below 20 % RSD (Table 3.7). The 25 and 50 μl (equivalent) milk

volumes, therefore resulted in the most reproducible measurements whereby the internal standard would be most effective at correcting sample preparation and/or analytical differences between samples within the greater metabolomics study. A 50 μ l sample volume was used for the subsequent analysis of all study samples.

Table 3.7 %RSD of the area ratios of $^{13}\text{C}_6$ Sorbitol and Alkanes.

Volume (μl)	% RSD ($^{13}\text{C}_6$ - Sorbitol; raw peak area)	% RSD (Alkanes; corrected)						
		C ₁₂ ,	C ₁₅ ,	C ₁₉ ,	C ₂₂ ,	C ₂₈	C ₃₂	C ₃₆
25	12.50	7.12	6.13	6.17	6.15	5.71	5.25	10.12
50	10.56	4.40	6.24	7.53	8.91	12.82	11.79	16.50
QC (50)	20.08	15.25	14.06	12.86	12.04	14.37	15.13	17.13
75	36.62	82.20	81.05	77.91	78.99	88.15	78.91	71.62
100	40.02	59.70	58.84	59.66	59.57	57.87	60.02	61.28

Uncorrected relative standard deviations of $^{13}\text{C}_6$ D-sorbitol, calculated from the raw peak areas.

Relative standard deviations of alkanes normalised to $^{13}\text{C}_6$ labelled D-sorbitol.

The highlighted row indicates the %RSD recorded for the pooled QCs which were 50 μl in volume.

3.5.2 Temperature optimisation

Derivatisation is the chemical modification of an analyte, often used to facilitate gas chromatography. Optimisation of this technique was employed to ensure the samples were as close to complete derivatisation as possible making them amenable to analysis by GC-MS, while reducing the number of derivatives for a single metabolite to achieve optimal signal intensity, and identification of the maximal number of metabolites.

A temperature trial was conducted to determine the optimal temperature for MSTFA derivatisation. To determine the optimal derivatisation temperature for derivatisation, the peak area of each metabolite in a mixture of thirty metabolite reference standards was compared, and the standard deviation between the triplicates at each of the test temperatures calculated. The measured signal intensity (represented by peak area) is important to the analysis and reflective of the effectiveness of the derivatisation, however sample reproducibility (represented as standard deviation) was ultimately the determining factor in identifying the optimal derivatisation temperature. Ideally, a large peak area (high signal intensity) with a low standard deviation (good reproducibility) would indicate the optimal temperature.

The methods for temperature optimisation were based on a derivatisation method by Gummer et al. (2013) using a Thermomixer (TM) for incubation. For comparative purpose two TM control temperatures were analysed, 37°C and 60°C, as previously stated in 2.2.5.1.2 (derivatisation temperature optimisation). The derivatisation of these two TM controls occurred within the microcentrifuge tubes that the metabolite standards were prepared in. This approach was determined less suitable for incubation

at elevated temperatures as it resulted in a greater signal of analytical artefacts (non-biological analytes) leaching from the 2 ml polypropylene tubes.

All of the 30 measured metabolite standards were assessed for reproducibility at the different derivatisation temperatures (Appendix 3.5a-3.4t), however those found most relevant to the final results of this thesis are presented here (Figures 3.14-3.17). L-phenylalanine and L-methionine (Figures 3.14 and 3.16, respectively), demonstrate the least signal reproducibility at the lowest and highest reaction temperatures. The remaining figures are provided in Appendix 3.5a-3.4t. The optimum derivatisation temperature varied amongst the individual reference standards, however 60°C and 75°C generally provided the strongest reproducibility in signal intensity when incubated within the sealed analytical vial, rather than in polypropylene (Figures 3.14-3.17). Figure 3.14 and 3.15 display the peak area and standard deviation for metabolite L-phenylalanine (1 TMS). Figure 3.16 and 3.17 display the peak area and standard deviation of metabolite L-methionine (1 TMS) respectively.

L-phenylalanine (1 TMS) was the least reproducible when derivatised at 90°C and L-methionine (1 TMS) was least reproducible at 37°C. Incubation at 90°C had the lowest reproducibility across the entire metabolite range, followed by 37°C (37°C is the MSTFA derivatisation temperature employed in many current protocols; Francki, Hayton, Gummer, Rawlinson & Trengove, 2015; Gummer et al., 2013).

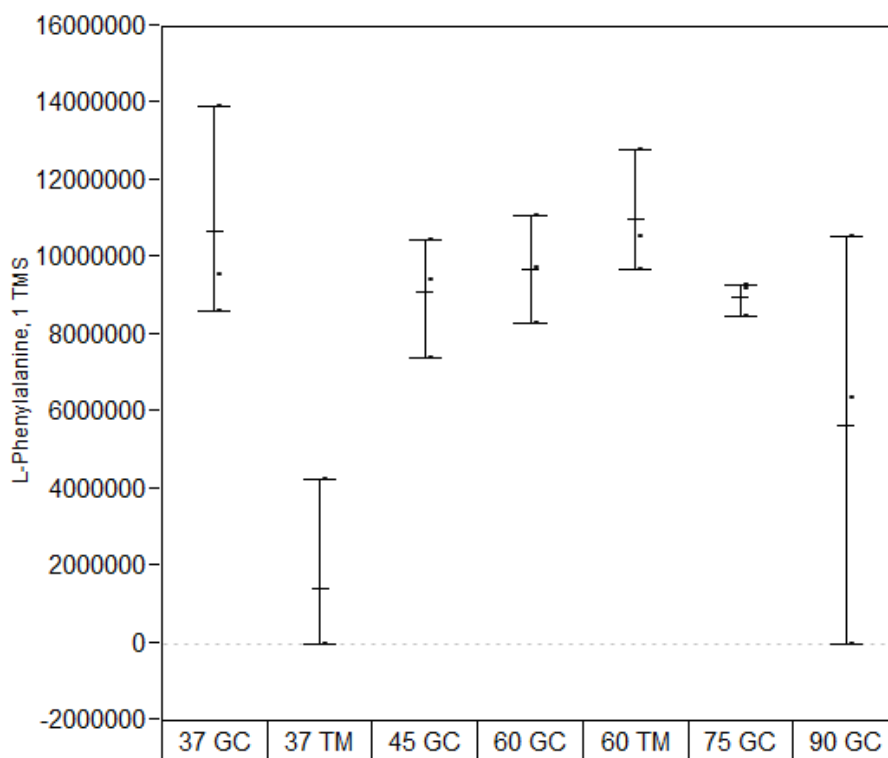

Figure 3.14 Measured Peak area of L-Phenylalanine (1 TMS) using MSTFA incubation temperatures of 37°C, 45°C, 60°C, 75°C, 90°C with the incubation performed in a GC oven (GC) or with agitation in a Thermomixer (TM).

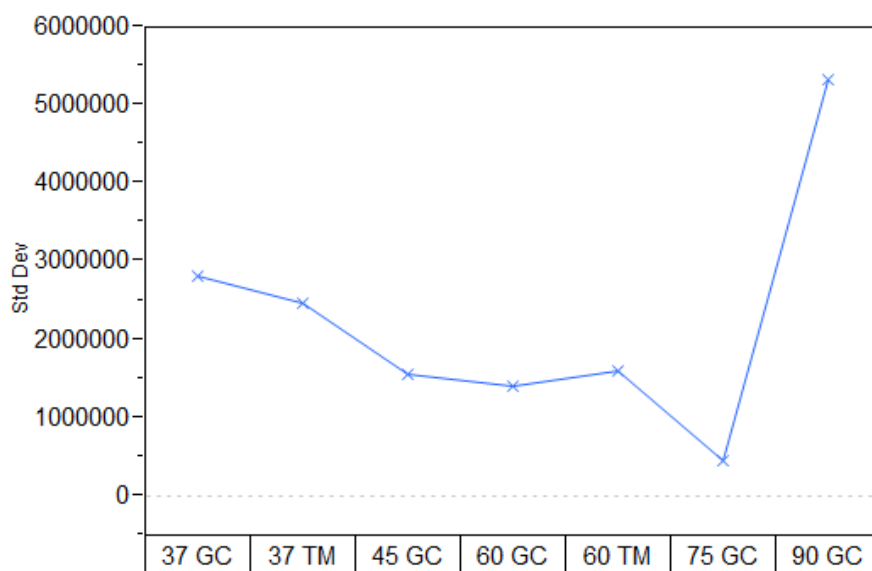

Figure 3.15 Standard deviation of the measured peak area (n=3) of L-Phenylalanine (1 TMS) using MSTFA incubation temperatures of 37°C, 45°C, 60°C, 75°C, 90°C with the incubation performed in a GC oven (GC) or with agitation in a Thermomixer (TM).

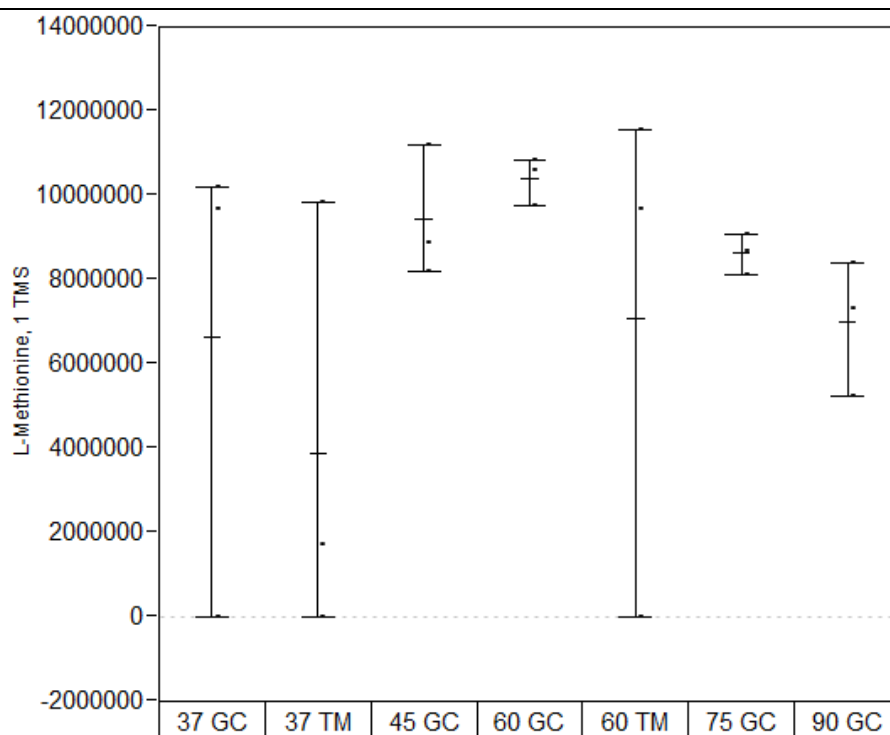

Figure 3.16 Measured peak area of L-Methionine (1 TMS) using MSTFA incubation temperatures of 37°C, 45°C, 60°C, 75°C, 90°C with the incubation performed in a GC oven (GC) or with agitation in a Thermomixer (TM).

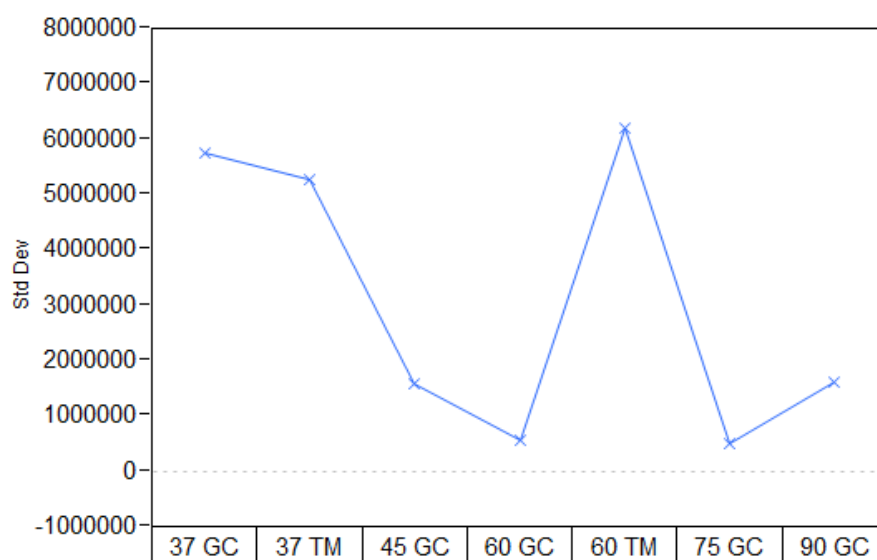

Figure 3.17 Standard deviation of the measured peak area (n=3) of L-Methionine (1 TMS) using MSTFA incubation temperatures of 37°C, 45°C, 60°C, 75°C, 90°C with the incubation performed in a GC oven (GC) or with agitation in a Thermomixer (TM).

The derivatisation temperature with the smallest standard deviation for both L-Phenylalanine (1 TMS) and L-Methionine (1 TMS) and therefore most reproducible for these specific metabolites was 75°C as shown in Figures 3.15 and 3.17 respectively. Across the tested metabolite reference standards 75°C demonstrated the greatest reproducibility between replicates. Where the 75°C incubation temperature wasn't the most reproducible, it still produced high peak intensity and a relatively low standard deviation. Consequently, sample derivatisation was carried out at 75°C in the later metabolomics analyses, in accordance to these findings.

3.6 Changes to the metabolite composition of human milk in response to pain and trauma of the nipple

Untargeted metabolomics analysis was conducted on human milk samples from women experiencing persistent nipple pain (NP) without evidence of nipple trauma (pain subgroup; PG), or with trauma (trauma subgroup; TG) and of women not presenting with nipple discomfort (control group; CG). Milk samples from bovine control and of bovine animals presenting with mastitis were also assessed. A list of metabolites was compiled and relative abundances determined to identify metabolites differing between the TG and PG patient samples, for comparison to CG, and identify those of most interest to this study. The use of QC samples was determined paramount to the data integrity and used to guide the data interpretation. The QC sample was a pooled milk sample containing all 42 milk samples both human and bovine.

The final metabolomics sample set prepared for GC-MS analysis comprised the 42 individual human and bovine milk samples, pooled milk quality controls (QC) and a derivatisation (no milk) control. A series of conditioning solvent blanks were run at the

start of the sequence followed by five QCs, for the purposes of conditioning the instrument prior to milk sample analysis. Following this initial run sequence, milk samples were randomised amongst the QC samples, with one QC analysed before and after every four experimental samples (Figure 3.18).

Preventive instrument maintenance of the GC-MS was required during analysis of the sample set. Due to the composition of the milk samples and non-volatile components adhering to the inlet liner, frequent preventive GC maintenance was required. Maintenance frequency was determined by an observed drop in signal intensity (assessed during the sample sequence), requiring the replacement of inlet consumables and trimming of the guard-column.

Following complete data interrogation, the QC sample results as modelled by PCA indicated that the first 29 injections were comparable, following which the signal intensity was noticeably poorer. Unfortunately data normalisation (to the internal standard) and scaling were unable to correct the signal in the data acquired after this point in the analytical sequence (as seen in the scores plot in Appendix 3.6). Therefore, only the first 29 samples were used for the final data interpretation.

The final data set consisted of the analysis of the pooled QCs (14 replicate preparations), five of which were analysed at the start of the GC-MS analytical sequence (QC01-QC05), followed by one QC preceding every fourth milk sample (which were analysed at random; QCs06-14). The QC samples were modelled by PCA together with the experimental samples, allowing the projected clustering of the QC samples to identify reliable measurement of the samples run amongst them. The

projection of the scores of the first two principal components demonstrated an obvious lack of reproducibility after sample QC_P_29 (Figure, in appendix 3.6). Subsequent analyses could not verify if the compositional differences between samples post QC_P_29 were biological or instrumental, therefore samples following QC_P_29 were not used for the final interpretation.

The final sample set used for the metabolomics comparisons and interpretation included 11 control (CG), one nipple pain without trauma (PG), three nipple pain with trauma (TG), two bovine control (BC), one bovine mastitis (BM), one bovine vat/pooled sample (BV) and 10 QCs (Figure 13.8). Two of the human samples were collected from the same mother (M03/N10), which were a CG and PG milk sample.

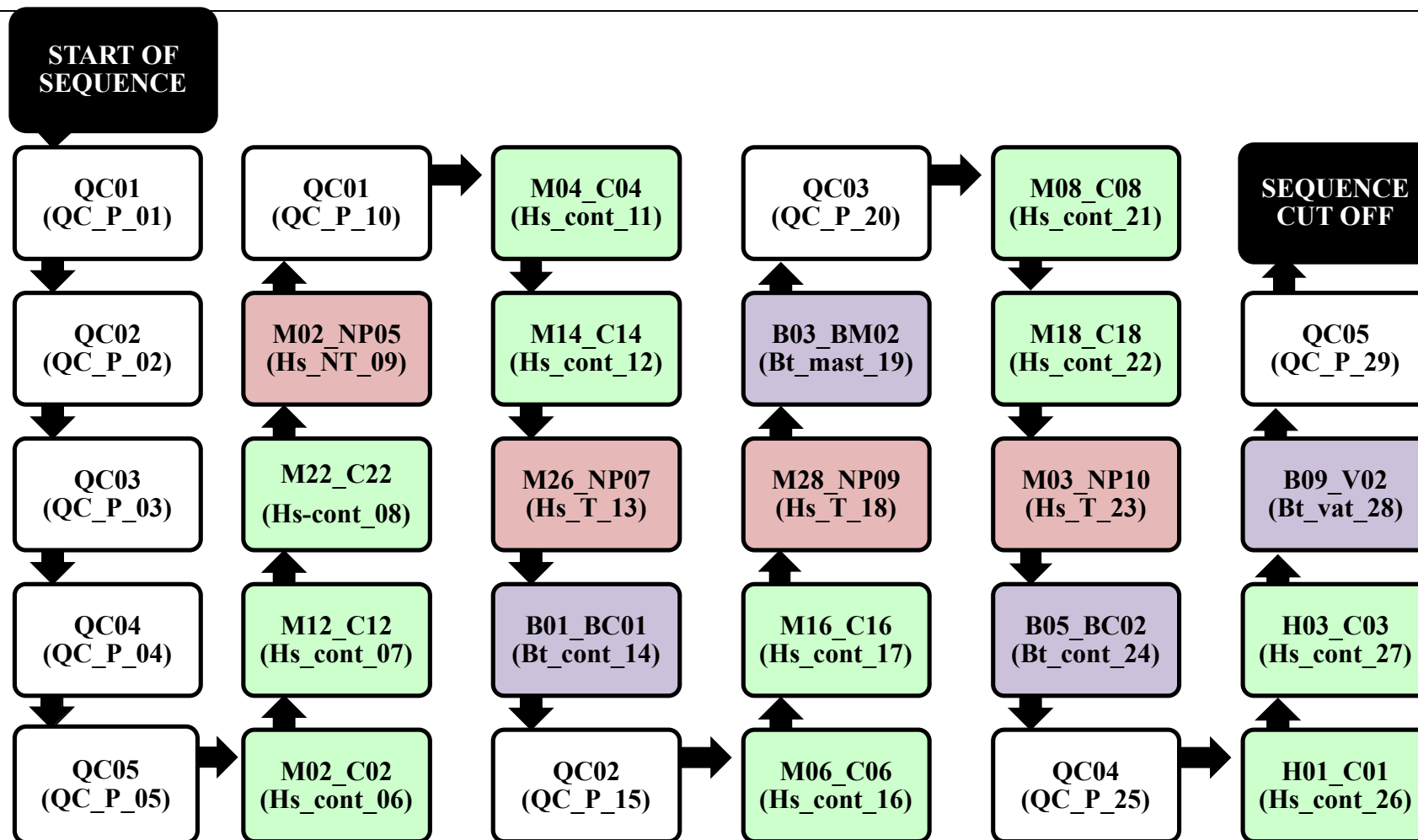

Figure 3.18 Final metabolomic GCMS sequence run order.

Samples are labelled with their sample identification number, i.e. M02_C02 from a human participant who donated a control sample, followed by a sequence run identification label including sample type and position in sequence, i.e. Hs_cont_06 (Hs_cont; human milk, control sample, Hs_T; human milk, nipple pain with trauma sample, Hs_NT; human milk, nipple pain without trauma sample, QC_P; pooled quality control of all milk samples, Bt_cont; bovine milk, control sample, Bt_mast; bovine milk, mastitis sample, Bt_vat; bovine milk, pooled sample collected from storage vat.

Using the previously compiled metabolite library, the final samples were analysed using GCMSsolutions software to compile a list of metabolites and calculated peak areas for each analyte. Analytes measured in the no-sample-control derivatisations were deemed analytical artefacts and removed from the data matrix, as they were found to be of non-biological origin. The remaining features other than those of the added analyte standards were considered metabolites endogenous to the milk samples. The metabolite abundances were interrogated using PCA to model the variance between the human nipple pain group and controls, together with the bovine and pooled QC samples.

A scores plot was used as a visual tool for data mining, where the projected position of each of the samples on the scores plot is a measure the metabolite abundances (metabolome) relative to the metabolite abundances of the other samples on the plot. The PCA scores plot, representing the modelling variance within the data, showed like groupings, indicative of common features of the metabolite profiles. As anticipated, principal component 1 (PC1), which explains 25% of the variance between test groups, demonstrated distinct grouping of human and bovine samples with pooled QCs situated in the middle of the two groups (Figure 3.19).

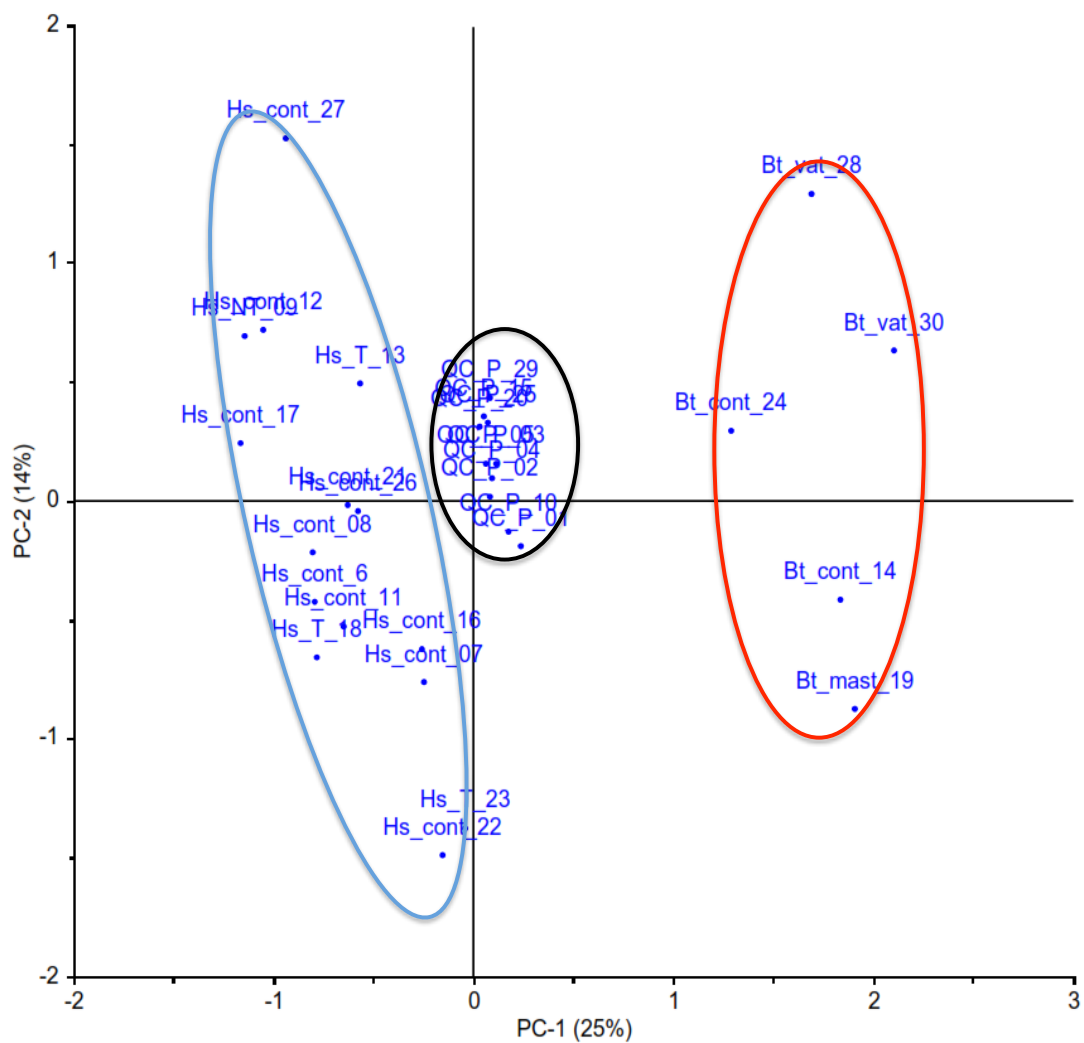

Figure 3.19 Scores plot of PC-1 (25%) vs. PC-2 (14%) for the final sample set. The human milk samples are indicated by the blue circle, pooled QCs by the black circle and bovine milk samples by the red circle (Hs_cont; human milk, control sample, Hs_T; human milk, nipple pain with trauma sample, Hs_NT; human milk, nipple pain without trauma sample, QC_P; pooled quality control of all milk samples, Bt_cont; bovine milk, control sample, Bt_mast; bovine milk, mastitis sample, Bt_vat; bovine milk, pooled sample collected from storage vat).

Samples found towards the centre of the axis indicate samples that have little influence on the data model; in this instance the central samples are the pooled QCs as they're an average of the two sample sets. The samples projected with the most extreme coordinates are the most influential in the data set relevant to principal components of the scores plot. Therefore, it can be seen that there were markedly different groupings for the human samples (blue circle) compared to the bovine samples (red circle), on Figure 3.19.

Human milk samples were further analysed independent of the bovine samples and plotted using PCA to determine any compositional variations in milk between control mothers and those presenting with nipple pain. When plotted, the first three principal components showed little significant grouping of test groups. However, principal component 4 (PC4), associated with 8 % of the variance between human milk samples, (red circles) demonstrated tentative grouping of the control and nipple pain samples indicating possible metabolite differences consistent with the trauma state between the two subgroups (Figure 3.20). Two samples collected from a single mother (one control: Hs_cont_11 and one nipple pain: Hs_NT_09) are outlined by a black square. This mother was experiencing unilateral nipple pain without evidence of trauma; the similarity in metabolite composition between the two samples may indicate the low severity of her condition. This result also supports that the modelled data reflects changes to the milk composition arising out of a trauma event, rather than nipple pain presenting without trauma.

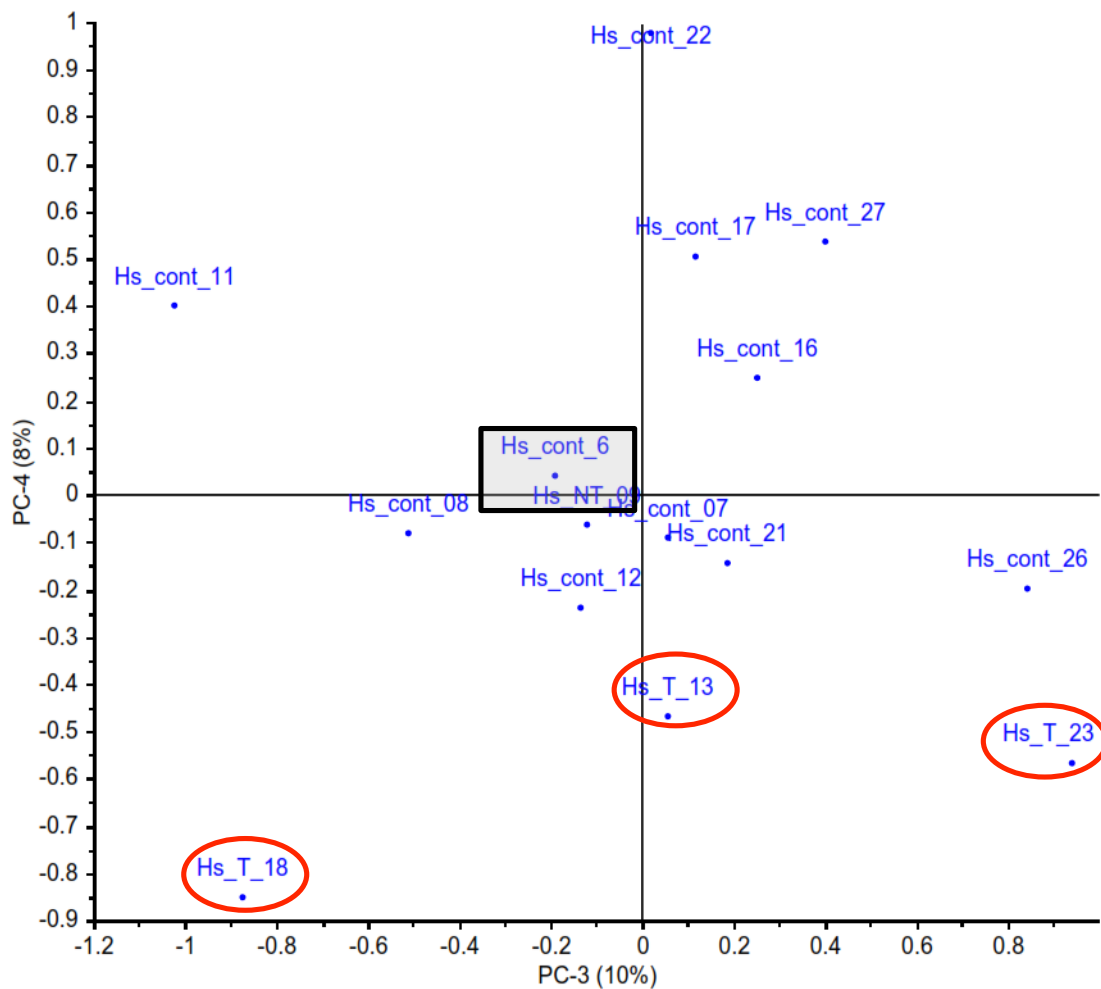

Figure 3.20 Score plot of PC-3 (10%) vs. PC-4 (8%) for human milk samples. Red circles indicate nipple pain with trauma samples and the black square encloses the two samples that were retrieved from the same mother, M03/NP10) (*Hs_cont*; human milk, control sample, *Hs_T*; human milk, nipple pain with trauma sample, *Hs_NT*; human milk, nipple pain without trauma sample).

A loadings plot is used to visualise the influence of individual metabolites relative to the modelled Scores projection. The metabolite position on the loadings plot indicates its loadings value and explains its individual influence on the projected component model. Metabolites of the most extreme values have the greatest leverage on the sample groups as projected on the scores plot. Consistent with the Scores projection (Figure 3.20), the metabolites with the most extreme PC4 coordinates have the greatest influence on the observed differences between trauma and no trauma groups. The metabolites with the lowest PC4 axis coordinates (negative values) are the metabolites most heavily associated with milk from mothers of the trauma category (TG) (Figure 3.21).

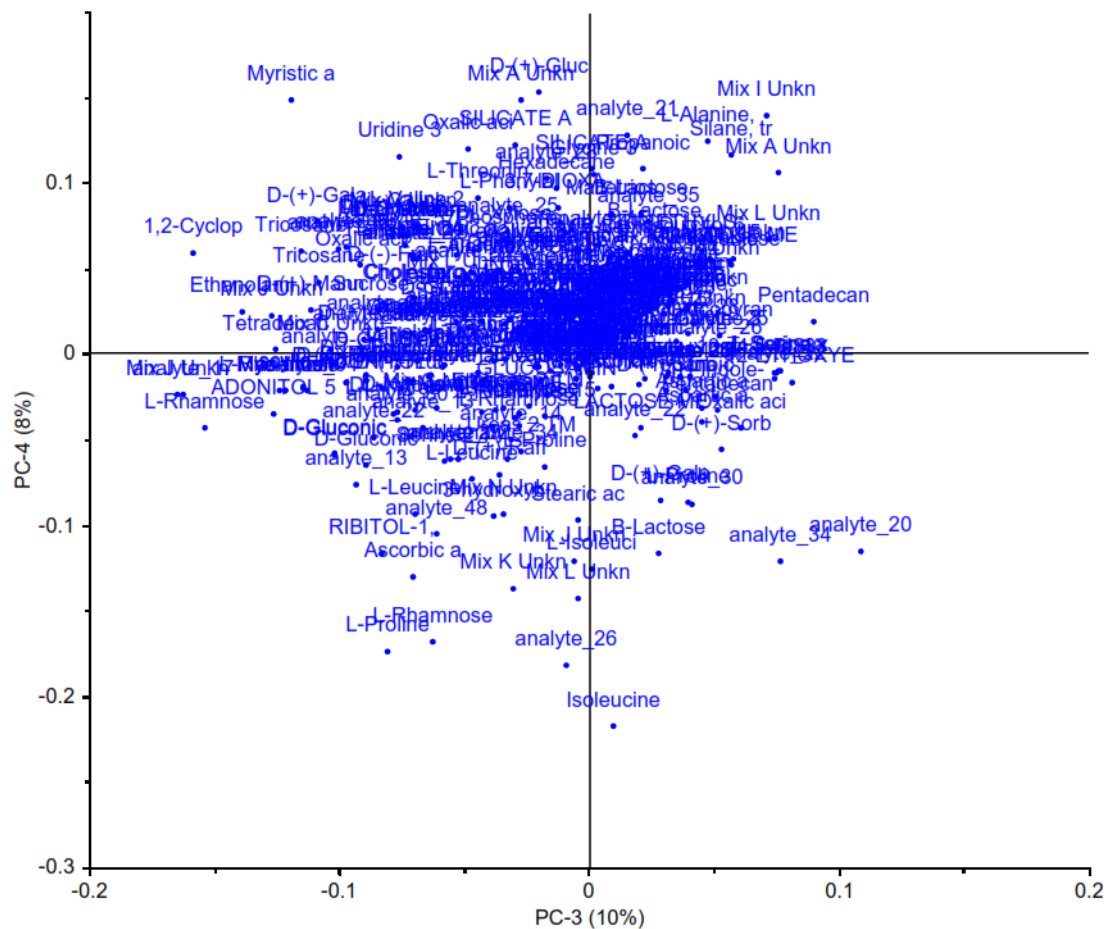

Figure 3.21 Loadings plot of PC-3 (10%) vs. PC-4 (8%) for human milk metabolites.

To further investigate the metabolites contributing to the projection of PC4 (found to model differences between CG and TG samples) the correlation loadings of each metabolite was calculated from the PCA loadings. This was to identify metabolites most reliably contributing to the variance (Figure 3.22). The correlation loading is the correlation between the scores and the actual observed data. The outer ellipse on the correlation loadings plot indicates 100% of explained variance and the inner ellipse indicates 50% of explained variance (Figure 3.22). The metabolites in the radius between the ellipses are more discriminating for the sample set being analysed.

A list of the most influential metabolites based on their correlation loadings (explained within 50-100% of the model) was constructed, as shown in Table 3.8. Metabolites listed at the top half of the table indicate metabolites that are positively correlated with the trauma category and have been identified to explain the variance between TG and CG samples. Metabolites listed towards the bottom of the table indicate metabolites positively correlated with control samples as they are found more frequently and in larger volumes in control samples than in nipple pain samples. Together the list of metabolites describes the most influential changes in milk composition between the CG and TG samples.

The metabolites that displayed strong positive correlation with the TG samples in PC4 include Isoleucine 1TMS (-0.79), Unknown_29.43_1874_281 (tentative, analyte 116) (-0.68), L-isoleucine 2TMS (-0.63), L-proline 2TMS (-0.62) and D-(+)-galactose MEOX 29.94 1880 (-0.60) (Table 3.8).

Metabolites strongly correlated with the CG samples include Unknown_31.54_1971_218 (0.71) and Uridine 3TMS, 38.98, 2462 (0.70) (Table 3.8).

Table 3.8 Correlation loadings plot metabolite IDs, and axis coordinates, associated with nipple pain and control sample groups.

Sample grouping	PC4 axis coordinate	Data matrix ID	Library Match
Nipple pain (TG)	-0.79	Isoleucine 1TMS_14.47_1186_86	In house library
	-0.68	Unknown_29.43_1874_281	-
	-0.63	L-Isoleucine 2TMS	Wiley
	-0.62	L-Proline 2TMS	Wiley
	-0.60	D-(+)-Galactose 5TMS MEOX_29.94_1880_319	In house library
	-0.59	Unknown_42.99_2721_204	In house library
	-0.59	L-Proline xTMS, 24.06, 1585_	In house library
	-0.59	L-Proline x TMS_24.06_585_142	In house library
	-0.58	Ascorbic acid, x TMS 29.67	Wiley
	-0.55	Unknown_21.95_1484_233	In house library
	-0.53	B-Lactose 8TMS, 42.26	Wiley
	-0.53	L-Methionine, 1 TMS_20.27_1416_104	In house library
	-0.52	3-Hydroxybutyric acid, 2 TMS_13.87_1157_86	In house library
	-0.51	Stearic acid 1TMS	Wiley
Control (CG)	0.50	Unknown_31.54_1971_218	In house library
	0.52	Myristic acid 1TMS_29.3_1850_131	In house library
	0.52	Propanoic acid, 2,3-bis(TMS)oxy) TMS ester	Wiley
	0.55	Unknown_24.98_1633_192	-
	0.60	Silicate	Wiley
	0.64	L-Alanine xTMS_1894_1361	In house library
	0.65	D-(+)-Glucose 5 TMS , MEOX_30.38_1924_130	In house library
	0.65	Silane, trimethyl(1-methyl-1-phenylethoxy)	Wiley
	0.65	Oxalic acid 2TMS_13.13_1125_221	In house library
	0.66	Glycine 3TMS_17.63_1308	In house library
	0.70	Uridine 3TMS_38.98_2462_217	In house library
0.71	Unknown_31.54_1971_218	In house library	

4 Discussion

Breast milk is the preferred source of nutrition for the developing infant, with breastfeeding linked to many health, nutritional, immunological, developmental, psychological, social, economic, and environmental benefits (Anatolitou, 2012). Nipple pain and mastitis during the first three weeks of breastfeeding are important clinical factors associated with early cessation of breastfeeding (Schwartz et al., 2002). The intensity and duration of maternal nipple pain during breastfeeding have been correlated to interference with breastfeeding and general quality of life (McClellan et al., 2012). Women who experience pain in the first three weeks postpartum are also more likely to give up breastfeeding than women who experience pain after the first three weeks (Schwartz et al., 2002), thus jeopardising both their own and their infants short and long term health. Rapid identification and treatment of these conditions would potentially reduce premature weaning and extend breastfeeding duration. Despite initiation of breastfeeding increasing in Perth (90-96% on discharge from hospital), the prevalence of breastfeeding at 6 (50-60%) and 12 months (22-28%) are still below the national targets of 80% and 40%, respectively (Scott et al, 2006; NHRMC, 2010).

A recent Australian study recorded the incidence of nipple pain in 360 breastfeeding women who intended to breastfeed beyond 8 weeks postpartum (Buck, Amir, Cullinane & Donath, 2014). They found that 79% of women reported nipple pain in the first week post partum and 58% experienced nipple damage, including cracked or grazed nipples (Buck et al., 2014). The prevalence of nipple pain and nipple trauma had at best reduced by half at 4 weeks post partum (43% and 24%, respectively) with

a further decline identified at 8 weeks post partum where 20% reported nipple pain and 8% reported nipple damage (Buck et al., 2014). In this study 20 women ceased breastfeeding before the end of the study (>8 weeks) as a result of developing nipple pain and trauma (Buck et al., 2014).

Despite the highest incidence of nipple pain identified in early lactation, women in the first four weeks of lactation were deemed not acceptable for this study. This study aimed to identify compositional changes in breast milk associated with nipple pain and trauma. However, the composition of milk undergoes many changes over the first three weeks post parturition until it reaches the mature phase which is maintained for the remainder of lactation (Hassiotou & Geddes, 2013). Therefore, the composition of milk is too variable in the initial stage of lactation to enable identification of changes resulting from breast pathology compared to transitional changes of the milk to mature milk. For this reason participants in this study were recruited between 1-6 months post parturition to eliminate compositional changes in the milk due to the establishment of lactation, thereby identifying only those changes associated with breast pathology.

The primary aim of this study was to determine compositional changes to human milk, consequential to mothers experiencing persistent nipple pain with and without evidence of trauma. It was hypothesized that the presence of nipple pain in lactating women would result in changes in the human milk metabolite profile possibly due to infection and/or inflammation of the breast, compared to asymptomatic women. A series of bovine samples from asymptomatic cows and cows presenting with mastitis served as comparative controls.

The treatment for inflammatory symptoms of the breast, including nipple pain and mastitis, has been under discussion for some time. This is largely due to the wide spectrum of symptoms under the umbrella of ‘mastitis’, the myriad of potential causes, and lack of international scale for the measurement of symptoms (Kvist, Larsson, Hall-Lord, Steen & Schalen, 2008).

McClellan et al. (2012) investigated a selection of pain scales as objective measures to compare the pain experienced by breastfeeding women. Differences in pain scale were reported for women with nipple pain with and without evidence of trauma. Pain scores reported for the mothers in the nipple pain with trauma group were significantly higher than the nipple pain without trauma group ($p < 0.001$). Mothers experiencing nipple pain with trauma described their pain as ‘piercing’ ‘tight’ and ‘tearing’, whereas mothers in the nipple pain without trauma group most commonly referred to their pain as ‘radiating’. In this study participants’ pain was converted to a numerical value between 0-10; zero being no pain and 10 being the worst perceived pain possible. Participants in the control group all reported their pain to be 0, participants in the nipple pain group reported perceived pain levels between 4 to 10. The mean pain level was reported for the nipple pain without evidence of trauma was 5.83 with one participant reporting pain as high as 8; however this was not different to the TG subgroup with a mean pain score of 5.2. Compared to McClellan et al. (2012) the trauma group was not reporting as much pain and therefore may not have been as advanced in the mastitis continuum.

The influence of bacteria in the development of nipple pain and nipple trauma is still not clear. Within the literature there are several studies surrounding the identification and quantification of pathogenic bacterial species in an attempt to determine the

causative agents of nipple pain and mastitis. Kvist et al. (2008) conducted a bacterial study (using PCR) to determine the role of bacteria in nipple pain and mastitis and found five main bacterial species to be the most prevalent between control and case samples; coagulase negative Staphylococci (CNS), viridans streptococci, *Staphylococcus aureus* (*S. aureus*), Group B streptococci (GBS) and *Enterococcus faecalis*. Despite this, viridans streptococci (OR: 1.43; p=0.04), *S. aureus* (OR: 1.81; p=0.001) and GBS (OR: 2.40; p<0.001) were found significantly more often in case samples than control. Additionally, CNS were detected significantly more often in the milk of healthy control mothers (90%) than in those suffering from mastitis (83%) (OR: 0.60; p=0.02) (Kvist et al., 2008). In this thesis study, CNS were found in 94% of human milk samples and 100% of human control samples. CNS was found in highest abundance in the human control samples (1,231 CFU/ml) compared to the nipple pain samples (370 CFU/ml). Kvist et al. (2008) concluded that CNS was an important bacterium in the protection against pathogens, and increasing bacterial counts did not influence the clinical manifestation of mastitis. Furthermore, a *S. aureus* study by Heikkila and Saris (2003) found that the commensal bacteria in breast milk might inhibit the growth of *S. aureus* and prevent maternal breast infections, which could explain the higher abundances in control milk samples.

The study of 346 mothers by Amir et al. (2013) using PCR found that *S. aureus* was found in 82% of women presenting with nipple pain and in 79% of women without symptoms of nipple pain or mastitis. Conversely, a microbial culture study by Rowan et al. (2008) looking at the potential of *S. aureus* as a causative agent in nipple pain and trauma found no *S. aureus* in their control group. Furthermore, Rowan et al. (2008) identified *S. aureus* in 38% of mothers with nipple pain with minimal trauma and no obvious infection and in 100% of the mothers presenting with nipple pain with

obvious nipple trauma and infection. The data presented in this thesis identified no *S. aureus* in the control group samples. *S. aureus* was positively identified in only one nipple pain sample out of a total eleven nipple pain samples. This sample was collected from a mother suffering from unilateral nipple pain (PG) and had 82% *S. aureus* growth (620 CFU/ml) in milk from her affected breast, with no *S. aureus* identified in the milk collected from her unaffected (control) breast. However, this was the sample from a mother with nipple pain where *S. aureus* growth was identified, suggesting that in this study nipple pain was not always the result of *S. aureus* infection.

It should be noted that traditional microbial culture is not always a clear representation of the microbial flora of a sample, as culture dominant species can overgrow or inhibit the growth of other species, not all species are amenable to any one method of culture, or at all. Microorganisms isolated using standard culture techniques are rarely the dominant and/or functionally significant species in the communities from which they were obtained (Hugenholtz, 2002).

The study by Amir et al. (2013) found a statistically significant association between the presence of *Candida ssp.* and nipple pain symptoms presenting 2-8 weeks post partum ($p=0.014$). A PCR analysis of the milk of 346 lactating women found that 33% of women were positive for *Candida ssp.*, distinctly different from the 5% of milk samples from the same sample set that cultured positive for *Candida ssp.* (Amir et al., 2013). Furthermore, control samples that tested positive for *Candida ssp.* at any point were 87% more likely to develop nipple pain symptoms than mothers who tested negative for *Candida ssp.* (Amir et al., 2013).

A study by Hale et al. (2009) using microbial culture and a β -glucan assay (where β -glucan concentration 80 pg/mL is considered a presumptive measure of *Candida* infection) found that β -glucan was more commonly found in higher concentrations in control samples than in symptomatic patients, although no control samples and one symptomatic sample cultured positive for *Candida* (1 CFU/15 μ L of milk). Hale et al (2009) suggested that their results were the product of the extreme clean-catch technique used for milk collection (which formed the basis for the collection method used in this study) and that studies that draw conclusions on *Candida* mastitis or the role of *Candida* in nipple pain may be the result of insufficient aseptic techniques and evidence of microbial contamination through the infant's saliva on unsterilised nipples. Amir et al. (2013) suggested that the Hale et al. study (2009) may indicate alternative causes of breast and nipple pain, including mechanical causes such as infant tongue tie or bacterial infection.

A protocol similar to that of Hale et al. (2009) was used for milk collection in this study to ensure microbial contamination of the milk, from skin flora or environmental contaminants, did not influence the microbial composition of the milk. No fungal species were isolated from the human samples, with nipple pain or otherwise, in this study. Yeast species were isolated from bovine milk from both pooled vat samples collected from a single storage vat (BV01 and BV02), but not from individual bovine milk samples. The ability to culture yeast in pooled bovine samples showed that Sabouraud agar was a suitable medium for the isolation of fungal species, with evidence of only fungal species isolated by these means. Furthermore, these results indicate that there were no fungal species in the human samples. Molecular techniques (PCR or sequencing) would be required to confirm definitively that no

fungal species were present in the human milk samples, or identify species non-amenable to this culture technique.

Biochemically it is possible to detect changes in certain macronutrients and micronutrients in breast milk that are associated with closure of the tight junctions between the lactocytes at the onset of secretory activation (Pang and Hartmann, 2007). A study by Fetherston, Lai and Hartmann (2006) found that mastitis was associated with the reopening of the tight junctions and consequently paracellular pathways, accompanied by increased breast permeability, inflammation of the breast, and reduced milk synthesis. A significant increase in Na⁺ concentration was observed in women with nipple trauma ($p < 0.004$), and a further increase in mean Na⁺ concentration was observed in women with clinical mastitis (21.8 mmol/L) (Fetherston et al., 2006). In this thesis, a significant difference in Na⁺ concentration was observed between mothers in the control and TG groups ($p < 0.001$). However, the mean Na⁺ concentration for the TG subgroup (8.04 ± 2.40 mM) was much lower than that observed in women with mastitis in the Fetherston et al. study (2006), indicating that no participant in the study had mastitis, but possibly had the potential to develop into mastitis if left untreated.

The composition of milk is highly variable over the course of lactation, between feeds and between mothers (Chung, 2014) and can be influenced by maternal and infant health and medication use (McManaman & Neville, 2003). Paracellular pathways allow the direct exchange of interstitial or serum substances into the milk. This transport pathway closes during the initiation of lactation, due to the reduction of tight junctions between the epithelial cells (McManaman & Neville, 2003). This pathway is affected by the physiological state of the breast, and during an episode of

inflammation or mastitis, tight junctions between the epithelial cells can become compromised, allowing plasma components such as sodium and calcium to leak into the milk (Shennan & Peaker, 2000).

Assessment of the increased permeability of the paracellular pathway can be determined by measuring the solute content of the milk, in particular Na^+ and K^+ (Shennan & Peaker, 2000). Damage to the paracellular pathway can be identified by an increase in Na^+ concentration and decrease in K^+ concentration. However, measurement of the Na^+/K^+ ratio has been proposed as a more accurate indicator as it reduces the influence of individual differences due to the large variation in human milk composition between individuals. Areetey et al. (2008) proposed an elevated Na^+/K^+ ratio above 1.0 to be considered indicative of infection.

No individual in this study recorded a Na^+/K^+ ratio above one. The highest ratio was 0.811 recorded from the milk of a mother experiencing persistent nipple pain with trauma. The TG subgroup had a significantly higher ratio than the control group ($p < 0.001$) and a mean ratio difference of 0.13 between the TG and PG nipple pain subgroups indicating, alike the pain scores, little difference between the groups.

Sodium and potassium analysis has been found to be a useful tool in relation to mastitis, however it appears less conclusive in the analysis of nipple pain. Mastitis can cause a significant amount of damage to mammary tissue, resulting in considerable alteration in milk composition. As nipple pain without incidence of mastitis is often less invasive, it is possible that the damage to the mammary tissue was not extensive enough to result in a significant increase in Na^+/K^+ concentration or ratio in this study.

All analyses of sodium and potassium concentrations presented here should be treated with caution, as the sample size can be considered too small to draw definitive conclusions. This is due to the pre-expected marginal differences between the groups due to the subtleties of the pain condition. To detect a true difference in Na^+/K^+ ratio between nipple pain samples in TG and PG subgroups, a larger sample size would be required. Using the independent nipple pain samples from this study, a t-test power calculator was used to determine the sample size required to improve the power of the study to 80 and 90% (Lenth, 2009). The two-sample group t-test found that an increase in sample size to 20 participants per group would be required to increase the power of the study to 80% and 26 participants per group would increase the power of the study to 90% (Lenth, 2009). It is assumed that each participant would be included in only one group, and that only one sample would be taken from each. If more samples were taken, or another study design was used, then smaller numbers might be appropriate.

The burgeoning area of metabolomics as a diagnostic medium has begun to be explored in the dairy industry. A metabolomics study by Sundekilde et al. (2013) identified a series of metabolite biomarkers including isoleucine, lactate, butyrate and acetate to be linked with an elevated somatic cell count in bovine milk, which is indicative of mastitis. Sundekilde et al. (2013) proposed that the detection of these biomarkers could be used to determine milk quality, diagnose mastitis and to determine the level of infection. The same concept could be applied to human milk: determining changes to metabolites as a means of diagnosis for breast complications. Metabolite profiling has the potential to illuminate how the presence of infection and inflammation affects breast milk composition, leading to a greater understanding of the effect of nipple pain and mastitis on the lactating breast and providing a means of

monitoring treatment. As nipple pain is often a precursor to mastitis, it is important to understand if underlying breast pathology exists. Consequently, if the severity of nipple trauma is associated with underlying infection, then profiling the metabolome of expressed milk will identify any differences in metabolite composition between mothers experiencing varying degrees of pain and discomfort.

Although there have been some studies that associate certain species of bacteria with incidences of nipple pain and mastitis, there is still no reliable diagnostic biomarker of pain or infection to enable rapid effective treatment. Metabolomics is widely used as a functional tool in biomarker detection and systems biology. Metabolomics involves the unbiased quantitative and/or qualitative analysis of the complete set of metabolites present in a biological system. Biostatistics plays an essential role in analysing differences in metabolomes and enabling the identification of metabolites pertinent to a particular phenotypic characteristic (Koek, Jellema, van der Greef, Tas & Hankemeier, 2011).

Generally a non-targeted metabolomics approach is used to gain new insights and a better understanding of the biological functioning of a cell or organism in an attempt to interpret biological outcomes (Koek et al., 2011). It is crucial that all steps of the analytical method, namely sample preparation, data acquisition and data processing, are addressed when determining a suitable experimental design. Optimisation, validation and quality control of analytical methods are of the highest importance (Koek et al., 2011).

Optimisation of sample preparation, namely sample volume, was important to identify the dynamic range in metabolite concentrations that would allow the unbiased

measurement of sample components for any given instrumental analysis. The optimisation of the sample loading on the GC was required to determine an amount/mass of metabolite extract that would not overload the instrument while still being large enough to identify metabolites present at low abundance. Milk sample volumes of 25 μl , 50 μl , 75 μl and 100 μl were analysed with the addition of an internal standard ($^{13}\text{C}_6$ labelled D-sorbitol) to determine reproducibility and to assess the capacity for this internal standard to reliably correct for changes in signal intensity across data from GC-MS acquisition.

Extraction and derivatisation efficiency can be estimated using labeled n-alkanes as reference compounds and comparing their response to the response of derivatised metabolites (Koek, Muilwijk, van der Werf, & Hankemeier, 2006). In this instance we sought to assess the reproducibility of the peak intensity of a series of n-alkane analytical standards (C_{12} , C_{15} , C_{19} , C_{22} , C_{28} , C_{32} , C_{36}) added to derivatised milk extracts of differing concentration and the capacity for the corresponding peak area of the internal standard, $^{13}\text{C}_6$ labelled D-sorbitol, to correct for differences in analytical reproducibility among a sample set. The %RSD of the alkanes was used to determine the reproducibility of the four test volumes. Food and Drug Administration guidelines (FDA) for biomarker studies specify a RSD of < 20% to be an acceptable level of precision (Kirwan et al., 2013). The dried 50 μl milk volume metabolite extract was the largest sample volume that could be dissolved in a single derivatising volume while maintaining reproducibility of the added compounds (alkanes) below a %RSD of 30. Larger sample volumes may be compromised due to inadequate amounts of TMS reagent for complete derivatisation, a factor of milk being a complex biological matrix, as well as potential interference with deconvolution and therefore accuracy in measurement of peak areas. In order to not compromise the measurement of the

lower abundant metabolites, the largest reproducible volume, 50 μ l, was used for subsequent metabolomics analyses.

Many metabolites contain polar functional groups, and are thermally unstable at the temperatures required for injection into a GC or are simply not volatile. Derivatisation prior to GC analysis is often needed to extend the application range of GC based methods (Koek et al., 2011). The majority of GC-based metabolomics methods are based on derivatisation using an oximation reagent followed by silylation (often by MSTFA), or solely silylation (Gullberg et al., 2004; Jonnson et al., 2006; Zhang, Wang, Du, Zhu & A, 2007).

Koek et al. (2006) tested several derivatisation reagents including BSTFA, MSTFA, MSTFA with 1% TMCS, BSA, TMSI and TMSI/BSA/TMCS 3:3:2, and found the highest recoveries and smallest RSDs were found using MSTFA. Within the literature a range of derivatisation temperatures has been tested. Gullberg et al. (2004) trialled MSTFA derivatisation at 20°C, 40°C and 60°C and found that 60°C was the optimal temperature. Dunn et al. (2011) used rapid derivatisation at 80°C. Gummer et al. (2013) used 37 °C for MSTFA derivatisation. Bressanello et al. (2014) incubated at 100°C following the addition of MSTFA.

For this study a range of derivatisation temperatures were assessed to determine the optimal derivatisation temperature. Samples were prepared using methoxymation followed by MSTFA derivatisation incubated at 37°C, 45°C, 60°C, 75°C and 90°C. Depending on the target metabolites, different analytical approaches are required and different requirements are posed on analytical performance, including detection limits, accuracy of compound identification and reproducibility (Koek et al., 2011). In

this instance, reproducibility is of the utmost importance due the already highly variability of human milk composition between individuals.

Analysis of the tested derivatisation temperatures found that incubation at 75 °C resulted in high signal intensity, but more importantly the highest reproducibility (determined by comparison of standard deviation across the three replicates for each of the test temperatures). The reliability and suitability of sample preparation, data acquisition, data preprocessing and data analysis are imperative for accurate biological interpretation (Koek at al., 2011).

Metabolomics revolves around the central concept that an individual's metabolic state is a close representation of his/her current physiological state (Fanos et al., 2012).

Analysis of an individual's metabolome is indicative of their current health and disease status (Fanos et al., 2012). Here, we used a metabolomics analysis of human milk from control mothers, and mothers experiencing persistent nipple pain with or without evidence of trauma, to identify metabolite difference reflective of underlying physiological breast health.

Due to the large variation in breast milk composition between individuals, irrespective of their health status, it was important to ensure appropriate quality controls and internal standards were used in the metabolomics analysis to account for noise within the data and identify true biological variation between the control and nipple pain subgroups. Using only a single internal standard for purpose of normalisation can also be presumptuous in that it assumes that all metabolites in a sample are subject to the same amount of unwanted or external variation, often failing to remove unwanted factors (De Livera et al., 2012). In this case a labelled internal

standard, $^{13}\text{C}_6$ labelled D-sorbitol, with the addition of pooled QCs, a mixture of the entire sample set under study, were used to normalise and interrogate the data. A labelled or synthetic internal standard prevents variation resulting from chemical properties and confusion of the internal standard with metabolites of interest that may co-elute or appear similar in structure (De Livera et al., 2012). The use of multiple internal standards or similar, the use of pooled QCs for example, has been found to be more effective at removing unwanted instrumental interference and leads to lower variability of the normalised metabolite abundances (De Livera et al., 2012).

Normalisation allows the reduction of variation or interference between sample extraction efficiency and instrumentation. Resulting values can then be scaled to the median intensity (as opposed to mean; which has been found to be less effective) for each metabolite across the data set (Veselkov et al., 2011). The data manipulation employed in this thesis was to reduce the influence of the highest abundant metabolites within the model by reducing the range of dynamic abundance and therefore the bias within the raw data. A log scaling approach was also used as an additional level of scaling for data modelling (Veselkov et al., 2011). Additionally within this thesis, PCA was used for quality control purposes and initially focused on the pooled milk (quality control) samples, which were run at regular intervals between samples throughout data acquisition.

It is known that the first few injections of samples on the instrument show variability and give unrepresentative results within metabolomics analyses due to small changes in signal intensity and retention time (Veselkov et al., 2011). For this reason, the column was 'conditioned' using five injections of the same biological matrix as the sample set, in this case pooled QC samples, to reduce this initial variability between sample replicates.

The ion source of the MS can become contaminated, especially when using metabolite dense biological matrices such as human and bovine milk, resulting in a gradual decline in instrument sensitivity over time (Veselkov et al., 2011). A slow degradation of signal intensity was observed over the duration of analysis within this study despite preventive cleaning of the ion source and regular monitoring and maintenance of GC consumables. Internal standards and QCs were unable to correct for instrumental error and decline in signal intensity. This indicated that the observed decline in signal intensity was not uniform across the chromatogram and could unlikely be corrected. As a consequence any samples analysed within the analytical sequence amongst the QC samples that failed to group by PCA were determined as not meeting the requirements of the quality control and were excluded from the final interpretation.

Within the sample data, the PCA showed that the first three principal components exhibited little significant grouping of the human nipple pain groups. PC-4, associated with 8% of the variance between the human milk and samples, best showed difference in metabolite composition between the control and trauma samples. Whilst ideally the first components of a PCA would distinguish sample groupings consistent with the study design, the result of finding PC4 of most relevance was not entirely unexpected due to the subtlety of the condition under study (nipple pain) as demonstrated throughout this thesis, such as in the Na^+/K^+ results, and the inherent variation in milk composition between individuals and within individuals over time (Grote et al., 2015).

The projected position of each of the samples on the scores plot (Figure 3.19) is a measure of their individual metabolite abundances relative to the metabolite abundances of the other samples on the plot. Samples found close to each other on the scores plot indicate high positive correlation. This can be seen with Hs_cont_6 (C02) and Hs_NT_09 (NP05), which are closer to each other on the scores plot than other samples, indicated by the black square in Figure 3.19. These samples were retrieved from a single mother (M03) who donated both a control and nipple pain sample. The mother was suffering from unilateral nipple pain with no evidence of trauma and had a Na^+/K^+ ratio of 0.54 (where a ratio above 1 is considered indicative of infection) with no evidence of pathogenic bacteria in her milk, it is therefore consistent that these samples are compositionally similar. In contrast, samples located in diagonally opposite quadrants have a tendency to be negatively correlated, indicating a compositional difference between nipple pain with trauma samples (Hs_T_13, Hs_T_18 and Hs_T_23) located at the bottom of the scores plot, with a negative PC-4 score coordinate, and the control samples present in the opposite quadrants, with a positive PC-4 score coordinate (Figure 7.7). Additionally, the trauma samples recorded the highest Na^+/K^+ ratio; of note was sample Hs_T_13 (NP07), which had the highest ratio of 0.81, a measurement used as an indication of breast trauma resulting in reopening of paracellular pathways in the mammary tissue (Aryeetey et al., 2008).

The correlation loadings plot (Figure 3.20) displays all of the measured metabolites from the human milk and was used to identify which metabolites were able to contribute to the variance between the human sample set as well as identify metabolites that are positively and negatively correlated with control and nipple pain samples. Metabolites found closer to the middle of the plot do not contain enough structured

variance and cannot be explained by the plot. These were determined inconsequential to a nipple trauma event.

Amino acids, in particular isoleucine and proline, were amongst the metabolites found most positively correlated with human trauma samples. Within the literature there are several studies that have identified a link between an increase in amino acid concentration in response to inflammatory diseases including osteoarthritis, Crohn's disease and inflammatory bowel conditions. Alteration in tissue concentration of amino acids is likely the result of gross tissue destruction or cellular apoptosis (Fitzpatrick & Young, 2013).

A study by Marchesi et al. (2007) of faecal matter from healthy participants and participants with Crohn's disease and ulcerative colitis found a significantly higher quantity of amino acids in participants with inflammatory bowel conditions. An increase in isoleucine concentration (+ 0.69) was observed in the faecal matter of patients with Crohn's when compared to control samples (Marchesi et al., 2007). Other amino acids showing increases included leucine, alanine, lysine and valine. A study by Zhai et al. (2010) of serum from patients with osteoarthritis found an increase in amino acids, in particular valine and leucine, in test patients compared to controls.

Additionally Griffin et al. (2004) used an adenoviral vector to induce a focal inflammatory lesion in rats and identified an increase in urinary amino acids, including leucine, isoleucine and valine, in response to tissue inflammation.

Examples relating to bovine milk also exist in the literature. Sundekilde et al. (2013) profiled bovine milk from cows with mastitis to identify metabolites associated with increased somatic cell count. Again, isoleucine was positively correlated with an

increased somatic cell count and a significant difference was found between healthy cows and cows with mastitis ($p=0.014$). A preliminary bovine study by Ianni et al. (2015) profiled selective amino acids in milk from cows with sub-clinical and clinical mastitis to identify metabolite differences in milk from cows with varying levels of mastitis. This study found that amino acids, aspartic acid, isoleucine and valine were only detectable in the milk from cows with clinical mastitis and not in the sub clinical mastitis milk samples (Ianni et al., 2015). Consequently, it was proposed that these three potential biomarkers could be useful for the confident identification of clinical mastitis in cases that are difficult to diagnose (Ianni et al., 2015). Similarly the measured increase in amino acids in breast milk presented in this thesis may serve as an indication of inflammation and damage to mammary tissue including paracellular pathways.

Due to the small sample numbers resulting from technical problems and instrumental error, we are unable to conclude complete significance of these results. However, the conditions determined and the data provide promising direction for future metabolomics studies. Metabolomics offers opportunities for further refinement of these presented analyses and potential application for more complete human milk analysis if complementary techniques together with the GC-MS analyses presented here were to be combined for a more complete understanding of the milk metabolome.

5 Conclusion

Nipple pain is a common problem for breastfeeding mothers in Australia and often persists for several weeks post partum. As a result it is largely responsible for cessation of breastfeeding in early lactation (weeks 1-4), which can adversely affect the developing infant. It is important to establish the effect of nipple pain and trauma on breast health via breast milk composition, which would then enable rapid diagnosis of pathology, timely intervention and appropriate monitoring of treatment.

In this study microbial analysis of the milk of mothers with nipple pain found limited numbers of potentially pathogenic bacteria, therefore participants were unlikely to have subclinical mastitis, which is reflected also in the pain scores and Na^+/K^+ ratios. However, GC-MS analysis identified differences in metabolite composition between the human control and nipple pain groups. A series of amino acids, previously found to be associated with inflammatory conditions, was elevated in nipple pain milk samples, suggesting that indeed metabolomics may potentially identify mothers with nipple pain that might be predisposed to infection. Consequently, if severity of trauma is related to an underlying infection, then profiling the metabolites may lead to identification of differences in the metabolite composition between mothers'.

Future analysis of human milk should employ LC-MS for analysis of the non-polar fraction of the milk to further the understanding of the milk metabolome. Following the optimisation of an untargeted metabolomics approach, a targeted analysis for the identification of bacterial and fungal metabolites will also increase the potential for diagnosis and provide insight into the breast microbiome.

In conclusion, these results provide preliminary support to confirm the concept that milk expressed by mothers presenting with nipple pain contain compositional differences, detected by metabolomics, which may be related to the early stages of the continuum of mastitis. Further study is required on much larger sample sets to determine the efficacy of this technique in the detection of breast infection and the relationship between compositional change and severity of infection.

References

- Abou-Dakn, M., Richardt, A., Schaefer-Graf, U., & Wöckel, A. (2010). Inflammatory breast diseases during lactation: milk stasis, puerperal mastitis, abscesses of the breast, and malignant tumours – current and evidence-based strategies for diagnosis and therapy. *Breast Care*, 5(1), 33–37. doi:10.1159/000272223
- American Academy of Pediatrics. (1997). Breastfeeding and the use of human milk. *Pediatrics*, 115(2), 496-506. doi: 10.1542/peds.2004-2491
- American Academy of Pediatrics. (2012). Breastfeeding and the use of human milk. *Pediatrics*, 129(3), 827-841. doi: 10.1542/peds.2011-3552
- Amir, L., Forster, D., McLachlan, H. & Lumley, J. (2004). Incidence of breast abscess in lactating women: report from an Australian cohort. *BLOG: an International Journal of Obstetrics and Gynaecology*, 111(12), 1378-1381. doi: 10.1111/j.1471-0528.2004.00272
- Amir, L., Cullinane, M., Garland, S., Tabrizi, S., Donath, S., Bennett, C., Cooklin, A., Fisher, J. & Payne, M. (2011). The role of microorganisms (*Staphylococcus aureus* and *Candida albicans*) in the pathogenesis of breast pain and infection in lactating women: study protocol. *BMC Pregnancy and Childbirth*, 11, 54-64. doi: 10.1186/1471-2393-11-54
- Amir, L., Donath, S., Garland, S., Tabrizi, S., Bennett, C., Cullinane, M., & Payne, M. (2013). Does *Candida* and/or *Staphylococcus* play a role in nipple and breast pain in lactation? A cohort study in Melbourne, Australia. *BMJ Open*, 3(3). doi: 10.1136/bmjopen-2012-002351
- Anatolitou, F. (2012). Human milk benefits and breastfeeding. *Journal of Pediatric and Neonatal Individualized Medicine*, 1(1), 11-18. doi: 10.7363/010113

Arthur, P. G., Smith, M., and Hartman, P. (1989). Milk lactose, citrate and glucose as markers of lactogenesis in normal and diabetic women. *Journal of Pediatric gastroenterology and nutrition*, 9 (4), 488-496.

Australian Breastfeeding Association. (2015). Exclusive expressing. Retrieved from <https://www.breastfeeding.asn.au/bfinfo/exclusive-expressing>

Australian Bureau of Statistics. (2003). Breastfeeding in Australia, 2001 (No. 4810.0.55.001). Retrieved from <http://www.abs.gov.au/ausstats/abs@.nsf/mf/4810.0.55.001>

Aryeetey, R., Marquis, G., Timms, L., Lartey, A., & Brakohiapa, L. (2008). Subclinical mastitis is common among Ghanaian women lactating 3 to 4 months postpartum. *Journal of Human Lactation: Official Journal of International Lactation Consultant Association*, 24(3), 263-7. doi: 10.1177/0890334408316077

Berry, C. (2009). Cells from breastmilk and the mammary gland: Characterisation of storage, apoptosis and Wnt signalling. School of Anatomy and Human Biology, University Of Western Australia. Retrieved from http://repository.uwa.edu.au:80/R/-?func=dbin-jump-full&object_id=13138&silos_library=GEN01

Boudonck, K., Mitchell, M., Wulff, J. & Ryals, J. (2009). Characterization of the biochemical variability of bovine milk using metabolomics. *Metabolomics*, 5(4), 375-386. doi: 10.1007/s11306-009-0160-8

Bressanello, D., Liberto, E., Collino, M., Reichenbach, S., Benetti, E., Chiazza, F., Bicchi, C. & Cordero, C. (2014). Urinary metabolic fingerprinting of mice with diet induced metabolic derangements by parallel dual secondary column-dual detection two-dimensional comprehensive gas chromatography. *Journal of Chromatography A*, 1361, 265-276. doi: 10.1016/j.chroma.2014.08.015

-
- Brown, K., Akhtar, N., Robertson, A., & Ahmed, M. (1986). Lactational capacity of marginally nourished mothers: Relationships between maternal nutritional status and quantity and proximate composition of milk. *Pediatrics*, 78(5), 909-19.
- Buck, M., Amir, L., Cullinane, M., & Donath, S. (2014). Nipple pain, damage, and vasospasm in the first 8 weeks postpartum. *Breastfeeding Medicine*, 9(2), 56-62. doi: 10.1089/bfm.2013.0106
- Chung, M. (2014). Factors Affecting Human Milk Composition. *Pediatrics & Neonatology*, 55(6), 421-422. doi:10.1016/j.pedneo.2014.06.003
- Cooper, A. (1840). *Anatomy of the Breast*. London, UK: Longman, Orme, Green, Browne and Longmans.
- Crepinsek, M., Crowe, L., Michener, K. & Smart, N. (2012). Interventions for preventing mastitis after childbirth. *The Cochrane Database of Systemic Reviews*, 10(1), 1-14. doi: 10.1002/14651858.CD007239.pub3
- De Livera, A., Dias, D., De Souza, D., Rupasinghe, T., Pyke, J., Tull, D., Roessner, U., Mcconville, M. & Speed, T. (2012). Normalizing and integrating metabolomics data. *Analytical Chemistry*, 84(24), 10768-76. doi: 10.1021/ac302748b
- Delgado, S., Arroyo, R., Jimenez, E., Marin, M., del Campo, R., Fernandez, L. & Rodriguez, J. (2009). *Staphylococcus epidermis* strains isolated from breast milk of women suffering infectious mastitis: potential virulence traits and resistance to antibiotics. *BMC Microbiology*, 82(9), 82-93. doi: 10.1186/1471-2180-9-82
- Dunn, W., Broadhurst, D., Begley, P., Zelena, E., Francis-Mcintyre, S., Anderson, N., Brown, M., Knowles, J., Halsall, A., Haselden, J., Nicholls, A., Wilson, I., Kell, D. & Goodacre, R. (2011). Procedures for large-scale metabolic profiling of serum and plasma using gas chromatography and liquid chromatography coupled to mass spectrometry. *Nature Protocols*, 6(7), 1060. doi: 10.1038/nprot.2011.335

Dunnivant, F. & Ginsbach, J. (2008). The gas chromatograph [Image]. Retrieved from http://people.whitman.edu/~dunnivfm/C_MS_Ebook/CH2/2_3.html.

Edmands, W., Barupal, D., & Scalbert, A. (2014). MetMSLine: an automated and fully integrated pipeline for rapid processing of high resolution LC-MS metabolomic datasets. *Bioinformatics*, 31(5), 788-790. doi: 10.1093/bioinformatics/btu705

Eglash, A., Plane, M. & Mundt, M. (2006) History, physical and laboratory findings and clinical outcomes of lactating women treated with antibiotics for chronic breast and/or nipple pain. *Journal of Human Lactation*, 22(4), 429- 433. doi: 10.1177/0890334406293431

Eilers, E., Ziska, T., Harder, T., Plagemann, A., Obladen, M. & Loui, A. (2011). Leptin determination in colostrum and early human milk from mothers of preterm and term infants. *Early Human Development*, 87(6), 415-9. doi: 10.1016/j.earlhumdev.2011.03.004

Ekstroem, A., Widstroem, A., & Nissen, E. (2003). Duration of Breastfeeding in Swedish Primiparous and Multiparous Women. *Journal of Human Lactation*, 19(2), 172-178. doi: 10.1605/01.301-0007911361.2009

Fanos, V., Barberini, L., Antonucci, R. & Atzori, L. (2012). Pharma-metabolomics in neonatology: is it a dream or a fact? *Current Pharmaceutical Design*, 21(18), 2996-3006. Retrieved from <http://www.ingentaconnect.com/content>.

Fetherston, C. (1997). Characteristics of lactation mastitis in a Western Australian cohort. *Breastfeeding Review: Professional Publication of the Nursing Mothers' Association of Australia*, 5(2), 5-11.

Fetherston, C. (2001). Mastitis in lactating women: physiology or pathology? *Breastfeeding Review*, 9(1), 5-12. Retrieved from <http://search.informit.com.au/documentSummary;dn=441738517422302;res=IEL>
APA

-
- Fetherston, C., Lai, C., & Hartmann, P. (2006). Relationships between symptoms and changes in breast physiology during lactation mastitis. *Breastfeeding Medicine : The Official Journal of the Academy of Breastfeeding Medicine*, 1(3), 136-45. doi:10.1089/bfm.2006.1.136
- Filteau, G., Lietz, S., Mulokozi, S., Bilotta, S., Henry, s., & Tomkins, S. (1999). Milk cytokines and subclinical breast inflammation in Tanzanian women: Effects of dietary red palm oil or sunflower oil supplementation. *Immunology*, 97(4), 595-600. doi: 10.1046/j.1365-2567.1999.00834.x
- Fitzpatrick, M., & Young, S. (2013). Metabolomics- a novel window into inflammatory disease. *Swiss Medical Weekly*, 143 (1). doi: 10.4414/smw.2013.13743
- Foxman, B., D'Arcy, H., Gillespie, B., Bobo, J. & Schwatz, K. (2002). Lactation mastitis: occurrence and medical management among 946 breastfeeding women in the United States. *American Journal of Epidemiology*, 155(2), 103-114. doi: 10.1093/aje/155.2.103
- Francki, M., Hayon, S., Gummer, J., Rawlinson, C. & Trengove, R. (2015). Metabolomic profiling and genomic analysis of wheat aneuploidy lines to identify genes controlling biochemical pathways in mature grain. *Plant Biotechnology Journal*, 1-12. doi: 10.1111/pbi.12410
- Geddes, D. (2007). Inside the lactating breast: The latest anatomy research. *Journal of Midwifery & Womens Health*, 52(6), 556-563. doi: 10.1016/j.jmwh.2007.05.004
- Gephart, P., Murray, R., Costilow, R., Nester, W., Wood, W., Krieg, N. and G. B Phillips, G. (1981). *Manual of Methods for General Bacteriology*, ASM Press, Washington D.C.

-
- Godfrey, J., & Lawrence, R. (2010). Toward optimal health: The maternal benefits of breastfeeding. *Journal of Women's Health (2002)*, 19(9), 1597-602. doi: 10.1089/jwh.2010.2290
- Gooding, M., Finlay, J., Shipley, J., Duck, F., & Halliwell, M. (2010). Three-dimensional ultrasound imaging of mammary ducts in lactating women: A feasibility study. *Journal of Ultrasound in Medicine*, 29(1), 95-103.
- Google maps. (2015). Western Australia- Perth region and southwest region. Retrieved from: <https://www.google.com.au/maps/@-32.6080802,115.4925419,8.6z?hl=en>
- Graham, K., Scott, J., Binns, C., & Oddy, W. (2005). National targets for breastfeeding at hospital discharge have been achieved in Perth. *Acta Paediatrica*, 94(3), 352-356. doi: 10.1186/1746-4358-1-28
- Gram, C. (1884). The Differential Staining of Schizomycetes in Tissue Sections and in Dried Preparations. *Fortschritte der Medicin*. 2, 185-189.
- Griffin, Julian L, Anthony, Daniel C, Campbell, Sandra J, Gauldie, Jack, Pitossi, Fernando, Styles, Peter, & Sibson, Nicola R. (2004). Study of cytokine induced neuropathology by high resolution proton NMR spectroscopy of rat urine. *FEBS Letters*, 568(1), 49-54. doi: 10.1016/j.febslet.2004.04.096
- Grote, V., Verduci, E., Scaglioni, S., Vecchi, F., Contarini, G., Giovannini, M., Koletzko, B. & Agostoni, C. (2015). Breast milk composition and infant nutrient intakes during the first 12 months of life. *European Journal of Clinical Nutrition*, 1-7. doi: 10.1038/ejcn.2015.162
- Gullberg, J., Jonsson, P., Nordström, A., Sjöström, M. & Moritz, T. (2004). Design of experiments: An efficient strategy to identify factors influencing extraction and derivatization of *Arabidopsis thaliana* samples in metabolomic studies with gas chromatography/mass spectrometry. *Analytical Biochemistry*, 331(2), 283-295. doi: 10.1016/j.ab.2004.04.037

-
- Gummer, J., Krill, C., Du Fall, L., Waters, O., Trengove, R., Oliver, R. & Solomon, P. (2012). Metabolomics Protocols for Filamentous Fungi. *Plant Fungal Pathogens*. M. D. Bolton and B. P. H. J. Thomma, Humana Press. 835: 237-254. doi: 10.1007/978-1-61779-501-5_15
- Gummer, J., Trengove, R., Oliver, R., & Solomon, P. (2013). Dissecting the role of G-protein signalling in primary metabolism in the wheat pathogen *Stagonospora nodorum*. *Microbiology*, 159 (9), 1972-85. doi: 10.1099/mic.0.067009-0
- Hale, T., & Hartmann, Peter. (2007). *Hale & Hartmann's textbook of human lactation (1st ed.)*. Amarillo, Texas: Hale Publishing.
- Hale, T., Bateman, T., Finkelman, M., & Berens, P. (2009). The absence of *Candida albicans* in milk samples of women with clinical symptoms of ductal candidiasis. *Breastfeeding Medicine : The Official Journal of the Academy of Breastfeeding Medicine*, 4(2), 57-61. doi: 10.1089/bfm.2008.0144
- Hartmann, B., Pang, W., Keil, A. & Simmer, K. (2007). Best practice guidelines for the operation of a donor human milk bank in an Australia NICU. *Early Human Development*, 83(1), 667-673. doi: 10.1016/j.earlhumdev.2007.07.012
- Hassiotou, F. & Geddes, D. (2013). Anatomy of the human mammary gland: Current status of knowledge. *Clinical Anatomy*, 26(1), 29-48. doi: 10.1002/ca.22165
- Hassiotou, F., Hepworth, A., Williams, T., Twigger, A., Perrella, S., Lai, C., Filgueira, L., Geddes, D. & Hartmann, P. (2013). Breastmilk Cell and Fat Contents Respond Similarly to Removal of Breastmilk by the Infant. *PLoS One*, 8(11). doi: 10.1371/journal.pone.0078232
- Hassiotou, F., Hepworth, A., Metzger, P., Tat Lai, C., Trengove, N., Hartmann, P. & Filgueira, L. (2013). Maternal and infant infections stimulate a rapid leukocyte response in breastmilk. *Clinical & Translational Immunology*, 2(4), E3. doi: 10.1038/cti.2013.1

-
- Heikkila, M. & Saris, P. (2003). Inhibition of *Staphylococcus aureus* by the commensal bacteria of human milk. *Journal of Applied Microbiology*, 95(3), 471-478. doi: 10.1046/j.1365-2672.2003.02002.x
- Hogeveen, H., Huijps, K. & Lam, T. (2011). Economic aspects of mastitis: new developments. *New Zealand Veterinary Journal*, 59(1), 16-23. doi: 10.1080/00480169.2011.547165
- Holmen, O. & Bache, B. (2009). An undiagnosed cause of nipple pain presented on a camera phone. *British Medical Journal*, 339(631-632). doi: <http://dx.doi.org/10.1136/bmj.b2553>
- Hothorn, T., Bretz, F., & Westfall, P. (2008). Simultaneous Inference in General Parametric Models. *Biometrical Journal*, 50(3), 346-363. doi: 10.1002/bimj.200810425
- Hsu, Y., Chen, C., Lin, M., Tsai, C., Liang, J. & Wang, T. (2014). Changes in Preterm Breast Milk Nutrient Content in the First Month. *Pediatrics & Neonatology*, 55(6), 449-454. doi: 10.1016/j.pedneo.2014.03.002
- Hubschmann, H. (2008). *Handbook of GC/MS Fundamentals and Applications*. Germany: Wiley.
- Hugenholtz, P. (2002). Exploring prokaryotic diversity in the genomic era. *Genome Biology*, 3(2). Retrieved from <http://genomebiology.com/2002/3/2/reviews/0003.1>
- Ianni, F., Sardella, R., Lisanti, A., Gioiello, A., Cenci Goga, B., Lindner, W. & Natalini, B. (2014). Achiral–chiral two-dimensional chromatography of free amino acids in milk: A promising tool for detecting different levels of mastitis in cows. *Journal of Pharmaceutical and Biomedical Analysis*, 116, 40-46. doi: 10.1016/j.jpba.2014.12.041

-
- Ip, S., Chung, M., Raman, G., Trikalinos, T., & Lau, J. (2009). A summary of the Agency for Healthcare Research and Quality's evidence report on breastfeeding in developed countries. *Breastfeeding Medicine: The Official Journal of the Academy of Breastfeeding Medicine*, 4(1), S17-30. doi: 10.1089/bfm.2009.0050
- Jahanfar, S., Ng, C. & Teng, C. (2013). Antibiotics for mastitis in breastfeeding women. *The Cochrane Database of Systemic Reviews*, 2(1), 1-27. doi: 10.1002/14651858.CD005458.pub3
- Jensen, R. (1995). *Handbook of Milk Composition* (Food Science and Technology). Burlington: Elsevier Science.
- Karlson, E., Mandl, L., Hankinson, S., & Grodstein, F. (2004). Do breast-feeding and other reproductive factors influence future risk of rheumatoid arthritis? Results from the Nurses' Health Study. *Arthritis and Rheumatism*, 50(11), 3458-67. doi: 10.1002/art.20621
- Kirwan, J., Broadhurst, A., Davidson, D., & Viant, I. (2013). Characterising and correcting batch variation in an automated direct infusion mass spectrometry (DIMS) metabolomics workflow. *Analytical and Bioanalytical Chemistry*, 405(15), 5147-5157. doi: 10.1007/s00216-013-6856-7
- Kitson, F., Larsen, B. & McEwen, C. (1996). *Gas Chromatography Mass Spectrometry a Practical Guide*. Burlington, Elsevier.
- Koek, M., Muilwijk, B., vander Werf, M., & Hankemeier, T. (2006). Microbial metabolomics with gas chromatography/mass spectrometry. *Analytical Chemistry*, 78(4), 1272–1281. doi: 10.1021/ac050980b
- Koek, M., Jellema, M., Greef, R., Tas, H., & Hankemeier, J. (2011). Quantitative metabolomics based on gas chromatography mass spectrometry: Status and perspectives. *Metabolomics*, 7(3), 307-328. doi: 10.1007/s11306-010-0254-3

-
- Kvist, L., Larsson, B., Hall-Lord, M., Steen, A., & Schalen, C. (2008). The role of bacteria in lactational mastitis and some considerations of the use of antibiotic treatment. *International Breastfeeding Journal*, 3(6), 6-13. doi: 10.1186/1746-4358-3-6
- Lande, B., Andersen, L., Bærug, A., Trygg, K., Lund-Larsen, K., Veierød, M., & Bjørneboe, G. (2003). Infant feeding practices and associated factors in the first six months of life: The Norwegian Infant Nutrition Survey. *Acta Pædiatrica*, 92(2), 152-161. doi: 10.1111/j.1651-2227.2003.tb00519.x
- Lenth, R. V. (2009). Java Applets for Power and Sample Size [Computer software]. Retrieved from <http://www.stat.uiowa.edu/~rlenth/Power>.
- Love, S. & Barsky, S. (2004). Anatomy of the nipple and breast ducts revisited. *Cancer*, 101(9), 1947-1957. doi: 10.1002/cncr.20559
- Linzell, J. & Peaker, M. (1971). The permeability of mammary ducts. *Journal of physiology*, 216 (3), 701-716.
- Marchesi, J., Holmes, E., Khan, F., Kochhar, S., Scanlan, P., Shanahan, F., Wilson, I. & Wang, Y. (2007). Rapid and noninvasive metabonomic characterization of inflammatory bowel disease. *Journal of Proteome Research*, 6(2), 546-51. doi: 10.1021/pr060470d
- McClellan, H., Geddes, D., Kent, J., Mitoulas, L. & Hartmann, P. (2008). Infants of mothers with persistent nipple pain exert strong sucking vacuums. *Acta Paediatrica*, 97(9), 1205-1209. doi: 10.1111/j.1651-2227.2008.00882.x
- McClellan, K., Hepworth, A., Garbin, C., Rowan, M., Deacon, J., Hartmann, P. & Geddes, T. (2012). Nipple pain during breastfeeding with or without visible trauma. *Journal of Human Lactation*, 28(4), 511-521. doi: 10.1177/0890334412444464

-
- McCrary, C., & Layte, R. (2012). Breastfeeding and risk of overweight and obesity at nine-years of age. *Social Science & Medicine*, 75(2), 323-330.
doi:10.1016/j.socscimed.2012.02.048
- McManaman, J. & Neville, M. (2003). Mammary physiology and milk secretion. *Advanced Drug Delivery Reviews*, 55(5), 629-641.
- Michaelsen, K. F., Lauritzen, L. L., Mortensen, E. H., & Jørgensen, M. (2003). Breast-feeding and brain development. *Scandinavian Journal of Nutrition*, 47(3), 147-151. doi: <http://dx.doi.org/10.1080/11026480310005180>
- Michie, C., Lockie, F. & Lynn, W. (2003). The challenge of mastitis. *Archives of disease in Childhood*, 88(9), 818-821. doi: 10.1136/adc.88.9.818
- Mitoulas, L., Kent, J., Cox, D., Owens, R., Sherriff, J., & Hartmann, P. (2002). Variation in fat, lactose and protein in human milk over 24 h and throughout the first year of lactation. *The British Journal of Nutrition*, 88(1), 29-37. doi: 10.1079/BJN2002579
- Moco, S., Collino, S., Rezzi, S. & Martin, F. (2013). Metabolomics perspectives in pediatric research. *Pediatric Research*, 73(4), 570-576. doi: 10.1038/pr.2013.1
- National Health and Medical Research Council. (2012). Infant feeding guidelines. *National Institute of Clinical Studies- Public Consultation Report*. Retrieved from https://www.nhmrc.gov.au/_files_nhmrc/publications/attachments/n56_infant_feeding_guidelines_150917.pdf
- National Mastitis council. (2012). Interpreting bacteriological culture results to diagnose bovine intramammary infections. Retrieved from <http://nmconline.org/docs/InterpretBactResults.pdf>

-
- Newburg, D. (2005). Innate immunity and human milk. *The Journal of Nutrition*, 135(5), 1308-1312. Retrieved from:
<http://search.proquest.com.ezproxy.library.uwa.edu.au/docview/197468227/abstract?accountid=14681>
- Nommsen, L., Lovelady, C., Heinig, M., Lonnerdal, B. & Dewey, K. (1991). Determinants of energy, protein, lipid, and lactose concentrations in human milk during the first 12 months of lactation: The DARLING Study. (Davis Area Research on Lactation, Infant Nutrition and Growth). *American Journal of Clinical Nutrition*, 53(2), 457.
- Page, T., Lockwood, C. & Guest, K. (2009) Management of nipple pain and/or trauma associated with breastfeeding. *Australian nursing journal*, 17(2), 32-35.
doi: 10.1046/j.1479-697x.2003.00004.x
- Pang, W. & Hartmann. (2007). Initiation of human lactation: secretory differentiation and secretory activation. *Journal of Mammary Gland Biology and Neoplasia*, 12(4), 211-221.
- Pinheiro, J., Bates, C.J., DebRoy, S. & Sarkar, D. (2011). R Development Core team. NLME: Linear and Nonlinear Mixed Effects Models. R package version 3.1–102. R Development Core Team: Vienna, Austria. <http://CRAN.R-project.org/package=nlme>.
- Prentice, A., & Whitehead, R. (1981). Breast-milk fat concentrations of rural African women. *British Journal of Nutrition*, 45(3), 483-494.
- Quinn, E., Largado, F., Power, M. & Kuzawa, C. (2012). Predictors of breast milk macronutrient composition in filipino mothers. *American Journal of Human Biology*, 24(4), 533-40. doi: 10.1002/ajhb.22266
- R Development Core Team. (2011). R: A Language and Environment for Statistical Computing; R Development Core Team: Vienna, Austria.

-
- Ramsay, D., Kent, J., Hartmann, R., & Hartmann, P. (2005). Anatomy of the lactating human breast redefined with ultrasound imaging. *Journal Of Anatomy*, 206(6), 525-534. doi: 10.1111/j.1469-7580.2005.00417.x
- Rowan, M., Deacon, J., Garbin, C., McClellan, H., Watson, M., Fenton, J., Geddes, D., Lai, C. & Hartmann, P. (2008). *Staphylococcus aureus* on sore nipples – is it the causative organism? 14th International Conference of the International Society for Research in Human Milk and Lactation (ISRHML). January 31st – February 5th, 2008, The University Club, Crawley, Western Australia, Australia.
- Schwartz, K., D'Arcy, H., Gillespie, B., Bobo, J., Longeway, M., & Foxman, B. (2002). Factors associated with weaning in the first 3 months postpartum. *Journal of Family Practice*, 51(5), 439. Retrieved from <http://web.b.ebscohost.com.ezproxy.library.uwa.edu.au/ehost/pdfviewer/pdfviewer?sid=ed17b4f1-d2ad-463a-b360-5c7e299ebfeb%40sessionmgr113&vid=2&hid=116>
- Schwarz, E., Brown, J., Creasman, J., Stuebe, A., McClure, C., Van Den Eeden, S., & Thom, D. (2010). Lactation and maternal risk of type 2 diabetes: A population-based study. *The American Journal of Medicine*, 123(9), 863-863. doi: 10.1016/j.amjmed.2010.03.016
- Scott, J., Binns, C., Oddy, W. & Graham, K. (2006). Predictors of breastfeeding duration: Evidence from a cohort study. *Pediatrics*, 117(4), 1404. doi: 10.1542/peds.2005-1991
- Shennan, D., & Peaker, M. (2000). Transport of milk constituents by the mammary gland. *Physiological Reviews*, 80(3), 925-51.
- Smolinska, A., Blanchet, L., Buydens, L. & Wijmenga, S. (2012). NMR and pattern recognition methods in metabolomics: From data acquisition to biomarker discovery: A review. *Analytica Chimica Acta*, 750(1), 82-97. doi: 10.1016/j.aca.2012.05.049

-
- Strathearn, L., Mamun, A., Najman, J., & O'Callaghan, M. (2009). Does breastfeeding protect against substantiated child abuse and neglect? A 15-year cohort study. *Pediatrics*, *123*(2), 483-93. doi: 10.1542/peds.2007-3546
- Sundekilde, U., Poulsen, N., Larsen, L. & Bertram, H. (2013). Nuclear magnetic resonance metabonomics reveals strong association between milk metabolites and somatic cell count in bovine milk. *Journal of Dairy Science*, *96*(1), 290-299. doi: 10.3168/jds.2012-5819
- Tait, P. (2000). Nipple pain in breastfeeding women: causes, treatment, and prevention strategies. *Journal of Midwifery and Women's Health*, *45*(3), 212-215. doi: 10.1016/S1526-9523(00)00011-8
- Thomas, E., Williams, T. and Hartmann, P. (2010). Lactation and mother's milk: recent advances in understanding. *Infant*, *6* (3), 86-90.
- Thomsen, A., Hansen, K. & Moller, B. (1983). Leukocyte counts and microbiologic cultivation in the diagnosis of puerperal mastitis. *American Journal of Obstetrics and Gynecology*, *146*(8), 938-941. Retrieved from <http://europepmc.org/abstract>.
- Veselkov, K., Vingara, L., Masson, P., Robinette, S., Want, E., Li, J., Barton, R., Boursier-Neyret, C., Walther, B., Ebbles, T., Pelczer, I., Holmes, E., Lindon, J. & Nicholson, J. (2011). Optimized preprocessing of ultra-performance liquid chromatography/mass spectrometry urinary metabolic profiles for improved information recovery. *Analytical Chemistry*, *83*(15), 5864-5872. doi: 10.1021/ac201065j
- Walker, A. (2010). Breast milk as the golden standard for protective nutrients. *The Journal of Pediatrics*, *152* (2), 3-7. doi: 10.1016/j.jpeds.2009.11.021
- WHO (1985). World Health Organization Collaborative Study of Breastfeeding: The Quantity and quality of breast milk: Report on the WHO Collaborative Study of Breastfeeding. World Health Organisation Geneva, Switzerland.

WHO. (2003). Global strategy for infant and young child feeding. World Health Organisation Geneva, Switzerland.

Win, N., Binns, C., Zhao, Y., Scott, J. and Oddy, W. (2006). Breastfeeding duration in mothers who express breast milk: A cohort study. *International Breastfeeding Journal*, 1, 28-32. doi: 10.1186/1746-4358-1-28

Wojcik, K., Rechtman, D., Lee, M., Montoya, A. & Medo, E. (2009). Macronutrient analysis of a nationwide sample of donor breast milk. *Journal Of The American Dietetic Association*, 109(1), 137-140. doi: 10.1016/j.jada.2008.10.008

Zhai, G., Wang-Sattler, R., Hart, D., Arden, N., Hakim, A., Illig, T., & Spector, T. (2010). Serum branched-chain amino acid to histidine ratio: A novel metabolomic biomarker of knee osteoarthritis. *Annals of the Rheumatic Diseases*, 69(6), 1227. doi: 10.1136/ard.2009.120857

Zhang, Q., Wang, G., Du, Y., Zhu, L., & A, J. (2007). GC/MS analysis of the rat urine for metabonomic research. *Journal of Chromatography B*, 854(1), 20-25. doi: 10.1016/j.jchromb.2007.03.048

Ziebuhr, W., Hennig, S., Eckart, M., Kranzler, H., Batzilla, C. & Kozitskaya, S. (2006). Nosocomial infections by *Staphylococcus epidermis*: how a commensal bacterium turns into a pathogen. *International Journal of Antimicrobial Agents*, 28, 14-20. doi:10.1016/j.ijantimicag.2006.05.012

Appendices

Appendix 2.1 Consent form provided to all participants prior to milk collection.



Biochemistry and Molecular Biology
School of Biomedical, Biomolecular and Chemical Sciences
M310, The University of Western Australia
35 Stirling Highway
CRAWLEY WA 6009
Prof. Peter E. Hartmann
Telephone: +61 (0)8 6488 3327
Facsimile: +61 (0)8 6488 1148
Email: hartmanp@cyllene.uwa.edu.au

Breastfeeding Centre of Western Australia:
Agnes Walsh House
King Edward Memorial Hospital for Women
Bagot Road
SUBIACO WA 6008

Telephone +61 (0)8 9340 1846

Composition of human milk

Consent Form

This study aims to learn more about the composition of human milk and the changes in concentration during the day and throughout lactation, and possible contaminants.

I

FAMILY NAME

GIVEN NAMES

have read the information sheet about this study and any questions I have asked have been answered to my satisfaction. I agree to participate in this activity, realising that I may withdraw at any time without reason and without prejudice.

I understand that all information provided is treated as strictly confidential and will not be released by the investigator unless required to do so by law.

I have been advised as to what data is being collected, what the purpose is, and what will be done with the data upon completion of the research.

I agree that research data gathered for the study may be published provided my name or other identifying information is not used.

Participant Date

The Human Research Ethics Committee at the University of Western Australia requires that all participants are informed that, if they have any complaint regarding the manner, in which a research project is conducted, it may be given to the researcher or, alternatively to the Secretary, Human Research Ethics Committee, Registrar's Office, The University of Western Australia, 35 Stirling Highway, Crawley, WA 6009 (telephone number 6488-3703). All study participants will be provided with a copy of the Information Sheet and Consent Form for their personal records.

Appendix 2.2. General information sheet provided to all participants prior milk collection.

Have you previously participated in a study with the Hartmann Human Lactation Research Group?	
First Name	
Last Name	
DOB Baby (dd/mm/yy)	
DOB mother (dd/mm/yy)	
Email	
Phone/Mobile	
Address	
Number of Children	
Have you done a HIV and Hepatitis check?	
If you have other children, did you breastfeed any of them? If yes, for how long?	
General Healthy Status of mother/baby (presence of nipple pain trauma/no trauma)	
Current Medication	

Visual Analogue Scale (pain intensity during breastfeeding)

No pain

Worst Pain Imaginable



Appendix 2.3. Online questionnaire which participants were asked to fill out following milk ample collection.

Retrieved from: <https://breastfeeding.bcs.uwa.edu.au>

Section A

Date of Birth
Last year of completed education
Further completed education
Marital Status
Number of Children
Ethnic Group
Height and Weight
Left or Right handed

Section B

Bra Size before pregnancy
Current Bra Size
Breast Piercing
Did you smoke during pregnancy?
Do you smoke now?
List of experienced problems:
High Blood Pressure
Gestational Diabetes
Antenatal Bleeding
Postpartum Haemorrhage
Depression
Hospitalisation for any reason
Current medications
Allergies

Section C

Infant Gender
Infant Date of Birth
Gestational Weeks and Days
Birth Weight
Birth Length

Birth Apgar Scores
Mode of Delivery
Drugs during delivery
Was the baby admitted to special Care nursery?
Special Care Nursery Details?
Baby's allergies
Baby's current medications
Time before baby's first feed
Day milk came in
Baby feed method
Intended baby feed length
Baby's weight at 6 weeks
Baby's dummy usage
Breastfeeding relationship concerns

Appendix 3.1. Human sample demographic data.

Participant ID	Group ID	Right Breast	Left Breast	Mother Age (Years)	Infant Age (Weeks)	Parity	AB (Y/N)	Pain (1-10)
M01	C01	Control	N/A	23.65	11.9	1	N	0
M02	C02/NP05	NP-No Trauma	Control	29.15	5.9	1	N	8
M03	C03/NP10	NP-Trauma	Control	31.7	5.7	1	Y	6
M04	C04	Control	N/A	28.39	15.7	2	N	0
M05	C05	Control	N/A	25.78	8.3	2	N	0
M06	C06	N/A	Control	32.84	16.3	3	N	0
M07	C07	Control	N/A	30.87	17.7	2	N	0
M08	C08	Control	N/A	29.84	21.1	1	N	0
M09	C09	Control	N/A	30.72	25.6	2	N	0
M10	C10	N/A	Control	40.2	25.7	1	N	0
M11	C11	Control	N/A	34.35	26.1	2	N	0
M12	C12	Control	N/A	34.34	10.7	3	N	0
M13	C13	Control	N/A	22.59	19.7	2	N	0
M14	C14	N/A	Control	35.06	17.4	2	N	0
M15	C15	Control	N/A	32.8	22.7	1	N	0
M16	C16	Control	N/A	33.28	22.3	1	N	0

M17	C17	N/A	Control	40.8	14	3	N	0
M18	C18/NP02	NP-No Trauma	Control	28.06	10.4	1	N	10
M19	C19	Control	N/A	22.19	5	2	N	0
M20	C20	N/A	Control	31.26	7.6	2	N	0
M21	C21	Control	N/A	24.18	7.1	1	N	0
M22	C22/NP06	Control	NP-No Trauma	34.82	7.1	1	N	2
M23	NP01	NP-No Trauma	N/A	28.94	21.6	1	N	4
M24	NP03	N/A	NP-No Trauma	40.43	6.9	1	N	3
M25	NP04	NP-No Trauma	N/A	39.18	6.9	4	N	8
M26	NP07	NP-Trauma	N/A	37.11	5.1	2	N	5
M27	NP08	NP-Trauma	N/A	35.87	4.6	2	N	4
M28	NP09	NP-Trauma	N/A	29.5	7	2	N	7
M29	NP11	NP-Trauma	N/A	34.79	22.7	2	N	4

Highlighted rows indicate participants who were suffering from unilateral nipple pain and provided a control and nipple pain sample.

Appendix 3.3. CFU counts for blood agar cultures of human milk samples and individual and pooled vat bovine milk samples.

Participant ID	Sample ID	Group	CFU/ml
M01	C01	Control	500
M02*	C02	Control	2670
M03*	C03	Control	0
M04	C04	Control	1050
M05	C05	Control	300
M06	C06	Control	18680
M07	C07	Control	50
M08	C08	Control	10
M09	C09	Control	760
M10	C10	Control	80
M11	C11	Control	70
M12	C12	Control	10
M13	C13	Control	70
M14	C14	Control	50
M15	C15	Control	500
M16	C16	Control	400
M17	C17	Control	310
M18*	C18	Control	2500
M19	C19	Control	130
M20	C20	Control	6750
M21	C21	Control	500
M22*	C22	Control	320
M23	NP01	Pain- No Trauma	20
M18*	NP02	Pain- No Trauma	760
M24	NP03	Pain- No Trauma	580
M25	NP04	Pain- No Trauma	690
M02*	NP05	Pain- No Trauma	380
M22*	NP06	Pain- No Trauma	210
M26	NP07	Pain- Trauma	110
M27	NP08	Pain- Trauma	450

M28	NP09	Pain- Trauma	990
M03*	NP10	Pain- Trauma	12000
M29	NP11	Pain- Trauma	340
B01	BC01	Control	410
B01	BM01	Mastitis (Untreated)	330
B01	BM02	Mastitis (Untreated)	1010
B02	BM03	Mastitis (Treated)	1400
B02	BC02	Control	20
B03	BC03	Control (Colostrum)	30
B04	BM04	Mastitis (Untreated)	50
V01	BV01	VAT 1	4630
V02	BV02	VAT 2	4330

(*) Indicates paired samples for human participants who donated both a control and nipple pain sample.

Appendix 3.4. Complete Na⁺/K⁺ data set.

Participant ID	Sample ID	Group	Na⁺ (mM)	K⁺ (mM)	Na⁺/K⁺ Ratio
M01	C01	Control	6.490	12.416	0.523
M02*	C02	Control	5.744	14.403	0.399
M03*	C03	Control	4.073	13.461	0.303
M04	C04	Control	4.555	11.757	0.387
M05	C05	Control	7.138	12.635	0.565
M06	C06	Control	5.126	13.431	0.382
M07	C07	Control	4.699	13.199	0.356
M08	C08	Control	4.407	12.553	0.351
M09	C09	Control	3.613	11.108	0.325
M10	C10	Control	3.948	13.379	0.295
M11	C11	Control	4.918	13.579	0.362
M12	C12	Control	4.490	13.608	0.330
M13	C13	Control	3.933	12.858	0.306
M14	C14	Control	4.593	11.886	0.386
M15	C15	Control	5.222	15.013	0.348
M16	C16	Control	2.541	10.047	0.253
M17	C17	Control	3.204	12.443	0.257
M18*	C18	Control	3.613	10.541	0.343
M19	C19	Control	3.990	13.274	0.301
M20	C20	Control	3.409	11.527	0.296
M21	C21	Control	2.698	14.275	0.189
M22*	C22	Control	2.621	12.447	0.211
M23	NP01	Pain- No Trauma	3.641	11.217	0.325
M18*	NP02	Pain- No Trauma	4.809	13.466	0.357
M24	NP03	Pain- No Trauma	6.068	14.179	0.428
M25	NP04	Pain- No Trauma	9.212	16.552	0.557
M02*	NP05	Pain- No Trauma	4.720	14.332	0.329
M22*	NP06	Pain- No Trauma	6.392	11.527	0.555
M26	NP07	Pain- Trauma	11.528	14.209	0.811
M27	NP08	Pain- Trauma	7.032	14.580	0.482

M28	NP09	Pain- Trauma	7.300	14.301	0.510
M03*	NP10	Pain- Trauma	9.136	16.875	0.541
M29	NP11	Pain- Trauma	5.204	12.277	0.424
B01	BC01	Control	19.779	21.011	0.941
B01	BM01	Mastitis (Untreated)	45.482	12.789	3.556
B01	BM02	Mastitis (Untreated)	29.776	17.654	1.687
B02	BM03	Mastitis (Treated)	26.562	20.432	1.300
B02	BC02	Control	8.442	25.495	0.331
B03	BC03	Control (Colostrum)	22.357	24.527	0.912
B04	BM04	Mastitis (Untreated)	19.213	25.440	0.755
V01	BV01	VAT 1	11.528	24.058	0.479
V02	BV02	VAT 2	11.552	24.370	0.474

** Indicate mothers that have given both a control and nipple pain sample*

Appendix 3.5a Measured peak area of L-Methionine (1 TMS) MSTFA incubation temperatures of 37°C, 45°C, 60°C, 75°C, 90°C with the incubation performed in a GC oven (GC) or with agitation in a Thermomixer (TM).

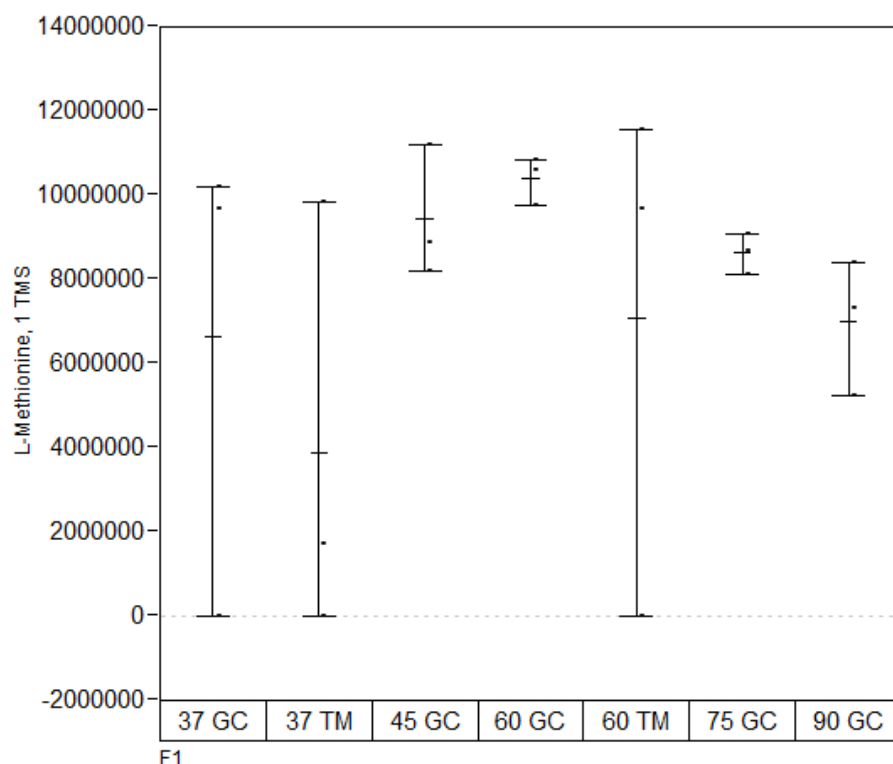

Appendix 3.5b Standard deviation of the measured peak area (n=3) L-Methionine (1 TMS) using MSTFA incubation temperatures of 37°C, 45°C, 60°C, 75°C, 90°C with the incubation performed in a GC oven (GC) or with agitation in a Thermomixer (TM).

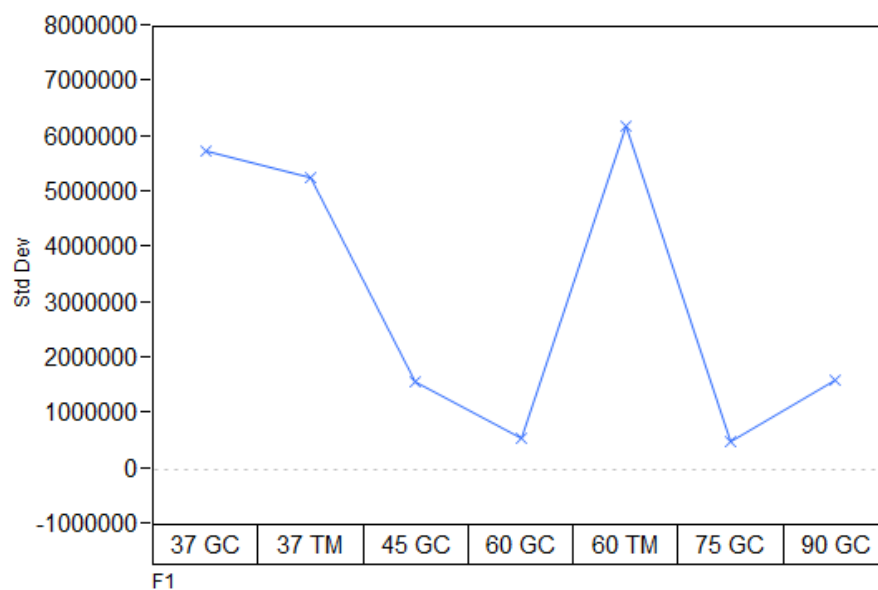

Appendix 3.5c Measured peak area of Aspartic acid (2 TMS) using MSTFA incubation temperatures of 37°C, 45°C, 60°C, 75°C, 90°C with the incubation performed in a GC oven (GC) or with agitation in a Thermomixer (TM).

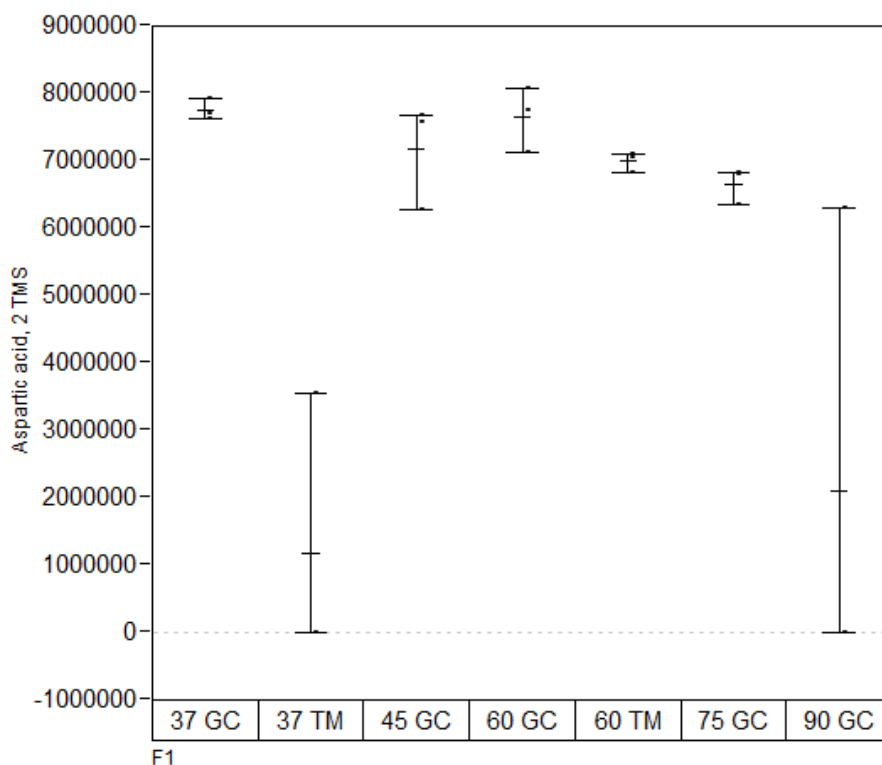

Appendix 3.5d Standard deviation of the measured peak (n=3) of Aspartic acid (2 TMS) using MSTFA incubation temperatures of 37°C, 45°C, 60°C, 75°C, 90°C with the incubation performed in a GC oven (GC) or with agitation in a Thermomixer (TM).

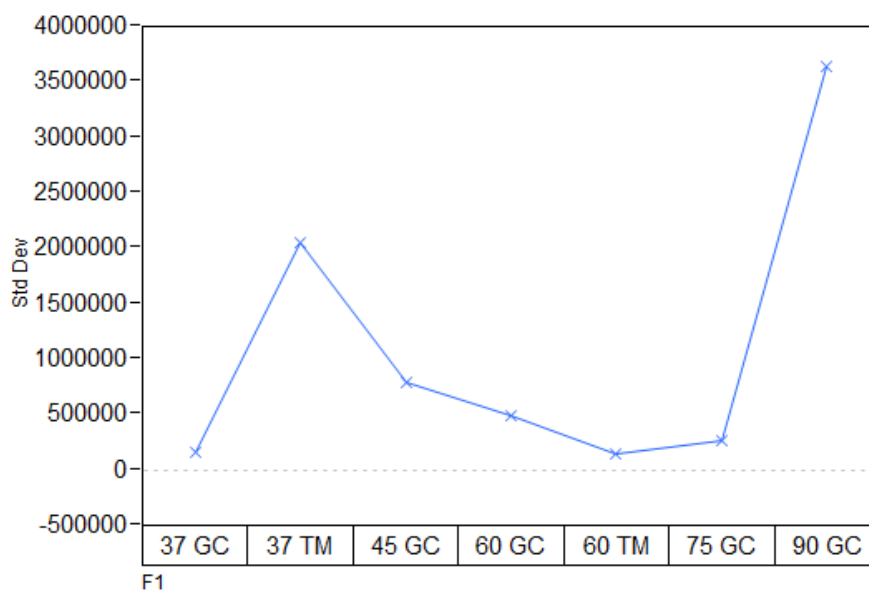

Appendix 3.5e Measured peak area of Mix N Unknown 1 using MSTFA incubation temperatures of 37°C, 45°C, 60°C, 75°C, 90°C with the incubation performed in a GC oven (GC) or with agitation in a Thermomixer (TM).

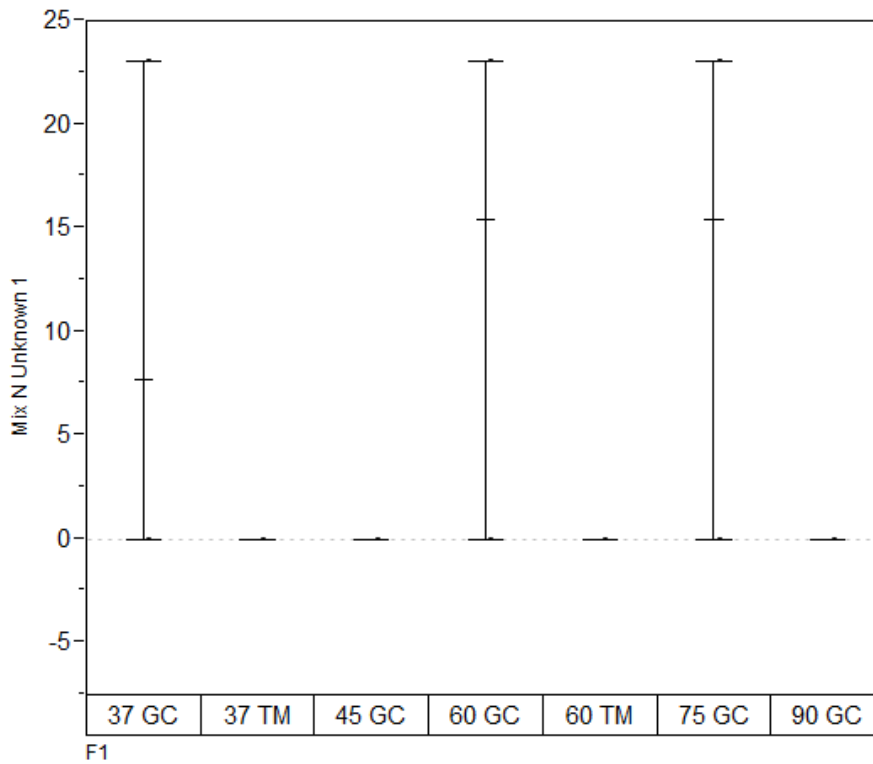

Appendix 3.5f Standard deviation of the measured peak area (n=3) of Mix N Unknown 1 using MSTFA incubation temperatures of 37°C, 45°C, 60°C, 75°C, 90°C with the incubation performed in a GC oven (GC) or with agitation in a Thermomixer (TM).

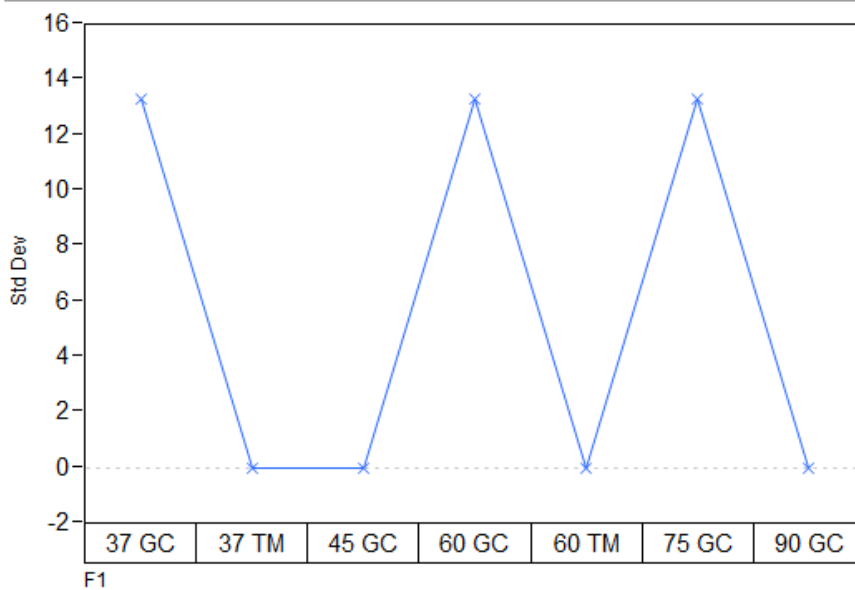

Appendix 3.5g Measured peak area of Ribitol (5 TMS) using MSTFA incubation temperatures of 37°C, 45°C, 60°C, 75°C, 90°C with the incubation performed in a GC oven (GC) or with agitation in a Thermomixer (TM).

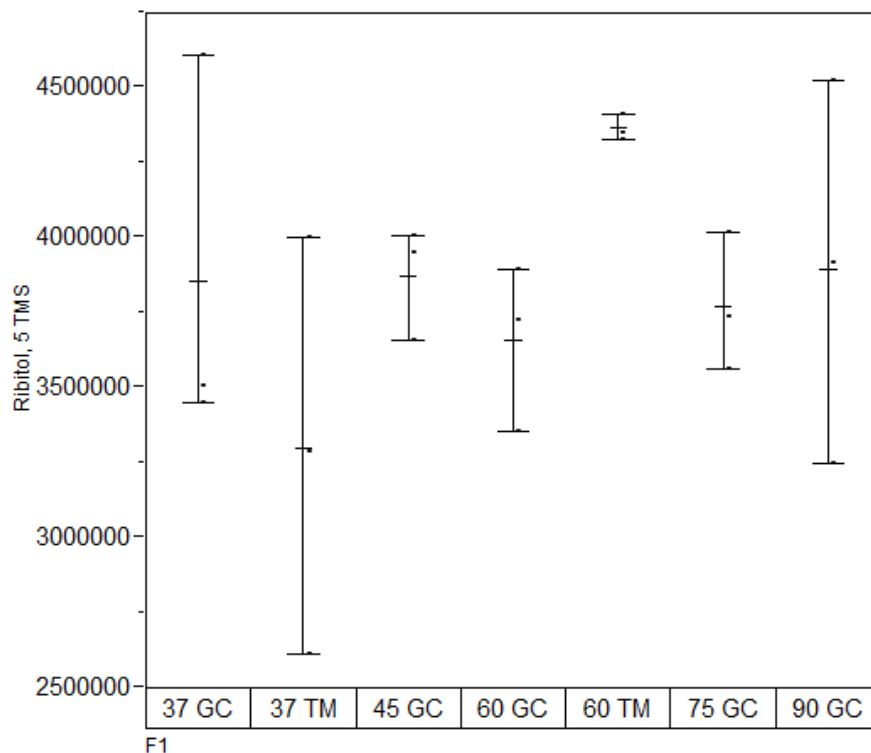

Appendix 3.5h Standard deviation of the measured peak area (n=3) of Ribitol (5 TMS) using MSTFA incubation temperatures of 37°C, 45°C, 60°C, 75°C, 90°C with the incubation performed in a GC oven (GC) or with agitation in a Thermomixer (TM).

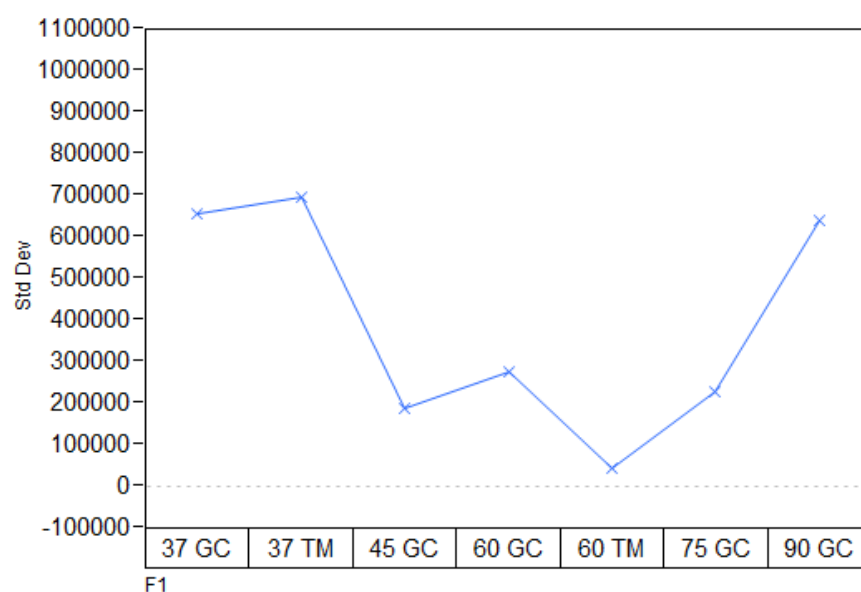

Appendix 3.5i Measured peak area of Mannitol (6 TMS) using MSTFA incubation temperatures of 37°C, 45°C, 60°C, 75°C, 90°C with the incubation performed in a GC oven (GC) or with agitation in a Thermomixer (TM).

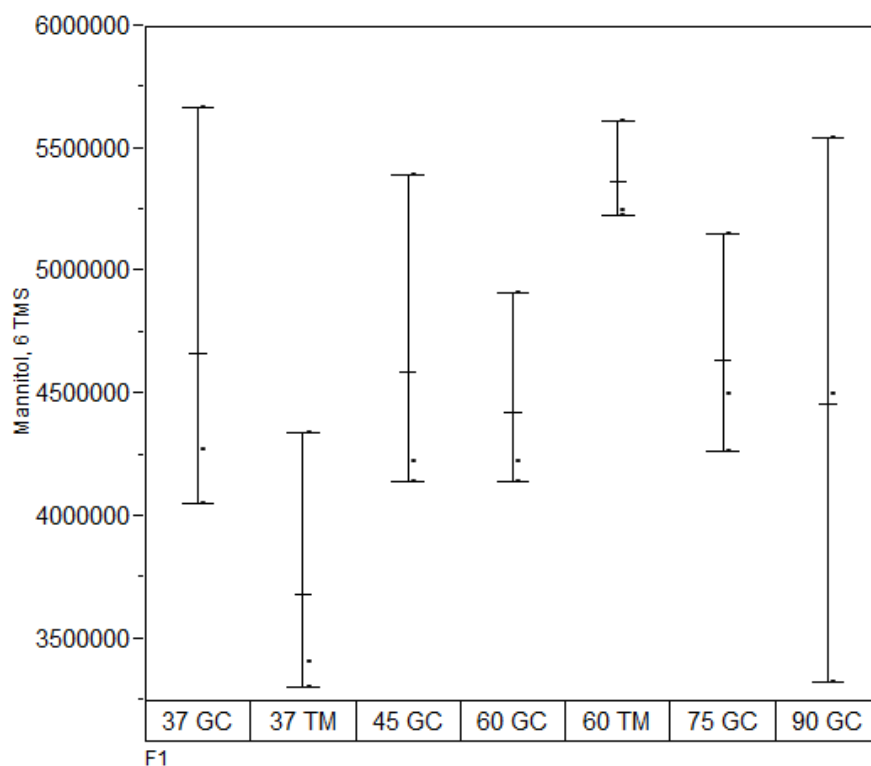

Appendix 3.5j Standard deviation of the measured peak area (n=3) of Mannitol (6 TMS) using MSTFA incubation temperatures of 37°C, 45°C, 60°C, 75°C, 90°C with the incubation performed in a GC oven (GC) or with agitation in a Thermomixer (TM).

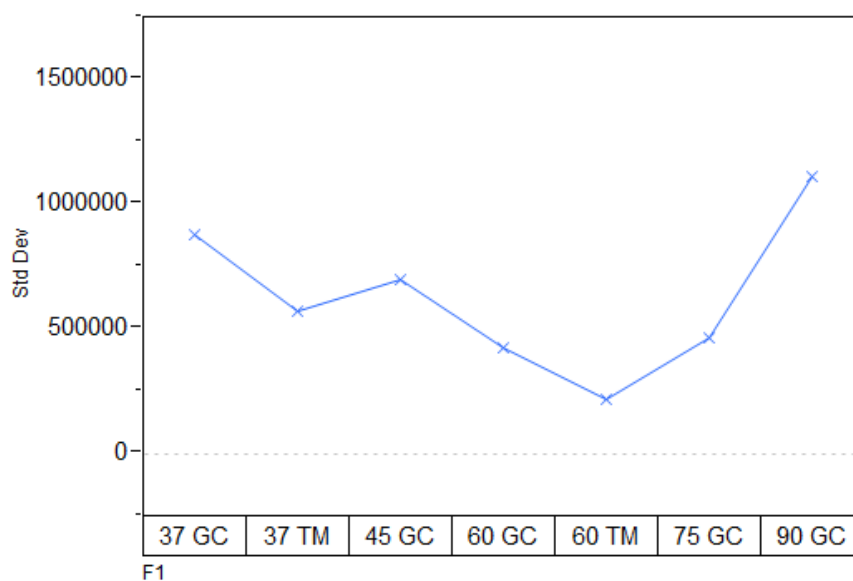

Appendix 3.5k Measured peak area of D(-)-Fructose (5 TMS, 1 MEOX) using MSTFA incubation temperatures of 37°C, 45°C, 60°C, 75°C, 90°C with the incubation performed in a GC oven (GC) or with agitation in a Thermomixer (TM).

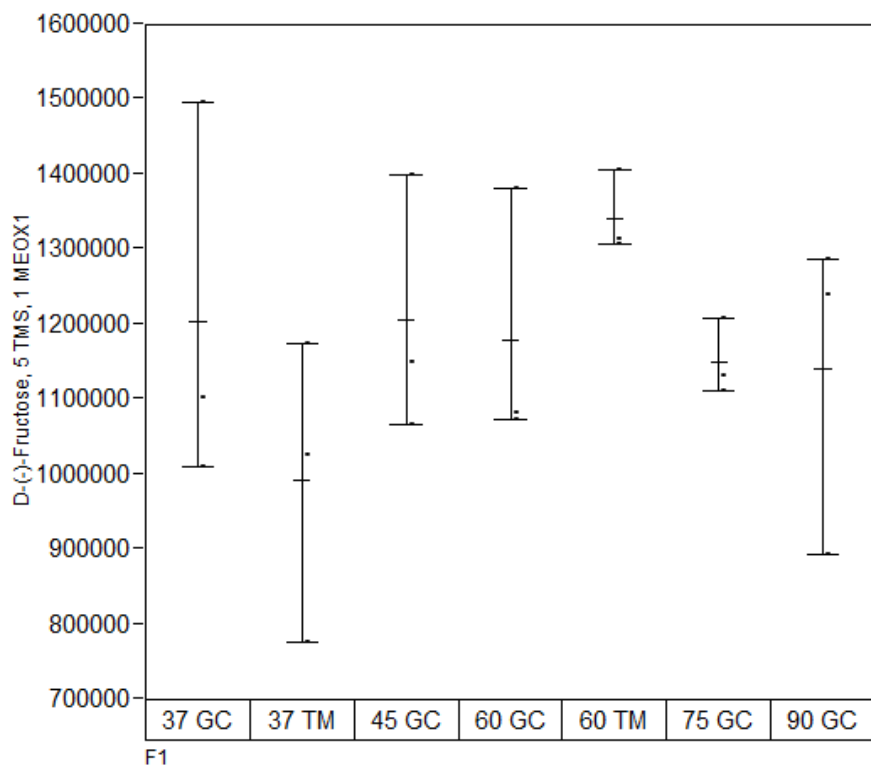

F1

Appendix 3.5l Standard deviation of the measured peak area (n=3) of D(-)-Fructose (5 TMS, 1 MEOX) using MSTFA incubation temperatures of 37°C, 45°C, 60°C, 75°C, 90°C with the incubation performed in a GC oven (GC) or with agitation in a Thermomixer (TM).

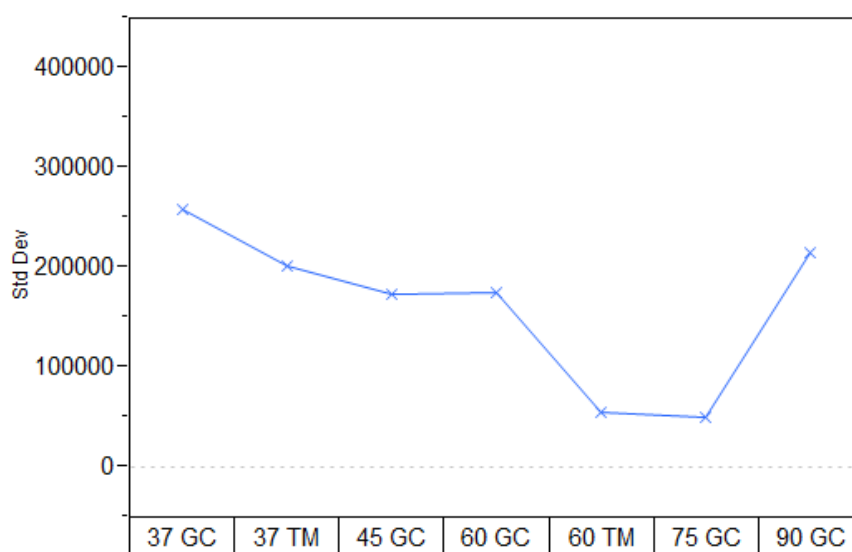

F1

Appendix 3.5m Measured peak area of Citric acid (4 TMS) using MSTFA incubation temperatures of 37°C, 45°C, 60°C, 75°C, 90°C with the incubation performed in a GC oven (GC) or with agitation in a Thermomixer (TM).

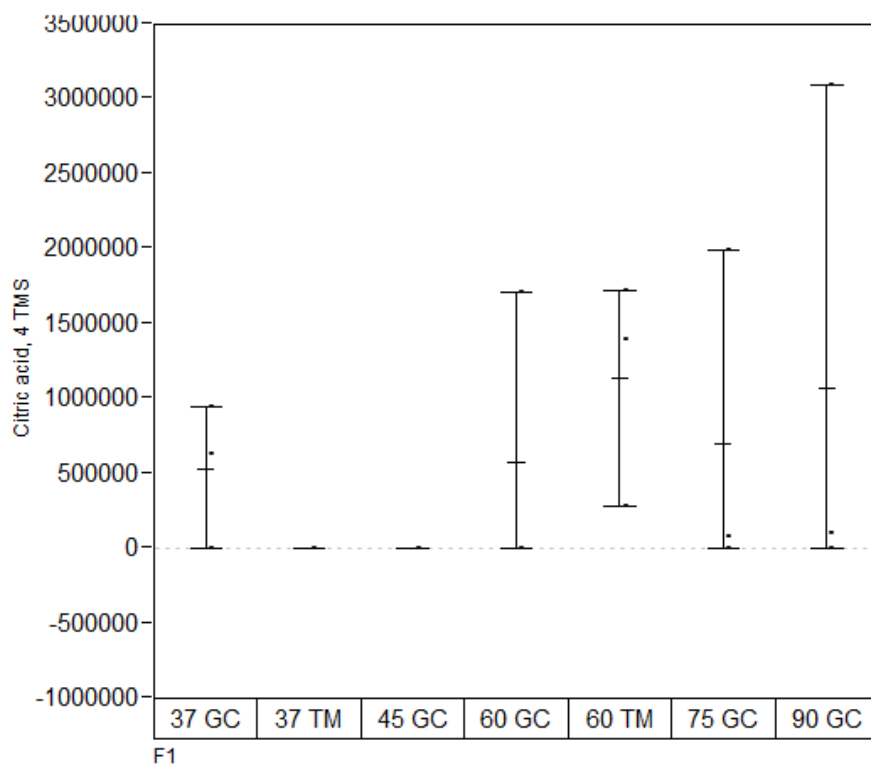

Appendix 3.5n Standard deviation of the measured peak area (n=3) of Citric acid (4 TMS) using MSTFA incubation temperatures of 37°C, 45°C, 60°C, 75°C, 90°C with the incubation performed in a GC oven (GC) or with agitation in a Thermomixer (TM).

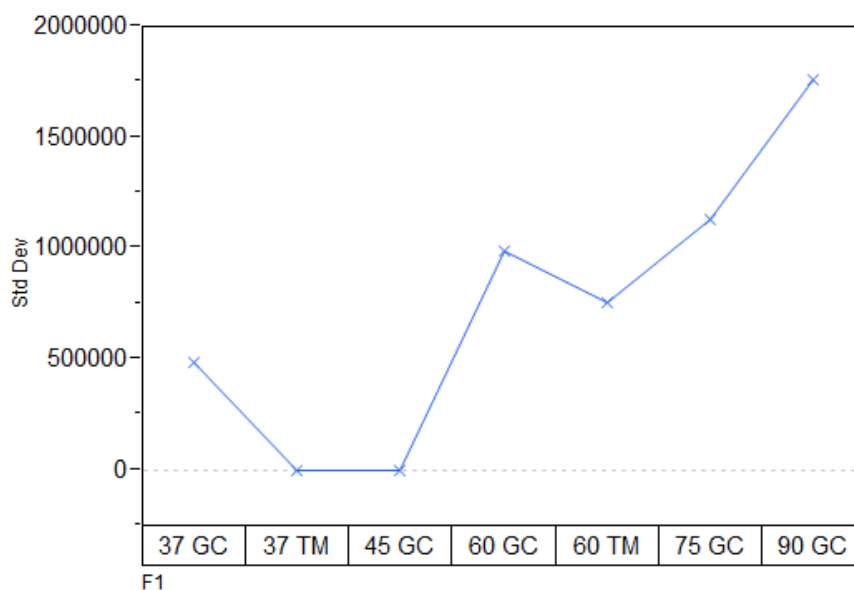

Appendix 3.5o Measured peak area of Putrescine using MSTFA incubation temperatures of 37°C, 45°C, 60°C, 75°C, 90°C with the incubation performed in a GC oven (GC) or with agitation in a Thermomixer (TM).

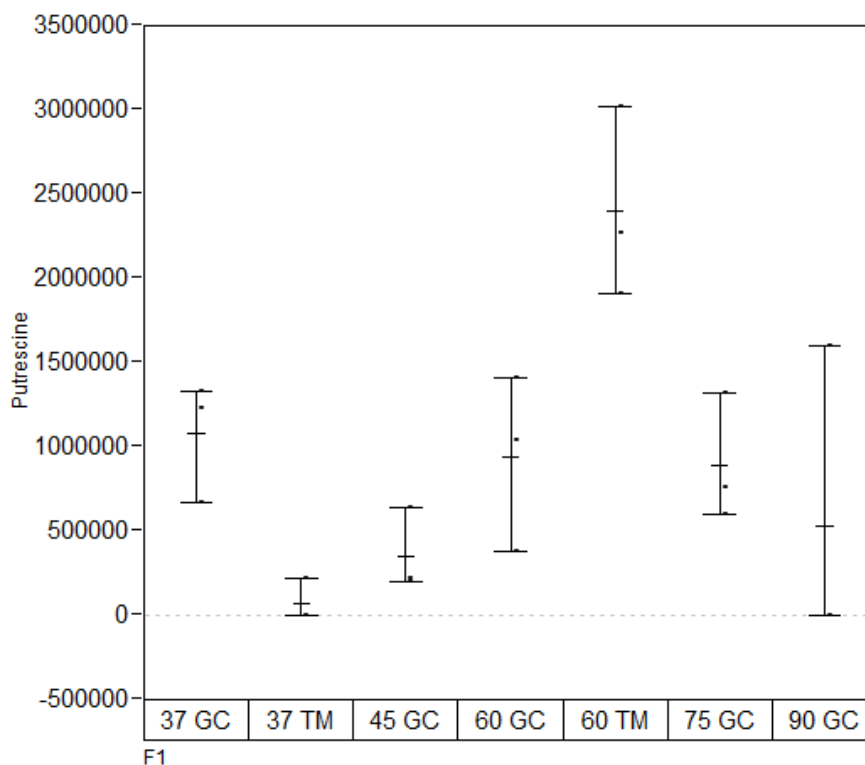

Appendix 3.5p Standard deviation of the measured peak area (n=3) of Putrescine using MSTFA incubation temperatures of 37°C, 45°C, 60°C, 75°C, 90°C with the incubation performed in a GC oven (GC) or with agitation in a Thermomixer (TM).

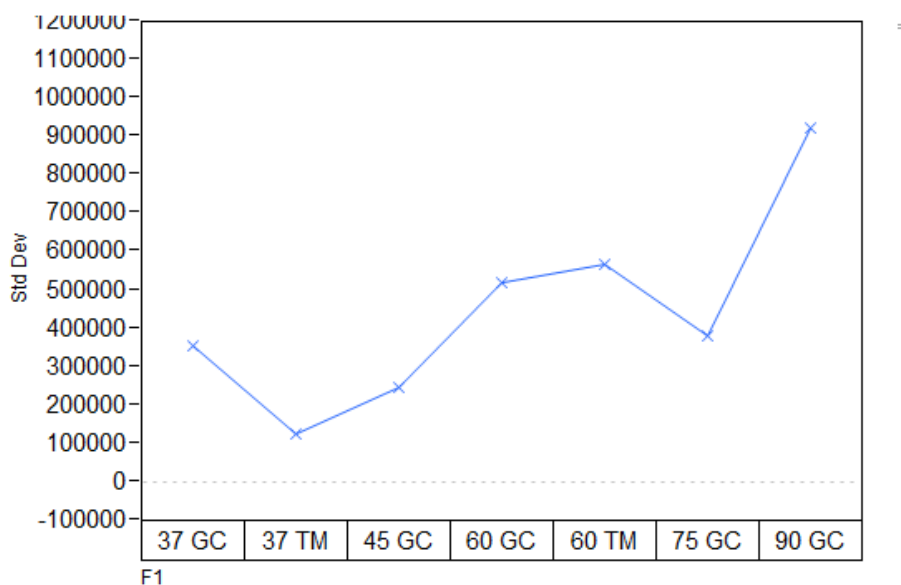

Appendix 3.5q Measured peak area of Sorbitol (5 TMS) using MSTFA incubation temperatures of 37°C, 45°C, 60°C, 75°C, 90°C with the incubation performed in a GC oven (GC) or with agitation in a Thermomixer (TM).

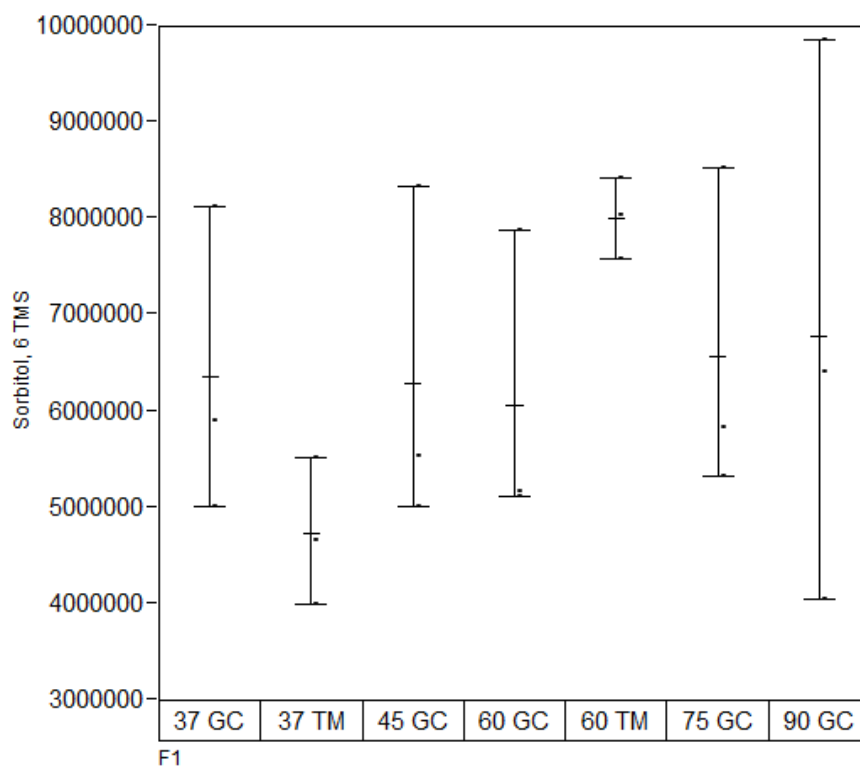

Appendix 3.5r Standard deviation of the measured peak area (n=3) of Sorbitol (5 TMS) using MSTFA incubation temperatures of 37°C, 45°C, 60°C, 75°C, 90°C with the incubation performed in a GC oven (GC) or with agitation in a Thermomixer (TM).

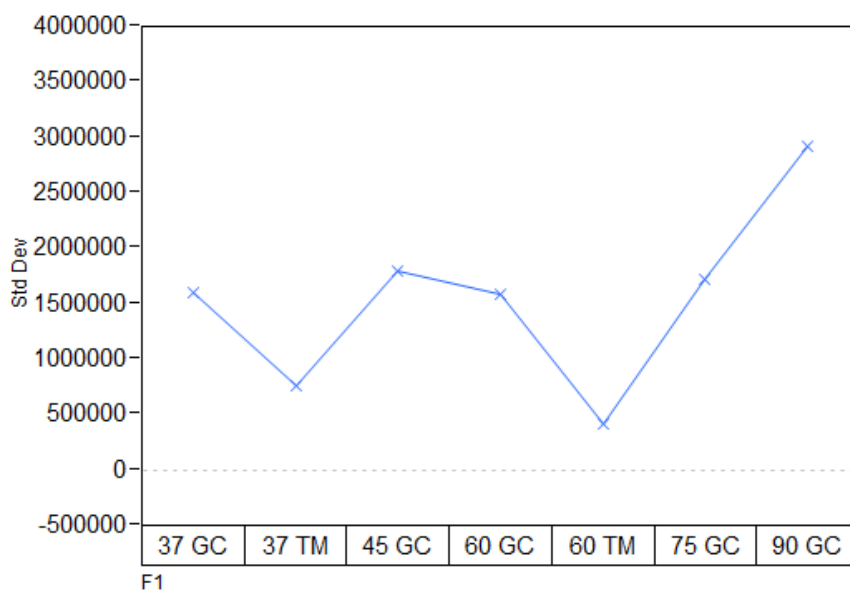

Appendix 3.5s Measured peak area of Myo-inositol (6 TMS) using MSTFA incubation temperatures of 37°C, 45°C, 60°C, 75°C, 90°C with the incubation performed in a GC oven (GC) or with agitation in a Thermomixer (TM).

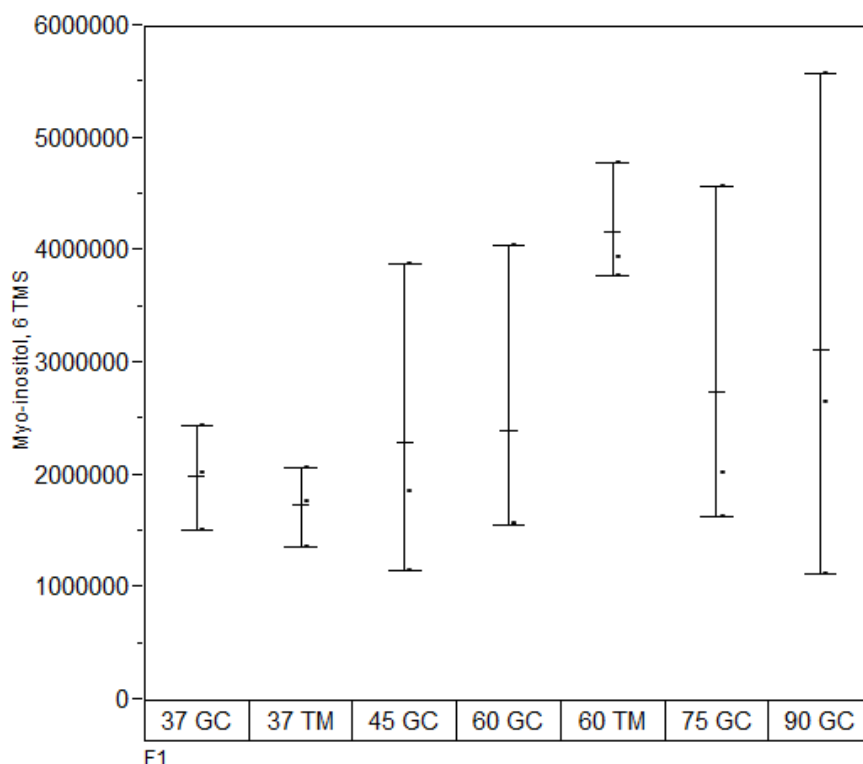

Appendix 3.5t Standard deviation of the measured peak area (n=3) of Myo-inositol (6 TMS) using MSTFA incubation temperatures of 37°C, 45°C, 60°C, 75°C, 90°C with the incubation performed in a GC oven (GC) or with agitation in a Thermomixer (TM).

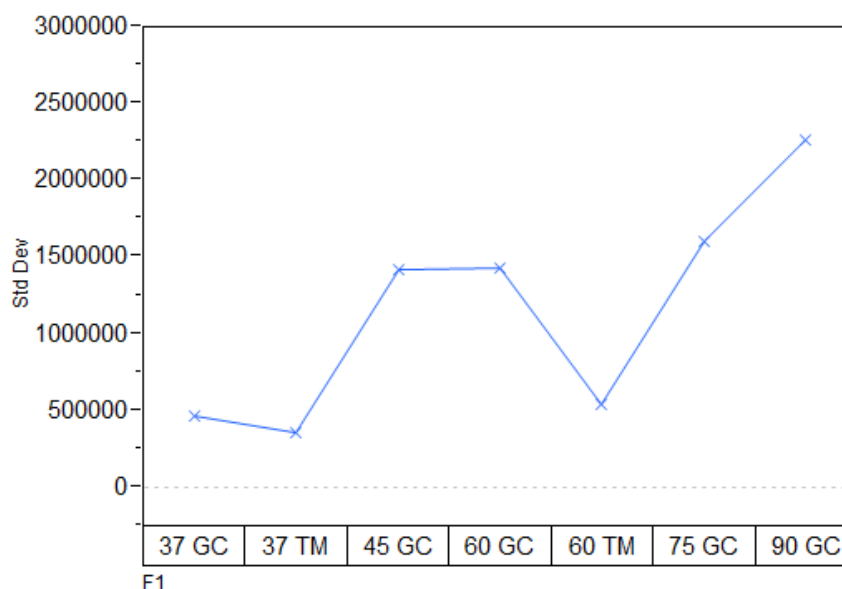

Appendix 3.6 Scores plot of PC-1 (18%) vs. PC-2 (11%) illustrating the reproducibility of the pooled quality controls

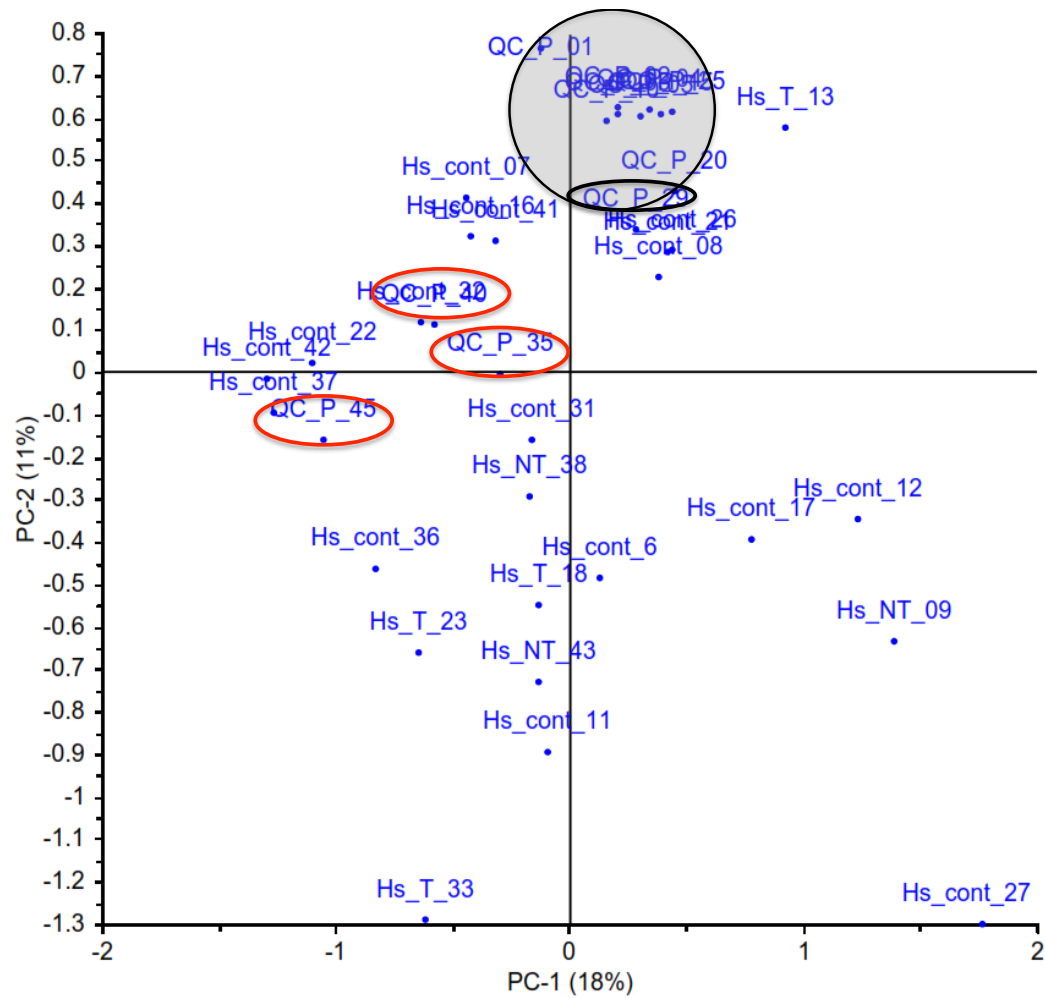

The black circle indicates the cluster of QCs with comparatively lower variance; the red circles indicate where variation in QCs is introduced by instrumental maintenance cycles.