

Macalester Journal of Physics and Astronomy

Volume 5
Issue 1 Spring 2017

Article 4

May 2017

Conductivity Measurements of a Thermoelectric Nanomaterial through THz Spectroscopy

Michaela S. Koller

Macalester College, mkoller@macalester.edu

James Heyman

Macalester College, heyman@macalester.edu

Gunnar Footh

Macalester College, gfooth@macalester.edu

Abstract

In today's society there is a great demand on energy output—in the United States alone we rely heavily on non-renewable energy sources. Thermoelectric materials may be able to be used to create more efficient energy systems or recover wasted heat from inefficient technologies. This paper focuses on the conductivity of a new thermoelectric material that incorporates copper into a tellurium nanowire PEDOT:PSS material. The addition of copper seems to increase the conductivity of the material, although the exact relationship between the percentage of copper to tellurium and its affect on the conductivity is uncertain from the results.

Follow this and additional works at: <http://digitalcommons.macalester.edu/mjpa>

 Part of the [Atomic, Molecular and Optical Physics Commons](#), and the [Optics Commons](#)

Recommended Citation

Koller, Michaela S.; Heyman, James; and Footh, Gunnar (2017) "Conductivity Measurements of a Thermoelectric Nanomaterial through THz Spectroscopy," *Macalester Journal of Physics and Astronomy*: Vol. 5 : Iss. 1 , Article 4.

Available at: <http://digitalcommons.macalester.edu/mjpa/vol5/iss1/4>

This Capstone is brought to you for free and open access by the Physics and Astronomy Department at DigitalCommons@Macalester College. It has been accepted for inclusion in Macalester Journal of Physics and Astronomy by an authorized editor of DigitalCommons@Macalester College. For more information, please contact scholarpub@macalester.edu.

 MACALESTER COLLEGE

Conductivity Measurements of a Thermoelectric Nanomaterial through THz Spectroscopy

Cover Page Footnote

James Heyman advised me on this project and Gunnar Footh was my lab partner in this experiment.

I. Introduction

In today's society, there is a great demand on energy output—in the United States alone we rely heavily on non-renewable energy sources. Earth only has a finite supply of resources such as oil, gas, and coal, and we have increasingly begun to worry about climate change due to the release of CO₂ emissions. Given how much we rely on energy in our daily lives, it is important to make use of more sustainable energy sources, as well as create more efficient systems. One of the ways we can do this is by utilising thermoelectric materials.

Thermoelectric materials are able to convert heat energy into an electric potential or visa versa. When a temperature difference is changed into electrical energy it is called the Seebeck effect. Many of our current technologies are inefficient and produce heat as a by-product of the processes present, but the Seebeck effect may allow us to utilise this wasted heat and recycle some of the energy. Currently thermoelectric materials are expensive and inefficient; they are only used in projects where their cost is fractional to that of the project and will be too remote to access easily for repairs. For example, in NASA spacecrafts, radioisotope thermoelectric generators have been used in missions to Mars [1]. Thermoelectrics need to become more efficient in order to be competitive enough for the market.

The efficiency of a thermoelectric material is related to the figure of merit, ZT , which is defined as follows:

$$ZT = \frac{\sigma S^2 T}{\kappa}, \quad (1)$$

where σ is the electrical conductivity, S is the Seebeck coefficient, κ is the thermal conductivity, and T is the absolute temperature. The figure of merit relates to the efficiency of a thermoelectric material—a higher figure of merit means the material more efficiently produces electricity. When discussing heat engines, it is useful to

compare efficiencies to the Carnot efficiency, which establishes a theoretical limit for the maximum efficiency of a system that runs with respect to temperature differences. Current ZT values for marketable thermoelectric materials are about 1—which is low, and thermoelectric generators have a conversion efficiency of only around 5%. In order to be competitive with traditional energy systems, the ZT values need to be 2 to 3 [2]. With a temperature difference of around 470 K and a ZT of 3 would have an efficiency of about 50% of the Carnot efficiency – which would be competitive in today’s market, if it could be produced cheaply. One of the ways to improve efficiency is to create materials with higher electrical conductivities and/or lower thermal conductivities.

Tellurium Copper Nanowire Poly(3,4-ethylenedioxythiophene) polystyrene sulfonate (tellurium-copper nanowire PEDOT:PSS) is a material that was created to explore a potentially more efficient thermoelectric, as the properties of each constituent were combined in such a way as to maximise their strengths. PEDOT:PSS is a conducting polymer which is commonly known for having a low thermal conductivity (κ) but a good electrical conductivity (σ) and Seebeck coefficient (S). Tellurium is an element with a high Seebeck coefficient as well as high electrical and thermal conductivities. Copper is a metal that has a very high electrical conductivity, but it also has a good thermal conductivity. In order to try and increase the electrical conductivity, σ , of PEDOT:PSS without significantly increasing the thermal conductivity, κ , Edward Zaia from the Berkeley Laboratory, created solution deposited samples of tellurium-copper alloy nanowires and PEDOT:PSS thin films on silicon. Theoretically, the space between the nanowires should make it more difficult for heat to diffuse through the material, without losing the benefit of the high electrical conductivities and Seebeck coefficients from the copper and tellurium. Our

question in this research was two-fold: does adding a metal to a thermoelectric nanomaterial increase its efficiency?, and if so, what is the relationship between higher copper percentages in the nanowire and the sample's electrical conductivity?

II. Methodology

Edward Zaia and Dr. Jeffry Urban from the Lawrence Berkeley National Laboratory provided the research samples. The samples themselves were shiny, silver in colouring, and non-uniform. In this case, non-uniform is referring to inconsistencies such as scratches, different textures, and an unevenness of the surface itself. While some of these discrepancies occurred due to general difficulties in handling the samples, most of them had to do with problems that occur when creating solution deposited slides, as there is a certain lack of control over the substance in the creation process. In order to study the same site on each sample individually, we used a scalpel blade attached to a micromanipulator under a microscope to electrically isolate a 2 mm by 2 mm square. When choosing a location for electrical isolation we sought out the area on the sample that appeared the most homogeneous (seen in Figure 1). We also used cotton buds to clear a section of the sample from the silicon base to create a reference area on each sample.

We had a total of thirty samples over the course of our research. We started with twenty-four samples, twelve of which had varying levels of copper concentration in the tellurium-copper alloy in the nanowires; we were fortunate to have duplicates of every sample, so from each pair of samples, we chose to take our measurements on whichever sample we could find the most homogeneous region. After our initial results we were sent six more samples on silicon bases: two sets of three varying percentages of copper. We repeated all measurements on each of these six samples.

In order to determine the samples' electrical conductivity, we took two types of measurements: direct current (DC) and optical (AC). For DC measurements, we took 4-wire DC conductivity measurements of the samples using a Cascade Microtech probe station and Keithley 2400 Source Measure Unit. We attached the four connectors just inside of the corners of each of the electrically isolated squares mentioned earlier, and read the 2D resistivity of each of our samples. The resistivity is related to the conductivity in the following way:

$$\sigma = \frac{1}{\rho}, \quad (2)$$

where σ is the conductivity and ρ is the resistivity. We took film thickness measurements using the Atomic Force Microscope (AFM) at multiple points at the edges of each 2mm x 2mm electrically isolated square. By averaging the readings for each sample, we estimated the thickness of each film and used this to determine the three-dimensional DC conductivity of each sample. The cumulation of the estimated thicknesses, the measured resistivity's, and the calculated three-dimensional DC conductivities can be found in Table 1.

We then took optical THz-frequency conductivity measurements as a function of frequency using a Time-Domain Terahertz Spectrometer. This consisted of a Femtosecond Ti-Sapphire laser (FemtoLasers FemtoCompact) with a biased photoconductive THz source and an electro-optic THz detector (Figure 2). This laser system emits a femtosecond laser beam, which splits into two different beams at a beam splitter: a THz beam and a probe pulse. The THz beam is created by an emitter when fast pulses of waves produced by the Ti Sapphire system close the circuit a photoconductive switch, which forces current to flow, ultimately creating an electromagnetic pulse. The THz pulse is then focused, using mirrors, on the sample; the sample reflects and absorbs some of the energy, but the rest of this pulse will pass

through the sample. This pulse changes, which is measured by comparing it to the beam that does not pass through the sample (the probe pulse) by optically re-focusing it onto a detector. While the THz beam passes through the sample, the probe pulse simultaneously goes to a delay stage and then goes to the detector crystal where it samples the electric field. The electric field changes the index of refraction of the detector crystal through the electro-optic effect. The change in polarisation of the probe pulse is then measured.

To take optical conductivity measurements of our samples we made use of both the electrically isolated squares as well as the aforementioned reference areas. We took measurements such that the THz beam was focused inside of the 2mm x 2mm electrically isolated square and then we moved the beam to focus on the area of the sample where the tellurium-copper NW PEDOT:PSS had been removed from the silicon backing.

III. Results and Discussion

Our DC measurements were relatively low for all of our readings from the first batch of samples, ranging from about 0.9 S/cm for a medium loaded copper sample (111015 30B) to 17.5 S/cm for a high loaded copper sample (111015 150A) (in SI base units, S is $\text{kg}^{-1}\text{m}^{-2}\text{s}^3\text{A}^2$). These values represent some of the lowest and highest conductivity values from our samples. The AC measurements were much higher than their DC counterparts. For 111015 30B the AC measurement was 65.1 S/cm, while it was 246.3 S/cm for 111015 150A. Looking at the both the DC and AC measurements, it is also clear that as the copper loading increases, both the DC and AC conductivities increase (Table 1 and Figure 3). The AC measurements were on the order of two to three orders of magnitude larger than their DC counterparts, but if

our samples were perfect, these measurements should have been the same. We expected this sort of discrepancy because of the technique used to measure the DC conductivity of the samples. The four-wire conductivity measurement is extremely sensitive to any defects on the surface of a sample, and our samples were far from homogeneous and were sometimes damaged. Any minor crack or defect in the area of the film we studied would decrease any DC reading significantly. That was why we also took the AC measurements we did, as the film defects would not affect the measurements taken via THz spectroscopy.

The AC results produced both real and imaginary conductivities for the samples (Figures 4, 5, and 6). The real conductivity is measured as the current that is in phase with the voltage while the imaginary conductivity is out of phase by 90 degrees. We focused on the real conductivity recorded. The AC readings showed that the samples with copper present had higher conductivity measurements than those without, and that frequency affects the conductivity, which is shown in Figures 4, 5, and 6. For example, for at 2 THz, the conductivity of the sample without copper (071516 0A) is around 200 S/cm, whereas the for the medium loaded sample (071516 40A) it is just about 1500 S/cm. Figure 5 also shows that as the frequency increases, the conductivity for 071516 40A changes. For example, at 1 THz, the conductivity is around 250 S/cm, and at 1.5 THz the conductivity is closer to 1300 S/cm. This upward trend is not continued however, as after around 2 THz the conductivity of the sample begins to decrease.

After taking the DC and AC measurements of the first batch of samples, we shared our results with the lab at Berkeley who prepared the samples, and found our DC measurements were lower than those taken before the samples were sent to us.

The lab created a new set of samples so that we could re-take measurements and test if atmospheric exposure may have contributed to the low DC values we had measured. When the new samples arrived, we left one sample out and measured its surface resistivity over a period of four hours and saw an immediate increase after atmospheric exposure (Figure 7). This shows that our first set of results (seen in Figure 3) is slightly less reliable than our second set (seen in Figure 8), as the first batch of samples had a significant amount of atmospheric exposure. We re-took all our DC and AC measurements on the second batch of samples.

Similarly to our first batch, all of the DC conductivities were suppressed in comparison to their AC conductivities. However, in our first batch there was a clear trend that the higher the copper percentage in the nanowires, the higher the DC and AC conductivity. This does not remain true for the conductivities of the second batch. Unsurprisingly, one of the samples with no copper had the lowest AC conductivity of the group (at 200 S/cm at 2 THz), but the medium loaded copper sample seemed to have the highest conductivity (at around 1700 S/cm at 2 THz). If our results had followed the original trend, the highest conductivity should have been the higher-loaded copper sample, but this is not the case, which can be clearly seen in Figure 8. For both Series A and B, the DC conductivity for the medium loaded sample is lowest in the set of three copper-concentrations, which also disrupts the trend of conductivity generally increasing with higher copper concentrations. This may indicate that the medium loaded sample has interesting properties that should be studied further, as it may be the sweet spot for the highest conductivities.

IV. Summary and Conclusions

In this research project, we set out to study a new thermoelectric material. We wanted to know how the addition of copper in a tellurium nanowire in PEDOT:PSS would affect the material's electrical conductivity. It is clear from our results that the addition of copper to the tellurium nanowires in the PEDOT:PSS material does increase the materials' electrical conductivity (Figure 8). Samples with copper concentration showed a clearly higher AC conductivity than the samples without copper loading. In addition, all samples showed a THz AC conductivity one to three orders of magnitude larger than the DC counterpart. Exposure to air degraded the DC conductivity without strongly affecting the THz conductivity. Overall, the low DC conductivities are not surprising given how in-homogeneous the samples we worked with were. Our results for DC and AC measurements of our medium loaded copper samples from our second batch of samples did not clearly fit any trends that we expected. This is very interesting; in the future it may be optimal to take further tests on tellurium-copper nanowire PEDOT:PSS that have copper concentrations similar to our medium-loaded samples 071516 40A and 40B.

References:

[1] NASA.

<https://mars.nasa.gov/msl/mission/technology/technologiesofbroadbenefit/power/>

[2] Z.-G. Chen, G. Han, L. Yang, L. Cheng, and J. Zou, Progress in Natural Science: Materials International 22, 535 (2012).

Name	d (nm)	Δd (nm)	R_{2D} (Ω)	σ (S/cm) DC	Average Values around 2 THz	
					σ' (S/cm) THz	σ'' (S/cm) THz
111015 0A	93	28	5.10E+04	2.1		
111015 0B	334	93	4.81E+03	6.2	67.6	-16.8
111015 2A	225	41	2.95E+04	1.5	44.0	-16.6
111015 4A	121	26	4.14E+04	2.0	53.3	89.8
111015 7A	204	34	3.52E+04	1.4	55.3	-21.6
111015 11A	248	50	2.89E+04	1.4	39.7	-3.5
111015 15A	390	40	1.65E+04	1.6	59.9	-25.7
111015 30B	286	53	3.81E+04	0.9	65.1	-63.2
111015 40A	248	124	2.15E+04	1.9	71.2	-12.9
111015 60A	75	16				
111015 80A	126	41	3.00E+04	2.6	98.4	-38.9
111015 100B	765	368	3.09E+03	4.2	96.8	-115.3
111015 150A	685	156	8.36E+02	17.5	246.3	-106.2

Table 1: A table of film thicknesses and uncertainties, the 2D resistivity measurements, the 3D DC conductivities, and AC real and imaginary conductivities of the samples from the first batch of samples. The higher the label value the higher the copper concentration in the tellurium copper alloy nanowires. (For example, 0A has no copper loading, while 150A has 42% copper loading.) Some boxes are left blank as we were unable to clearly measure the conductivities from these samples.



Figure 1: This is an image of one of our samples. It shows how inhomogeneous our sample surfaces were. It also shows one of the electrically isolated squares and reference areas.

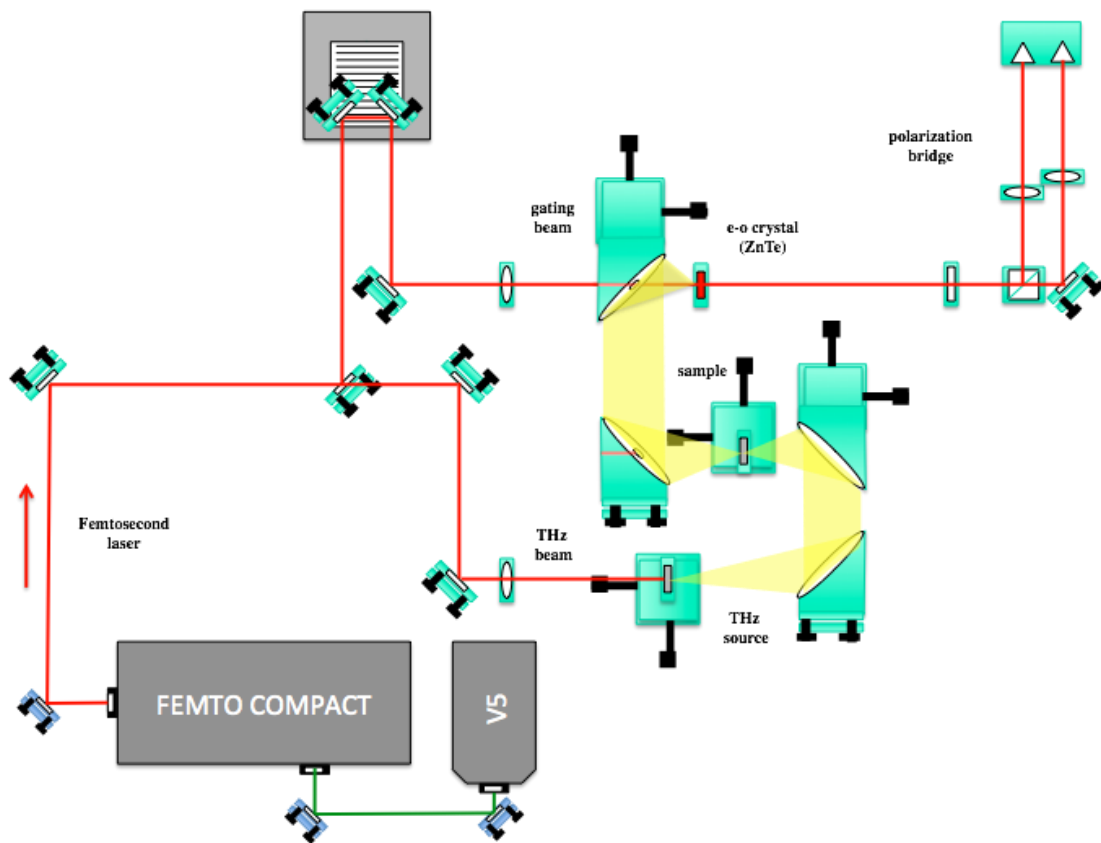

Figure 2: A diagram of the Macalester Ti-Sapphire laser optical experiment setup representation.

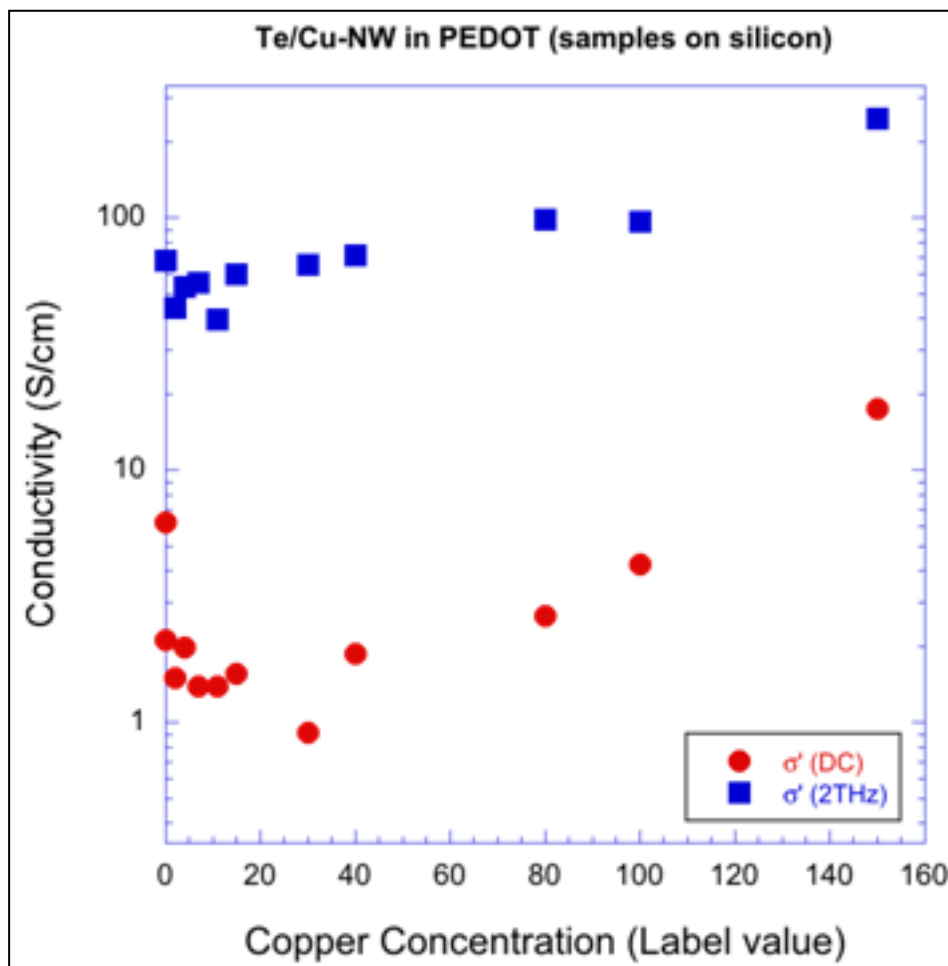

Figure 3: This graph shows the AC (blue) and DC (red) conductivities of the first batch of samples. On the y-axis we have conductivity as a logarithmic scale. The x-axis represents the numeric label assigned to each sample from the group at Berkeley that created them. The higher the label value the higher the concentration of copper in the nanowires.

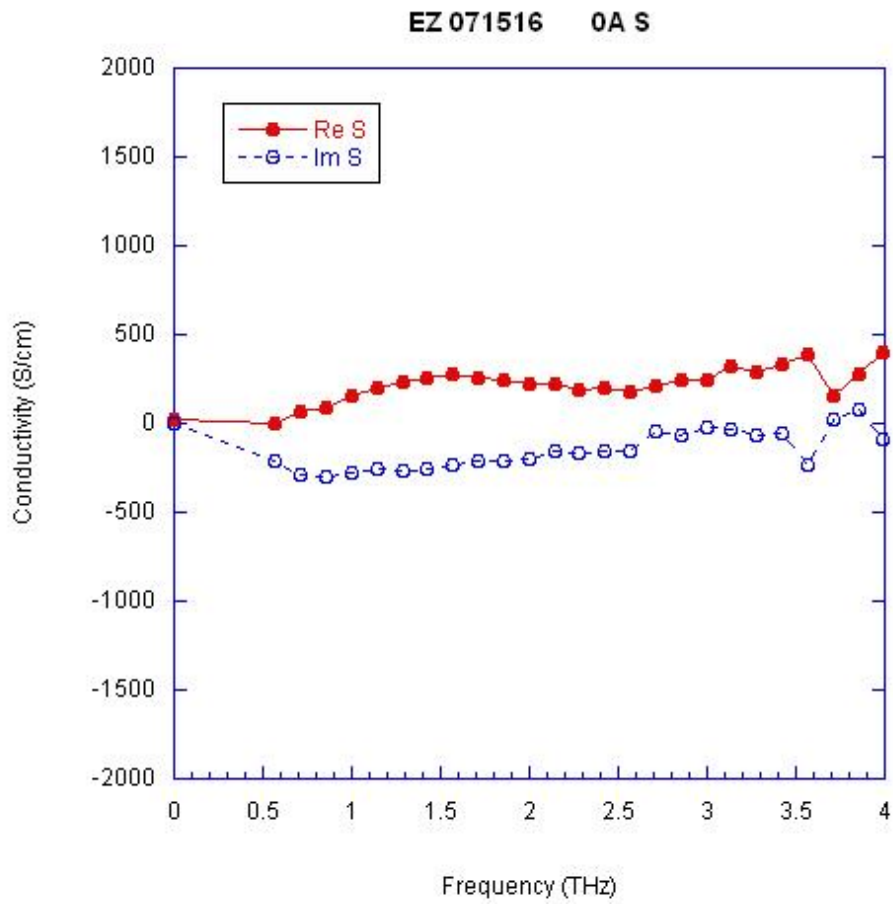

Figure 4: This shows the AC conductivity of the zero-copper loaded sample. The laser system was unable to read a conductivity at 0 THz, so the value at 0 THz was the DC conductivity for this sample.

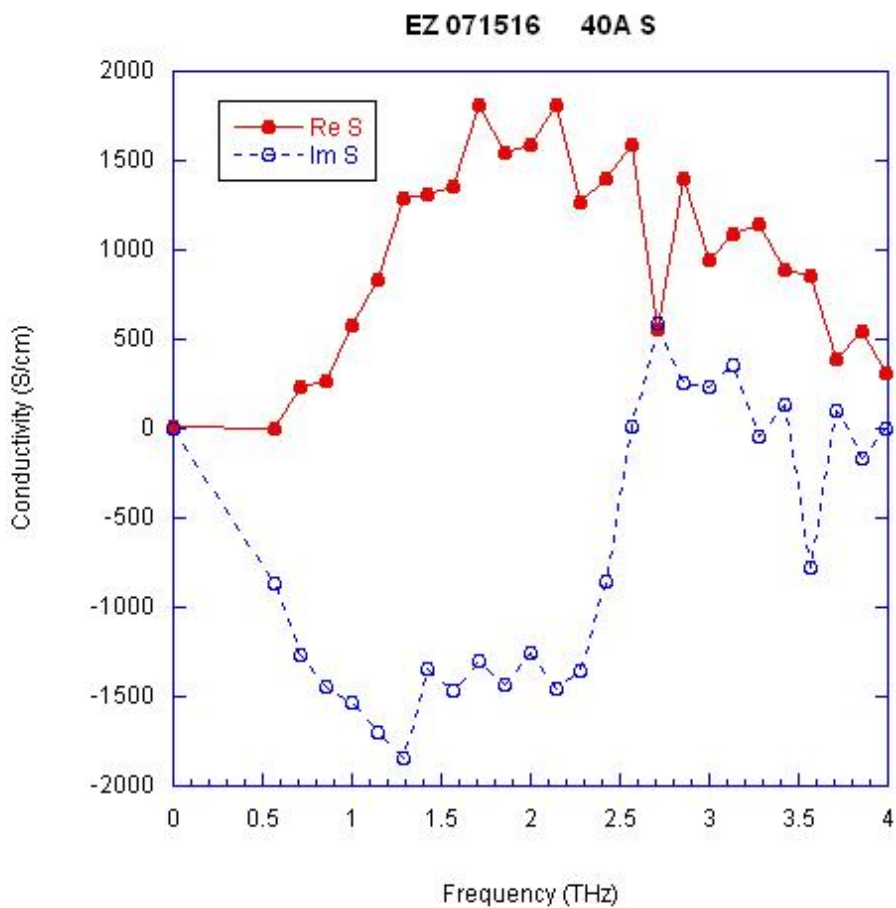

Figure 5: This shows the AC conductivity of the medium loaded copper sample. The laser system was unable to read a conductivity at 0 THz, so the value at 0 THz was the DC conductivity for this sample.

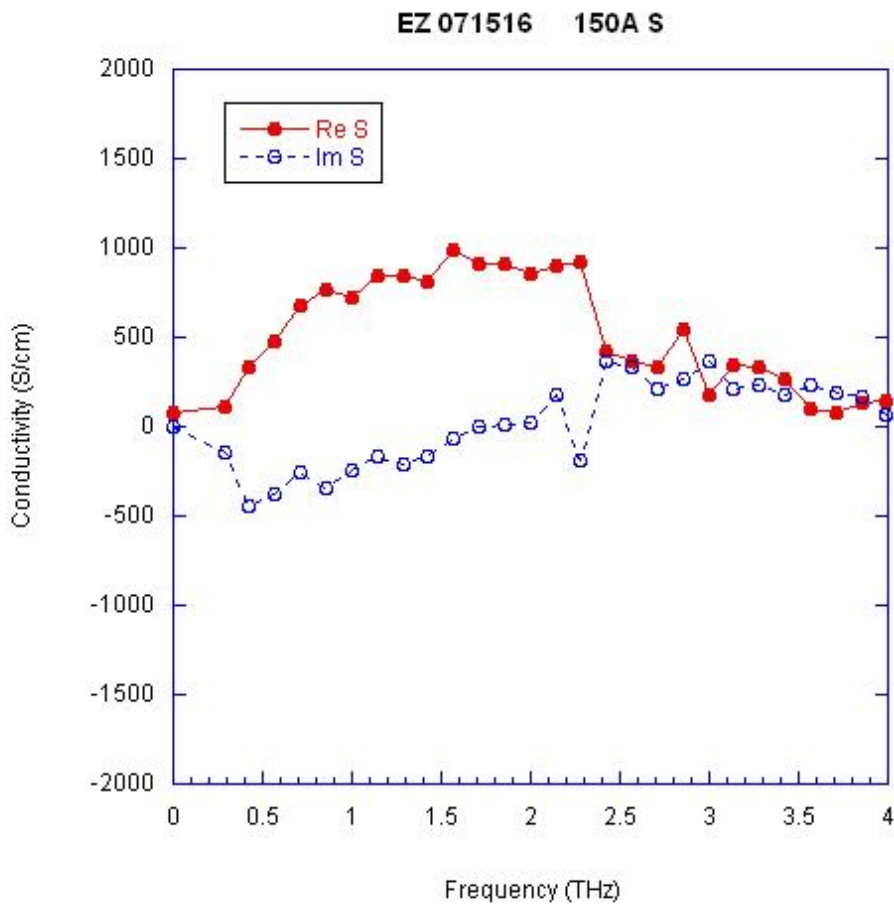

Figure 6: This shows the AC conductivity of the high loaded copper sample. The laser system was unable to read a conductivity at 0 THz, so the value at 0 THz was the DC conductivity for this sample.

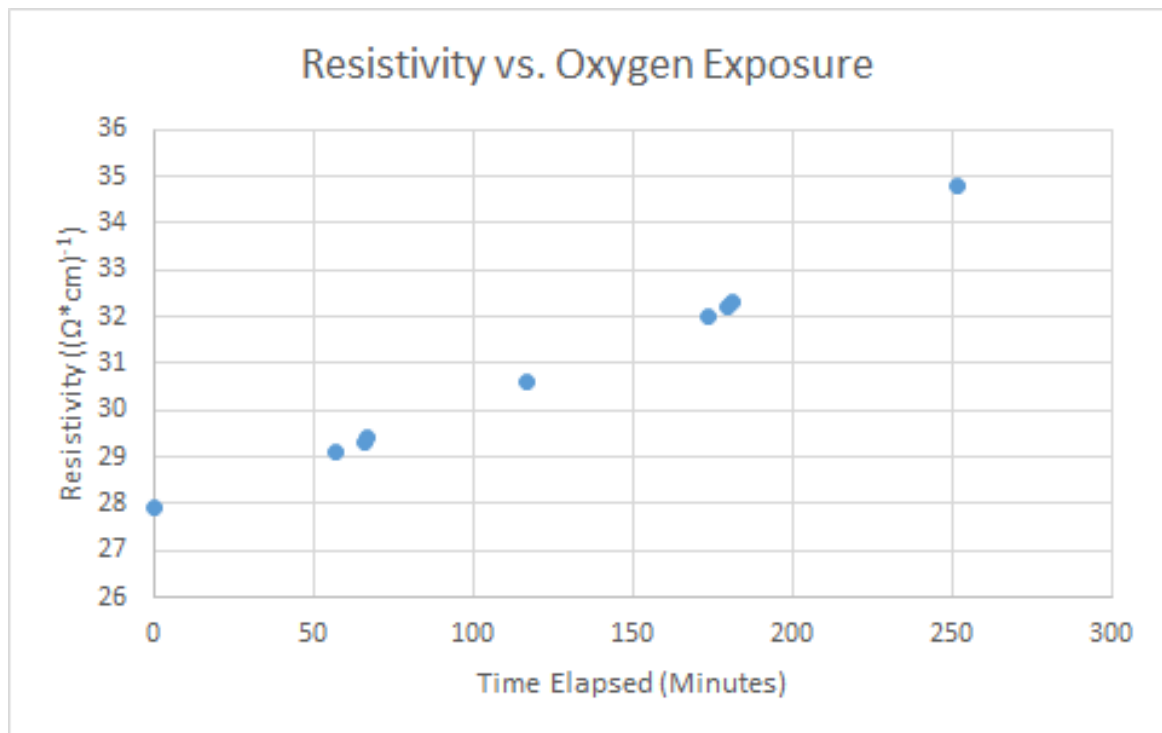

Figure 7: This graph shows the resistivity of a sample that is being exposed to the atmosphere over time. The increase in resistivity means that the conductivity of the sample is decreasing.

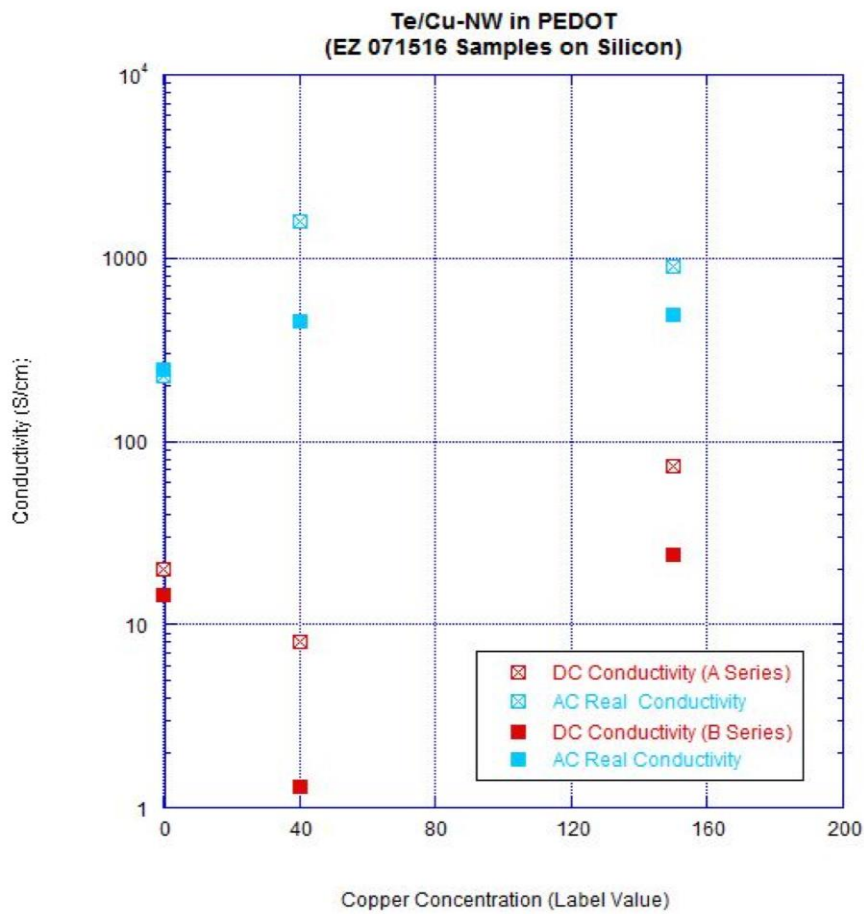

Figure 8: This graph shows the AC (blue) and DC (red) conductivities of the second batch of samples. The crosses are for series A while the filled in squares are for series B. On the y-axis we have conductivity as a logarithmic scale. The x-axis represents the numeric label assigned to each sample.