

Technical University of Denmark



Improved Decoupling for 13C coil Arrays Using Non-Conventional Matching and Preamplifier Impedance

Sanchez, Juan Diego; Johansen, Daniel Højrup; Hansen, Rie Beck; Hansen, Esben S. ; Laustsen, Christoffer; Zhurbenko, Vitaliy; Ardenkjær-Larsen, Jan Henrik

Publication date:
2017

Document Version
Publisher's PDF, also known as Version of record

[Link back to DTU Orbit](#)

Citation (APA):
Sanchez, J. D., Johansen, D. H., Hansen, R. B., Hansen, E. S., Laustsen, C., Zhurbenko, V., & Ardenkjær-Larsen, J. H. (2017). Improved Decoupling for 13C coil Arrays Using Non-Conventional Matching and Preamplifier Impedance. Abstract from ISMRM 25th Annual Meeting & Exhibition, Honolulu, United States.

DTU Library

Technical Information Center of Denmark

General rights

Copyright and moral rights for the publications made accessible in the public portal are retained by the authors and/or other copyright owners and it is a condition of accessing publications that users recognise and abide by the legal requirements associated with these rights.

- Users may download and print one copy of any publication from the public portal for the purpose of private study or research.
- You may not further distribute the material or use it for any profit-making activity or commercial gain
- You may freely distribute the URL identifying the publication in the public portal

If you believe that this document breaches copyright please contact us providing details, and we will remove access to the work immediately and investigate your claim.

Improved Decoupling for ^{13}C coil Arrays Using Non-Conventional Matching and Preamplifier Impedance

Juan D. Sanchez-Heredia¹; Daniel Højrup Johansen¹, Rie Beck Hansen¹, Esben S. Hansen²; Christoffer Laustsen²; Vitaliy Zhurbenko¹; Jan H. Ardenkjær-Larsen¹,

¹Technical University of Denmark, Department of Electrical Engineering, Ørstedes Plads, 2800 Kgs. Lyngby, Denmark.

²Aarhus University, Department of Clinical Medicine, Palle Juul-Jensens Boulevard 99, 8200 Aarhus, Denmark

Synopsis (100 Words):

In this study, we describe a method to obtain improved preamplifier decoupling for receive-only coils. The method relies on the better decoupling obtained when coils are matched to an impedance higher than 50 Ω . Preamplifiers with inductive imaginary impedance and low real impedance, increase the effectiveness of the decoupling. A 2-channel ^{13}C array of 50 mm loop coils show an increase of Q-factor of the coils from 247 to 365. The measured SNR, using two small phantoms, demonstrated a similar improvement.

Purpose:

Arrays of small coils are challenging due to the low sample loading (high Q) and strong coupling between elements, and the difficulty of decoupling them without compromising the Q-factors of the individual coils. Preamplifier decoupling as described in¹ (and further developed in²) can potentially overcome the problem, but for high-Q coils, a very low input impedance is needed in order to obtain a reasonable decoupling. However, for the case of ^{13}C at 3 T (32.13 MHz), commercially available preamplifiers³ have input impedance over 2.5 Ω , which for high-Q coils (>300) provide very modest decoupling (<13 dB) in the standard configuration.

Here we show that matching the coils to a higher impedance than the noise-optimum of the preamp (usually 50 Ω) can be beneficial to improve the decoupling. The effect can be improved even more, if the preamplifier shows an inductive impedance at its input (with low real part).

Methods:

A modification of the circuit proposed in² is used, in combination with the active decoupling scheme proposed in⁴ (Fig. 1). This circuit allows keeping the active decoupling from the transmitter independent of the inductance used for the preamplifier decoupling (L_3), which is practical when the preamplifier decoupling needs to be finely tuned (as is the case in high Q coils).

A 2-channel array was built (Fig.2), using wire loop coils (coil diameter 50 mm, wire diameter 2.3 mm) separated by 75 mm (corresponding to next near neighbors in an overlapped array). The preamp decoupling performance was measured as the difference of S_{12} [dB] of a loosely coupled double-loop probe between the 50 Ω and the preamplifier load. The Q-factor of the coils when mounted in the array was measured from the S_{11} . Experiments were repeated using a commercial preamplifier with resistive low input impedance (WMA32C, WanTCom, Chanhassen, MN, USA) matched to 50 and 100 Ω , and a self-made preamplifier (more details in a separate abstract) with an inductive input impedance and matched to 50 Ω . The parameters of the preamplifiers are shown in Table 1. Imaging experiments were performed at a clinical 3 T scanner (Signa HDx, GE Healthcare, Waukesha, WI, USA) using two spherical (38 mm diameter) ^{13}C -enriched bicarbonate phantoms, placed one on top of each coil and separated 1 mm from them. The sequence used was a regular CSI with 16x16 acquired points, 19 s duration, and FOV of 120x120x50 mm³.

Results:

The measured coil Q-factor and maximum SNR are summarized in Table 1, while the decoupling is shown in Fig. 3, for the 3 different preamplifier configurations tested. The obtained Q-factor for the different configurations is consistent with the measured decoupling. The better Q of the coils translates to better measured SNR, which shows that the coils are working on the coil-noise dominated domain.

Discussion:

Non-conventional coil matching can provide better preamplifier decoupling when using the circuit proposed in [2], and can be used to obtain better SNR as long as the noise figure of the preamplifiers is still good at the impedance chosen for matching. In this study, we show that matching to a higher impedance using traditional low input impedance preamplifiers improves the preamplifier decoupling and can be beneficial in terms of SNR for coils where thermal noise is dominant, due to the improved Q-factor of the coils. This effect can be exploited even further, if the preamplifier presents an inductive input impedance, therefore allowing the matching with a higher capacitance value (C_M in Fig.1). This is so, because at the frequency of interest, the impedance of the matching network (Z_{MATCH}) becomes a bandpass filter when the preamp is connected. This creates a current divider with the resonator formed by the loop and C_T . Therefore, the amount of current reduction in the loop is inversely proportional to Z_{MATCH} (being Z_{MATCH} lower when the coil is matched to a higher impedance [2]).

Conclusion:

A practical setup providing improved decoupling for ^{13}C coils at 3 T has been demonstrated on a 2-channel array of small coils. An improvement of 30 % on the maximum measured SNR was found when matching the coils to a slightly higher impedance (100 Ω) with commercial preamplifiers. An even higher, 60 %, improvement was obtained with the use of preamplifiers with inductive input impedance. This decoupling method is of particular interest for arrays of small coils and/or low frequency, where coil noise dominates, and the coupling between elements is a major source of electronic noise.

References:

- [1]. Roemer, Peter B., et al. "The NMR phased array." *Magnetic resonance in medicine* 16.2 (1990): 192-225.
- [2]. Reykowski, Arne, Steven M. Wright, and Jay R. Porter. "Design of matching networks for low noise preamplifiers." *Magnetic resonance in medicine* 33.6 (1995): 848-852.
- [3]. WanTcom Inc. WMA32C Datasheet. (2013).
- [4]. Sanchez-Heredia, Juan D., et al. "Decoupling Scheme for a Cryogenic Rx-Only RF Coil for ^{13}C Imaging at 3T." ISMRM 2016 Annual Meeting & Exhibition. 2016.

TABLE 1. DIFFERENT CONFIGURATIONS OF PREAMPLIFIER AND MATCHING IMPEDANCE, AND MEASURED RESULTS.

Configuration	Preamp Input Impedance [Ω]	Coil Matching Impedance [Ω]	Preamp Noise Figure [dB]	Coil $Q_{UNLOADED}$	SNR_{max}
1	$2.5 + j0$	50	0.55	247	162
2	$2.5 + j0$	100	0.82	292	197
3	$0.4 + j67$	50	0.76	365	264

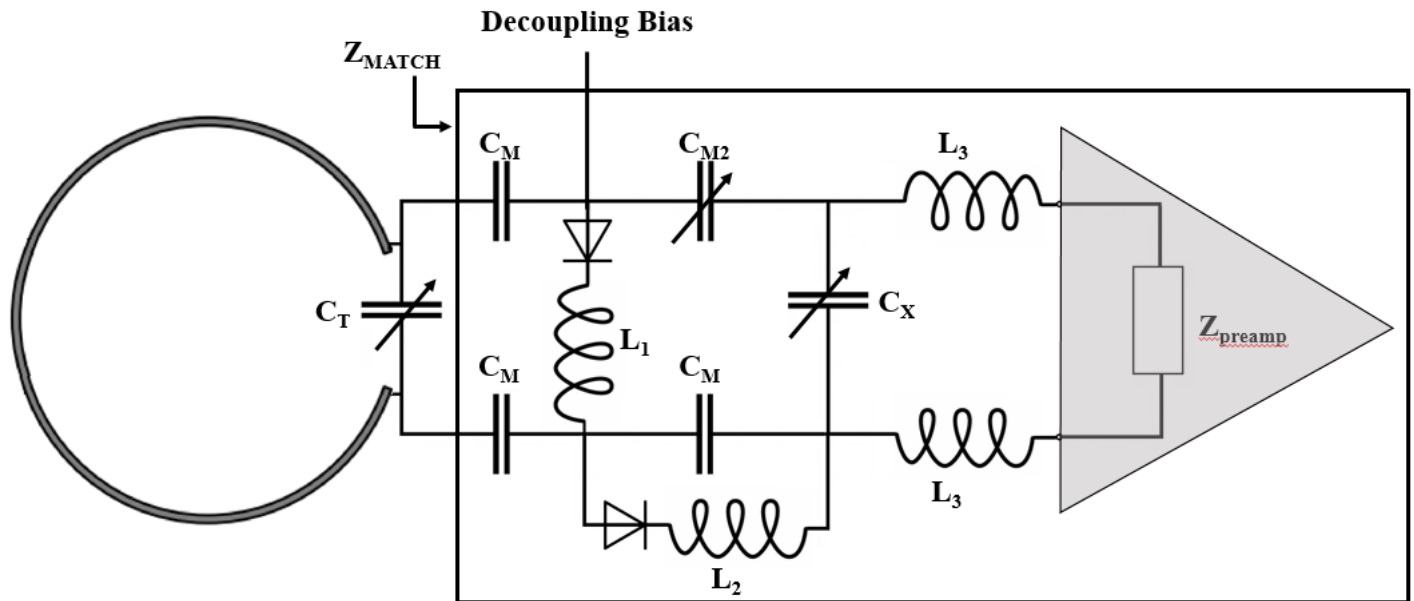

Figure 1. Circuit used to tune and match the coils. Adding trimmers in parallel to the capacitances C_T , C_{M2} and C_X allows to fine tune independently the resonance frequency of the coil, the matching and the preamplifier decoupling respectively. The active decoupling from the transmitter is tuned with the inductors L_1 and L_2 . The values used for the lumped elements are: $C_T \approx 230$ pF, $C_M = 47$ pF, $C_{M2} = 10-40$ pF, $L_1 = 1000$ nH, $L_2 = 520$ nH, $C_X = 15-80$ pF and $L_3 = 150$ nH. Z_{MATCH} is the equivalent impedance of the whole matching network.

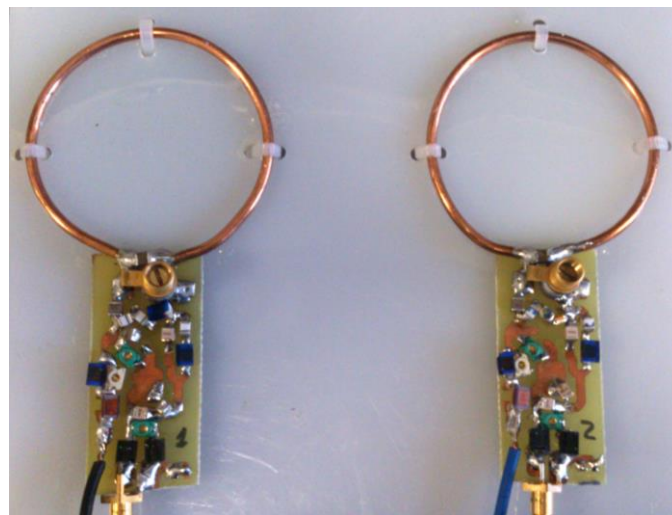

Figure 2. Fabricated 2 channel array. The loops are made with copper wire of 2.3 mm thickness and have 50 mm of diameter. The centers of the loops are separated 75 mm.

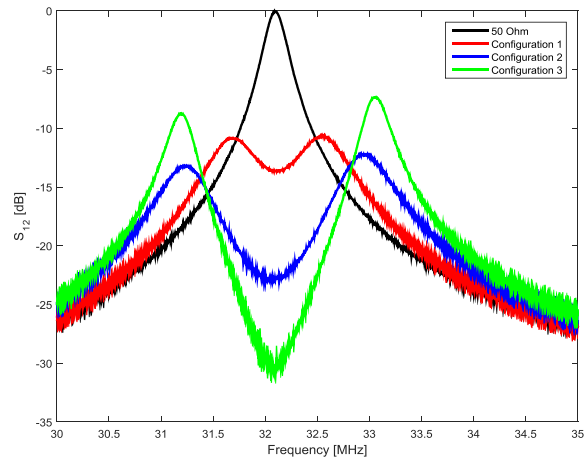

Figure 3. Pre-amplifier decoupling measured for one of the coils with a loosely coupled double-loop probe.

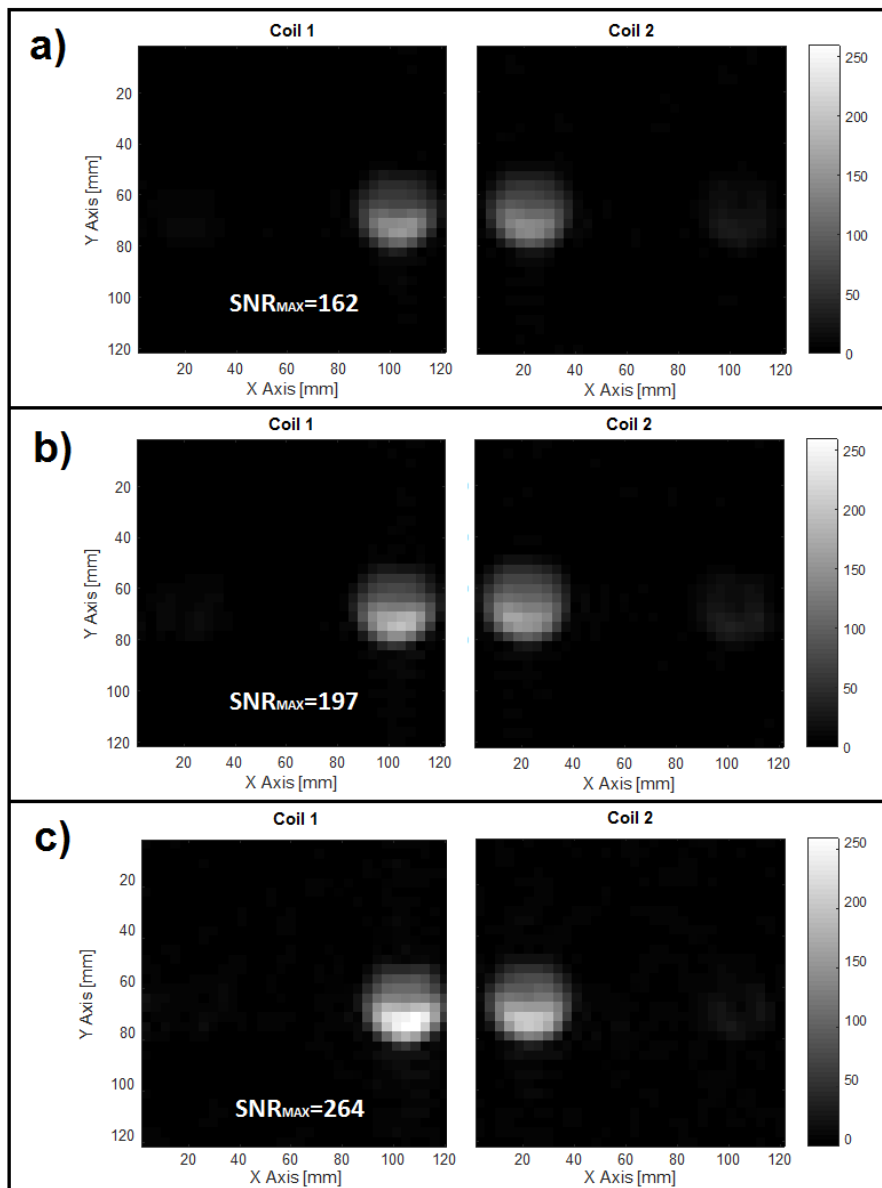

Figure 4. Measured SNR obtained with the 2-channel array under the 3 different configurations. a) Configuration 1, b) Configuration 2 and c) Configuration 3.