

Technical University of Denmark



Microstrip Resonator for High Field MRI with Capacitor-Segmented Strip and Ground Plane

Zhurbenko, Vitaliy; Boer, Vincent ; Petersen, Esben Thade

Published in:

Proceedings of the International Society for Magnetic Resonance in Medicine

Publication date:
2017

Document Version
Peer reviewed version

[Link back to DTU Orbit](#)

Citation (APA):

Zhurbenko, V., Boer, V., & Petersen, E. T. (2017). Microstrip Resonator for High Field MRI with Capacitor-Segmented Strip and Ground Plane. In Proceedings of the International Society for Magnetic Resonance in Medicine

DTU Library
Technical Information Center of Denmark

General rights

Copyright and moral rights for the publications made accessible in the public portal are retained by the authors and/or other copyright owners and it is a condition of accessing publications that users recognise and abide by the legal requirements associated with these rights.

- Users may download and print one copy of any publication from the public portal for the purpose of private study or research.
- You may not further distribute the material or use it for any profit-making activity or commercial gain
- You may freely distribute the URL identifying the publication in the public portal

If you believe that this document breaches copyright please contact us providing details, and we will remove access to the work immediately and investigate your claim.

Microstrip Resonator for High Field MRI with Capacitor-Segmented Strip and Ground Plane

Vitaliy Zhurbenko⁽¹⁾, Vincent Boer⁽²⁾, Esben Thade Petersen^(1,2)

(1) Technical University of Denmark, 2800 Kgs. Lyngby, Denmark

(2) Danish Research Centre for Magnetic Resonance, Centre for Functional and Diagnostic Imaging and Research, Copenhagen University Hospital, Hvidovre, Denmark

Synopsis: High field MRI coils are often based on transmission line resonators. Due to relatively short wavelength of RF fields, such coils produce uneven field patterns. Here we show, that it is possible to manipulate magnetic field patterns of microstrip resonators in both planes (sagittal and transverse) segmenting stripe and ground plane of the resonator with series capacitors. The design equations for capacitors providing symmetric current distribution are derived. The performance of two types of segmented resonators are investigated experimentally. To authors' knowledge, a microstrip resonator, where both, strip and ground plane are capacitor-segmented, is shown here for the first time.

Purpose: To increase sagittal and transverse uniformity of the magnetic field in transmission line resonators. An efficient circuit model allowing to design segmented resonators with symmetric current distribution is developed. The described approach to control magnetic field would be useful in the design of coils with uniform field patterns.

Background: For the purpose of boosting the efficiency of transmission line coils they are usually operated as resonators. This results in a large standing wave ratio (SWR) on the line. To minimize that, coils based on transmission line resonators are typically shorter than half a wavelength and proper capacitive loading is used to achieve symmetric current distribution along the line¹. The resulting current magnitude reduces at the ends of the line due to destructive interference of the incident and reflected electromagnetic waves, as it is shown in Fig. 1 (red dotted curve). It is, however, preferable to have a uniform current distribution. That would result in a more uniform magnetic field in the sagittal plane. Uniform current distribution could be achieved by either segmenting the microstrip with series capacitors², or using zeroth order resonance³. The advantage of both approaches is that they allow to build resonators of arbitrary length^{3,4}. A uniform current distribution along the resonator, however, does not guarantee the uniformity of the field in the transverse plane. The field distribution in the transverse plane, on the other hand, can be manipulated by segmenting the ground plane of the microstrip resonator⁵.

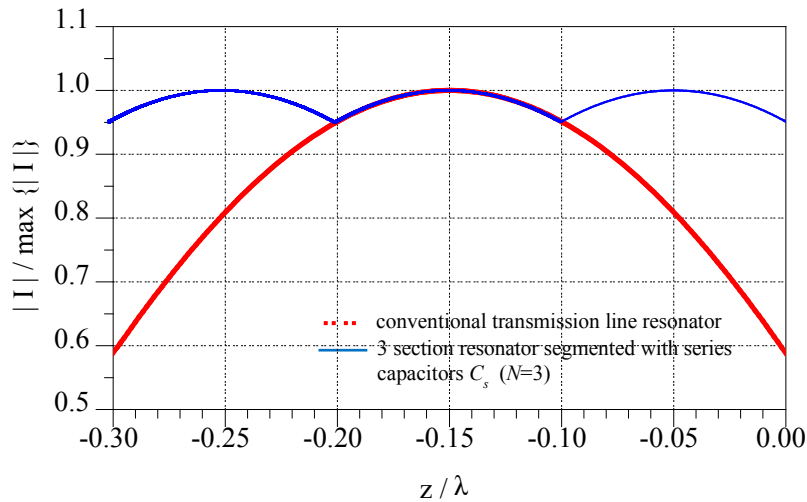

Fig.1. Normalized magnitude of the current distribution for conventional transmission line resonator and resonators in Fig. 2.

Methods: The considerations above suggest that in order to improve field uniformity in both sagittal and transverse planes, both conductors, strip and ground plane, of the microstrip line have to be segmented. A circuit model of such a structure is shown in Fig. 2. (b). Series capacitors C_s are inserted in both current-carrying conductors unlike the case shown in Fig. 2. (a)², where only the stripe is segmented.

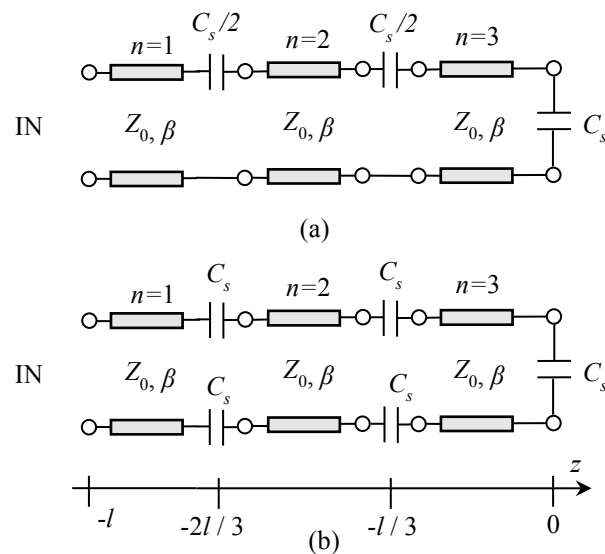

Fig.2. Circuit model of a transmission line resonator where (a) – one conductor or (b) – both conductors are segmented with series capacitors C_s . Here z is the longitudinal coordinate, l is the total length of the resonator, n is the section number, β is the phase constant; Z_0 is the characteristic impedance.

These capacitors can compensate for self-inductance of the transmission line by introducing opposite phase shift. Imposing a symmetry condition for current distribution we will achieve identical currents in both cases (Fig. 2) if the series capacitors are chosen in the following way:

$$C_s = \frac{\sin(\beta l/N)}{2\pi f_0 Z_0 (1 - \cos(\beta l/N))} \quad , \quad (1)$$

where l is the total length of the segmented transmission line resonator; N is the number of segments after inserting series capacitors (in this example, using two series capacitors will result in $N = 3$); β is the phase constant; Z_0 is the characteristic impedance of the implemented transmission line; $f_0 = 298$ MHz is the operating frequency.

Both resonators in Fig. 2 will have identical current distribution corresponding to the blue solid curve in Fig. 1. The curves in Fig. 1 suggest, that the sagittal field distribution for segmented resonator will be more uniform in comparison to conventional resonator. However, the transverse field distribution depends on the implemented transmission line technology and can be estimated by either full wave simulations or measurements.

Results: Photographs of the fabricated transmission line resonators using suspended microstrip technology is shown in Fig.3. In resonator with capacitor-segmented strip (refer to Fig. 3 (a)), series capacitors are formed by overlapping adjacent transmission line sections². The resonator with capacitor-segmented ground plane in Fig. 3 (b) uses lumped components for convenient and identical segmentation of stripe and ground plane. To minimize current discontinuities, each segmentation employs two parallel capacitors having half the required value.

In order to evaluate behavior of the designed coil in the presence of lossy tissue, phantom studies were conducted using a 7T system.

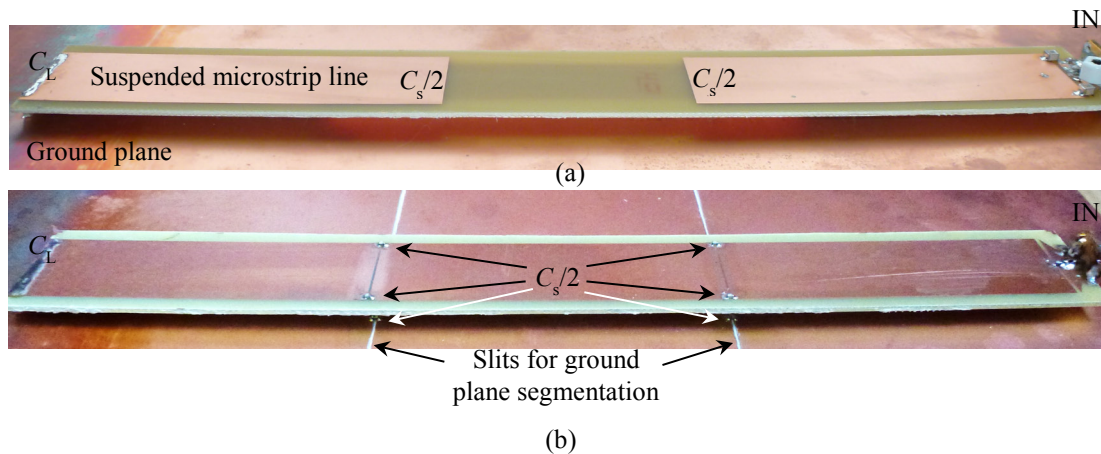

Fig. 3. Photographs of the fabricated microstrip resonators.

(a) – only stripe is segmented, corresponds to case in Fig.2. (a).

(b) – both, stripe and ground plane are segmented, corresponds to case in Fig.2. (b).

The measurement results using a saline phantom are shown in Fig.4.

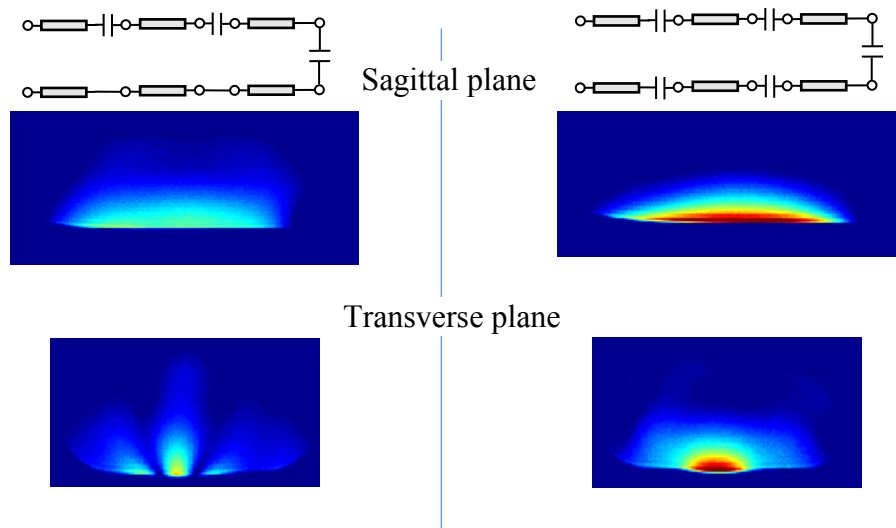

Fig.4. Measurement results. Low flip angle gradient echo images taken with the resonators.

Discussion and Conclusion: As can be seen from comparison in Fig. 4, the design with segmented ground plane provides more uniform field in the transverse plane. On the other hand, sagittal field pattern is not as uniform as for the design with uniform ground plane.

This shows that the magnetic field patterns of the transmission line resonators can be manipulated in sagittal and transverse planes by segmenting both current-carrying conductors with series capacitors. While the field pattern in the sagittal plane depends on current distribution along the resonator, transverse field pattern depends on implemented transmission line technology and can not be estimated using a simple circuit model.

Evenly distributed capacitors were considered in this work (equal value capacitors inserted between equal length line sections). It is expected, that higher homogeneity over a wider field of view could be achieved using unevenly distributed capacitors with variable values.

References:

1. Vaughan J. T. et al. High Frequency Volume Coils for Clinical NMR Imaging and Spectroscopy. *Magn. Reson. in Med.*, 1994, Vol. 32, Issue 2, pp. 206-218.
2. Zhurbenko V. Optimal Value of Series Capacitors for Uniform Field Distribution in Transmission Line MRI Coils. *Journal of Sensors*, vol. 2016, Article ID 3480965. pp.1-7.
3. Panda V. et al. Zeroth-Order Resonator with Stepped Impedance for 7T Magnetic Resonance RF Coil. *Proceedings of 24th ISMRM meeting*, 3563.
4. Zhurbenko V. et al. Large Field-of-View Transmission Line Resonator for High Field MRI. *Proceedings of EuMW2016*, pp.1-4.
5. Yan X., Gore J. C., and Grissom W. A. Tuning Microstrip Coil Field Patterns Using Capacitor-Segmented Ground Planes. *Proceedings of 24th ISMRM meeting*, 3533.

Acknowledgement: The authors would like to thank Danish National Research Foundation (grant D NRF124) and Danish Council for Independent Research (grant 6111-00349A) for partial support of the activities.