

Technical University of Denmark



Practical Aspects of Preamplifier Designs for 13C Imaging.

Johansen, Daniel Højrup; Sánchez-Heredia, Juan D.; Zhurbenko, Vitaliy; Ardenkjær-Larsen, Jan Henrik

Publication date:
2017

Document Version
Publisher's PDF, also known as Version of record

[Link back to DTU Orbit](#)

Citation (APA):
Johansen, D. H., Sánchez-Heredia, J. D., Zhurbenko, V., & Ardenkjær-Larsen, J. H. (2017). Practical Aspects of Preamplifier Designs for 13C Imaging.. Abstract from ISMRM 25th Annual Meeting & Exhibition, Honolulu, United States.

DTU Library

Technical Information Center of Denmark

General rights

Copyright and moral rights for the publications made accessible in the public portal are retained by the authors and/or other copyright owners and it is a condition of accessing publications that users recognise and abide by the legal requirements associated with these rights.

- Users may download and print one copy of any publication from the public portal for the purpose of private study or research.
- You may not further distribute the material or use it for any profit-making activity or commercial gain
- You may freely distribute the URL identifying the publication in the public portal

If you believe that this document breaches copyright please contact us providing details, and we will remove access to the work immediately and investigate your claim.

Practical aspects of preamplifier designs for ^{13}C imaging.

Daniel Højrup Johansen¹, Juan D. Sanchez-Heredia¹, Vitaliy Zhurbenko¹; Jan H. Ardenkjær-Larsen¹,

¹Technical University of Denmark, Department of Electrical Engineering, Ørstedes Plads, 2800 Kgs. Lyngby, Denmark.

Synopsis

This abstract presents two preamplifier designs for ^{13}C imaging optimized either for single or array coil usage. For single coil usage the preamplifier is designed to minimize noise yielding a noise figure of 0.25 dB. For array coils coupling between elements is a problem when the input impedance of the preamplifier is high. Hence the main contribution of this work is a low resistance, inductive input impedance preamplifier yielding better decoupling for array coils, while maintaining acceptable gain (20 dB) and noise figure (0.75 dB).

Purpose

Non-magnetic preamplifiers for 3T ^{13}C MRI is a sparse commodity that is, to the authors knowledge, only available from one vendor, WanTcom¹. This abstract presents two 3T ^{13}C MRI preamplifier designs operating at 32.1 MHz. Design 1 is optimized for the noise figure (NF) and intended for single coil usage. Design 2 optimizes input impedance for array coils using preamplifier decoupling² which is especially useful when utilizing hyperpolarization³. Further, this work elaborates on the practical aspects of preamplifier design describing the vital aspects for matching, stability, NF and gain.

Methods

The important aspect in designing a preamplifier is choosing a proper device for amplifier realization. For practical considerations, in order to simplify the voltage supply, a positive controlled bias transistor is preferable. This leaves two options: either a bipolar or enhancement mode field effect transistor (FET). Bipolar transistors suffer from an inherently higher $1/f$ -noise which impairs the achievable noise for a ^{13}C preamplifier. Among FETs an enhancement mode pseudomorphic high electron mobility transistor (pHEMT) from Avago (ATF54143⁴) has low NF and is chosen in this work.

Another important aspect is to determine an unconditionally stable topology. These considerations have led to the common-source topology shown in Fig. 1. A common-gate topology was investigated as well, but was extremely difficult to stabilize. Source degeneration (adding an inductor between source and ground of the transistor) was attempted but showed instability and was discarded.

In order to optimize the NF a variable series and shunt 1.5-40 pF capacitor was added externally and tuned for optimal noise performance. The optimal impedance preamplifier is designed for a low resistance and inductive input impedance. The schematic for the optimal impedance design is seen in Fig. 1. C3 is a DC block ensuring that the high input impedance of the transistor is shunted by L1. Hence L1 transforms the high input impedance transistor into a low resistance, inductive preamplifier. The layout for the optimal impedance design is found in Fig. 2.

The optimal impedance design and WanTcom WMA32C have been equipped with identical loop coils and measured in a GE Signa HDx 3T clinical scanner⁵. Fig. 3 shows the single coil setup with decoupling network and the optimal impedance preamplifier. The imaging sequence was a CSI with an FOV of 120x120x50 mm³, duration of 19 s and 16x16 points, and the phantom was a 1 M ^{13}C -bicarbonate phantom.

Results

The measured NF, gain and input impedance is found in Table 1 for both designs and the WMA32C. Measured SNR is seen in Fig. 4. Notice that in design 2 the gain drops by 8 dB and NF rises 0.05 dB compared to the WMA32C. However, measured SNR remains unimpaired. In terms of performance of the optimized impedance design in an array please refer to another ISMRM abstract by J. D. Sanchez-Heredia et al.

Discussion

The results indicate that preamplifier noise is not the dominant noise contribution for a loop coil of 5 cm diameter. This makes it possible to optimize the preamplifiers impedance yielding better array decoupling while not impairing the single coil's SNR by trading-off gain and NF. Indeed the exact trade-off between NF, gain, impedance and SNR is unclear but this abstract indicates that the trade-off made here is acceptable.

In terms of the preamplifier designs it may be possible to select another transistor having better low frequency stability. Due to the transistor gain increasing significantly at lower frequencies extra dampening of gain is required. Perhaps another transistor with a worse NF rating may be better at 32 MHz if the extra stability measures were not needed. Also, the output is not matched to 50 ohms though the dampening circuit formed by R4, R5 and the load does yield a match of 2.2:1 VSWR. Hence better performance can be achieved.

Finally, the size of L1 can cause unwanted coupling between the preamplifiers in an array. Hence shielding of the preamplifier is needed.

Conclusion

Two preamplifier designs have been proposed for 3T ¹³C imaging optimizing either noise figure or the input impedance. The first design showed a noise figure of 0.25 dB making it, to the knowledge of the authors, best in class. However, when considering hyperpolarized ¹³C imaging an array is usually preferred. Thus the second design optimized the input impedance to 0.4+j67 Ohms with a NF of 0.75 dB and gain of 20 dB. In another abstract, this has proven to yield a significantly better decoupling and thus higher SNR of an array when compared with the WMA32C preamplifier.

References

1. WanTcom Inc. *WMA32C Datasheet*. (2013).
2. Roemer, P. B., Edelstein, W. A. & Hayes, C. E. The NMR Phased Array. **225**, 192–225 (1990).
3. Lee, R. F. *et al.* Advantages of parallel imaging in conjunction with hyperpolarized helium - A new approach to MRI of the lung. *Magn. Reson. Med.* **55**, 1132–1141 (2006).
4. Avago. *ATF-54143 Datasheet*. (2012).
5. Sánchez-Heredia, J. D., Hansen, E. S. S., Laustsen, C., Zhurbenko, V. & Ardenkjaer-Larsen, J. H. Decoupling Scheme for a Cryogenic Rx-Only RF Coil for ¹³C Imaging at 3T. *Proc. Intl. Soc. Mag. Reson. Med.* 3639 (2016).

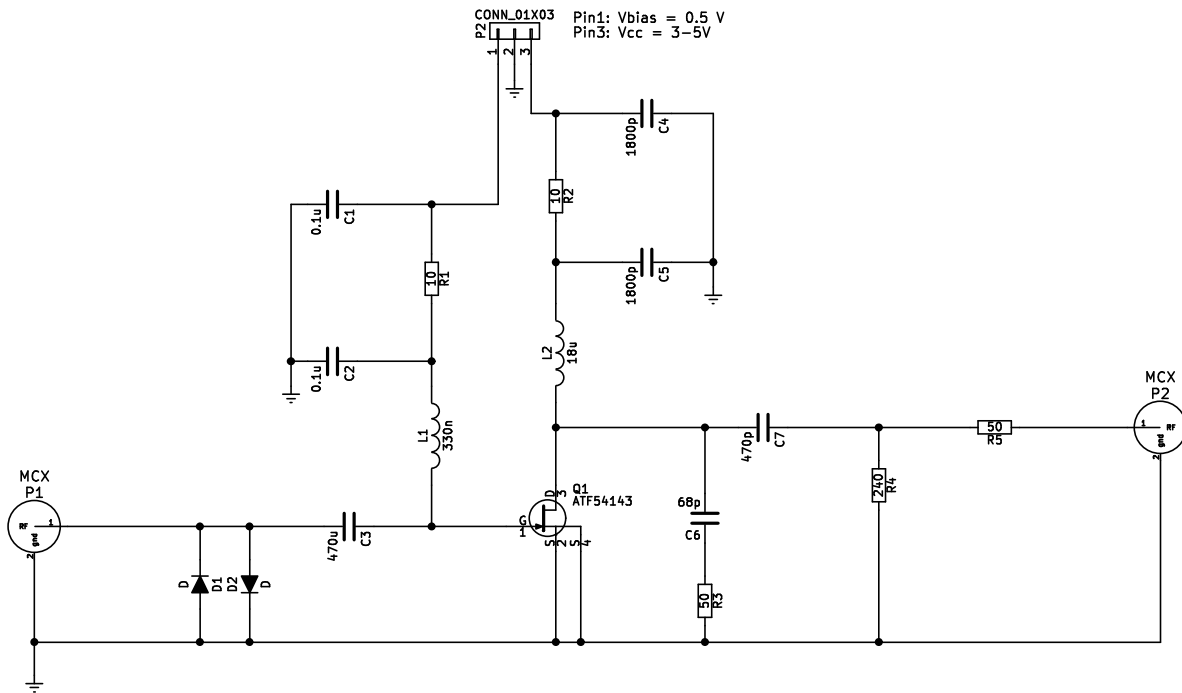

Figure 1: Schematic of the preamplifier. To ensure stability the biasing network consisting of L1, C2, R1 and C1 is paramount. L1 and C2 forms a low frequency short circuit to ground on the input. C1 and R1 forms a filter ensuring that no amplification path is present in the supply path. On the output R3 and C6 forms a low pass filter ensuring high frequency stability. The network formed by R4, R5 and the load (assumed 50 ohms) is a dampening circuit that decreases the gain to further ensure stability.

Preamplifier	Noise figure [dB]	Gain [dB]	Impedance [Ohm]	SNR
WMA32C	0.7	28	3	425
Optimal NF	0.25	23	1-j24	—
Optimal impedance	0.75	20	0.4+j67	424

Table 1: Measured noise Figure, gain and input impedance of the two designs and the WMA32C.

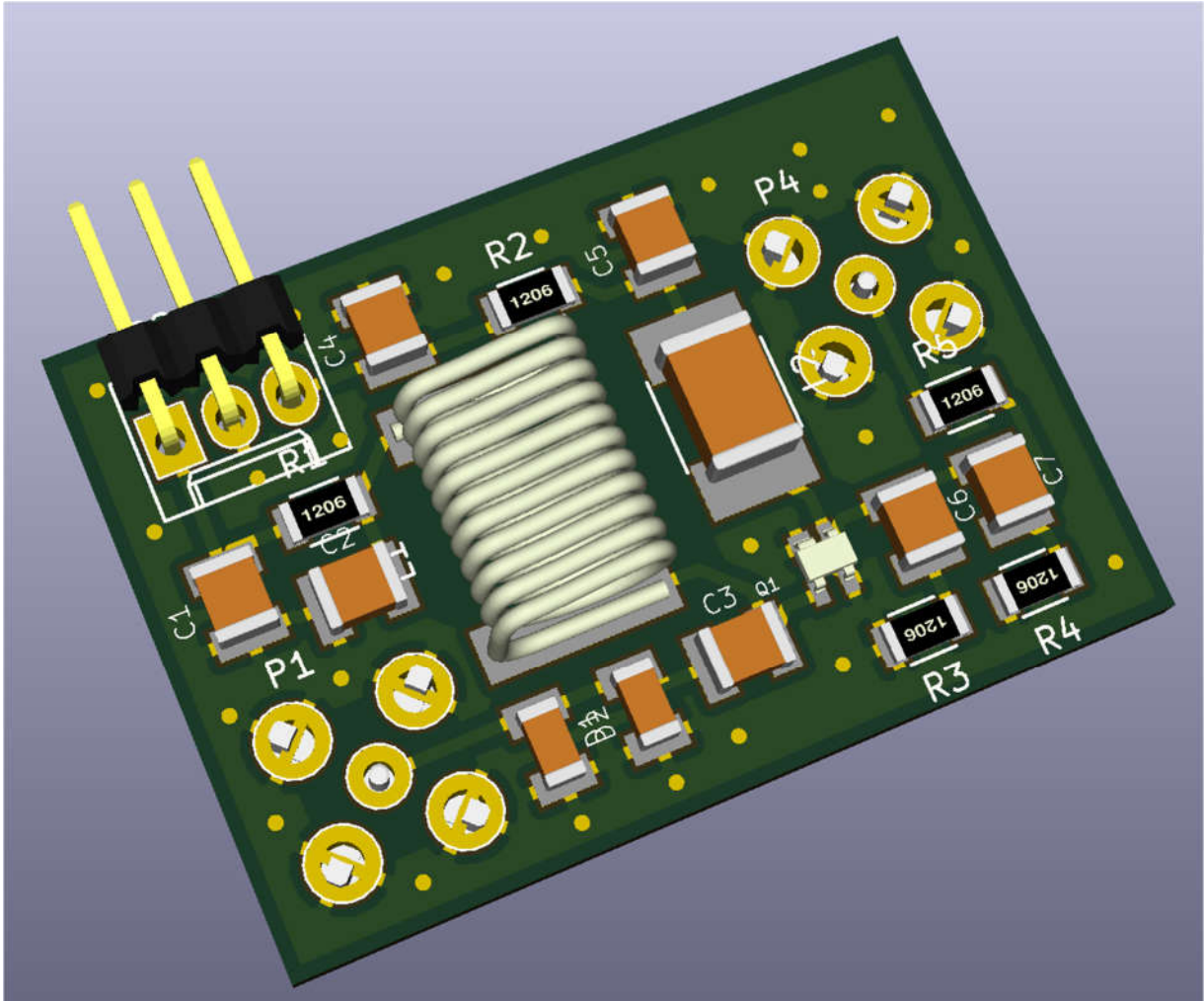

Figure 2: Layout. It is very important during layout to minimize the inductance from source to ground or the preamplifier will become unstable.

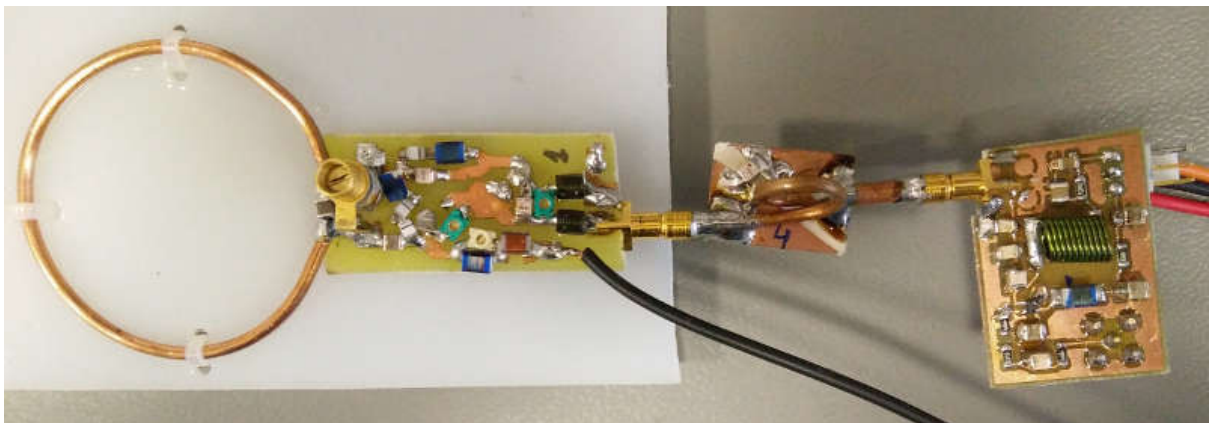

Figure 3: From the left is seen the coil, with a diameter of 5 cm. Next is the decoupling network and finally the optimal impedance preamplifier without copper shield.

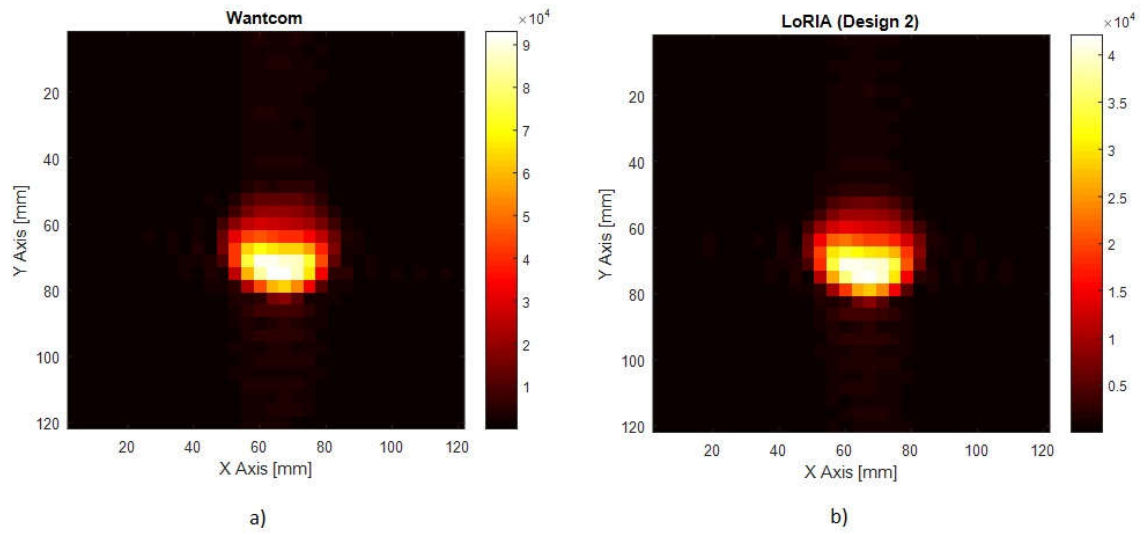

Figure 4: Measured image of a) the WanTcom (SNR=425) and b) the optimized impedance design (SNR=424).