

Photovoltaics merging with the active integrated grid

Grid integration white paper of the EU PV technology platform, working group on grid integration.

Alet, Pierre-Jean; Baccaro, Federica; De Felice, Matteo; Efthymiou, Venizelos; Mayr, Christoph; Graditi, Giorgio; Juel, Mari; Moser, David; Petitta, Marcello; Tselepis, Stathis; Yang, Guangya

Publication date:
2017

Document Version
Publisher's PDF, also known as Version of record

[Link back to DTU Orbit](#)

Citation (APA):

Alet, P-J., Baccaro, F., De Felice, M., Efthymiou, V., Mayr, C., Graditi, G., ... Yang, G. (2017). Photovoltaics merging with the active integrated grid: Grid integration white paper of the EU PV technology platform, working group on grid integration. European Technology and Innovation Platform Photovoltaics.

DTU Library

Technical Information Center of Denmark

General rights

Copyright and moral rights for the publications made accessible in the public portal are retained by the authors and/or other copyright owners and it is a condition of accessing publications that users recognise and abide by the legal requirements associated with these rights.

- Users may download and print one copy of any publication from the public portal for the purpose of private study or research.
- You may not further distribute the material or use it for any profit-making activity or commercial gain
- You may freely distribute the URL identifying the publication in the public portal

If you believe that this document breaches copyright please contact us providing details, and we will remove access to the work immediately and investigate your claim.



PHOTOVOLTAICS MERGING WITH THE ACTIVE INTEGRATED GRID

**A WHITE PAPER BY THE EUROPEAN PV TECHNOLOGY PLATFORM,
WORKING GROUP ON GRID INTEGRATION**

TABLE OF CONTENTS

Introduction	5
Quantifying PV penetration: metrics and current levels	6
Qualitative levels	6
Fraction of electric energy demand	7
Fraction of generation capacity	8
Installed capacity as a fraction of load	8
Penetration level of distributed energy resources	9
Hosting capacity	10
Recommendations	10
Barriers to wider deployment of PV into power grids	11
Local technical barriers	11
<i>Voltage issues</i>	<i>11</i>
<i>Harmonics</i>	<i>12</i>
<i>Reverse power flows and transformer loading</i>	<i>13</i>
System-wide technical barriers	14
<i>Reduction of system resilience</i>	<i>14</i>
<i>Intermittency</i>	<i>15</i>
Integration costs	16
Solutions for increasing the PV hosting capacity of power grids	17
Control of active power	17
Control of reactive power	17
System-support functions of inverters	18
Forecasting	19
<i>PV system modelling</i>	<i>19</i>
<i>Weather forecasting</i>	<i>19</i>
<i>Accuracy and impact on storage</i>	<i>20</i>
Combination with other renewable sources	20
Energy storage	21
<i>Overview of storage technologies</i>	<i>22</i>
<i>Combined PV + storage generating units</i>	<i>23</i>
Micro-grids	25
Enabling factors	25
<i>Regulation</i>	<i>25</i>
<i>Net metering</i>	<i>26</i>
<i>Communication standards</i>	<i>27</i>
<i>Planning rules</i>	<i>28</i>
PV as building block of future power systems	29
Reduced investments in existing grids	29
Electrification through hybrid systems	29
Conclusion	31
References	32
Acronyms	35

Authors

Lead author:

Pierre-Jean Alet

Contributors (in alphabetical order)

Federica Baccaro, Matteo De Felice, Venizelos Efthymiou, Christoph Mayr, Giorgio Graditi, Mari Juel, David Moser, Marcello Petitta, Stathis Tselepis, Guangya Yang

Layout and Printing

Secretariat of the
European Photovoltaic Technology Platform
Tel: +49-89-720 12 722
Fax: +49-89-720 12 791
secretariat@eupvplatform.org

Disclaimer

The opinions expressed in this document are the sole responsibility of the European Photovoltaic Technology Platform and do not necessarily represent the official position of the European Commission.



"This project has received funding from the European Union's Seventh Programme for research, technological development and demonstration under grant agreement No 609783"



Introduction

How much is too much? Asking this question with respects to photovoltaics would have seemed absurd just a few years ago. Yet from Japan [1] to Europe to the Americas, loud voices are claiming that Photovoltaics (PV) is reaching excessive levels on the grids or, at least, growing at excessive rates. Economic as well as technical issues are put forward.

Indeed, PV power generation has moved in just a decade from a curiosity to a significant part of power systems around the world. Global investment in new PV generation capacity was US\$ 173.6 billion in 2013, nearly two thirds of the gross investment in fossil-fuel power generation (US\$ 270 billion) [2]. Solar PV is estimated to have provided 0.7% of the global electricity demand in 2013 [3]. The central point in Levelised Cost of Electricity (LCOE) at the beginning of 2014 was about US\$ 150 per MWh; there is now a significant overlap between the LCOE ranges of PV electricity and conventional power generation (natural gas combined-cycle turbines, coal, nuclear) [2], which means that solar PV can be cost-competitive at the point of generation in some regions.

As PV is essentially a distributed energy resource, it clashes with the centralised architecture of existing grids. Together with other renewable energy sources, it challenges the business models of incumbents in the power sector, be they network operators or power generators. Some of these incumbents may be tempted to exaggerate the negative impact of PV, and minimise its benefits. Others have already taken radical steps to adapt to this new situation [4].

The benefits of PV generation in terms of environmental impact and energy security are well documented [5]. This is why the European PV Technology Platform aims at enabling the massive deployment of photovoltaics into the power system. It acknowledges the technical challenges that come with it. We believe that these challenges are best addressed through rational assessment of the situation and co-operation between the power and PV industries.

With this paper we set to clarify the terms of this discussion: how is penetration of PV into power grids evaluated? What are the current levels? Which barriers may prevent increasing these levels? Which concepts have been put forward to open these barriers? Which benefits can PV systems provide for existing and new grids? Immediate recommendations are formulated in this paper; we also expect that further collaboration with the power sector will lead to more robust knowledge and to a power system with PV at its heart.

Quantifying PV penetration: metrics and current levels

Qualitative levels

A simplified definition of different PV penetration levels was established in [6] based on the directionality of the net power flows at the point of interconnection between Distribution System Operator (DSO) and Transmission System Operator (TSO). The electricity supply system of every country that is aiming at increasing its share of PV on the total electricity mix will typically face three different development stages:

1. Low/ medium PV penetration in a few distribution grids: local consumption exceeds local generation (uni-directional distribution grids)
2. High PV penetration in few distribution grids: local generation can exceed local consumption (bi-directional distribution grids)
3. High PV penetration in many distribution grids: PV is a major electricity source



Fraction of electric energy demand

The net fraction of electric energy demand met by PV generation can be defined at any scale, from a single building to the entire world. The integration period is generally one year. This metric is widely used in discussions of energy policy, although in that case PV is often combined with other “new” renewables such as wind.

Current values are (net basis, over one year):

- ▶ At EU level: about 3% [7]
- ▶ At national level: from about 0.5% (The Netherlands) to 7.5% (Italy) [7]
- ▶ At single-house level with rooftop PV system: about 100%

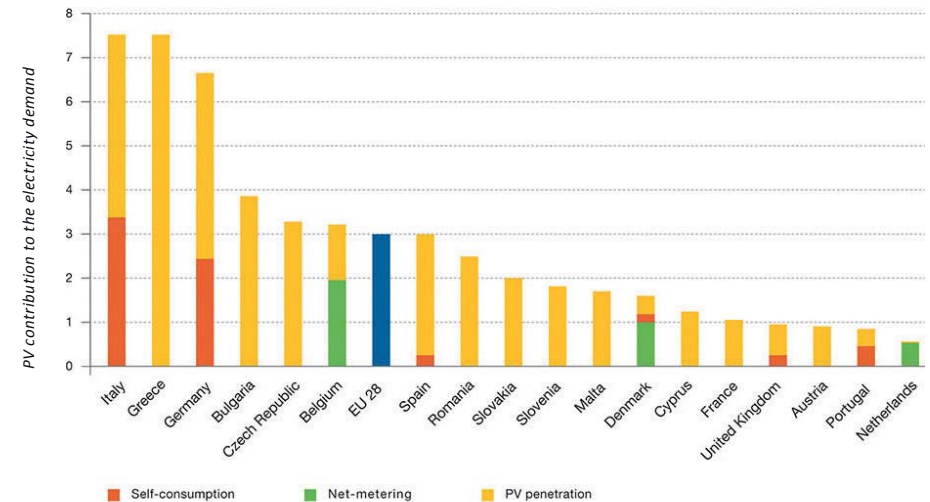

Figure 1: Relative contribution of PV to the electricity demand of EU28 countries [7]

Depending on climate, energy mix, or patterns of electricity usage grid-related challenges in achieving similar fractions of electricity demand covered by PV may greatly vary.

Fraction of generation capacity

The fraction of generation capacity i.e., ratio between nominal PV (AC) power capacity and total installed generation capacity, is mostly used in market-related studies at national or continental scale. Indeed, it is a good indicator of the development of the PV market in terms of investments. It also characterises the challenges facing balancing authorities e.g., to guarantee that flexible capacity is available to compensate fluctuations in generation [8].

At the end of 2012, values of penetration as fraction of generation capacity were:

- ▶ At EU level: 7.2% [9]
- ▶ At national level: 13.2% (Italy), 18.4% (Germany) [9]

However, to better reflect the situation of the power system, we would recommend using an availability-weighted share of generation capacity.

Installed capacity as a fraction of load

PV installed capacity (or maximum production) can be expressed as a fraction of minimum or maximum load [7]. This fraction can meaningfully be calculated at any level of the electricity network. At low and medium voltage levels, it characterises the need for grid reinforcement. At transmission system level, it qualitatively characterises the challenges in meeting base load demand while managing variability.

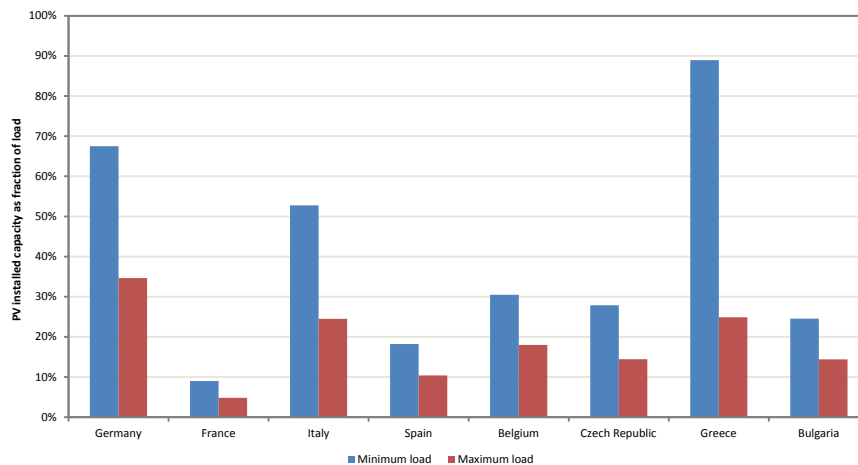

Figure 2: Installed PV capacity as of 2013 in eight European countries as a fraction of minimum and maximum load levels (mid-day peak between May and September) adapted from data in [7].

Levels as of 2013 are shown on Figure 2. In Greece, Italy and Germany the installed PV capacity exceed 50% of the minimum load between May and September (when PV generation is generally higher). However, thanks to the dispersion of PV systems in location and design, different PV systems produce at full capacity at different times. The ratio between the actual peak PV production and the load (instantaneous penetration level) is therefore lower than the figures shown on Figure 2. Instantaneous penetration levels have reached 77% and 46% in Germany. Several other countries have recorded maximum instantaneous penetration levels between 20% and 25%.

Penetration level of distributed energy resources

When considering distribution networks, especially at the low-voltage level, a penetration level can be defined as the ratio between the total AC peak power of installed PV systems and a reference power value. Three different references have been used with success in grid integration studies:

1. **Rating (in kVA) of the transformer** [10]: penetration level defined in this way is attractive in that it relates to a physical characteristic of the network which is relevant to grid integration issues of PV. Provided distribution networks follow comparable engineering rules (e.g., regarding the types of cables to be used), similar figures for such-defined penetration levels should yield similar results in terms of integration capability.
2. **Rating of the transformers feeding the area, after correcting the installed PV power with the nominal load:**

$$K_f \triangleq \frac{P_{DG,nom} - P_{load,min}}{P_n} \quad \text{this definition is inspired by Italian regulations (TICA) [11].}$$

These regulations define four categories of areas in medium and low voltage with respect to the integration of distributed generation, which are to be regularly reported on maps of the distribution networks:

- a. White: $P_{DG,nom} \leq \frac{P_{load,min}}{2}$
- b. Yellow: $\frac{P_{load,min}}{2} < P_{DG,nom} \leq P_{load,min}$
- c. Orange: $0 < P_{DG,nom} - P_{load,min} \leq 0.9 \cdot P_n$
- d. Red: $0.9 \cdot P_n < P_{DG,nom} - P_{load,min}$

Where $P_{load,min}$ is the minimal power load in the area, measured on a 15-min basis; P_n is the total nominal power of the HV/MV transformers feeding the area, and $P_{DG,nom}$ is the total nominal power of requested or active distributed generators connected in the area. An area could then be characterised as precarious if $K_f > 0$ and critical if $K_f > 0.9$

3. **Total capacity (on a feeder) that would be reached if all customers installed a system of optimal economic size from their point of view** [12]: calculating the penetration level with this definition requires much work, unless the customer profiles are very homogeneous. Its attraction is in the fact that a penetration level of 100% is the likely maximum value for all feeders.

Hosting capacity

Hosting capacity characterises an electrical network rather than the PV generators installed on it. It is an absolute metric, defined as the maximum total peak power of PV systems that can be connected to the network under consideration while meeting key performance indices covering voltage, protection, power quality, and component loading [13]. Different values may be obtained for different indices, and the unqualified hosting capacity should refer to the minimum value obtained for all indices. This metric, while very important, suffers from several practical limitations:

- ▶ It is highly dependent on the specifics of the network under consideration.
- ▶ For a given network, it may vary depending on the choice of performance indices. There is no standard set of performance indices. Electric Power Research Institute (EPRI) for example uses 15 indices [14].
- ▶ Its accurate estimation is computationally intensive as it requires time series or stochastic analyses, the underlying principle being gradually to increase penetration levels until some violation occurs.

When a single figure is mentioned for hosting capacity, it has normally been calculated under worst-case assumptions. EPRI, which uses stochastic analysis, defines three bands of PV peak power values:

- ▶ Between 0 and minimum hosting capacity: no observable violations regardless of size and location of PV systems.
- ▶ Between minimum and maximum hosting capacity: possible violations depending on size or location.
- ▶ Above maximum hosting capacity: observable violations occur regardless of size and location of PV systems.

Recommendations

A large number of different metrics is being used to characterise the penetration level of PV generation into power systems. While we tried to clarify their definition and scope, we believe that work is needed to make quantification more robust and facilitate comparison between studies:

- ▶ The quantitative relationship between the different metrics should be investigated.
- ▶ A limited set of metrics should be selected as references, for example the fraction of energy demand and the hosting capacity.
- ▶ A standard set of key performance indicators for the hosting capacity should be determined.

Barriers to wider deployment of PV into power grids

Local technical barriers

Voltage issues

Whereas distribution grids are conventionally designed for decrease in voltage along feeders, injection of active power by PV systems can lead to an increase in voltage along feeders. Figure 3 illustrates this shift. The quantification depends on the consumption profile in the feeder in particular, time alignment with PV power generation.

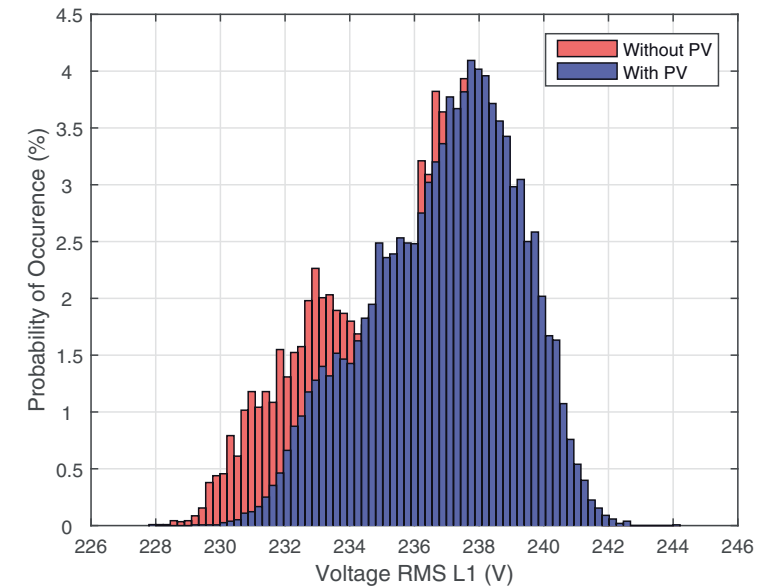

Figure 3: distribution of voltage in a low-voltage feeder before and after installation of PV [15]

Within highly PV penetrated distribution grids the installed PV capacity frequently exceeds the local peak load, which can lead to significant over-voltage and over-loading issues. Physical grid reinforcement (installation of additional or larger cables) is generally necessary to eliminate this effect. However, this reinforcement and the increased (reverse) power flows change the reactive power behaviour of the distribution system. Indeed, reactive power consumption by conductors increases both during

times of high solar irradiation increases, due to increased active power flows and at night due to augmentation (e.g., additional cables).

In many grid configurations, overvoltage is the first issue to occur. In typical residential underground, residential UK feeders, 30% of connected customers operating a PV system up to 4 kW are the maximum before voltage deviations outside the acceptable range (as per EN 50160 standard [16]) start occurring [17].

Harmonics

Harmonics can have detrimental effects such as increased device heating, malfunction of electronic equipment and protection, incorrect readings on meters, or triggering of resonant conditions.

As measurements in Figure 4 show, the probability of higher levels of Total Harmonic Distortion (THD) on distribution networks increases with the introduction of PV. Current harmonics are injected by PV inverters due to switching (pulsed-width modulation); they are influenced by the topology [18] and the controller [19] of the inverters. Cost pressure has limited progress in this area.

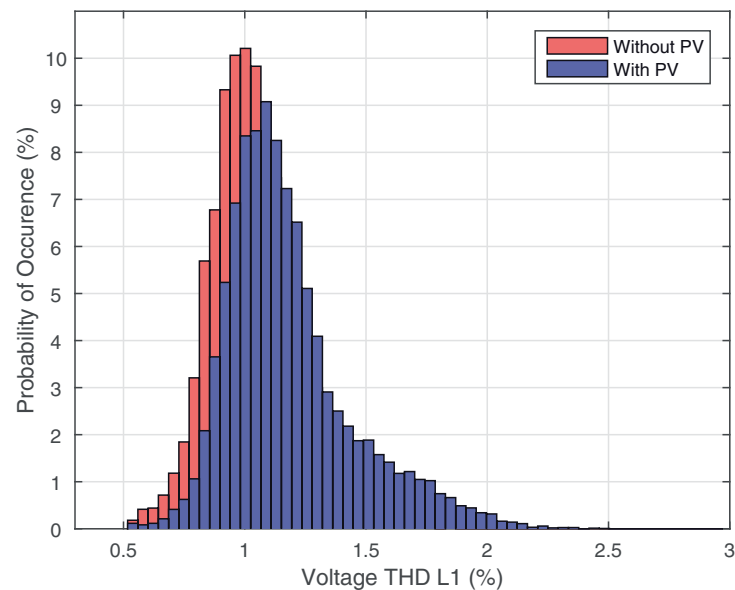

Figure 4: Probability distribution function of Total Harmonic Distortion (THD) on a distribution network without (red) and with (blue) PV [15].

Reverse power flows and transformer loading

The loading of transformer can be affected by the PV penetration level as well as the voltage control methods, in case inverter supplies reactive power compensation for supporting grid voltages. Figure 5 illustrates a general trend of yearly transformer overloading with respect to the increasing PV penetration level at the presence of inverter reactive power control. The increasing of transformer overloading shows nonlinear characteristics with respect to the PV penetration. At low penetration levels, the transformer loading situation will not be affected by the PV, which assigns with the design principles of the current grids. With increasing penetration levels, there could be a sharp increase of the transformer overloading due to the amount of active power generation as well as increased reactive power generation from inverters.

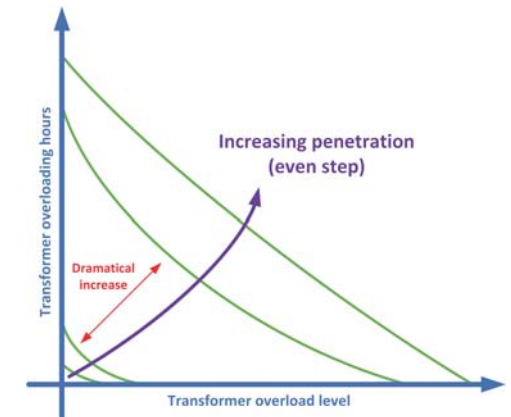

Figure 5: Yearly transformer overload situation with respect to the increasing PV penetration based on data from the PVNET.dk project [12]

This problem can also be reflected from grid loss analysis. Studies in [12], [20] show that the grid losses can be reduced in general at low penetration levels until a critical penetration level is reached. Afterwards the grid losses will increase more rapidly regardless of the control methods used, as shown in Figure 6.

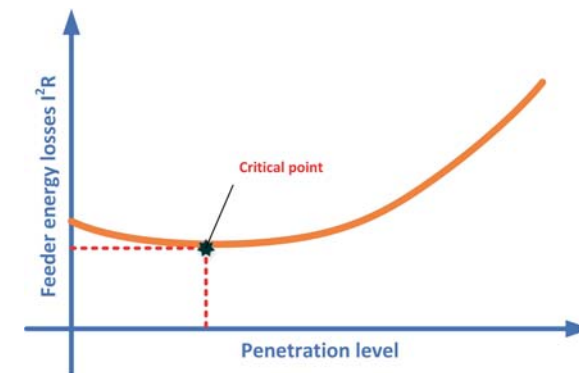

Figure 6: Evolution of grid losses with increasing PV penetration levels [12]

System-wide technical barriers

Reduction of system resilience

Deployment of PV systems can reduce the resilience of power systems in four ways:

- ▶ Generators connected through power inverters such as PV have lower inertia than conventional, rotating generators. This lower inertia reduces the available time for the system to respond to the sudden loss of large power plants.
- ▶ PV systems can displace generators which are used for primary frequency control reserves.
- ▶ Secondary control reserves are increasingly used due to power ramps [21].
- ▶ At high penetration levels of distributed PV systems, reverse power flows from the distribution level to the transmission system can frequently occur. These flows lead to an increased demand in re-dispatch of conventional power plants and revised procedures for congestion management.

In addition, PV inverters follow frequency and may disconnect en masse when grid frequency falls outside nominal range. Regulation originally assumed PV was marginal in the power system but now Europe-wide collapse in case of loss of 30 GW to 50 GW of PV generation is possible [22].

Phase III of the Grid Integration of Variable Renewables project (GIVARIII) [23] evaluated the capacity of power systems to deal with rapid swings in supply and balance over time scales from one hour to 24 hours. This assessment was carried out using the IEA revised Flexibility Assessment Tool (FAST2). Technically-feasible shares of variable renewables (i.e., solar and wind) given currently installed flexible resources were evaluated by calculating how often insufficient system flexibility occurred over given years and penetration levels. The analysis showed that if flexibility is a priority for system operation, variable renewables can supply from 25% to 40% of annual electricity demand without any shortfall in flexibility.

Intermittency

All photovoltaic systems depend on the ambient solar irradiance for their energy generation. This irradiance is highly variable in time and in space. The resulting variability of PV power output is considered a physical limitation of the technology. Figure 7 illustrates this issue by showing how the power generation of a single PV system can vary over a few days. As shown on Figure 8 however, the rapid fluctuations are naturally mitigated when even a low number of generators and consumers are considered. This phenomenon is well known for loads, where it is characterised by the coincidence factor and can be used to optimise investments in power networks. The smoothing effect of aggregation further increases at larger spatial scales [24].

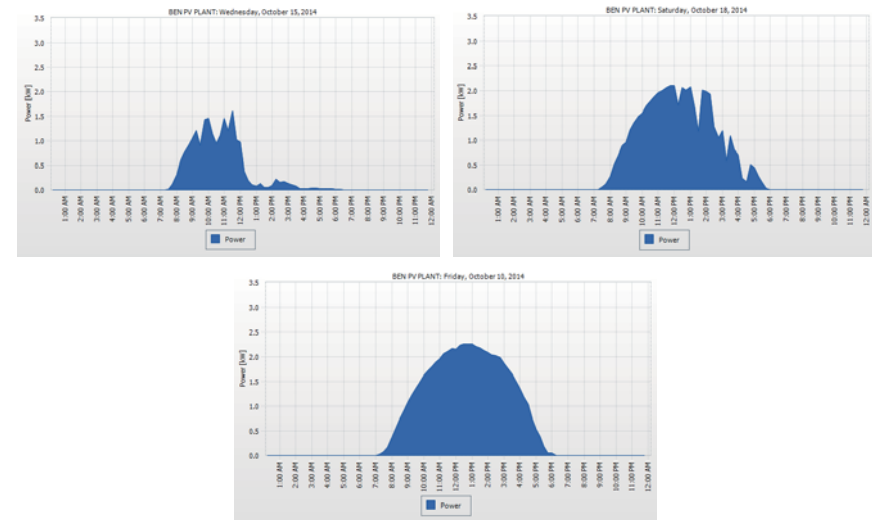

Figure 7: Power output of a single PV power plant in three days of October 2014 [based on records of an SMA inverter from a single system on the roof of a domestic consumer in Cyprus]

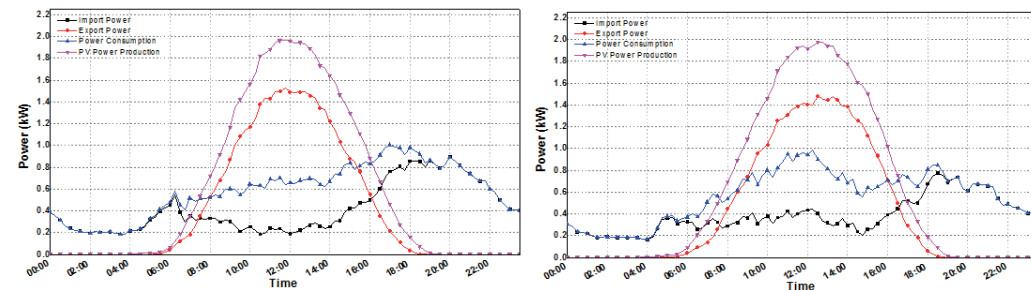

Figure 8: Aggregated power for seven prosumers showing generation, consumption, import and export over week days (top) and weekends (bottom) [25]

Integration costs

Integration costs and appropriate ways to calculate are already well documented for wind power [26]–[29]. These costs could be defined as an increase in power system operating costs or as extra investment to the existing non Variable Renewable Energy (VRE) infrastructure. PV has the unique ability to produce electricity close to where it is consumed alleviating the need for investment in new transmission lines. The PV Parity project recently assessed grid costs associated with integrating solar PV into the EU grid (up to 15% generation in Europe by 2030) and found modest transmission costs [30]. In 2020 the cost is estimated at ca. 0.5 €/MWh for a PV penetration level of 240 GW, increasing to 2.8 €/MWh by 2030 at a PV penetration level of 485 GW. Reinforcing distribution networks to accommodate 485 GW of solar PV capacity, providing 15% of European electricity demand, would cost about 9 €/MWh by 2030.



© Gina Sanders

Solutions for increasing the PV hosting capacity of power grids

Control of active power

The idea of controlling the active power output of PV systems to provide technical services to the DSO is gaining in importance. Typically, active power control – without storage it is actually limited to active power reduction – is a common tool for DSOs to overcome short-term network congestions by reducing the power output of utility-scale PV systems.

The simplest form of active power control at the PV systems point of common coupling is to solely use the PV inverter for active power reduction. State-of-the-art solutions are static caps in feed-in power (e.g., the 70% cap as required by the German EEG from 2012) or DSOs sending active power feed-in limitation set values via a remote control interface.

As compared to these approaches, volt/watt control of active power would be attractive by reducing active power only when local grid conditions require it (in case of over-voltages) and hence reducing the overall active power losses over all PV system within a certain grid section [31], [32]. However this control will discriminate PV systems with technically unfavorable points of common coupling. In such a case, approaches for the compensation of lost energy need to be developed.

In addition, to support frequency control, droop curves can be implemented to automatically reduce active power with in case of frequency deviations (over-frequency response).

Control of reactive power

Reactive power supply/absorption for voltage support can significantly reduce grid extension costs. Initially, reactive power provision via PV inverters was established to mitigate high voltage magnitudes caused by reverse power flows. Numerous studies highlighted the technical potential of reactive power for increasing the hosting capacity of a grid, although the technical effectiveness decreases with lower voltage levels [7], [31], [33]–[37].

Reactive power provision can be classified in static reactive power provision and dynamic reactive power provision.

Static reactive power provision: In many IEA Task 14 member countries, static reactive power provision capability is required by PV systems, however its practical utilization is up to the local DSO, e.g. [38], [39]. Typical applications for residential scale PV systems focus on autonomous ways (i.e., without additional information and communication interface to the DSO) of providing reactive power to mitigate voltage rise, such as the provision of a fixed power factor. Utility scale PV systems typically come with a remote control interface that allows DSO to transmit reactive power set values to the PV plant.

Voltage dependent reactive power provision (so-called volt/var control) is considered more advanced as it provides reactive power based on the locally measured voltage magnitude of the inverter. Various research projects are currently investigating the technical performance of such a control strategy with a focus on local stability issues [40], [41].

Dynamic reactive power provision: PV systems and other generating units connected mostly to the medium- and high-voltage levels are required in some countries to inject reactive current in order to stabilize the grid in cases of voltage collapses [38], [42]. This technical service is known as fault-ride through. Depending on the magnitude and duration of the voltage dip, the inverter is required to stay connected, inject reactive current or disconnect based on a characteristic that is part of each country's technical specification. The study in [20] coordinates the PV control parameters to improve the grid performance hereby improve the grid hosting capability.

System-support functions of inverters

Inverters have additional capabilities to support grid operations:

- ▶ Controlling power factor (PF control mode)
- ▶ Low-voltage ride-through: Figure 9 shows system response after a fault during which the DG stays in through the active control of advanced inverters that are capable of sustaining fault ride through in line with the EN 50438 and VDE-AR-N 4105 standards.
- ▶ Supplying reactive current during fault period.
- ▶ Controlling PV generation to a specified percentage of nominal power rating (remote dispatch).
- ▶ Automatically reducing active power with over-frequency.

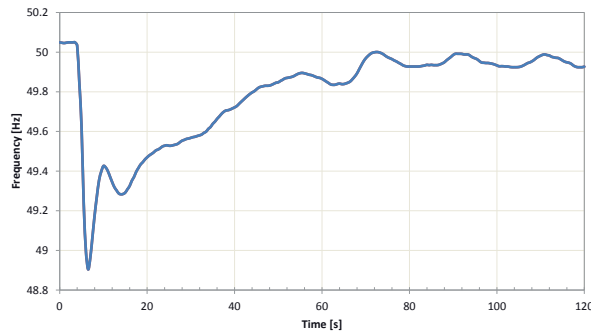

Figure 9: System response after a fault with support from distributed generators [real records from a system in Cyprus]

The effectiveness of the capabilities mandated by the standards EN 50438 and VDE-AR-N 4105 has been experimentally confirmed. Voltage can be controlled within the requirements of grid rules (Figure 10 and Figure 11) with local generation equivalent to load, quality of supply can be controlled with harmonic content below the limits set by grid codes, and frequency control can be fully supported through the control of active power output.

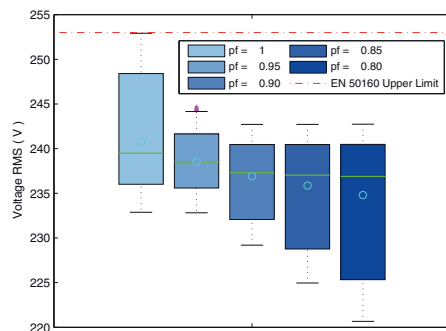

Figure 10: Response of adopted voltage regulation methods [43]

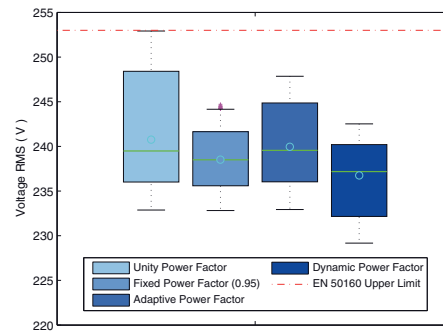

Figure 11: Fixed Power Factor Scheme set to different values [43]

Forecasting

An effective modelling and forecasting of power output of PV systems relies on two aspects: modelling the performance of PV systems as a function on operating conditions, and predicting the weather parameters which affect the output of PV systems i.e., temperature and irradiance.

PV system modelling

Production of a PV system can be modelled in two ways: with a physical model or with a data-driven, “black-box” model. A physical model consists in a set of equations describing the physical behaviour of the photovoltaic module. The data-driven approach “only” tries to reproduce the relationship between observed inputs (e.g., meteorological conditions) and outputs (e.g., power output). The former approach can be more accurate but in addition to meteorological variables (incoming solar radiation, air temperature, wind speed, etc.) it needs solar panel characteristics (technology, area, orientation, etc.) and their evolution during time (e.g., due to degradation). Conversely, the black-box approach does not require information about the type of PV panel but it needs long time-series of input and output variables to calibrate a reliable model. A trade-off can result in intermediate approaches (“grey-box” modelling).

Weather forecasting

The behaviour of a PV system is mainly influenced by weather conditions: incoming solar radiation, ambient temperature and wind speed on PV modules. The techniques to forecast these meteorological variables can be divided in three main groups.

Numerical Weather Prediction models

The Numerical Weather Prediction (NWP) models are essentially based on the numerical integration of coupled differential equations that describe the dynamic of the atmosphere and radiation transport mechanisms. The main advantage of these forecasting methods is that they are based on deterministic physical models. On the other hand, the main problem, in addition to the non-linearity of the used equations, is the spatial resolution of the integration grid that is normally too coarse with respect to the PV plants size. Inside the grid cell the cloud cover and aerosol are homogeneously fixed at their average values thus great errors could be induced both in the amount and in the time of the forecasted irradiance on the PV site. Perez et al. [44] presented an extensive validation of short and medium term solar radiation forecast for various sites in the US.

Statistical models

The statistical models are based on methods to reconstruct the relations between the variables and past meteorological parameters (e.g. cloud ratio, air temperature, relative humidity, pressure etc.) or past observations. The most used models are based on machine learning methods (e.g. neural networks, support vector machines) or time-series based methods (e.g. ARIMA/X, SARIMA/X models). With this method the forecast could be achieved by fast simple algorithms that use only local meteorological measurements and statistical feature parameters. Furthermore, in this way spatial and temporal resolution problems are overcome. On the other hand these methods are not able to provide a good forecast in unstable weather conditions.

Hybrid models

The hybrid models combine both NWP and statistical models. The first one is used for the forecast while the second to correct the site effects through local measurements. The statistical models are essentially used to downscale the weather forecast.

Obviously, for an effective and robust modelling approach, the uncertainty of meteorological data must be limited. To this end, it is important to assess the reliability of the meteorological datasets and forecast available on the specific geographical domain. Data sources can be satellite data, observations provided by ground stations, data produced by NWP models and reanalyses.

The approach to forecast PV production is dependent also on considered the time scale. Forecast at hourly and daily timescales has been demonstrated to be effective considering both white and black-box approaches. Forecast approaches with longer timescales (monthly to annual) can be based on seasonal climate forecasts. At decennial timescales, climate scenarios start to play a relevant role and an analysis of expected climate must be integrated.

Accuracy and impact on storage

Despite efforts to improve forecast techniques, they still incur high error rates. A way to overcome this issue is to combine forecast with the use of local storage in order to rectify deviations between forecast and produced electricity (time mitigation) or to combine a large amount of PV generators distant from each other so individual errors are independent and the overall forecast error is reduced (spatial mitigation). The accuracy of forecasting has an impact on the sizing of the local storage needed to address rapid variability. The combination of fore-

casting, storage and distant PV installations leads to smoother curves, small values of variability in short timeframes and more accurate prediction of PV power generation.

Combination with other renewable sources

Since the dependence of other renewable sources such as wind on time and location is different from that of PV, combining them helps mitigating the impact of variability. A remarkable example is the Greek island of Crete [45]. With an annual peak load of 640 MW, Crete is served by an isolated electric system with an average annual renewable electricity share of 23% (2013) and a maximum renewable capacity share of 44% (consisting of 186 MW wind power and 95 MW of PV power) compared to peak demand in 2012.

At present, during normal operation, PV plants provide power output without any restrictions, while wind parks contribute under constraint of the maximum allowable instantaneous renewable share, which is about 40%. If this value is reached, the power output of the wind parks is appropriately reduced. The energy control center of Crete continuously monitors the wind parks and a set-point for maximum power output is given up to every 5 minutes, if needed. However, in some periods, the operators may decide to operate the system with higher instantaneous capacity share (up to 60%, see Figure 12). The energy control center also monitors selected PV plants at various locations in order to assess the total PV production with a good accuracy. This helps the daily scheduling of conventional capacity. Distributed PV plants also support the grid voltage stability during daily hours.

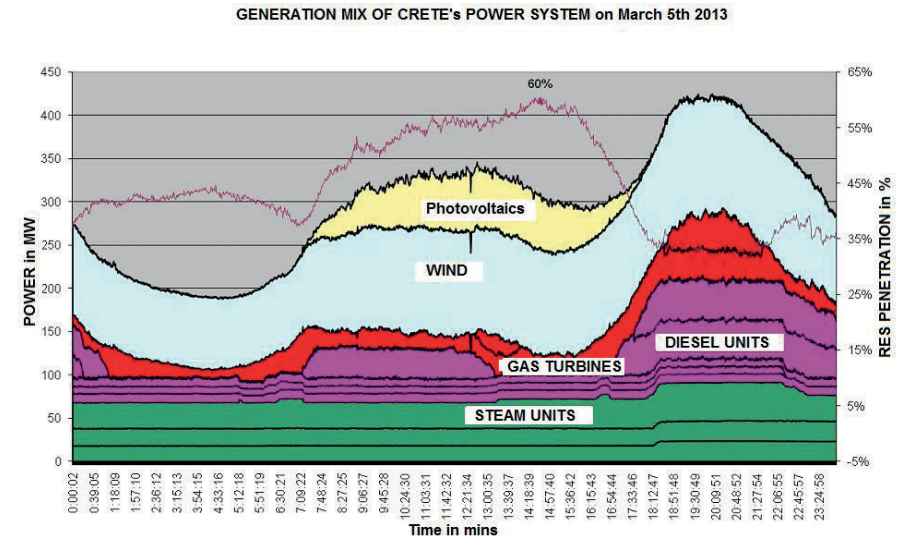

Figure 12: Generation mix for Crete's power system on 5/3/2013 and Renewables penetration (violet line) [45]

Energy storage

The coupling of energy storage with power generation from inherently intermittent sources, such as photovoltaic, is a key element of smart grids. A smart grid can be considered as an interconnection network between generation nodes, consumption nodes and a Point of Interconnection (POI), control node for smart grid regulation through the management of state variables. In order to maximize the grid performances, another control node can be considered in correspondence of Energy Storage System- ESS (Figure 13). In function of the specific requirements, voltage and frequency control rather than real and reactive power exchange could be considered as control parameters. Simultaneous management of PV and ESS allows smoothing the intermittency of PV generation and also to firm PV power generation (e.g. peak load reduction, market based dispatch).

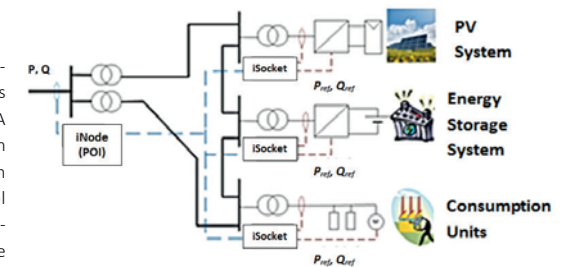

Figure 13: Smart grid architecture (based on [46])

For a proper operation of integrated system, all state parameters must be simultaneously monitored and regulated; therefore the appropriate communication between nodes must be assured at any given time. This condition can be satisfied only if all devices in the architecture (nodes) are capable to interoperate and they are also correctly synchronized.

Overview of storage technologies

Electrochemical batteries use chemical reactions, in two or more electrochemical cells, to create electric current by an oxidation-reduction process between the cell electrolyte and electrodes. Electrodes (anode and cathode) and electrolyte material, in mutual contact, constitute, along with the container, the primary element of a cell. Currently, the most used electrochemical energy storage devices, each based on a different specific chemical system, are: lead-based, lithium-based, nickel-based and sodium-based batteries. A schematic “qualitative” comparison among storage technologies is presented in Figure 14 which shows a good suitability for use with renewable sources of all electrochemical storage systems except supercapacitors.

APPLICATION	Hydro	CAES	Na/S	Na/NiCl ₂	Li/ion	Ni/Cd	Ni/MH	Pb/acido	Redox	Flywheel	SC
Time-shift	●	●	●	●	●	●	●	●	●	●	●
Renewable integration	●	●	●	●	●	●	●	●	●	●	●
Network investment deferral	●	●	●	●	●	●	●	●	●	●	●
Primary Regulation	●	●	●	●	●	●	●	●	●	●	●
Secondary Regulation	●	●	●	●	●	●	●	●	●	●	●
Tertiary Regulation	●	●	●	●	●	●	●	●	●	●	●
Power System Start-up	●	●	●	●	●	●	●	●	●	●	●
Voltage support	●	●	●	●	●	●	●	●	●	●	●
Power quality	●	●	●	●	●	●	●	●	●	●	●

● System suitable for the application ● System less suitable than others ● System not suitable for the application

Figure 14: Comparison among different electrochemical storage systems for the key grid applications [47], [48]

Even if electrochemical energy storage in batteries is an inherently mature technology, and widely used for more than a century, improvements are required for the integration with photovoltaics in electricity grids. Status of development of major electrochemical storage systems for this type of applications is reported in following Figure 15.

Status	Electrochemical Energy Storage
Mature	Lead-acid
Commercial	Lead-acid, NaS (sodium-sulphur)
Demonstration	ZnBr (zinc bromine), advanced lead-acid, VR (vanadium redox), NiMH (nickel-metal hydride), Li-ion (Lithium-ion)
Prototype	Li-ion, FeCr (Iron Chromium), ZEBRA (sodium nickel chloride = Na-NiCl ₂)
Laboratory	Zinc-air, advanced Li-ion, new electrochemical couples (other Lithium-based)
Idea -concept	Nano Supercapacitors, new electrochemical couples (metal-air, Na-ion, Mg-based and so on)

Figure 15: Development status of major electrochemical storage systems [47]

While batteries are most suitable for energy storage on an hourly and daily basis other energy storage solutions are more favorable for weekly or seasonal variations. Some examples of such storage solutions either in use or under development are hydro energy storage, compressed air storage or chemical storage (power to gas) [47].

Hydro energy storage can be based on either reservoir or pumped hydro storage. In pumped hydro storage turbines pump water into an upper reservoir for storage when excess electricity is available. When demand increases beyond production levels, water can be released through turbines for electricity production. Hydro storage is flexible and has a short response time, which makes it favorable in combination with intermittent energy sources. In compressed air storage electrical energy is stored by converting the electrical energy into potential energy of pressurized air and stored in this form in underground caverns or other pressure vessel. Chemical energy storage technology has been under rapid development in recent years. By using excess electricity for production of hydrogen (electrolysis) one achieves a flexible system where the produced hydrogen can be used for production of electricity into the grid or as fuel for the transport sector.

Combined PV + storage generating units

At the building level, local storage can be used to store PV electricity produced in excess of the current demand. If correctly sized, it enables controlling the level of active power injected into the grid while making use of all the potential PV production [49]. Both electrochemical storage and PV operate in Direct Current (DC) and an increasing share of the load in buildings (e.g., LED lighting, consumer electronics, computers) natively run on DC. As a result DC interconnection within buildings is getting traction [50]–[52].

The combination of smart storage systems and large photovoltaic systems can provide many functions at different levels of the electrical system, such as:

- ▶ Generation level: arbitrage, capacity firming, curtailment reduction.
- ▶ Customer level: peak shaving, time of use cost management, off-grid supply.
- ▶ Distribution level: voltage control, capacity support, curtailment reduction.
- ▶ Transmission level: frequency and voltage control, investment deferral, curtailment reduction, black starting; e.g.:
 - ▶ Regulation to respond to random, unpredictable variations in demand; unit must be able to respond in timescale seconds to minutes. In this case PV+storage is a source of generation but also it can be considered a reduction in load with conventional generators with positive impacts on daily cycling, and frequency regulation.
 - ▶ Contingency spinning reserve to respond to a contingency such as a generator failure; unit must begin responding immediately and be fully responsive within 10 minutes.
 - ▶ Replacement in case of the failure of a spinning unit into the network with a typical response time of 30-60 minutes.

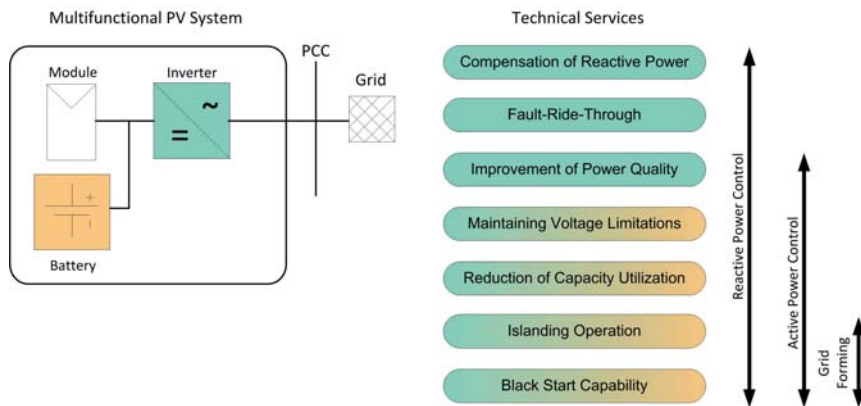

Figure 16: Technical services which can theoretically be offered by state-of-the-art PV and PV-battery systems [53]

Depending on integration level in electrical system, different rules and issues must be considered. For example, “large size PV + storage” integration into the grid is possible only by changing current operational methods with monitoring actions and remote control on wider scale unlike “small size PV + storage” that requires local-area supervision. Therefore the following aspects should be considered to apply combined storage+large-size-PV in electric grids:

- ▶ sizing of storage in function of PV plant and specific required functionalities (e.g. regulation within % band)
- ▶ design and testing of enabling technologies (e.g. smart devices for monitoring, control, communication of “storage + large-size-PV systems” with central grid control)
- ▶ modelling of new grid architectures to manage bidirectional flows (energy and information)- Figure 17
- ▶ cost-benefit analysis (e.g. fast-responding systems will add extra costs to the system)
- ▶ assessment of different e-market models
- ▶ definition of local/regional-specific guidelines for a regulatory framework in line with new business models

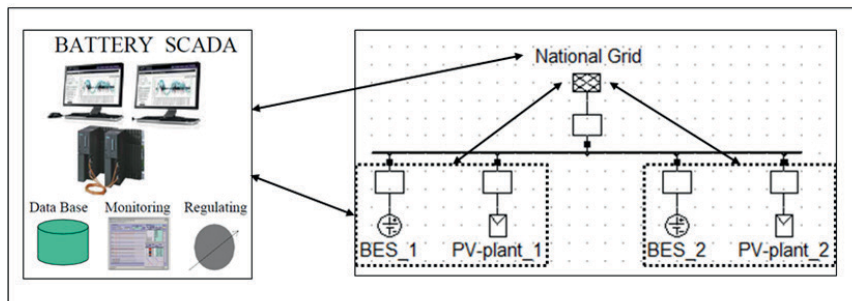

Figure 17: Conceptual scheme “storage + large-size-PV systems” [ENEA]

Micro-grids

A lot of research focuses on micro-grids [54] that aim to facilitate the integration of variable renewables and distributed generation units into the grids. Micro-grids consist of a combination of generation sources, loads and storage units that are connected to the distribution network through a single coupling point, and work – from the network perspective- as a single unit. A major characteristic of micro-grids is that they can operate either in parallel with the grid and in “island” mode (i.e. isolated from the grid) whenever this is required. Micro-grids can operate either in Alternating Current (AC) like the wider grids, or in Direct Current (DC). When the main network is not available, a local control system enables independent operation of the micro-grid. The required flexibility in energy management and control is ensured by the local control response of the distributed RES and storage grid-connected inverters, combined with that of controllable loads. The operation of a micro-grid as a single unit aims to avoid the negative impacts of distributed generation units on a centralized grid and turn them into positive impacts such as improved energy efficiency and local reliability, reduction of energy losses and need for grid expansion. Key challenges for the success of micro-grids are the development of appropriate control algorithms as well as protection and communication issues.

Small islands provide valuable fields for testing new technologies and operation modes for the integration of renewable in power grids. Islands have small, isolated power grids with often high share of renewable power. In principle, the electricity demand of a small island with a peak-load of a few hundreds kW could be fully met by renewables such as wind and PV power, with energy storage units to balance supply and demand. A proper design of the power system requires extensive simulation, and depends on load profile, wind and solar resources and the level of renewables penetration.

However, the achievement of a 100% renewable electricity penetration is usually difficult and costly as it involves oversized renewable power capacity and storage capacity. More affordable is to manage high shares of renewable electricity sources with appropriated energy storage and the use of back-up conventional power (e.g. diesel generators). The implementation of such systems requires bi-directional inverters as the interface between the energy storage units and the grid. Inverters are key components of the grid to ensure stable operation and provide dynamic balance of active and reactive power. The operation of such grids may also require renewable units to stop the production (if needed) on central operator’s request, along with a proper management of non-critical loads.

However, the number of these small-scale field applications with high share of renewables is currently low, and there are no standard solutions, technologies, and operating modes.

Enabling factors

Regulation

Successful integration of PV system into power grids will require a wide spectrum of regulatory measures.

From a technical standpoint, closer collaboration between PV producers and DSOs will be required to enable the participative definition of technical standards for integration.

From a market regulation point of view, tariff structures and metering schemes should be revised to meet the needs of an increasingly decentralised generation fleet while ensuring full implementation of the EU target model. Also, the flexibility of the current market design should be enhanced by reducing the duration of trading intervals and bringing gate closures closer to real time in order to allow PV systems to operate in full integration with power systems.

This evolution is complex. As institutional failure is common even much simpler contexts the risk of inappropriate regulatory evolution is real. It may be tempting for example to implement curtailment as an easier policy alternative to integration-enabling measures such as grid innovation, Demand-Side Management (DSM) and investment in adequate network infrastructure. Risk mitigation effort will therefore be required throughout the levels of policy making to ensure that a consistent and effective policy approach emerges.

From an early stage of technology development onwards, a risk mitigating approach will require a continuous adaptation of network codes and laws in regards to high national PV penetration scenarios. Neglecting the process of early adaptation will most likely result in high integration costs as retrofitting of existing PV systems will become necessary. Indeed, an initial grace period should be allowed to be better able to test actual potential and develop specific provisions for the system at regime, including adjusting existing regulation for other market components affected by the penetration of the hybrid technology. For instance, the increasing deployment of hybrid (PV+storage) technology might affect the competitiveness of existing PV-only systems with potentially negative impacts on their financial viability. Access to auxiliary service markets for PV producers – directly or through aggregators – could in this case help ensuring generators maximise the value of their production, which in turn occurs where appropriate pricing policies (real time pricing, pricing by service) are in place.

Net metering

In its simplest form, net metering consists in counting positively in the electricity bill the power drawn from the grid and negatively the power injected from the building, while keeping the same fee structure. This approach has been attacked by utilities, in

particular in the USA, for not providing adequate funding for the networks [55].

A more advanced net metering scheme has been implemented in Cyprus for residential systems up to 3 kWp. Its basic principle is that the electricity bill of a household is calculated every two months and is based on the net consumption – which is the difference between the energy consumed and energy produced of the household.

If the energy consumed is more than the energy produced for a specific bimonthly period, the net consumption will be positive and the customer has to pay the difference to the utility at retail price. On the other hand, if the energy produced is more than the energy consumed during the billing cycle, the net consumption will be negative thus the customer earns Renewable Energy Credits (RECs) which are credited on the customer's account to be used against any future positive net consumptions. In the meantime, the customer is obliged to pay the fixed capital cost to the utility for each bimonthly period. If any collected RECs remain at the end of each calendar year, these are passed over to the utility.

According to the regulator's decision 909/2013, prosumers i.e., customers with on-site generation capacity, must pay to the utility an annual fee of €37.03 per installed kWp (detailed analysis is shown in Table 1). Additionally, €2.19 per installed kWp is charged annually for the Public Support Fund and a fixed fee for RES support amounting €8.05 per installed kWp. By summing up all the aforementioned charges the total annual charge per installed kWp (without VAT) is €47.27.

The current net metering scheme is under investigation [56] by the Regulator with the intention of evaluating actual costs incurred by prosumers in order to identify realistic capacity charges and avoid cross subsidization.

Description	Debit €/kWp	Credit €/kWp
Operating expenses of Transmission System Operator (TSO-Cyprus)	1.48	
Ancillary Services	3.50	
Support of system for continuous supply of demand	13.82	
Charge for tertiary reserve	1.53	
Transmission Use of System Charge	3.98	
Distribution Use of System Charge – Medium Voltage	12.31	
Distribution Use of System Charge – Low Voltage	20.41	
Reduction due to less grid losses		20.00
Total amount for CERA's decision 909/2013	37.03	
Public Support Fund	2.19	
RES fund	8.05	
Total amount per year	47.27	

Table 1: Detailed analysis for net metering capacity charges per installed kWp

Communication standards

Interoperability is the capability of making systems work together. Therefore, apparatus and devices are able to interoperate if they can exchange information with other systems or services also from different manufacturers.

This characteristic is one of the basic requirements for open architectures in which systems and/or technologies, including management software, are capable to interact to share and use information. To date, PV and storage systems are not oriented towards information exchange since their management/control mechanisms (i.e. battery management systems) are generally not based on common communication protocols. So, to implement operative architectural solutions that include PV and storage

systems, some interoperability obstacles must be overcome:

- ▶ standards are not mature in all areas and, also in presence of mature standards, vendors may not have implemented them yet;
- ▶ “unique” reference standard is not present so even when vendor's equipment is compliant with a standard, it may not be interoperable with another vendor's equipment based on another standard protocol;
- ▶ interoperability problems can occur either when vendor equipment functionality are compliant with the most current standards or in absence of compliance [57].

In 2004, for example, the DOE (US Department of Energy) has established, the GWAC (GridWide Architecture Council). In 2009, NIST (National Institute of Standards and Technology) has released a preliminary set of 16 standards related to interoperability and later has founded a specific working group, SGIP (Smart Grid Interoperability Panel), with the main aim to encourage standard protocols adoption for devices design with particular reference to Smart Grid applications. Other SGIP main tasks are:

- ▶ identification of specific requirements for devices tests and their certification
- ▶ results dissemination
- ▶ creation of the “Catalog of Standards”, collection of standards for smart grid applications

Advanced Metering Infrastructure (AMI)

AMI is an infrastructure connecting metering devices in order to measure, collect, and analyze energy data with a fixed time step. In detail, AMI includes hardware and software resources (i.e. connection technologies to TCP/IP data network, generation/consumer unit controllers and displays, Meter Data Management software).

Application Programming Interface (API)

API, acronym for “Application Programming Interface”, are programs that allow to integrate non-compatible systems/devices by transforming and translating data from individual systems into a form suitable for feeding other systems.

API design consists, essentially, into the definition of a set of routines for building software interface applications between different devices. To this end, API are able to guarantee required interoperability only if based on open standards protocols, possibly free. In fact, only the adoption of open standards may push their adoption by the side of manufacturers also improving technological progress of all sectors, thanks to a wider use of programming languages for communication and data exchange.

Inverters

Inverter manufacturers are interested in communication features to their devices to better fit in the current smart grid initiatives. On the other hand, communication is going to be part of the grid connection requirements in Europe [42]. Manufacturers often have their own communication protocols and data formats, standardisation is important to have a common information model to ensure the interoperability and plug-and-play of PV plants. Current initiatives include IEC 61850-5 [58], IEEE 1547 [59], SunSpec [60].

Planning rules

Planning procedures for distribution grids can be improved using measured high-resolution load and PV profiles instead of synthetic profiles. Voltage variations should be estimated under different scenarios for planning the connection of PV systems on a three- or single-phase system [61]:

- ▶ Worst case: all PV systems on one phase, e.g. L1.
- ▶ Best case: ideal distribution over phases.
- ▶ Residual unbalance: distribution over phases as good as practically possible at each node; voltage variations are then calculated based on the remaining unbalance at each node.

Electric grids are planned to meet the changes from generation and demand based on prediction of operational scenarios in the future. In order to determine a cost-effective solution for reinforcement, operational scenarios with more PV plants need to take into account the control capabilities from PV and other emerging technologies. Such capabilities are in particular the provision of reactive power capabilities.

PV as building block of future power systems

Reduced investments in existing grids

Increased electrification of the energy system and ageing infrastructures require major grid upgrades in developed countries. PV systems can reduce the need for investment in power networks thanks to three characteristics:

- ▶ They are distributed and can produce electricity close to the point of use.
- ▶ In many locations, production occurs at times of high demand. As a result PV systems, when adequately installed, can improve power quality (in particular voltage levels) at no cost to the DSOs [47] in stressed areas.
- ▶ They are connected through active power converters (the inverters) which can support the local network even when the PV systems are not producing; an example is the compensation of reactive power through the so-called Q@night capability [63].

Currently, grid operators, both at transmission and distribution levels, have seen opportunities for utilising PV systems to solve different kinds of grid issues. Projects have been launched to develop solutions through technical and/or market measures [64].

Electrification through hybrid systems

Diesel generators are common in islands, in remote villages, where due to strong population growth electricity consumption is increasing and in remote industrial activities (for example mines). At the same time usually these remote locations have a significant solar potential. Over the past five years the cost of photovoltaic systems have been reduced dramatically and in the above cases the production of solar PV electricity cost is lower than diesel generation and depending on the installation location it could be in the range of 6 to 10 Euro cents per kWh over a system lifetime of 20 years. The cost per kilowatt hour of generated electricity with diesel engines essentially depends on the operating costs (diesel fuel, fuel transportation cost and maintenance) and in smaller measure on the costs of investment. The fuel costs between 20 and 30 Euro cents per kilowatt hour of electricity. Since the operating costs of photovoltaic systems are relatively low, the total costs of the hybrid system can thus be reduced. The focus when designing PV-diesel hybrid systems is to reduce the use of diesel fuel by contributing to the demand and even reducing the time period of operation of the diesel generators. At the same time, the stability and quality of the electricity supply must be guaranteed.

The PV-diesel hybrid system market could potentially become quite large. Although there has been a lot of fluctuations in the global sales of diesel generators in the past three years, it was nonetheless at a high level, rising from 38 GW in 2010 to nearly 48 GW in 2011, only to decline to 40 GW in 2012 and still remains at 40 GW in 2013 [65]. More than 50% of this quantity is usually accounted for by off-grid industrial plants or grids with frequent supply failures.

The document [66] builds on past work undertaken by IEA PVPS Task 9 experts and training sessions and field surveys undertaken in the framework of the CLUB-ER activities. The state of the art of PV-diesel hybrid systems for rural electrification is presented and the main issues to address such as, the design, technical and implementation perspectives are highlighted. Guidance is provided to enable sound decision making when considering solar PV hybrid systems to address rural electrification needs. In Figure 18 the market segmentation for PV-diesel hybrid systems for rural electrification in developing countries is presented (type of system with upfront investment cost).

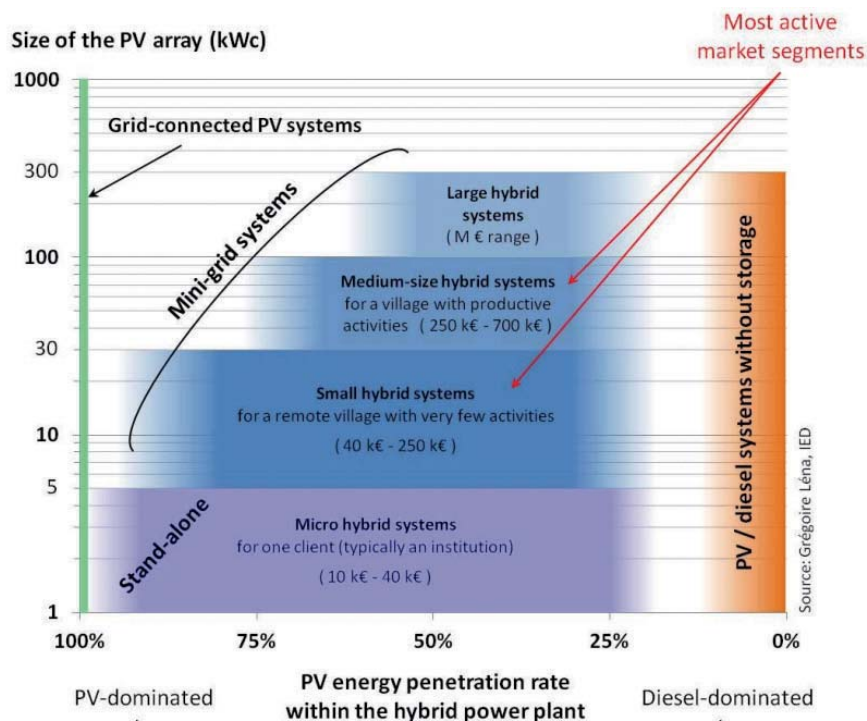

Figure 18: Market segmentation for PV-diesel hybrid systems [66]

Conclusion

Although progress has been made in enabling PV integration over the past few years there is still a lot of room for improvement and solutions are reachable. Constructive co-operation between utilities, governments, regulators, and the PV industry is needed. An encouraging sign is the good alignment between the views of the Smart Grid Technology Platform, where DSOs play an important role, and those of the PV Technology Platform.

Grids can sustain unrestricted penetration of distributed generation provided that quality of supply is addressed at connection point through the capabilities of modern power electronics and distributed control. Ancillary services can fully complement faultless commitment of distributed, renewable energy sources in line with market requirements.

While the qualitative impact of PV on electric grids and of various technical approaches are clear, solid quantification is missing. More research is urgently needed to quantify both the achievable levels of PV penetration and the increase potential that existing concepts enable. Too often the integration of PV into power systems is seen as a threat to stability or affordability. We would like to highlight the opportunities that this integration represents. Indeed, PV systems can provide ancillary services and reduce the need for grid reinforcement in the face of increasing demand. At the centre of this potential lie advanced inverters and hybrid systems which combine PV with stationary storage or other power sources.

References

- [1] K. Kaneko, "Kyushu Electric Announces Details of Its PV Output Reduction Policy," *Solar Power Plant Business*, 26-Dec-2014. [Online]. Available: http://techon.nikkeibp.co.jp/english/NEWS_EN/20141226/396546/?ST=msbe. [Accessed: 15-Jan-2015].
- [2] FS-UNEP Collaborating Centre for Climate & Sustainable Energy Finance and Bloomberg New Energy Finance, "Global Trends in Renewable Energy Investment 2014," Frankfurt School of Finance & Management GmbH, Frankfurt am Main, Germany, 2014.
- [3] REN21, "Renewables 2014 Global Status Report," REN21 Secretariat, Paris, France, 2014.
- [4] E.ON, "New corporate strategy: E.ON to focus on renewables, distribution networks, and customer solutions and to spin off the majority of a new, publicly listed company specializing in power generation, global energy trading, and exploration and production," E.ON SE, Düsseldorf, Germany, Press release, Nov. 2014.
- [5] M. Antal, G. Concas, E. Despotou, A. El Gammal, D. Fraile Montoro, M. Latour, P. Llamas, S. Lenoir, G. Masson, P. Van Bugghenout, S. Teske, S. Rolland, and R. Short, "Solar Generation 6," European Photovoltaic Industry Association, Brussels, Belgium, Oct. 2010.
- [6] T. Stetz, M. Kraiczky, K. Diwold, M. Braun, B. Bletterie, C. Mayr, R. Bründlinger, B. Noone, A. Bruce, I. MacGill, B. Mather, K. Ogimoto, K. Washihara, A. Iaria, A. Gatti, D. Cirio, M. Reking, I. T. Theologitis, K. de Brabandere, S. Tselepis, C. Bucher, and Y. Wang, "High Penetration PV in Local Distribution Grids - Outcomes of the IEA PVPS Task 14 Subtask 2," presented at the 2014, Amsterdam, 25-Sep-2014.
- [7] G. Masson, S. Orlandi, M. Reking, and B. Fontaine, "Global market outlook for photovoltaics: 2014-2018," European Photovoltaic Industry Association, Brussels, Belgium, ISBN 9789082228403, Jun. 2014.
- [8] A. G. Martinez, "Challenges for a TSO with large installed renewable energy," presented at the Network operation under high intermittent power generation, Bern, Switzerland, 28-Apr-2011.
- [9] European Commission, "EU Energy in figures: statistical pocketbook 2014," Publications Office of the European Union, Luxembourg, ISBN 978-92-79-29317-7, 2014.
- [10] N. Efkarpidis, C. Gonzalez, T. Wijnhoven, D. Van Dommelen, T. De Rybel, and J. Driesen, "Technical Assessment of On-Load Tap-Changers in Flemish LV Distribution Grids," presented at the 3rd International Workshop on Integration of Solar Power into Power Systems, London, UK, 2013.
- [11] Direzione mercati, "Testo unico ricognitivo dell produzione elettrica," Autorità per l'energia elettrica il gas e il sistema idrico, Milan, Italy, May 2014.
- [12] A. Constantin, R. Dan Lazar, and S. Bækthøj Kjær, "Voltage control in low voltage networks by Photovoltaic Inverters - PVNET.dk," Danfoss Solar Inverters A/S, Case study, Dec. 2012.
- [13] J. Kathan, "Increasing the Hosting Capacity of PV with storage systems," presented at the EERA Smart Grid R&D Workshop, Milan, Italy, 28-Jun-2012.
- [14] J. Smith, M. Rylander, and C. Trueblood, "PV Hosting Capacity in Electric Distribution: Monitoring and Feeder Analysis Results from the US," presented at the 5th International Conference on Integration of Renewable and Distributed Energy Resources, Berlin, Germany, 04-Dec-2012.
- [15] M. Patsalides, G. E. Georghiou, A. Stavrou, and V. Efthymiou, "Assessing the power quality behaviour of high photovoltaic (PV) penetration levels inside the distribution network," Proc. - 2012 3rd IEEE Int. Symp. Power Electron. Distrib. Gener. Syst. PEDG 2012, pp. 709-716, 2012.
- [16] A. Klajn and M. Bątkiewicz-Pantula, "Standard EN 50160: Voltage characteristics of electricity supplied by public electricity networks," European Copper Institute, Application Note Cu0147, Mar. 2013.
- [17] A. Navarro, P. Mancarella, L. F. Ochoa, and D. Randles, "Impacts of photovoltaics on low voltage networks: A case study for the North West of England," presented at the 22nd International Conference and Exhibition on Electricity Distribution (CIRED 2013), Stockholm, Sweden, 2013.
- [18] E. Romero-Cadaval, G. Spagnuolo, L. Garcia Franquelo, C. A. Ramos-Paja, T. Suntio, and W. M. Xiao, "Grid-Connected Photovoltaic Generation Plants: Components and Operation," *IEEE Ind. Electron. Mag.*, vol. 7, no. 3, pp. 6-20, 2013.
- [19] F. Iov, M. Ciobotaru, D. Sera, R. Teodorescu, and F. Blaabjerg, "Power Electronics and Control of Renewable Energy Systems," in 7th International Conference on Power Electronics and Drive Systems, 2007. PEDS '07, 2007, p. P-6-P-28.
- [20] M. Juamperez, G. Yang, and S. B. Kjær, "Voltage regulation in LV grids by coordinated volt-var control strategies," *J. Mod. Power Syst. Clean Energy*, pp. 1-10, Sep. 2014.
- [21] J. H. Eto, J. Undrill, P. Mackin, R. Daschmans, B. Williams, B. Haney, R. Hunt, J. Ellis, H. Illian, C. Martinez, M. O'Malley, K. Coughlin, and K. H. LaCommare, "Use of Frequency Response Metrics to Assess the Planning and Operating Requirements for Reliable Integration of Variable Renewable Generation," Lawrence Berkeley National Laboratory, Berkeley, California, USA, LBNL-4142E, Dec. 2010.
- [22] B. Krummen, "Le défi de l'augmentation de l'injection PV du point de vue des gestionnaires de réseaux de distribution," presented at the 12ème congrès national photovoltaïque, Lausanne, Switzerland, 10-Apr-2014.
- [23] International Energy Agency, "The Power of Transformation: Wind, Sun and the Economics of Flexible Power Systems," International Energy Agency, Paris, France, ISBN 978-92-64-20802-5, 2014.
- [24] M. Reking, I.-T. Theologitis, G. Masson, M. Latour, D. Biancardi, A. Roesch, G. Concas, and P. Basso, "Connecting the sun: solar photovoltaics on the road to large-scale grid integration," European Photovoltaic Industry Association, Brussels, Belgium, Full report, Sep. 2012.
- [25] I. Koumparou, M. Hadjipanayi, A. Charalambous, O. Kyriacou, and G. E. Georghiou, "Promotion of PV energy through net metering optimization (PV-NET): the case of Cyprus," presented at the 9th International Conference on Deregulated Electricity Market Issues in South Eastern Europe (DEMSEE), Nicosia, Cyprus, 2014, p. 38.
- [26] M. Milligan, E. Ela, B.-M. Hodge, B. Kirby, D. Lew, C. Clark, J. DeCesaro, and K. Lynn, "Integration of Variable Generation, Cost-Causation, and Integration Costs," *Electr. J.*, vol. 24, no. 9, pp. 51-63, Nov. 2011.
- [27] H. Holttinen, P. Meibom, A. Orths, B. Lange, M. O'Malley, J. O. Tande, A. Estanqueiro, E. Gomez, L. Söder, G. Strbac, J. C. Smith, and F. van Hulle, "Impacts of large amounts of wind power on design and operation of power systems, results of IEA collaboration," *Wind Energy*, vol. 14, no. 2, pp. 179-192, Mar. 2011.
- [28] W. Katzenstein and J. Apt, "The cost of wind power variability," *Energy Policy*, vol. 51, pp. 233-243, Dec. 2012.
- [29] M. Milligan and B. Kirby, "Calculating Wind Integration Costs: Separating Wind Energy Value from Integration Cost Impacts," National Renewable Energy Laboratory, Golden, Colorado, USA, Technical Report NREL/TP-550-46275, Jul. 2009.
- [30] D. Pudjianto, P. Djapic, J. Dragovic, and G. Strbac, "Direct Cost Analysis related to Grid Impacts of Photovoltaics," *PV Parity*, Sep. 2013.
- [31] T. Stetz, "Autonomous Voltage Control Strategies in Distribution Grids with Photovoltaic Systems: Technical and Economic Assessment," PhD thesis, Universität Kassel, 2013.
- [32] T. Stetz, K. Diwold, M. Kraiczky, D. Geibel, S. Schmidt, and M. Braun, "Techno-Economic Assessment of Voltage Control Strategies in Low Voltage Grids," *IEEE Trans. Smart Grid*, vol. 5, no. 4, pp. 2125-2132, Jul. 2014.
- [33] G. Kerber, "Aufnahmefähigkeit von Niederspannungsverteilnetzen für die Einspeisung aus Photovoltaikkleinanlagen," PhD thesis, Technische Universität München, München, 2011.
- [34] M. Braun, T. Stetz, T. Reimann, B. Valov, and G. Arnold, "Optimal Reactive Power Supply in Distribution Networks- Technological and Economic Assessment for PV-Systems," presented at the 24th European Photovoltaic Solar Energy Conference, Hamburg, Germany, 2009, pp. 3872 - 3881.
- [35] D. Mende, Y. T. Fawzy, D. Premm, and S. Stevens, "Increasing the Hosting Capacity of Distribution Networks for Distributed Generation Utilizing Reactive Power Control - Potentials and Limits," presented at the 2nd International Workshop on Integration of Solar Power into Power Systems, Lisbon, Portugal, 2012.
- [36] C. Bucher, G. Andersson, and L. Küng, "Increasing the PV Hosting Capacity of Distribution Power Grids - A Comparison of Seven Methods," presented at the 28th European Photovoltaic Solar Energy Conference and Exhibition, Paris, France, 2013, pp. 4231 - 4235.
- [37] B. Bletterie, A. Gorsek, B. Uljanic, B. Blazic, A. Woyte, T. Vu Van, F. Truysens, and J. Jahn, "Enhancement of the Network Hosting Capacity - Clearing Space for/with PV," presented at the 25th European Photovoltaic Solar Energy Conference and Exhibition / 5th World Conference on Photovoltaic Energy Conversion, Valencia, Spain, 2010, pp. 4828 - 4834.
- [38] BDEW, "Generating Plants Connected to the Medium-Voltage Network: Guideline for generating plants' connection to and parallel operation with the medium-voltage network," BDEW Bundesverband der Energie- und Wasserwirtschaft e.V., Berlin, Germany, Technical Guideline, Jun. 2008.

- [39] Forum Netztechnik Netzbetrieb, "Power generation systems connected to the low-voltage distribution network: Technical minimum requirements for the connection to and parallel operation with low-voltage distribution networks," VDE, Berlin, Germany, Application Guide VDE-AR-N 4105:2011-08, Aug. 2011.
- [40] P. Esslinger, "Studie Q(U)," Technische Universität München, München, Germany, Aug. 2012.
- [41] B. Bletterie, A. Stojanovic, S. Kadam, G. Lauss, M. Heidl, C. Winter, D. Hanek, A. Pamer, and A. Abart, "Local Voltage Control by PV Inverters: First Operating Experience from Simulation, Laboratory Tests and Field Tests," presented at the 27th European Photovoltaic Solar Energy Conference and Exhibition, Frankfurt-am-Main, Germany, 2012, pp. 4574 – 4581.
- [42] "Network Code on Requirements for Grid Connection Applicable to all Generators (RfG)," ENTSO-E, 11-Apr-2013. [Online]. Available: <https://www.entsoe.eu/major-projects/network-code-development/requirements-for-generators/Pages/default.aspx>. [Accessed: 10-Sep-2014].
- [43] M. Patsalides, V. Efthymiou, A. Stavrou, and G. E. Georghiou, "Simplified distribution grid model for power quality studies in the presence of photovoltaic generators," IET Renew. Power Gener., pp. 1–11, 2015.
- [44] R. Perez, E. Lorenz, S. Pelland, M. Beauharnois, G. Van Knowe, K. Hemker Jr., D. Heinemann, J. Remund, S. C. Müller, W. Traunmüller, G. Steinmayer, D. Pozo, J. A. Ruiz-Arias, V. Lara-Fanego, L. Ramirez-Santigosa, M. Gaston-Romero, and L. M. Pomares, "Comparison of numerical weather prediction solar irradiance forecasts in the US, Canada and Europe," Sol. Energy, vol. 94, pp. 305–326, Aug. 2013.
- [45] J. Nikolettos and S. Tselepis, "Renewable Integration in Power Grids," IEA Energy Technology Systems Analysis Programme (ETSAP), Technology Brief E15, Dec. 2013.
- [46] "Energy storage systems integration into PV power plants," GPTech, 26-Feb-2014. [Online]. Available: <http://www.greenpower.es/en/communication/new-detail/Energy-storage-systems-integration-into-PV-power-plants/#prettyPhoto>. [Accessed: 06-Jan-2015].
- [47] O. Teller, J.-P. Nicolai, M. Lafoz, D. Laing, R. Tamme, A. Schroder Pedersen, M. Andersson, C. Folke, C. Bourdil, M. Conte, G. Gigliucci, I. Fastelli, M. Vona, M. Rey Porto, T. Hackensellner, R. Kapp, C. Ziebert, H. J. Seifert, M. Noe, M. Sander, J. Lugaro, M. Lippert, P. Hall, R. Saliger, A. Harby, M. Pihlatie, N. Omar, J.-M. Durand, M. J. Duarte, and P. Clerens, "Joint EASE/EERA recommendations for a European energy storage technology development roadmap towards 2030," European Association for Storage of Energy (EASE), Brussels, Belgium, Mar. 2013.
- [48] Ricerca sul Sistema Energetico - RSE SpA, L'accumulo di energia elettrica. Milan, Italy: Il Melograno Editore srl, 2011.
- [49] J. von Appen, A. U. Schmiegel, and M. Braun, "Impact of PV Storage Systems on Low Voltage Grids – A Study on the Influence of PV Storage Systems on the Voltage Symmetry of the Grid," presented at the 27th European Photovoltaic Solar Energy Conference and Exhibition, Frankfurt am Main, Germany, pp. 3822–3828.
- [50] EMerge Alliance, "380Vdc Architectures for the Modern Data Center," EMerge Alliance, San Ramon, CA, USA, 2013.
- [51] The IET, "Code of Practice for low and extra low voltage direct current power distribution in buildings," The IET, London, UK, Draft for Comment, Oct. 2014.
- [52] USB Implementers Forum Inc., "USB Power Delivery," USB.org. [Online]. Available: <http://www.usb.org/developers/powerdelivery/>. [Accessed: 22-Oct-2013].
- [53] K. Büdenbender, M. Braun, T. Stetz, and P. Strauss, "Multi-functional PV Systems Offering Additional Functionalities and Improving Grid Integration," Int. J. Distrib. Energy Resour., vol. 7, no. 2, pp. 109–128, 2011.
- [54] N. Hatzigiorgiari, H. Asano, R. Iravani, and C. Marnay, "Microgrids," IEEE Power Energy Mag., vol. 5, no. 4, pp. 78–94, Jul. 2007.
- [55] C. Martin and C. Chediak, "California Utilities Say Solar Raises Costs for Non-Users," Bloomberg.com, 17-Dec-2012. [Online]. Available: <http://www.bloomberg.com/news/articles/2012-12-17/california-utilities-say-solar-raises-costs-for-non-users>.
- [56] N. Philippou, V. Efthymiou, M. Hadjipanayi, I. Papageorgiou, C. Zannettis, M. Delenta, C. Karayiannis, C. Eliopoulos, M. Ioannidou, C. Themistocleous, E. Loucaidou, X. Valanidou, T. Mesimeris, and G. E. Georghiou, "Smart net metering for promotion and cost-efficient grid-integration of PV technology in Cyprus (SmartPV)," presented at the 9th International Conference on Deregulated Electricity Market Issues in South Eastern Europe, Nicosia, Cyprus, 2014, p. 37.
- [57] J. Hawkins, "System Integration of Utility-Scale PV Plus Battery Storage: Interoperability and 'Lessons Learned,'" Smart Grid Interoperability Panel (SGIP), Case study, May 2014.
- [58] TC 57, "Communication networks and systems for power utility automation – Part 5: Communication requirements for functions and device models," International Electrotechnical Commission, Geneva, Switzerland, International standard IEC 61850-5, Jan. 2013.
- [59] IEEE SCC21, "Interconnecting Distributed Resources with Electric Power Systems," IEEE, IEEE Standard 1547-2003, Jul. 2003.
- [60] SunSpec Alliance, "SunSpec Alliance: Information Standards for Distributed Energy," SunSpec Alliance, San Jose, CA, USA, May 2014.
- [61] M. Heidl, C. Winter, D. Hanek, B. Bletterie, S. Kadam, A. Abard, E. Traxler, and K. Leeb, "morePV2grid: More functionalities for increased integration of PV into grid," Klima- und Energiefonds, Vienna, Austria, 6/2013, 2013.
- [62] W. Urbey, T. F. Araujo, F. Preisser, S. R. Silva, E. N. Cardoso, and B. M. Lopes, "Assessing the Value of Distributed Photovoltaic Distribution System," presented at the 3rd Renewable Power Generation Conference, Naples, Italy, 2014.
- [63] SMA, "Q at Night: Reactive power outside feed-in operation with the Sunny Central series CP XT, CP-JP and CP-US," SMA Solar Technology AG, Niestetal, Germany, Technical Information Q-at-Night-TI-en-11, 2011.
- [64] C. Felix Covrig, M. Ardelean, J. Vasiljevskva, A. Mengolini, G. Fulli, E. Amoiralis, M. Sánchez Jiménez, C. Filiou, and European Commission, "Smart grid projects outlook 2014," Publications Office of the European Union, Luxembourg, JRC Science and Policy Reports EUR 26 651 EN, 2014.
- [65] B. Haight, "38th Power Generation Order Survey," Diesel & Gas Turbine Worldwide, May 2014.
- [66] G. Léna, "Rural Electrification with PV Hybrid Systems: Overview and Recommendations for Further Deployment," International Energy Agency, IEA-PVPS T9-13:2013, Jul. 2013.

Acronyms

AC	Alternating Current
AMI	Advanced Metering Infrastructure
API	Application Programming Interface
DC	Direct Current
DOE	US Department of Energy
DSM	Demand Side Management
DSO	Distribution System Operator
ESS	Energy Storage System
GWAC	Grid Wise Architecture Council
IEA	International Energy Agency
LCoE	Levelised Cost of Electricity
NIST	National Institute of Standard and Technology
NWP	Numerical Weather Prediction
Pol	Point of Interconnection
PV	Photovoltaics
REC	Renewable Energy Credit
SGIP	Smart Grid Interoperability Panel
THD	Total Harmonic Distortion
TSO	Transmission System Operator
VRE	Variable Renewable Energy



www.eupvplatform.org