

Technical University of Denmark



A reinforcement system and a method of reinforcing a structure with a tendon

Schmidt, Jacob Wittrup; Schmidt, Jacob Wittrup

Publication date:
2016

Document Version
Publisher's PDF, also known as Version of record

[Link back to DTU Orbit](#)

Citation (APA):
Schmidt, J. W., & Schmidt, J. W. (2016). IPC No. E04C 5/ 07 A I. A reinforcement system and a method of reinforcing a structure with a tendon (Patent No. WO2016079214.)

DTU Library

Technical Information Center of Denmark

General rights

Copyright and moral rights for the publications made accessible in the public portal are retained by the authors and/or other copyright owners and it is a condition of accessing publications that users recognise and abide by the legal requirements associated with these rights.

- Users may download and print one copy of any publication from the public portal for the purpose of private study or research.
- You may not further distribute the material or use it for any profit-making activity or commercial gain
- You may freely distribute the URL identifying the publication in the public portal

If you believe that this document breaches copyright please contact us providing details, and we will remove access to the work immediately and investigate your claim.



- (51) **International Patent Classification:**
E04C 5/12 (2006.01) *E04C 5/07* (2006.01)
- (21) **International Application Number:**
PCT/EP2015/077040
- (22) **International Filing Date:**
19 November 2015 (19.11.2015)
- (25) **Filing Language:** English
- (26) **Publication Language:** English
- (30) **Priority Data:**
14194291.2 21 November 2014 (21.11.2014) EP
- (71) **Applicant:** DANMARKS TEKNISKE UNIVERSITET
[DK/DK]; Anker Engelunds Vej 101 A, DK-2800 Kgs.
Lyngby (DK).
- (72) **Inventor:** SCHMIDT, Jacob Wittrup; Vejlegade 6, 1.-5,
DK-2100 Copenhagen Ø (DK).
- (74) **Agent:** GUARDIAN IP CONSULTING I/S; Diplomvej,
Building 381, DK-2800 Kgs. Lyngby (DK).
- (81) **Designated States** (unless otherwise indicated, for every
kind of national protection available): AE, AG, AL, AM,

AO, AT, AU, AZ, BA, BB, BG, BH, BN, BR, BW, BY,
BZ, CA, CH, CL, CN, CO, CR, CU, CZ, DE, DK, DM,
DO, DZ, EC, EE, EG, ES, FI, GB, GD, GE, GH, GM, GT,
HN, HR, HU, ID, IL, IN, IR, IS, JP, KE, KG, KN, KP, KR,
KZ, LA, LC, LK, LR, LS, LU, LY, MA, MD, ME, MG,
MK, MN, MW, MX, MY, MZ, NA, NG, NI, NO, NZ, OM,
PA, PE, PG, PH, PL, PT, QA, RO, RS, RU, RW, SA, SC,
SD, SE, SG, SK, SL, SM, ST, SV, SY, TH, TJ, TM, TN,
TR, TT, TZ, UA, UG, US, UZ, VC, VN, ZA, ZM, ZW.

(84) **Designated States** (unless otherwise indicated, for every
kind of regional protection available): ARIPO (BW, GH,
GM, KE, LR, LS, MW, MZ, NA, RW, SD, SL, ST, SZ,
TZ, UG, ZM, ZW), Eurasian (AM, AZ, BY, KG, KZ, RU,
TJ, TM), European (AL, AT, BE, BG, CH, CY, CZ, DE,
DK, EE, ES, FI, FR, GB, GR, HR, HU, IE, IS, IT, LT, LU,
LV, MC, MK, MT, NL, NO, PL, PT, RO, RS, SE, SI, SK,
SM, TR), OAPI (BF, BJ, CF, CG, CI, CM, GA, GN, GQ,
GW, KM, ML, MR, NE, SN, TD, TG).

Published:

— without international search report and to be republished
upon receipt of that report (Rule 48.2(g))

(54) **Title:** A REINFORCEMENT SYSTEM AND A METHOD OF REINFORCING A STRUCTURE WITH A TENDON

Fig. 1

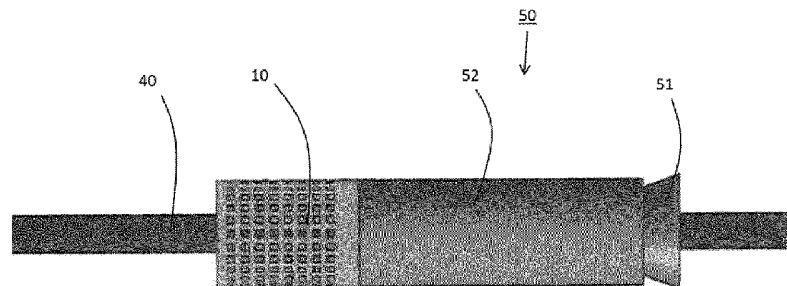

(57) **Abstract:** A reinforcement system for anchoring tendons for structural reinforcing a structure such as a concrete structure, said reinforcement system comprises at least one anchor and at least one tendon, said anchor is adapted to fix said tendon in and/or out-side said structure, wherein said reinforcement system comprises a ductility element, which is positioned in structural connection between said tendon and said anchor, said ductility element comprising weakened deformation zones being deformable so that the length of the ductility is increased or decreased in an axial direction along the length of said tendon.

WO 2016/079214 A2

A reinforcement system and a method of reinforcing a structure with a tendon

The present invention relates to a reinforcement system for anchoring tendons for structural reinforcing a structure such as a concrete structure, said reinforcement system comprises at least one anchor and at least one tendon, said anchor is
5 adapted to fix said tendon in and/or outside said structure.

Background of the invention

Ductility of structures is important to ensure large deformation and give sufficient
10 warning while maintaining an adequate load capacity before structure failure. Concrete is a brittle material. Concrete structures rely largely on the deformation and yielding of the tensile reinforcement to satisfy the ductility demand.

The application of high strength steel reinforcement in concrete structures has less
15 ductility due to the lower degree of strain hardening and smaller elongation of the tensile reinforcement.

The application of fiber reinforced polymer (FRP) reinforcement has a similar
20 problem, as FRP have a low strain capacity and linear elastic stress-strain behavior up to rupture without yielding.

Thus, the ductility of concrete members reinforced with non-ductile tendons, especially FRP reinforced concrete members, decreases due to the tensile reinforcement deforms less and hence a lower deformability and ductility is
25 achieved.

US2014/0123593 discloses a method of improving the ductility of a structural member, such as a reinforced concrete beam or column reinforced by tensile members made of high strength steel or FRP, by providing a region of increased
30 compression yielding in the compression zone of a plastic hinge region or nearby. This can be achieved by forming a mechanism provided in the compression zone to provide the ductile compression zone.

US6082063 discloses an anchorage for a tendon that includes a sleeve having a smooth tapered interior bore and a compressible wedge disposed in the sleeve. The compressible wedge has a smooth exterior tapered surface tapering from a wider end to a narrower end and one or more interior channels for receiving a tendon.

5 The taper angle of the compressible wedge is greater than the taper angle of the bore. Thus, upon insertion of the compressible wedge into the sleeve, the wider end of the compressible wedge forms a wedge contact with the sleeve before the narrower end forms a wedge contact with the sleeve. Hereby is achieved an appropriate anchorage system for FRP tendons.

10

In many cases, it is desirable to provide an improved structural ductility of high strength steel or FRP reinforced concrete members.

Brief description of the invention

15

It is an object of the present invention is to provide an improved ductility of reinforced structural members.

20

This is achieved by said reinforcement system comprises a ductility element, which is positioned in structural connection between said tendon and said anchor, said ductility element comprising weakened deformation zones, said weakened deformation zones are configured for increasing the ductility of said reinforcement system, said weakened deformation zones being deformable and thereby said weakened deformation zones are configured for allowing the length of deformation zones on the ductility element to increase or decrease in an axial direction along the length of said tendon, when the stress on the ductility element exceeds a certain level.

25

30

This results in the ductility element by elongation or compression increases the ductility in the reinforcement system.

In an embodiment, said ductility element comprises multiple deformable zone positioned subsequent in an axial direction along the length of said tendon, thus providing subsequent deformable zones, enabling a sequence of ductility.

5 Hereby is achieved that each deformation zone, when it collapses, only gives rise to a limited length reduction of the complete ductility element, and thereby the ductility element can initially adapt to small variations in the mounting of the tendon and the anchor, and thereafter provide the required ductility due to the remaining undeformed deformation zones.

10

In an embodiment, the ductility element comprises a through going channel, said through going channel being disposed internally within the one or more deformable zones for receiving said tendon, the through going channel being disposed such that the tensile force on the tendon during use are oriented along the extension of
15 the through going channel.

Hereby is achieved that all the deformation zones are subjected to the same force applied by the stress in the tendon, and the weakest deformation zone will thereby collapse first.

20

In an embodiment, the reinforcement system is configured such that the force required for deformation of the ductility element in axial load is less than the force required for deformation of the tendon.

25 In an embodiment, the ductility element is configured such that the force required for deformation of the ductility element in axial load being about 30-95%, preferably 70-95 % of the force required for deformation of said tendon.

In an embodiment, the ductility element is an integrated part of said anchor.

In a further embodiment, said ductility element comprises a circular cross section
30 and said anchor comprises a barrel having a smooth tapered interior bore and a compressible wedge adapted to be disposed in said barrel.

In a further embodiment, said ductility element is positioned at one extremity of said anchor as an extension of the barrel.

5 In another embodiment, said ductility element comprises a rectangular cross section and said internal channel comprises a rectangular cross section for the lead through of a tendon having a corresponding rectangular cross section.

The present invention further relates to a method of reinforcing a structure with a tendon, comprising fixing the tendon to the structure at different positions, and
10 where the tendon is fixed to the structure by using ductility elements at each position, and where each ductility element is weakened at local deformation zones, and thereby deforms when the stress on the ductility element exceeds a certain level so that the length of the deformation zone on the ductility element is increased or decreased in an axial direction along the length of said tendons.

15

The term tendon should be understood as any type of reinforcement element of steel or fibers, such as FRP cable or rods, e.g. carbon, aramid or glass fiber reinforced polymer, although other material also may be used.

Brief description of the drawings

20 Embodiments of the invention will be described in the following with reference to the drawings wherein

Fig. 1 illustrates a ductility element in connection with a barrel and wedge anchor,

Fig. 2 is a schematic view of a ductility element,

Fig. 3 is a schematic view of a ductility element, a cross sectional view of the
25 ductility element in a line indicated by B, and an end view of the ductility element,

Fig. 4 is a perspective view of a T-shaped structure,

Fig. 5 is a side view of the T-shaped structure shown in figure 4,

Fig. 6 is a schematic side view of another embodiment of a ductility element,

Fig. 7 is a side view and a top view of the ductility element illustrated in fig. 5,

Fig. 8 is a perspective view of a T-shaped structure,

Fig. 9 illustrates a bottom view of the T-shaped structure illustrated in fig. 7, and a cross sectional view of the T-shaped structure in the line indicated by H, the sub

5 section of the T-structure indicated by J is illustrated in fig. 9 in an enlarged view,

Fig. 10 is an enlarged side view of the sub section of the cross sectional view of the T-shaped structure which is shown in fig 8, in fig. 8 the sub section is indicated by J,

Fig. 11 illustrates three embodiments of the ductility element.

10

Detailed description of the invention with reference to the figures

The present invention relates to a reinforcement system for anchoring tendons for structural reinforce a structure such as a concrete structure.

15 Figure 1 illustrates a reinforcement system which comprises an anchor (50) adapted to fasten a tendon and a ductility element (10) within a structure.

The anchor (50) is schematically illustrated as a known type of an anchor comprising a barrel (52) and wedge (51), wherein the barrel has a tapered interior
20 bore and the compressible wedge being adapted to be coaxially disposed in the barrel. The tendon (40) extends through the center of the wedge, which is wedged coaxially inside the barrel for clamping the tendon (40), and thereby anchoring the tendon in a structure.

25 Furthermore, the reinforcement system comprises a ductility element (10), which is positioned in structural connection between said tendon (40) and said anchor (50), said ductility element comprises weakened deformation zones being deformable in axial direction along the length of said tendons. The deformation zones are weakened in relation to the other part of the ductility element.

30

The ductility element is configured such that the force required for deformation of the ductility element in axial load is less than the force required for deformation of the tendon. Thus, the ductility element (10) has a ductile phase in axial load less than the tensile strength of the tendons, thus making the ductility element the
5 weakest link in the reinforcement system. The ductility element (10) will reach its strength before the other components of the reinforcement system. When the stress exceeds the threshold of the ductility of the ductility element, the ductility element will deform and it thus provide ductility to the reinforcement system.

10 As concrete is a brittle material. Concrete structures rely on the deformation and yielding of the tensile reinforcement to satisfy the ductility demand.
By employing a ductility element in combination with tendons made of high strength steel or fiber lacking of sufficient ductility by allowing the ductility element to deform and thus provide an increased ductility.

15

Figure 2 illustrates a first embodiment of the ductility element (10).

The ductility element comprises a first end (11), a second end (12), two deformable walls (14,16) and a through going channel (13) adapted for receiving a tendon, the
20 through going channel extends centrally internal through said ductility element, from said first end (11) to the far side of the second end (12) thereby both deformable walls are subjected to the same force applied by the stress in the tendon, and the weakest one will thereby collapse first.

25 The two deformable walls (14,16) are divided into sequential zones by a partition (15).

As the two deformable walls (14,16) has varying thickness enables the ductility element to deform upon loads, and as illustrated in figure 2, the weakened
30 deformable walls are able to deform in radial direction in respect of the centerline of the ductility element and the fluctuation of the deformable wall are illustrated by dotted lines (60,61) in the figure 2.

The ductility element is prefabricated and may be cast directly into a structural member, such as a concrete structure, or applied to the structural member afterwards. Furthermore, the reinforcement system may be used inside a concrete structure as well as on the outside of the structure, and as the tendons and ductility
5 element may be made of non-corrosive material, thus it is suitable for being used in more aggressive environments.

Figure 3 is a schematic view of a ductility element as illustrated in figure 2. Figure 3 additionally illustrates a cross sectional view of the ductility element in a line indicated by B, and an end view showing the ductility element (10) having a
10 circular cross section and a centrally circular through going channel (13), which extends coaxially within the ductility element.

A T-shaped structure (30) illustrated in a perspective view is shown in figure 4, comprising visibly three reinforcement systems, two anchorage system internal positioned in the center of the T-shaped structure covered by caps (32) and one
15 anchorage system mounted externally in a sub structure (31). The reinforcement system in the sub structure (31) extends from the sub structure and outside both structures (30,31).

The same structure (30) is illustrated in figure 5 as a side view.

Figure 5 illustrates the two reinforcement system comprising a ductility element
20 (10) internal positioned at one extremity of the T-shaped structure. The additional structure (31) comprises a ductility element (10) coupled to the tendons inside the sub structure, and having the tendon extends through the sub structure and outside both structures. The three reinforcement systems are covered by a cap (32).

25 Another embodiment of the ductility element (110) is illustrated in figure 6.

The ductility element (110) comprises a first end (111), a second end (112), four deformable walls (114,116,118,120) and a through going channel (113) adapted for receiving a tendon, the through going channel extends centrally internal through
30 the ductility element, from the first end (111) to the second end (112).

The through going channel (113) is adapted for flat tendons having a rectangular cross section.

5 The four deformable walls (114,116,118,120) are divided into sequential zones by the partitions (115,117,119), defining four compression zones.

The lead through of a tendon in the thought going channel (113) disposed within the one or more deformable zone, the through channel being disposed such that the tensile force on the tendon during use are oriented along the through going channel (113) within the ductility element (110).

10

The four deformable walls (114,116,118,120) by having varying thickness are weakened and therefore able to deform, when the ductility element being loaded.

15 The weakened deformation zones are deformable so that the length of the ductility element is increased or decreased in an axial direction along the length of a tendon.

20 In figure 6 the deformation of the weakened deformable walls are illustrated by dotted lines. During increasing pressure the ductility element will, when threshold for elastic deformation is reached, start to deform followed by a deformation resulting in a collapse.

25 The ductility element (110) has a ductile phase in axial load less than the tensile strength of the tendons, thus making the ductility element the weakest link in the reinforcement system, and the ductility element (110) will reach its strength before the other components of the reinforcement system.

The ductility element will deform when the stress excides the threshold of the ductility element, and it thus provides ductility to the reinforcement system. Thus ductility is achieved by applying a ductility element to the reinforcement system.

30 The embodiment of the ductility element (110) shown in figure 6 is shown as a side view and a top view in figure 7.

In figure 7 the ductility element (110) comprises a first end (111), a second end (112), four deformable walls (114,116,118,120) and a through going channel (113)

adapted for receiving a tendon, the through going channel extends centrally internal through said ductility element, from said first end (111) to the second end (112). The four deformable walls (114,116,118,120) are divided into sequential zones by the partitions (115,117,119), defining four compression zones.

- 5 The second end (112) may be configured to cooperate with an anchor for fixing the tendon to provide a structural connection between the ductility element and the tendon.

The above mentioned embodiment of the ductility element (110) is incorporated in a reinforcement system in a structure (130) having a T-shaped cross section
10 illustrated in figure 8 and 9.

The ductility element (110) is positioned inside the T-shaped structure (130) just below the surface of the structure and is secured by a cover part (132). A flat tendon (140) leads through the structure and extend beyond the extremity of the structure (130).

- 15 Figure 9 illustrates a bottom view of the T-shaped structure, and a cross sectional view of the T-shaped structure in the line indicated by H, the sub section indicated by J is illustrated in figure 10 in an enlarged view.

The enlarged side view of the reinforcement system, shown in figure 10, comprises a ductility element (110) and a tendon (140), which is fixed by an anchor (150) at
20 one extremity of the ductility element (110).

Figure 11 illustrates three embodiments of the weakened deformable zones of a ductility element (30).

- 25 The weakened deformation zones may be provided by slits (14a), holes (14b), such as voids or bubbles, varying thickness of the deformable walls, and/or by use of a material providing a deformable zone. The deformation walls (14c) may be adapted to deform along the periphery of the ductility element in tangential direction.

The weakened deformation zones are weakened in relation to the other parts of the ductility element. The weakened deformation zones may also be provided by suitable choice of material.

5 The ductility element may be made of metal such as steel or aluminum, cementitious material, plastics, or elastic material such as rubber, composite material or combination thereof.

Claims

1. A reinforcement system for anchoring tendons for structural reinforcing a structure such as a concrete structure, said reinforcement system comprises at least one anchor and at least one tendon, said anchor is adapted to fix said tendon in and/or outside said structure **characterized in that**, said reinforcement system comprises a ductility element, which is positioned in structural connection between said tendon and said anchor, said ductility element comprising weakened deformation zones, said weakened deformation zones are configured for increasing the ductility of said reinforcement system, said weakened deformation zones being deformable and thereby said weakened deformation zones are configured for allowing the length of deformation zones on the ductility element to increase or decrease in an axial direction along the length of said tendon, when the stress on the ductility element exceeds a certain level.
2. A reinforcement system according to claim 1, wherein said ductility element comprises multiple deformable zones positioned subsequent in an axial direction along the length of said tendon, thus providing subsequent deformable zones, enabling a sequence of ductility.
3. A reinforcement system according to any one or more of the preceding claims, wherein the ductility element comprises a through going channel, said through going channel being disposed internally within the one or more deformable zones for receiving said tendon, the through going channel being disposed such that the tensile force on the tendon during use are oriented along the extension of the through going channel.
4. A reinforcement system according to any one or more of the preceding claims, wherein the reinforcement system is configured such that the force required for deformation of the ductility element in axial load is less than the force required for deformation of the tendon.
5. A reinforcement system according to any one or more of the preceding claims, wherein said ductility element is configured such that the force required for

deformation of the ductility element in axial load being about 30-95 %, preferably 70-95 % of the force required for deformation of said tendon.

5 6. A reinforcement system according to any one or more of the preceding claims, wherein the ductility element is an integrated part of said anchor.

10 7. A reinforcement system according to any one or more of the preceding claims, wherein said ductility element comprises a circular cross section and said anchor comprises a barrel having a tapered interior bore and a compressible wedge adapted to be disposed in said barrel.

8. A reinforcement system according to any claim 7, wherein said ductility element is positioned at one extremity of said anchor as an extension of the barrel.

15 9. Anchoring system according to any one or more of the claims 1-6, wherein said ductility element (110) comprises a rectangular cross section and said internal channel comprises a rectangular cross section for the lead through of a tendon having a corresponding rectangular cross section.

20 10. Method of reinforcing a structure with a tendon, comprising fixing the tendon to the structure at different positions, and where the tendon is fixed to the structure by using ductility elements at each position, and where each ductility element is weakened at local deformation zones, and thereby deforms when the stress on the ductility element exceeds a certain level so that the length of the deformation zone
25 on the ductility element is increased or decreased in an axial direction along the length of said tendons.

Fig. 1

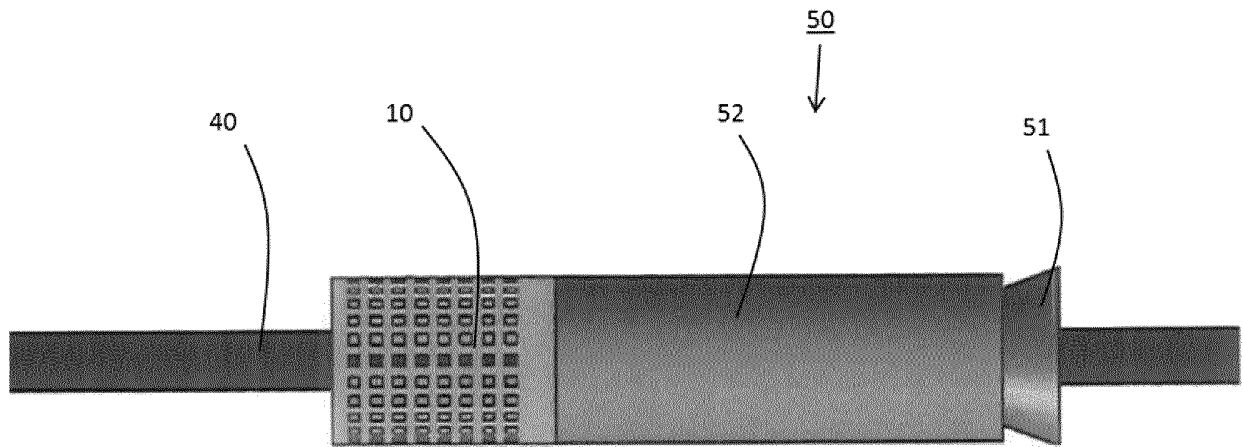

Fig. 2

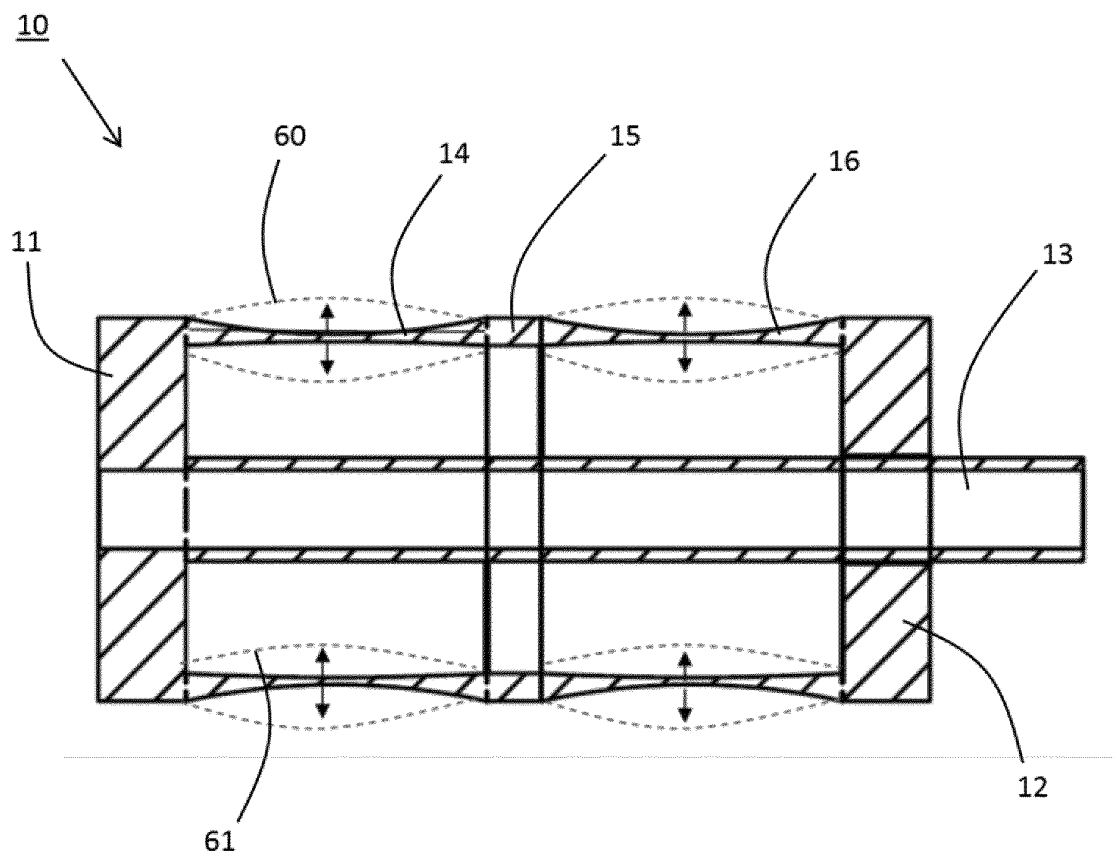

Fig. 3

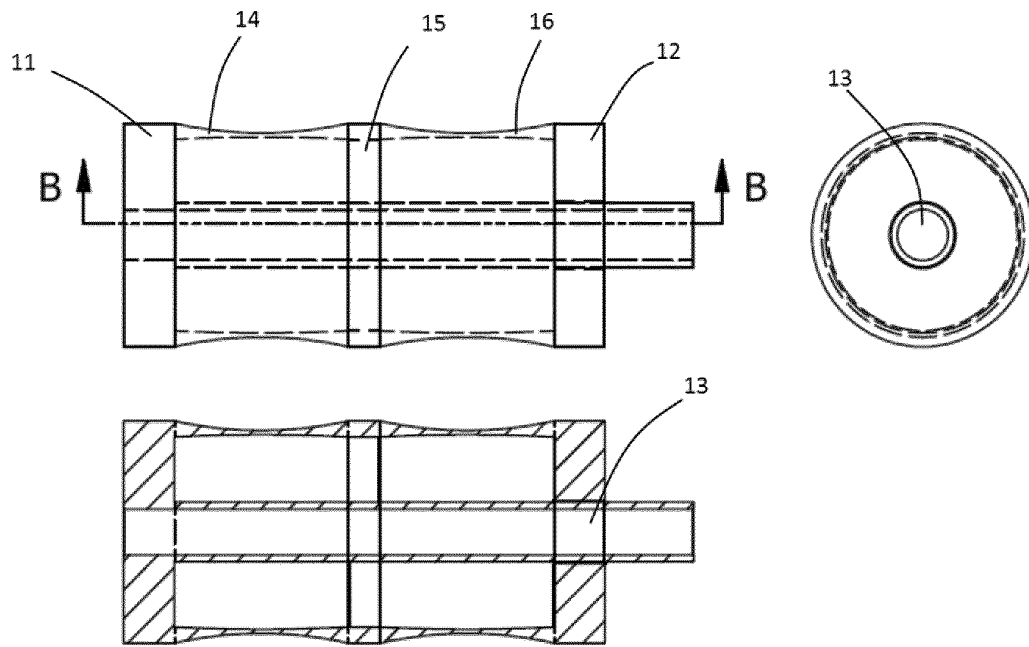

Fig. 4

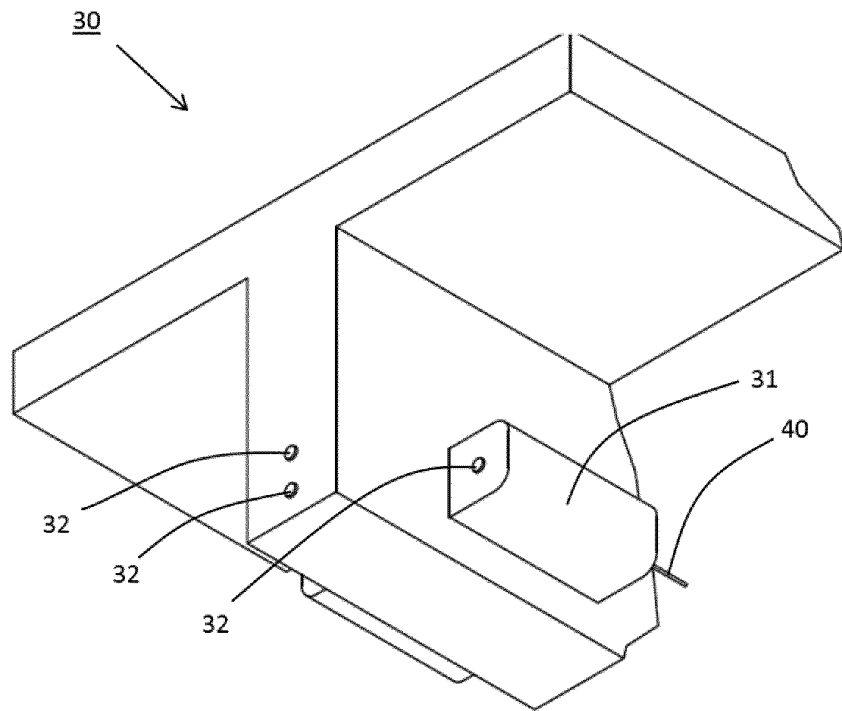

Fig. 5

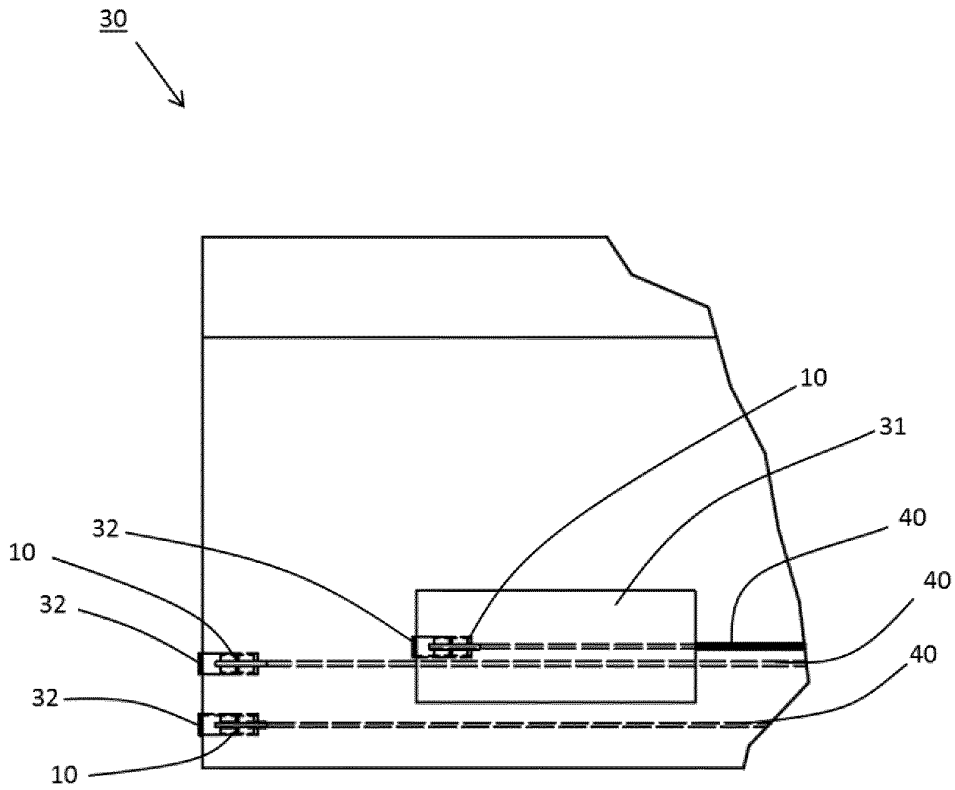

Fig. 6

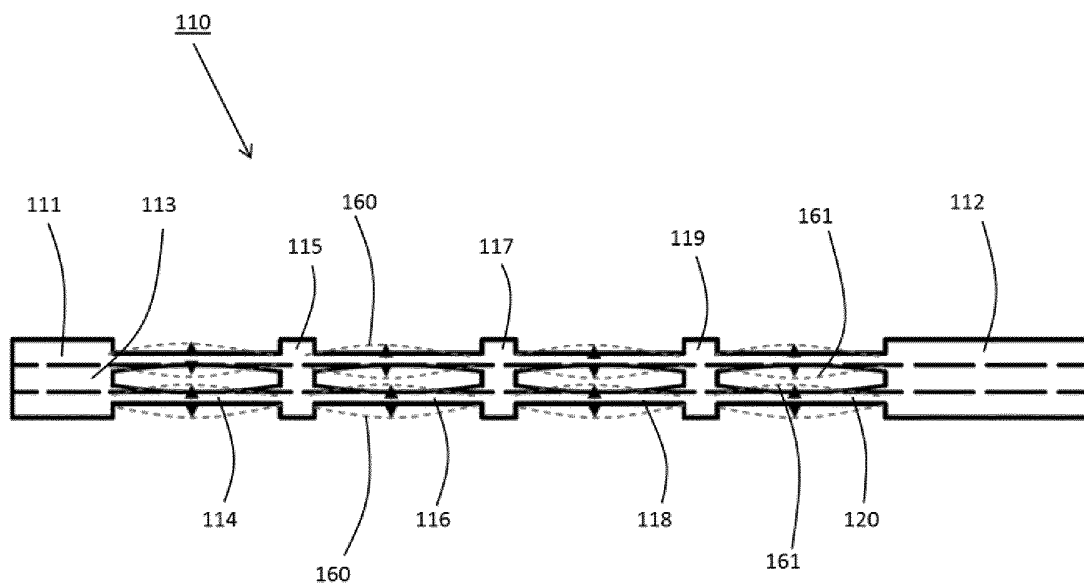

Fig. 7

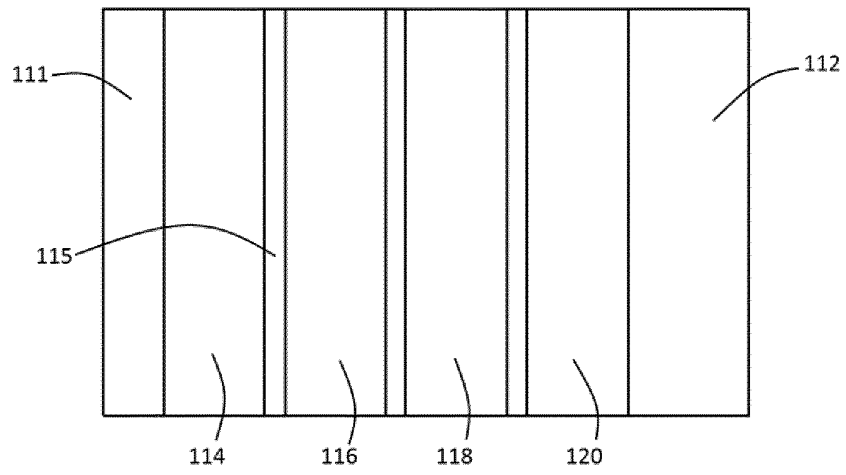
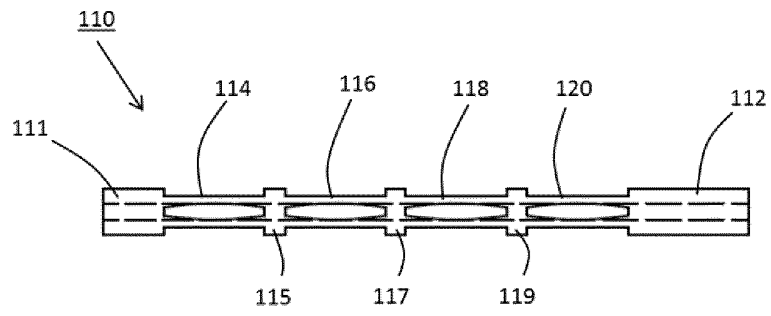

Fig. 8

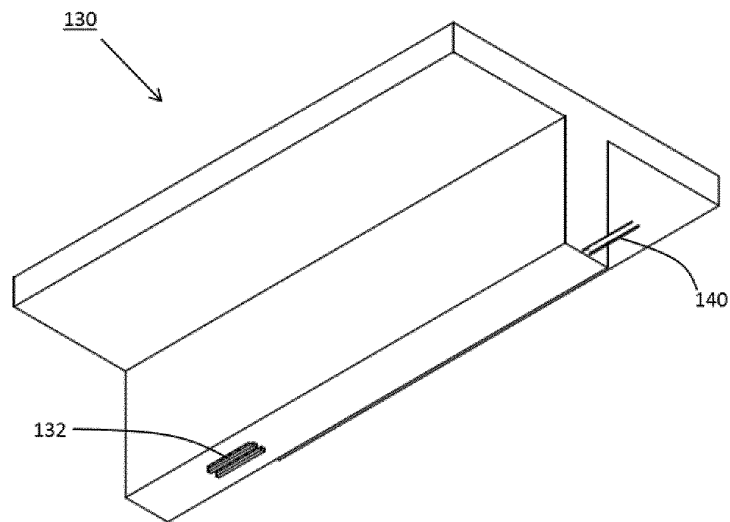

Fig. 9

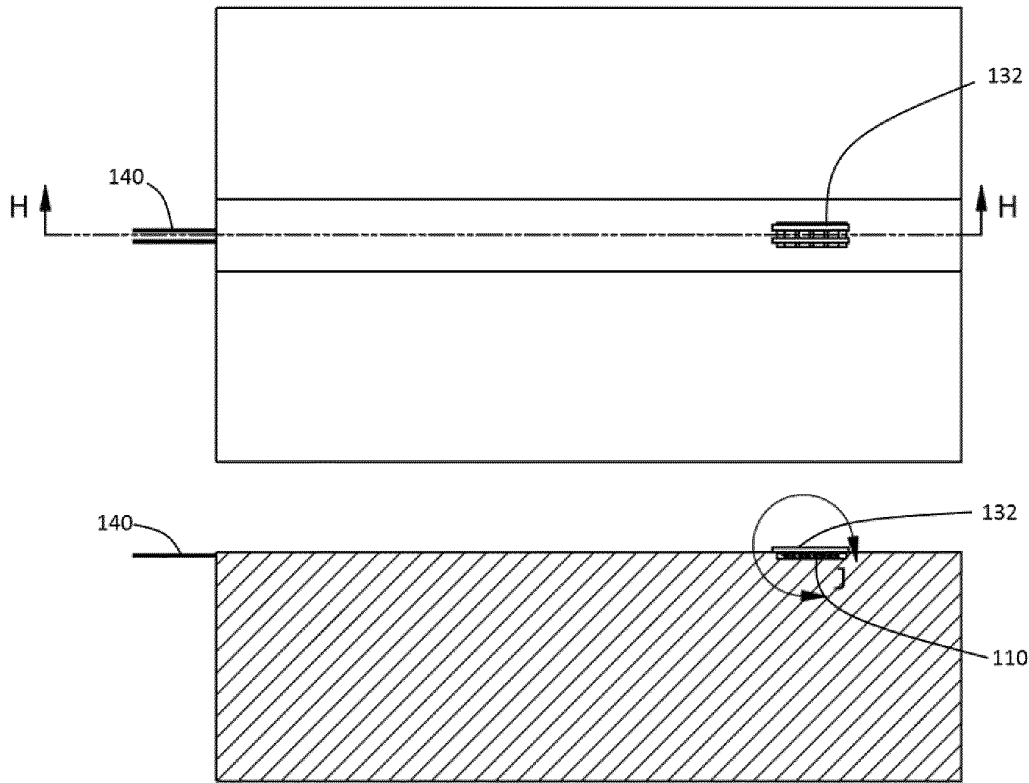

Fig. 10

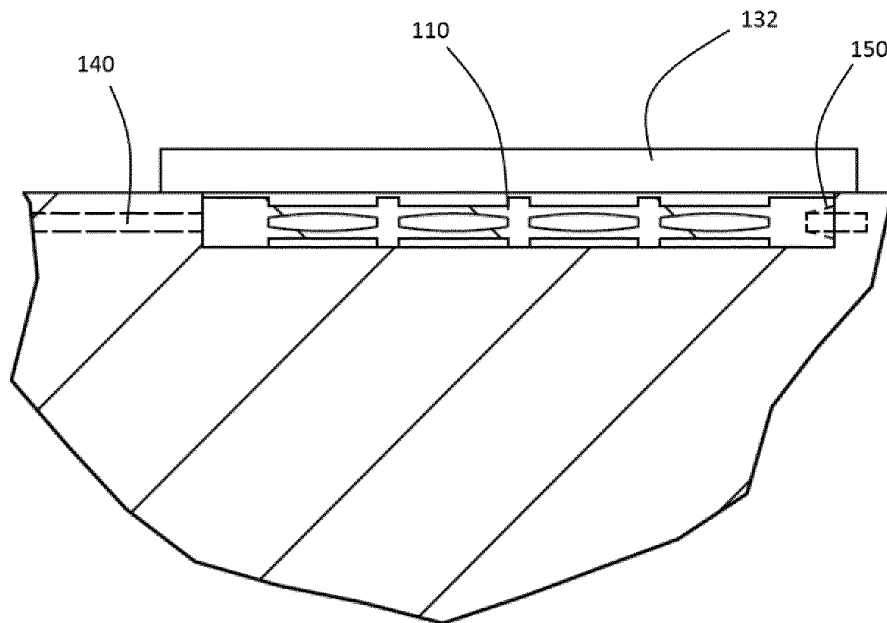

Fig. 11

