

Technical University of Denmark



Connection of OWPPs to HVDC networks using VSCs and Diode Rectifiers: an Overview

Saborío-Romano, Oscar; Bidadfar, Ali; Göksu, Ömer; Altin, Müfit; Cutululis, Nicolaos Antonio; Sørensen, Poul Ejnar

Publication date:
2016

Document Version
Peer reviewed version

[Link back to DTU Orbit](#)

Citation (APA):

Saborío-Romano, O., Bidadfar, A., Göksu, Ö., Altin, M., Cutululis, N. A., & Sørensen, P. E. (2016). Connection of OWPPs to HVDC networks using VSCs and Diode Rectifiers: an Overview. Poster session presented at 15th International Workshop on Large-Scale Integration of Wind Power into Power Systems as well as on Transmission Networks for Offshore Wind Power Plants, Vienna, Austria.

DTU Library

Technical Information Center of Denmark

General rights

Copyright and moral rights for the publications made accessible in the public portal are retained by the authors and/or other copyright owners and it is a condition of accessing publications that users recognise and abide by the legal requirements associated with these rights.

- Users may download and print one copy of any publication from the public portal for the purpose of private study or research.
- You may not further distribute the material or use it for any profit-making activity or commercial gain
- You may freely distribute the URL identifying the publication in the public portal

If you believe that this document breaches copyright please contact us providing details, and we will remove access to the work immediately and investigate your claim.

Oscar Saborío-Romano, Ali Bidadfar, Ömer Göksu, Müfit Altin, Nicolaos A. Cutululis, Poul E. Sørensen

Background, Challenges, Objectives

- Control strategies exploiting type-4 WT converters have been shown to enable the use of DRs for connecting OWPPs to HVDC
- Compared to VSCs, DRs offer advantages such as:
 - Reduced offshore converter station size
 - Reduced losses
 - Reduced investment installation and maintenance costs
 - Increased reliability
- The corresponding control functions have to be delegated to the WT front-end VSCs
- Fundamentally different WT and WPP control schemes are required
- The control philosophy changes from grid-following units to grid-forming units
- The aim is to present an overview of the requirements for connecting OWPPs using HVDC technology
- What are their implications when using VSCs and DRs?

Two Offshore Power Converter Technologies

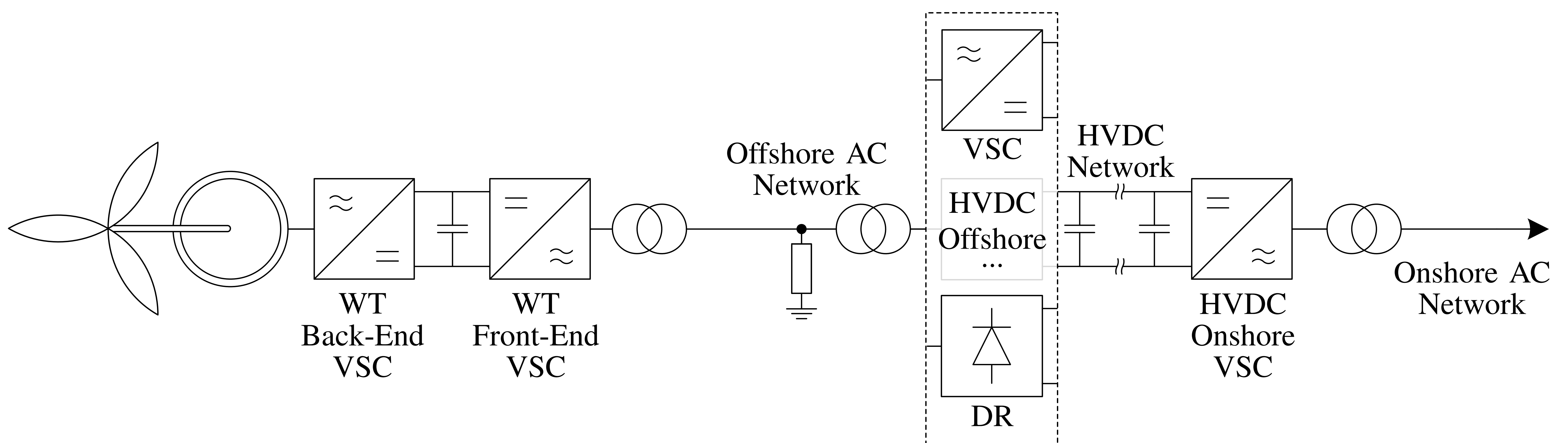

- VSCs are assumed to be used as the HVDC onshore converters
- VSCs or DRs are used to refer directly to the technology choice for the HVDC offshore converters
- Thyristor-based LCCs are not considered

Requirements imposed by Onshore AC Networks

- Services to be provided to them via the HVDC networks
- Frequency support
- Active power control
- Power oscillation damping
- AC voltage support
- Fault ride-through

Requirements imposed by DC and Offshore AC Networks

- Support services to help maintaining their stability
- DC-connected power park requirements in ENTSO-E's HVDC Code have been built upon ENTSO-E's RfG Code
- Operational voltage and frequency ranges
- Fault ride-through
- Offshore AC voltage generation

Discussion

- Current requirements are mainly based on those for onshore generation
- They can be more stringent than necessary
- This can hinder the exploitation of some technologies and corresponding cost reductions
- Current requirement paradigm: HVDC offshore terminals are grid-forming units, OWPPs are grid-following units
- This is not compatible with cost-reducing solutions such as DRs, which require the OWPPs to become the grid-forming units
- More in-depth studies are necessary before requirements specific for DR-connected OWPPs can be established