

Technical University of Denmark



## Hardware-in-the-loop Test for Demand as Frequency Controlled Reserve

Liu, Zijian; Zimmermann, Jakob Kjær; Wu, Qiuwei

*Publication date:*  
2014

*Document Version*  
Publisher's PDF, also known as Version of record

[Link back to DTU Orbit](#)

*Citation (APA):*

Liu, Z., Zimmermann, J. K., & Wu, Q. (2014). Hardware-in-the-loop Test for Demand as Frequency Controlled Reserve. Technical University of Denmark, Department of Electrical Engineering.

### DTU Library Technical Information Center of Denmark

---

#### General rights

Copyright and moral rights for the publications made accessible in the public portal are retained by the authors and/or other copyright owners and it is a condition of accessing publications that users recognise and abide by the legal requirements associated with these rights.

- Users may download and print one copy of any publication from the public portal for the purpose of private study or research.
- You may not further distribute the material or use it for any profit-making activity or commercial gain
- You may freely distribute the URL identifying the publication in the public portal

If you believe that this document breaches copyright please contact us providing details, and we will remove access to the work immediately and investigate your claim.

# Hardware-in-the-loop Test for Demand as Frequency Controlled Reserve

Zijian Liu, Jakob K. Zimmermann and Qiuwei Wu

December 2014

## **Hardware-in-the-loop Test for Demand as Frequency Controlled Reserve**

2014

By

Zijian Liu, Jakob K. Zimmermann and Qiuwei Wu

Copyright:      Reproduction of this publication in whole or in part must include the customary bibliographic citation, including author attribution, report title, etc.

Funded by:      Energinet.dk as a part of the framework agreement relating to the use of PowerLabDK's facilities.

Published by:    Department of Electrical Engineering, Elektrovej, Building 325, DK-2800 Kgs. Lyngby, Denmark

Request report [www.elektro.dtu.dk](http://www.elektro.dtu.dk)  
from:

1.	Introduction .....	5
1.1	Background.....	5
1.2	Literature review .....	5
1.3	Bornholm power system.....	5
1.4	Hardware in the loop test.....	7
2.	Models and Interface .....	8
2.1	Bornholm system model.....	8
2.2	RSCAD Heat Pump Model.....	9
2.2.1	Control.....	9
2.2.2	Configuration.....	10
2.2.3	Initialisation.....	12
2.2.4	Test.....	12
2.3	HIL interface.....	14
3.	DFR Control Logics .....	17
3.1	Introduction .....	17
3.2	Control objective .....	17
3.3	Control logics.....	18
3.3.1	Control logic type I .....	18
3.3.2	Control logic type II .....	18
3.4	Simulation designing .....	19
3.4.1	Type I control logic application .....	19
3.4.2	Type II control logic application .....	21
4.	Simulation Scenarios .....	23
4.1	Basic Scenarios .....	23
4.2	Simulation settings .....	25
5.	Results and Discussion.....	26
5.1	Results demonstration .....	26
5.2	Frequency regulation efficacy .....	28
5.3	Specific discussions .....	33

5.3.1	Introduction .....	33
5.3.2	Hardware-in-the-loop test performance .....	33
5.3.3	Heat pump DFR responding to slight disturbance.....	34
5.3.4	High penetration level oscillation.....	36
5.3.5	FCR requirements discussion .....	36
6.	Conclusion.....	38
7.	Bibliography .....	39

# 1. Introduction

## 1.1 Background

The alternating current (AC) technology dominates the electric power transmission field today due to diverse reasons. Frequency, AC's significant parameter, affects every aspect of power system. A stable system frequency demonstrates the balance between power generation and demand. Frequency-sensitive loads such as motors and electronic devices function properly in nominal frequency range. Therefore, system frequency stability is the key issue in power system operation.

Power generation and demand can contribute equivalently to frequency control as reserves in theory. However, the complex situation of demand side brings overlook on its potential. The real-time monitoring requirement for many distributed, small sized loads, is considered the major obstacle to utilize the demand as reserves [1]. Besides, for most end user appliances, external control actions could undermine customer comfort meanwhile bring extra wear and tear. Therefore power plants undertake frequency reserve service conventionally. Demand side method such as load shedding is only considered as emergency measures if the frequency drops below 49Hz.

However, in the wake of renewable energy development, the conventional mode is facing growing challenge now. Danish power system is an appropriate case. The wind energy penetration has a rapid growth and aims to achieve 50% in 2025. Thus the lack of balancing resources becomes an inevitable issue. The researching of demand frequency reserve (DFR) is boosted. In fact, some household electricity appliances are suitable for reserve requirements. Furthermore, they could have considerable capacities due to the large number of units, for example, refrigerators, freezers and electric heating loads. By installing sensors and controllers with proper control logic, those appliances can respond autonomously to frequency deviation and provide fast reserve to the system. Among them, electric heating loads are particularly attractive because their heat capacity allows electric power consumption to be moved in time without degrading the quality of service. In this project, the efficacy of the frequency regulation provided by the electric heating loads will be focused.

## 1.2 Literature review

Practice on using demand as frequency reserve has never stopped in last 20 years. 1000MW Industrial loads in Finland are used as manual reserves [3]. In [4], industrial loads controlled by low frequency relay are involved in a market – based demand management program. These projects verified the feasibility of DFR, but mainly focused on industrial loads. In [5], the Pacific Northwest National Laboratory (PNNL) put forward the point that household appliances could be disconnected within seconds temporarily as reserve. Technical University of Denmark (DTU) contributes in this branch. Implementation and practical demonstration on DFR is carried out with SmartBox and refrigerator as described in [6]. In [1], two types of DFR control logic are tested with Bornholm system model in DigSILENT Power Factory.

## 1.3 Bornholm power system

Bornholm is a Danish island located in the Baltic Sea. It is equivalent to about 1% of Denmark with regard to area, population and energy consumption.

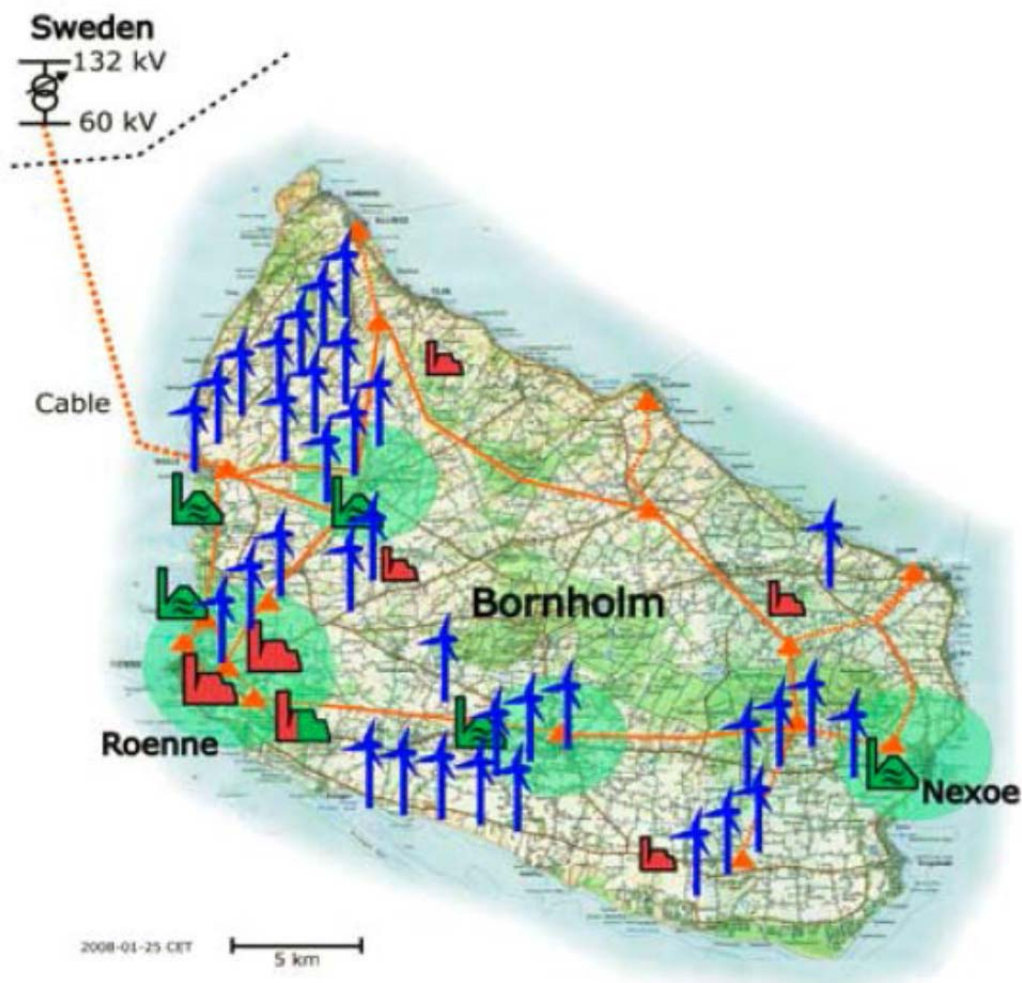

Figure 1 – The island of Bornholm with major generation units and 60 kV grid [7]

Bornholm power system is regarded representative for Danish distribution grid with substantial wind power. The yearly wind power penetration is about 33%. The Bornholm power system is connected to Swedish power system, but can also run in island operation mode.

Table 1 – Major technical information of Bornholm power system

Property	Type	Value
Substation	Number of 60/10 kV	16
	Number of 10/0.4 kV	1006
Generation Units	Wind power plants	30MW
	CHP/biomass and coal	16MW
	Biogas PLANT	2MW

	Others	1MW
Demand	Peak load	55MW

It is a commonly known that electricity generated from wind power could be highly variable. When Bornholm system runs in island operation mode, it will be difficult to maintain the frequency stability with large wind power capacities online. It is a quite typical issue for distributed systems with high wind power penetration, especially the expected Danish power system in 2025. Therefore, Bornholm power system, island operation mode in particular, is considered to a miniature of future Danish power system. It ideally suits for researching of DFR technology.

#### 1.4 Hardware in the loop test

Hardware in the loop (HIL) test is the key simulation method in this project. Different from pure virtual simulation, HIL is a technique in which hardware equipment is incorporated into the simulation, especially simulation of large size system. A real-time simulator runs a system model meanwhile communicates and interacts with hardware through an interface. Such an approach provides many unique advantages:

- HIL test makes it possible that an apparatus can be investigated repeatedly and thoroughly in a realistic emulated environment even long before the actual system has been built and commissioned.
- Some extreme conditions can be examined without the risk of unacceptable loss. The limit or defects of apparatus could be discovered with the greatest chance.
- Transients generated by hardware can be transmitted to system model. It helps improve the system designing with accurate references [8].

HIL test has been applied to power system simulation in recent years. It is mainly used in testing and regulating stability issues of large scaling power system. A real-time platform which can model large scaling power system is essential. In this project, Real Time Digital Simulator (RTDS) developed by RTDS Technologies Inc. plays the role as such a platform.



## 2. Models and Interface

### 2.1 Bornholm system model

A preliminary Bornholm power system model is built in RTDS. In order to simplify the simulation complexity, only dispatchable generation units, specifically CHP plant and biogas plant, are remained in the model. All wind turbines and other undispachable generation units are removed due to being helpless on frequency regulation. Corresponding value of loads are reduced from the system to make sure the stability of power flow. Thus the nominal generator capacity and total demand in the system are equally 18MW.

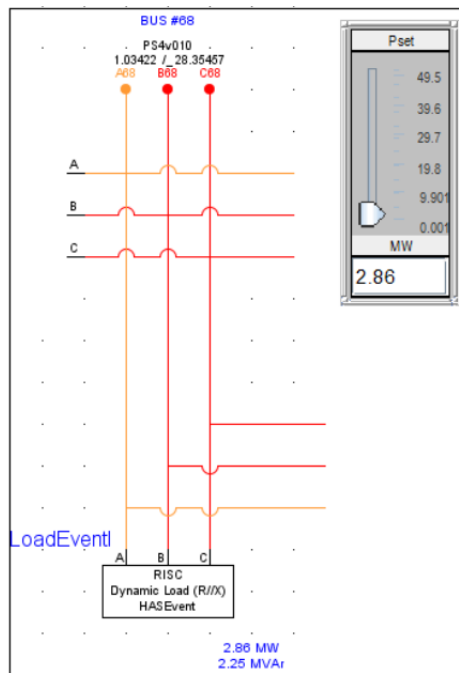

Figure 2 – Load event block in RTDS

Figure 2 shows the RISC dynamic load model located in Hasle. The load value is accurately controlled by a slider in Runtime interface. By changing it, load variation contingency can be simulated. As mentioned above, wind turbines and other undispachable generation units are eliminated in Bornholm RTDS model while only synchronous generation block 5 and 6 remained. Thus it is impossible to simulate scenarios which resulting in generation outage, for instance, winddrop below the rated speed of wind turbine. In spite of this, the load variation can break the power balance, i.e. lead to system frequency instability equivalently. Since this project focusing on the efficacy of heat pump as frequency reserve, the cause of contingency is less concerned.

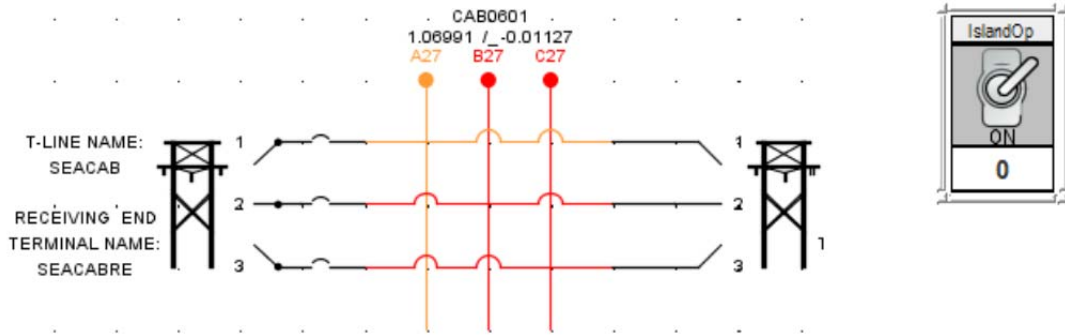

Figure 3 – Sea cable model in RTDS

The sea cable model can be connected/disconnected grid by a trigger. When it is disconnected, the Bornholm system runs in island operation.

## 2.2 RSCAD Heat Pump Model

A house with a heat pump is created as a component in RSCAD. The model is based on formula (4.1a-b) in EcoGrid EU D1.4a\_2 shown below to calculate the change in temperature of the inside and structure at each simulation step.

$$\dot{T}_i = \frac{1}{C_i} (U_{ie}(T_e - T_i) + U_{ia}(T_a - T_i) + Q_H + A_w \Phi_s) \quad (1)$$

$$\dot{T}_e = \frac{1}{C_e} (U_{ea}(T_a - T_e) + U_{is}(T_i - T_e) + A_e \Phi_s) \quad (2)$$

The heat pump draws power from a three phase bus and is implemented as a pure resistive load in a delta configuration. The conductivity of each resistive load is calculated using the rated bus voltage (3). The heating power is calculated from the actual bus line to line voltages and the heat pump COP. A large difference from the rated voltage will result in a different output power.

$$G = \frac{P/3}{V_{rated}^2} \quad (3)$$

$$Q_H = COP \cdot P \quad (4)$$

$$P = G(V_{ab}^2 + V_{bc}^2 + V_{ca}^2) \quad (5)$$

$$COP = COP_A(T_i - T_a) + COP_B \quad (6)$$

### 2.2.1 Control

There are implemented two control types. The inputs for the model are different in the two cases as shown in Figure 4. If the control is in On/Off mode, the heat pump will heat at 0 or 100 % using a hysteresis between TsetMin and TsetMax.

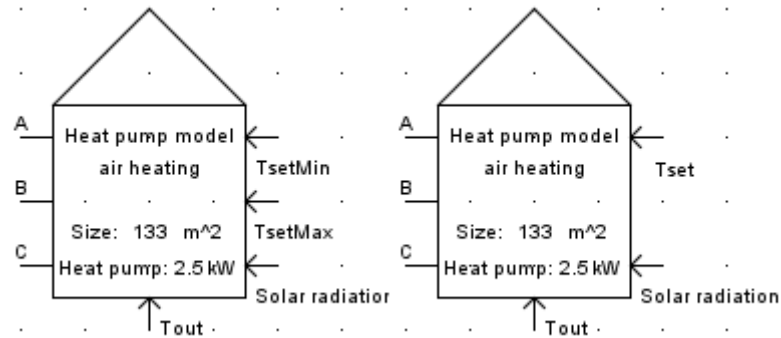

Figure 4 – RSCAD Heat Pump Model with relay control (left) and inverter control (right)

With an inverter, the output can be adjusted between 0 and 100%. To make the controller simple a proportional controller is used. To avoid the steady state error inherent in a proportional controller the energy loss from the inside is used in addition to the actual and set point temperature. This is done by taking formula 1.1a substituting  $Q_H = COP \cdot P$  and  $\dot{T}_i = T_{set} - T_i$  and then isolating  $P$ .  $P$  is then limited to the range of the heat pump.

$$P = \frac{-U_{ie}(T_e - T_i) - U_{ia}(T_a - T_i) - A_w \Phi_s + (T_{set} - T_i)C_i}{COP} \quad (7)$$

### 2.2.2 Configuration

The inputs to the model are always the outside temperature [ $^{\circ}C$ ] and solar radiation [ $W/m^2$ ]. The set point temperature is a single value with inverter control but in relay control it has a minimum and maximum value.

The configuration is split into three tabs. The first tab (Figure 5) has the required parameters and the values used for initialization of the model. It is also possible to set a higher scale factor, so the simulation is of X identical houses instead of just one.

house.def					
CONFIGURATION		House	Monitoring		
Name	Description	Value	Unit	Min	Max
prtyp	Solve Model on card type:	GPC/PB5		1	2
Name	Component name	HeatPump1			
AorM	Assignment of Model to Processor Card	Automat...		0	1
CARD	-if Manual: Begin on Card	1	1 to 6	1	6
Rprc	-if Manual: Begin on Processor	A		0	1
Aprc	-if Auto: Begin on Processor	Either		0	2
Scale	Scale to x houses, all monitored values are of one house	1		1	
Vbus	Rated Line to Line Bus Voltage	.6	kV(RMS)		
Tairnit	Initial inside temperature	20.5	deg C		
Toutnit	Initial outside temperature	5	deg C		
Q_Sinit	Initial solar radiation	30	W/m^2	0	

Figure 5 – Configuration parameters, general

In the second tab the parameters of the house and the heat pump can be adjusted. Underfloor heating is not implemented yet, but will also be configurable from here. COP is calculated using formula (6) based on the two values given here.

The last tab is to enable monitoring of different parameters in the model and giving the parameters name. It is possible to monitor power, COP and all the simulated temperatures and heat flows.

house.def					
CONFIGURATION		House	Monitoring		
Name	Description	Value	Unit	Min	Max
Area	Ground area	133	m^2	1	
Height	Height of house	2.5	m	1	
Power	Maximum heat pump power draw	2.5	kW	1	
V	Ventilation rate	0.5		0	
COPA	COP scaling factor (ax+b) where x is difference in temperature	-0.03528		-1	0
COPB	COP factor with no temperature difference	3.807		1	100
Awindow	Part of wall with window	.2		0	1
control	Chose between relay (ON/OFF) and inverter control	Relav		0	1
uffHeat	Underfloor or air heating	Air		0	1

Figure 6 – Configuration parameters, house

### 2.2.3 Initialisation

For the initialisation of the model the values outside of the model is not available. Therefore initialisation values must be given, as shown in Figure 5. The interior temperature is set directly. The exterior temperature is then calculated from (2) using  $\dot{T}_e = 0$ .

$$T_e = \frac{U_{ea}T_a + U_{is}T_i + A_e\Phi_s}{U_{ea} + U_{is}} \quad (8)$$

### 2.2.4 Test

To test the model a simple test case is created, shown in Figure 7. A breaker is placed between the source and the model controlled by the switch Pump2. The outside temperature is controlled by a slider.

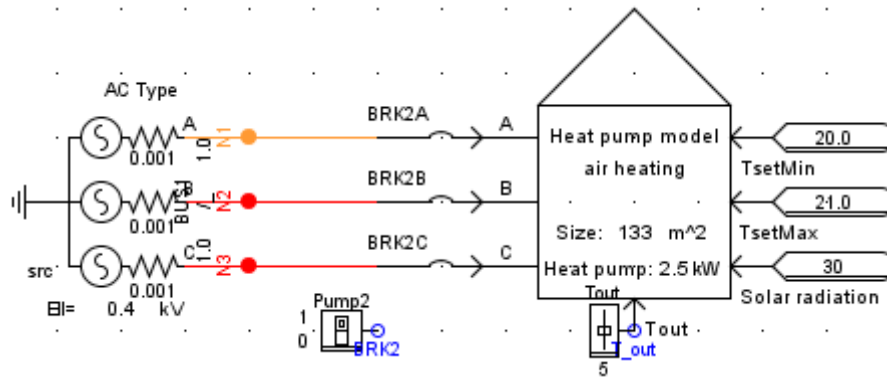
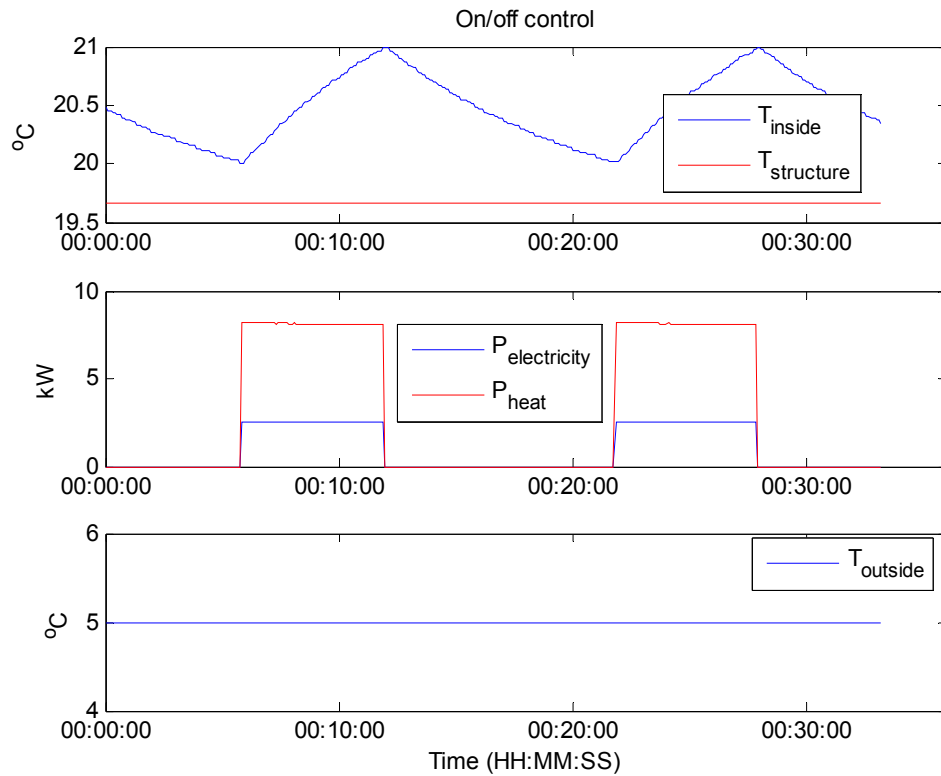

Figure 7 – Heat pump model test case

Running the model with the default parameters gives the result shown in Figure 8. The solar radiation was set to 30 W/m<sup>2</sup> and the temperature range to 20-21 °C.



**Figure 8 – On/off control with default parameters**

Changing the control type to inverter based and the set point to 20.5 °C gives the results shown in Figure 9. At around 13 minutes a breaker between the source and the model was switched off for a short period. The inside temperature drops in this period and as soon power is restored the heat pump restarts at full power until the temperature is restored to the set point. In the end the outside temperature is changed but the controller immediately changes the heat pump output so the temperature is kept constant. If a temperature change is kept for a longer period the structure temperature will slowly change.

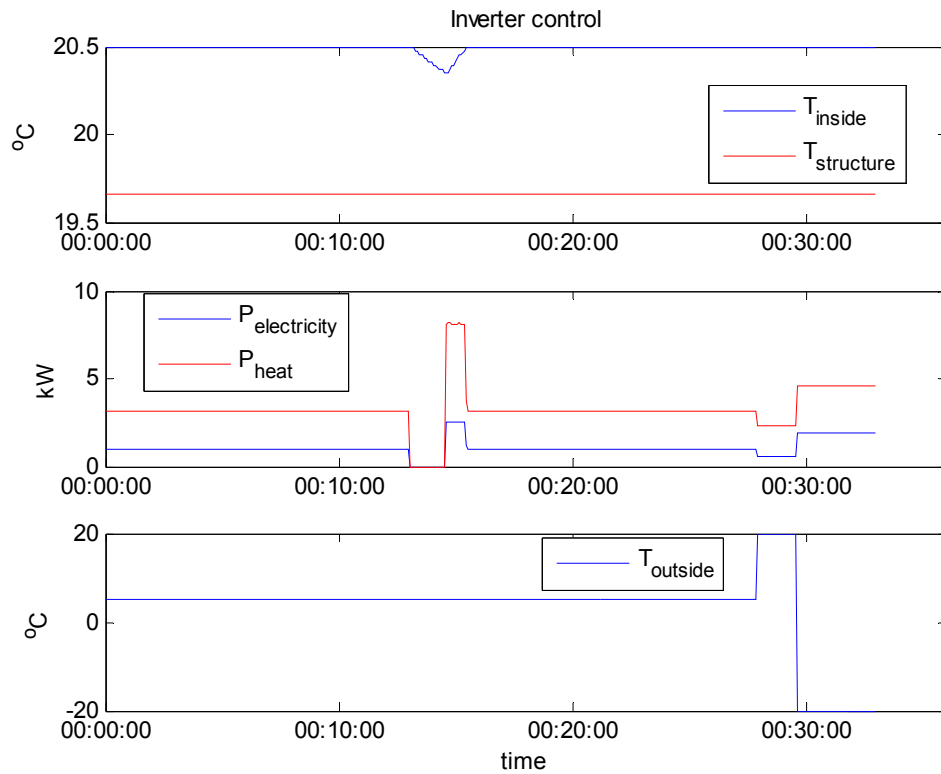

Figure 9 – Inverter control reaction on manual changes

There have not been run exhaustive test on the processor load, but the stacking load is set to 5 and at that level a processor was tested at full load without experiencing a time step overflow. If it is needed it is possible that the stacking load could be reduced.

### 2.3 HIL interface

The SmartBox is a demand response (DR) device developed for use in smart grid projects with the need of being able to regulate numerous demands while measuring consumption, grid frequency and other related parameters [9].



Figure 10 – SmartBox appearance [9]

This programmable apparatus is developed as a multi-function hardware for different project in electrical engineering. The SmartBox is supplied from a standard 230 V outlet and is measuring frequency, voltage and current draw of any load attached to the SmartBox [9]. It can control or regulate an attached device according to digital or relay signals. In this project, this box controls a RTDS heat pump model as DFR by measuring the system frequency. The interface of Smart-Box and RTDS consists of a GTA0 and GTDI card.

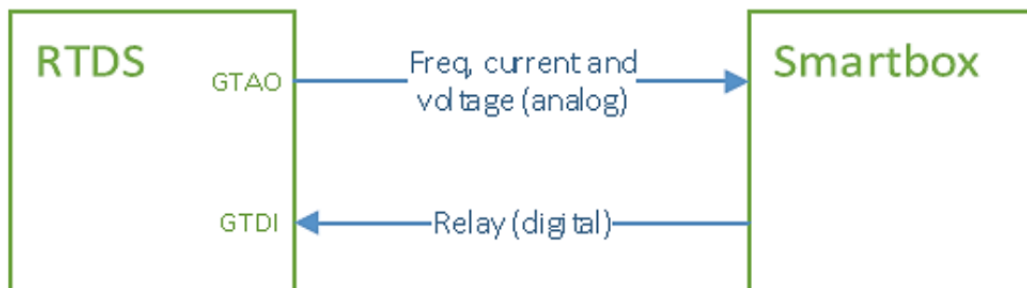

Figure 11 – Interface diagram of SmartBox

In order to illustrate the interaction between RTDS and SmartBox, a more detailed interface diagram is presented as Figure 7. The frequency at bus 88 in the system model is read at GTA0 channel 1. The GTA0 card does a D/A transformer and output the analog signal to SmartBox. The signal runs through a measurement transformer and an analog filter. Then the analog signal is processed by a 16-bit A/D converter. The system frequency is calculated by zero-crossing algorithm. A central processing unit (CPU) takes care of all data handling, time stamping and control of internal elements. In this project, the CPU sends a command to relay device according to system frequency condition. The GTDI card reads the relay status input from the Smart-Box. A word to bit converter transfers the relay status to a switching signal to the breaker model of heat pump.



One point worthy emphasizing is that the HIL test in this project is classified as controller HIL. That means the hardware is a controller dealing with low level signals (typically within a range of  $\pm 10V$ , 50mA [8]). No extra interface devices are needed since the converters are qualified for signal transmission. However, in some cases the hardware could be a power apparatus such as a transformer or motor. Then extra interface device are required to carry out signal processing task.

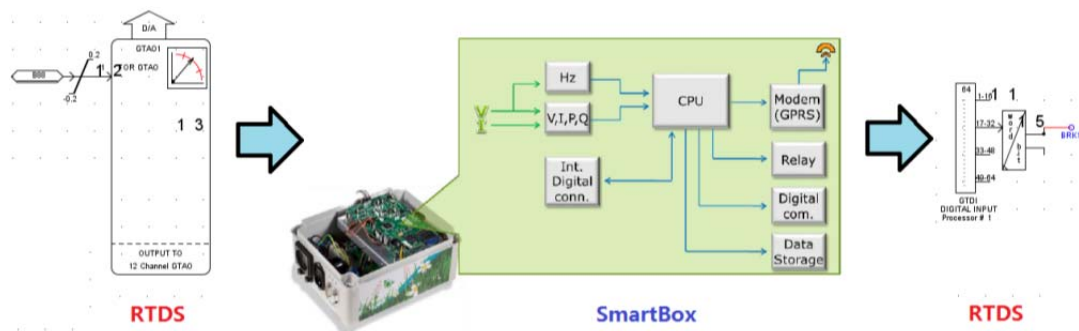

Figure 12 – Detailed diagram for HIL interface

## 3. DFR Control Logics

### 3.1 Introduction

In this chapter, the objective of DFR control is clarified firstly. The DFR control logics from [1] will be briefly introduced. The focal point is how to modify and apply the logics to RTDS model and HIL test.

### 3.2 Control objective

In this section, how the DFR control getting involved into power system load-frequency control is investigated.

The supporting document [10] is for the network code on load – frequency control and reserves. In a relative document [11], reserve providing units, both power generation module and demand units are classified into 3 kinds according to efficacy:

- Frequency Containment Reserves (FCR) means the Operational Reserves activated to contain System Frequency after the occurrence of an imbalance.
- Frequency Restoration Reserves (FRR) means the Active Power Reserves activated to restore System Frequency to the Nominal Frequency and for Synchronous Area consisting of more than one LFC Area power balance to the scheduled value.
- Replacement Reserves (RR) means the reserves used to restore/support the required level of FRR to be prepared for additional system imbalances. This category includes operating reserves with activation time from Time to Restore Frequency up to hours.

Due to the designed control logic (See section 3.3), the supposed heat pump DFR activation time is within several seconds. Therefore DFR is suitable as FCR. In addition, since heat pump should be back to normal duty circle for customer comforts, it is not ideal for relative long period secondary frequency control as FRR or RR.

The responsibility of FCR is providing primary frequency control to restrain the frequency deviation in first time. In [11], the minimum technical requirements for FCR are proposed. The requirements specifically raised for Nordic energy system are listed in table 3. These requirements are regarded as objectives of heat pump DFR control.

Table 2 – FCR minimum technical requirements for NE [11]

Minimum accuracy of measurements	Requirements for Nordic power system
Maximum combined effect of inherent Frequency Response Insensitivity and possible intentional Frequency Response Dead band of the governor of the FCR Providing Units or FCR Providing Groups.	10mHz
FCR Full Activation Time	30s if frequency is outside
FCR Full Activation Frequency Deviation.	standard frequency range

### 3.3 Control logics

#### 3.3.1 Control logic type I

The type I disconnects and reconnects electric appliances to the grid when system frequency falls and recovers, respectively [1].

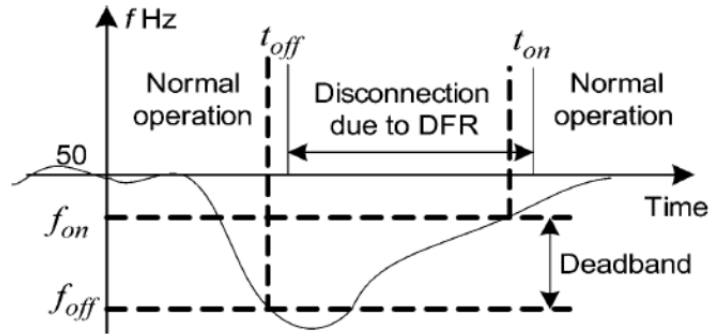

Figure 13 – Illustration of Type I control [1]

One key point in control logic type I designing is that the reconnection frequency should be equal or higher than the disconnection frequency set point. Otherwise it may lead to frequency oscillation between the two set points and further extra tear and wear of appliances. For thermostatically controlled loads, there are two possible designing about the appliances condition after reconnection. Ia is always start on and Ib is depending on the reconnection temperature. In this project, the first design is chosen.

#### 3.3.2 Control logic type II

The control logic type II is customized for switching the thermostatically controlled loads by adjusting the nominal temperature set points  $T_{high}^{normal}$  and  $T_{low}^{normal}$ . An offset coefficient  $k_f$  connects the frequency deviation with temperature offset, i.e.,

$$T_{high} = T_{high}^{normal} + k_f(f - f_0) \quad (9)$$

$$T_{low} = T_{low}^{normal} + k_f(f - f_0) \quad (10)$$

$f_0$  is the nominal frequency, 50Hz in Nordic power system. The basic thought inside this control logic is giving an offset which is proportional to frequency deviation to the thermostatically controlled loads set points in order to activate them as DFR. A figure in [2] illustrates this mechanism quite clear.

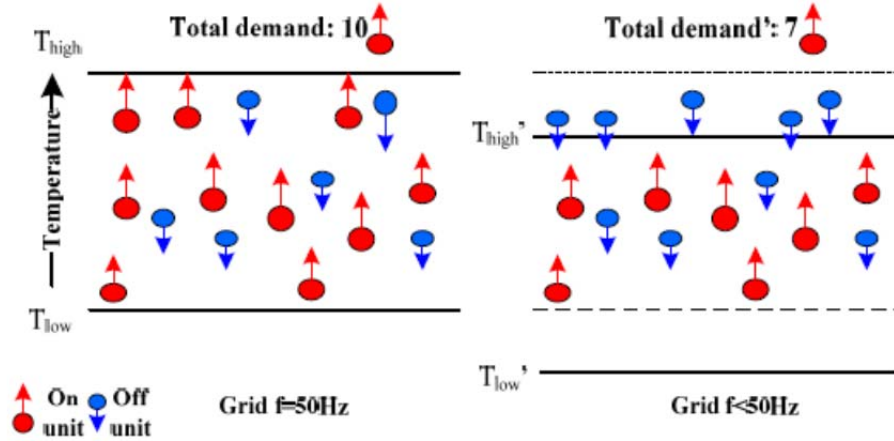

Figure 14 – Illustration of Type II control [2]

Figure 14 gives the information that when frequency drops, the offset makes the temperature set points drops with it. Then several initially on heat pump units are turned off due to outside the set point. Consider a large number of heat pumps distributed uniformly in their temperature set range. If the frequency varies by  $\Delta f$  and if  $kf\Delta f \leq T_{high}^{normal} - T_{low}^{normal}$ , the power decrease or increase can be estimated by

$$P_{off} = \frac{kf\Delta f}{T_{high}^{normal} - T_{low}^{normal}} \times P \times \lambda \quad (11)$$

$$P_{on} = \frac{kf\Delta f}{T_{high}^{normal} - T_{low}^{normal}} \times P \times (1 - \lambda) \quad (12)$$

Where  $P$  is the total installation of heat pumps and  $\lambda$  is the percentage of on units [1].

In type II control, offset coefficient  $kf$  is the key parameters. The bigger  $kf$  brings larger temperature offset and then activate more heat pumps for frequency regulation. But there is also a limitation since bigger  $kf$  also leads to greater probability of appliance tear and wear. Therefore, different  $kf$  values can be used or different frequency range. In this paper, two  $kf$  values are used in the same control system.

### 3.4 Simulation designing

#### 3.4.1 Type I control logic application

This section gives the information that how the type I logic controlled heat pumps DFR are applied to the Bornholm system model.

There are 6 heat pump models controlled with type I logic. Each heat pump model has the equal capacity. All these 6 heat pumps operate in inverter mode. Therefore they have a constant total power consumption when connected to the system. That makes this type of reserve have a quite stable capacity. Furthermore, they are supposed to be turned on after reconnection, which is the requirement of type Ia.

The disconnection set point is chosen as 49.90Hz which is the standard frequency range according to [10]. In [2], a suggestion is put forward that the set points of many DFRs with similar capacities can be designed according to a uniform distribution over a small range. It can make the reserves activated proportionally. Therefore the disconnection set points are designed separately from 49.90Hz to 49.85Hz.

**Table 3 – Disconnection set points of type I heat pump**

Heat pump model number	Disconnection frequency
1	49.90Hz
2	49.89Hz
3	49.88Hz
4	49.87Hz
5	49.86Hz
6	49.85Hz

The HIL test is applied to heat pump model 1. As shown in Figure 12, the SmartBox controls the breaker of heat pump model 1. In reality, a compressor is the key device of heat pump. It is not reasonable to turn on/off the compressor twice or more in a short time. Therefore, the SmartBox is programmed to fulfill that requirement by setting some time limits. These are summarized in table 5 with illustrator Figure 15.

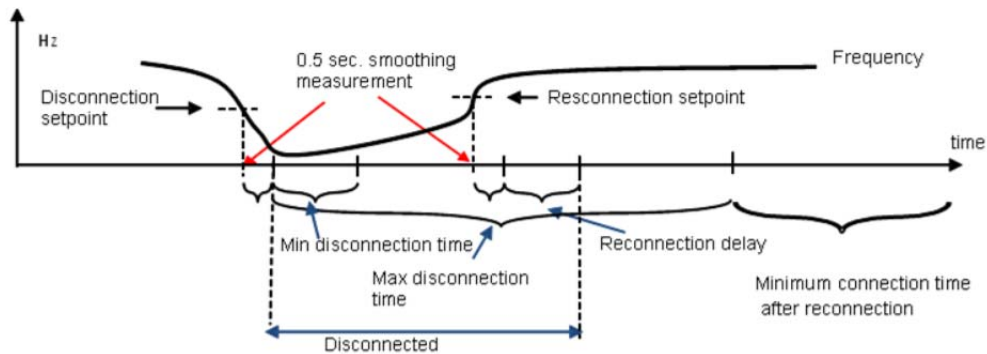

**Figure 15 – Illustrator about SmartBox (source: EA Energianalysis)**

**Table 4 – SmartBox settings**

Parameters	Description
49.900Hz	Disconnect Set point
49.950Hz	Reconnect Set point
2s	Reconnect Delay
10s	Minimum disconnect time
180s	Max disconnect time

360s                      Min connection time after reconnect

Other heat pump models are controlled by logic circuits. The key component of that logic circuit is a comparator. A hysteresis is set as 10s, corresponding to the minimum disconnect time of SmartBox.

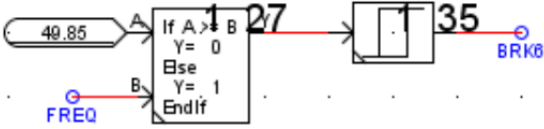

Figure 16 – Logic circuit controller

Such a design determines that the disconnection and reconnection set point are the same to each other. Nevertheless, the actual reconnection point in simulation is also depending on the hysteresis.

3.4.2 Type II control logic application

Three heat pump models are involved in type II control. Each heat pump model will have a unique initial state in simulation. As the same to type I, all heat pump models have the equal capacity. But they operate in relay mode since the high and low temperature set points are needed for type II control logic.

Different from the type I DFR, type II DFR involve both frequency increasing and decreasing events. A variable offset coefficient is applied according to the frequency range

Table 5 – Offset coefficient kf value

Frequency range	Offset coefficient value
f > 50Hz	kf = 20
f < 50Hz	kf = 10

This is in consideration of DFR capacities in different range. When the frequency drops below 49.90Hz, type I logic controlled DFR contribute as reserve. In the range of [49.90Hz, 50Hz], i.e. inside standard frequency deviation, a smaller kf can prevent excessive wear out. Thus a smaller kf is applied to frequency below 50Hz. Unlike frequency decreasing regulation, only type II DFR contribute when frequency increasing above standard range. Therefore the maximum kf should be applied. The heat pump temperature set points are 19 and 21 oC. It means if the offset reaches 2 oC, all the available heat pump DFR will be activated. The frequency deviation of standard range is 100mHz, hence

$$\text{Maximum kf} = \text{maximum offset} / \text{frequency deviation} = 2 / 0.1 = 20 \text{ } ^\circ\text{C}/\text{Hz} \tag{13}$$

In theory, the kf in range [50Hz, 50.10Hz] can be a smaller coefficient. But that may lead to oscillation around the boundary which is not easy to solve by the preliminary model. So the kf in the frequency range above 50Hz is designed as 20 uniformly.

In the Bornholm system model, such a variation of kf is achieved by a logic circuit. The key component is a signal selector.

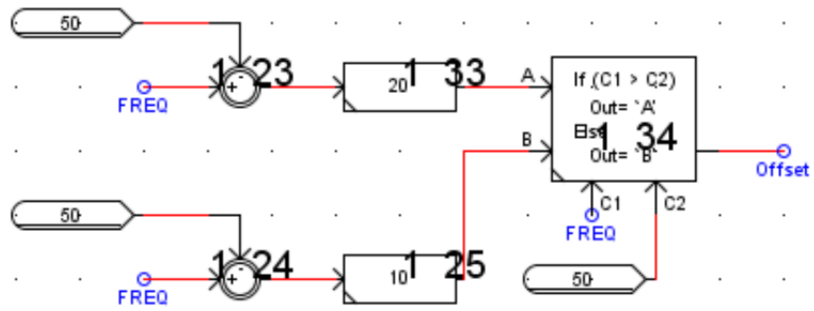

Figure 17 – Logic circuit to generate kf

## 4. Simulation Scenarios

### 4.1 Basic Scenarios

To verify the efficacy of heat pump loads, specific designed changes of system demand are set as contingencies. The Bornholm system model runs in island operation mode for sure. To break the balance between power generation and demand, the method is increasing/decreasing the Hasle dynamic load in this project. The following Table 6 shows the basic scenarios.

**Table 6 – Basic Scenarios with system contingency**

Contingency type	Contingency ratio of total demand	DFR (heat pumps) penetration level			
		0%	2.5%	5.0%	7.5%
System demand increasing	2.5%				
	5.0%				
	7.5%				
System demand decreasing	2.5%				
	5.0%				
	7.5%				

Each contingency type has three levels according to the contingency ratio of total demand. This is defined as the percentage of the disturbance power versus the total system demand, i.e.:

$$\text{Contingency ratio}\% = \frac{P_{\text{disturbance}}}{P_{\text{total}}}\% \quad (14)$$

The summation of total demand is  $P_{\text{total}} = P_{\text{load}} + P_{\text{heat pump}} = 18\text{MW}$ . Pheat pump, the power of heat pumps as DFR, varies in penetration level from 0% to 7.5%. The penetration level here has the similar definition as contingency ratio which is quoted from [2]:

$$\text{DFR penetration level}\% = \frac{P_{\text{heat pumps}}}{P_{\text{total}}}\% \quad (15)$$

Six contingency ratios and four penetration levels are designed. Therefore 24 basic scenarios are included in this project.

The contingency ratios are designed based on the frequency deviation of the original system model without heat pump DFR (0% DFR penetration level). This is related to a classification depending on the Nordic power system network code. In the supporting document for the network code on load-frequency control and reserves from Entso-e, a standard frequency range is used as a basis for system frequency quality. Standard frequency range is defined as the range within which system should be operated for defined time intervals [3]. When it comes to Nordic power system, this frequency quality parameter is defined as  $\pm 100\text{mHz}$ . Therefore, the frequency deviations that caused by contingency events are classified into three ranges:



**Table 7 – Frequency deviation classification**

Deviation range	Description	Disturbance level
$ \Delta f  < 100\text{mHz}$	Deviation that within standard range	Slight
$100\text{mHz} <  \Delta f  < 150\text{mHz}$	Deviation that slightly beyond standard range	Medium
$ \Delta f  > 150\text{mHz}$	Deviation that obviously beyond standard range	Large

One point should be emphasized about the classification. The setting of 150mHz condition is based on the DFR set points controlled with logic type I. As mentioned in section 3.4, the minimum break point of type I DFR is 49.85Hz. In another word, if the system frequency drops more than 150mHz, all the type I controlled DFR should be activated. Thus this condition is specifically designed due to the function of DFR.

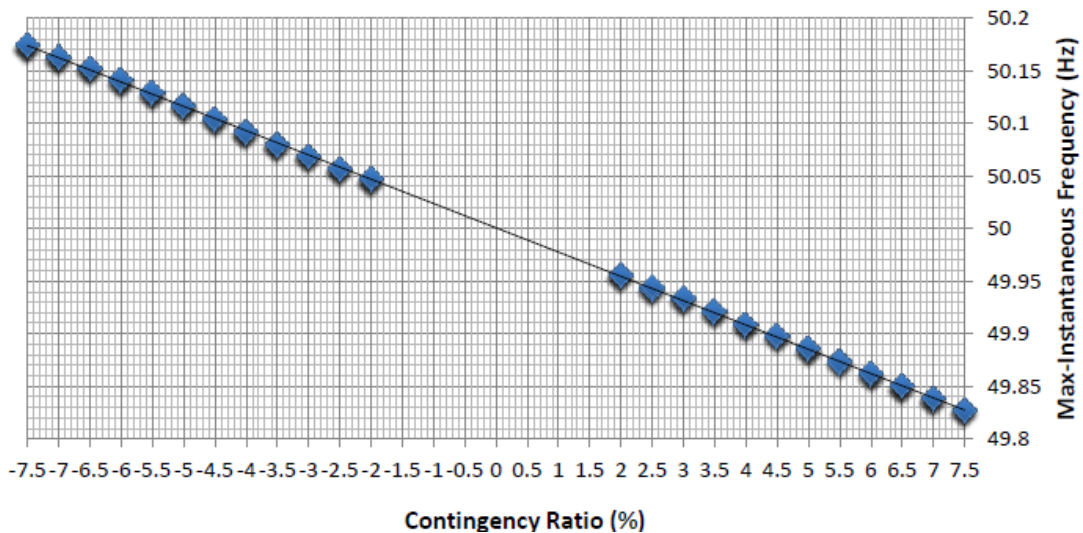

**Figure 18 – Contingency ratio versus frequency**

As mentioned above, several events are simulated with 0% DFR penetration level to decide the contingency ratio. The mean maximum instantaneous frequency of 5 times simulation is focused.

Figure 18 demonstrates that the frequency deviation increases with the contingency ratio. This relationship is linear by intuition. According to the classification principle in Table 9, six contingency ratios are chosen as simulation scenarios.

**Table 8 – Selected contingency ratios**

Contingency ratio	Mean Max-Instantaneous f	Frequency deviation
-------------------	--------------------------	---------------------

Demand increasing 2.5%	49.943Hz	57mHz
Demand increasing 5.0%	49.886Hz	114mHz
Demand increasing 7.5%	49.827Hz	173mHz
Demand decreasing 2.5%	50.057Hz	57mHz
Demand decreasing 5.0%	50.116Hz	116mHz
Demand decreasing 7.5%	50.174Hz	174mHz

With contingency ratio 2.5%, both demand increasing and decreasing, the system frequency deviation is within the standard frequency range. For the scenarios with this contingency ratio, the simulations aim to investigate how the heat pump reserves response to slight disturbance. The control strategy dead band and the appliances extra wear-out shall be discussed. With contingency ratio 5.0%, both demand increasing and decreasing, the system frequency deviation is slightly beyond the standard frequency range. For the scenarios with this contingency ratio, the simulations aim to investigate how the heat pump reserves response to medium disturbance. The hardware in the loop test will be focused. The ability of DFR to limit the frequency deviation to the standard frequency range shall be discussed. For the contingency ratio 7.5%, the system frequency deviation is obviously beyond the standard range and all the DFR reserves are supposed to be activated. These scenarios are regarded as severe events which test the maximum frequency regulation ability of heat pump reserves.

Four different DFR penetration levels are carried out at 0%, 2.5%, 5.0% and 7.5% in simulation. It reflects the heat pump capacity changing in real life. The 0% penetration level is regarded as control group since it represents no demand reserve. The efficacy of different penetration levels shall be compared and discussed. As indicated in [2], the complexity of real situation makes it way too difficult to simulate the actual power of heat pump consumption. The installed capacity is used in quantifying the amount of DFR heat pumps. The actual power of DFR heat pumps should be smaller than the levels defined. In real operation, the experience value of power consumption could be effective due to the heat pump's usage is relatively regular.

## 4.2 Simulation settings

Each scenario comes down to five times of repeated 150 seconds real-time simulation process. A starting-up stage of generators occurs right after the simulation begins. The system frequency oscillates initially and then recovers to nominal value. A stable nominal frequency is one of the preconditions for the contingency events. Besides, the starting-up oscillation could activate the SmartBox's control action and make it locked at least as long as its own minimum turn on/off time. Therefore the SmartBox should be reset at stable nominal frequency. While the two conditions above are ensured, the contingency is triggered by changing the load manually. The contingency kicks in after 12 seconds pre-trigger time.

## 5. Results and Discussion

### 5.1 Results demonstration

In this part, the result analysis and data collection method will be demonstrated. The simulation result of scenario '7.5% demand increasing; 2.5% DFR penetration level' will be presented as an instance. System frequency analysis is the highlight in this project. The following figure shows the track of system frequency of the scenario.

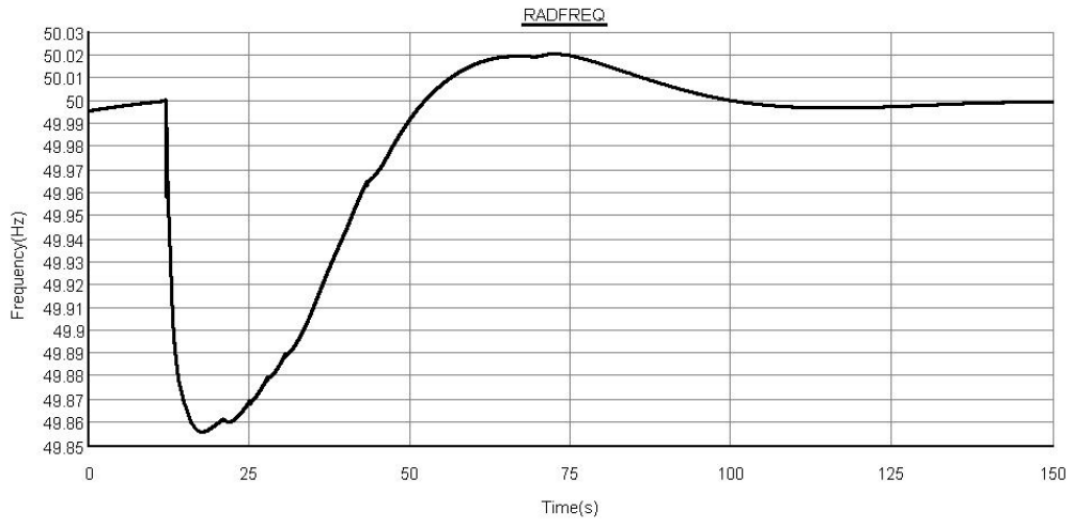
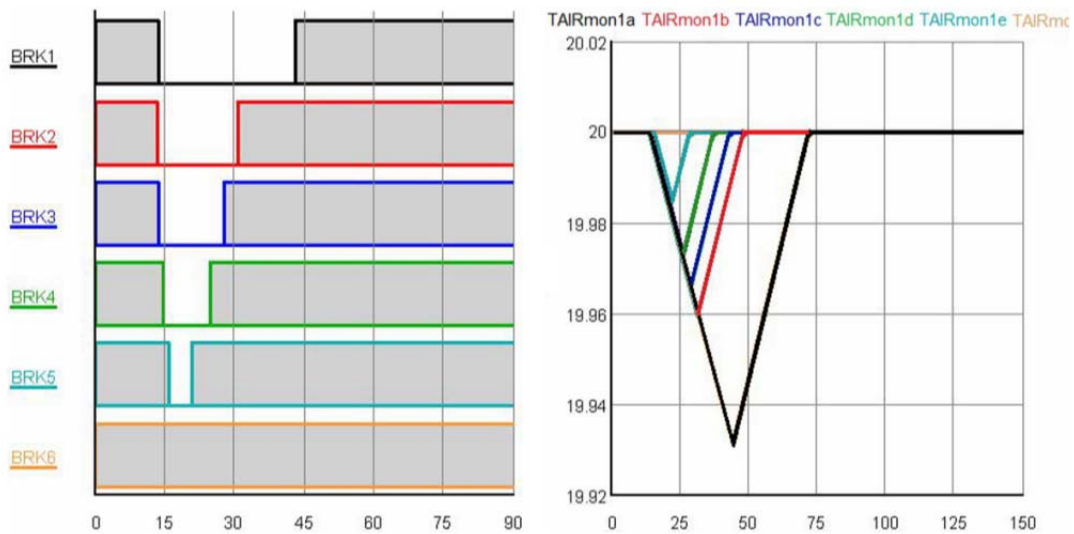

Figure 19 – System frequency curve of the scenario

Using the graphic tracer, the specific parameters can be read from the figure. In primary frequency control, the maximum instantaneous frequency deviation reflects the quality. In this scenario, we get  $\Delta f_{max} = 144\text{mHz}$  at 17.822s. The same process repeats 5 times. A mean frequency deviation is calculated to eliminate the error. Generally, there is only  $\pm 1\text{mHz}$  variation of 5 times simulations for each scenario. Such variation is supposed to be caused by minor oscillation in initial frequency. Just like in Figure 19, the frequency rises from 49.997Hz to 50Hz during the pre-trigger period.

The reaction mechanism of heat pump reserve has been introduced in section 3.4. To prove the mechanism operating normally, several parameters are fully monitored. For heat pump reserves controlled by logic type I, breakers' switching on/off condition and each group's house air temperature are observed.



**Figure 20 – Breakers statuses and house air temperature**

Figure 20 assembles the action of breakers and the corresponding house air temperature trend. A comparison between breakers actions and the system frequency can be made when we try to verify the mechanism of type I DFR control. The behavior of hardware – SmartBox, will be deliberated in the discussion part in particularly. It is quite clear that the house air temperature drops in the corresponding breaker turned off period. In theory, if the heat pumps are turned off by DFR mechanism for 180 seconds, then the controlling device will automatically turn it on. The customer satisfaction will be discussed. But in this project, the frequency recovery is too fast to keep the breakers turned off more than 180 seconds. The air temperature just fluctuates slightly in the normal range. Therefore the temperature change in type I control is not a necessary point.

Figure 21 assembles the house air temperature trend and the temperature set point offset of heat pump controlled by logic type II. As clarified in section 3.3, the offset is proportional to frequency deviation. That is the reason that the offset curve has the same shape as frequency curve. From the temperature graphic, we can verify that how the offset affects the heat pump operation. On contrast to DFR with type I control logic, the effectiveness of type II control is closely related to heat pump temperature. Therefore the temperature change will be one highlight to discuss.

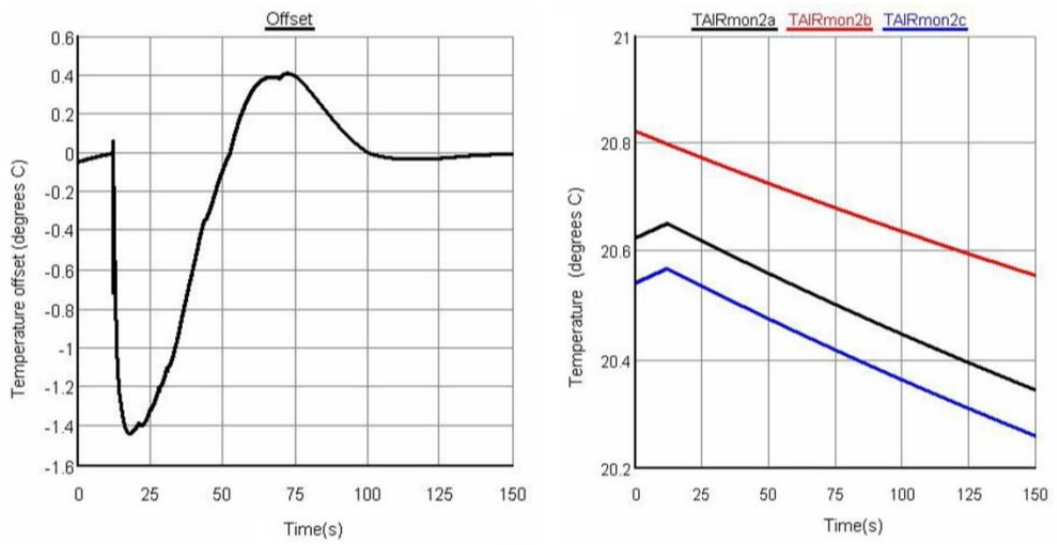

Figure 21 – Offset and house air temperature

### 5.2 Frequency regulation efficacy

The simulated system frequency results are presented in 6 groups based on contingency ratios in Figure 22 to Figure 27.

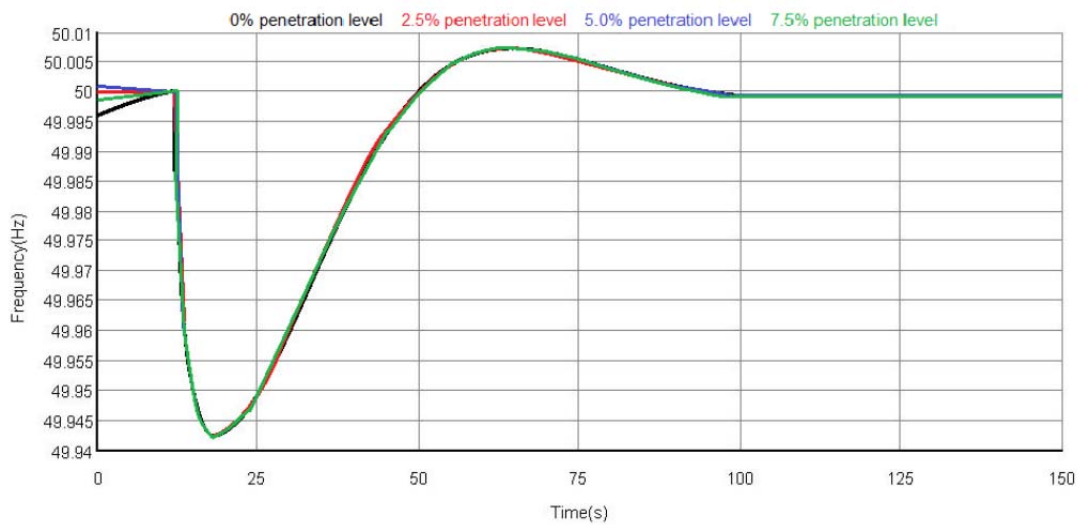
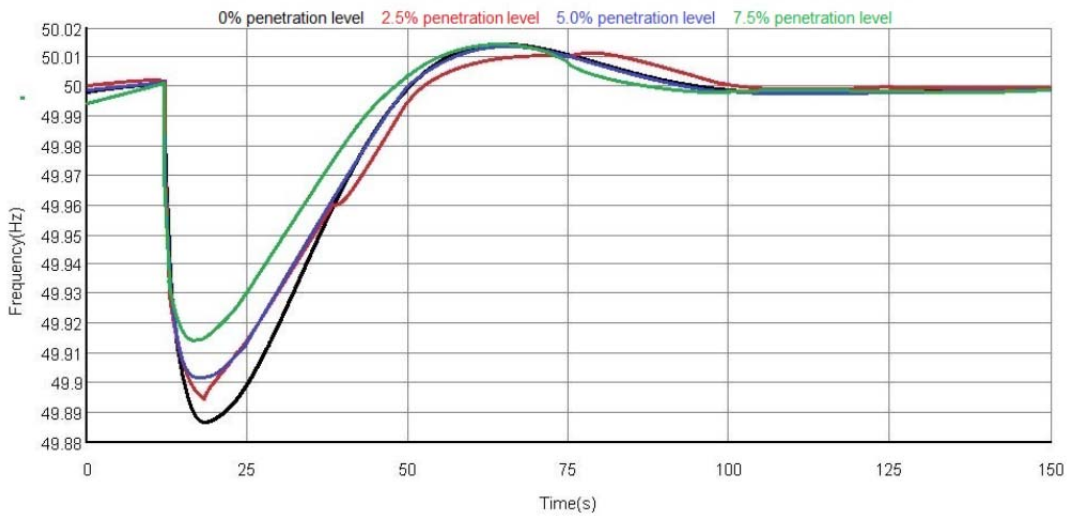
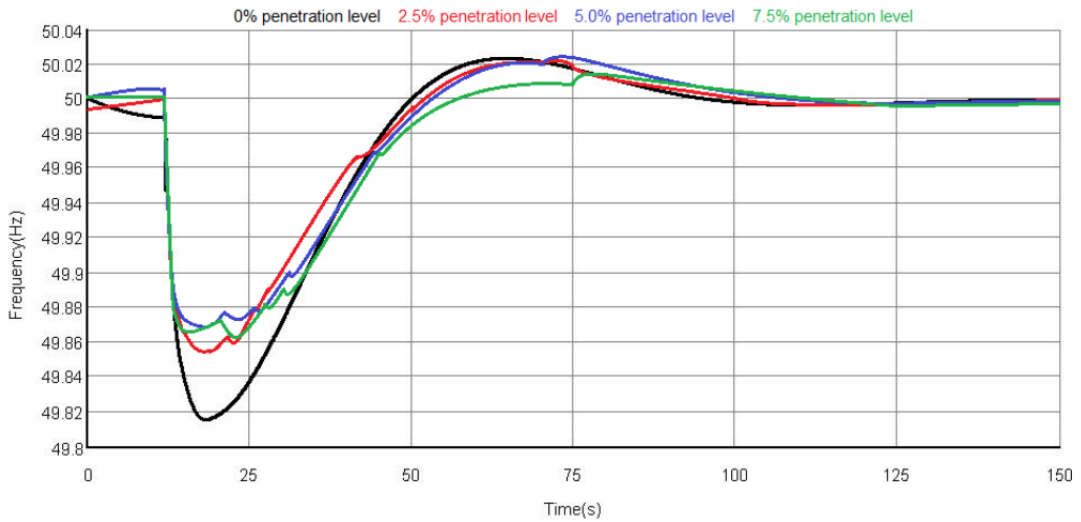

Figure 22 – System frequency with 2.5% demand increasing



**Figure 23 – System frequency with 5.0% demand increasing**



**Figure 24 – System frequency with 7.5% demand increasing**

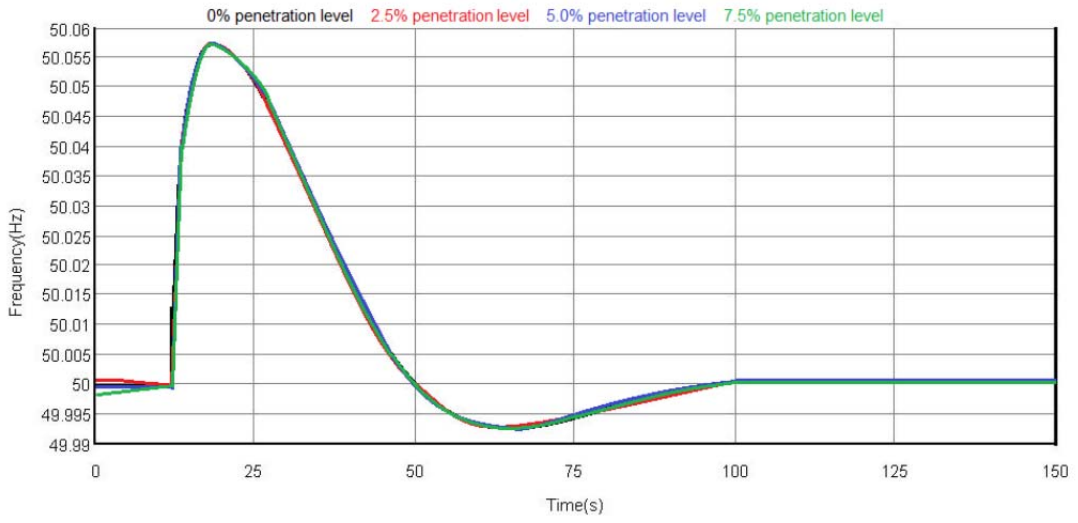

**Figure 25 – System frequency with 2.5% demand decreasing**

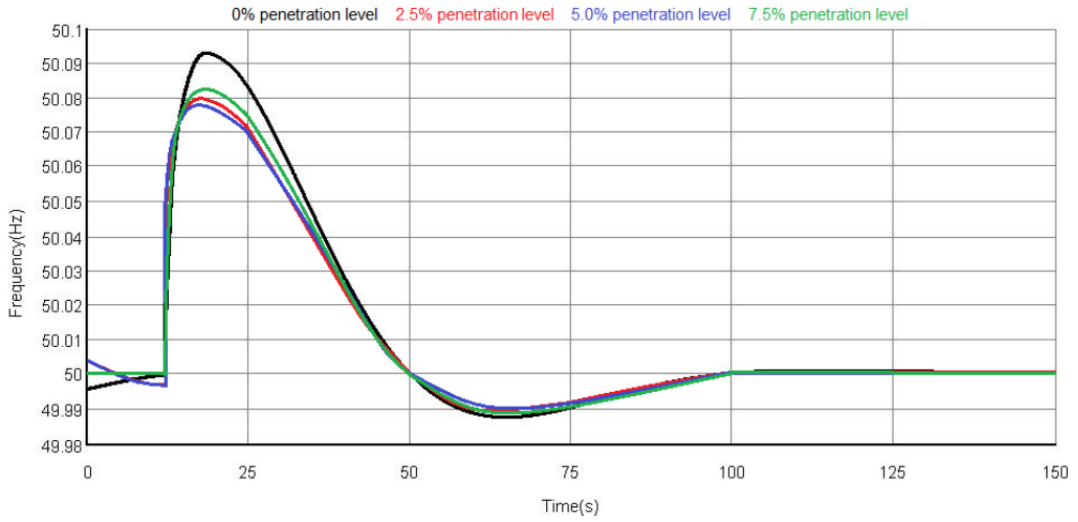

**Figure 26 – System frequency with 5.0% demand decreasing**

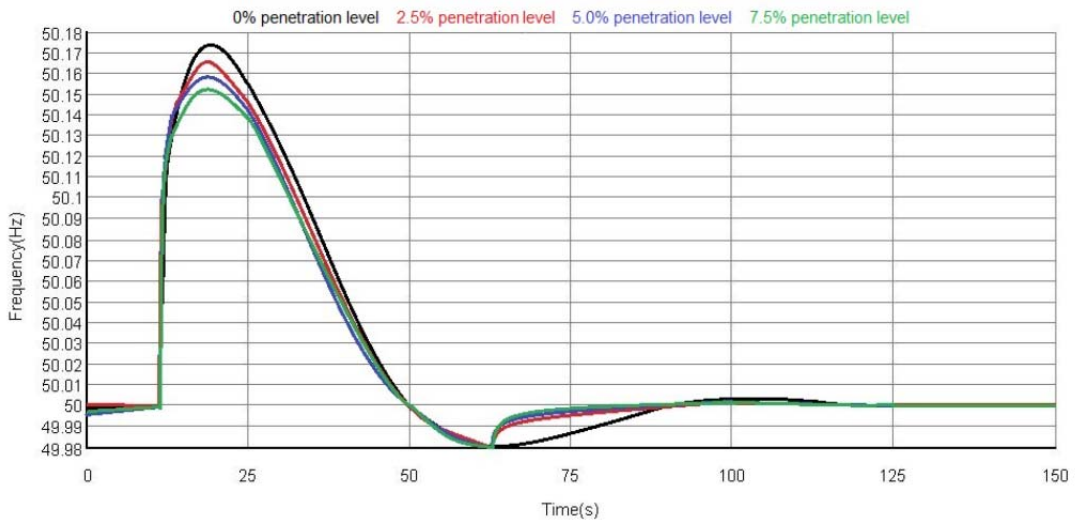

**Figure 27 – System frequency with 7.5% demand decreasing**

The data derived from the simulation results are elaborated in order to extract the most interesting information. To study the frequency regulation efficacy of heat pump reserve, the maximum instantaneous frequency deviation and corresponding observation time are mostly concerned.

### Demand Increasing scenarios

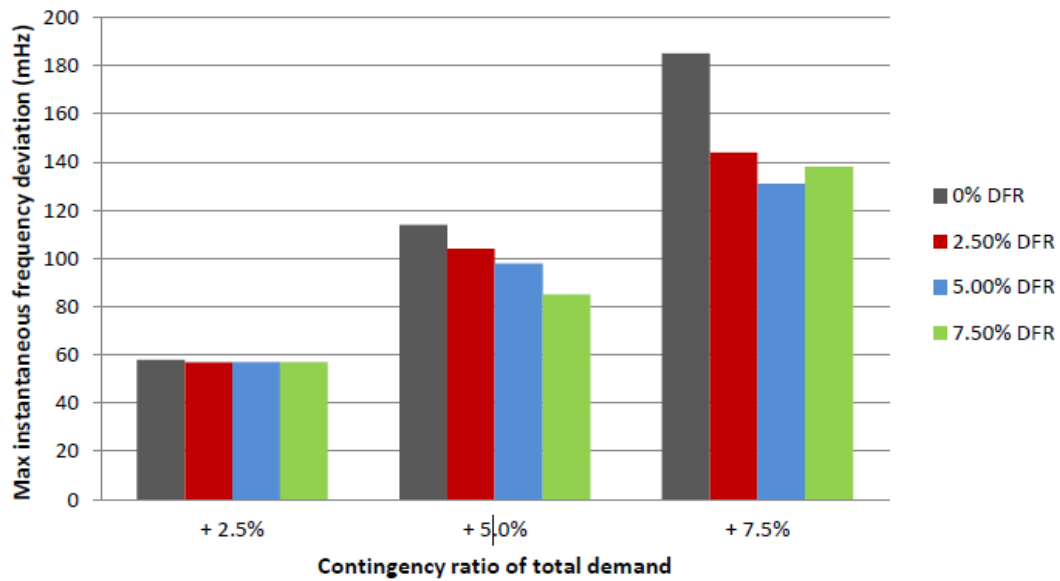

**Figure 28 – Frequency histogram of demand increasing scenarios**

Figure 28 gives a visualized expression on the efficacy of heat pump DFR from frequency deviation aspect. The Bornholm system with heat pump DFR has an obviously smaller frequency deviation when dealing with demand increasing. For instance, when dealing with 5% demand increasing, the frequency deviation is reduced from 114mHz to 104mHz, 98mHz and 85mHz respectively by 2.5%, 5.0% and 7.5% DFR penetration. Though slight disturbance such as 2.5%



in the figure above seems like an exception. This phenomenon will be discussed in section 5.3.3. In theory, for a specific contingency, a larger DFR penetration level brings smaller frequency deviation. This is proved by most simulation cases, but not the '7.5% DFR; +7.5% demand' case in the figure above. It is related to oscillation caused by reconnection of type I logic controlled heat pumps. It will be focused in section 5.3.4.

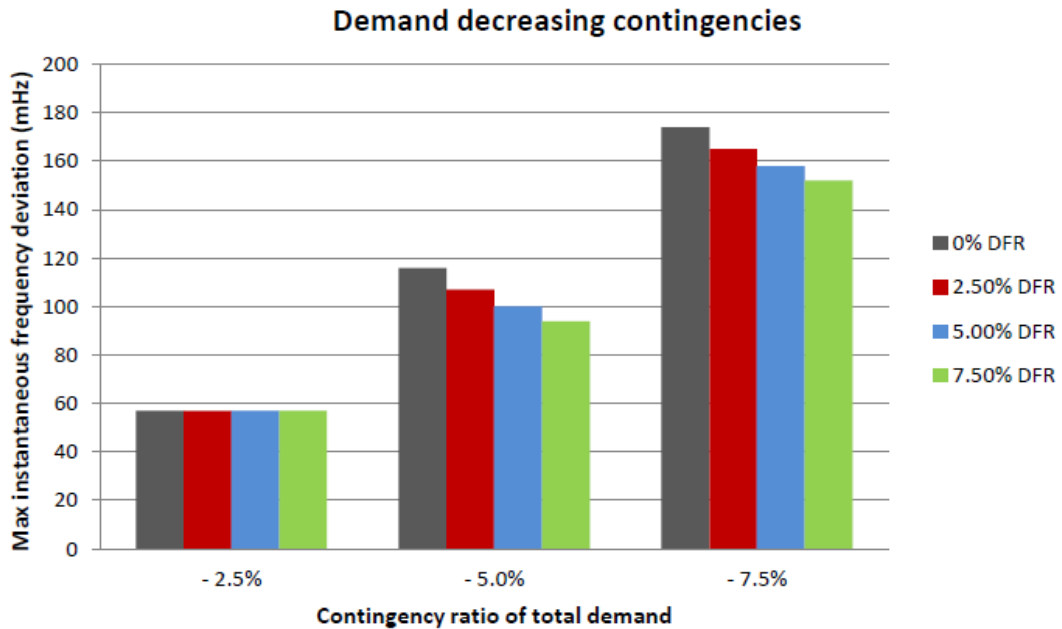

Figure 29 – Frequency histogram of demand decreasing scenarios

Quite similar to the last figure, Figure 29 proves that heat pump DFR is effective on regulating frequency deviation with demand decreasing contingencies. It is worthy emphasizing that only type II logic controlled heat pumps played a role in these scenarios. Same to the increasing part, the DFR's omission on slight disturbance will be discussed in section 5.3.4. In spite of it, the Bornholm system with heat pump DFR has an obviously smaller frequency deviation when dealing with demand decreasing. For instance, when dealing with 7.5% demand decreasing, the frequency deviation is reduced from 174mHz to 165mHz, 158mHz and 152mHz respectively by 2.5%, 5.0% and 7.5% DFR penetration.

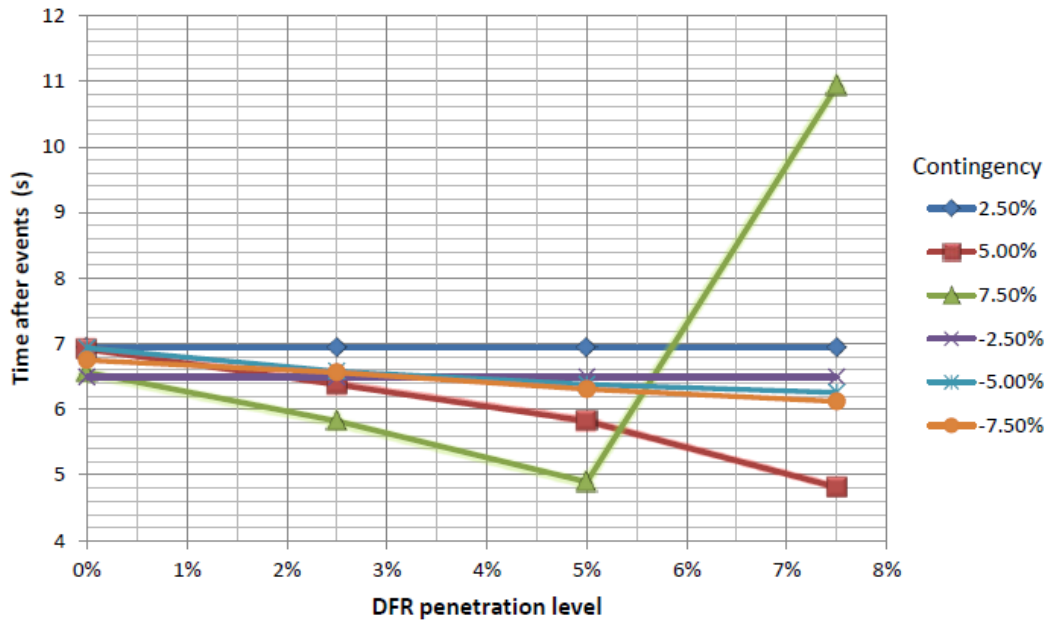

Figure 30 – Frequency deviation observation time versus penetration levels

Figure 30 shows the trend of observation time versus penetration levels. As mentioned above, the oscillation caused by reconnection of type I logic controlled heat pumps make the result of scenario ‘7.5% contingency ratio; 7.5% penetration level’ quite abnormal, so does it on observation time aspect. If we eliminate that point temporarily, the trend of observation time is quite clear. In general, for a specific contingency, larger DFR penetration level makes shorter observation time.

### 5.3 Specific discussions

#### 5.3.1 Introduction

Section 5.2 verifies the efficacy of heat pump DFR. In this part, hardware-in-the-loop performance is focused. Some specific cases which bring contradiction to the general conclusion will be further investigated. The advantage and weakness of heat pump DFR can be clarified through these specific discussions.

#### 5.3.2 Hardware-in-the-loop test performance

The performance of hardware in the loop test is mainly analyzed through the actions of virtual control object – breaker 1. As introduced in section 3.3, the disconnection set point of breaker 1 is 49.90Hz. Compared to other virtual breakers in the system, an action lag of breaker 1 is noticeable.

The scenarios with 7.5% contingency ratio present that point quite clearly.

Table 9 – Disconnection time details of breakers in 7.5% contingency

Penetration level	f reaches 49.90Hz	Breaker 1 disconnection time	Breaker 2 disconnection time

2.5%	13.180 second	13.889 second	13.333 second
5.0%	13.552 second	14.167 second	13.889 second
7.5%	13.730 second	14.333 second	14.106 second

A common phenomenon is observed which the disconnection time of breaker 1 is later than that of breaker 2. It is not theoretically interpretable in control logic since the frequency reaches 49.90Hz earlier than 49.91 Hz. In fact, the signal transmission between SmartBox and RTDS simulator leads to such a time delay. According to the results, the lag range is approximately from 0.58 to 0.72 seconds. This is inevitable.

When it comes to primary frequency control, a demand frequency reserve is requested to respond quickly. A serious time delay could weaken the regulation efficacy. To test whether the SmartBox is qualified, an extra simulation case is added. It is based on the scenario '5% demand increasing; 2.5% DFR penetration level'. In the original case, type I and type II DFR cooperate to regulate the system frequency. In type I control process, only breaker 1 is disconnected due to frequency decreasing. The additional case aims to investigate how the frequency quality changes without hardware controlled DFR. So the breaker 1 is locked on in the simulation while only type II logic controlled DFR functions.

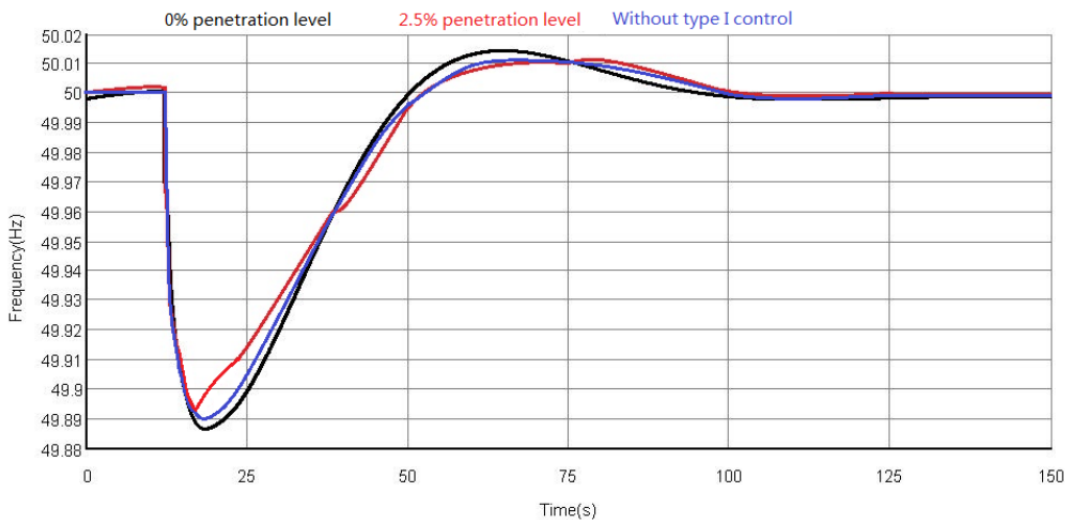

Figure 31 – Frequency comparison

The blue curve in the figure above shows the frequency trend of this additional case without hardware controller. Compared to the red curve – original frequency trend, the maximum deviation is larger which suggests worse frequency regulation efficacy. In other words, it proves that the hardware controller succeed in carrying out the type I control logic for heat pump DFR.

### 5.3.3 Heat pump DFR responding to slight disturbance

Simulation results demonstrate a phenomenon that the heat pump DFR cannot respond to slight disturbance, for instance 2.5% demand change. This is actually incomprehensive due to the mechanism of type II control. The scenario with 2.5% load decreasing and 7.5% DFR penetration level is analyzed as sample.

Figure 32 assembles the house air temperature trend and the temperature offset. The largest offset 1.18 °C occurs at the maximum frequency deviation. At that moment, for all the three heat pump groups, their temperature stands inside the offset. Therefore none of them responds to the frequency deviation. Thus the DFR mechanism seems to be out of work. To verify it, an additional simulation is designed. The initial state of heat pump group C is changed to '19.8 °C, turned off'. The heat pump group C is supposed to be turned on responding to the frequency deviation. Figure 33 and Figure 34 shows the simulation result.

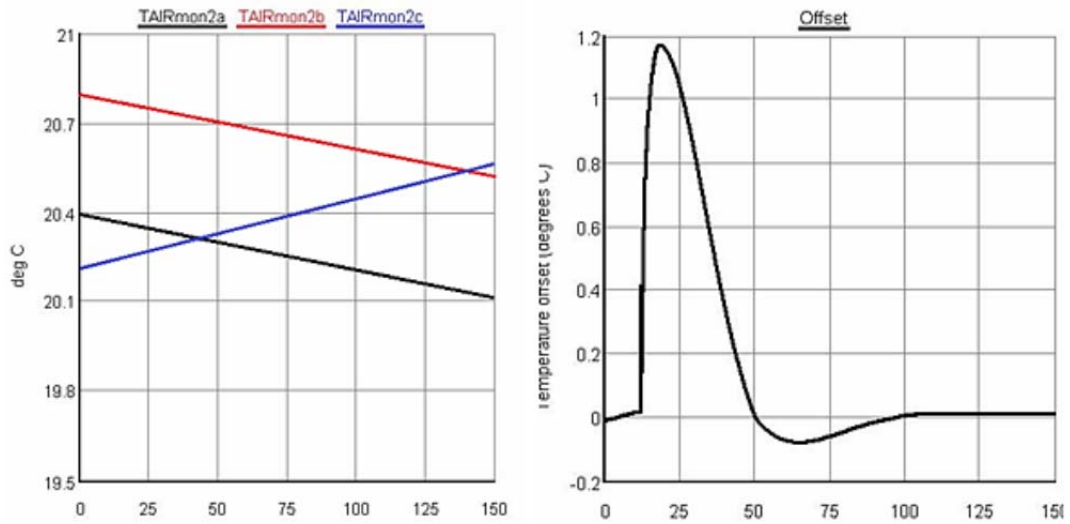

Figure 32 – Original offset and house air temperature

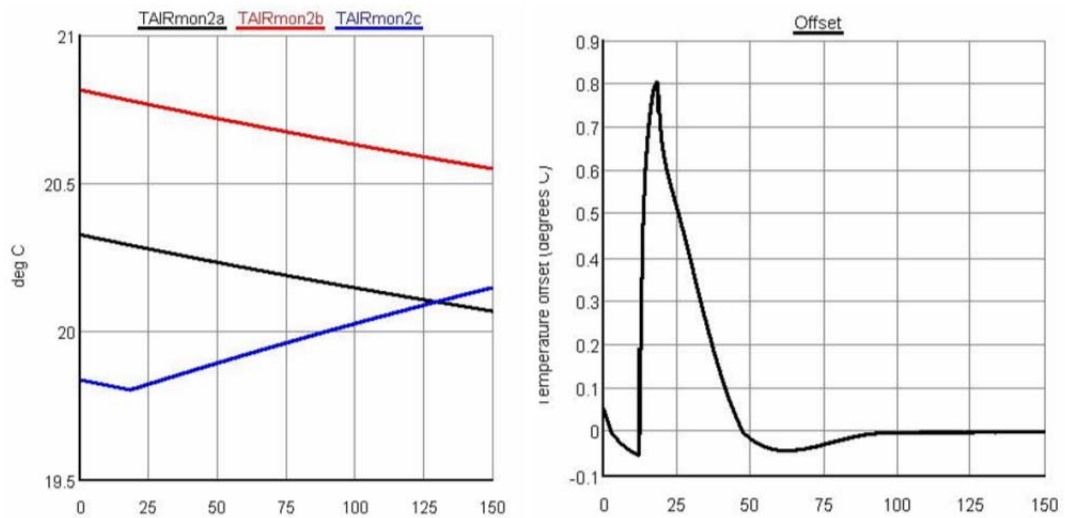
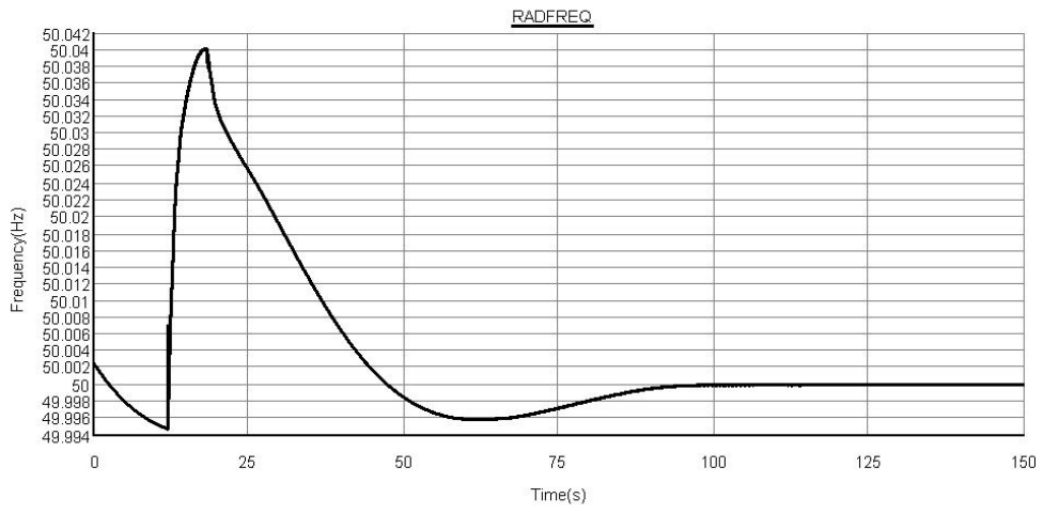

Figure 33 – Additional simulation results



**Figure 34 – Additional simulation frequency result**

The result confirmed the analysis above. Heat pump group C responds to the frequency deviation and carries out as DFR. The max frequency deviation is reduced from 50.056Hz in original scenario to 50.041Hz. This phenomenon demonstrates that adequate diversification of heat pump initial state could be an important condition, though it brings extra load to simulator. In the point of view of appliances, it reduces the probability of excessive wear outs since only few heat pumps are activated.

### 5.3.4 High penetration level oscillation

When the penetration level is high, the reconnection of heat pump type I logic controlled DFR could be regarded as considerable disturbance. It is like a ‘return energy’. That is because heat pumps with the same set point will reconnect to the system simultaneously. Unlike type I, type II logic reconnects demand more smoothly. It is due to the continuous change of offset and discrete states of heat pumps. One effective method to solve this problem is setting reconnection hysteresis. The frequency decreases rapidly thus the breakers switching off in a short period. Owing to that, if appropriate reconnection hysteresis can be set to breakers, simultaneous reconnection of many heat pumps can be prevented. Such design benefits from the advantage of heat pumps – shortly disconnection, even with dozens seconds of reconnection hysteresis, bringing limited disturbance to appliances and customer satisfaction.

### 5.3.5 FCR requirements discussion

The results and discussions above prove that heat pump DFR is valid on frequency regulation. Now we look back to the FCR minimum technique requirements.

- Maximum combined effect of inherent Frequency Response Insensitivity and possible intentional Frequency Response Dead band of the governor of the FCR is no larger than 10mHz
- FCR full activation time is no more than 30s after the frequency is outside the standard frequency range
- FCR full activation deviation is no more than  $\pm 500$ mHz

From the results we can see that the second and third requirement are completely fulfilled by heat pump DFR. The full activation time is typically no later than 4.0 second after the frequency is outside the standard range. The full activation deviation is -150mHz and 0Hz s designed.

In section 5.3.3, the additional simulation indicates that if there are large numbers of heat pumps distributed uniformly in the temperature range, the type II control doesn't have such a dead band. Therefore, this requirement is predictable fulfilled in reality.

## 6. Conclusion

In this project, the efficacy of heat pumps as Demand frequency reserve is tested. Heat pump models are installed in Bornholm system model in RTDS. Hardware-in-the-loop test are carried out with SmartBox. Two control logics are applied to heat pump models. The network code from Entos-e is use as the standard to evaluate the results.

The result shows that heat pump is qualified as demand frequency reserve. It provides primary frequency control service without degrading the customer comfort. Nevertheless, high penetration level if type I logic controlled DFR may lead to oscillation due to 'return energy'. This project provides suggestions on this issue but no specific solution. That could be a future perspective. The sensitivity of heat pump DFR is proved by additional simulations and expound the viewpoint that diversification of type II heat pump initial value is quite important to the DFR quality. At last, the simulation results are evaluated with FCR minimum technique requirements from network code on load – frequency control. The heat pump demand frequency reserve is qualified as frequency containment reserve in Nordic power system.

## 7. Bibliography

- [1] Xu, Zhao, Jacob Ostergaard, and Mikael Togeby. "Demand as frequency controlled reserve." *Power Systems*, IEEE Transactions on 26.3 (2011): 1062-1071.
- [2] Xu, Zhao, Jacob Ostergaard, and Mikael Togeby. "Demand as frequency controlled reserve final report for the PSO project." Technical University of Denmark and EA energianalysis, September 2008.
- [3] Fin grid, Maintenance of Frequency. [Online]. Available : [http://www.fingrid.fi/portal/in\\_english/services/system\\_services/maintenance\\_of\\_frequency](http://www.fingrid.fi/portal/in_english/services/system_services/maintenance_of_frequency).
- [4] M. Bailey, "Provision of frequency responsive power reserve from disconnectable load," *Proc. IEE Colloq. Economic Provision of a Frequency Responsive Power Reserve Service* (98/190), pp. 5/1–5/5, Feb.1998.
- [5] M. Kintner-Meyer, R. Guttromson, D. Oedingen, and S. Lang, *Final Report for California Energy Commission: Smart Load and Grid-Friendly Appliances*, Architecture Energy Corporation and Battelle Memorial Institute, 2003.
- [6] Philip J. Douglass, Rodrigo Garcia-Valle, Preben Nyeng, Jacob Østergaard, Mikael Togeby, "Demand as frequency controlled reserve: Implementation and practical demonstration", 2011 2nd IEEE PES International Conference and Exhibition on "Innovative Smart Grid Technologies".
- [7] Jacob Østergaard and John Eli Nielsen, "THE BORNHOLM POWER SYSTEM An overview 14th edition", Centre of electrical technology, Technical University of Denmark, April 2011.
- [8] Wei Ren, "Accuracy Evaluation of Power Hardware-in-the-Loop (PHIL) Simulation", Florida State University, PHD thesis, 07.02.2007.
- [9] Douglass, P., et al. "Demand as frequency controlled reserve: Implementation and practical demonstration." *Innovative Smart Grid Technologies Europe* (2011).
- [10] "Supporting Document for the Network Code on Load-Frequency Control and Reserves", European Network of Transmission System Operators for Electricity, 28.06.2013
- [11] "Network Code on Load-Frequency Control and Reserves", European Network of Transmission System Operators for Electricity, 28.06.2013.
- [12] Xu, Zhao, Jacob Ostergaard, and Mikael Togeby. "Design and modeling of thermostatically controlled loads as frequency controlled reserve", in *Proc.2007 IEEE PES General Meeting*.
- [13] Jakob K. Zimmermann, Qiuwei Wu and Jacob Østergaard, "Documentation and test of RTDS Hardware in the loop with DFR SmartBox ", Department of Electrical Engineering, Elektrovej, Building 325, DK-2800 Kgs. Lyngby, Denmark. 2013
- [14] Seung Tae Cha, Haoran Zhao, Qiuwei Wu, Jacob Østergaard, Torben S. Nielsen, Henrik Madsen, "Evaluation of Energy Storage System to Support Danish Island of Bornholm