

Technical University of Denmark



Effect of process parameters on the dryness of molded pulp products

Didone, Mattia; Tosello, Guido

Published in:
Proceedings of Progress in Paper Physics Seminar 2016

Publication date:
2016

Document Version
Peer reviewed version

[Link back to DTU Orbit](#)

Citation (APA):
Didone, M., & Tosello, G. (2016). Effect of process parameters on the dryness of molded pulp products. In Proceedings of Progress in Paper Physics Seminar 2016

DTU Library

Technical Information Center of Denmark

General rights

Copyright and moral rights for the publications made accessible in the public portal are retained by the authors and/or other copyright owners and it is a condition of accessing publications that users recognise and abide by the legal requirements associated with these rights.

- Users may download and print one copy of any publication from the public portal for the purpose of private study or research.
- You may not further distribute the material or use it for any profit-making activity or commercial gain
- You may freely distribute the URL identifying the publication in the public portal

If you believe that this document breaches copyright please contact us providing details, and we will remove access to the work immediately and investigate your claim.

Effect of process parameters on the dryness of molded pulp products

DIDONE MATTIA, TOSELLO GUIDO

Technical University of Denmark, Department of Mechanical Engineering, 2800 Kgs. Lyngby, Denmark

matdid@mek.dtu.dk

ABSTRACT

Molded pulp products are made from cellulose fibers dispersed in water then formed, drained and dried. As in the conventional papermaking process, the most energy intensive operation (including time) is drying. To gain a better understanding of the process parameters involved and to investigate their influence on the final product's dryness, two experimental plans were designed and analyzed by means of design of experiments (DOE).

A numerical simulation of the heat model was developed with the aim of finding the process time window.

1. MATERIALS

Test rig

The laboratory-molding machine (Figure 1) is capable of press dry a preformed paper disk of Ø100 mm. The upper half of the mold is fixed to the outer frame and is heated up to the imposed temperature. The bottom half of the mold is moved upwards by a double acting cylinder and it consists of a backing plate placed on top of a vacuum plate. 90% vacuum (i.e. 101,3 mbar in absolute pressure) is applied for a defined time in order to dry the paper disk.

Process steps:

1. Pressure is increased until the imposed limit (**p**).
2. Pressure and temperature (**T**) are kept constant for a certain time (holding time, **ht**).
3. Vacuum is applied while the mold is kept closed (vacuum time, **vt**).
4. Pressure is released by moving down the bottom half of the mold.

The variables, or factors, object of the DOE investigation are highlighted in bold.

Pulp characteristics

The pulp type used for the experiments is Kraft birch, with an average fiber length of 1 mm and width of 20 µm. Drainability is 20°SR and the water retention value is 1,078 g/g.

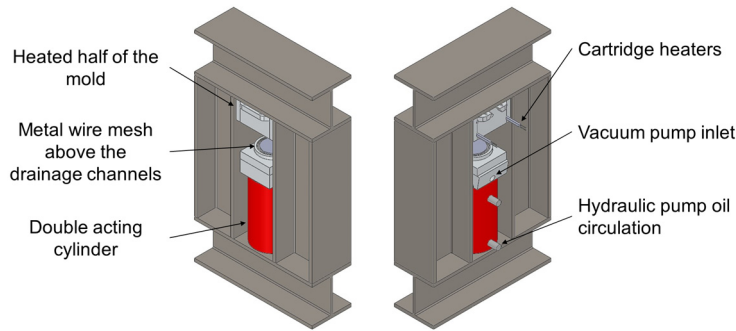

Figure 1: Scheme of the test rig used for press-dry the paper disks

2. NUMERICAL SIMULATION

A numerical simulation of the heat model was developed with the aim of finding the process time window. The heat is predominantly transferred from the mold to the paper disk by means of conduction along the thickness direction. The rate equation that appropriately quantifies the heat conduction is known as Fourier's law, and for the 1-D case is as follows:

$$q_x'' = -k \frac{dT}{dx} \quad (1)$$

The equation was modelled using Crank-Nicolson method. The considered domain consists of the paper disk and the bottom half of the mold. The domain enmeshment and the boundary conditions can be seen in Figure 2.

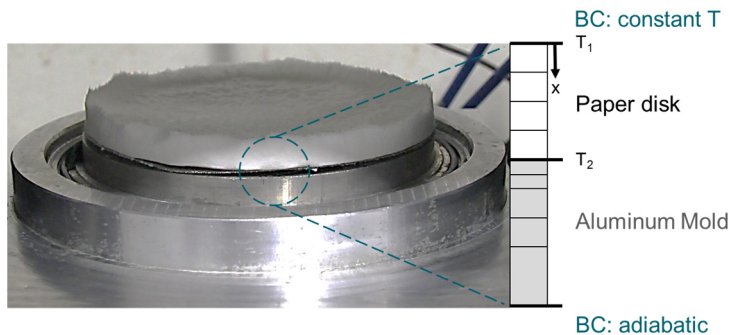

Figure 2: 1-D enmeshment of the paper disk and the aluminum mold to get the process time window via numerical simulation

The effective thermal conductivity of the paper pulp was estimated according to Maxwell's equation [1]. The results are reported in Table 1.

Table 1: Inputs and results of the numerical simulation

Upper mold T ₁ [°C]	Initial paper T ₂ [°C]	Final paper T ₂ [°C]	Time [s]
110	25	55	34,5
160	25	80	41,3
210	25	105	44,8

3. DESIGN OF EXPERIMENTS (DOE)

Processing conditions are mainly characterized by the molding temperature, pressure and process time [2]. To investigate the influence of these variables on the final dryness of the paper disks, two experimental plans were designed and analyzed by means of design of experiments (DOE). The hypothesis of the model have been checked according to ANOVA.

The dryness is seen as an efficiency of the process, i.e. the amount of water removed by the drying process with respect to the ideal amount:

$$dryness = \frac{m_{wet} - m_{disk}}{m_{wet} - m_{dry}} \quad (2)$$

Two experimental plans were performed, in which different factors were kept fixed and the others varied. The main effects plot and the interaction plot for the two plans can be seen in Figure 3 and Figure 4 respectively.

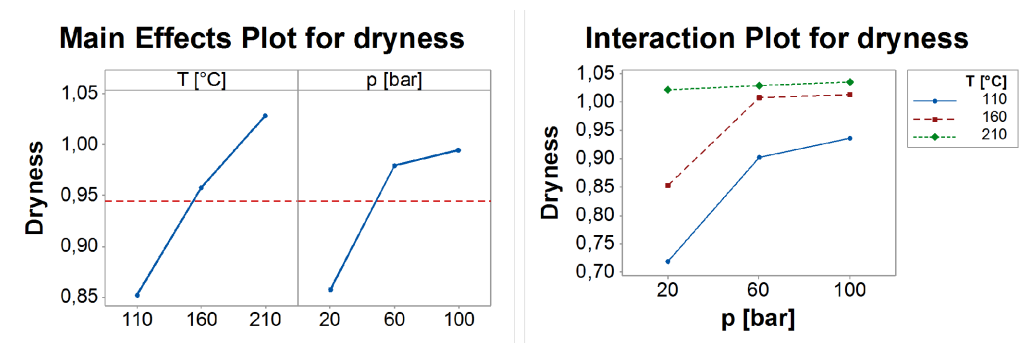

Figure 3: Main effects and interaction plot for the response dryness. First experimental plan, fixed holding time (5 s) and vacuum time (15 s).

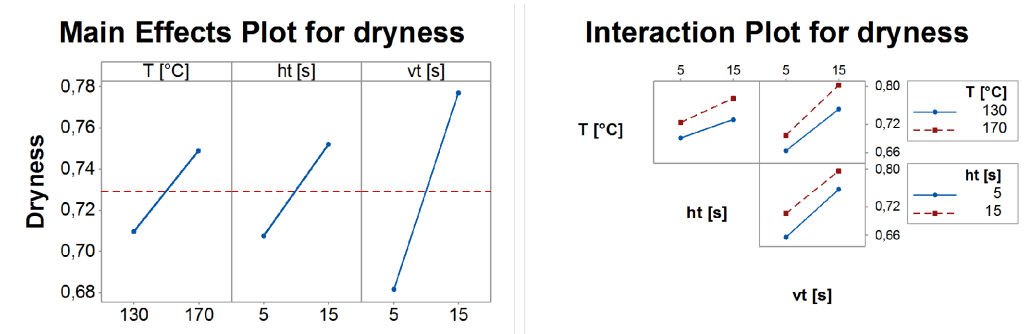

Figure 4: Main effects and interaction plot for the response dryness. First experimental plan, fixed pressure of 50 bar.

4. CONCLUSIONS AND OUTLOOK

- The numerical simulation showed that the process time can be shortened if both the halves of the mold are heated.
- After a certain limit, the pressure is no more beneficial for the drying process. This evidence is in accordance with the assumption given in [3], i.e. the energy transfer is independent of the pressure if the applied pressure is above 30 bar.
- The increasing of the temperature is beneficial, but a good compromise has been reached around 160°C.

ACKNOWLEDGMENT

Support from Innovation Fund Denmark, funding a consortium between DTU Mechanical Engineering, EcoXpac and Carlsberg Group, is gratefully acknowledged. Particularly, the authors express their gratitude to Christian Carlsen and all the EcoXpac team for invaluable experimental assistance.

AUTHOR INFORMATION



Mattia Didone, PhD Student
Technical University of Denmark, Department of Mechanical Engineering
Address: Produktionstorvet
Building: 427, 314
2800 Kgs. Lyngby, Denmark
ORCID: 0000-0002-5353-7333
E-mail: matdid@mek.dtu.dk
Homepage: <http://www.mek.dtu.dk>
Phone: +45 45254803

LITERATURE

- [1] M. Karlsson, *Papermaking Part 2, Drying*. TAPPI, 2000.
- [2] S. T. Seana, B. Sanschagrina, B. V Koktab, and D. Maldasb, "Effects of processing variables on the mechanical properties of compression molded polystyrene-wood fiber composites," *Die Angew. Makromol. Chemie*, vol. 184, no. 3128, pp. 157–166, 1991.
- [3] J. Nilsson and S. Stenström, "Modelling of Heat Transfer in Hot Pressing and Impulse Drying of Paper," *Dry. Technol.*, vol. 19, no. 10, pp. 2469–2485, 2001.