



PVNET.dk - Final Report

Yang, Guangya; Kjær, Søren Bækthøj; Frederiksen, Kenn H. B.; Ipsen, Hans Henrik ; Refshauge, Rasmus Høyrup

Publication date:
2016

Document Version
Publisher's PDF, also known as Version of record

[Link back to DTU Orbit](#)

Citation (APA):
Yang, G., Kjær, S. B., Frederiksen, K. H. B., Ipsen, H. H., & Refshauge, R. H. (2016). PVNET.dk - Final Report.

DTU Library

Technical Information Center of Denmark

General rights

Copyright and moral rights for the publications made accessible in the public portal are retained by the authors and/or other copyright owners and it is a condition of accessing publications that users recognise and abide by the legal requirements associated with these rights.

- Users may download and print one copy of any publication from the public portal for the purpose of private study or research.
- You may not further distribute the material or use it for any profit-making activity or commercial gain
- You may freely distribute the URL identifying the publication in the public portal

If you believe that this document breaches copyright please contact us providing details, and we will remove access to the work immediately and investigate your claim.



PVNET final report

PV integration studies

Guangya Yang, Søren Bækhøj Kjær, Kenn H. B. Frederiksen, Hans Henrik Ipsen, Rasmus Høyrup Refshauge

Contents

1.1	PROJECT DETAILS	3
1.2	SHORT DESCRIPTION OF PROJECT OBJECTIVE AND RESULTS	3
1.3	EXECUTIVE SUMMARY	4
1.4	PROJECT OBJECTIVES	5
	WPO SYSTEM ARCHITECTURE AND COMMUNICATION	6
	WP1 PV SYSTEM OPERATION STUDIES	7
	WP2 DYNAMIC ANALYSIS AND STABILITY SUPPORT	8
	WP3 TESTING AND EXPERIMENTAL SETUP	9
	WP4 DEMONSTRATION AND SOLUTION EVALUATION	10
1.5	PROJECT RESULTS AND DISSEMINATION OF RESULTS	14
1.5.1	VOLTAGE CHARACTERISTICS AT LV NETWORKS	15
1.5.2	GRID IMPEDANCE MODELLING	17
1.5.3	SOLAR PV SYSTEM AND ITS CONTROL FUNCTIONALITY	18
1.5.4	VOLTAGE RISE CONTROL VIA ACTIVE POWER	20
1.5.5	VOLTAGE CONTROL VIA REACTIVE POWER	24
1.5.6	ACTIVE POWER CONTROL CASE STUDY	24
1.5.7	REACTIVE POWER CONTROL CASE STUDY	26
1.5.8	SUMMARY OF VOLTAGE RISE CONTROL METHODS	33
1.5.9	TRANSFORMER LOADING WITH RESPECT TO PV PENETRATION	34
1.5.10	COMMUNICATION OF PV INVERTERS	36
1.6	UTILIZATION OF PROJECT RESULTS	37
1.7	PROJECT CONCLUSION AND PERSPECTIVE	37
2.	REFERENCES	43

1.1 Project details

Project title	Application of Smart Grid in Photovoltaic Systems – PVNET.dk
Project identification (program abbrev. and file)	ForskEL 10698
Name of the programme which has funded the project	ForskEL
Project managing company/institution (name and address)	Danfoss Solar Inverters Technical University of Denmark
Project partners	Danfoss Solar Inverters Technical University of Denmark Energimidt Bornholms Energi & Forsyning
CVR (central business register)	26843626 (DSI), 30060946 (DTU)
Date for submission	31 August 2016

1.2 Short description of project objective and results

The motivation of the project is to study how to increase the penetration level of solar PV systems into the current Danish distribution network. With exploitation of the state of the art of converter grid management functions, the project also studies the effects and feasibility of implementation in real distribution network. This is done by examining qualitatively and quantitatively different types of grid voltage control functions, applying inverter communication functionalities and introducing new ancillary services that can be provided by the solar photovoltaic (solar PV) systems.

The project contributes to higher deployment of solar PV plants into the current distribution grids, in particular residential grids, to postpone or avoid inconvenience to the grid or provide positive support to the operation. The impact and benefits of solar PV systems are more disclosed to both the operators and the public. The research can provide valuable analysis, solar PV data, testing facilities, and hardware platform in respect to the upper mentioned topics enabling a smooth integration of solar PV systems in networks. The practices in the project can be used as a sample to the grids who are ambitious in solar PV deployment, and would like to actively integrate solar PV systems into operation, taking advantage of the inverter technology which could help grid stability and management.

1.3 Executive summary

As traditional fossil-fuelled energy has drawbacks of greenhouse gas emission and air pollution that imposes on the global environment, the necessity of using new forms of generation has been realised and confirmed. In 2007, EU commission set the '20-20-20' targets which defines the goal of 20% EU energy consumption coming from renewable resources in 2020. This high level of renewable portfolio standard, and the cost reduction of renewable energy technologies are driving the renewable energy development. As a reliable source, energy from solar photovoltaics (solar PVs) is able to provide a significant share of electricity demand where a steep growth of application has been seen and will likely take place in the near future.

The potential impacts from solar PV on the operation of the electricity grid, especially distribution grids, must be investigated for further adoption. The existing grid has seen the growth of rapid demand increase in the last decade, and will be further populated by the new forms of renewable resources, such as rooftop solar PV plants. Traditionally the grid capacity and security are mainly reinforced by constructing new lines, however, it is restricted by economic and regulatory issues. To mitigate the grid impact from renewable resources meanwhile fulfil the high standard renewable goal, current initiatives on smart grid technologies may be an alternative.

The project lasted for more than 5 years therefore there are many activities in relation to solar PV integration were implemented. The main efforts of the project can be summarised into the following,

1. Grid impact study of solar PV systems focusing on the grid voltage impact, which is seen as a key limiting factor in weak low voltage grids;
2. Exploiting the grid management functions of solar PV inverters to verify the effectiveness of voltage control;
3. Explore the potential combination of solar PV with other technologies, especially storage devices, to enhance the distribution grid controllability;
4. Utilize the communication capability of solar PV inverters to broaden the monitoring system of distribution grid operator;

The first three items form the main body of research activities while the last bullet is on demonstration.

The activities in PVNET.dk project cannot survive alone without support from other smart grid projects that take place meantime. For example, PV Island Bornholm (PVIB) project [1], where the objective is to roll out solar PV systems on the island of Bornholm to reach about 10% solar PV power (of the peak load) in the island, provides PVNET the access to the solar PV plants in Bornholm for demonstration purposes. EcoGrid EU project [2], is a large scale EU project which set to study and demonstrate market based control for demand side management. Similar project as PVNET in the EU scale is MetaPV [3], which shows how solar PV can support the grid actively on a large scale in historically grown distribution networks.

The consortium is formed by:

- Centre for Electric Power and Energy, Technical University of Denmark (DTU);

- Danfoss Solar Inverters (DSI);
- EnergiMidt A/S (EMDT)
- Bornholms Energi & Forsyning A/S (BEF)

The key contributions and findings of the project are,

- Voltage control functions from solar PV inverters can help the voltage quality of the LV grid especially at the end of the feeder.
- For providing the grid services, there is a clear improvement when the control settings are optimized;
- Residential inverter measurements can be used as additional inputs for grid monitoring, however communication protocols are not fully in place, and the need for this can be more materialised for the attention of distribution grid operators;
- The need and potential of combining with storage technologies is seen as key to enable very high level of penetration of the solar energy.
- The recent Danfoss MLX solar PV inverter includes many new ancillary functions, developed during the PVNET project.

1.4 Project objectives

The initial project description starts from the motivation of study the full impact of solar PV systems in a modern grid, with all different kinds of issues including power balance, grid modelling and stability analysis [4],

- Prototype system

Carry out the modelling of prototype distribution systems/feeders with high penetration of solar PVs as well as other different types of distributed energy resources, to support the steady-state and dynamic study of system behaviours under regulated and deregulated environment.

- Grid operation studies

Study the operation impacts of solar PVs on the distribution and low voltage grids, without and with the presence of other renewable resources and demand, e.g. Electric vehicles, under different generation/load scenarios, both on the balancing issue includes the balance of power and energy based on solar PVs penetration levels, and planning issues.

- Stability impact

Study the dynamic behaviour both of the solar PVs power systems and the grid impact from solar PVs, the interactions among solar PVs and thermal units, and other distributed energy resources by exploitation of the state-of-the-art inverter technology to support the system stability on different stability issues.

All the studies serve the common objective of the project that is to explore the limit of the current grid for solar PV energy adoption, and investigate how the functions of inverter itself can help with the process, and the potential of extending the ser-

ices to a larger level. The objective is achieved through the five work packages that are summarised in the following Figure 1,

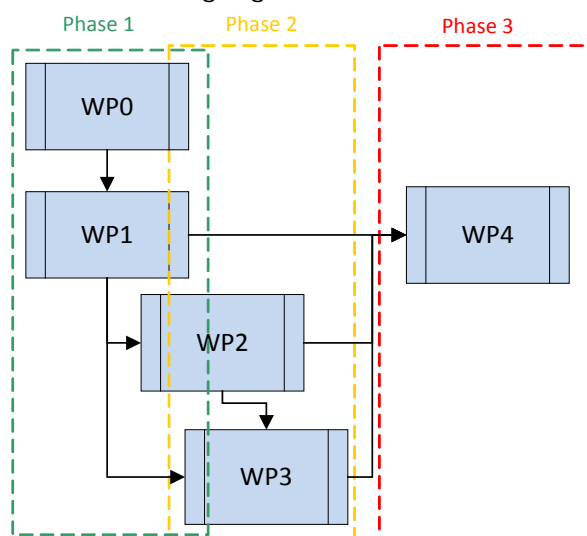

Figure 1. Illustration of the relations between Suggested work packages

WPO System Architecture and Communication

This work package was not initially planned however found to be extreme important to the project. The work package was set out to find out what could be the need of communication capability of inverters in the future operation. Different stakeholders were contacted when designing the system architecture and communication standards to ensure compatibility to the EcoGrid EU project.

The project come up with the following architecture that eventually lead to a solar PV virtual power plant (VPP),

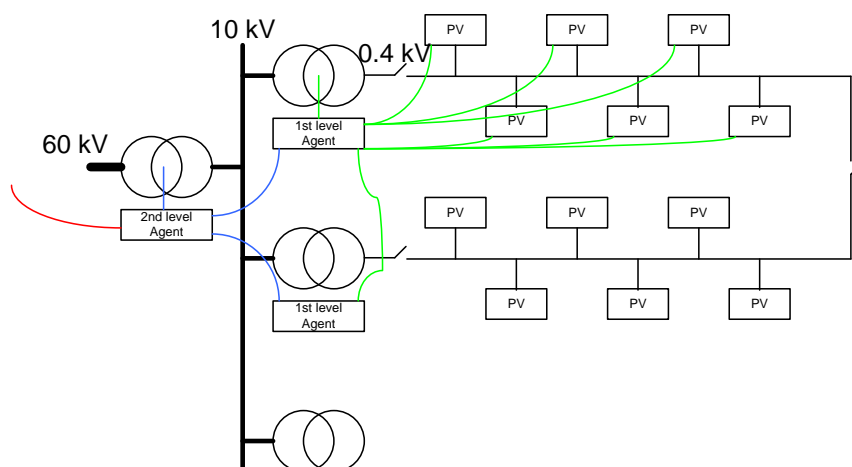

Figure 2. Assumed system layout, where each house/home has up to a few solar PV inverters. The PV systems are controlled by a local agent, 1st level agent, which communicates with the neighboring agents in case of a ring-network and also communicates with the 2nd level agent.

Such architecture is from commercialization point of view. By the time of discussion (2012-2013), a commonly agreed communication and information model for solar

PV inverters were far from convergence. From the project point of view, there are two threads to be followed

1. For demonstration purposes, since there is no commercially available solution, therefore to implement such system, a viable solution is to use the current communication capability of DSI inverters and develop a communication interface for the inverter, so that the data from inverters can be polled from external command through the firewall. This task is taken by DTU;
2. From the commercialization point of view, DSI continues to search for commercially available communication and information model (eventually Sunspec) and develop the inverter control manager (acting as agent in Figure 2).

The communication interface developed by DTU will be rolled out in industrial PCs which is installed next to the solar PV inverters. The lessons learnt from the WP and demonstration includes,

1. To communicate with the inverter in a local network from world wide web needs to breach the cyber security of the local network, which can be a big obstacle;
2. Customer contacts are important in implementing new technologies into the existing solar PV plants;
3. Agreements between the solar PV plant owners and the project need to be first in place for the project to have the access to the solar PV inverters;
4. The demonstration site was planned in the area with high solar PV penetrations, however, such place may not have DSI inverters;

The project eventually overcome all the issues to have the demonstration in place in real system, though after much longer time than expected.

WP1 PV System Operation Studies

WP1 aims at carrying out studies in the current grid and providing technical inputs and suggestions for the solar PV integration towards large share of solar PVs in the system with the presence of the other distributed energy resources. In the project result, various work was carried out in this work package on different aspects of solar PV systems. Details can be further sought in the dissemination results. In this report, the main contribution to this work package can be summarized into four main topics,

1. Voltage rise mitigation for solar PV systems;
2. Design and cooperation of solar PV and storage systems;
3. Exploitation of solar PV inverter ancillary services;
4. Hosting capacity of solar PV in distribution grids;

All the studies in the project are based on the energy system of BEF, which is given in Figure 3. The island of Bornholm is situated at the south of Sweden with 28 000 customers (of the grid company, not inhabitants). The total yearly consumption is about 268 GWh with 55 MW peak load. The network has a voltage level of 60/10/0.4 kV with multiple substations. There is a sea cable connected to Sweden through a 60/132 kV transformer, which enables the system operating in either

interconnected or island mode. The island has a high share of wind with 30 MW installed capacity, and are equipped with nearly 7.9 MW solar PV power currently. This makes the island attractive for renewable energy and smart grid studies and demonstration. PVNET.dk project exploits the advantage by both study and demonstration.

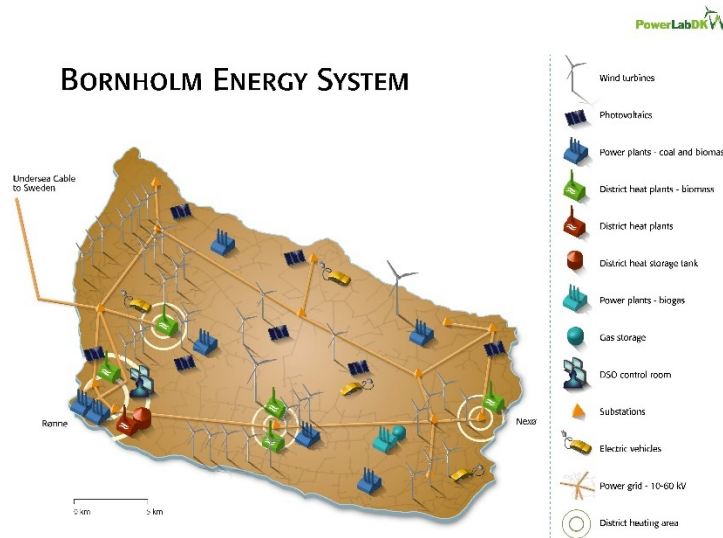

Figure 3. Bornholm energy system

Among others the combination of solar PVs and storage is seen as the most effective way for solar PVs integration, as the presence of storage devices significantly enhance the flexibility and efficiency of solar PVs operation. The storage can be possibly stationary batteries, electric vehicles, or heating facilities. A coordinated control among the solar PVs and other energy resources with different types of storage devices are necessary which is seen as an essential task for grid integration.

WP2 Dynamic Analysis and Stability Support

WP2 aims to provide a prototype model of distribution grid with solar PV systems as well as other distributed energy resources, and apply to dynamic study of the Bornholm system with high solar PV penetration.

As the research activities starts towards the distribution grid development, initiatives have been taken to develop a generic distribution grid model on the low voltage (LV) and/or medium voltage levels, as to a). simplify and generalise the studies performed, b). avoid disclosing secrecy information from distribution operators, c). streamline the results. In this project, dependent on different voltage levels, the prototyping task is broken down into the following three parts,

1. The highest voltage level of distribution grid. This is the 60 kV system with a circular topology, as shown in Figure 3. To preserve the fundamental network characteristics, no simplification is made on the topology. Parameters of transmission lines and transformers are changed slightly and used in the model for secrecy. As the main generation units (synchronous machines) located geographically close to each other, it is possible to aggregate them by

a single synchronous generator. The equivalent generator model is validated by applying symmetrical faults in the network.

2. For medium voltage level, the network contains thousands of components, including lines, transformers, and wind turbines. Since it is mostly radial operation, therefore the system is mainly finding the typical length and parameters of the feeder.
3. For the low voltage network level, one of the largest LV feeders in BEF with low LV transformer's capacity (relative to the rest) is found and used in the studies. Since solar PV issues so far take place in the residential network, therefore this system is used frequently in overall studies.

Dynamic study is focus on time series simulation of the voltage/frequency responses, small signal stability and volt/VAR compensation to the transmission grid. The study is based on Nordic32 system with a few synchronous power plants replaced by solar power plants with similar capacity.

WP3 Testing and Experimental Setup

The part of the work contributes to test the inverter functions in the lab and establish a solar PV integrating and testing lab in the PowerlabDK of DTU [5]. The work is also for developing and testing the communication interface before used in the BEF grid. The work comprises three parts,

1. Testing of inverter ancillary service functions

This part of work is testing the power control functions of inverters with respect to power functions,

- Reactive power control functions, a). reactive power set point, b). reactive power as a function of terminal voltage $Q(U)$, c). Power factor as a function active power $PF(P)$;
- Active power functions: a). Active power efficiency, b). Active power set point control, c). Active power output as a function of frequency, $P(f)$;

Figure 4 describes the main setup of the testing system in the PowerlabDK. The main power source is a 4-quadrant amplifier that can provide the required voltage signals for the response of inverters. A DC power supply is used that can provide the characteristics of solar panels for testing the MPPT tracking of the inverter. Labcells in the system serve as busbars that provide measurements and interconnection.

The solar PV system installed in the project situated close to PowerlabDK contains 3 DSI solar PV inverters with total capacity of 26 kW. The solar PV inverters are of type Triple Lynx Pro +, which has various grid interactive functions that can serve the need of the project.

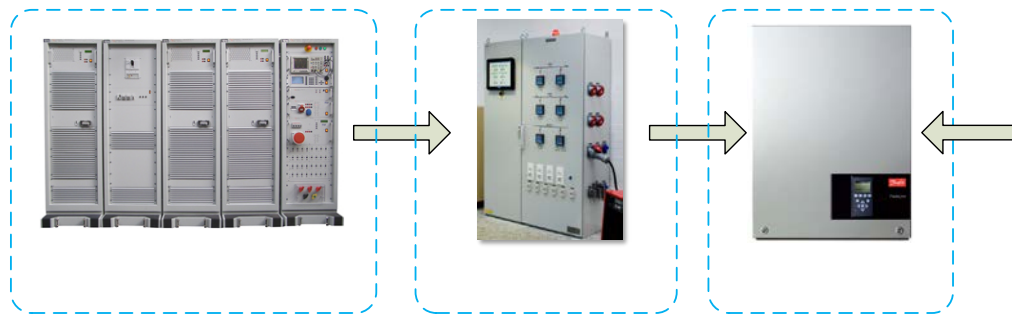

Figure 4. Testing system configuration

2. Installation of measurement system in BEF network

One of activities in the early phase of the project is to set up a measurement system in Bornholm at MV and LV levels using high quality measurement devices for monitoring the 3-phase voltages and currents from different renewable resources. The measurement unit has high sampling rate with waveform recording and GPS synchronisation capability, which can be used for both power quality monitoring and wide area control studies. The target is to roll out this type of measurement devices on Bornholm to all the steam generator units feeders, the 60/10KV stations feeders connected to wind farms and solar PV plants, the terminal of large solar PV plants, and the transmission line to Sweden. The measurements are transmitted near real time to a remote server located at DTU through Ethernet.

Eventually 10 ELSPEC metering devices [6] are installed in the system with high-resolution power quality measurements collected into the database at DTU PowerLab. The system has been running very well since it is in operation. The locations of the ELSPEC are in the wind power plant terminals, solar plant terminals, central connection links and power stations.

Besides the above two parts, a professional weather station for meteorological measurements is built within the project that provides inputs to solar PV forecasting tools.

WP4 Demonstration and Solution Evaluation

WP4 contributes to the implementation and evaluation of the methods and functions for PVs integration conforming to the EU goal. The work package contains the following steps,

1. Development of communication interface

The communication interface is developed on the protocol developed by DSI, which enables external software communicate with the inverter by obtaining the measurements and sending control signals. The communication interface will be installed in a small industrial PC, where the PC will be installed next to the inverter. The whole system architecture is given in Figure 5, which shows that

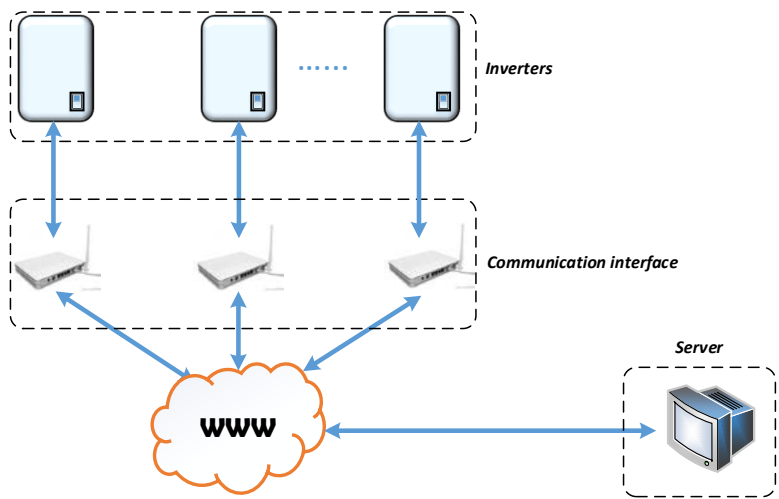

Figure 5. Communication system setup

The Danfoss inverter has an auxiliary capability for monitoring with time-stamped real/reactive power outputs, voltage/currents, frequency, etc. The measurements can be used for grid monitoring, and as inputs for solar forecasting.

- 2. Roll out the solution in agreed sites in BEF grid;

This part is non-technical part of the project, however requires most of the effort to be achieved.

Due to the ongoing PVIB phase 1-3 projects on Bornholm a large amount of distributed solar PV plants have been installed on the Island. The PVNET project tried to identify the spots in the BEF grid with very high penetration of solar PV. Even though that more than 5 MWp at that time was installed on Bornholm we found no place where the hosting capacity on a 0.4/10 kV transformer was much above 40%.

At the same time we were looking for areas with inverters from DSI since the software for control to be used in the project was made for DSI inverters. Due to changes in the net-metering support scheme during the project period and some tax issues related to private persons receiving subsidy for their solar PV systems the process of identifying grid nodes/areas with high amount of solar PV was delayed.

The table below displays shows the 20 transformer stations with the most solar PV installed. The hosting capacity is calculated as the relation between transformer power and installed solar PV power B/A [%].

STATION NR. (TRANSFORMER)	A [kVA _{TRANSFORMER}]	B [ΣkW _{PEAK}]	B/A [%]	PV INSTALLATIONS.
546	100	40,2	40,2	7
637	50	16	32	3
401	50	13,6	27,2	3

84	100	27,1	27,1	5
459	400	100	25	1
302	100	24,8	24,8	5
324	50	12	24	2
645	50	12	24	2
649	50	12	24	2
652	50	12	24	2
751	50	12	24	2
737	50	11	22	2
932	50	11	22	2
728	50	10,5	21	2
697	200	40,4	20,2	7
9	30	6	20	1
399	50	10	20	2
639	50	10	20	2
726	50	10	20	2
738	50	10	20	2

As showed in the table station 546 is the transformer with the highest amount of solar PV installed. The power ration is above 40%. The map of the area is given in Figure 6.



Figure 6. Location of PV plants at station 546.

In close collaboration with the PVIB project we investigated the possibility of installing more solar PV in this area with the potential to have a high percentage of solar PV installed. At the end we concluded that no more solar PV would be installed in this area within the time period of the PVNET project.

At the end we ended up using 2 solar PV systems that was installed at the Municipality of Bornholm. The systems have a total of 63 kWp installed and where grid connected through 6 inverters.

Plant information

- Rønne idrætshal
Torneværksvej 1, 3700 Rønne
3 x Danfoss 15 kW inverter
- Kildebakken
Kildesgårdsvej 19, 3770 Allinge
3 Danfoss 6kW inverter

The inverters were prepared for the control from DTU and access to the Municipality Ethernet and firewall was established after some challenges due to all the security setup. Depending on the application, future communication with key solar inverters for grid service purposes the options could be either through a direct fiber line to an inverter or through a RTU, while for general generation data collection then the task is to find a solution where the existing communication channel can be used, without affecting the security of the existing system

The system where tested in field and accessible from external for maintenance and error handling and we validated the effectiveness of the solution. The last part of the work that involves data quality checking from the server.

An envisaged future operation of residential solar PV systems from the project is illustrated in Figure 7. The solar PV system, together with storage devices, are coordinatively controlled by an intelligent smart house management system. The management system should be able to communicate with external operators, for example virtual power plants, distribution grid operator, or retailer, etc.

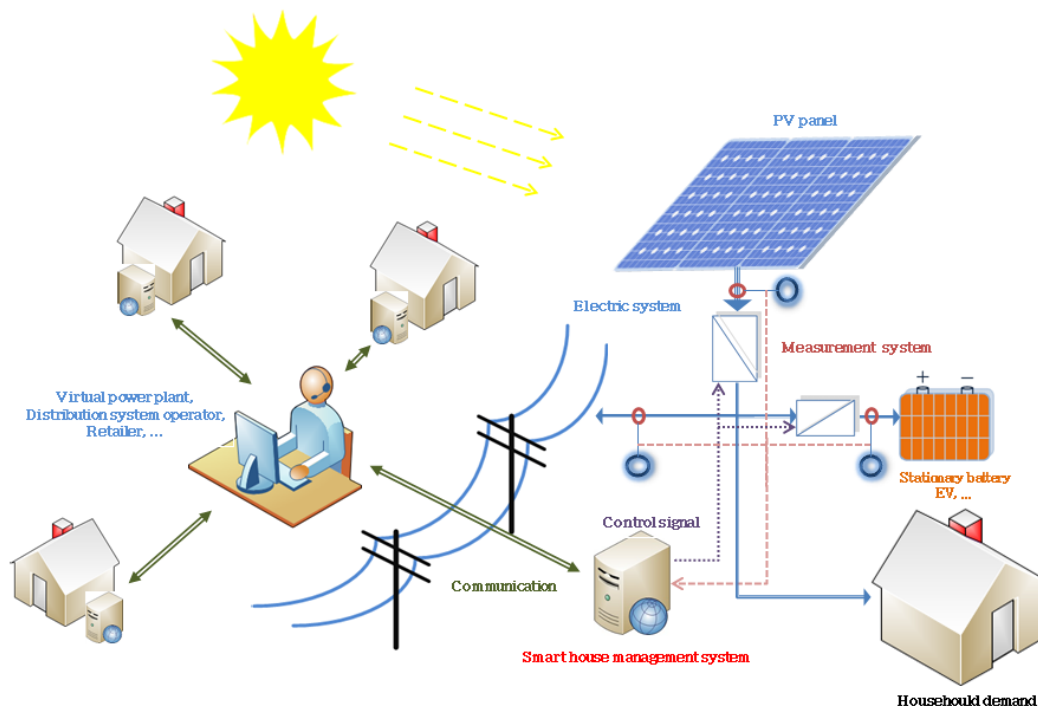

Figure 7. Envisaged future residential solar PV system operation

1.5 Project results and dissemination of results

Solar energy is the most important natural energy source to the world. The total solar energy absorbed by Earth's atmosphere, oceans and land masses is approximately 3850 000 exajoules (EJ) per year, which means one hour of the energy from the sun is nearly 10 times of the total world consumption in 2013 [7]. Solar photovoltaic power generation utilises solar panels comprised of a number of solar cells containing a photovoltaic material. Driven by the advancement of the generation technology and the ever decreasing technology cost, as well as the increase of electricity prices, a steep deployment of solar PV has been seen in recent years. The installation capacity worldwide increased nearly 10 times since 2009, and reached 227 GW in 2015 [8], which is after hydro and wind power, the third most important renewable energy source in terms of installed capacity [9]. According to recently published reports by the United Nations Environment Program (UNEP) in 2016, 56% of the investment in renewable energy worldwide flew into solar with continuous increase of new investment over the last 3 years [10].

In Denmark, though wind energy has been a primary focus area of the government, it has seen a fast deployment of solar PV in the last two years. With only total 16.7 MW installed by 2011, the capacity increases to 392 MW by the end of 2012, and approximately 800 MW today. The trend is foreseen to be continuous in the next few years, especially for the small- and medium-sized PV plants, given the ever increasing electricity price and decreasing technology cost.

Followed by solar PV adoption is grid integration. With high amount of solar PV installed, the variable solar PV outputs bring issues on the security of supply, especially due to the network constraints. A large part of the installation takes place in the low voltage (LV) residential areas, where the grids are not initially prepared for interconnecting large amount of generation units to feedback into the system. Issues such as voltage, congestion, efficiency, are emerging. Two main alternatives are available for those issues, network reinforcement and smart grid technologies. The solution of network reinforcement may involve large change of the network including the LV substations and cables, which are not a favoured solution by the utilities as to its cost and inflexibility, since conventional planning is based on the worst case scenario and the flexibility of the network operation is not modelled. On the contrary, the recent development in smart grid technologies, featured by the application of information and communications technology (ICT), advanced metering infrastructure, demand side management and virtual power plants, provides other possibilities to mitigate the solar PV impact. Several projects have been launched in EU in recent years to investigate these opportunities [11].

The ever increasing solar PV capacity naturally substitutes the traditional fossil-fuelled generation plants. Those traditional plants, besides supplying the demand, deliver various ancillary services to maintain the operational security. With the increasing of solar PV in the system, the operational services delivered by those traditional plants, consequently, are transferred to the new PV plants. On the other hand, thanks to the recent advancement of solar inverter technologies, solar PV is

able to provide system services by varying power outputs under different conditions.

The results given in the section focuses on important solar PV integration issues in the current distribution network.

- Voltage rise problem and mitigation control methods;
- Other grid impacts;

The content presented here represents a higher level abstraction of the work materialised in the project. Details can be sought from the dissemination list.

1.5.1 Voltage characteristics at LV networks

Voltage control is a critical issue for large scale PV integration in the LV grids. The resistivity of the residential LV grids makes the voltage control differs from high voltage (HV) transmission systems.

Considering a simple network as shown in Figure 8, ignoring the shunt capacitors of the system, in HV system, the magnitude of the resistance is much smaller than the reactance, whilst it is an opposite situation in LV grids. In Figure 8, considering receiving end voltage vector \vec{V}_T is at standard position, the expression of the voltage drop across the line is

$$\begin{aligned} \Delta V &= \dot{I}(R + jX) = \left(\frac{P + jQ}{V_T} \right)^* (R + jX) \\ &= \frac{PR + QX}{V_T} + j \frac{PX - QR}{V_T} \end{aligned} \quad (1)$$

In HV systems, as to the high X/R ratios, the voltage drop can be expressed by ignoring the resistance effect,

$$\Delta \dot{V} = \frac{QX}{V_T} + j \frac{PX}{V_T}, \text{ and } |\Delta \dot{V}| \approx \frac{QX}{V_T} \quad (2)$$

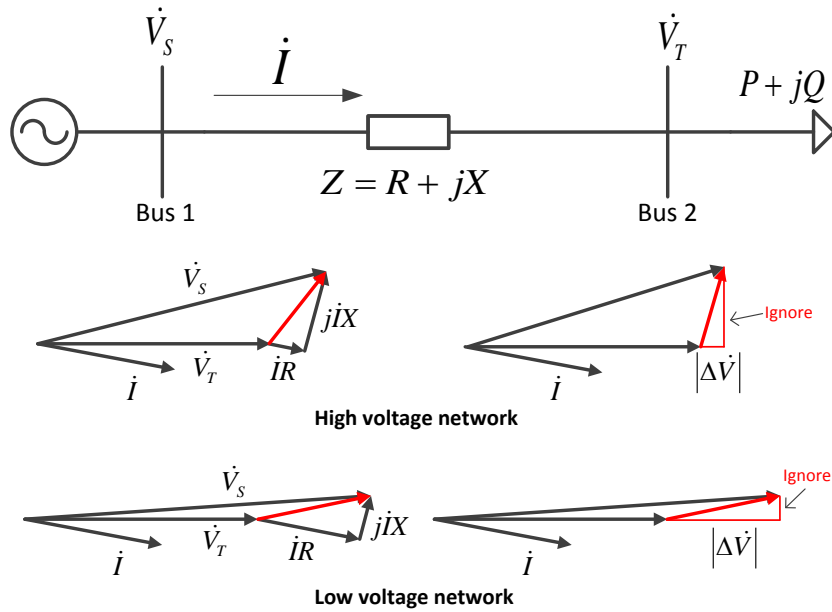

Figure 8. Comparing the voltage drop characteristics at HV transmission and LV grid due to X/R ratios

where $|\Delta \dot{V}|$ can be approximated by ignoring the effect of imaginary component PX/V_T . In LV systems, due to the lower X/R ratios, the effect of resistance is no longer negligible, and the assumptions taken for HV systems are no longer valid. This difference is also illustrated in Figure 8. Ignoring the imaginary part of (1), $|\Delta \dot{V}|$ in LV system may be approximated by

$$|\Delta \dot{V}| = \frac{PR + QX}{V_T} \quad (3)$$

The total derivative of $|\Delta \dot{V}|$ with respect to power transfer is

$$d|\Delta \dot{V}| = \frac{\partial |\Delta \dot{V}|}{\partial P} dP + \frac{\partial |\Delta \dot{V}|}{\partial Q} dQ = \frac{R}{V_T} dP + \frac{X}{V_T} dQ \quad (4)$$

From Eq. (4), it can be seen that an increment of active power transmission will automatically increase voltage difference; while by applying negative reactive power increment, this voltage magnitude difference may be reduced. For a system with solar PV installations, the solar PV inverter can be seen as the generator at the sending end in Figure 8 system with voltage \dot{V}_s , while the receiving end is the upstream system. If solar PV is injecting power into the system, ignoring the losses on the line, the power is the same seen at the receiving end, thus the discussion above explains exactly the voltage rise issue and the possible control strategies.

In general, the impedance in Figure 8 system can be viewed as Thevenin impedance seen from the solar PV inverter, together with the receiving end it represents the system side. To mitigate the voltage rise issue at the sending end, assuming Z and system side voltage \dot{V}_T constant, two ways can be seen from Eqs. (3)-(4): ① Reduce active power generation; ② Increase reactive power consumption.

The effectiveness of each method is however dependent on the X/R ratio of the Thevenin impedance, which can be seen from Eq. (4). The actual voltage difference across the line is dependent also on the actual values of X and R , as shown in Eq. (3). In order to design proper control strategy, it is of interest to study the Thevenin impedance of the distribution systems to design or select proper control methods.

1.5.2 Grid impedance modelling

A large portion of installed solar PVs is situated at residential grids. At this level, the system components include the LV feeder, solar PV plants, loads, and a LV transformer and upstream system. LV grid, including the LV transformer, may be modelled as detailed as possible to study the solar PV impact under both balanced and unbalanced situations.

The upstream system, since it usually has much larger capacity than the LV grid, can be simplified by Thevenin equivalent, where a method to obtain the impedance is Z -bus matrix, the inverse matrix of the admittance matrix. Given a system with n buses, the relation between the bus voltages $\dot{\mathbf{V}}$ and current injection $\dot{\mathbf{I}}$ is,

$$\begin{bmatrix} Z_{11} & \cdots & Z_{1i} & \cdots & Z_{1n} \\ \vdots & \ddots & \vdots & \ddots & \vdots \\ Z_{i1} & \cdots & Z_{ii} & \cdots & Z_{in} \\ \vdots & \ddots & \vdots & \ddots & \vdots \\ Z_{n1} & \cdots & Z_{ni} & \cdots & Z_{nn} \end{bmatrix} \begin{bmatrix} \dot{I}_1 \\ \vdots \\ \dot{I}_i \\ \vdots \\ \dot{I}_n \end{bmatrix} = \begin{bmatrix} \dot{V}_1 \\ \vdots \\ \dot{V}_i \\ \vdots \\ \dot{V}_n \end{bmatrix} \quad (5)$$

The diagonal element Z_{ii} represents the network impedance seen from the bus i . It is worth noting that compared to load flow calculations, the admittance matrix here should also consider the internal impedances of generators and loads if possible. This method can also be extended to unbalanced system analysis where each phase is calculated separately. As a static method, the accuracy is restrained due to the ever-changing system operating conditions.

Another method to obtain the Thevenin impedance is measurement based, where the system impedance is approximated by measuring the local voltage difference via varying load levels [12]. Though the method is easy to implement, it is often inapplicable to be applied to study large amount of solar PV installations in a distribution system due to the enormous number.

With an estimated grid impedance, a LV grid with solar PV system can be modelled as shown in Figure 9.

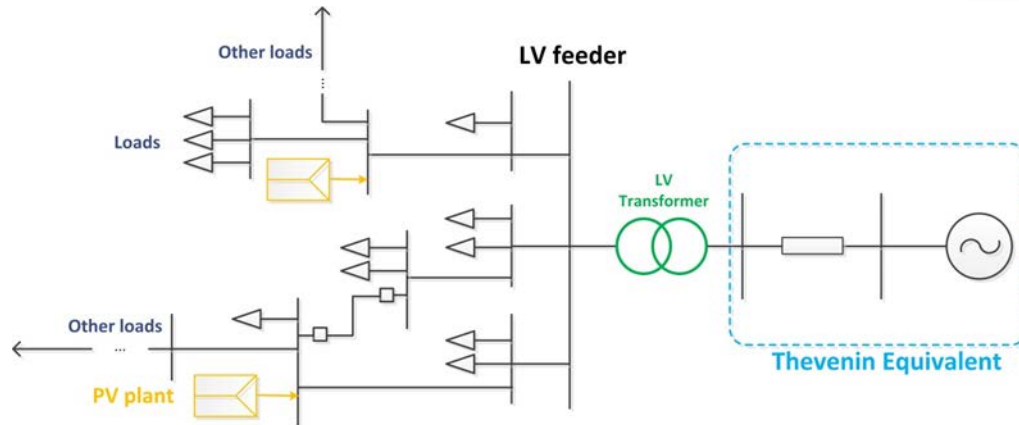

Figure 9. An example LV system with solar PV

1.5.3 Solar PV system and its control functionality

Dynamic model of solar PV plants are required in modelling the solar PV controls. Solar PV system can be seen as a controlled voltage source with variable impedances through which the current flowing out from the PV inverter is controlled (or a controlled power/current source in general terms). Different control strategies have been developed in solar PV inverters through controlling the current outputs. Depending on the objective of study, the operation of solar PV inverter can be either modelled in detail including the modelling of inner current loop, phase locker loop, pulse width modulation, and switching on/off of power electronics components such as IGBTs for EMT simulations; or simplified into a controlled current source in a system representing the active/reactive power characteristics for RMS simulations. Figure 10 shows an example structure of a standard solar PV system.

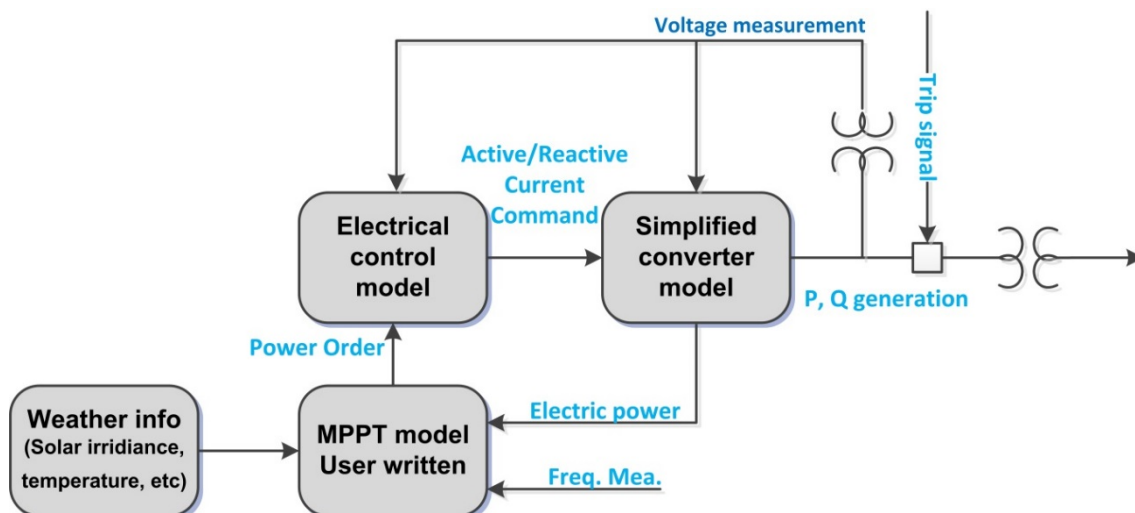

Figure 10. Example model structure of a solar PV system

In Figure 10, the electric control system includes the active and reactive power control loops. Current inverter manufacturing standards have defined the basic electric characteristics for grid connectivity that inverters are capable of [12] [13] [14]. The grid connection requirements are further elaborated on the basis of inverter control functionality by different countries. For active power control, a key requirement is

the power/frequency responses, where inverters are required to reduce their production when the system frequency is over a threshold. As an example, BDEW requires PV inverter to reduce the power output at a rate of 40%/Hz when the frequency is between 50.2Hz and 51.5Hz, while recover the production when the frequency back to 50.05Hz [15], as shown in Figure 11. Similar requirements are lately included in the Danish technical recommendations for solar PV (TF 3.2.1 and TF 3.2.2).

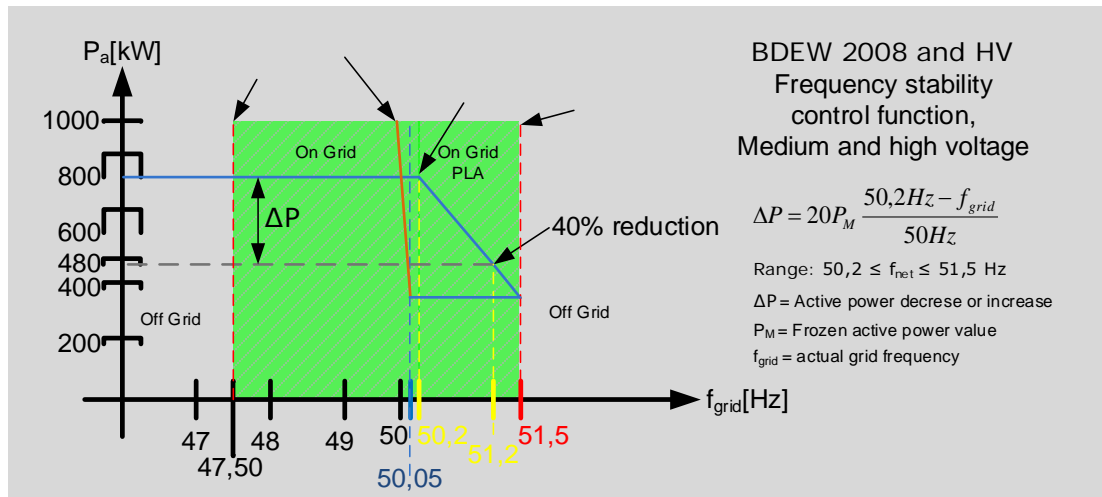

Figure 11. Frequency response requirements from PV inverters

Inverters above certain capacity are required to have reactive power capabilities [14] [16]. ENTSO-E newly redefines the network codes on the requirements of generation power plants, which indicates the PQ operational region, as the inner envelop shown in Figure 12.

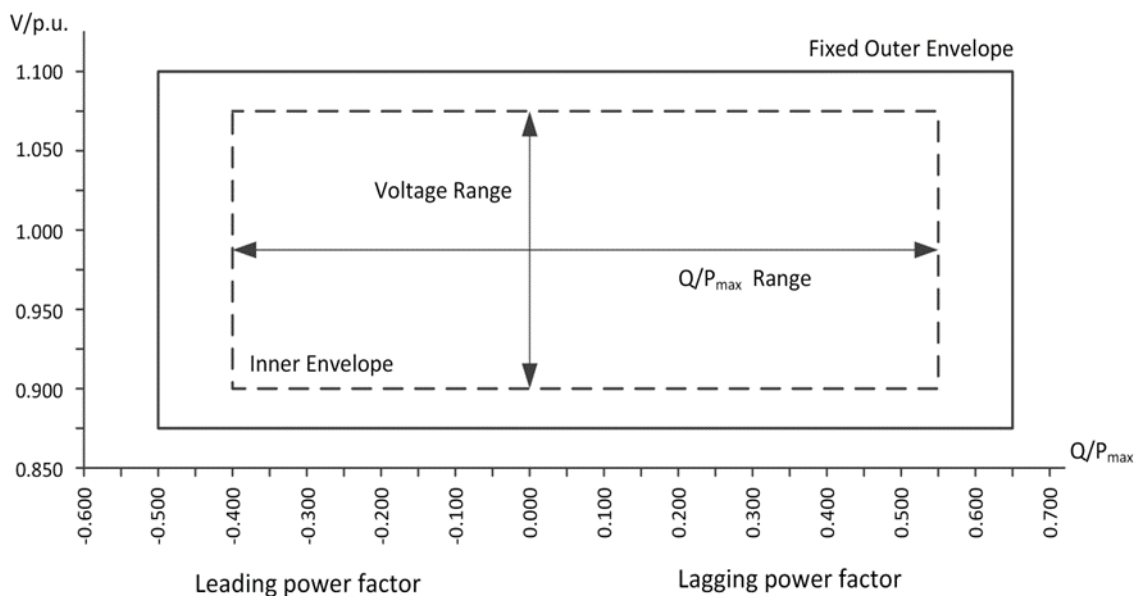

Figure 12. Operating PQ envelop

Inverters can have the following reactive power functions,

- Fixed reactive power setpoint;
- Fixed power factor setpoint;
- Power factor (PF) as a function of active power PF(P), or voltage PF(U);
- Reactive power as a function of voltage Q(U);

Inverters with small capacity may only have setpoint control capability, while larger units are usually capable of all the four control functions. Examples of PF(P) and Q(U) curves are shown in Figure 13. It is worth mentioning that the exact shape of the curve may be defined according to different situations. As shown in Figure 13 Q(U) curve, instead of a single droop, an additional point [U_x, Q_x] could be added to the lower part of the curve to differentiate the responses of the PV plants whose terminal voltages are close to the reference with the plants whose voltages are higher. This balances the reactive power contributions from the PV plants close to the LV transformers and the plants at the far end of the feeder.

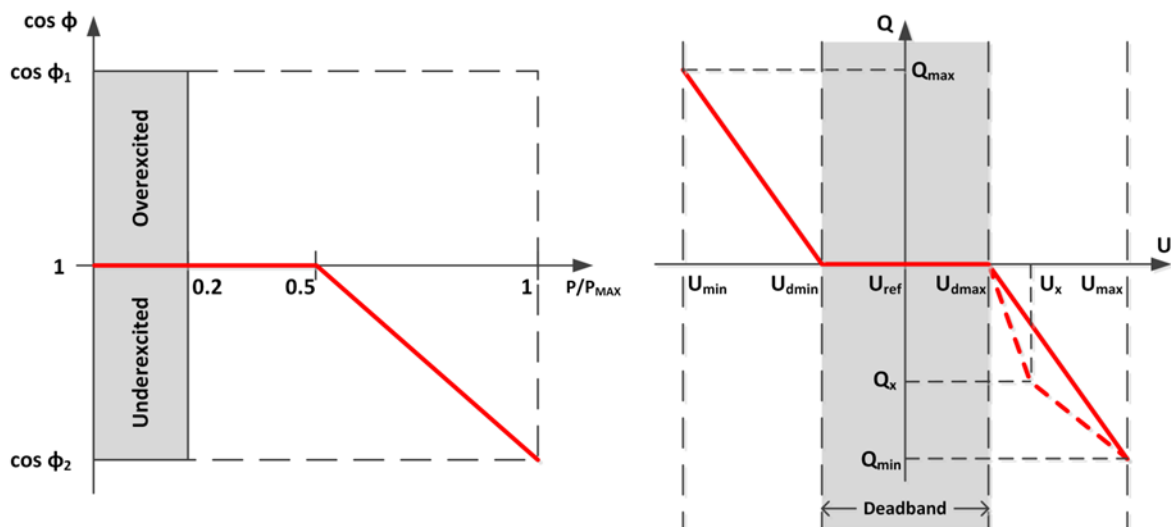

Figure 13. Example control curve for PF(P) and Q(U).

Grid connection requirements also define inverter characteristics under abnormal low voltage situations such as grid faults. For certain studies in protection and dynamic voltage support, this feature should also be included in the inverter electric control model.

During the project, a PF(U) control scheme was developed and implemented into an inverter and tested, see Figure 14.

1.5.4 Voltage rise control via active power

An obvious method to mitigate the voltage rise is via reducing the active power injection to the grid. As LV feeders usually have R/X ratio higher than 1 by Eq. (4), the active power method is more efficient than reactive power for voltage regulation purposes [17]. Among the various technologies proposed in literature, the basic ideas are two,

- 1) local consumption increase;
- 2) Solar PV power curtailment.

The local consumption can be adjusted through introduction of demand side management or components such as storage systems. As solar PV power curtailment is

not a favourable method for the loss of energy but also financially losses compared with other solutions, the discussion is hence focus on the first option.

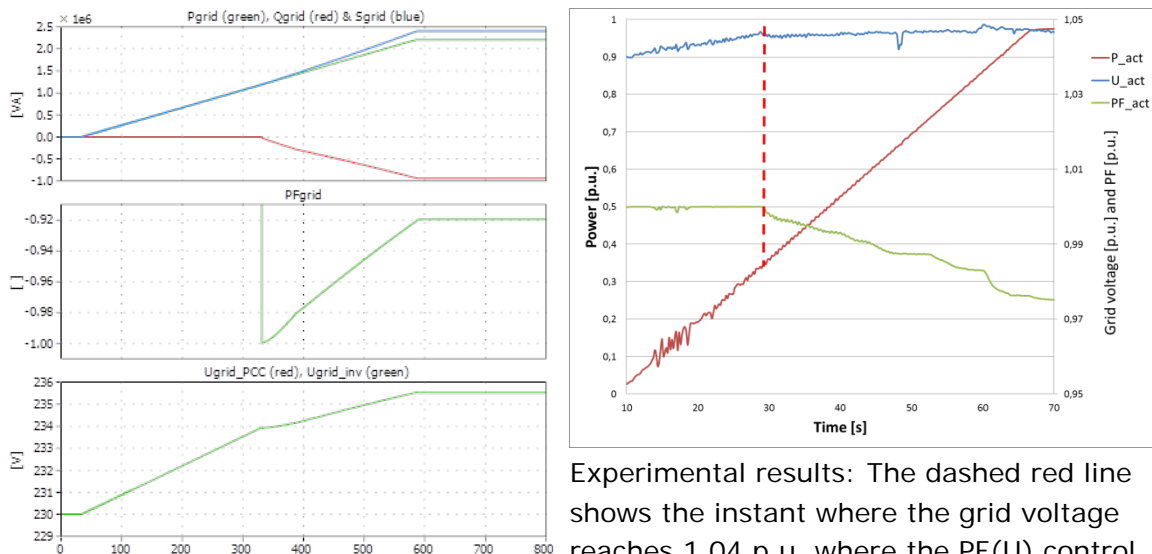

Simulated results: PF(U) based to VDE-AR-N 4105 setpoints. Pgrid = 2207 kW, PF = -0.9197, $\Delta u = 5.5$ V.

Experimental results: The dashed red line shows the instant where the grid voltage reaches 1.04 p.u. where the PF(U) control is activated.

Figure 14. Example control curve for PF(U) [18].

1.5.4.1 Solar PV with electrical energy storage systems

By applying electrical energy storage systems (EESS), solar PV plant output can be reduced through EESS charging during the peak production period, thereby keeping the LV feeder voltage stable. The energy stored by EESS can be used later to supply the demand. In addition, EESS can smooth out the PV power fluctuations and provide operational reserves to the system. Various commercial solutions as such have been developed in the market at the moment.

The implementation models of EESS at a LV feeder can be,

- 1) Decentralised storage systems installed together with PV plants. This mostly takes place at residential PV systems, and various home storage systems have been shown in the market;
- 2) Centralised storage station for the whole LV feeder. Such system could be owned by grid operator or mainly used for grid services;
- 3) Mix of above two possibilities.

Nevertheless, the main technical question of using EESS for voltage regulation is to determine the charging power for voltage regulation purposes. The project have found that the most efficient place of EESS is at the end of the feeder, where the required charging power of EESS is minimal.

A mathematical formulation using mixed-integer optimisation for charging power minimisation is

$$\begin{aligned}
 & \min \sum P_i \\
 & s.t. \\
 & |V_i| \leq |V_{i,max}| \\
 & 0 \leq P_i \leq \eta P_{i,max}, \eta \in \{0,1\}
 \end{aligned} \tag{6}$$

where P_i , V_i are the charging power and voltage of the feeder bus i where storage system interconnects. The integer variable makes the formulation applicable either for operation, determination of minimum charging power; or planning, determination of locations of storage systems. To check the voltage constraint, it usually needs solving nonlinear power flow equations to obtain voltage magnitudes. In the project, this constraint is simplified by a set of linear equations using first order Taylor expansion between voltage and power injection,

$$|V| = f(P, Q) \approx |V|_0 + \left(\frac{\partial |V|}{\partial P}, \frac{\partial |V|}{\partial Q} \right) \begin{pmatrix} \Delta P \\ \Delta Q \end{pmatrix} \tag{7}$$

where $|V|_0$ is the voltage magnitude at the base case. The first order derivatives can be obtained from inverse matrix of the last iteration Jacobian in Newton-Raphson load flow calculations.

With EESS the PV outputs can be reduced at a desired level. As seen from Figure 15, suppose a PV unit with the maximum output power of 4 kW with a perfect weather condition, to curtail the power output at 3350 W, theoretically the minimum EESS size is 1 kWh. To curtail the output power at 2170 W, the required EESS increases to 10 kWh. Technically, the energy requirement of storage systems is related to the PV generation, implementation models and operational strategy. Sizing of EESS involves optimisation across multiple time scales with different criteria, and different solutions can hereby result.

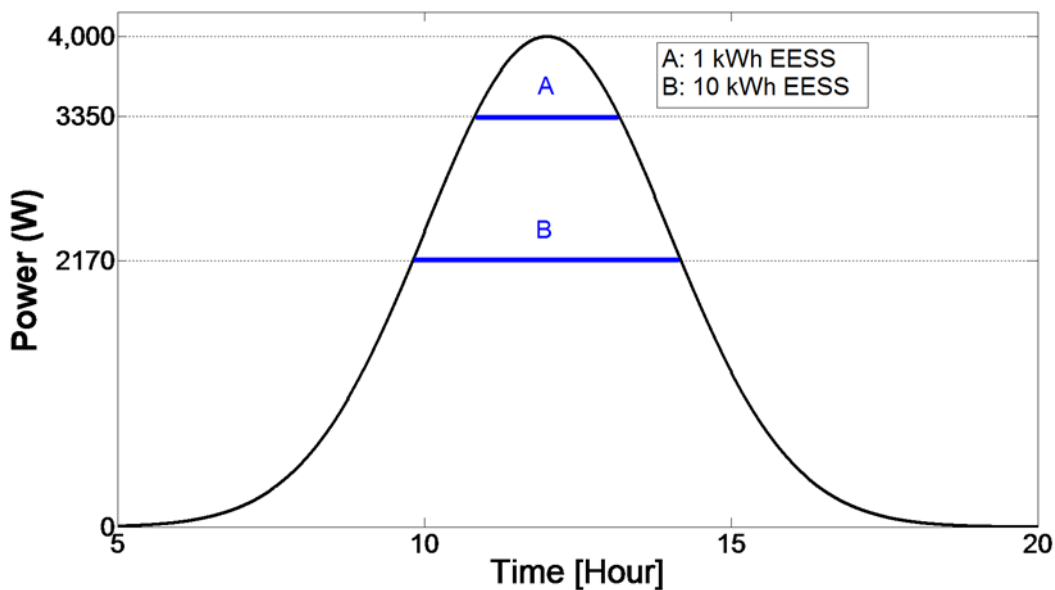

Figure 15. Energy requirements of EESS with PV systems.

1.5.4.2 Solar PV with electric vehicles

An emerging demand in LV grids is electric vehicles (EVs). EVs can work as a storage device when connected to the grid.

The project demonstrates that EV charging, which first may appear as an additional load to the grid, can be used as an effective storage solution. In grids with PV, EVs represent a unique opportunity, as not only they can locally consume part of the produced PV energy, yet this energy reduces the charging energy from the grid and gives additional travel range for EV drivers. For example, an average size EV with a 24 kWh battery, the charging process can show an additional demand of about 3.7 kW with a single-phase charging option. EV charging, with coordination to PV generation, can help to mitigate the voltage issues.

PV and EV have great potential to be incorporated in different ways. For house charging, a simple solution could be modulating the EV charging power by the grid voltage, where EVs apply more charging power when PV production and voltage are high while opposite when production and voltage are low. If the EV charging is regulated by aggregator, then more advanced control strategy should be applied through ICT infrastructure. For residential charging, a higher number of EVs is required to obtain equivalent voltage rise mitigation effects when the charging location is close to the LV transformer. On the contrary, smaller charging load is required with a station locates near the feeder end.

If we consider a public charging station, with the possibility to accommodate the parallel charging of several vehicles, this can be ideally seen as a grid-connected battery; the charging load due EV parallel charging can cope with high PV generation, by activation from a centralized position. The study performed in the project shows that a radial feeder can be able to accommodate more PV without the need of grid reinforcement, but only with coordinated EV charging.

However, the use of EV charging for voltage regulation corresponds to a particular type of active power management, which necessarily relies on EV availability and the uncertainty on solar irradiation. Such uncertainty can be mitigated by the number of EVs under a feeder, as a few driving pattern analysis shown in literature found that the availability of EVs is high during the mid-day when people started working, which is sync with the time when PVs are in high production. For individual cases, due to the orientation of PVs, the production curve can differ.

With the use of controlled charging, a new figure, the one of a local EV fleet operator, can make effective use of the EV load, by handling locally statistical information such as daily EV charging patterns and PV generation forecasts. Grid operator may buy the service from the fleet operator for voltage regulation to avoid voltage rise/reduction issues. How much exactly the grid should pay for such service is a question of cost/benefit analysis and proper defined requirements of the service.

1.5.5 Voltage control via reactive power

Reactive power is another option for voltage regulation. Unlike active power, reactive power method exploits the capability of inverters without need of additional devices for voltage regulation. Though may not as efficient as active power method at LV grids, it could be more in favour of the stakeholders as neither PV production curtailment nor additional investment is required. However, as additional reactive power could induce additional reactive current in the grid, additional grid losses may result especially at high PV penetration levels [19].

Inverters above certain size are capable to provide reactive power even when reach the nominal active power output [16]. The inverters can be set either individually by empirical approaches, or by certain coordination. Both cases are testified in the project. The characteristics of reactive power provision are defined by the selected control method and its parameter settings.

The setting of reactive power control can be dependent on the PV production and the resulted voltage. Considering the possible extra losses in the network as well as possible congestion issues, the objective of coordination can be a compromise of the three objectives,

$$\min f = c_1 (V_i - V_{ref})^2 + c_2 \sum P_{loss} + c_3 \sum (S_i - S_{i\max})^2 \quad (8)$$

where V_i and V_{ref} are the voltages at the i -th PV plant terminal and preferred voltage, respectively. V_{ref} can be set according to the LV transformer tap position, and usually is 1 pu. P_{loss} represents the total power losses in the system. S_i and $S_{i\max}$ represent the actual flow and the maximum flow on the i -th section of a LV feeder. c_1 , c_2 and c_3 are coefficients of each objective.

Subject to Eq. (8), the performance of different control settings should be evaluated under different PV production and load scenarios, and time series simulation or sequential load flow analysis may be required to obtain a general performance of the settings. The above formulation can be deployed to tune the parameter settings, while the setting that provides overall best performance should be selected. In implementation, by the above formula, a group of PV inverters can thus be coordinated and run together as a 'Solar Virtual Power Plant' to realise voltage regulation at a LV feeder, or even a larger distribution area.

1.5.6 Active power control case study

A comparison of using active and reactive power for voltage regulation is done using an example grid from with 33 households and 9 roof-mounted PVs, as shown in Figure 16. The results build on the work presented in [20]. Time series simulations are performed based on 1-year generation and load profiles, highlighting the need of voltage regulation in 98 days.

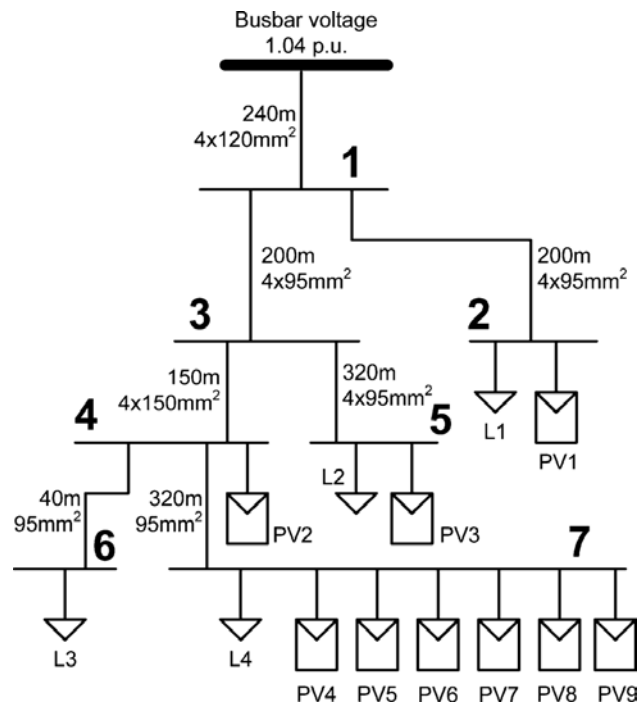

Figure 16. An example system used in study

Figure 17 shows the minimum required active power reduction at the different locations, related to the charging power from EESS or the number of EVs considering 3.7 as normal EV charging power. The results verify again that the most efficient place for voltage regulation is at the end of the LV feeder, where the least amount of storage (active) power is required.

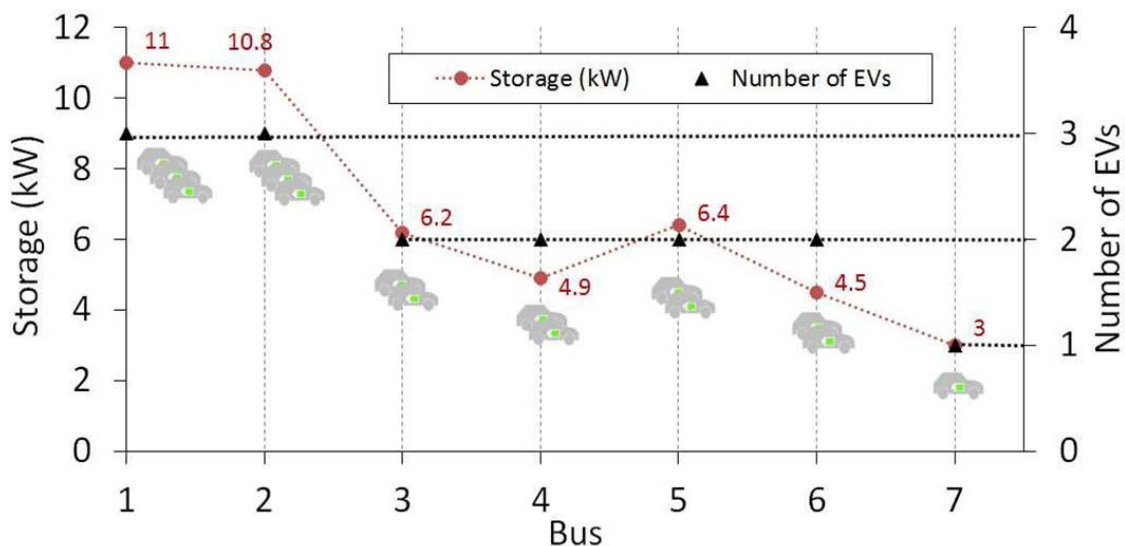

Figure 17. The required storage power and corresponding number of EVs.

The required active power in Figure 17 considers only one place at each time for voltage regulation. Therefore, the values represent the maximum power required at each bus. If more than one bus along the feeder are possible for supplying voltage regulation, the minimum required active power at each bus will be less the value given. The determination of the energy level of EESS varies from different opera-

tional strategies. In reality, planning of EESS will be a compromise between economic and technical considerations, while voltage regulation is one of the benefits obtainable from EESS.

For comparison, similar simulation is also performed using reactive power control to achieve the voltage regulation, as shown in Figure 18, where the least reactive power capacity is obtained at different locations. Similar as active power, the most efficient place for reactive power compensation is at the end of the feeder. Comparing to the active power results, it can be seen that the amount of required reactive power is approximately 3 times more than active power, which corresponds to the R/X ratio of the grid. Please remember, that modern solar PV inverters already offers the possibility of reactive power control for this purpose.

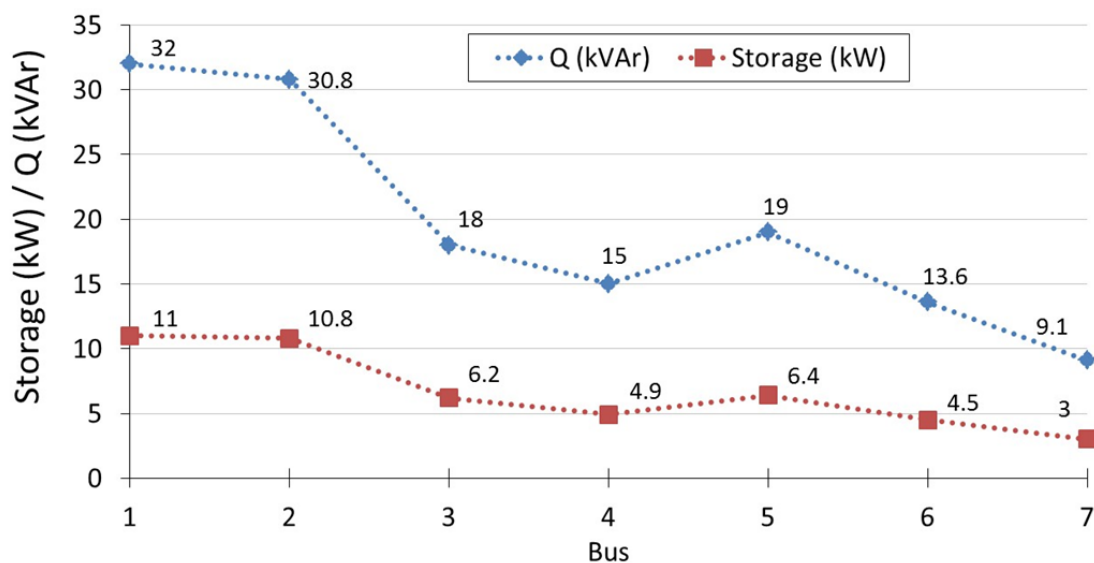

Figure 18. Comparing required active and reactive power for voltage control

1.5.7 Reactive power control case study

An example case is implemented on a LV grid from Danish island Bornholm. The grid contains 71 households with two LV feeders supplied by one MV/LV 100 kVA transformer.

The two feeders, feeder 1 & 2, contain 52 and 19 consumers respectively, with an interconnection cable in between. The interconnector enhances the reliability of the supply and opens under normal operation. The grid topology and households locations are shown in Figure 19.

The case studies include two parts. The first part of the study uses typical settings of PF(P) and Q(U) functions without any optimisation, where in the second part the parameters of PF(P) and Q(U) are optimised. Finally the results are compared. The first case study aims to compare the PF(P) and Q(U) methods in a general situation at different PV penetration levels with 1-year production and consumption data sets used in time-series simulations. The second study illustrates a simple coordination of reactive power control to achieve a set of optimal parameter values given typical

production and consumption values of the feeder. The two study results are not comparable as different datasets used, however it provides a general idea of how to choose different controls under different situations.

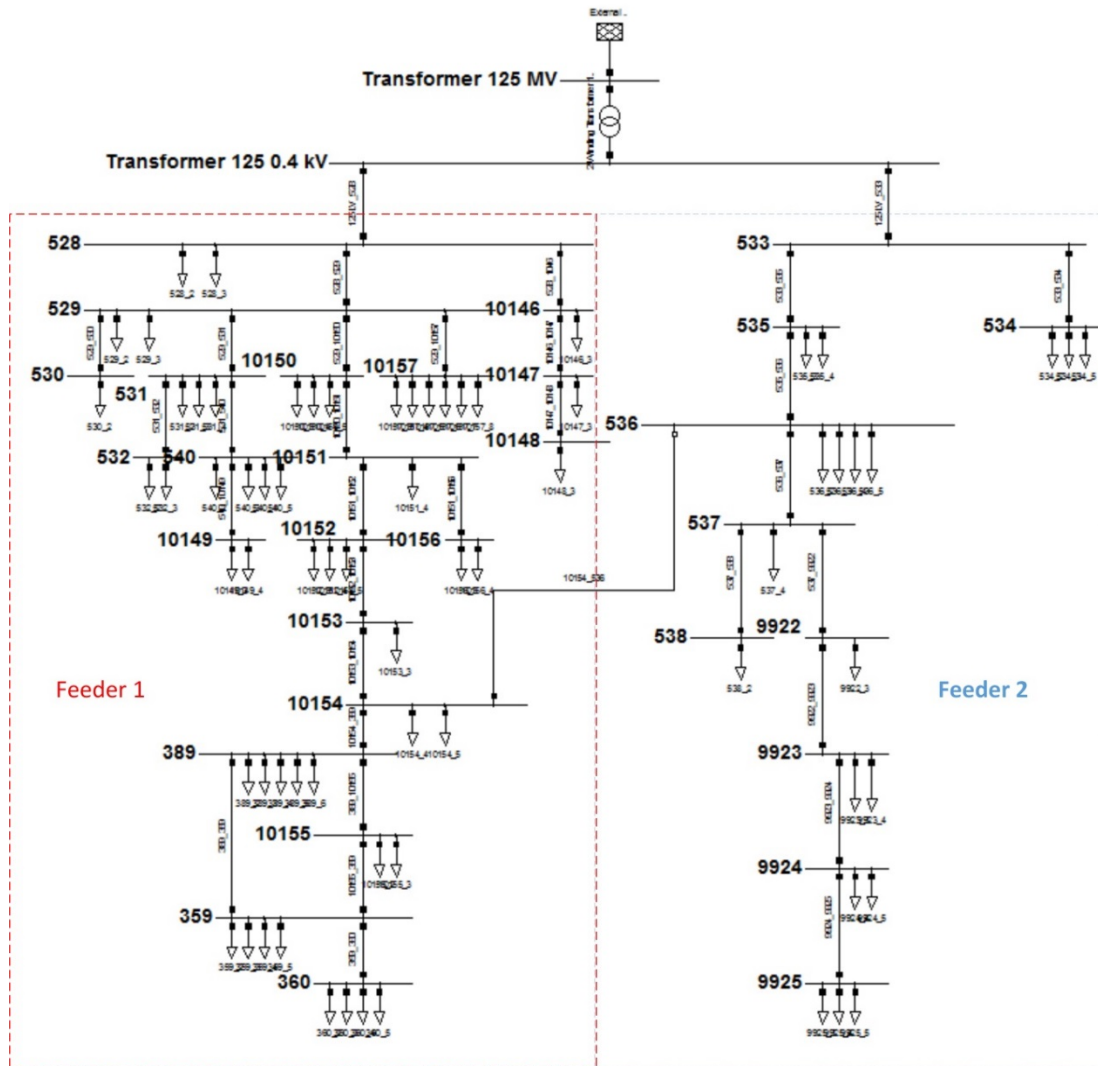

Figure 19. Testing system topology and load connections.

The definition of PV penetration used here is,

$$L_{PV} = \frac{S_{PV \text{ feeder}}}{n_{loads} S_r} \times 100\% \quad (9)$$

where $S_{PV \text{ feeder}}$ represents the installed PV power under the feeder, n_{loads} is the number of customers down the feeder, in this case is 71. S_r is an estimated maximum PV power at the feeder. In Denmark, a usual installation size for non-commercial residential users is around 5 kVA, therefore, by Eq. (9), 100% PV penetration means all the users in the grid have 5 kVA PV installed, corresponding to 355 kVA. The studied penetration levels range from 0 to 60% in step of 10%, corresponding to PV installation from 0 kVA to 3 kVA at each household.

1.5.7.1 Without coordination

The data for setting up time-series simulation include PV production and residential user consumption. The electrical energy consumption of a residential household in Denmark is obtained from a typical year at total energy consumption of 3.44 MWh. The PV generation is formulated considering the worst scenario, where all the houses are assuming inclining 45° south for most possible solar production. A typical production curve of 1 kWp PV is used as a reference to obtain the hourly production data for one year. The production curves are scaled to represent different penetration levels.

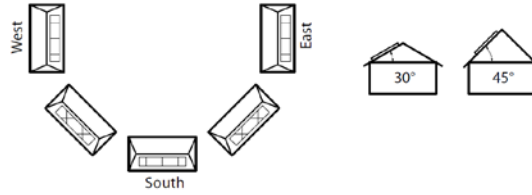

Figure 20. Orientation of house.

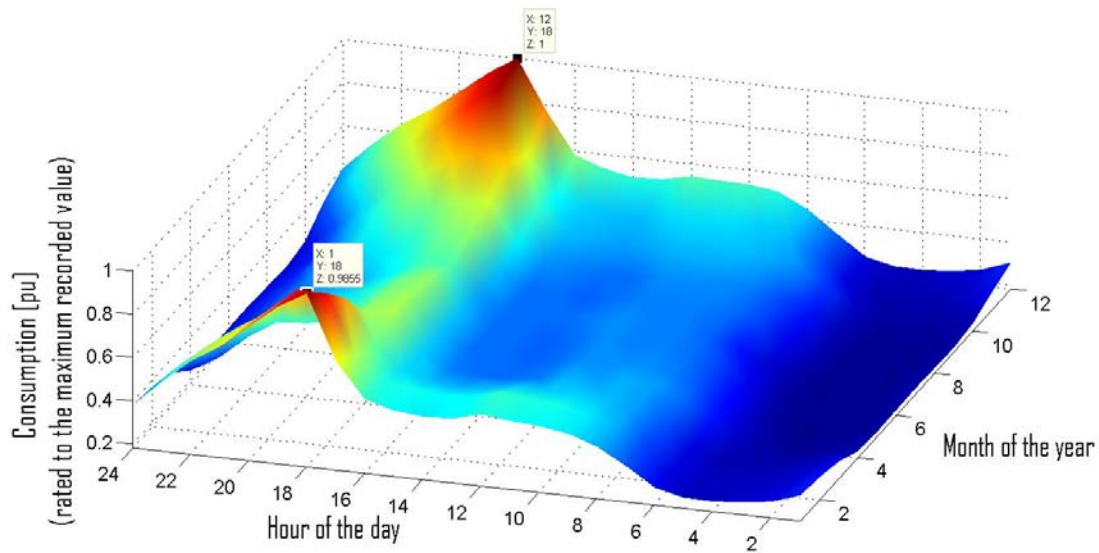

Figure 21. Electrical energy consumption over one year for a typical Danish residence.

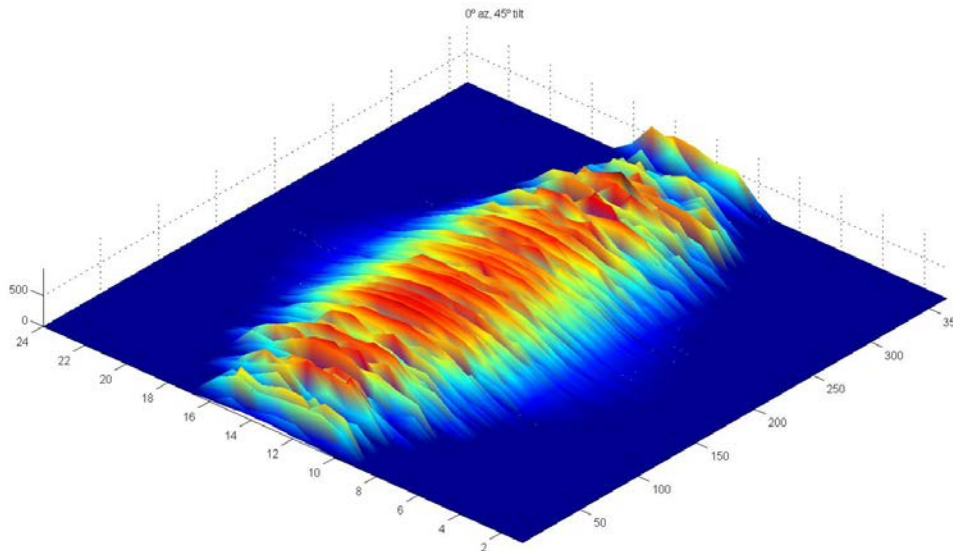

Figure 22. Yearly synthesized PV production data for Brædstrup, Denmark, of a 1 kWp PV plant

The parameters of reactive power control are listed in Table 1. Simulation results from the two types of controls are given from Figure 23-Figure 26. From Figure 23 and Figure 24, it can be found that feeder 1 is more likely to have voltage issue than feeder 2, and the PV penetration level given default PF(P) can maximally reach 30% to 35% percent considering all the households install same amount of PV. With Q(U) method, the voltage is better regulated and the penetration level can go up to 50% without any voltage problem. Apparently, the advantage of Q(U) over PF(P) comes from more reactive power contributions to the voltage regulation, and hence induce more system losses.

Reactive power control mode	Parameters according to Figure 13
PF(P)	$\cos \varphi_1 = 0, \cos \varphi_2 = 0.95$
Q(U)	$U_{dmin} = 0.98, U_{dmax} = 1.02, U_{ref} = 1$

Table 1. Reactive power control parameters

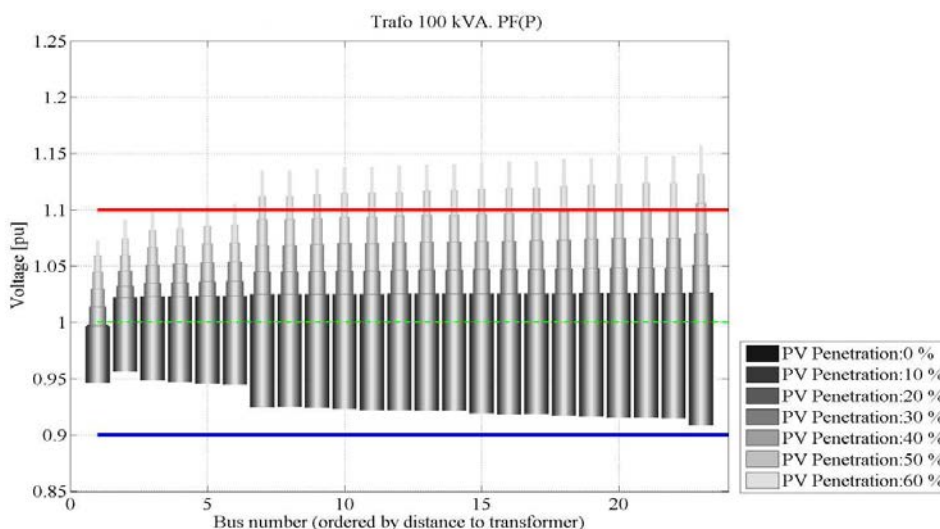

Figure 23. Maximum voltages at different levels of PV penetration along feeder 1 via PF(P).

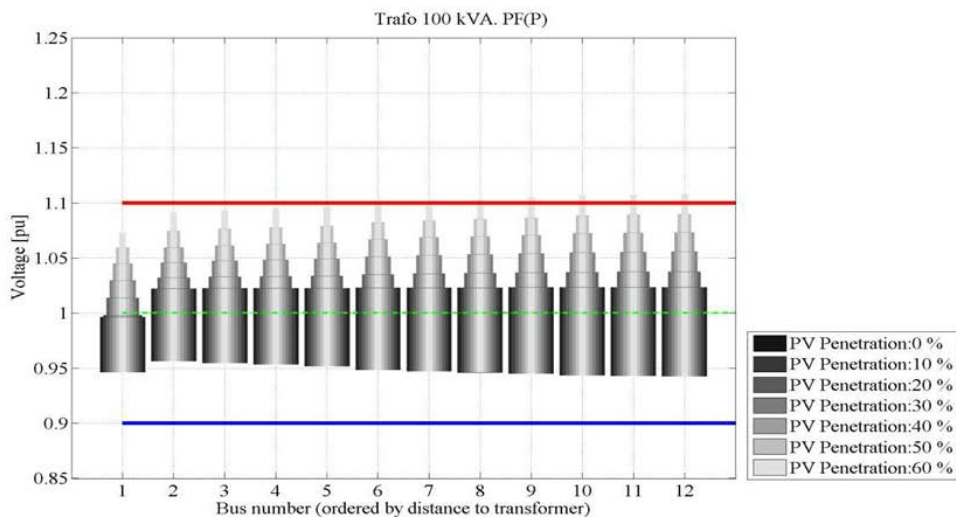

Figure 24. Maximum voltages at different levels of PV penetration along feeder 2 via PF(P).

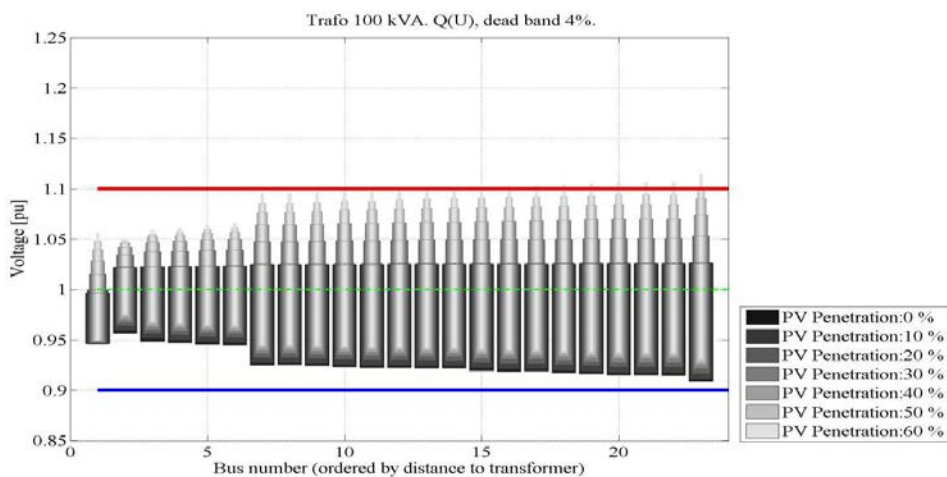

Figure 25. Maximum voltages at different levels of PV penetration along feeder 1 via Q(U).

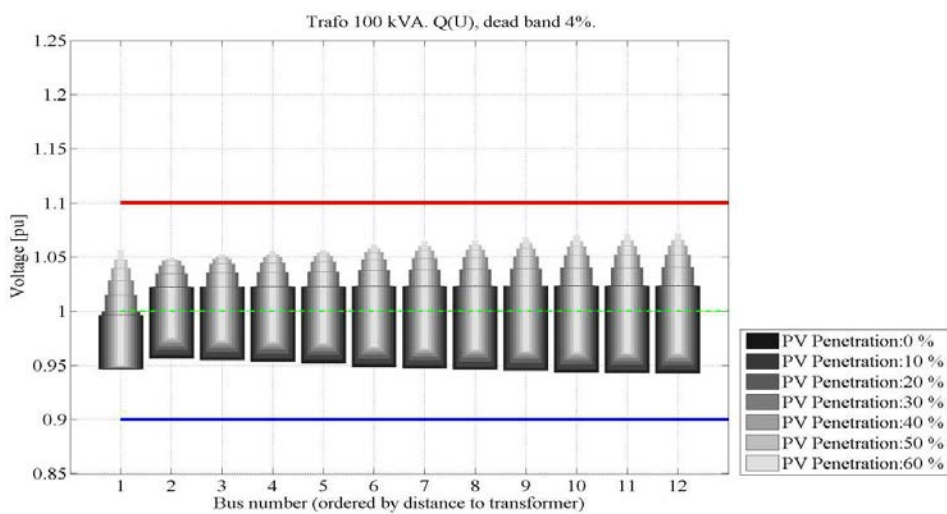

Figure 26. Maximum voltages of different levels of PV penetration along feeder 2 via Q(U).

A general conclusion can be, given low penetration of PV installations where voltage is not major concerns, PF(P) method can be more appropriate choice over Q(U). This is due to the fact that with low penetration of PVs, the voltage does not fluctuate much on the LV feeder, therefore the effectiveness of Q(U) is not as good as PF(P).

1.5.7.2 With coordination

To coordinate the control parameters according to Eq. (8), nonlinear optimisation technique is required to tune the parameters. In this work, the problem is solved via Genetic Algorithms (GA), where the parameters of the controllers are tuned based on the below objective function,

$$\min f = c_1 (V_i - V_{ref})^2 + c_2 \sum P_{loss} + \lambda_1 \Delta V^2 + \lambda_2 \Delta Q^2 + \lambda_3 \Delta S^2 \quad (10)$$

where the first and second items represent the voltage deviation and power losses respectively. The last three items penalise the over-limit of voltage, reactive power generation, and line flow. The optimisation variables for PF(P) and Q(U) are given in Table 2.

Reactive power control mode	Parameters according to Figure 13
PF(P)	$\cos \varphi_1, \cos \varphi_2$
Q(U)	$U_{dmin}, U_{dmax}, U_x, Q_x$

Table 2. Optimisation variables

As the voltage, power losses in Eq. (10) are instantaneous quantities, to evaluate the control parameter efficiency over a time period, certain procedure of evaluation is required,

Step 1. Import solar production and load scenarios performing time series simulations, export the results on bus voltages, power losses, line flows, reactive power outputs from solar plants, at a given time resolution;

Step 2. Find out the worst voltage value, and the calculate the accumulated energy loss over the simulation period;

Step 3. Evaluate the variable over limits by using the worst values during the simulation;

Step 4. Calculate the objective function;

Since the studies with coordination is done separately by different partners where the input solar PV data and consumption is not exactly the same. However the level of PV penetrations are defined in the same way which makes the increasing of PV installation have similar effects as previous case. The results from the coordinated case are listed in Table 3. The voltage profiles along the feeder are shown from Figure 27-Figure 30.

PV inst.	10%		20%		30%		40%		50%		60%	
	$\cos\phi(P)$	Q(U)	$\cos\phi(P)$	Q(U)	$\cos\phi(P)$	Q(U)	$\cos\phi(P)$	Q(U)	$\cos\phi(P)$	Q(U)	$\cos\phi(P)$	Q(U)

)))))))))
$\cos\phi_1$	0.986	0.974	0.961	0.960	0.964	0.961			
$\cos\phi_2$	-0.941	-0.923	-0.946	-0.941	-0.958	-0.944			
U_{\min}	0.96 1	0.96 0	0.97 9	0.96 0	0.96 1	0.96 2			
U_{\max}	1.02 1	1.02 1	1.02 1	1.02 0	1.02 0	1.02 1			
U_k	1.04 5	1.04 5	1.04 5	1.04 5	1.04 5	1.04 6			
Q_k	- 0.24 4	- 0.27 4	- 0.29 0	- 0.22 2	- 0.27 7	- 0.28 2			

Table 3. Optimisation results of the parameter values.

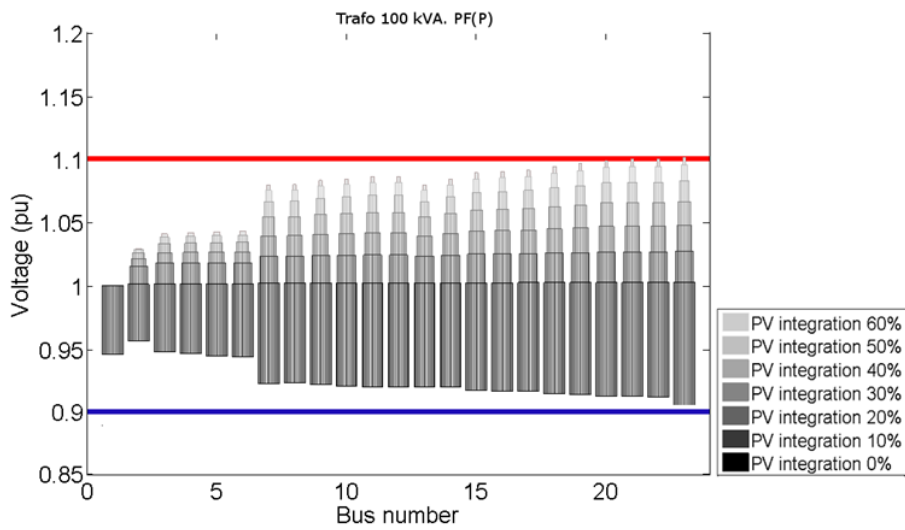

Figure 27. Maximum voltages at different levels of PV penetration along feeder 1 via PF(P).

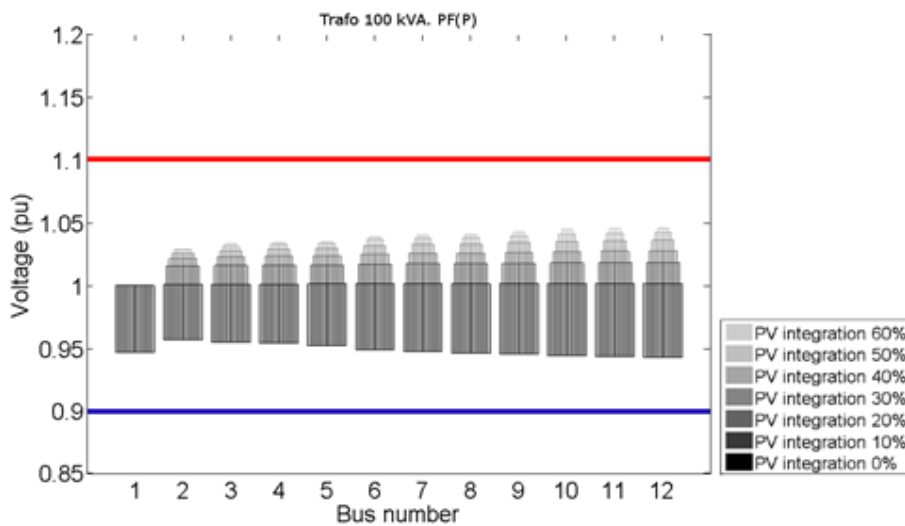

Figure 28. Maximum voltages at different levels of PV penetration along feeder 2 via PF(P).

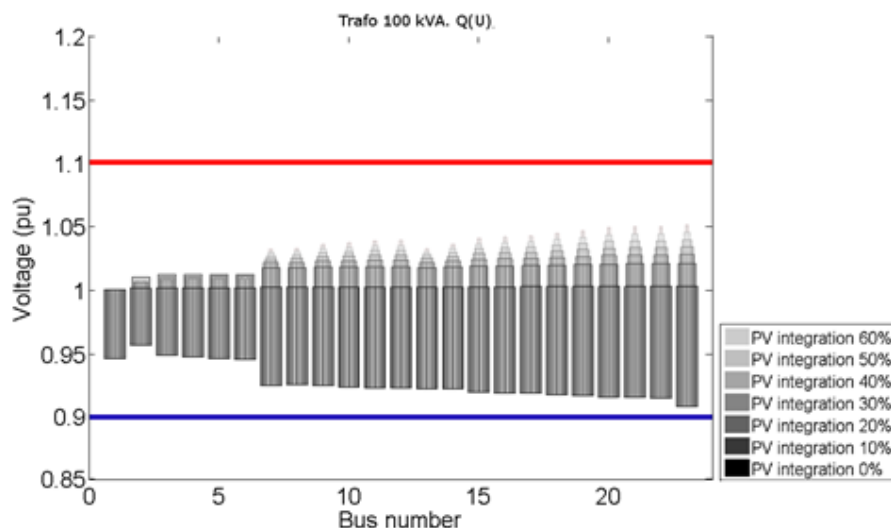

Figure 29. Maximum voltages at different levels of PV penetration along feeder 1 via Q(U).

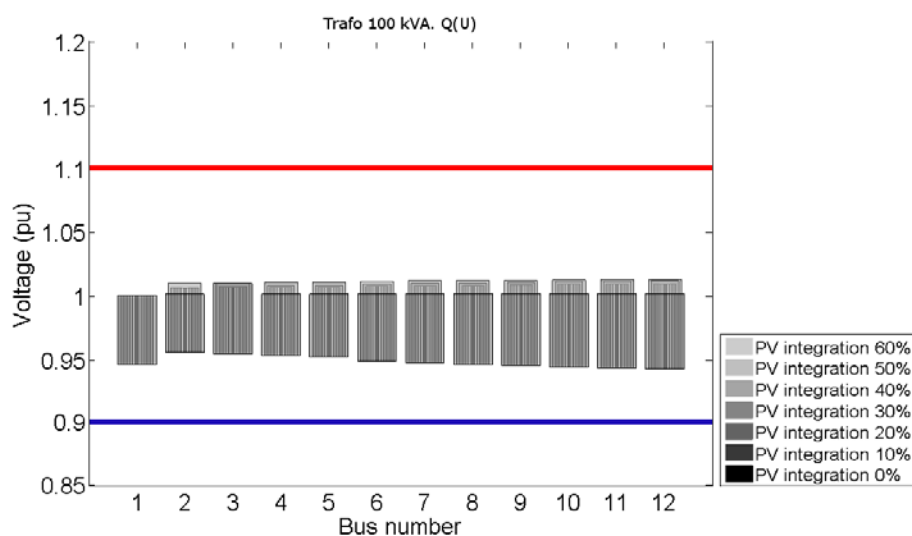

Figure 30. Maximum voltages at different levels of PV penetration along feeder 2 via Q(U).

Shown from Figure 27, with the coordination, the PF(P) method can merely control the voltages within the safety band when PV goes up to 60% penetration level. Q(U) method still outperforms the PF(P), which gives same effect as in the previous case without coordination.

As mentioned before, the results from the two cases are not fully one to one comparable, as to different assumptions and scenarios taken in the studies. However, in terms of the voltage rise issue, both cases comprehend a scenario in which PV generation is high and demand is low. It concludes that the coordination of reactive power control parameters can efficiently increase the PV penetration level than without coordination. This can be more an issue when the PV penetration level is up to a certain degree.

1.5.8 Summary of voltage rise control methods

Voltage control is one of the urgent issues in distributions system for solar PV integration. Many LV networks are designed decades ago, and were not prepared to accommodate the large amount of power flowing feeding into the grid.

It has to be mentioned that the discussed methods are originally designated to 3-phase systems, though the same concepts are also well applicable to single-phase distribution networks. However, more sophisticated controls can be developed based on the solutions discussions here. For example, it is not uncommon to see that overvoltage in a 3-phase LV system only occurs at one phase, instead of all phases, due to significant amount of single-phase PV systems installed. In that case, control should be designed to balance the usage of the three phases, instead of simply reacting upon an average voltage of the 3 phases.

1.5.9 Transformer loading with respect to PV penetration

The loading of transformer can be affected by the PV penetration level as well as the voltage control methods. Figure 31 illustrates a general trend of yearly transformer overloading with respect to the increasing PV penetration level. The increasing of transformer overloading shows nonlinear characteristics with respect to the PV penetration. At low penetration levels, the transformer loading situation will not be affected by the PV, which assigns with the design principles of the current grids. With increasing penetration levels, there could be a sharp increase of the transformer overloading due to amount of active power generation as well as increased reactive power consumed by the inverters. But this will not be an issues as long that the total power from the solar PV plants are below the nominal value of the transformer.

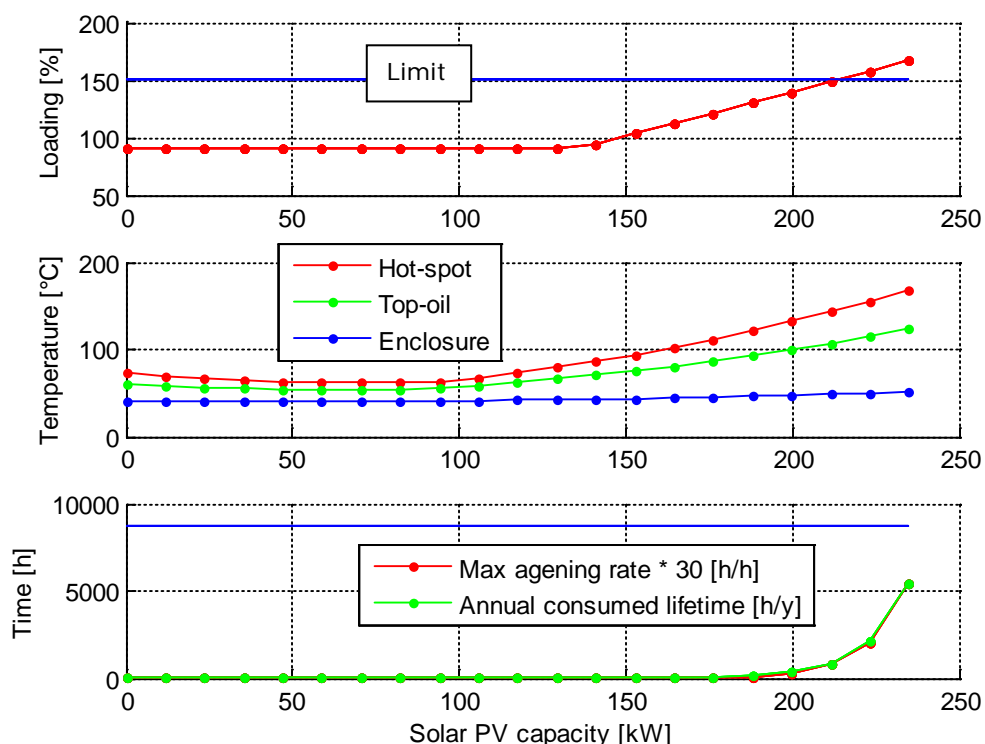

Figure 31. Yearly transformer overload situation with respect to the increasing PV penetration on a 100 kVA transformer. Note: Data is based on the studies in PVNET.dk project [21].

This problem can also be reflected from grid loss analysis. Studies in [19] [22] show that the grid losses can be reduced in general at low penetration levels until

reach a critical penetration level. Afterwards the grid losses will increase more rapidly regardless of the control methods used, as shown in Figure 32.

Finally, the economic value of change in transformer life time and cable losses is accessed and depicted in Figure 33. The critical point is found to be approximately 60 – 70 % of the transformer size, e.g. 60 – 70 kWp on a 100 kVA transformer.

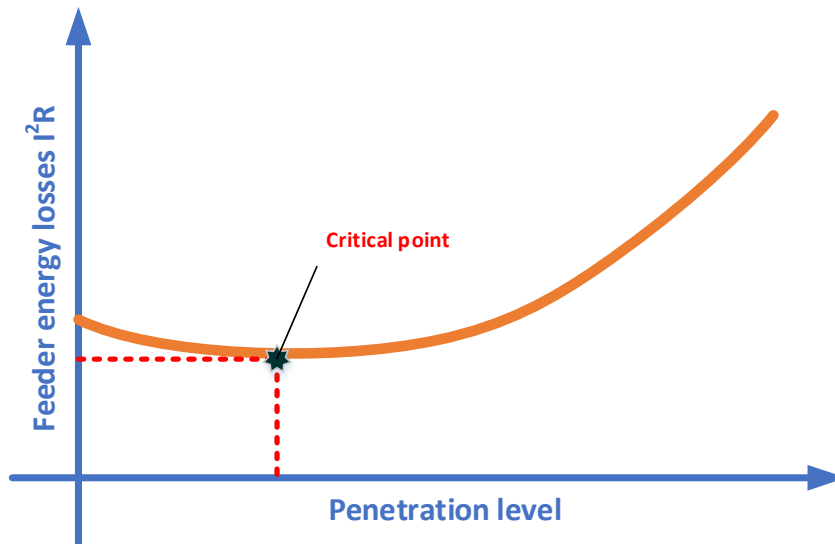

Figure 32. The developing of grid losses with respect to PV penetration level.

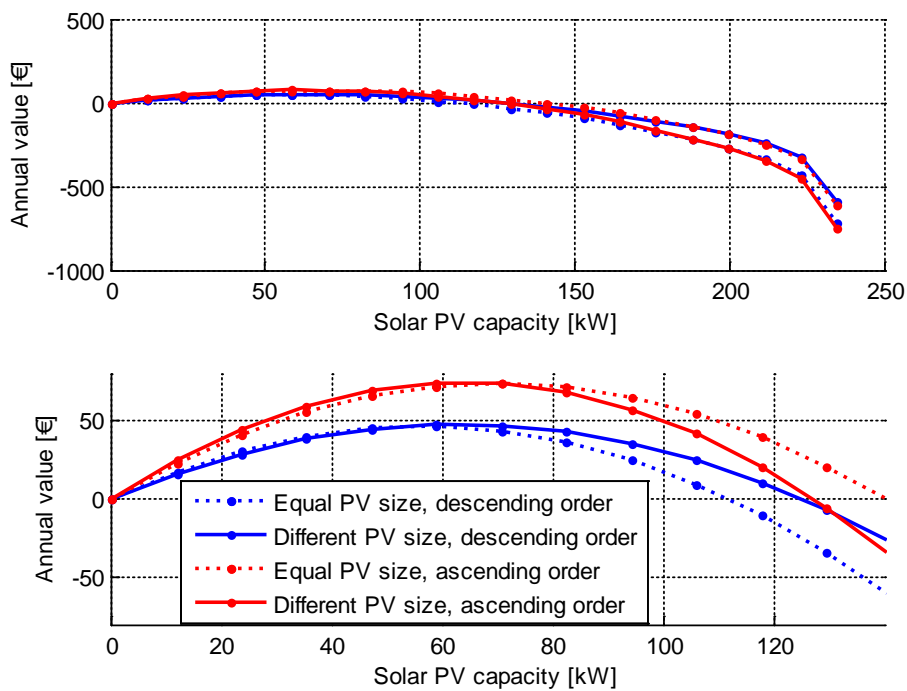

Figure 33: Annual value of solar PV systems in a residential distribution grid, fed by a 100 kVA transformer. The lower plot is a zoom of the upper [21].

1.5.10 Communication of PV inverters

Communication is essential to enable advanced power management functions from distributed PV plants. With slight addition cost, PV inverters will be able to exchange information with external devices through communication networks such as Ethernet, and hence the monitoring and control functions of PV inverters can be made accessible remotely. For example, system operators can poll the electric measurements from PV inverters to monitor the grid conditions, or send out control settings, eg active/reactive power set-points, $\cos\phi$ set point, tripping signal to PV plants for advanced operational functions.

Inverter manufacturers are interested in communication features to their devices to better fit in the current smart grid initiatives. On the other hand, communication is going to be part of the grid connection requirements in Europe [23]. Manufacturers often have their own communication protocols and data formats, standardisation is important to have a common information model to ensure the interoperability and plug-and-play of PV plants. Current initiatives include IEC 61850-5 [24], and IEC 61850-90-7 which has been mapped into the Sunspec communication profile [25], etc.

In the project we tried to develop the communication interface with Danfoss inverters, where a snapshot of the data collected from inverters is given in Figure 34. The system is not working as expected, since there are lots of IT and protocol issues that could not be find out due to lack of standardization.

From the project we found that communication is an urgent issue for fully utilizing the existing functions of PV inverters. By the time of the reporting, many PV inverters have chosen open data protocol Sunspec Alliance to enhance the interoperability. This will be one of the essential problems in future in case if grid operators would like to use the inverter data for grid monitoring and observability.

ID	Time	U L1	U L2	U L3	U L1-L2	U L2-L3	U L3-L1	I L1	I L2	I L3	P L1	P L2	P L3	VAR L1	VAR L2	VAR L3	F mean	F L1	F L2	F L3	PowerWt adj max	VAR Gase	VAR Gase lead of lag	VAR Cos(φ)	VAR Cos(φ) lead of lag	
416458	2016-05-10T22:12:40.46	236.70	240.20	238.30	413.60	412.20	413.20	0.00	0.00	0.00	0.00	0.00	0.00	0.00	0.00	0.00	50009.00	50010.00	50010.00	50010.00	100.00	0.00	false	1.00	false	0.00
416458	2016-05-10T22:12:33.453	236.80	240.30	238.40	413.80	412.30	413.30	0.00	0.00	0.00	0.00	0.00	0.00	0.00	0.00	0.00	50022.00	50022.00	50022.00	50023.00	100.00	0.00	false			0.00
416455	2016-05-10T22:12:08.453		240.30	238.40	413.80	412.40	413.50	0.00	0.00	0.00	0.00	0.00	0.00	0.00	0.00	0.00	50038.00	50037.00	50037.00	50036.00	100.00	0.00	false	1.00	false	0.00
416453	2016-05-10T22:12:19.453	237.10	240.30	238.50	414.10		413.70	0.00	0.00	0.00	0.00	0.00	0.00	0.00	0.00	0.00	50048.00	50048.00	50048.00	50048.00	100.00	0.00	false	1.00	false	0.00
416451	2016-05-10T22:12:12.447	237.30	240.70	238.90	414.60	413.10	414.20	0.00	0.00	0.00	0.00	0.00	0.00	0.00	0.00	0.00	50042.00		50044.00	50044.00		0.00	false	1.00	false	0.00
416449	2016-05-10T22:12:06.447	237.10	240.80	239.00	414.70	413.30	414.00	0.00	0.00	0.00	0.00	0.00	0.00	0.00	0.00	0.00	50031.00	50032.00	50032.00	50032.00	100.00	0.00	false	1.00	false	0.00
416448	2016-05-10T22:11:58.47	237.40	240.60	238.90	414.40	413.00		0.00	0.00	0.00	0.00	0.00	0.00	0.00	0.00	0.00	50029.00	50030.00	50029.00	50029.00	100.00	0.00	false	1.00	false	0.00
416444	2016-05-10T22:11:31.557	236.90	240.70	238.90	414.30	413.40	413.70	0.00	0.00	0.00	0.00	0.00	0.00	0.00	0.00	0.00	49993.00	49993.00	49993.00	49993.00		0.00	false	1.00	false	0.00
416442	2016-05-10T22:11:24.557	236.90	240.30	238.90	413.80	413.10	413.70	0.00	0.00	0.00	0.00	0.00	0.00	0.00	0.00	0.00	50011.00	50011.00	50011.00	50011.00	100.00	0.00	false	1.00	false	0.00
416441	2016-05-10T22:11:17.577	237.40	240.80	239.10	414.90	413.80	414.20	0.00	0.00	0.00	0.00	0.00	0.00	0.00	0.00	0.00	50045.00	50046.00	50046.00	50046.00	100.00	0.00	false	1.00	false	0.00

Figure 34. System developed in the project polling data from inverters at Bornholm.

1.5.10.1 Regulatory issues for PV integration

Some of the lesson learned in this project is the need for specific codes and standards for communication and communication language if the utility sector wants to use inverters in direct regulation and control of the grid.

The IEC 61850-90-7 Technical Report has been mapped in to the Sunspec Alliance Inverter Control profile and is ready to be applied. During the project, the Danish Technical Requirements TF 3.2.1 and TF3.2.2 was updated to accommodate the Sunspec profile.

When starting controlling and regulate inverters owned by private customer´s and investors clear rules have to be set up in this respect. This could be issues such as value of the inverter service beyond energy, compensation of loss of energy etc.

1.6 Utilization of project results

The project results will serve as basis for a number of activities.

The reactive power function of inverters is testified in the project. Further the functions can be utilized by grid operators for volt-var regulation.

Knowledge used in DSI – The knowledge obtained during the PVNET project was used to design the ancillary functions and controller for the MLX inverters, such that the MLX inverters are fully compliant with the IEC 61850-90-7. This would not have been possible without the PVNET project.

Knowledge used at Østkraft – set up a model for purchasing reactive power from solar PV in future.

Knowledge used in EnergiMidt – new projects, potential new solutions for PV system operation.

Grid operators should utilize the functions of inverters for power quality enhancement.

The PV testing platform will serve as educational resources for the students who would like to learn the connectivity of PV inverters and operation of microgrid.

The lessons learnt from the project will be used for PV integration training courses for practical applications.

The research results of the project can serve as background for further studies, student projects, etc.

1.7 Project conclusion and perspective

The global trend on PV energy adoption will continue in the next few years. The ever-decreasing cost of PV systems will accelerate the process. Currently, grid operators, both at transmission and distribution levels, have seen opportunities for utilising PV systems to solve different kinds of grid issues.

However, in many countries, utilities of electric distribution grids are reluctant to have large amounts of PV energy, and far from exploiting the current PV system technology for operational security. The functionalities of PV inverters, though

many are required by the grid operators, are still only considered “nice to have,” instead of “essential to have.” The opportunities provided from the current PV technologies need to be further turned into general solutions to aid the PV integration.

Our work shows that the distribution network operator can actually save cost by having a certain amount of solar PV in their networks (60 – 70 % of transformer size). This originates from lower losses in the infrastructure and to some extent also lower consumption of life time of the transformers.

Utilities must realise that the grids under operation will have different characteristics than the previous. This change calls for new operational practices in terms of operation and control. Operational tools are to be developed for the distribution system operators to enable them proactively operate the grids to mitigate the possible risks and adapt to the new situation.

The current power electronic technologies enable PV plants operate flexibly in electric grids. Most PV systems currently installed, however, have relatively smaller sizes than other power plants. This jeopardizes the control efficacy of individual PV systems. The present results, however, are focus on utilising the control of PV systems for solving local issues, than providing services to the entire grids.

Provided by standardised communication capabilities of PV plants, an important R&D issue is the design advanced control strategies and algorithms for integrating the control effects of many PV systems, and/or with other decentralised systems, to improve the control efficacy and reliability. Especially an hassle-free setup of “the last mile” of communication, based on already communication infrastructure at the customers, without compromising cyber security.

Electric grids are planned to meet the changes from generation and demand based on prediction of operational scenarios in the future. In order to determine a cost-effective solution for reinforcement, operational scenarios need to be further developed with more PV plants with account for the control capabilities from PV and other emerging technologies.

The technical solutions developed for PV systems will not work well in reality without economic or social incentives. New market mechanisms are required to foster the development of technical solutions as well as the implementation.

The gap between the opportunities that PV system can bring and a fully integration needs to be filled up before larger PV energy adoption. The process requires integration of the progress on technical, economical and regulatory sides.

Full list of dissemination

Journal Publications

G. Y. Yang, et. al, “Voltage rise mitigation for solar PV integration at LV grids”, Journal of Modern Power System and Clean Energy, vol. 3,

Status

Published

no. 3, pp 411-421, September 2015. DOI:10.1007/s40565-015-0132-0 (Open Access).

Miguel Juamperez, Guangya Yang, Søren Bækhøj Kjær, "Voltage regulation in LV grids via coordinated volt-var control strategies", Journal of Modern Power System and Clean Energy, 2014. DOI:10.1007/s40565-014-0072-0 (Open Access).

S. M. Hashemi, J. Østergaard, and G. Y. Yang, A Scenario-Based Approach for Energy Storage Capacity Determination in LV Grids with High PV Penetration, IEEE Transactions on Smart Grids. Published

Can Wan, Zhao Xu, Guangya Yang, Pierre Pinson, Arne Hejde Nielsen, Jacob Østergaard, "Probabilistic Wind Power Forecasting with Hybrid Artificial Neural Networks", Electric Power Components and Systems, 2016. Published

Can Wan, Jin Lin, Yonghua Song, Zhao Xu, Guangya Yang, "Probabilistic Forecasting of Photovoltaic Generation: An Efficient Statistical Approach", IEEE Power Engineering Letters, in press. Published

Book & book contributions

Status

Francesco Marra, Guangya Yang, "A Decentralized Storage Strategy for Residential Feeders with Photovoltaics", chapter in Energy Storage for Smart Grids: Planning and Operation for Renewable and Variable Energy Resources (VERs), Elsevier Inc.. Published

Guangya Yang, Francesco Marra, Seyedmostafa Hashemi Toghroljerdi, Arne Ravndal Finnby, "Storage in Distributed Generation Systems", Chapter 12, DTU International Energy Report, 2013. Published

Conference Publications

Status

Pierre-Jean Alet, Venizelos Efthymiou, Giorgio Graditi, Norbert Henze, Mari Juel, David Moser, Franko Nemas, Marco Pierro, Evangelos Rikos, Stathis Tselepis, Guangya Yang, Forecasting and observability: critical technologies for system operations with high PV penetration, European Photovoltaic & Solar Energy Conference and Exhibition, 2016. Published

C. Garcia Bajo, S. Hashemi, S.B. Kjær; Guangya Yang, J. Østergaard, "Voltage unbalance mitigation in LV networks using three-phase PV systems", IEEE International Conference on Industrial Technology (ICIT), Sevilla, Spain, 17-19 March 2015, pp.2875-2879. doi: 10.1109/ICIT.2015.7125522 Published

P.-J. Alet, Federica Baccaro, Matteo De Felice, Venizelos Efthymiou, Christoph Mayr, Giorgio Graditi, Mari Juel, David Moser, Franko Nemas, Marcello Petitta, Stathis Tselepis, Guangya Yang, "Quantification, challenges and outlook of PV integration in the power system: a review by the European PV Technology Platform", EU PVSEC 2015. Published

Søren Bækhøj Kjær, Guangya Yang, Jacob Østergaard, Kenn H. B. Frederiksen, Hans Henrik Ipsen, "Costs of residential solar PV plants in distribution grid networks", EU PVSEC 2015. Published

S. Hashemi Toghroljerdi, W. Heckmann, D. Geibel, T. Degner, and J. Østergaard "Application of MV/LV Transformers with OLTC for Increasing the PV Hosting Capacity of LV Grids," 2015 European Photovoltaic Solar Energy Conference and Exhibition (EU PVSEC 2015). Published

Søren Bækhøj Kjær, "Grid voltage control by Pf(U) regulation", 29th EUPVSEC, Session 5BV.2.48, pages: 2960 - 2964, 2014. Published

DOI:10.4229/EUPVSEC20142014-5BV.2.48.

S. Hashemi Toghroljerdi and J. Østergaard, "Energy Storage Management in Residential Feeders with High PV Penetration for Overvoltage Prevention", 40th IEEE Photovoltaic Specialists Conference, Denver, Colorado, 2014. Published

S. B. Kjær, R. D. Lazar, H. P. Ballegaard, G. Y. Yang, J. Østergaard, H. H. Ipsen, K. H. B. Frederiksen, "Voltage control in low voltage networks by photovoltaic inverters – PVNET.dk", 28th European Photovoltaic Solar Energy Conference and Exhibition, Paris, France, Sept. 2013. Published

S. M. Hashemi, Guangya Yang, Jacob Østergaard, Shi You, and Seung-Tae Cha, "Storage Application in Smart Grid with High PV and EV Penetration", 4th European Innovative Smart Grid Technologies Conference, Copenhagen, Oct. 6-9 2013. Published

S. M. Hashemi, J. Østergaard, and G. Y. Yang, "Effect of Reactive Power Management with PV Inverters on Energy Storage Capacity Required for Overvoltage Prevention in Residential Area with high PV Penetration", 39th IEEE Photovoltaic Specialists Conference, Tampa Convention Centre, Florida, Jun. 16-21, 2013. Published

Radu Lazar, et al., "Voltage balancing in LV residential networks by means of three phase PV inverters", EUPVSEC conference, Frankfurt, GERMANY, September 24th - 28th 2012. Published

G. Y. Yang, et al., "Analysis of Thevenin equivalent for solar integration based on a real case", IEEE PES Innovative Smart Grid Technologies Europe Conference, 2012. Published

S. M. Hashemi, G. Y. Yang, and J. Østergaard, "Determination of PV penetration in LV networks considering stochastic behavior of loads and PVs", 2nd International Workshop on Integration of Solar Power into Power Systems, Oct 2012, Lisbon. Published

Christian Benz, et al., "Spannungsunsymmetriekompensation in Niederspannungsnetzen durch dreiphasige Solarwechselrichter", Symposium Photovoltaische Solarenergie, Bad Staffelstein, GERMANY, March 2012, 27. Published

Søren Bækthøj Kjær, et al., "Smart integration of photovoltaic power systems on the island of Bornholm", 1st International Workshop on Integration of Solar Power into Power Systems, Århus, DENMARK, October 24th 2011. Published

G. Y. Yang, etc, "Smart integration of photovoltaic power systems on the island of Bornholm", 1st International Workshop on Integration of Solar Power into Power Systems, Aarhus, Oct. 23-24, 2011. Published

S. B. Kjær, R. D. Lazar, U. Borup, J. Østergaard, G. Y. Yang, C. Stephansen, J. B. Sørensen, "Application of SmartGrid in Photovoltaic Power Systems on the Island of Bornholm – PVNET.dk", 26th European Photovoltaic Solar Energy Conference and Exhibition, Hamburg, Germany, September 5th - 9th 2011. Published

Outreach

Status

P.-J. Alet, Federica Baccaro, Matteo De Felice, Venizelos Efthymiou, Christoph Mayr, Giorgio Graditi, Mari Juel, David Moser, Marcello Petitta, Stathis Tselepis, Guangya Yang, "Status review of PV integration into power grids", white paper for EU PV technology platform. Published

- Søren Bækhøj Kjær, et al., "Solar power gets smart", ResearchMedia, p61-63, November 2012 Published
- Søren Bækhøj Kjær, Kenn H. F. Frederiksen, Guangya Yang, Hans Henrik Ipsen, "Systemydelse fra solcelleanlæg", in press KOGL (in Danish). Published
- Guangya Yang, tutorial on "Grid integration of solar PV - issues, lessons learnt, and outlook", IEEE SmartGrid Comm, 06-09, November 2016. To be given

Internal project reports

Status

- Miguel Jumperez, Review of Voltage Control Strategies for Distribution Power Networks with High DG Share, 2013. Unpublished
- Adrian Constantin, Radu Dan Lazar and Søren Bækhøj Kjær "Voltage control in low voltage networks by Photovoltaic Inverters – PVNET.dk", technical report, Danfoss Solar Inverters, December 2012. Published
- Adrian Constantin, et al. "Current control stability for Danfoss TLX inverters in a generic distribution system in Bornholm", technical report, Danfoss Solar Inverters, November 2012. Published

Conference presentations

Status

- B.C. Nepper-Rasmussen, T.B. Rasmussen. "Optimal Design of PV and HP System". In: Visual PRESENTATIONS 6AV.4 PV supporting electrical and thermal energy systems, EUPVSEC September 2015. Finished
- G. Y. Yang, "Implementation of coordinated voltage control at LV grids for solar integration", presented at IEEE Power Engineering Society General Meeting, July 27-31, 2014, Washington DC. Finished
- Kenn H. B. Frederiksen, PV Grid Forum Conference, Stockholm April 26th 2013. There was a presentation about the PVNet project itself, the outcome of the project and Danish experiences with high amount of PV in Utility networks. More information can be found at the web page: <http://www.svensksolenergi.se/nyheter/kalendarium/pv-grid-forum-stockholm> Finished
- PVnet was presented by G. Y. Yang in Seminar on Recent Research Advancement on Renewable Integration for a Reliable Future System, 6 June 2013, DTU, 2013 Finished
- PVnet was presented by G. Y. Yang in meeting with State Grid Electric Power Research Institute, august 2013, Nanjing, China. Finished

Student projects

Status

- (MSc) Impact study of large solar plants on grid frequenc, June 2016 Finished
- (MSc) Reactive power regulation for solar PV integration at LV grid, Mar 2015 Finished
- (MSc) Voltage unbalance analysis and mitigation in LV grids with PV systems, August 2014. Finished
- (MSc) Grid-connected inverter testing for ancillary service provision at low voltage grids, Dec 2013. Finished
- (MSc) Dynamic modelling of distributed generation for frequency and voltage regulation under high RES penetration, June 2013. Finished
- (MSc) Testing platform development for large scale solar integration, April 2013. Finished

(MSc) Scheduling of electricity and heating systems in a microgrid with high penetration of renewable resources, DTU March 2012. Finished

(Individual course project) Optimal design of PV and HP system Finished

(Individual course project) Implementation of remote voltage control for photovoltaic inverters Finished

Educational services, courses

DTU course 31742, Power system operation, lecture on voltage compensation in operation in LV grids; Finished

Electric Power Distribution, Automation, and Control – **DTU individual course**; Finished

Dynamic security analysis of a power system with large converter-based platforms – **DTU individual course**; Finished

2. References

- [1] "PVI B," [Online]. Available: [http://en.openei.org/wiki/PVIIsland_Bornholm,_ForskEL_\(Smart_Grid_Project\)](http://en.openei.org/wiki/PVIIsland_Bornholm,_ForskEL_(Smart_Grid_Project)).
- [2] EcogridEU. [Online]. Available: <http://www.eu-ecogrid.net/>.
- [3] MetaPV. [Online]. Available: <http://www.metapv.eu/introduction>.
- [4] G. Y. Yang, "Smart integration of photovoltaic power systems on the island of Bornholm," in *1st International Workshop on Integration of Solar Power into Power Systems*, Aarhus, 2011.
- [5] PowerlabDK. [Online]. Available: <http://www.powerlab.dk/>.
- [6] Elespec G4430. Blackbox, ELSPEC, [Online]. Available: <http://elspec-ltd.com/metering-protection/G4400-Power-Quality-Analyzer/>.
- [7] International Energy Agency, "Key world energy statistics 2015," IEA, 2015.
- [8] REN21, "Renewables 2016 Global Status Report," REN21, 2016.
- [9] IRENA, "Renewable Capacity Statistics 2016," The International Renewable Energy Agency, 2016.
- [10] FS-UNEP Collaborating Centre, "Global Trends in Renewable Energy Investment 2016," United Nations Environment Programme, 2016.
- [11] EU Joint Research Center, "Smart Grid Projects Outlook 2014," European Commission, 2014.
- [12] IEEE Std 1547-2003, "IEEE Standard for Interconnecting Distributed Resources with Electric Power Systems," IEEE, 2003.
- [13] IEC, "IEC 61400-21:2008. Wind turbines - Part 21: Measurement and assessment of power quality characteristics of grid connected wind turbines," IEC, 2008.
- [14] FGW e.V., "Technical Guidelines for Power Generating Units and Farms. Part 3 Determination of electrical characteristics of power generating units and systems connected to MV, HV and EHV grids".
- [15] BDEW e.V., "Technical guideline: Generating plants connected to the medium-voltage network," 2008.
- [16] ENTSO-E, "Network Code on Requirements for Grid Connection applicable to all Generators (RfG)," 2013.
- [17] G. Y. Yang and et al., "Analysis of Thevenin equivalent network of a distribution system for solar integration studies," in *Proceedings of the 3rd Innovative Smart Grid Technologies (ISGT Europe)*, Berlin, Germany, 14-17 Oct 2012.
- [18] S. B. Kjær, "Grid voltage control by Pf(U) regulation," in *29th EUPVSEC*, 2014.
- [19] R. D. Lazar, A. Constantin and S. B. Kjær, "Voltage control in low voltage networks by photovoltaic inverters - PVNET.dk," Danfoss Solar Inverters A/S, Nordborg, Denmark, 2013.
- [20] F. Marra, G. Yang, Y. T. Fawzy, C. Træholt, E. Larsen, R. Garcia-Valle and M. M. Jensen, "Improvement of Local Voltage in Feeders With Photovoltaic Using Electric Vehicles," *IEEE Transactions on Power Systems*, vol. 28, no. 3, pp. 3515-3516, August 2013.
- [21] S. B. Kjær and et al., "Costs of Residential Solar PV Plants in Distribution Grid Networks," in *30th European Photovoltaic Solar Energy Conference and Exhibition*, Hamburg, Germany, 2015.
- [22] M. Juamperez, G. Yang and S. B. Kjær, "Voltage regulation in LV grids via coordinated volt-var control strategies," *Journal of Modern Power System and Clean Energy*, vol. 2, no. 4, pp. 319-328, 2014.

- [23] ENTSO-E, "Network Code on Requirements for Grid Connection applicable to all Generators (RfG)," ENTSO-E, 2013. [Online]. Available: <https://www.entsoe.eu/major-projects/network-code-development/requirements-for-generators/>. [Accessed 26 May 2013].
- [24] IEC standards, "IEC 61850-5," [Online]. Available: http://webstore.iec.ch/webstore/webstore.nsf/ArtNum_PK/30929.
- [25] SunSpec Alliance, "Open Information Standards for Distributed Energy," [Online]. Available: <http://www.sunspec.org/>.
- [26] "IEEE Standard for Interconnecting Distributed Resources with Electric Power Systems," IEEE, 2003.
- [27] "PVGRID Advisory paper - Consultation version: Key recommendations," PV GRID, December 2013.
- [28] C. F. Covrig, M. Ardelean and J. Vasiljevska, "Smart Grid Projects Outlook 2014," 2014.