



Exploring product development possibilities and alternative uses of PV solar cells in Ghana

Adomdza, Gordon K. ; McBagonluri, Fred; Kemausour, Francis; Nygaard, Ivan; Hansen, Ulrich Elmer; Lauritzen, Hanne

Publication date:
2016

[Link back to DTU Orbit](#)

Citation (APA):
Adomdza, G. K., McBagonluri, F., Kemausour, F., Nygaard, I., Hansen, U. E., & Lauritzen, H. (2016). Exploring product development possibilities and alternative uses of PV solar cells in Ghana.

DTU Library

Technical Information Center of Denmark

General rights

Copyright and moral rights for the publications made accessible in the public portal are retained by the authors and/or other copyright owners and it is a condition of accessing publications that users recognise and abide by the legal requirements associated with these rights.

- Users may download and print one copy of any publication from the public portal for the purpose of private study or research.
- You may not further distribute the material or use it for any profit-making activity or commercial gain
- You may freely distribute the URL identifying the publication in the public portal

If you believe that this document breaches copyright please contact us providing details, and we will remove access to the work immediately and investigate your claim.



Exploring product development possibilities and alternative uses of PV solar cells in Ghana

Gordon K. Adomdza, Ashesi University

Fred McBagonluri, Ashesi University

Francis Kemausour, Kwame Nkrumah University of Science and Technology (KNUST)

Ivan Nygaard, UNEP DTU Partnership, DTU Management Engineering

Ulrich Elmer Hansen, UNEP DTU Partnership, DTU Management Engineering

Hanne Lauritzen, DTU Energy

2016

Exploring product development possibilities and alternative uses of PV solar cells in Ghana

Report File no. 104.GHANA.809-200
2016

By

Gordon K. Adomdza, Ashesi University

Fred McBagonluri, Ashesi University

Francis Kemausour, Kwame Nkrumah University of Science and Technology (KNUST)

Ivan Nygaard, UNEP DTU Partnership, DTU Management Engineering

Ulrich Elmer Hansen, UNEP DTU Partnership, DTU Management Engineering

Hanne Lauritzen, DTU Energy

Copyright: Reproduction of this publication in whole or in part must include the customary bibliographic citation, including author attribution, report title, etc.

Cover photo: Testing of OPV cell phone charger at Ashesi University

Published by: Department of Energy Conversion and Storage, Frederiksborgvej 399, 4000 Roskilde
www.dtu.dk

Contents

Executive summary.....	3
Conclusion	4
Extended summary.....	7
1. Introduction.....	11
2. Ghanaian energy policies.....	14
2.1 Methodology	14
2.2 Policy support for OPV development in Ghana.....	15
2.3 View of solar energy stakeholders in Ghana	20
2.4 Conclusion	26
References chapter 2.....	27
3. The market for small-scale solar PV in Sub-Saharan Africa.....	28
3.1 Market development for small scale solar power.....	29
3.2 Emerging business and delivery models of solar applications.....	36
3.3 Regional industrial actors on the SSA market for lanterns and chargers.....	39
3.4 Global standards, regulation and support programs - lanterns and chargers	41
3.5 Differences in market development in East and West Africa	42
3.6 Conclusion	44
References chapter 3.....	45
4. The Ghanaian market for small-scale solar products.....	47
4.1 The actors present in the market	49
4.2 Marketing Strategies	52
4.3 Distribution.....	52
4.4 Training.....	54
4.5 After sale service and support.....	54
4.6 Conclusion	55
5. Openings for OPV on the Ghanaian market	56
5.1 The need for solar energy and portable power.....	56
5.2 Perception of products made of OPV.....	59
5.3 OPV product ideas for the Ghanaian market	61
5.4 Conclusion	63

6.	Local production and knowledge platform	64
6.1	Local design and assembly of OPV product.....	65
6.2	Local processing of OPV modules.....	66
6.3	Conclusion	68
APPENDIX 1: POLICY		70
A1.1	List of stakeholders consulted.....	70
A1.2	Beginning of implementation of the 200,000 solar rooftop programme.....	71
A1.3	Questionnaire for Stakeholder Interviews.....	72
APPENDIX 2: MARKET.....		75
A2.1	Market prices for solar lanterns.....	75
A2.1	Lighting Africa quality verified products	77
A2.3	Photo Album showing products available from retailers in Accra.....	81

Executive summary

This project and report concerns the contract “Exploring product development possibilities and alternative uses of PV solar cells in Ghana” between DTU and The Royal Danish Embassy in Accra (file no. 104.GHANA.809-200). The objective of this project is to evaluate if it is feasible or not to establish a Ghanaian self-sustained business rooted in organic photovoltaics.

The investigations undertaken show that the Ghanaian policies are in favour of solar energy and local manufacturing of solar products, and that the market for small PV systems offering charging via USB ports and LED lightening is taking off in West Africa. This market, also called the pico market, is highly suited for OPV's performance profile. The pico market is expected to grow in West Africa in the coming years and by this create an interesting opening for Ghanaian produced OPV systems. The target customers in Ghana are non-electrified dwellers and the large fraction of the workforce working outdoor with limited or no grid-access during the day (street hawkers, mobile credit vendors, mechanics, masons, carpenters etc.). Chinese products are already strongly present in the pico market, and the OPV products need to offer low cost and added values to be competitive on this market. Robust low-weight products that are easy to carry with you and products that also can be used for shading from the intense sun will be valuable. Operating on the Ghanaian PV market is challenging, and marketing, sales and distribution are best covered by teaming up with experienced actors.

Ghana has a knowledge platform that is adequate for building a local business on assembly of OPV products for the pico market, but what is needed is to build a strong portfolio of product for this market. The Ghanaian knowledge platform for carrying a domestic production of OPV modules is more limited, but local industrial expertise in roll-to-roll printing serves as a good fundament to build on. DTU technology for roll-to-roll processing of OPV modules is ready for transfer to a skilled industrial receiver. The conditions for a transfer have to be negotiated. Local universities already involved in the OPV technology should be encouraged to complement their present research activities with technology disciplines that can support a local producer.

The overall conclusion of the project is that it is feasible to build a local industry based on the OPV technology. Industry on assembly of OPV products can be built as soon as a promising portfolio of products is identified. This should be done by arranging a workshop for stakeholders in PV technology, product design and entrepreneurship. This should be done as soon as possible to follow the development of the regional market. Another urgent task is to collect data on the durability of OPV modules under the local weathering conditions and under relevant user scenarios. Building local manufacturing of OPV module should await a build-up of the regional demand, but it has to be prepared in due time as building the required technological competences takes time.

Conclusion

The conclusion of the project and the answers to the questions listed in the project contract's Term of References are as follows:

- **The local Ghanaian policies are in favour both of solar energy and of local production of solar products.** Any business in the sector that seeks to reduce the cost of solar modules in particular will be greatly supported. Government also has no intention to restrict the export of solar OPV if it were manufactured in Ghana, and the government would want to make Ghana the manufacturing hub for solar products in the West African region and beyond. *(question d)*
- **There African market for small PV systems, the so-called pico segment offering USB charging and LED lightening, is perfectly suited for OPV.** The market is driven by reduced cost combined with attractive purchase-hire models reducing the upfront cost to be paid by the consumer. The market is characterized by strong competition from China and high focus on cost due to the target customer's low purchasing power. Traditionally the market has been served by donor projects, but reduced prices and "pay-as-you-go" solution with low upfront cost has opened the market also for individual customers. Presently this market is taking off in East Africa, and this tendency is expected to spread to West Africa and Ghana in the coming years. The key target Ghanaian customers to low-cost pico products are to be found among the non-electrified households and the workforce spending most of the day outside without grid-access. More stylish versions of pico-scale products can be targeted the middleclass and their request for a comfortable life. OPV has to deliver on cost, quality and style to enter the market successfully. A manoeuvre on the Ghanaian market for solar cells is challenging, is advisable to team up with local partners experienced in marketing, sales and distribution. *(question b)*
- **The Ghanaian knowledge platform for setting up a local business on assembly of OPV products is adequate, i.e. it covers electronic circuitry design, basic PV technology and general product development/design.** The following companies have knowhow and infrastructure that adequately can support the build-up of such an industry: Tradeworks and Strategic Power Solutions on assembly of solar panel, Deng and Wilkins Engineering of assembly of lanterns plus RLG Electronics and Group Nduom Electronics on assembly of electronics. This knowledge base should be matched by general design and manufacturing competences available in local industry, at universities and engineering colleges. OPV modules and electronic components should be sourced on the international market. *(question c)*
- **A local business on assembly of OPV products could be established tomorrow as the technology needed is available, but for building a sustainable business a competitive product portfolio and capable entrepreneurs have to be identified.** For initiating this process the project team recommends the organisation of a workshop on OPV product design targeted at mix of designers, entrepreneurs and technically skilled stakeholders. The workshop should dress the participant for the task by giving them an understanding of basic design principle for PV products and the characteristics of the OPV technology, by encouraged to form teams holding the required competences and by supervising the team's development of own ideas. *(question e and g)*

- **The production of appealing and cost-effective products in Ghana for the local and regional market hinges on the identification of the right products for these markets and the cost-effective assembly of the products.** As the market for pico PV products already is populated with a great variety of products, for entering the market OPV products need a sharp cost profile, reliable data on the durability/operational life time, compliance with local standards and preferably Global Lighting quality verification. Generation of data on operational life time takes time and should encompass both data on the durability of the OPV modules under the local weathering and durability of the product under realistic user scenarios. Collecting data for the durability of the OPV modules itself is generic and should start as soon as possible. Products with relevance not only for Ghana but for regional West African should be preferred in order to benefit from economy of scale both in production and in sourcing. *(question a)*
- **The build-up of a local production of OPV modules could adequately rest on Margin Groups' knowhow in and infrastructure for roll-to-roll printing. The local R&D in the field of OPV has to be strengthened in order to serve a producing company.** Building a business on local production of OPV modules requires understanding of the OPV technology, knowhow in and infrastructure for roll-to-roll print processing and an understanding of the international PV market. Margin Group is relevantly anchored in roll-to-roll printing technology but will need to build an understanding of the OPV technology and the PV market – issues they seem both interest in and dressed for. As OPV is fast developing technology, the industry needs bonds to R&D for having access to the latest development trends and for advisory about best practice. The present university R&D in the field of OPV has to turn its focus from science to technology for serving as an adequate support for this. The timing is essential as preparing for local manufacturing is not done overnight, but local manufacturing should not be established before the local/regional demand can carry the high production volumes of roll-to-roll processing. *(question c)*
- **DTU's technology for roll-to-roll processing of OPV modules is in its current stage ready for transfer to a skill receiver as Margins Group.** The means for successful technology transfer are: training of personnel, set up of the adequate machinery and access to feed materials. The required feed materials (printing inks, printing substrates and encapsulation foils) and dedicated roll-to-roll machinery are available on the commercial market. Transfer of knowhow and training of personnel are to be discussed and negotiated with DTU and infinityPV who are experts in and owners of the technology. *(question f)*

The recommended next steps are:

- **Develop a portfolio of OPV products** for the West African market. This process is most conveniently initiated by arranging a targeted workshop on design and development of OPV products. Host for the workshop could be Ghana Climate Innovation Center (GCIC) or Ashesi University College as they are strong in the cross field of engineering, design, entrepreneurship and business development.

- **Launch a program for generation of operational lifetime data for OPV modules** under local weathering conditions and under relevant user profiles. This should be anchored in a technological environment skilled in PV measurements f.ex. KNUST or Kumasi Polytechnics.
- **Seek for relevant project calls that can finance joint Ghanaian-Danish R&D projects in the field of OPV.** Such projects should target the built up of technological competences in OPV and relevant production technology (solution processing/printing) at the local universities already involved in research in OPV (KNUST, University of Ghana). Margin Group might be an interested industrial partner in such project as printing technology is relevant for their running business and project creates a valuable opening for evaluating OPV as a possible new business area for them.
- **Establish a function for following the solar pico market in West Africa closely** and this is most conveniently done in close contact with companies already holding strong positions on the market, for example Deng.

And also to identify grants that can finance these activities.

Extended summary

This project and report concerns the contract “Exploring product development possibilities and alternative uses of PV solar cells in Ghana” between DTU and The Royal Danish Embassy in Accra (file no. 104.GHANA.809-200). The objective of this project is to evaluate if it is feasible or not to establish a Ghanaian self-sustained business rooted in organic photovoltaics. In order to conclude on this the project encompass a review of the Ghanaian policies on energy, a survey of the African market for small PV systems as this is the segment suited for organic photovoltaics (OPV) and a review on the local knowledge platform upon which a self-sustained Ghanaian OPV business can be built.

Policy

The government of Ghana in its effort to increase the share of renewable energy in the national energy mix has shown commitment through the development of a number of national policies and interventions to provide friendly environment for the development and utilisation of renewable energy. All the policy and planning documents advocate support for cheaper solar technologies and offer to support local manufacture as well as provide incentives and other support systems. The Strategic National Energy Plan (2006 recommended government subsidises as well as import duty and tax exemption for renewable energy equipment, appliances and system component. These recommendations were later considered in the RE Act of 2011. Currently, importers in Ghana enjoy a “zero” import duty on solar panels and complete solar systems imported into the country. However and in order to comply with ECOWAS regional policy, tariff incentives on solar products and components were removed in January 2016.

The policy also indicated the need for government to support the promotion of local manufacturing of renewable energy devices and equipment in the medium-to-long term. The NEP states that any business in the energy sector that seeks to reduce the cost of solar modules in particular will be greatly supported. These policies provide a fertile ground for the development of solar OPV and related businesses in Ghana.

Policy makers consulted as part of the study indicated that government will accept a manufacturer who intends to set up a solar OPV manufacturing plant in Ghana provided the product is of good quality. Government also has no intention to restrict the export of solar OPV if it is manufactured in Ghana. As a matter of fact, government would want to make Ghana the manufacturing hub for solar products in the West Africa region and beyond. A Renewable Energy Master Plan currently under development may also support solar OPV with incentives.

The review of policies concludes that Ghana’s energy plans and policies are conducive for the introduction of solar OPV technology in Ghana. It is not expected that any regulation would hinder the manufacture or importation of solar OPV products. The most critical aspect is for any solar OPV business, whether imported or locally manufactured, to meet local standards and go through the right registration processes. It must be noted, however, that most government programmes are aimed towards ultimately, a local manufacture of solar components in the country and this would be given favourable consideration. A possible hindrance to adopting solar OPV technology on the part of consumers is the currently low awareness of the technology. Clearly, not many Ghanaian consumers are aware of the potential opportunities and economic benefits offered by solar OPV and this could derail uptake. To pump up interest, a serious awareness campaign would have to be undertaken that spells out the unique benefits of solar OPV technology, and an assurance of its operability in Ghanaian communities.

The Sub-Saharan African market

Given the increasing globalised markets for small scale PV appliances, the feasibility of establishing an OPV business in Ghana PV cannot be seen isolated from the Sub-Saharan African (SSA) and the global market. Therefore, a desk top review of the current and the expected market for small scale PV in Sub-Saharan African (SSA) have been made. The review focusses on small solar home systems (SHS) and pico-scaled systems. Small systems for non-electrified households are normally in the range of 5-100 W_p.

Over the last 5 years the SSA market for pico systems has increased from <100,000 units per year to > 4 million units per year. Kenya, Ethiopia, Tanzania and Uganda are the front runners. Currently the large sale seen here is spreading to other countries in the region. The number of manufacturers of solar lanterns and chargers has increased in line with the increase in sales, and the number of known manufacturers of pico-solar products increased from 15 to 105 in the period 2010-2015. In 2009 the World Bank/Lighting Global introduced a quality verification program for pico solar products. Today 54 products are accredited. This has ensured truth in advertising and a baseline level of quality for these products and helped maintain consumers trust in PV products in spite of cheaper and lower quality products on the market.

The factors driving the East African market for pico systems targeting the non-electrified customer are more, but among them are decreasing system cost and emergence of advanced hire-purchase sales models seem to be the most important. The reduced system cost is not primarily a consequence of the sharply decreased cost of solar modules on the world marked in the same period, but a consequence of the widespread of energy-efficient appliances such as for example LED light bulbs and LED-based TVs. Today pico-systems provide the same services as much larger solar home systems did only 10 years ago. The price range for pico systems providing USB charging services of basic appliances such as lantern, cell phone, radio and a torch is 10-40 USD, whereas the price range 50-150 USD give also access to powering of multiple LED lights and a small TV.

Hire-purchase models allow the customer to pay a share (30-50 %) of the system cost upfront. The rest is paid in fixed instalments or in advanced Pay-As-You-Go systems where the customer has access to the service, for example light, as long as he/she is in advance with payment. The latter allows the payment to be divided into the smallest possible unit; the cost of electricity for one day. The most successful Pay-As-You-Go company operating in East Africa, M-KOPA, has recently started operation in Ghana under the name PEG Ghana.

For OPV to enter the market for off-grid electricity, it has to be competitive on cost for a complete system supplying the services the customers ask for. The service should include a purchase-hire scheme that reduces the upfront cost. The most viable route to the market seems thus to be via an established actor in the market who provides everything that is not OPV specific. Quality verification via Lighting Africa is recommended.

The Ghanaian market

The demand for solar power in Ghana is somewhat different from Africa in general and from its neighbouring countries due to Ghana's high electrification rate (76%) and the affluent middle class. The middle class requires modernity with the consequence of a sharp increase in electricity demand and quadrupling of the cost of electricity since 2012. The general perception of solar systems in Ghana is that: i) it is not useful for me, because the energy provided is not sufficient for covering my need (high-end

consumers typically with fully air conditioned large house), or ii) it is useful for me because I need to charge my cell phone, I need light etc., but I cannot afford it. The obvious openings for OPV in this market are systems providing off-grid electricity and systems designed to cut the top off the wealthy households' high electricity bill. Systems for the wealthy households could be solar powered sprinkler systems, security systems, exterior lightening etc. Systems for off-grid electricity are portable chargers making the life easier/more comfortable for the high-end customer and systems providing light and charging capacity to the non-electrified dwellers and the large fraction of the work force (street hawkers, mobile credit vendors, mechanics, masons, mechanics, carpenters etc) spending most of the day outside without grid access.

Cost and designs that signals quality are critical for being competitive in all segments. Quality relates to functionality, robustness, durability and aesthetics, but the individual weighting of these factors depend on the target customer. The challenge will be to raise awareness of how pico-scaled solar system can provide value for the Ghanaian user, and that solar products do not have to "last for ever" for being valuable for the customer. This means for OPV to focus on the short term benefits, to develop comparative cost schedules for example by comparing to primary batteries, and to focus on the added value given by OPV's light weight and a flexible outline.

The Ghanaian solar energy market has traditionally been kept afloat by project financed by governmental institutions, NGOs and development agencies. At present the market is responding to the opportunities created by favourable policies, significantly increasing electricity tariffs and the change of lifestyle to modernity. Most local solar companies operate in the segments importation, distribution, marketing and sales. The actors range from "briefcase entrepreneurs" to well-established, larger companies as for example Deng and Wilkins Engineering covering the entire spectrum of solar products. Burro Brand is a strong company operating in the pico segment of the market. Marketing and sales occur via a variety of methods ranging from word of mouth, door-to-door, via Face book accounts and captured audiences (churches, at work etc.) to seminars, engagement of potential influencers and training of distributors. It is surprising to note that physical retail store selling light bulbs and electronic items, do not stock solar products. The market is challenged by negative customer experiences caused by entrepreneurs with poor knowledge of their products, costly distribution and poor after-sales service outside the main cities and delays during customs clearance forcing the distributors to bond money in stock or alternatively makes delivery slow.

For creating a sound business on distribution, marketing and sales of OPV products it is of vital importance to engage with well-reputed companies experienced in manoeuvring on the challenging Ghanaian solar market and preferably also on the market in neighbouring countries, in order to benefit from economy of scale.

Local production of OPV products and OPV modules

Setting up local manufacturing of products based on the OPV technology requires a sound base covering both infrastructure and knowhow. For this reason research has been dedicated to a definition of what the needs are and a subsequent search for partners/entities having the capacity needed. Two business models have been investigated: the assembly of OPV-power products from sourced OPV modules and the processing of the OPV modules themselves.

More Ghanaian companies hold knowhow in the field of assembly of solar products and panels which might be relevant for the assembly of OPV products. Wilkins Engineering and Deng have previously been assembling lamps and panels based on sourced silicon solar cell. Both gave up production years ago, because of competition from China and the financial crisis. At present Tradeworks and Strategic Power Solutions are heading for assembly of panels with silicon cells sourced from China.

The key component in an OPV powered product is the electronic circuitry comprised of the OPV module, a charge controller, a battery and the payload. Relevant payloads are LEDs, a cell phone charger, a power bank etc. Two Ghanaian companies were identified to have a relevant infrastructure for the assembly of the OPV specific circuitry; RLG Electronics and Group Nduom Electronics. Their infrastructure comprise both assembly lines and knowhow. Once the circuitry is in place many OPV products are within reach, and the realization of these should draw on local expertise in product design, development, and general manufacturing such as injection moulding or others relevant for making the casings.

Building a local business on processing of OPV modules is far more demanding than establishing assembly business. Processing of OPV modules requires a fundament in roll-to-roll printing processing which is available at Margins Group, and Margins Group seems to be a qualified partner if and when processing technology for OPV is to be transferred to Ghana. Lasting competitiveness in production of OPV modules requires also a running R&D effort in the field, as this is an efficient way to monitor the rapid development of the technology in the international research community. There are groups at local universities (KNUST and University of Ghana) working with the OPV technology. Their prime focus is on science. For serving as a knowledge provider to a producing company, their focus should be turned onto technology and should be enlarged in scope to also encompass processing via industrial applicable methods.

Establishing a local production of OPV modules should await a volume in the local demand which can carry the high production volumes of roll-to-roll processing.

Concluding remarks and recommended further work

The overall conclusion of the project is that it is feasible to build a local industry based on the OPV technology. Industry on assembly of OPV products can be built as soon as a promising portfolio of products is identified. This should be done by arranging a workshop for stakeholders in PV technology, product design and entrepreneurship. This should be done as soon as possible to follow the expected development of the regional market. Another urgent task is to collect data on the durability of OPV modules under the local weathering conditions and relevant user scenarios. Building local manufacturing of OPV module should await a build-up of the regional demand, but it has to be prepared in due time as building the required technological competences take time.

1. Introduction

This report concerns a preparatory study targeted at an evaluation of the prospect for establishing a Ghanaian self-sustained business rooted in the organic photovoltaic (OPV) technology under the contract “Exploring product development possibilities and alternative uses of PV solar cells in Ghana” between DTU and The Royal Danish Embassy in Accra (file no. 104.GHANA.809-200). Valuable tasks belonging to investigation have been solved by Kwame Nkrumah University of Science and Technology (KNUST) and Ashesi University. The work is done in the period January – May 2016.

The report is organized in order to give the information need for answering the specific questions listed in the contract’s terms of reference, and it comprises chapters concerning the individual sub-subjects of the project (market, policy, local knowledge platform etc). All chapters are written to be self-contained sub reports. The report also includes an executive summary, a conclusion and an extended summary holding the essential information for drawing the conclusion. A description of the context for the study is also included as a special service for the non-Ghanaian and non-African reader. The reader interested in more information than given in the present report should refer to the Ashesi report “ORGANIC PHOTOVOLTAICS PROJECT REPORT – A pre-feasibility study of the prospects of organic photovoltaic products in Ghana”.

At its present stage of maturity the OPV technology is suited for serving as source of off-grid power for low-demand electrical appliances such as cell phone chargers, LED light bulbs, radios, small fans, power banks etc. This segment of the market for solar energy systems is often referred to as the pico segment (nominal power $\sim 10 W_p$ or smaller) , where pico refers to the low nominal power of the solar modules included in these systems, typically less than about $10 W_p$. All work in the preparatory study is consequently focussed on the prospect for establishing an OPV business serving the pico market. The study comprises a review of local policies and support schemes that can facilitate or hinder such a business, a review of both the Ghanaian and the Sub-Saharan market pico-scaled solar products, and an assessment of strength of the local industrial and knowledge platform upon which a local industry can be built. From the information collected in these sub studies a conclusion on the feasibility of building a self-sustained Ghanaian OPV business is drawn.

Electricity is a great demand in Africa where only 20% of the population has access to electricity. The corresponding number for Ghana is 60% and for Asia and Latin America respectively 50% and 80%. The African challenge of low electrification rate is enhanced by an unreliable and inefficient electricity sector of poor credit worthiness and high cost of electricity provision. The average tariff is USD 0.14 per kWh which is lower than the present Ghanaian tariff of 0.25 USD/kWh, but is high compared to the Asian tariff of USD 0.04-0.07 per kWh. The African demand for electricity is fast growing and will continue to grow in line with the growth of the population, of the middle class and of the percentage of youth. Likewise the demand for electricity will grow through the increased use of electronic devices and household appliances. With a bulging middleclass, youthful and fast growing population, Africa needs to generate at least 18 million jobs a year between 2010 and 2020¹. The continent has, with a solar resource among the highest in the world, great potential for harvesting solar energy. This matched with the global decline in cost of solar PV equipment seen over the last five years is expected to significantly increase the utilization of solar energy in Africa, materialised as power plants in the 100 MW class and smaller installations at village and household

¹ Social Partners & ILO. (2015). Blueprint for Jobs in Africa. ILO and Social Partners

levels. Table 1.1 gives an overview of what kind of appliances solar energy are used for in developing countries.

Ghana is a lower middle-income country with a population of 26.4 million and an estimated population growth rate of 2.1%. Table 1.2 and figure 1.1 for more socio economic data. The total installed electricity generation capacity of 2,831 MW is dominated by hydropower (56%) and thermal power (41%), whereas oil and biomass dominates the energy mix. Being a fast developing country, Ghana is in pertinent hunger for resources and energy, but the energy supply is lagging behind due to an inadequate generation capacity. With a growing population and a middle class with attendant lifestyle changes to modernity, demand for electricity is increasing rapidly. Over the last 3-5 years Ghana has been burdened with power cuts and sharply increased electricity tariffs.

Table 1.1: Typical usage profiles of solar electricity in developing countries

Appliance	Hours of use per day	Solar System
TV	1	PICO
LED lights	4	PICO
Cellphone	1	PICO
Radio	1	PICO
Fan	4	Home system
Water-pump	6	Home-system/ mini grid
Tablet	2	Home system
Mini-fridge	22	Mini-grid
Internet Connection	24	Mini-grid
Wood lathe	1	Mini-grid
Mill Grinder Small	24	Community grid
Mill Grinder Large	24	Community grid

Table 1.2: Key socio-economic data for Ghana

Area	238,539.00 km ²
Population	26,000,000.00
GDP per capita	1,858.00 USD
Access to electricity	76.00 %
Access to Modern Energy for Cooking	22.00 %
Electricity Production	12. 870 GWh (2013 est.)
Installed Capacity	≈2,955 MW of which 1588.2 MW (being 54% are large hydro and modern renewables)

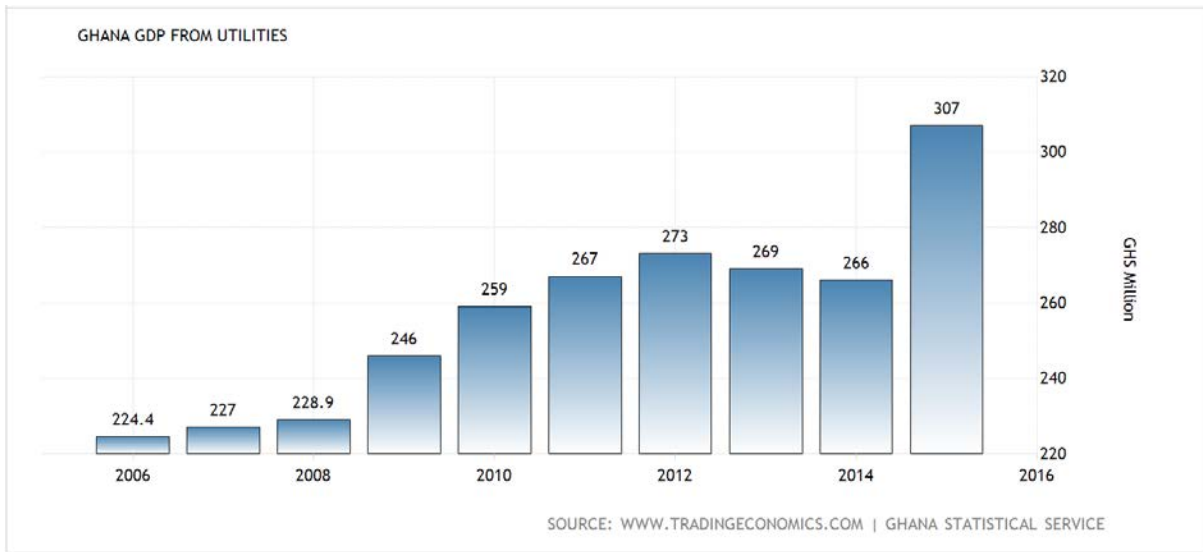

Figure 1.1: Ghana's gross domestic product from 2006 to 2015.

Situated on equator with humidity levels over 95% most of the year, accompanied by high temperatures creates high demand for cooling: shading for the sun, chilling perishables, post-harvesting crops etc. and air conditioning of buildings. The main energy consumers in the country are households and transportation. The industrial consumption is only about one-third of the residential consumption. The most common uses of electricity by households include air conditioning, refrigeration, TV music systems, mobile telephony, computers and ironing, whereas most businesses use electricity for lightening, equipment and refrigeration. The mobile phone subscription counts 115 per 100 inhabitants.

The ease of doing business in Ghana has improved over the last years in the following categories: starting a business, paying taxes, getting credit, registering property, protecting minority interests and dealing with construction permits according to the Ease of Doing Business Report 2015. However, Ghana does not fare so well in; resolving insolvency, trading across borders, enforcing contracts categories.

2. Ghanaian energy policies

This chapter seeks to clarify if there are present or upcoming Ghanaian policies and support schemes that can facilitate or jeopardize solar OPV products in Ghana.

The failure of the electricity sector in Ghana coupled with the need to take action to combat climate change and concerns of diminishing fossil fuels has led to national development agencies looking for alternative and environmentally friendly sources of energy. Current challenges in the energy sector present the need for Ghana to expand its generating capacity and also promote portable rural solutions using renewable energy sources. The development and use of renewable energy resources has the potential to ensure Ghana's energy security and to mitigate the negative impacts of climate change. Among the various renewable energy sources in the country, solar energy is one of the most promising as the resource is available throughout the country with solar irradiation potential between 4.567-5.524 kWh/m²/day (Forson *et al.*, 2004). Notwithstanding this abundant solar resource, its development in the country has not taken off as expected mainly due to high cost of solar energy equipment. Recently though, a number of private sector players have shown interest in constructing solar PV power plants to sell power to the grid. The Ministry of Energy also intends to promote small-scale applications, mainly solar lanterns and solar home systems in various programmes that are currently being implemented. Owing to a lower cost of solar OPV, there is good prospect for its development in Ghana for some of these small-scale applications. However, the development of any solar business is highly dependent on policies and initiatives that provide conducive environment for the sector. In this vein, governmental support and commitment as well as private sector involvement in dissemination will enhance the rapid growth of the solar PV technology in Ghana (Atsu *et al.*, 2016).

The government of Ghana in its effort to increase the share of renewable energy in the national energy mix has shown commitment through the development of a number of national policies and interventions to provide friendly environment for the development and utilisation of renewable energy. These policies are outlined in a number of policy documents prepared by the Ministry of Energy, Energy Commission, National Development Planning Commission, and Parliament. Notable among such policy documents are the Strategic National Energy Plan (SNEP, developed in 2006), The National Energy Policy and its corresponding Energy Sector Strategy and Development Plan (both developed in 2010), and the Renewable Energy Act (passed by parliament in 2011). The Ghana Shared Growth and Development Agenda, a national development plan by the National Development Planning Commission, also emphasise the role of renewable energy in national development. These policy documents have shown the path government intends to chart with regards to renewable energy and support schemes available to drive the process. This study therefore dissects national policies to determine the likely evolution of government policy direction towards new renewable energy (RE) technologies such as Solar OPV as well as determine the prospects and challenges for solar OPV development in Ghana from the perspective of stakeholders.

2.1 Methodology

This section of the study was prepared using two main approaches: desk study and interview of key policy makers and other experts who have followed events closely in Ghana's energy sector.

The desk study included a comprehensive literature review on a range of issues regarding solar energy policies and support schemes as well as related issues in Ghana. The desk study was undertaken through extensive literature review from the following sources, among others:

- Ghana's Renewable Energy Law
- The National Energy Policy
- The Energy Sector Development Strategy
- The Strategic National Energy Plan
- Ghana Shared Growth and Development Agenda
- Other Energy Policy Documents
- Official reports from relevant organizations

The desk study was complemented with interviews of selected policy experts aimed at having in-depth discussion on Ghana's future direction regarding solar energy and technologies. Twelve (12) experts were interviewed (see Appendix 1). The interviews were conducted using a semi-structured questionnaire. The questionnaire was designed to elicit information on:

- Current development of solar PV and current trends of solar PV utilization in Ghana
- Future prospects for solar energy in Ghana, especially in relation to Ghana's Renewable Energy Law
- Prospects for solar components assembly and manufacture and efforts to attract businesses
- Possible benefits for manufacturing businesses
- Prospects for Ghana becoming a components supply hub for the West African Region
- Possible incentives for manufacturing businesses in the solar energy sector
- Likely foreseen barriers in the manufacturing and sale of solar PV
- Any intention to restrict solar products to some specific technologies?

2.2 Policy support for OPV development in Ghana

The Strategic National Energy Plan (SNEP)

The broad objective of SNEP, with regards to renewable energy, is to accelerate the development and utilisation of renewable energy and energy efficiency technologies so as to achieve 10 percent penetration of national electricity and petroleum demand mix by 2020 (Energy Commission Ghana, 2006). SNEP was prepared to guide investments from 2006 to 2020. Electricity from renewables is expected to come mainly from solar, but also from other notable sources such as wind and biomass. To increase access to electricity in rural areas, SNEP has targeted a 15% penetration of rural electrification by decentralised renewable energy complementation by 2015 expanding to 30% by 2020 (Energy Commission Ghana, 2006). This target was not achieved (RE penetration is less than 1% at present) which indicates that the policy implementation has not gone as planned. This development indicates that there is room for the development of renewable energy including solar PV in order to achieve the set target in 2020. Part of the measures to achieve this target is to ensure availability of less expensive solar modules and other related equipment, largely through the provision of an enabling environment to ensure local production of solar equipment so as to ultimately reduce prices of these products.

The SNEP acknowledged that initial high costs of solar PV have been a major barrier to their widespread deployment. The policy therefore brought forth some recommendations to enhance the development of renewable energy. It was recommended to, introduce government subsidises and provide import duty and tax exemption for renewable energy equipment, appliances and system component. These recommendations were later considered in the renewable energy act of 2011. Currently, importers in Ghana enjoy a 'zero' import duty on solar panels and complete solar systems. The policy also indicated the need for government to support the promotion of local manufacturing of renewable energy devices and equipment in the medium-to-long term. These targets and recommendations stipulated in the policy provide grounds for the development of solar OPV and related businesses in Ghana.

Currently, the SNEP is undergoing a review and with government's interest in solar lanterns, manifested in the distribution of subsidised units to remote rural communities, this is expected to be given greater recognition in the revised SNEP. The revised SNEP is expected to present a further boost to the solar energy industry in Ghana. The Energy Commission itself, which prepares the SNEP document, is aiming to facilitate the installation of 200,000 stand-alone solar roof top systems in Ghana in a programme dubbed '200,000 Rooftop Solar Programme'. The first phase of 20,000 has been advertised (see Appendix 2), in which up to 20,000 residential facilities would be assisted with solar panels of up to 500 Wp. The solar panels are paid by the government programme, while the beneficiary would only have to contribute the balance of system and installation costs. This current market development might pave the way for market introduction of new and cheaper technologies in the future.

National Energy Policy (NEP)

The NEP is currently Ghana's national energy policy document, developed in 2010. The NEP aims to create a conducive environment for increased investment in the energy sector in Ghana to create jobs, add value to resources in the country and boost export revenues. One of the important subsectors of this policy is the renewable energy subsector. The goal of this sub-sector is to increase the proportion of renewable energy in the total national energy mix and ensure its efficient production and use (Ministry of Energy, 2010a). This policy, like the SNEP, also identifies the major challenge in solar PV dissemination to be its high cost which makes them uncompetitive to other energy sources. The policy direction is therefore to improve the cost-effectiveness of solar technologies. This is to be done by addressing the technological difficulties, institutional barriers, as well as market constraints that hamper the deployment of solar technologies. The policy also seeks to create fiscal and pricing incentives to enhance the development and use of renewable energy; as well as create favourable regulatory and fiscal regimes and support the use of decentralised off-grid alternative technologies such as solar PV where they are competitive with conventional electricity supply. This is currently being achieved through the removal of import duty on solar equipment. According to the policy document, ***any business in the sector that seeks to reduce the cost of solar modules in particular will be greatly supported.*** With solar OPV expected to be less expensive than existing solar modules in the market, government could under this policy consider providing marketing support for widespread dissemination, especially in locations where stop-gap solutions are needed for only a few years.

The energy sector strategy and development plan

The energy sector strategy and development plan covers strategies, programmes and projects intended to support the realisation of the national energy policy (Ministry of Energy, 2010b). The focus of the development plan is to assist Ghanaian engineers and scientists to research and develop measures to

reduce the cost of renewable energy technologies and provide fiscal, financial and pricing incentives to improve their competitiveness. In addressing the challenges in the solar energy sector, the development plan specifically seeks to promote the exploitation and use of solar energy resources, support the use of decentralized off-grid alternative technologies such as ***solar PV where they are competitive and provide tax incentives for the importation of all equipment used in the development of renewable energy projects.***

Renewable Energy Act (Act 832)

One of the major policy steps taken by government to ensure the development of renewable energy was the establishment of the Renewable Energy Act (Act 832) in 2011. This was a major feat that has suddenly given hope to the country's renewable energy visions of the past and given an impetus to renewable energy entrepreneurs, with a sudden rush to develop projects. The main objective of the RE Act is to provide for the development, management and utilisation of renewable energy sources for the production of heat and power in an efficient and environmentally sustainable manner (The Parliament of the Republic of Ghana, 2011). The objective encompasses the provision of a framework to support the development and utilisation of renewable energy sources and an enabling environment to attract investment in the renewable energy sector. The act also sought to improve access to electricity through the use of renewable energy sources and the building of indigenous capacity in technology for renewable energy sources (The Parliament of the Republic of Ghana, 2011). The key provisions in the RE Act includes:

- Feed-in-Tariff Scheme under which electricity generated from renewable energy sources is offered a guaranteed price
- Renewable Energy Purchase obligations under which power distribution utilities and bulk electricity consumers must purchase some percentage of their electricity from electricity generated from renewable energy sources
- Licensing regime for Commercial Renewable Energy Service Providers (including Independent Power Producers (IPPs), importers and installers), among others, to ensure transparency of operations in the renewable energy industry
- The establishment of the Renewable Energy Fund (RE Fund) to provide incentives for the promotion, development and utilization of renewable energy resources. Money from the fund is to be used to provide financial incentives, capital subsidies, production based subsidies and equity participation, among others

These provisions in the Act during the past few years have been implemented intensively by the energy commission. Feed-in-tariffs for electricity generated from renewables were published by the Public Utility Regulatory Commission in 2013 and revised in 2014. Licensing is ongoing for IPPs to generate power to be fed into the grid. The RE Fund has been set up and taxes introduced on electricity and petroleum fuels to service the fund.

By the year 2020, the government of Ghana expect that 10% of Ghana's electricity generation capacity will come from renewables, equivalent to about 500MW (Ministry of Energy, 2010b). This is in line with projections by the Ministry of Power, which is targeting over 5,000 MW of total installed electricity generation capacity by 2020 (Ministry of Energy, 2010b). In response to this target, renewable energy power providers have been trooping to the country to begin registration processes towards the generation

of power from renewable energy resources. As of February 2016, a total of 80 provisional licences have been issued by the Energy Commission for electricity from renewable energy². Fifty-five (55) out of this 80 are for solar PV alone, with a total capacity of over 3,000 MW. Although only a fraction of this number would get to the construction stage, the numbers show the interest level in the industry after the passage of the Renewable Energy Act. Already two solar projects have been completed, a 2.5 MW grid-connected solar PV plant owned by the state electricity generator, and another 20 MW grid-connected solar PV plant by an IPP.

It is not only large-scale solar applications that have benefited from the act. In the years after the act was passed, the number of small-scale applications of solar PV has been on the rise. Many of the projects have been government- or donor-funded but have created some market components that are meant to boost the market for small-scale solar applications. Recently, the government under the Solar Lantern Distribution Project has begun distributing subsidised solar lanterns to rural off-grid communities to replace kerosene lanterns. The programme is aimed at providing 200,000 solar lanterns in off-grid rural homes over a period of five years. The solar lanterns were designed with mobile phone charging units and are being imported by local companies: Wilkins Engineering and Mono Eco-Green Energy. The project was implemented in three phases. The first phase which took place within a period of 18 months (Jan 2013 to June 2014) saw the distribution of 20,000 high quality solar lanterns of two different models nationwide through a trade-in or subsidy scheme where households in the target communities were required to turn-in their kerosene lantern or pay a subsidized fee in cash for the solar lanterns. The second phase spans a period of two years (2014-2016). The project is to support the establishment of local assembly of solar lanterns with the aim of assembling 50,000 solar lanterns and its subsequent distribution through a 50% grant subsidy package to ensure a sustainable market for solar lantern promotion in the country. The third phase is also to last for 18 months with the aim of distributing 130,000 solar lanterns with a further reduced subsidy.³ The extent to which this project has been implemented with respect to all the three phases is unclear. It has been noted by Amankwah-Amoaha and Sarpong (2016) that any policy towards scaling up of new technologies require training and development of skilled personnel to raise awareness and implement government policy. This is because human resource constraints such as lack of technicians and engineers have the potential of not only derailing scaling-up efforts, but also lead to misallocation of limited resources. In view of this, the second phase of the project is expected to support the establishment of local assembly of solar lanterns through capacity building efforts. Presently, solar lanterns are common on the Ghanaian market, even though they are quite expensive and not very affordable to rural dwellers. Solar lanterns were made popular, somewhat, by the power crisis that gripped the country over the past 5 years or so. With the crisis gradually getting over, the market for solar lanterns in urban communities may dwindle, but opportunities exist in remote un-electrified rural communities for cheaper alternatives as solar lanterns are needed for lighting purposes.

Currently, importers of solar systems enjoy free duty on solar panels/modules and complete solar systems. The only eligibility requirements are for the business to be registered with the Energy Commission and to meet the standards established by the Ghana Standards Authority.

² See <http://www.energycom.gov.gh/index.php/register-of-licenses>

³ See <http://thechronicle.com.gh/replacing-kerosene-lanterns-with-solar-lanterns/>

There are other ongoing efforts that suggest that the Government of Ghana holds solar energy, both small-scale and utility-scale applications, in high regards. Perhaps the largest plan at the moment is the Scaling-up Renewable Energy Investment Plan (SREP) which has received US\$ 40 million funding from the Climate Investment Fund, with total expected funding of US\$ 230 million, comprising the following four project components (Climate Investment Funds, 2015).

1. RE mini-grids and stand-alone solar PV systems: construction of 55 renewable energy-based mini-grids and 35,250 SHS to be installed in 500 rural communities
2. Solar PV based net metering⁴ with battery storage⁵: installation of 15,000 solar PV roof top systems
3. Utility-scale solar PV/wind power generation
4. Technical assistance to scale-up RE: capacity building for key renewable energy players and policy support to the Government of Ghana (GoG)

On the small-scale solar-PV category of SREP, the objective is to encourage sustainable public and private sector investments. The private-public sector led stand-alone solar PV component alone would lead to the installation of 20,500 stand-alone systems for households to serve an estimated 106,600 people using a partial subsidy and credit facility. In addition, there would also be installation of 1,350 stand-alone systems for schools to serve some 243,000 students, installation of 500 stand-alone systems for health centres and 400 stand-alone systems for communities to service an estimated 215,000 people.

Ghana Shared Growth and Development Agenda

The Ghana Shared Growth Development Agenda (GSGDA II), for 2014 to 2017, was prepared by the National Development Planning Commission to provide a consistent set of development policy objectives and strategies to advance a better Ghana agenda in coming years. It follows on the heels of GSGDA I, which run from 2010 to 2013. The policy direction towards renewable energy particularly in the medium-term is focussed on increasing the proportion of renewable and other sources of energy in the supply mix, particularly solar. GSGDA II aims to accelerate the implementation of the 87 provisions of the Renewable Energy Act by promoting local manufacture of solar and other renewable energy equipment in order to improve the cost-effectiveness of solar technologies. In reality, GSGDA is aiming to implement plans and programmes penned down in the policy documents discussed above without presenting any new information.

Other policy documents and initiatives that can support OPV development

Apart from the national policies and initiatives that targets the development of solar energy one other important organisation that can foster solar OPV technology diffusion in the country is the Association of Ghana Solar Industries (AGSI). AGSI is made of solar industry entrepreneurs and companies, experts and other stakeholders who provide a joint forum for discussion of current solar industry issues. It is open to

⁴ Under Ghana's Net Metering Code, for every kWh that the Customer-generator exports in excess of its consumption it would receive a credit of 1 kWh in the billing period. For each billing period, the Distribution Utility shall carry over any excess kWh credits earned by a Customer-generator and apply those credits to subsequent billing periods to offset the Customer-generator's consumption in those billing periods until the end of the Calendar year. All taxes, levies and charges approved by the Public Utility Regulatory Commission shall be paid by the Customer-generator based on its total electricity consumption. Excess kWh credits shall not be used to defray any fixed monthly Customer charges or levies or taxes. Excess kWh credit accrued to the Customer-generator at the end of one calendar year shall lapse.

⁵ Battery storage may be needed to ensure that a household is able to receive power from the solar PV installation should the grid be turned off, for whatever reasons.

members in the solar industry and businesses that seek to promote renewable energy in Ghana. The association aims to raise the profile of the solar industry, improve quality of design, installation, maintenance and to develop standards within the industry. In order to help consumers decide on a reputable supplier for solar energy, AGSI has implemented a certification system namely: certified solar equipment provider and certified solar service provider (AGSI, 2014). The association also foster the relationship between the government and the private sectors in the solar business. Due to internal conflict and disagreement among members of AGSI, another association, Renewable Energy Association of Ghana (REAG), has been formed by breakaway members, also to promote solar and other renewable energy types in the country. AGSI has been in existence for a lot more years and presently has greater recognition among stakeholders.

Institutions mandated in the RE Act to promote renewable energy utilisation

A number of institutions have been mandated in the Renewable Energy Act to ensure the development of renewable energy in Ghana of which solar energy is a critical component. The existence of established institutions in charge of renewable energy creates a conducive environment and boosts confidence for the private sector. One critical institution, with regards to the solar OPV value chain, is the Energy Commission which is mandated to create a platform for collaboration between government and the private sector and civil society for the promotion of renewable energy sources. The Energy Commission can continually and when necessary recommend tax exemptions for customs, levies and other duties, equipment and machinery necessary for the development, production and utilisation of renewable energy sources. In this regard any solar OPV local manufacturing or importation is likely to receive the necessary tax exemption in order to ensure smooth operation. Other notable duties of the Energy Commission stipulated under the Renewable Energy Act are to promote the local manufacture of components to facilitate the rapid growth of renewable energy sources. The commission is also responsible for licensing all businesses that import, design, install and carry out maintenance on renewable energy systems⁶.

Another notable institution is the Ghana Standards Authority which is responsible for ensuring that imported and locally manufactured renewable energy equipment are up to international standards. Current standards for solar PV devices in Ghana are in line with those by the International Electrochemical Commission (IEC). The standards in place now include IEC 62093:2005; BS EN 60335-1; and GS 536:2002⁷. Once the standards have been met, certification is done by the Energy Commission.

2.3 View of solar energy stakeholders in Ghana

The second section of the study was to ascertain the prospects and barriers for the development of solar OPV from the perspective of stakeholders (see Appendix 1 for list of stakeholder's interviewed). This section employed the use of semi structured questionnaire (see Appendix 3) to interview respondents. Overall twelve respondents were interviewed.

Enabling framework and market actors

Interviewees were of the view that solar may become the most developed RE technology in Ghana due to the fact that the resource is readily available throughout the country⁸ and policy support for solar is

⁶ Register of installation and maintenance license holders can be found at <http://www.energycom.gov.gh/index.php/register-of-licenses>

⁷ Personal communication with Mr Frederick Ken Appiah, Principal Programme Officer at the Energy Commission

⁸ Unlike other RE resources such as mini-hydro and wind, the sun shines everywhere.

greatest within the RE sector. The ease of installation and versatility of solar technology for various applications; off-grid (lighting and charging of mobile phone, water pumping and heating, etc.) and mini grid systems gives it the added advantage to other RE technologies. Even though the levelised cost for solar energy appear to be the highest among the various RE technologies, evident by Ghana's feed-in-tariff policy, government has the interest to develop solar energy which is evident in the various policy documents and plans available. Only one of the interviewees indicated that, despite the abundance of solar resources coupled with its ease of installation and versatility, hydropower could become the most developed RE technology in Ghana due to the greater potential for high capacities/installation, compared to solar technologies.

Interviewees highlighted the fact that there was currently no trade regulations that hinders the import of any solar product or component so far as it meets standards set by Ghana Standards Authority and Energy Commission. They were of the view that while this is good, it has challenges for the local manufacturing business due to their inability to compete with low prices of imported products, especially those from China. For local businesses in the manufacturing industries to develop, the government may have to consider putting some restrictions on the importation of some of these products. Interviewees noted that businesses that seek to venture into the manufacturing and local assembly of solar products are not likely to be restricted by government. Ghana's trade regulations encourage fair competition. As a matter of fact, there are regulations that encourage the local assembly of solar systems. This has been on the agenda of government and is spelt out in several policy documents. These initiatives on the part of government prepare the ground for the development of local businesses that seek to locally assemble these products. One interviewee expressed concern that the lack of clarity on tax exemption for import of raw materials for local assembly/production may hamper the local assembly of these products. This can increase the production cost of these products and correspondingly the selling price. As stated earlier, the Energy Commission has the mandate to recommend tax exemptions in such cases but these are done on a case by case basis.

Wilkins Engineering and Deng Limited were identified to be the market leaders for the marketing of solar lanterns, chargers for mobiles phones and solar home systems. These products were predominantly identified to be imported from China and in some few cases European countries (Spain and Germany). Apart from these companies, others identified to be importers of these products are AEKO solar, Solar for Ghana, TradeWorks, Sunergy Ghana, Kumasi Institute of Technology, Energy and Environment (KITE) and Azure technologies.

Local production, assembly and industry development

According to interviewees, the prospect of solar component assembly and manufacturing business in Ghana is high. The higher prospects were attributed to the large market share it holds and market availability for these products. Policy makers, who were interviewed, indicated that government has keen interest in local assembly of solar products. It was indicated that once a certain volume of solar systems can be assembled locally, tax would be imposed on imported solar systems in order to boost the local industry. At the same time, locally manufactured panels would be exempt from taxes. This can significantly increase the prospects of local manufacturing businesses as their main challenge is competition with cheap imported products. Notwithstanding these prospects, concerns were raised on businesses not surviving the lower prices of imported products without government support, especially in the early years. There were also concerns about the poor performance of Ghana's manufacturing sector generally, which could affect the solar equipment manufacturing sector as well if planning is not properly done. The sector appears to be dying off gradually, perhaps due to the flexible importation systems. Interviewees were aware of plans past

and present, for local solar product assembly. They revealed that two companies: Deng Limited and Wilkins engineering began manufacturing solar modules and lanterns, however, they were unable to compete with lower prices of imported products from China and suspended manufacturing. These two companies targeted the small-scale market due to limited capacity. The technologies targeted were predominantly solar lanterns and panels. TradeWorks, Halo and Strategic security systems are also now putting up local assembly plants.

Theories of innovation would prescribe that new technologies such as PV develop in a niche for small scale products and that the technology gradually develop to broader and more competitive markets. In this context this would imply that there is a linkage between the PV markets for solar lanterns, solar chargers, solar home systems and large grid-connected systems. Interviewees were asked to rank, on a scale of 1 to 5 (5 being the most likely), if there is a linkage between these markets in Ghana (see results in Figure 2.1). Interviewees had a mixed view on the linkages between the three markets, with a relatively equal distribution between the answers. 25% saw a high degree of linkages while about 20 % saw little or no linkages between the three markets.

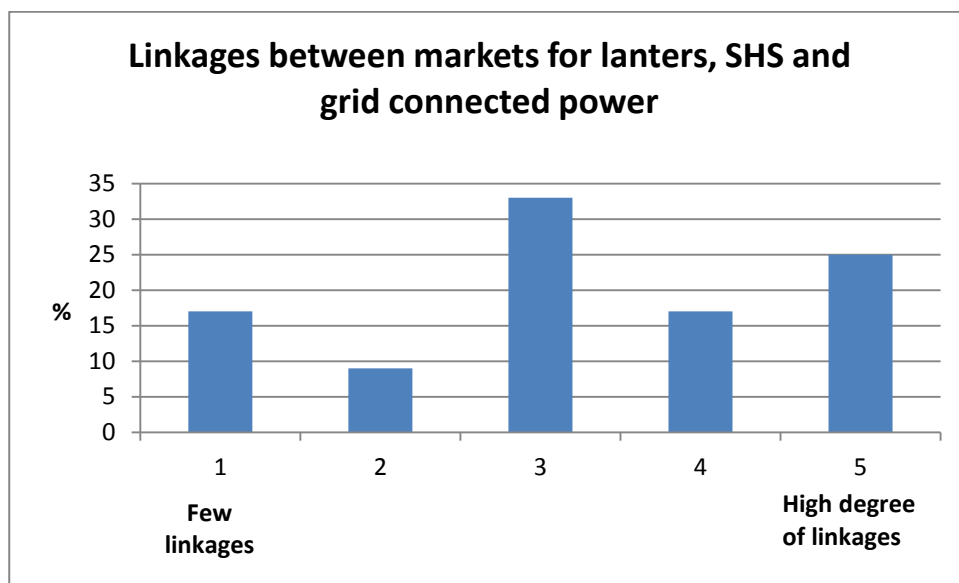

Figure 2.1: Linkage between markets for lantern, SHS and grid connected power

Interviewees agreed that large grid connected systems are politically acceptable in Ghana (see Figure 2), mainly because such systems have worked in several other countries and because there are several installations in gigawatt scale in place, and less because there is experience with and trust in PV in Ghana. Notwithstanding the ongoing development of large-scale grid connected systems in Ghana (over 25 MW installed so far and others in the pipeline), interviewees were of the view that local knowledge played little part in these systems (see Figure 2.3). The lot relied on foreign expertise. For this reason, there is little knowledge transfer and support from large grid connected installations to small scale enterprises. Some interviewees highlighted the issue of little capacity of local expertise.

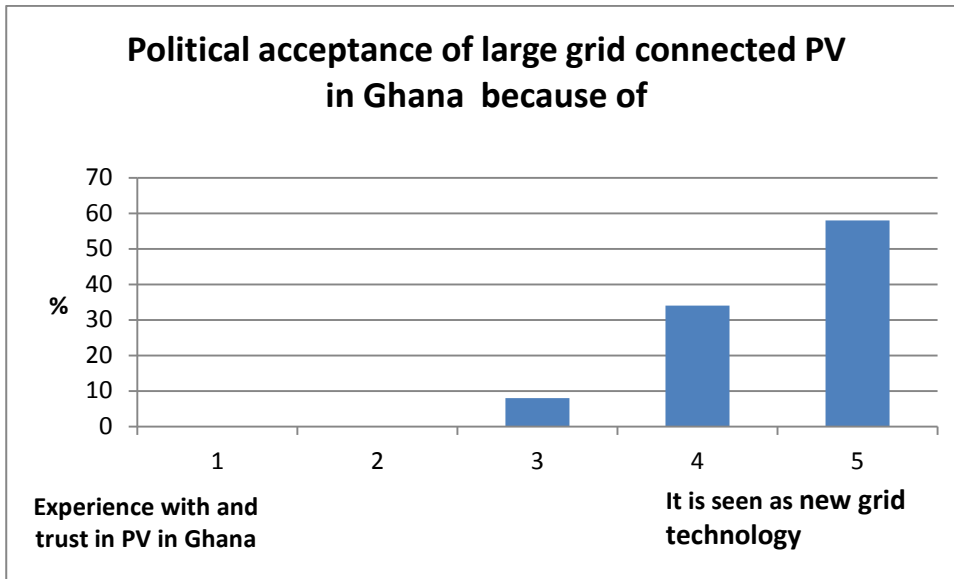

Figure 2.2: Political acceptability of large grid connected PV in Ghana

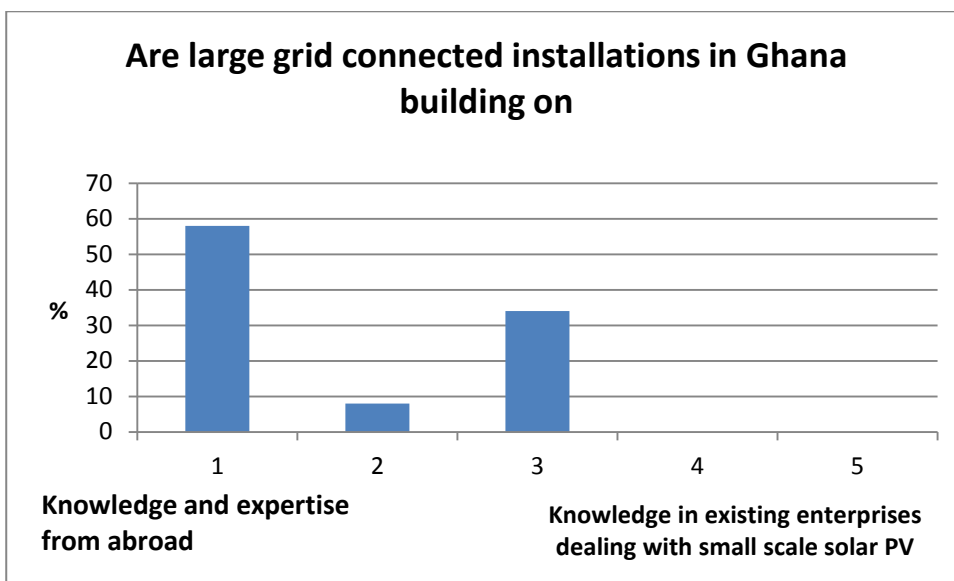

Figure 2.3: Knowledge building by large grid connected installations

Figure 2.4 presents the extent to which large grid connected systems use expertise from Ghanaian universities, engineering expertise and procure material through Ghanaian importers and using Ghanaian skilled personnel with knowledge of PV. The figure shows that for large scale grid connected systems, little expertise is used from Ghanaian universities, and little procurement is done through national Ghanaian importers. It also shows that some but only limited engineering expertise is used, while more skilled personnel with knowledge on PV is used for construction and maintenance.

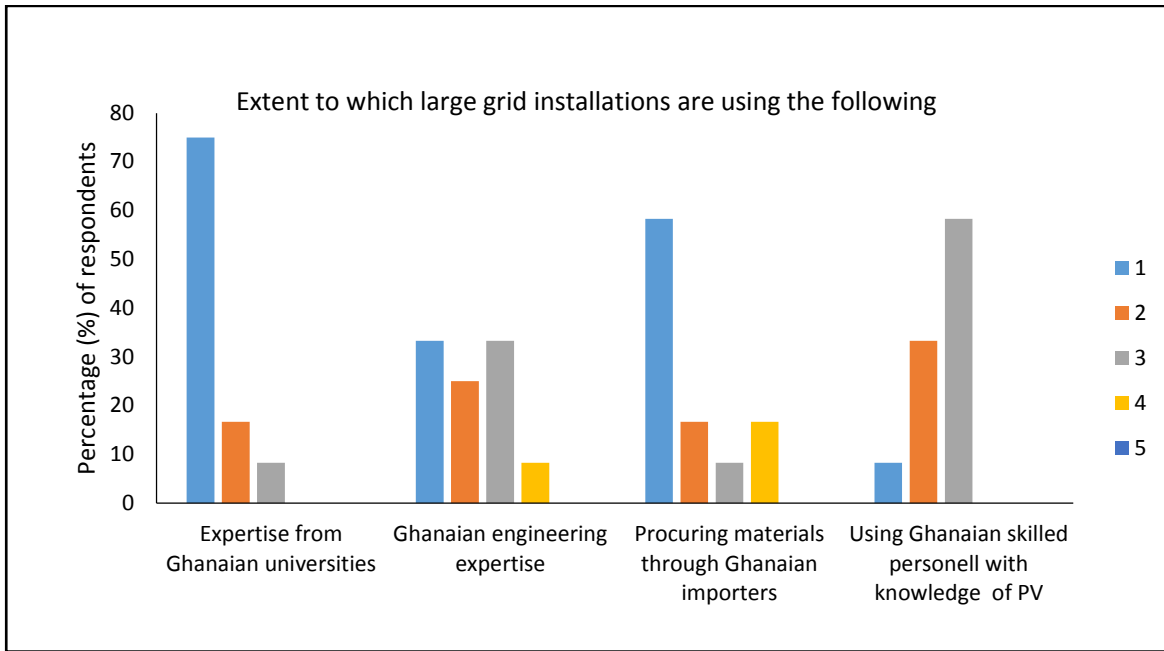

Figure 2.4: Ranking of involvement of local expertise and material for large grid connected installations

The findings from the limited number of respondents above do in general not support the theory that large scale PV develops from the niche of small scale applications and that there are strong linkages between the actors on the market for lanterns, solar home systems and large scale PV installations. It rather indicates that there is a split, especially between the actors on the market for large scale applications and for small scale applications, and that there is relative little interaction in terms of exchange of skills and materials between the two group of actors. This could be explained by the fact that large scale installations are conducted by foreign companies, who bring in capital, expertise and components, and therefore only to a limited degree need local engineering and sub product providers; while they to a larger degree need skilled workers for installation and maintenance.

Technology

Interviewees do not foresee any particular solar PV technology becoming a preferred technology for small-scale applications because there is lack of data to support the technical performance of any of these technologies in Ghana. For these technologies to be accepted, it requires a thorough technical performance data capable of instilling some confidence. For small-scale applications, interviews were of the opinion that smaller and easy to afford systems, like solar lanterns, have the highest prospects in Ghana followed by others such as DC fans and solar water pumping, depending on affordability. Some interviewees think that the Renewable Energy Act 832 supports new PV technologies that are still under development while others were not aware of the subject.

Solar OPV

Knowledge of OPV among policy makers and experts in the sector is very high. Three quarters of the interviewees were aware of solar OPV technology. Some of them have been approached by either a manufacturer or researcher on this technology. Interviewees were of the view that so far as OPV meets all international solar PV technology standards, especially those adopted by the Ghana Standards Authority, it will be strongly accepted by policy makers in (see Figure 2.5). Most interviewees agreed that there is no

reason for solar OPV not to be accepted if it meets the standards. Some interviewees were a little cautious, raising concern about cost. To them, it may not be patronised by consumers if it is too expensive, in relation to efficiency. Interviewees generally asserted to the fact that solar OPV has a higher prospect for small scale applications, which could aid in its acceptance and patronage across Ghana. Its flexible nature gives it an added advantage in terms of developing applications such as solar bags, shirts and cladding of buildings among others. From policy makers' perspective, the government has no intentions to restrict solar products to any specific technology, meaning it is highly unlikely that in the future trade regulation could restrict solar OPV technology.

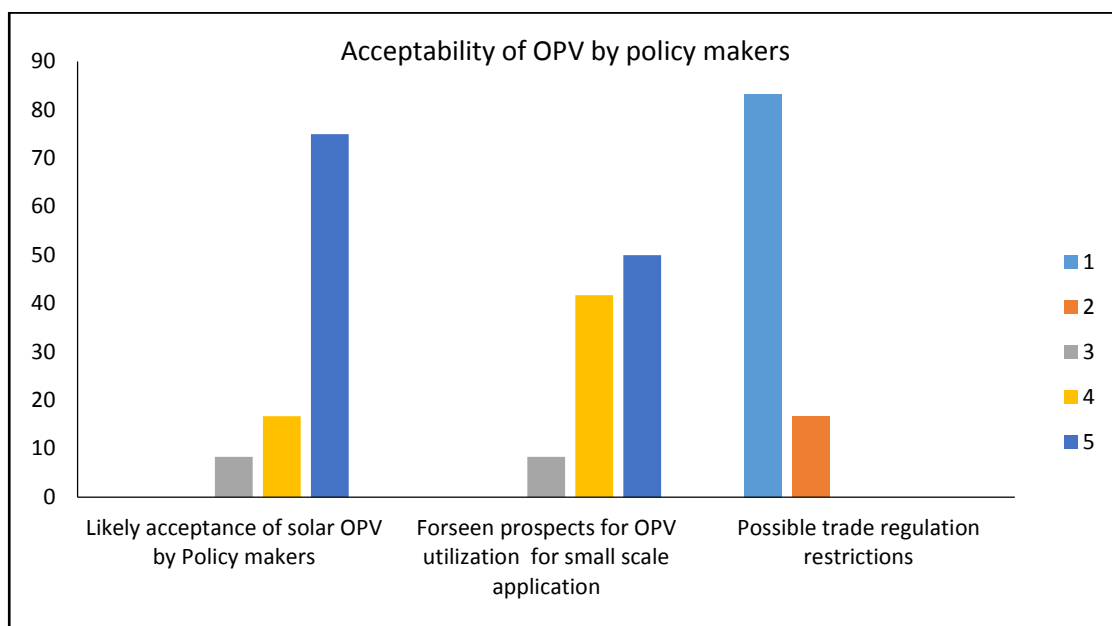

Figure 2.5: Solar OPV acceptance, its use for small scale application and trade regulation restrictions

Barriers and enablers of solar OPV

All the policy makers indicated that government will accept a manufacturer who intends to set up a solar OPV manufacturing plant in Ghana provided the product is of good quality. Government also has no intention to restrict the export of solar OPV if it were manufactured in Ghana. As a matter of fact government would want to make Ghana the manufacturing hub for solar products in the West Africa region and beyond. Interviewees indicated that tax incentives and waving of VAT to encourage new ideas such as solar OPV is possible and Ghana has a technology transfer law that protects investors and Ghanaian entrepreneurs. Ghana's technology transfer regulation (LI 1547) was approved in 1992 as a legislative instrument enforceable by the Ghana Investment Promotion Centre (GIPC) and provides guidelines for both the investor (the transferor) and the local agent (the transferee) in matters regarding transfer of technology to Ghana (GIPC, 1992). The RE master plan (which is being developed) may also support solar OPV with incentives as well as the local content bill. With regards to solar OPV component that can be tax exempted, interviewees indicated that if the company is setup under the free zones enclave, it stands to benefit from a number of financial and non-financial tax exemption for up to 10 years; but then most of its products must be exported. There are other tax breaks for locating the manufacturing plant outside of

Accra the capital city. Tax exemptions on RE technologies are handled on a case by case basis. The Energy Commission has the mandate to recommend tax exemptions under the renewable energy law. From the perspective of interviewees, foreseen challenges for solar component assembly and manufacturing businesses in Ghana may include:

- Competition with cheap products from China
- Very limited market
- Low income level leading to low patronage, i.e. because of the lower income level of Ghanaians the local market for solar PV equipment may be small for manufacturing businesses, especially considering economies of scale. For this reason, a manufacturer may have to plan to target external markets as well
- High capital for investment and awareness creation
- Unavailability of skilled personnel
- Lack of access to long term credit and
- High cost of local production

2.4 Conclusion

It is clear from the review of policy statements and also from the perspective of stakeholders that Ghana's energy plans and policies are conducive for the introduction of solar OPV technology in Ghana. It is not expected that any regulation would hinder the manufacture or importation of solar OPV products. The most critical aspect is for any solar OPV business, whether imported or locally manufactured, to meet local standards and go through the right registration processes. It must be noted, however, that most government programmes are aimed towards ultimately, a local manufacture of solar components in the country and this would be given favourable consideration. A possible hindrance to adopting solar OPV technology on the part of consumers is the currently low awareness of the technology. Clearly, not many Ghanaian consumers are aware of the potential opportunities and economic benefits offered by solar OPV and this could derail uptake. To pump up interest, a serious awareness campaign would have to be undertaken that spells out the unique benefits of solar OPV technology, and an assurance of its operability in Ghanaian communities.

Update

In order to comply with ECOWAS regional policy, tariff incentives on solar products and components were removed in January 2016. The import tariff on all goods, including solar products and components, is now 22% in addition to 17.5% VAT. This policy change affects the cost of solar products and reduces adoption levels.

References chapter 2

- The Parliament of the Republic of Ghana (2011). The Renewable Energy Act 832. Accessed on 15th January, 2016, Available from the internet- [http://energycom.gov.gh/files/RENEWABLE%20ENERGY%20ACT%202011%20\(ACT%20832\).pdf](http://energycom.gov.gh/files/RENEWABLE%20ENERGY%20ACT%202011%20(ACT%20832).pdf)
- Ministry of Energy Ghana (2010a). National Energy Policy, Accessed on 10th January, 2016. Available from internet- <http://www.mofep.gov.gh/sites/default/files/pbb/ENERGY%20POLICY-%20February%202013,%202010%20FINAL.pdf>
- Ministry of Energy (2010b). Energy Sector Strategy and Development Plan, Accessed on 11th January, 2016. Available from internet- <http://ghanaoilwatch.org/images/laws/energystrategy.pdf>
- Energy Commission Ghana (2006). Strategic National Energy Plan 2006-2020, Accessed on 5th February, 2016. Available from internet- <https://s3.amazonaws.com/ndpc-static/publication/Strategic+National+Energy+Plan+2006-2020.pdf>
- Government Of Ghana National Development Planning Commission (NDPC) (2014). Medium-Term National Development Policy Framework Ghana Shared Growth and Development Agenda (GSGDA) li, 2014-2017. Accessed on 4th January, 2016. Available from internet- <https://s3.amazonaws.com/ndpc-static/CACHES/PUBLICATIONS/2015/09/30/GSGDA.pdf>
- Association of Ghana Solar Industries (AGSI) (2014). Objectives and aim of the Association. Accessed on 16th January, 2016. Available from internet-<http://www.ghanasolarindustries.com/>
- Ahiekpor, J. C. (2013). Solar Lantern Projects in Ghana: An Overview. Final Draft Report prepared for the Netherlands Development Organisation (SNV)
- Amankwah-Amoah, J., & Sarpong, D. (2016). Historical pathways to a green economy: The evolution and scaling-up of solar PV in Ghana, 1980–2010. *Technological Forecasting and Social Change*, 102, 90-101.
- Atsu, D., Agyemang, E. O., & Tsike, S. A. (2016). Solar electricity development and policy support in Ghana. *Renewable and Sustainable Energy Reviews*, 53, 792-800.
- Climate Investment Funds (2015). SREP Investment Plan for Ghana. Available from https://www-cif.climateinvestmentfunds.org/sites/default/files/meeting-documents/srep_13_4_srepinvestment_plan_for_ghana_0.pdf
- Steel W.F. et al. (2016). Developing rural markets for solar products: Lessons from Ghana, *Energy for sustainable development* 31, 178-184.
- Forson, F. K., Agbeko, K. E., Edwin I. A., Sunnu, A., Brew-Hammond A. and Akuffo, F. O. (2004). Solar Energy Resource Assessment for Ghana, *Journal of Ghana institute of engineers*.
- GIPC (1992). Technology Transfer Regulations, 1992. Available from <http://www.gipcghana.com/press-and-media/downloads/forms.html?download=26:technology-transfer-guidelines>

3. The market for small-scale solar PV in Sub-Saharan Africa

Given the increasing globalised markets for small scale PV appliances, this chapter provides a review of the current and the future market for small scale PV in a Sub-Saharan African (SSA) context. This chapter is based on a desk top review of information regarding the general status and emerging trends in the market for small-scale solar PV applications in SSA with a 3-5 years horizon. Sources of the review include: donor reports, consultancy reports, industry reports, media, national and regional market surveys, and media coverages available at the internet. The most central source for this chapter is the 'Off-grid solar market trends report 2016', which was published by a cooperation consisting of Bloomberg New Energy Finance, the World Bank, IFC and the Global Off-grid Lighting Association in February 2016 (Orlandi et al., 2016). This literature is supplemented by academic analysis mainly published as journal articles, working papers and conference papers.

Given Organic Photovoltaic (OPV)s comparative advantages with respect to small scale applications, this chapter will not focus on large scale grid connected PV (see e.g. (Hansen et al., 2014)), or larger PV systems for institutions or companies, but will mainly focus on small systems for individuals to be used at the household level or as portable applications. As illustrated in Figure 3.1, this market can be divided into: i) Solar Portable Lights (SPL) or solar lanterns, which are lighting and mobile phone charging applications, ii) Solar Home Systems (SHS), which are used by households to power multi-light sources and smaller appliances, and iii) larger SHS, which are able to service higher electricity demand, including fans, television, freezer and other household appliances. SHS to be used in developing countries are normally in the range of 5-100 W_p (Orlandi 2016).

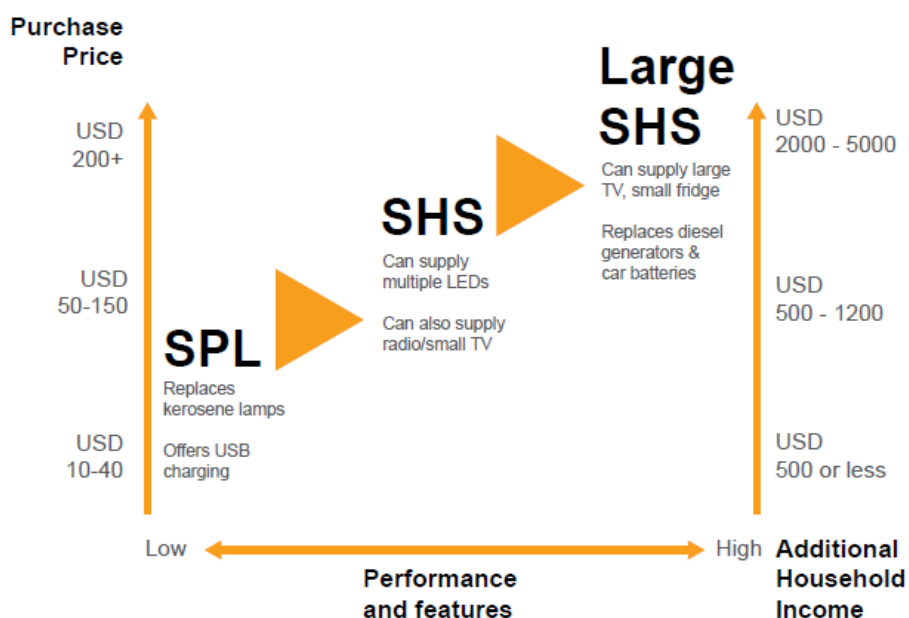

Figure 3.1: Three categories of solar off-grid lighting products, source: Hagan et al. (2015) based on A.T. Kearney and GOGLA (2014)

Lighting Africa initiative (see below) uses the notion pico-solar products for all systems that are less than 10 W_p . A few years ago, pico-solar products were mainly Solar Portable Lights, but due to the emergence of energy efficient lighting alternatives, especially the Light Emitting Diodes (LED) lamps and energy efficient LED based television sets, there is currently a number of small SHS on the market in the range of pico-systems (5-10 W_p), which are providing the same services as much larger solar home systems did only 10 years ago (Hansen et al., 2015; Orlandi et al., 2016).

3.1 Market development for small scale solar power

General market development for PV

While the potential of PV for power generation has long been acknowledged, it is only recently that the economics of PV have been improved to the extent that, under good conditions, it reaches grid parity (Bazilian et al., 2013). As we shall see in the following, this development is mainly due to increases in oil prices and decreases in PV module prices.

As Figure 3.2 below shows, an almost stable oil price of around 20-4 USD per barrel from 1986 to 1999 has gradually increased and from 2007-2015 reached a new - although strongly fluctuating - level averaging 100 USD per barrel. The oil price has since 2015 dropped to a new level and while the future oil price is likely to increase, it currently about 40 USD/barrel⁹. The relatively long period with high oil prices has been important for the market development for PV in SSA, and worldwide as we shall see below.

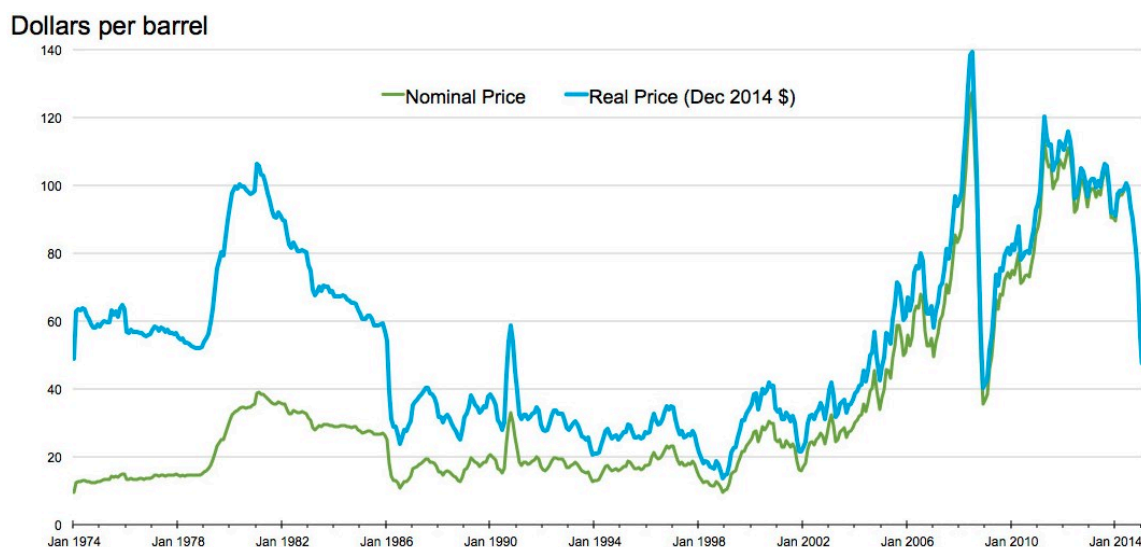

Figure 3.2: Monthly imported crude oil price (US\$ per barrel) 1974-2015, source: (Gongloff, 2015)

At the same time, as shown in Figure 3.3, the price of PV modules has been reduced continuously since the 1990s, and after a period of relative stagnation and momentary price increase during 2003-2007, module prices dropped dramatically from 2008 onwards.

⁹ <http://www.nasdaq.com/markets/crude-oil.aspx> (accessed 18.04.16)

During the period from the early 1990s to the early 2000s, the price of PV modules was gradually reduced in line with the general increase in global PV production and installed capacity (see Figures 3.4 and 3.5). These PV cost reductions resulted from process efficiency improvements and scale economies to reduce manufacturing costs in cell and module production plants located mainly in China and Taiwan (Jäger-Waldau 2013). From the early 2000s and until 2007/2008, PV module prices increased due to a shortage of polycrystalline silicon on the market. This spurred large-scale investments in increasing production capacity in the polycrystalline silicon and PV production supply chain, mainly in China. However, following the financial crisis in September 2008 and later closure of e.g. the Spanish Feed In Tariff program, these investments in expanding production facilities led to a substantial global overcapacity in PV cell and module production (Bazilian et al., 2013). This overcapacity is a key element in explaining the rapid drop in PV module prices from 2008 onwards, since it led to significant price pressures along the entire PV value chain as a result of cut-throat competition among module suppliers and further improvements in economies of scale (REN21 2013). Nevertheless, as illustrated in the learning curve in Figure 3.3, prices are expected to continue to fall, although at a slower rate in the near future (Frauenhofer ISE, 2015).

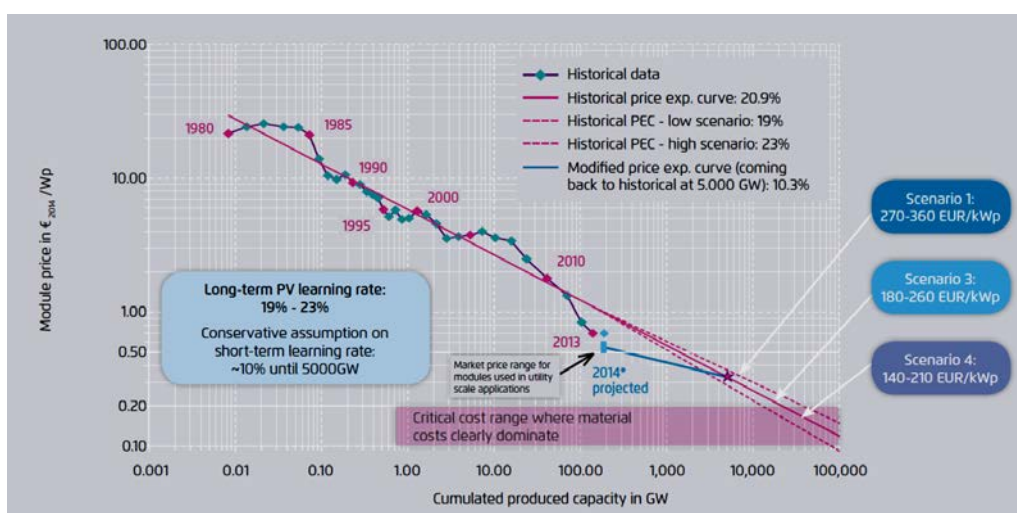

Figure 3.3: The PV module price learning curve for crystalline silicon modules, source: (Frauenhofer ISE, 2015)

Experiences with Solar Home Systems in Sub-Saharan Africa

Solar home systems have been promoted by governments and development organisations in SSA countries since the 1980s; and until 2010 the market remained restricted to telecommunication systems and mainly donor funded projects. A few countries, though, facilitated SHS to individual households: in Kenya through a mainly private sector led model and in Morocco and South Africa through a utility model (Nygaard and Dafrallah, 2015; Nygaard, 2009). For a discussion of the different delivery models for solar home systems in various SSA countries in the past, see e.g. (Nygaard, 2009; Nygaard et al., 2015). The approximate numbers of SHS installed in SSA in 5 selected countries in SSA in 2013 is shown in Figure 3.6, along with a number of other development parameters (Nygaard et al., 2015).

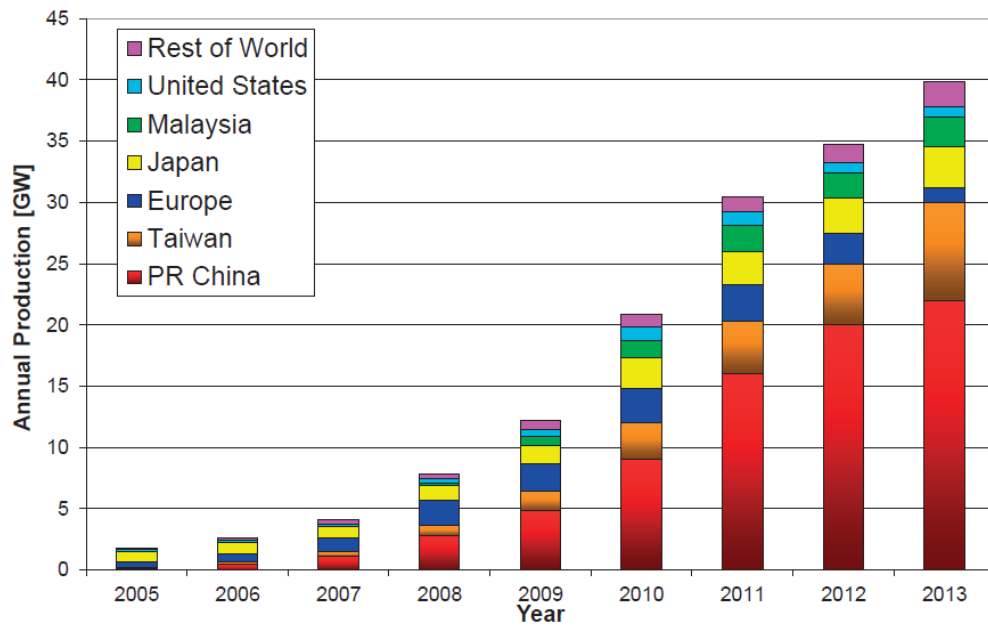

Figure 3.4: Global annual PV production (GW_p) by country and region 2005-2013, source: (Jäger-Waldau, 2014).

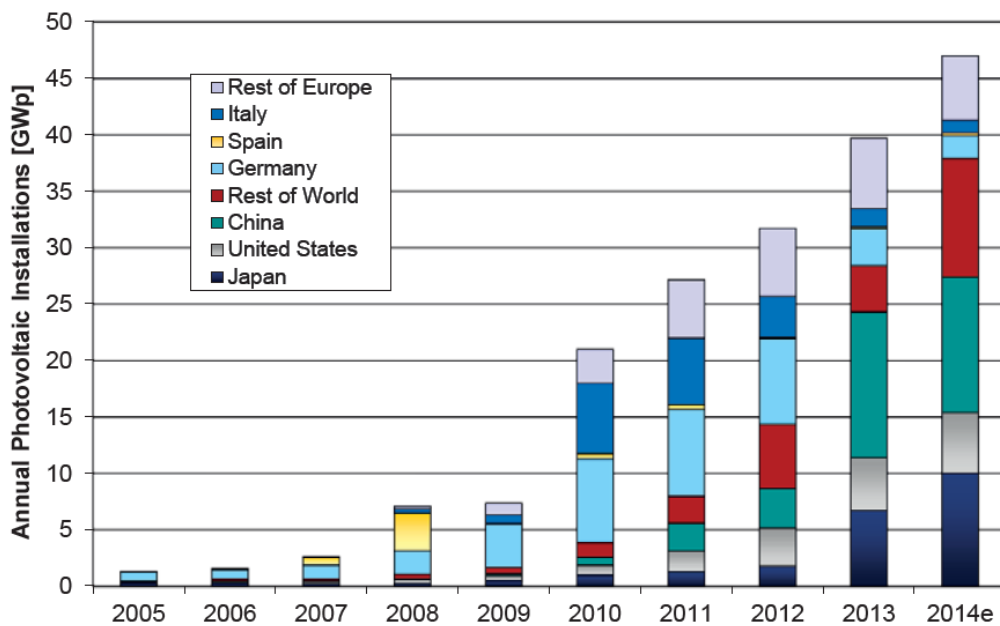

Figure 3.5: Annual PV installations (GW_p) by country and region 2000-2014, source: (Jäger-Waldau, 2014).

	Cote d'Ivoire	Kenya	Mali	Morocco	Rwanda	Senegal
Population, millions (2011)	20.2	41.6	15.8	32.3	10.9	12.8
GDP per capita, USD (2011)	1195	808	684	3105	583	1119
National electrification rate (2011)	59.0%	19.0%	27.1%	99.0%	16.0%	57.0%
Rural electrification rate (2011)	32.0%	7.0%	14.9%	97.0%	5.0%	33.0%
Mobile phone subscription (2011)	86%	68%	68%	113%	41%	73%
Installed PV capacity MWp (2009)	NA	6-8 MWp	10 MWp	> 9 MWp	< 1 MWp	2.3 MWp
Installed PV Wp/capita	NA	0.168	0.388	0.279	0.091	0.180
Installed PV capacity MWp (2012)	NA	16 MWp	15 MWp	NA	> 2 MWp	2.9 MWp
Installed SHS total (2009)	NA	300,000	100,000	> 50,000	NA	22,000
Installed SHS total (2012)	NA	320,000	130,000	> 50,000	NA	22,000
Local assembly of panels (size)	None	2.5 MWp/y	None	None	None	25 MWp/y
FiT	None	2008/2012	None	None	None	TBI
Exemptions from import duty	(Panels)	1990	1999	NA	None	TBI
Exemptions from VAT	NA	1990	2009	NA	(LED only)	TBI

Source: Authors' compilation based on Taoumi (2008), Hankins, Saini, and Kirai (2009a), Hankins, Saini, and Kirai (2009b), SIE-Mali (2009), ONE (2010), SIE-SENEGAL (2010), DNE (2011), Ondraczek (2011), Maïga (2012), Nygaard et al. (2012), Sarr et al. (2012), ONE (2012), WB (2012), Republic of Rwanda (2013), IEA (2013), Jacobsson (2013), Meza (2013), SIE-Mali (2013), SIE-SENEGAL (2013), Da Silva (2014), Ondraczek (2014).

Note: TBI: to be implemented; NA: data not available.

Figure 3.6: Installed solar PV capacity in 2009 and 2012 in six African countries, source: (Nygaard et al., 2015)¹⁰

According to a study based on data from the earlier stages of market introduction of PV system in 2001-2003, prices were at the time higher in Africa than in other parts of the world. High African prices were mainly due to taxes and to high transactions costs in the process of delivery. Therefore, as shown in figure 3.7, there was important differences among African countries, depending on tax levels, sales volume and retail market structure (Moner-Girona et al., 2006)

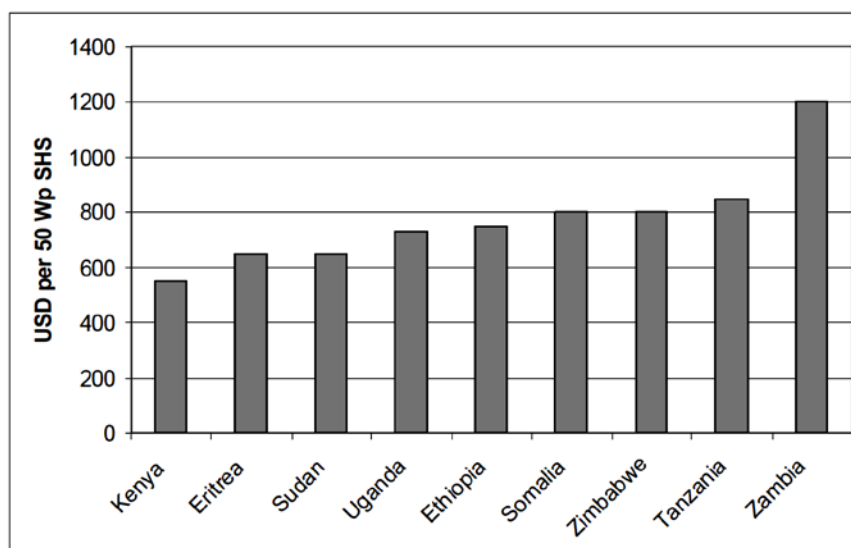

Figure 3.7: Comparison of retail prices of a 50 W_p SHS including panel, four lights, charge controller, installation material and installation in the period from 2001-2003, source: Elaborated by authors based on Moner-Girona et al. (2006)

¹⁰ FiT is Feed-in-Tariff, which was introduced in Kenya in 2008 and revised again in 2012

Price differences among SSA countries are still very much the case, but the general price level has been seriously reduced. To give an example, the Kenyan M-KOPA pico SHS, see figure 3.8, consisting of 8 W_p panel, 3 LED lights, battery, charge controller, a small radio and a rechargeable LED torch provides an even better service (radio and torch) as the above mentioned 50 W SHSs did in 2001-2003, but its retail price is 180 USD, or about 27 % of the price of systems in Kenya 15 years ago, when inflation is taken into account.¹¹ Included in this price is also a prepayment controller including a SIM card, which allows for intelligent Pay-As-You-Go (PAYG) service (Faris, 2015; Fox, 2015)¹².



Figure 3.8: 250,000 units of the pico systems from M-KOPA have been sold in Kenya, Tanzania and Uganda over the last three years, source: M-kopa: <http://www.m-kopa.com/products/>

This price reduction, in combination with the PAYG system, seems to have reached the level, which makes it attractive to a large share of the Kenyan population living outside grid-connected areas. The company behind M-KOPA, which started in 2012, has during the last three years sold more than 250,000 systems to consumers in Kenya, Tanzania and Uganda (Faris, 2015). This is comparable to the 350,000 SHS systems, which were sold in Kenya during the last 30 years.

According to Orlandi et al. (2016), one trend in the market is a movement towards larger SHS, which can provide energy for a fan, a television set or even a small refrigerator. Due to increased efficiency of the appliances, such as for example the market introduction of the 10 W LED TV, power ratings of systems providing the same services have been reduced. This combined with cost reductions for all SHS components has reduced the system cost for a SHS including lamps, radio and TV set from 991 USD to 354 USD during the period from 2009 to 2014. This development is expected to continue, and according to Orlandi et al. (2016) the price for the same system is expected to be reduced another 50 % in the coming 5 years, reaching 193 USD per system. The experienced and predicted cost reduction of separate system components are illustrated in Figure 3.9.

It is important here to add that according to Orlandi et al (2016), the cost of 3 to 50 W_p solar panels are experiencing a slower cost reduction measured in USD/W_p as for larger modules (250 W_p), which are dominating the market for large grid-connected systems and for roof top installations in Europe and

¹¹ $180 / (580 * (\text{USD inflation rate } 2003-2016 = 1.31)) = 27\%$ (source: Moner-Girona et al. (2006); The inflation calculator <http://www.westegg.com/inflation/infl.cgi>)

¹² <http://www.m-kopa.com/products/>

elsewhere. This is because there is a minimum unit cost for frames, lamination, soldering, etc, which are independent of the size. When in figure 3.9, we see large reduction in retail price on the PV panel; it is partly due to a reduction in size from 121 W_p to 27 W_p made possible by more efficient appliances. The system in Figure 3.9 provides four hours of light, four hours of television, six hours of radio and 1 telephone charge per day. Further assumptions regarding the retail price estimations for 2009 and 2014 are available in Phadke et al. (2015)¹³, and projected price reductions until 2020 are based on projections in (Global LEAP, 2016).

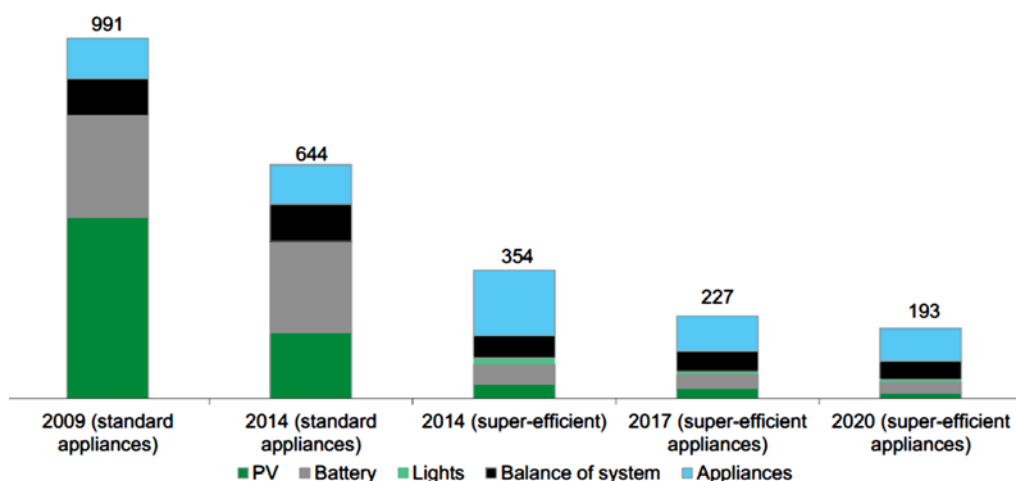

Figure 3.9: Retail prices of SHS with 19" TV, radio and lights (USD/unit), source: (Orlandi et al., 2016)

Experience with pico solar products in Africa

The new trend is the rapid expansion of the market for pico systems for lighting and battery charging. So far the majority of the pico market is in the category of solar portable lights, including options for mobile phone charging, but as mentioned above the pico-market also increasingly include multiple light products, normally called SHS, such as e.g. the M-KOPA illustrated above.

The World Bank Initiative, Lighting Africa, has initiated a voluntary global certification scheme for solar lighting products, which currently comprises more than 48 pico solar lighting systems and 6 SHS. More information of the certification scheme is presented in section 1.5, and a full illustrated list of certified products is attached as Appendix 2 to this document. The lighting Africa initiative and the certification scheme have provided a unique opportunity for collecting statistical information of the sales of certified products in Africa. Figure 3.10 shows the estimated number of 'branded' pico-solar lighting products in Africa of which so far the vast majority are simple lanterns. The figure shows that there has been a significant increase in the sales of branded pico-products since the start of the certification scheme in 2010. The reduction in first half of 2015 is by Orlandi et al. (2016) explained by constraints in finance and supply chains, but also as a possible sign of increased competition from non-branded products. As of 2015, Orlandi et al. (2016) estimate that generic products comprising 'no-names, copycats and counterfeits, account for at least half of the pico-solar market'.

¹³ The retail cost was assumed to be twice the FOB wholesale cost based on the typical markup and duty and tax rates across African countries indicated in the Lighting Africa Market Trends Report 2012 (Lighting Africa, 2013).

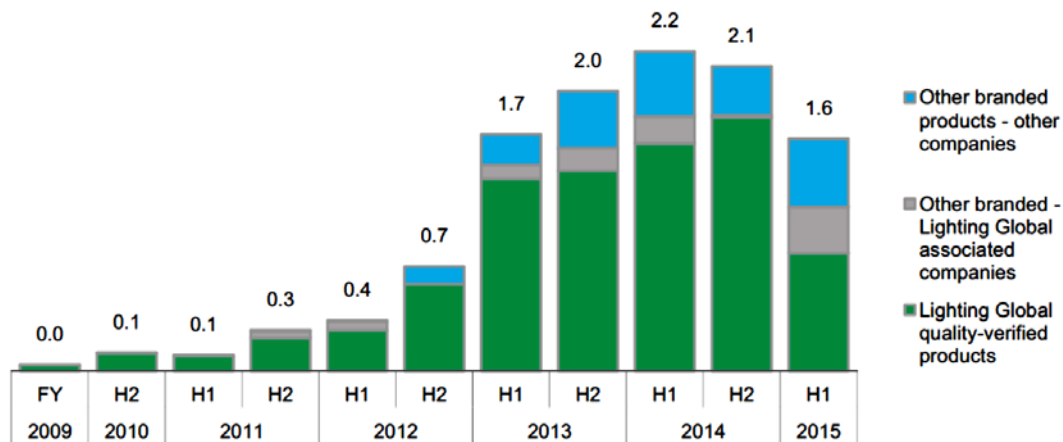

Figure 3.10: Sales of branded pico-solar lighting products in Africa (million of units), source: (Orlandi et al., 2016)

About two third of the quality-certified products have been sold in East Africa in Kenya, Ethiopia and Tanzania. The sales of Lighting Global verified products for different countries in Africa are shown in Figure 3.11.

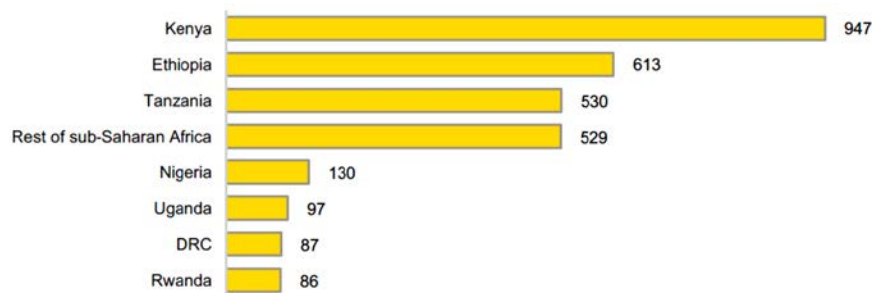

Figure 3.11: Reported sales of Lighting Global quality-verified pico-solar products in SSA in H2 2014 and H1 2015. (thousands of units), source: (Orlandi et al., 2016)

The dramatic increase in of sales in Kenya alone is shown in Figure 3.12, which also indicates the start and end of a consumer awareness campaign financed by Lighting Africa.

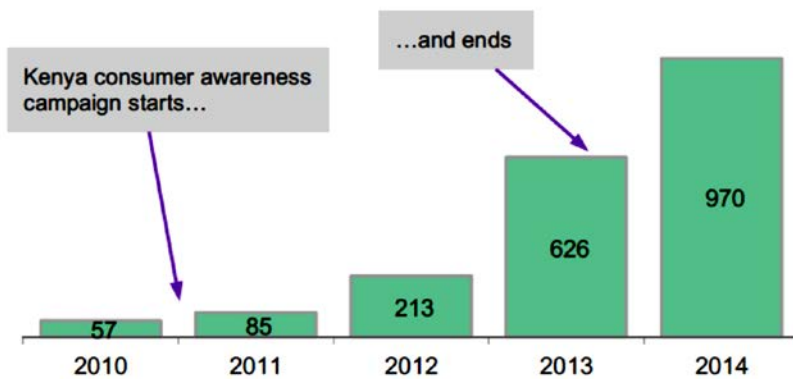

Figure 3.12: Sales of quality-verified products in Kenya (thousands), source: (Orlandi et al., 2016)

The retail prices of pico-systems are as low as 5 USD per unit and according to Orlandi et al (2016), 59 % of all pico-solar unit sales have a retail price below 20 USD. Retail prices are varying from country to country due to differences in competition and market volume, but also to a large extent on the products sold on different markets. Figure 3.13 shows the average retail price of pico-solar products in second half of 2014 and first half of 2015 in the three countries. The difference among Kenya and Tanzania, is by Orlandi et al (2016) explained mainly as a difference in products sold. While demand in Tanzania is mainly for simple lanterns, the demand in Kenya has to a large extent been the high end products below 10 W_p, such as the M-KOPA system at a price of 180 USD.

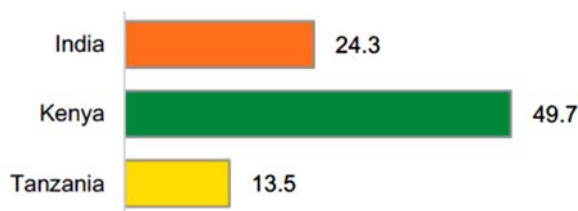

Figure 3.13: Average retail price of pico-solar products, H2 2014-H1 2015. (USD/unit), source: (Orlandi et al., 2016)

3.2 Emerging business and delivery models of solar applications

In SSA, where diffusion of SHS until recently has been supported by donor organisations, 5 different delivery models have emerged as illustrated in Figure 3.14. These models spans from a donation model with 100 % subsidy to a fully commercially led, cash sale model, with no subsidies involved. In between these extremes is the multi stakeholder delivery model, in which the end user is the owner of the installation, while the sales are facilitated by a donor financed support program set addressing actors in the local value-chain, and providing subsidy and affordable credit to end-users or the retailers. Another widespread delivery model is the fee for service model, according to which the Energy Service Company or the Electric Utility remains the owner of the system and sells electricity to the consumers on a monthly basis. (Nygaard, 2009)

<i>Model</i>	<i>End-user</i>	<i>Ownership</i>	<i>Financing provided by</i>	<i>Subsidy level for investment</i>	<i>Responsible for installation, maintenance and after sales service</i>
Donation	Institutions	End-user	Donor	High, 100 %	End-user, committees
Commercially led delivery model (cash sale)	Private	End-user	End user	Zero	End user
Multi stakeholder programmatic model (credit)	Private	End-user	Donor, financing institution, dealer, end-user	Low to medium	Depends on circumstances
Fee for service (dealer model)	Private, Institutions	Utility, Energy Service Company (ESCO)	ESCO	Medium to high	ESCO
Fee for service (concession model)	Private, Institutions	Utility, ESCO	ESCO	Medium to high	ESCO

Figure 3.14: Five types of delivery models for solar applications, source: (Nygaard, 2009)

The commercially led delivery model was in some countries, such as Kenya, partly a hire-purchase model where the consumer paid 30 to 50 % up front and payed of the rest to the retailer in instalments within one to two years. Within the last 5-10 years this hire purchase model has evolved into more advanced hire-purchase models, currently known as Pay-As-You-Go (PAYG) models (Rolffs et al., 2015).

One example of a currently successful PAYG model is the model used by SolarNow in Uganda. SolarNow sells modular SHS where the consumer starts out with a simple system for lighting and adds on more power packages along with more appliance packages, such as a TV and a refrigerator. 35 percent is payed up front and the rest is payed back in 24 monthly instalments. The company is operated through 45 franchises allocated in smaller towns spread over the country. The franchisee is responsible for collection of the monthly instalment and the repair under the two years warranty period. This model is based on presence and on a personal contact with the consumer (source: Interview in Jan. 2013, <http://www.solarnow.eu/>)

Another example is the Kenyan registered company M-KOPA, which was introduced above. The system, with a retail price of 180 USD, is delivered upon a 35 USD initial payment and the rest is payed via the Kenyan developed mobile payment service, M-PESA. M-KOPA uses the latest technology for ensuring payment and has included a SIM-card in the device. This means that the consumer will have light as long as he is in advance in payments, which is around 0.40 USD per day. In this case the cost of light becomes divided into the smallest units possible, light or power for the mobile phone for the current day. Repayment rates are high, and M-KOPA has attracted the needed capital for expansion in Kenya and to other countries in the region (Fox, 2015).

The two examples, M-Kopa and SolarNow can be identified at the lower and the upper end of the product in Figure 3.15, which shows main PAYG service providers and their product range in W_p .

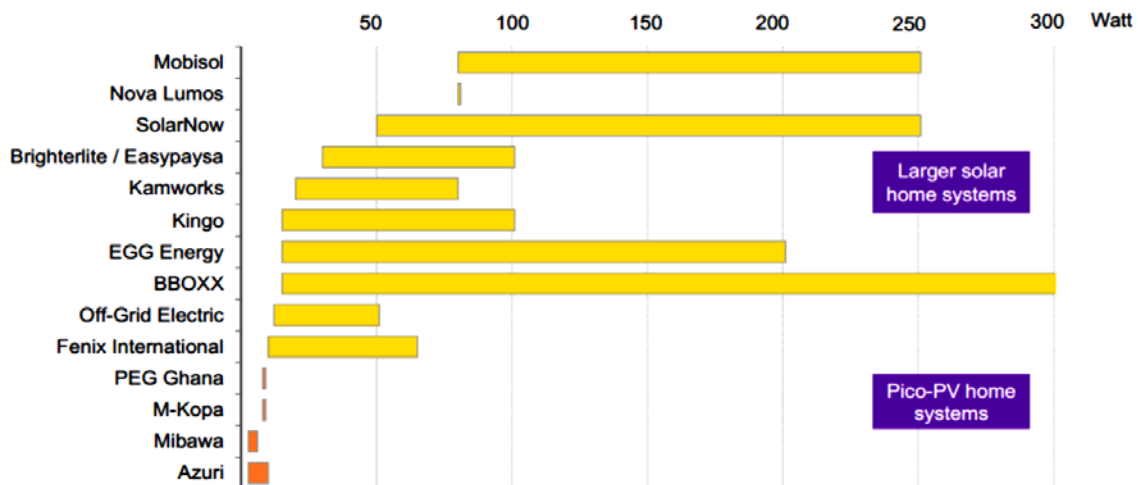

Source: Bloomberg New Energy Finance, company reports and websites, media reports.

Figure 3.15: Available PAYG service providers in Africa, source: (Orlandi et al., 2016)

PAYG services started in Kenya and are currently most common in Kenya, Tanzania, Rwanda and Uganda, but they are rapidly spreading to other African countries. According to Orlandi et al. (2016), Azury systems are present in many countries and companies like Nova Lumos, PEG Ghana (an M-KOPA franchisee) and Oolu Solar are preparing for market expansion in Nigeria, Ghana and Senegal. A recent report issued by lighting Africa notes that although PEG Ghana (the third largest business in pico solar in Ghana) currently uses PAYG services. The limited spread of mobile payment technology in Ghana may still hamper the spread of pico-solutions in Ghana. (Andrew Scott, Johanna Diecker, Kat Harrison, Charlie Miller, 2016). As of late 2015, the availability of PAYG portable lights and SHS in various African countries is shown in Figure 3.16.



Source: Bloomberg New Energy Finance. Note: The list represents a sample and does not claim to be comprehensive.

Figure 3.16: PAYG lighting services (portable lights and SHS) currently available, source: (Orlandi et al., 2016)

3.3 Regional industrial actors on the SSA market for lanterns and chargers

The manufacturers of solar lanterns and chargers have increased rapidly over the last 5 years. As shown in Figure 3.17 the number of 'known' manufacturers has increased from 15 in 2010 to 105 by 2015.

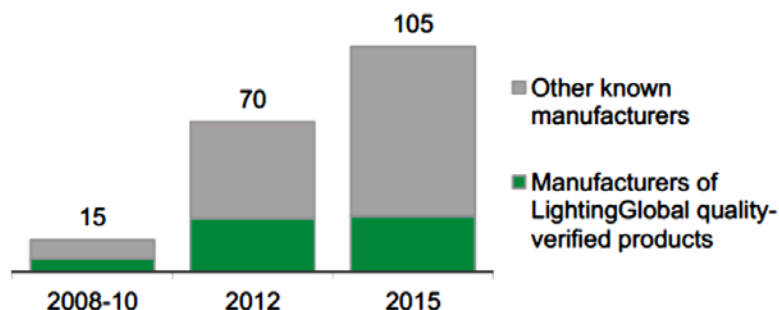
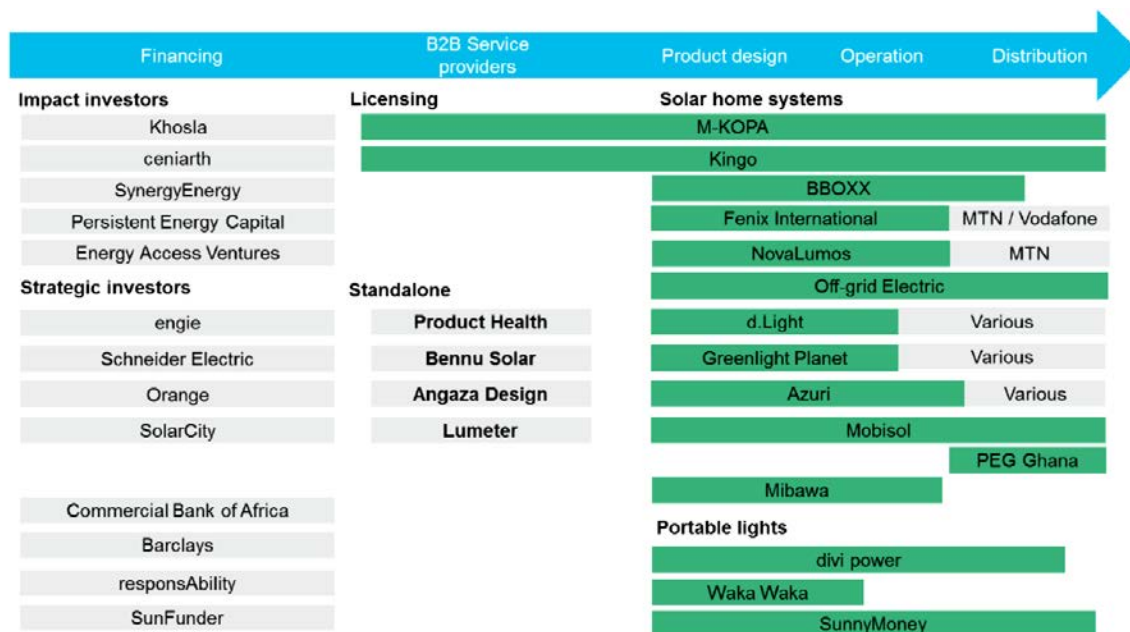

Figure 3.17: Number of 'known' pico-solar manufacturers, source: (Orlandi et al., 2016)

Figure 3.18 shows how market actors for each brand can be described according to different categories, such as financing (asset holders), service providers, product design, operation and distribution. Some companies, such as M-KOPA control the whole chain, while PEG Ghana being a subsidiary of M-KOPA is only involved in distribution. Others, such as AZURI financed by the Telecompany Orange, use various distribution companies for reaching the customers.



Source: Bloomberg New Energy Finance. Note: the list of companies is neither complete nor representative.

Figure 3.18: Sample of PAYG market actors along the value chain, source: (Orlandi et al., 2016)

Solar home systems

Below is a short description of a few selected companies providing solar home systems. Information is mainly extracted from company webpages, and should therefore be taken with caution.

Mobisol -Kenya and Tanzania

German start up in 2011 operating in Kenya and Tanzania (Woodhill, 2013). Mobisol is now East Africa's largest rent-to-own solar service provider by capacity installed and a reputable company with 185 permanent employees and over 200 freelancers in Tanzania. Mobisol has so far electrified over 35,000 households in East Africa and has installed more than 3.5MW solar capacity. After having successfully installed 35,000 live systems in Tanzania and Rwanda and having proven the feasibility of the concept, Mobisol is now moving into the business at a larger scale. The system is available in three different sizes between 80 and 200 Watts. The systems can illuminate entire households and power e.g. laptops, radios, TVs, fridges and charge cell phones. The larger systems are powerful enough to run energy-based businesses. (KPMG ECO, 2016). Mobisol's Lighting Global certified 80 W_p solar home system is illustrated in Appendix 2

SolarNow, Uganda¹⁴

Operations started in Uganda in May 2011, building on management's 7-year experience with the Rural Energy Foundation ("REF") training hundreds of rural entrepreneurs across Africa to develop solar energy enterprises and recognizing the potential in Uganda to develop a scalable commercial business.

According to the webpage, SolarNow has since sold 10,000's of Solar systems on a two year hire purchase agreement including 24 months service, warranty, credit & protection plans from 2100 UGX (0.62 USD)¹⁵ per day. Sales and maintenance is operated through franchises situated throughout the country. Client repayment performance is good with low delinquencies and minimal write offs.

Solar Works, South African¹⁶

Solar Works from South Africa is an example of a business model to reach middle class homes. It includes 5 lights in exclusive and elegant design (1.2 W, 120 lumen/lamp), battery and light switches. Solar Works are on the list of lighting global certified products (see Appendix B)

Lanterns and chargers

Below is a short description of a few selected companies providing Pico-systems. Information is extracted from company webpages should be taken with caution.

M-KOPA¹⁷

M-KOPA is already described briefly above. The case is well described in the African Business magazine (Fox, 2015) and Bloomberg Business News (Faris, 2015), and the background development trajectory for the company is well described in Rolffs et al. (2015)

Barefoot¹⁸

The Barefoot power products are designed in Australia to provide durable, convenient and reliable lighting and charging solutions for households and businesses without reliable access to electricity at affordable

¹⁴ <http://www.solarnow.eu/>

¹⁵ <https://www.oanda.com/currency/converter/> (19.04.16)

¹⁶ <http://solar-works.co.za/products/solar-home-system#specifications-technical-data>

¹⁷ <http://www.m-kopa.com/products/>

¹⁸ <http://www.barefootpower.com/index.php>

prices. According to the company webpage, Barefoot Power products have provided light to 2 million people in 22 countries.

The Barefoot power products are certified by the Lighting global. The Barefoot connect is a pico-size SHS, with mobile charging options. The Firefly series are portable lighting and phone charging solutions.

*Azuri*¹⁹

Azuri's HQ is in Cambridge, United Kingdom, with staff based in Kenya, Uganda, Ghana, Ethiopia and Tanzania and presence in 11 countries across sub Saharan Africa.

A customer purchases via scratch card or mobile money, either once a week or once a month, and adds credit to their unit via a mobile phone. The unit automatically shuts off on a time basis. Over the course of typically 18 months, the purchase of top-ups allows the system to be paid off and the customer can choose to either unlock their Azuri system forever or upgrade to a larger model.

Azuri's models are certified by Lighting Global and shown in Appendix 2.

3.4 Global standards, regulation and support programs - lanterns and chargers

The most prominent support program for lanterns and lightings on the SSA market is the program Lighting Africa, which was established by the World Bank in 2007 with the objective to 'supporting the global lighting industry to catalyse a robust market for off-grid lighting products tailored to the needs of African consumers.' (Lighting Africa, 2009)

Lighting Africa started by running its first pilot projects in Ghana and Kenya in 2007 and is currently working in 11 countries: Burkina Faso, the Democratic Republic of Congo, Ethiopia, Kenya, Liberia, Mali, Nigeria, Senegal, South Sudan, Tanzania and Uganda and has plans to extend activities to the rest of the continent. Lighting Africa is run under the umbrella, Lighting Global, which also covers Lighting Asia and Lighting Pacific. Lighting Africa is supported by a number of bilateral donors, among those, Denmark.²⁰

Lighting Africa has sought to 'accelerate' the off grid market in Africa by i)addressing policy and regulatory barriers, ii)creating partnership with financing institutions, iii) establishing product quality assurance, iv) creating business to business linkages and v) by providing market intelligence and market information. For this report we see tangible results in terms of supply chain mapping studies from West African countries such as: Burkina Faso (Chabanne et al., 2013), Senegal (Dalberg, 2013a), Mali (Dalberg, 2013b), and policy report notes from Ghana (Lighting Africa, 2012a) and Senegal (Lighting Africa, 2012b)

Since 2009, Lighting Africa and later Lighting Global have managed a quality-assurance programme for Pico-solar products. The main objective of the programme was to protect the consumers by ensuring a baseline level of quality and ensuring truth in advertising. The quality standards comprise the following elements (Lighting Global, 2015a):

Truth-in-Advertising: Accurate consumer-facing labelling (e.g., rated run time, light output battery capacity, PV power).

¹⁹ <http://www.azuri-technologies.com/about-us>

²⁰ <https://www.lightingafrica.org/about-us/>; <http://www.lightingglobal.org/>

Lumen Maintenance: L85 time is greater than 2,000 hours.

Battery: Must be durable and adequately protected.

Health and Safety: Batteries may not contain mercury or cadmium, products are safe.

Durability and Quality: Appropriate protection to prevent early failure.

Warranty: Consumer-facing with at least one year of coverage.

Performance Information: Run time and brightness reported along with a note about the impact of mobile phone charging.

The testing framework developed by Lighting Africa and Lighting Global has been adopted by the International Electrical Committee (IEC) as technical specification IEC/TS 62257-9-5 and has been integrated in national programs in Kenya, Ethiopia, Liberia, Bangladesh and Nepal' (Orlandi et al., 2016). Since 2015 the testing of pico systems below 10 W_p has been supplemented by adding SHS larger than 10 W_p (Lighting Global, 2015b). As of the end of second half of 2015 there were 54 quality-verified products on the list (see Appendix A2.2 or consult the webpage directly at <http://www.lightingglobal.org/products/>).

The Lighting Africa voluntary quality insurance scheme provides an important and much needed standard, which so far has proved to be embraced by about half of the current market for pico-solar products. It favours big transnational companies, which have the resources to develop quality products and make their products go through the testing. A number of countries have tried to set up test stations to ensure quality and performance of imported product and to make them comply with national standards, but with the large number of producers and brands (and no-brands) these intentions at national level have to our knowledge rarely been fulfilled ²¹

Another avenue for standardisation is to go through the regional economic communities. According to Diecker et al. (2016) the West African Economic community, ECOWAS, is 'about to adopt the IEC technical specifications as mandatory minimum quality standards, as a community of states. They further plan to cooperate through joint test laboratories and accepting test results from laboratories within the region, which will help best available technologies spread between countries without new'.

3.5 Differences in market development in East and West Africa

Kenya is seen to be the country in which the PV lighting market is growing most rapidly compared to its neighbouring countries and not least compared to countries in West Africa. The reasons behind the relative success of market development for SHS in Kenya compared to two other East African countries, has been reviewed in Hansen et al. (2015). According to the review donor programs and national policies have used a combination of direct and indirect measures to promote the diffusion of solar PV. The SHS market segment has been supported mainly through indirect measures, such as VAT and import duty exemptions for imported PV components and favourable loan and credit schemes for SHS suppliers and customers, which has also been the case in a number of other countries without the same results (Nygaard, 2009). The review points at five additional factors, related to market formation, the industrial environment and the role of entrepreneurs.

²¹ See e.g. interview on national standards for PV products with SPEC, Uganda, January 2013

An often repeated explanation for the growth of the SHS market segment in Kenya is the general rise of an affluent rural middle class from around the 1990s, which increasingly demanded electricity to power televisions, radios, cell phones and other modern electrical appliances. The increasing incomes from tea-growing were particularly important in improving the purchasing power of these rural customers. This would indicate that, besides the effects of the demand from the rural middle class, the lack of prospects for grid connection was an important factor for customers in deciding to purchase SHS. As illustrated in Figure 3.6, the national electrification rate in Kenya was among the lowest in SSA, only 19 % and the rural electrification rate was only 7 % in 2011.

Byrne (2009) points to the geographical proximity between the PV industry, which is concentrated mainly in Nairobi, and market demand; as the customers, in living mainly on the southern and eastern sides of Mount Kenya, were located relatively close to the suppliers. Indeed he considers the close distance between the PV supplier industry and the end-market to be a key explanation for the initial growth of the commercial SHS market in Kenya during the 1990s.

Hankins (2000) highlights the development of a local battery supplier industry during the 1990s in Kenya as a key factor in accelerating the diffusion of solar PV and in particular emphasises that 'technical modifications, known and utilised in the manufacture of batteries for other applications for years, improved PV system performance'. This signals cross-fertilisation of the technical development mainly of car batteries to suit PV systems and thus a fruitful interaction between two emerging industries in Kenya.

Byrne (2009) also highlights the role of local champions and entrepreneurs. In Kenya, two entrepreneurs Mark Hankins and Harold Burris, already in 1984 founded a small company called Solar Shamba', which had an important influence both at the earlier and later stages of PV market development in Kenya. Burris provided training to local technicians in PV systems as well as preparing various PV-related technical tools and guide books and broader consultancy and promotional activities. Through Solar Shamba' they also engaged in a number of demonstration projects showcasing PV systems in Kenya, which, according to Byrne (2009), was instrumental in attracting interest from donors and the Kenyan government.

Ondraczek (2013), p. 414 ascribed a generally enabling business environment in Kenya a key role in stimulating the SHS market by pointing to 'a strong entrepreneurial culture in Kenya and openness to foreign investors and business practices/ideas', environment in Kenya as a key role in stimulating the SHS market by pointing to 'a strong entrepreneurial culture in Kenya and openness to foreign investors and business practices/ideas', while also deploring that 'the lack of entrepreneurs hindered the emergence of successful solar companies in Tanzania during the 1980s and 1990s.

In conclusion, five key points have been identified in the literature as primary explanations for differences in the diffusion of solar PV in Kenya, Tanzania and Uganda. The first factor identified is the importance of the growing middle class in Kenya. The second and third factors are the favourable geographical conditions and the existence of a local sub-component supplier base, which are related to mobilizing resources. The fourth and the fifth factors are the importance of local champions and of a vibrant business culture in Kenya, which relates to the conditions for entrepreneurial experimentation.

3.6 Conclusion

In SSA, the market for pico-lighting systems for private consumers has within the last 5 years increased dramatically from less than 100,000 units per year in 2010 to more than 4 million units in 2014. This market growth is especially observed in a few countries such as Kenya, Ethiopia, Tanzania and Uganda. The explanations of this development include:

The decreasing cost of PV panels, decreasing cost of system components such as batteries and charge controllers and not least the availability of energy efficient appliances, such as LED lighting, LED television sets, which reduce the need for power and thereby the overall system cost.

Along period of market development of PV products in Kenya supported by various donor programs and made possible by a low electrification rate in combination with middle class consumers living outside grid-connected areas. This has matured the market, stimulated companies' and consumers' trust in PV solutions and in hire purchase arrangements, built technical capacity in small companies for repair and maintenance, and thereby paved the way for large scale diffusion of PV solutions.

The emergence of advanced hire-purchase sales models, so-called PAYG models, which are using mobile payment technologies for daily, weekly or monthly payment of instalments and mobile telephone technology for controlling the devices and turning them off in case of lacking payment.

The emergence of a quality-assurance programme established by Lighting Africa, which has attracted main suppliers of pico-lighting systems to an extent that about half of the market is currently covered by quality-verified products. This has reduced the risk of consumers losing confidence in PV products due to poor quality.

Lighting Africa has facilitated the market development in target countries by financing awareness campaigns stimulating demand and market and policy analysis making the market more transparent for entering market actors and finally, the market increase has provided options to reduce costs by mass-production of technically advanced products mainly from Chinese producers.

The market actors are globally oriented and the development observed in East Africa is expected to spread to West Africa and Ghana within a few years. As a relevant example it could be mentioned that a subsidiary of M-KOPA, the most successful PAYG Company operating in East Africa has recently started operation in Ghana under the name of PEG Ghana. This means that local production of OPV products in Ghana will face and increasingly international competition on small scale appliances, with the possible consequence that protected niches for newly developed appliances will be limited.

The fact that there is a large SSA market for Pico-solar systems in the range from 3-10 W_p provides opportunities for OPV products produced in Ghana, such as e.g. panels for pico-systems (3-10 W_p), but the OPV products have to be competitive on cost and performance in order to penetrate the market. An opening could be as 'non-branded' PV spare parts for defect PV panels in pico-solar systems, substituting more expensive silicon solar cell panels.

References chapter 3

- A.T. Kearney and GOGLA, 2014. Investment and Finance Study for Off-Grid Lighting.
- Andrew Scott, Johanna Diecker, Kat Harrison, Charlie Miller, R.H. and S.W., 2016. Accelerating access to electricity in Africa with off - grid solar. Off - grid solar country briefing : Ghana. Overseas Development Institute.
- Bazilian, M., Onyeji, I., Liebreich, M., MacGill, I., Chase, J., Shah, J., Gielen, D., Arent, D., Landfear, D., Zhengrong, S., 2013. Re-considering the economics of photovoltaic power. *Renew. Energy* 53, 329–338. doi:10.1016/j.renene.2012.11.029
- Byrne, R.P., 2009. Learning drivers: Rural electrification regime building in Kenya and Tanzania. PhD Thesis. University of Sussex.
- Chabanne, A., Dansette, S., Lindner, K., Neebe, M., Siles, B.R., Taylor, H., 2013. Mapping the Supply Chain for Solar Lighting Products in Burkina Faso Final Report. MicroEnergy International.
- Dalberg, 2013a. Mapping the supply chain catering the base of the pyramid in Senegal. Lighting Africa.
- Dalberg, 2013b. Mapping the supply chain catering to the base of the pyramid in Mali. Dalberg.
- Diecker, J., Wheeldon, S., Scott, A., 2016. Accelerating access to electricity in Africa with off-grid solar: Policies to expand the market for solar household solutions. Overseas Development Institute.
- Faris, S., 2015. The Solar Company Making a Profit on Poor Africans. *Bloom. Businessweek* 1–11.
- Fox, B., 2015. Can “ pay as you go ” solar light up rural Africa ? *African Bus. Mag.*
- Fraunhofer ISE, 2015. Current and Future Cost of Photovoltaics. Long-term scenarios for market development, system prices and LCOE of utility scale PV systems, Study on behalf of Agora Energiewende. Study on behalf of Agora Energiewende.
- Global LEAP, 2016. The State of the Off-Grid Appliance Market. Global LEAP.
- Gongloff, M., 2015. Oil Prices Actually Aren't That Low , Historically Speaking. *Huntingt. post.*
- Hagan, E. Ben, Mifsud, O.V., Diecker, J., 2015. Developing Effective Off-Grid Lighting Policy. UNEP.
- Hankins, M., 2000. A case study on private provision of photovoltaic systems in Kenya, in: Brook, P.J., Smith, S. (Eds.), *Energy Services for the World's Poor: Energy and Development Report 2000*. ESMAP, World Bank, Washington, pp. 92–99.
- Hansen, U.E., Nygaard, I., Pedersen, M.B., 2014. Prospects for investment in large-scale , grid-connected solar power in Africa. UNEP Risoe Centre, Copenhagen.
- Hansen, U.E., Pedersen, M.B., Nygaard, I., 2015. Review of Solar PV market development in East Africa. *Renew. Sustain. Energy Rev.* 46, 236–248. doi:10.1016/j.rser.2015.02.046
- Jäger-Waldau, A., 2013. JRC Scientific and Policy Report: PV Status Report 2013. European Commission, DG Joint Research Centre, Luxembourg. doi:10.2790/93822
- Jäger-Waldau, A., 2014. JRC science and policy reports: PV Status Report 2014. European Commission, DG Joint Research Centre. doi:10.2790/941403
- KPMG ECO, 2016. Mobisol – Smart High Quality Solar Solutions for 30 , 000 households in Tanzania.
- Lighting Africa, 2009. Lighting devices test results - Tanzania.
- Lighting Africa, 2012a. Policy Report Note: Ghana. Lighting Africa.
- Lighting Africa, 2012b. Policy Report Note: Senegal. Lighting Africa.
- Lighting Africa, 2013. Lighting Africa Market Trends Report 2012. Lighting Africa.
- Lighting Global, 2015a. Lighting Global Quality Standards. Lighting Global.
- Lighting Global, 2015b. Solar Home System Kit Quality Standards. Lighting Global.
- Moner-Girona, M., Ghanadan, R., Jacobson, A., Kammen, D.M., 2006. Decreasing PV Costs in Africa:

- Opportunities for Rural Electrification using Solar PV in Sub-Saharan Africa. *Refocus* 7, 40–45.
- Nygaard, I., 2009. Compatibility of rural electrification and promotion of low-carbon technologies in development countries: The case of Solar PV for Sub-Saharan Africa. *Eur. Rev. Energy Mark.* 3, 125–158.
- Nygaard, I., Dafrallah, T., 2015. Utility led rural electrification in Morocco : combining grid extension , mini-grids , and solar. *Wiley Interdiscip. Rev. Energy Environ.* 3. doi:10.1002/wene.165
- Nygaard, I., Hansen, U.E., Mackenzie, G., Brix, M., 2015. Measures for diffusion of solar PV in selected African countries. *Int. J. Sustain. Energy* 6451. doi:10.1080/14786451.2015.1086768
- Ondraczek, J., 2013. The sun rises in the east (of Africa): a comparison of the development and status of solar energy markets in Kenya and Tanzania. *Energy Policy* 56, 407–417. doi:10.1016/j.enpol.2013.01.007
- Orlandi, I., Tyabji, N., Chase, J., 2016. Off-grid solar market trends report 2016. Bloomberg New Energy Finance, World Bank, IFC and Global Off-grid Lighting Association. doi:10.1017/CBO9781107415324.004
- Phadke, A., Jacobson, A., Park, W.Y., Lee, G.R., Alstone, P., Khare, A., 2015. Powering a Home with Just 25 Watts of Solar PV: Super-Efficient Appliances Can Enable Expanded Off-Grid Energy Service Using Small Solar Power Systems. Ernest Orlando Lawrence Berkeley National Laboratory.
- REN21, 2013. Renewables 2013: Global Status Report. Renewable Energy Policy Network for the 21st Century (REN21), Paris.
- Rolffs, P., Ockwell, D., Byrne, R., 2015. Beyond technology and finance: pay-as-you-go sustainable energy access and theories of social change. *Environ. Plan. A* 47, 2609–2627. doi:10.1177/0308518X15615368
- Woodhill, J., 2013. Value chain development by the private sector in Africa. GIZ.

4. The Ghanaian market for small-scale solar products

This chapter describes the Ghanaian market for solar products – a market that responds to the present opportunities created by favourable policies, significantly increasing electricity tariffs and a changing of lifestyle to modernity. The methodology used and the key findings are summarized in Table 4.1.

Table 4.1: Overview of methodology used and key findings

Method	Rationale	Target Stakeholder	Key Findings
Open-ended Interviews with policy makers and technocrats in Ghana	To gain insights government expectations, plans and activities related to renewable energy	Policy developers and implementers such as experts at the energy commission	The government is keen on increasing solar adoption and is increasing legislative initiatives to that effect. However, there could be better coordination, collaboration and involvement among government stakeholders especially those who could be key drivers for adoption like the Irrigation Authority, Education, Transportation, Health, Town planning
Interviews with Development partners	To gather information on past RE projects and lessons learned as well as current and upcoming projects	UNDP, SNV,	There are a number of development partner initiatives that are contributing to the growth of the industry (especially in the areas of policy and education). The sector is building momentum but requires innovation in the entire solar value chain including financing, appliances, business models
Interviews with related sector professionals	To understand how professionals are integrating solar in their sectors and the challenges they are facing and project ongoing	Green-building Council Ghana, Institutes of Architects,	Professionals acknowledge the need for solar integration into their work but cite the low adoption rates and client demand. However there are some initiatives on this
Structured Interviews with Solar Household Users	To understand the reasons for solar adoption, challenges and experiences and types of uses	Households in Accra	Most people still see the initial cost as a constraint but more importantly see the opportunities while being weary they may not see the immediate benefits of solar with existing appliances like air-conditioners unless they change to energy efficient appliances as well

Structured Interviews with small retailers of electrical goods	To understand which brands of solar products are supplied by those who sell lights, bulbs and other electrical suppliers. Also to understand quantities sold and gauge interest in OPV	Small retailers of electrical inputs such as wires, bulbs, plugs, lighting, etc.	Current retailers of solar are briefcase small business operators with other day jobs. They are typically acting on behalf of family abroad or as local reps of solar entrepreneurs abroad
Interviews with solar product distributors	To understand the solar market in Ghana and its trends and drivers	Barefoot Solar, Starlight Solar, Greenlight Planet, Wilkins Engineering, Burro Brand	These entities are formal and are relatively large compared to the brief case entrepreneurs. They have more developed commercial systems and have formal relationships with overseas manufacturers.

To date, at least 70% of the sized solar installations, i.e. the ones larger than the pico system, are project funded by the state or development agencies and are done through tender for off-grid rural electrification. Many of the larger players in the market rely on these types of projects to stay afloat, and with an additional income from sales to wealthy urban dwellers and companies. The rural dwellers still find solar products expensive, irrespective of system size, and prefer on-grid electricity to off-grid when given a choice.

There is a need to wean away from development funding to drive the market growth. Efforts by the Energy Foundation and the Ghana Association of Solar Companies in collaboration with the state to drive solar uptake will hopefully bear fruit soon. Some private players are considering new initiatives around financial models. It has been a challenge to finance the start-up cost of setting up a system at the household and business levels. Other organizations are considering working with local distributors or resellers at the village level to extend the distribution. They need to find better business models and packages to offer the market in terms of scope of reach, variety, complementary products, financing options and reach a tipping point.

Over the past years there has been tariff rebates or discounts on solar equipment importations. The aim of this incentive was to encourage consumers to install solar systems and use solar appliances and therefore relieve pressure on the grid. However, during the 2015 energy crisis, many users purchased solar batteries and charged them on-grid, instead of using solar energy. This did not reduce the pressure on the grid, and thus in the newly launched Rooftop Solar Program (see chapter 2) where the solar panel is paid for while the beneficiary have to finance the balance of system components including the battery themselves.

Financing, tariffs, taxation and customs processes are not running smoothly in the present market. In order to comply with ECOWAS regional policy, tariff incentives on solar products and components were removed in January 2016. The import tariff on all goods, including solar products and components, is now 22% in addition to 17.5% VAT. This policy change affects the cost of solar products and reduces adoption levels.

4.1 The actors present in the market

The Ghanaian solar energy sector is dominated by companies working within distribution, system integration, and import of components or appliances such as: lamps, lighting systems, batteries, panels and customize systems for clients. Some focus solely on lanterns and lighting i.e. the pico segment, whereas others distribute larger systems. Some are individual entrepreneurs who solicit orders, import and then link client to an electrician for installation. Important private sector players operating in the market are: *Deng, Wilkins Engineering, Burro Brand, Barefoot Solar, Greenlight Planet, PAYGO, Persistent Energy Partners Ghana (PEG), Starlight Solar, Dutch &Co, Atlas Business & Energy Systems, Aquasaline, Lumentech, Mascot, Mono Eco Green Energy, Novai, Power World, Toyola and T&G services*. Appendix 2.3 gives an overview of products available from retailers in Accra.

There are also numerous solo entrepreneurs in the space. They are mainly focused on providing systems for the pico segment but also larger customized systems and on developing the market for solar products demand and adoption. They are based in Accra mainly and have sub-distributors in the regions and rural areas. The solo entrepreneurs mention high tariffs, inconsistency of customs procedures, low adoption rates and demand, affordability by customers as their challenges.

A number of “briefcase entrepreneurs” are setting up businesses by connecting with family members and friends abroad having some knowledge about solar energy, and based on this try to develop a downstream business. The briefcase entrepreneurs typically do not have registered businesses and have limited, or no, technical expertise. When the solar systems are delivered, the entrepreneur will call an electrician who installs it. There is a lot of activity in this space as these briefcase entrepreneurs are taking advantage of the present opportunities, but their limited training and understanding affects the perception and thus, the uptake of solar energy negatively.

It is surprising and interesting to note that physical retail stores in Ghana selling electrical light bulbs and electronic items, do not stock any solar products. The solar products from these entrepreneurs are often found online because many sellers work out of homes or back offices as a result of the market not being setup properly. There are a few exceptions, especially with the sellers for pico products. Burro Brand is an example of a properly set-up company that sells through retail stores. Burro Brand’s success is linked to the credit they offer to the stores and their providing of some branding and marketing material to the stores.

Private solar businesses serve as suppliers of solar products through competitive bidding or sole sourcing to corporations. We found that most solar business derive most of their sales from stakeholders as government, corporate bodies, NGOs and development partners by providing solar products and services to these entities. There is a lot of secrecy around the sales statistics from distributors locally, and it is highly questionable if one could take procurement by (or through) these developments and CSR²² projects as proxies for the sales in the market. Table 4.2 compares the targeted distribution of lanterns with the achieved distributions in present and recent projects. Included in the table is also the cost per consumer/client and the percentage subsidy per lantern.

²² Corporate Social Responsibility

CONTACT BURRO

0.50.60.70.555
www.burrobrand.biz
www.facebook.com/BurroBrand
www.twitter.com/BurroBrand
info@burrobrand.biz

All Burro products come with:

30

DAY

MONEY-BACK PROMISE

SCAN TO DOWNLOAD THE FULL CATALOGUE

ABOUT BURRO

Founded in Koforidua in 2008, Burro is committed to bringing you high-quality, affordable tools to build a better life. If it doesn't help you to earn more or to save more, you won't find it with Burro. Check out our latest offerings and you'll see why at Burro we say DO MORE.

EASY TO BUY

Burro resellers are located in major cities across Ghana. If your favourite shop doesn't already carry Burro products, please call or text on 0.50.60.70.555 and we'll get you connected.

DEALER OPPORTUNITIES

Burro welcomes qualified dealers. Opportunities remain in several regions. Call or text 0.50.60.70.555 or email dealer@burrobrand.biz

SUPERIOR SERVICE & SUPPORT

We stand behind every Burro product and want you to be completely satisfied with your decision to buy Burro. Most Burro products offer a 30-day money-back promise and a one year warranty. If you are ever dissatisfied with any Burro product, please call us on 0.50.60.70.555 and let us know. We will work with you to make it right.

MONEY-BACK PROMISE

Have an idea for something that would make your life better? Please let us know. Burro wants to hear from you. Email ideas@burrobrand.biz

PRODUCT CATALOGUE

September 2015

Discover Innovative, Affordable Ways to Save More and Earn More

TOOLS FOR A BETTER LIFE™

BATTERIES & CHARGERS

Better Batteries, Lower Cost

Burro began its business with a better battery at a lower cost and continues to offer the best value in quality AA alkaline and rechargeable batteries.

Burro Rechargeable Batteries are the best choice for regular usage of power-hungry devices. Invest in rechargeables now for maximum savings over time.

Choose Burro Alkaline Batteries for dependable power at low, up-front cost. They hold their charge for years and perform like top global brands at about half the cost.

ALKALINE BATTERIES

4 in a pack

3.50

RECHARGEABLE BATTERIES

4 in a pack

34.00

BATTERY CHARGER

22.00

D-ADAPTER

1.50

BATTERY SAVER

1.50

PORTABLE PHONE CHARGER

15.00

POWER BANK 10K

150.00

SOLAR SUPER CHARGER

110.00

SOLAR ECO

775.00

PORTABLE PHONE CHARGER

15.00

SOLAR SUPER CHARGER

110.00

SOLAR ECO

775.00

Figure 4.1: Burro Brand product catalogue, September 2015

Table 4.2: Ongoing and recent projects on distribution of solar lanterns, Source: SNV, Solar Lantern Report 2013

Project	Period	Status	No of lanterns Installed	Project target	Subsidy Amount	Cost per consumer GHC ²³	Capacity (Wp) per unit	Cost of project
GEDAP	2009 - 2014	Active	8,000	7,500	70%	28	2.5	USD 400,000
KLARP (Phase 1)	2013-2014	Active	18,000	20,000	70%	30	2.5	Undisclosed
ALFA	2008-2010	Completed	410	1500	0%	150	6	€ 282,145
One-child-one solar light	2009-2011	Completed	5000	5000	0%	63	1.5	USD 199,720
COCOBOD	2011-2013	Completed	1,200,000	1,200,000	100%	0	0.45	Undisclosed
Cadbury Partnership	2011	Completed	10,000	10,000	100%	0	1.5	USD 600,000
Newmont	2012	Completed	1,225	1,225	100%	0	N/A	Undisclosed
Shell Ghana	2012-2013	Completed	2,000	2,000	100%	0	N/A	Undisclosed
CRAN/Impact Energy	2010-2013		800	20,000	0%	60	1.5	Open market project
Barefoot Power	2011-date	Active	2700	N/A	0%	30 - 80	1-2.5	Open market project
Burro Brand	2010-date	Active	N/A	N/A	0%	30 - 90	1 - 90	Open market project

Various development agencies have supported Ghana in the renewable energy (RE) sector since 1989. They include: UNDP, IDA, Fund from Nordic Countries, Spain & India, DANIDA, CIDA, JICA, KfW, EU, SNV, US Environmental Protection Agency, World Bank and IFC, among others. There are also many NGOs involved in the sector, such as: New Energy, KITE, World Vision Ghana, Rural Energy Foundation, ASA Initiative and Dasgift Quality Foundation, among others. NGOs generally provide the link between end-users and distributors or financiers. Key findings are that these partners continually develop initiatives that shape the renewables and solar energy policy in the country. Other stakeholders operating in the development space are microfinance institutions (MFIs) who participate in delivering renewable energy solutions. Some of

²³ Exchange rate: 1.00 GHS = 0.26 USD

these MFIs include: *Naara Rural Bank, GNADO, Grameen Ghana (GG), First National Savings and Loans Limited (FNSL), Bonzali Rural Bank (BzRB), Borimanga Rural Bank (BRB) and Productive Entrepreneurs in Development (APED)*, among others.

Foundations of private companies and some private companies also support RE initiatives in particular communities as part of their corporate social responsibility agenda. They include: *Cadbury, Ghana Cocoa Board, Newmont and Shell Foundation*. These could be good sources of early adoption and scaling solar enterprises.

4.2 Marketing Strategies

Various marketing strategies are used: radio discussions, house-to-house selling, selling at events such as churches gatherings, workplaces to mention but a few. When products are good, word of mouth is also an important channel. Many larger solar systems come directly from a large firm. The bigger firms market also through their networks and through captured audience events where for instance, they host seminars, invite the firms in the sector and engage them on the relevant issues. They also focus more on consulting, receiving orders and installation like the commercial and industrial levels.

Most distributors have Facebook accounts and raise awareness of their products through it. Companies, like Deng, arrange seminars to engage and train professionals in influential industries (like construction) to raise awareness of their solar products and options. They even use some of their products on their premises to raise awareness. Deng for example uses its water pump to irrigate their office garden. Barefoot Solar and Greenlight engage potential influencers, use radio, produce marketing material and train the distributors in their networks regularly. They also try to come up with new products regularly - better than the previous version. Development agencies like SNV hold exhibitions, fairs and workshops to raise awareness about their products, such as cooking stoves.

Marketing of new products requires awareness campaigns. There are a number of organizations that are involved in the promotion of energy efficiency and renewable energy. Such awareness-raising is the domain of a non-governmental organisation composed of private sector partners like the Energy Foundation, which works closely with the Energy Commission. Private sector players include the Association of Ghana Solar Industries (AGSI) and the Renewable Energy Association of Ghana. We expect that companies in this space spend large sums of money on education to sensitise people about the technology in order to realise purchases.

4.3 Distribution

The type of distribution depends on the set-up of the company. For instance, pico systems do not necessarily use shops; they use distributors from different geographical locations and levels of scope. They have country, regional and local distributors. Generally, the main distributors are located in Accra and the companies have local distributors in specific locations. The main marketing task usually lies with the local distributors and main distributors. They are also the ones to take on most risk in the value chain.

The smaller distributors get training, some business support and buy a certain amount of stock from the main distributor to sell to retailers in their locations. The retailers then sell on to end-users. It has been difficult for these companies to distribute directly through retail because retailers take a bigger share of the revenue and are not willing to make exceptions on VAT exemptions. For example, appliances are VAT-free but retailers will not take it off their systems to avoid messing up their computerized pricing system.

Product distribution is often determined by the sponsor of the project, while the private firms also have their own strategies for distribution, depending on the location and targeted clients; see example of a distribution chain set up for a specific project in Figure 1.

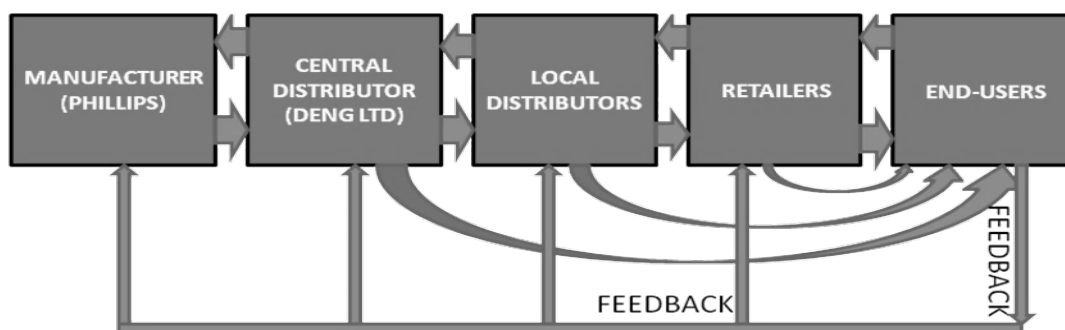

Figure 4.2: The supply chain model used for a project (ALFA) for distribution of lanterns in Ghana

Cost of distribution is very high, and most main distributors do not have a large sales force but rather use local distributors with local networks in their respective locality. They use radio and other media to reach potential distributors who can invest in stock to sell in their area. The main distributor then provides basic training and support (e.g. with marketing brochures). As distribution is costly selecting the right distributor is critical. The criteria list for evaluation of distributors/retailers used in a project for distribution of lanterns (The ALFA project, see table 4.2) serves as a relevant example:

- Must be interested in selling solar products and perform rural marketing
- Committed to advisory services, quality and after-sale service
- Owns a shop or business, preferably selling electrical items or other related products
- Has capacity to invest in stock (minimum of 20 lanterns) and serve a retailer network
- Has technical knowledge, or capacity to engage a technician (full time/part time)
- Is willing to sell to recommended retailer and to recommended end-user prices

Distribution of pico systems seems to be easier to streamline than distribution of larger solar systems that need to be customized. The latter are usually ordered on demand because they are more costly and do not sell as often or quickly. Larger distributors may keep a few in stock but smaller distributors wait until the order is set and clients have paid (most probably) at least a 50% deposit. These high value products/services require more face-to-face marketing and engagement as well as access to a technically competent and qualified installer/technician to ensure it is safe.

Main distributors work closely with their suppliers and the manufacturers to estimate sales, manage orders and feedback. Because of the delays during customs clearing and costs involved orders are made in bulk for a few months or a year to ensure enough supply. However, this means high risk for local suppliers and the manufacturers due to inventory cost.

4.4 Training

Many solar projects have success with including training of rural bank/micro-finance staff, distributors, retailers, installers, technicians, sales agents and credit officers in how to implement a solar project with a particular type of client. Others also develop training and operational manuals for implementers to refer to, after their training. Some of the training is specific to the product while some training is related to marketing, sales or general business skills and know-how development. Each firm has its own training programme. A large company like *Deng* has more training programs; short courses, three-day courses and one week courses on how to install and repair solar products. They train installers and those interested in solar know-how. There may be an opportunity to connect *Deng* with existing repairers to provide training programs or training manuals for OPV products. Some installers source talent directly from engineering colleges and provide additional training. These efforts help combat the dearth of trained installers as the electricians are called in to install systems they do not understand or know enough about.

Technicians in local markets typically repair and maintain electronics, cell phones, televisions and other appliances. Most of them do not have the formal education but they are willing to disassemble the products and find out how they work. When asked, the technicians in two local markets said they were willing to try repair of solar products. More of them had encountered solar products before. However, it took them longer to be able to repair these, because they first had to understand the technology and its layout. Another obstacle for repair was the unavailability of tools as repairers count on our local markets for work materials such as *Ogbogbloshie*. All the technicians asked in this investigation have learned by doing (self-taught) but will welcome a training program that could build their knowledge and capability on how to install solar products. They represent a potential source for talent that can be tapped into for maintenance and repair of OPV products. Hence, overall, our findings suggest that are capacity to develop a downstream maintenance and repair service market.

4.5 After sale service and support

This part of the value chain is one of the Achilles Heel of solar adoption in Ghana. Most distributors and projects focus on getting the products to people but have limited technical support available nearby and limited access to replacement parts such as batteries or small components. Sometimes it takes months to get a replacement or component, because the supplier is far away or distributors do not keep much stock in order to reduce risk. Similarly, even though some solar PV distributors have well established rural networks, they are ultimately located in the major cities, and are therefore unable to offer strong distribution logistics and networks to ensure consistent product availability. This results in unreliable product presence and lack of availability at the relevant point of purchase.

Lack of after-sales service and warranty discourages further sales and word of mouth recommendation to other clients and thus, weakens the potential for solar adoption by the people who need it most.

4.6 Conclusion

To date, the majority of the solar installation has been funded by the state or development agencies, and are done through tender for off-grid rural electrification. At present the Ghanaian market responds to the opportunities created by favourable policies, significantly increasing electricity tariffs and a changing of lifestyle to modernity.

The main activity in the space is within import, sales, distribution and system integration, and the kind of actors ranges from “briefcase entrepreneurs” with very limited knowhow to well established companies who have been in the business for a prolonged period and with deep understanding of their market and their products. Important private sector players operating in the market are: Deng, Wilkins Engineering, Burro Brand, Barefoot Solar, Greenlight Planet, PAYGO, Persistent Energy Partners Ghana (PEG), Starlight Solar, Dutch & Co, Atlas Business & Energy Systems, Aquasaline, Lumentech, Mascot, Mono Eco Green Energy, Novai, Power World, Toyola and T&G services. A wide range of products are available from retailers in Accra.

Distribution and after-sale service are identified as Achilles heels especially for the rural market. The lack of service and warranty discourages further sales and word of mouth recommendation to other clients and thus, weakens the potential for solar adoption by the people who need it most. Distribution of pico systems seems to be easier to streamline than distribution of larger solar systems that need to be customized. The latter are usually ordered on demand because they are more costly and do not sell as often or quickly. Another challenge in the market is low and costly importation force orders to be made in bulk for months to a year to ensure supply. This means high risk for local suppliers and the manufacturer due to inventory costs.

Many of the larger players rely on projects financed by the state or development agencies to stay afloat, in addition to wealthy urban dwellers or companies. There is also need to wean away from development funding to drive the market growth, and in the private sector, there is a significant number of players who are interested in this. They are all relatively small and regard the market as small but growing slowly. Many regard the West African market as the target to increase the economies of scale.

5. Openings for OPV on the Ghanaian market

This chapter illuminates the potential users' perception of solar energy in general and also their perception of specific solar products. The mapped perceptions are subsequently utilized to describe market opportunities, to outline recommendation on how to introduce OPV on the marked and to give examples of OPV products/applications that will be meaningful in the market.

The methodology used is vendor observations and case demonstration, see table 5.1. Vendor observations were applied to distinguish who the users of solar products are, to examine what solar products they are using and why they are using them. The approach comprises street observations and semi-structured focus group discussions with stakeholders. The stakeholders were represented by a convenient sample of willing persons. The study was conducted with three classes of people in the Ghanaian society: lower class, middle class and higher class. This was done in order to assess the perceptions of different groups of people with different purchasing abilities. The case demonstration was performed in order to map the potential customers' perception of given solar products. Three specific PV products (examples) were included in two versions made of respectively conventional Si solar cells and OPV. This was done in focus groups based on recruitment from the street and from students enrolled at Ashesi University.

Table 5.1: Overview of methodology used and key findings

Method	Rationale	Approach	Key stakeholder
Vendor observations	To distinguish who the users of solar products are and examine what solar products they are using and why they are using them	Street observations and some interviews (semi-focus groups)	Convenient sample of the willing
OPV demonstration case studies	To test the effectiveness, durability and ease of use of OPV in these three scenarios to be able to understand the nature of OPV and potential for local use	Focus groups	Recruited from street and also on Ashesi campus

5.1 The need for solar energy and portable power

Socioeconomic drivers have pushed solar energy into the market. Key examples of this are the electricity crisis and changing of lifestyles. The pressure on the national electricity generation and distribution agencies to recoup costs will increase pressure on consumers through high tariffs in the continued future. Electricity currently costs approximately four times more than it did before the crisis started in 2012. Consequently, the public is acclimatizing to the concept of renewable energy. People are suddenly realizing that they may have to diversify their energy sources and are exploring solar energy as one option and this despite the many attempts to implement solar energy done over the past years. For this reasons Accra retailers stock a variety of solar products: panels, lanterns, radios, fan, chargers etc., see Appendix xx.

Furthermore, many Ghanaians are returning home with different lifestyles and expectations. The demand for electrical goods and electricity has increased exponentially as a result. People are attempting to establish new firms, especially in the service sector (a major economic sector in Ghana), that is growing with restaurants, bars and so forth. There is a lot of demand and has been driving alternative energy.

Similarly, another demand-driven factor is the architecture. People are copying buildings from colder climates, especially glass houses or buildings, and this also drives up the demand for energy to keep the inside spaces cool. Due to poor architectural decisions in new building, the appliances as air-conditioners require a lot of energy, often beyond what a solar system can provide. Hence, owners will evaluate solar options, abandon it and go for a diesel generator. Another major stumbling block for solar energy in this segment is the high up-front cost characterized by sized systems for households and small businesses.

The research revealed that the market most conveniently is divided into two opposing target segments: the “Madina segment” representing the low-income consumers and the “East Legon” segment representing the high income segment. The Madina segment comprises the typical inhabitant of the town of Madina who see solar power as efficient for their needs because of their low power usage but they do not have enough disposable income to try it. The East Legon segment takes its name after a sparsely populated Accra suburb populated and occupied mainly by high-income groups and foreigners. This segment show very little interest in solar energy as they consider it insufficient for their high power usage (large, fully air-conditioned houses.) and do not have an awareness of solar cells as a means for portable power.

Based on these observations the strategy for entering the Ghanaian market should therefore be focused on making small scaled and portable solar products affordable to the Madina segment and on making the East Legon segment aware of that solar energy can do more for them than powering their high-demanding appliances:

- *Move the Madina segment to a position where they find solar power as affordable*
This means developing affordable products serving the Madina segment’s obvious need for charging portable applications as cell phones, radios, lanterns and power banks. Such products have to be low cost and/or have to provide economic benefits that justify their cost. This means competing with existing solar products for charging market on cost and benefits for the user.
- *Move the East-Legon segment to a position where see the benefits of small-scaled solar applications*
This means introducing low-demanding application that can cut the top of the household’s electricity bill and can make life easier/more comfortable for the individuals. Products for the homes could be off-grid sprinkler systems, security systems, exterior LED lights etc., and products for the individuals could be charging devices for portable electronics. Addressing this market means developing new meaningful applications for high-end users, and to compete on the market for portable power by increased user-friendliness and customer appeal, but also on cost.

The strategy is outlined in Figure 5.1.

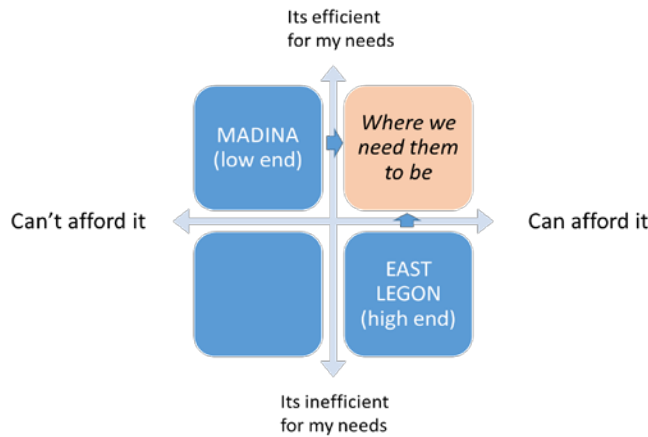

Figure 5.1: Proposed strategies for mitigating the two market segment' perception of solar energy

The investigations showed also that the general perception of solar power is that it is high cost and last for ever. Introduction of OPV on the market means that we have to work on this general perception so that the potential users realize that the economic value of the product relates to a trade-off between cost and operational life, see figure 5.2. Or in other words: is about whether or not the service provided over the life length of the product is worth its cost? Or illustrated by batteries for a portable radio: the cost of a solar powered battery charger plus the cost of rechargeable batteries should be compared with the cost of buying primary batteries for the radio, say every six week, over a period corresponding to the operational life of the charger, say three years. Or to develop comparative cost schedule for the cost of ownership over 10 years for a conventional solar installation lasting for the entire period and an OPV installation for which the OPV module is replaced three times over the period.

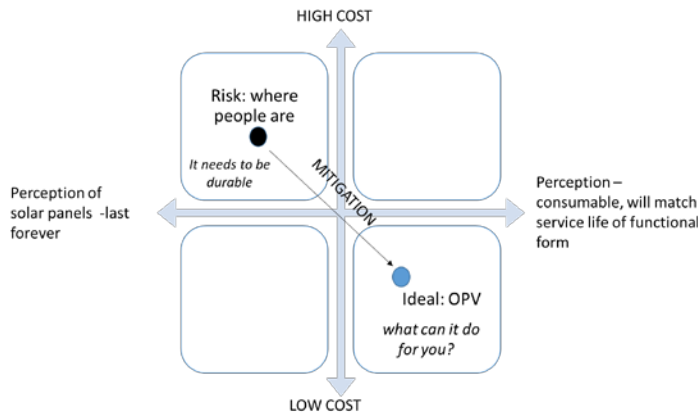

Figure 5.2: Proposed strategy for mitigating the general perception of solar cells as something expensive that lasts for ever.

Mitigation measures for counterbalancing the general perception of solar products for being costly and lasting for ever is needed. This could be to keep a sharp focus on the short term benefits, and to focus on “value for money”, i.e. the added values of the light weight and flexible outline of OPV as compared to the more rigid²⁴ and heavier conventional solar products.

²⁴ Conventional solar products are made from rigid silicon solar cells, rigid thin-film cells or flexible thin-film cells. The flexible thin-film are always far less flexible than OPV.

5.2 Perception of products made of OPV

The perception of products made of OPV was made by case comparison. A focus group comprised of first year students²⁵ at Ashesi University was presented to photos representing three different cases; solar cells integrated in a roofing system, a solar lantern and a solar cell-phone charger. Each case was presented in two versions: one based on conventional silicon solar cells and one based on OPV. The group was asked to comment upon photo in a structured process. The outcome of the discussions is summarized below and in table 5.2.

Roofing systems

The research identified that low income Ghanaians usually do not own their homes but live in rented accommodation. Many indicated that they would prefer the OPV version for the roof of their homes because it would be cheaper and easy to install and remove when they relocate because of its material nature. Similarly, the middle class respondents did not use solar panels but were aware of solar systems. They complained about the increasing prices of electricity and fuel, and about inconvenience of using a fuel generator. They indicated that they primarily need electricity to power the light bulbs in their homes and charge electronic devices (such as phones), which are very important for their business and other activities.

Lanterns

Regarding lamps, the research discovered that most of the participants were not familiar with lamps powered by a solar panel via a rechargeable battery. They were more familiar with battery lamps charged directly from the grid. Consequently, it was somewhat difficult for them to make the comparisons between a lamp charged via conventional solar cells and OPV. Respondents expressed interest in the lamps almost purely based on the fact that the lamps were seen as a tool to reduce the electricity bill. However, the predominant response was that the participants would not be significantly affected if they did not own the organic lamp. It should be noted that all respondents have access to grid electricity.

Phone chargers

The majority of the people asked could identify the need for solar powered mobile-phone chargers because mobile-phone use is common across all income levels. When comparing the inorganic cell phone charger²⁶ to the organic cell phone charger²⁷, most participants opted for the inorganic (silicon solar cells) charger because they found the aesthetics of the inorganic to be significantly more attractive: “genuine”, higher in quality and flexible. However, once it was explained that the OPV strip could be bent to fit a curved shape, preferences shifted. A small portion of people interviewed said they preferred the organic mobile-phone charger.

After finalizing the review of the cases, the participants were asked to recommend points of improvement for the products presented on the photos. The improvement points are listed in table 5.3.

²⁵ Demographics: 10 males and 3 females, 11 Ghanaians and 2 non-Ghanaians, all attending a course in innovation

²⁶ Normad 30 from Goal Zero, retail price USD 250

²⁷ HeLi-on from InfinityPV, retail price USD 105

Table 5.2: The focus group's response to various solar products

	RIGID SI SOLAR PANELS		MECHANICALLY FLEXIBLE OPV			
	pros	cons	pros	cons		
ROOFING			Stronger More durable High efficiency	Not user-friendly Lacking aesthetics Rigid No customizable	Tailorable to customer Aesthetic qualities	Less efficient
LANTHERN			Better design Bright lights	Limited in design Mechanically weak		
PHONE CHARGER			Durable More efficient	Heavy Too cumbersome	Light	Can easily tear Low efficiency

Table 5.3: The focus group's recommended improvements of the products presented for them

	RIGID Si SOLAR PANEL	MECHANICALLY FLEXIBLE OPV
ROOFING	Design them in brick roofing style or formats Make it multi-purpose Make it detachable	
LANTERN	Increased flexibility	Sturdier shapes; Photovoltaic cells placed outside, not inside, the lamp (moot point because the cells are not Is versus the lamp lamp not inside, the lamp (mthe light)); Wrap a normal lamp with the OPV foil to make it more efficient; Make it more stable to be placed.
MOBILE CHARGER		Make the foil shorter
GENERAL		Find ways to harness more energy by using the trapped heat.

Comment: no evaluation are done on the technical feasibility of the suggested point of improvements

5.3 OPV product ideas for the Ghanaian market

During the work ideas for OPV products for Ghana was generated, and these are listed below. The list should not be regarded as complete but should be regarded as a starting point for a structured process dedicated to identify new ideas and develop the most feasible products. Such a structured process should bear in mind the general impression build here saying that people are interested in cheaper solar products, but high quality (proven and perceived) and attractiveness is also perquisite for reaching the market.

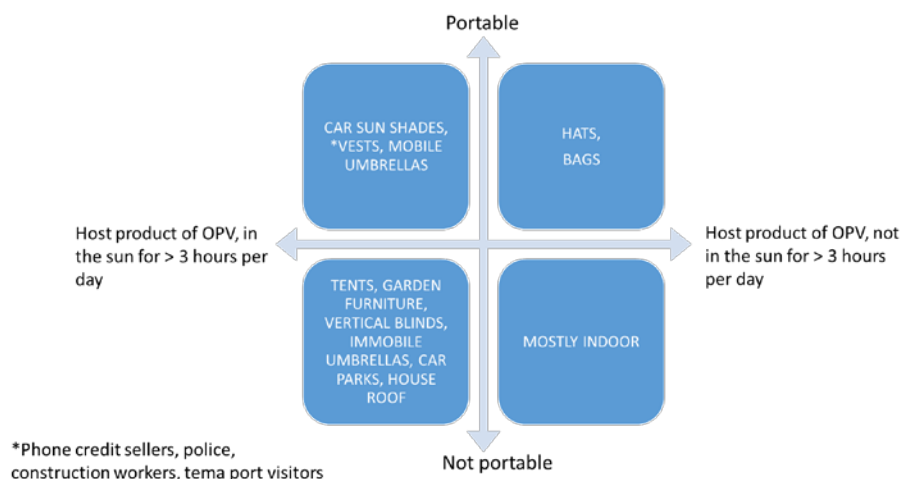

Figure 5.3: Systematic search for host, i.e. products into which it is meaningful to integrate solar cells.

The structured process for product identification could be start from the systematics developed in this investigation and presented in figure 5.3. The systematics starts with identification of hosts (products into

which the solar module could be integrated) followed by a grouping of the hosts according to length of their exposure to the sun under normal use and according to their portability or not. The most “powerful” hosts are to be found on the left side of the diagram’s vertical axis – powerful because they allow for more charging time or alternatively because modules with lower power output, i.e. smaller in physical size, can be used.

The first observation the researchers made for the Madina segment was how the majority of the people in the trade market (Madina segment) attempt to shield themselves from the intensity of the sun using large parasols. The market women’s mobile umbrellas typically shield those selling consumables on the streets like Fan Milk and Coca Cola products. The obvious opportunities in this segment are solar power for charging radios, cell phone and external batteries/power banks, and also for providing light and thus open for extended selling times in the evening. For this segment, OPV can for example be developed into a system that could be easily being thrown on a typical roof of market shed during the day. The same principle could be applied also to tailors who work through the night. This would reduce their cost of using lights at night.

Suggested products/functions for which OPV potentially can make a difference are (listed randomly and without any consideration of the technical feasibility):

Battery charging

Tradesmen (mechanics, masons, carpenter) and salesmen who work outside (street hawkers, mobile credit vendors who wear reflector vests) would benefit from easily deplorable/spreadable OPV foils, to charge a battery. They can quickly spread their solar foils to charge a battery that they would use later. When they leave their place of work they can quickly roll up the foils to put in their pockets or bags and transport them to their destination. Alternatively could the OPV foil be integrated in security vests.

Windshield shades for cars

Another application of the OPV foils may include use on wind shields to prevent sunlight from heating up car interiors, while charging a battery or keeping the charge. That energy could be redirected to power a battery and small fans in the car.

Small portable fans

Small personal and portable cooling systems are a need; portable fans to carry with your small fans to keep flies away from food. Market women could for example wear wide brim hats that protect them from the sun and serve as host for the OPV module.

Incubators

Incubators for premature babies in hospitals could be considered, as well as clothing to keep babies warm or cool.

DC appliances

DC appliances and solar energy is a good match, but the availability of DC appliances is limited. Many off-grid households therefore opt for grid power when the grid comes nearby, and invest in AC appliances even though they consume more power in situation where the user are forced to go off-grid due to power outages.

Others

Other uses of OPV touched upon during the investigation are on farming sheds, directly on walls and in office blinds.

5.4 Conclusion

The openings in the Ghanaian market for OPV are as means for providing off-grid charging of small electric appliances and for cutting the top of the high electricity bill of wealthy households. An obvious and general need for people in Ghana is to shield from the intense sun. If meaningful OPV applications can be integrated devices giving shade, it might also be an interesting market.

The need for off-grid charging is huge especially in the low- and medium-income segments of the market. This segment counts many people working outside all day without access to grid electricity. Providing portable power to this group will among others open for prolonged uptime for their cell phones, the amusement and education provided by radios, cooling via small fans, and access to light after sunset and thus longer opening hours for small businesses and increased security. Products for this market have to be affordable for the target group. This means the products have to undercut the retail prices of the Chinese products that already have captured a strong position on the market. The products also have to signal durability, as even the cheapest products will be a large investment for this segment. Portability and low weight are also important factors as products for this market have to be carried to and from the workplace/market place on a daily basis. Products for this segments could be small handy USB charges and products as rollable or foldable tarpelines/carpets, parasols, umbrellas, lanterns, security vests for road workers, the vest provided by the cell phone companies to the sellers of mobile credit all with integrated OPV and thus charging capacity.

The products for the high-income segments are mobile chargers for electronic devices and off-grid power supplies for low-demand household appliances. The charges have to give something to the user that the present charges on the do not. This could be better functionality, easier to carry with you, easier to use, more appealing design and competitive cost. The products for the households have to be meaningful for the user's daily life and must have the ability to cut the top of the electricity bill. Possible products could be sprinkler systems, external lightening and security systems.

OPV integrated in the vertical blinds often seen in office buildings might also be a viable product, because it both serves dual function and addresses the professional market.

6. Local production and knowledge platform

This chapter reviews the Ghanaian knowledge platform relevant for carrying domestic assembly of OPV-powered products from sourced components, and also the knowledge platform needed for carrying a possible future domestic production of OPV modules. The methodology applied to review the knowledge platform is described in table 6.1 together with the key findings.

Table 6.1: Overview of methodology used and key findings

Method	Rationale	Target Stakeholder	Key Findings
Site visits to relevant manufacturing	To understand the experiences of solar manufacturing in Ghana and gain insights for potential manufacturing of OPV components or related systems	Tradeworks (manufacturing solar panels) and RLG, GN Electronics (assembling electronics)	These companies are building the market as the initial players and have started collaborating in ways that will define the economics of the market. E.g. they can impact the market by setting prices through restriction of supply or overproducing to block imports by driving down prices etc.
Visits to universities, discussions and review of scientific production		KNUST University of Ghana Kumasi Polytechnic	The knowledge generation at the universities are generally highly academic and not focused on supporting production

Ghanaian companies holding knowhow in assembly of silicon solar products and panels count *Wilkins Engineering, Deng, Tradeworks and SPS – Strategic Power Solutions*. Deng and Wilkins Engineering have previously been manufacturing solar panels and lanterns; however, they were unable to compete with lower prices of imported products from China and suspended manufacturing. These two companies targeted the small-scale market due to limited capacity. Wilkins Engineering was running this business from 2004 to 2008.

At present Tradeworks and Strategic Power Solutions (SPS) are heading for assembling solar panels based on imported silicon solar cells. Both companies were visited as a part of this study. Strategic Power Solution demonstrated successful operation of all stages in the process from solar cells to panels, i.e. stringing and lay out of the cells, lamination with back sheet and glass, framing and contacting of the panel and finally quality control by flash IV test, but it is unclear whether or not the plant is in normal production yet. During the visit they mentioned assembly of solar lamps as an interesting business for them. Tradeworks stated that they have advanced plans to put up a local assembly plant, but the precise status is unknown.

6.1 Local design and assembly of OPV product

The basic components in pico-scale OPV products for off-grid applications is an electronic circuit consisting of the solar module, a charge controller, a battery and the electrical component to be powered, e.g. the pay load. Relevant pay loads are USB chargers, LED light bulb etc. The circuitry once designed and manufactured is then to be integrated in a suitable casing or host which can be a lantern, a roof plate, a cell phone charger etc. Design of the electronic circuitry rests on an understanding of the OPV module as an electronic component and on basic skill in power electronics, whereas the rest hinges on skills in design, product development and the manufacturing methods relevant for the casing/host.

The circuitry, i.e. the OPV module, the charge controller and the battery, have to be sized for the power required by the payload and the lengths of its use, for example reading light for 3 hours a day. The basic electronic principle that rules the design of the circuitry is generic and independent of its size. Circuitry of a given size (nominal power) can thus be regarded as a standard component suited for integration into more products requiring the same nominal power. This standard component can be customized to actual products by adjusting the solar module's physical shape but not its area as this is determined for the nominal power. This allows the standard component to be customised so it fits into the casing/host.

When the circuitry is designed and assembled the remaining process concerns design and manufacturing of the host/casing and assembly of the product from the two basic parts; the circuitry and the casing/host. This is a matter of product development and design skills; design for functionality, design for assembly and design for giving the product the right signals, linked with the relevant manufacturing processes for the host/casing. None of these disciplines are OPV specific and relevant expertise is most probably found somewhere in Ghana; in the manufacturing industry, by the ones producing the host today, in Ghana's emerging design business and in the educational system.

Assembly of electronics

The critical step in local manufacturing of OPV products is cost-effective and reliable assembly of the electronic circuitry. Two potential companies for the assembly task, *RLG Electronics and Group Nduom Electronics* (GN Electronics), were interviewed as a part of this study. RLG Electronics specialises in the assembly of computers, tablets, laptops and cell phones in Ghana, and Group NDUOM Electronics in assembly of digital boxes (turns TV signal from analogue to digital) and televisions.

Both companies have experience in workflow management, deployable logistics and supply chain insights and a pool of qualified technicians. They have built assembly plants with a process where the assemblers put together electronics (soldering etc.) according to pictures placed in front of them at the assembly table. These companies also have equipment for electronics testing and product testing (drop tests etc.). The assembly of the circuitry for OPV products should not be more complicated than the assembly already mastered by the two companies.

Local assembly of generic circuitry for OPV products can be based on knock-down kit containing all parts needed for the assembly, i.e. OPV modules and all electronic components needed, or semi-knock-down kits holding some of the components, for example everything except the OPV modules. The alternative is to source each family of components individually. The best option depends on the sourced volumes, on the technical experience of the assembler and the assemblers sourcing strength.

Value chain

The value chain for local assembly of OPV products will comprise the following steps:

1. Sourcing, design and assembly of the electronic circuitry (OPV modules, charge controller, battery and pay load)
2. Design and manufacturing of the host/casing
3. Integration of circuitry into the host/casing
4. Finalisation of the product (testing, packaging etc.)
5. Distribution, marketing & sales
6. After sales service & support.

The knowledge base and infrastructure for establishing local manufacturing of OPV products from sourced components should cover all these steps. The best option for covering the downstream part of the value chain (step 5 and 6) is to team up with local partners that already have strong sales organisations, but also have sufficient technical knowledge of solar cells in general to understand the characteristics of OPV. Most preferably this should be one partner who can supply all the non-OPV specific knowledge needed and who can serve as key business partner. This could be Deng or Wilkins.

The upstream steps in the value chain could be covered by teaming up with RLG Electronic or Noduum Electronics or alternatively Margins Group, who is specialist in printed electronics, for step 1, and Deng, Wilkins, Tradeworks or Strategic Power Solutions for step 3 and 4. The industrial knowledge base supplied by these partners should be complemented by expertise from Ghana's manufacturing industry (injection moulding is present and will be relevant), from the emerging design business and universities having design on the scheme. The general knowledge of solar energy available at KNUST and Kumasi Polytechnics will also be useful in this aspect.

6.2 Local processing of OPV modules

Building an industry on processing of the OPV modules requires strong competences in solution processing technologies (printing and coating) and an understanding of the OPV module's delicate chemistry and physics. For the latter theme – the understanding - the Ghanaian platform is limited.

Margins Group holds relevant competences and has machinery for roll-to-roll flexographic printing of electronics. This serves as an adequate platform for developing domestic production of OPV modules, but more printing methods (screen printing, slot-die coating) have to be added to their setup for being able to manufacture complete OPV modules. Margin Group's expertise seems high and they are regarded as fully qualified for processing OPV modules provided transfer of proven production technology.

The Danish OPV processing technology is ready for such a transfer to a qualified receiver. Furthermore the commercial availability of feed materials for the processing (printing inks, printing substrates, encapsulation foils) is acceptable and is also expected to further improve of the next years. Dedicated roll-to-roll machinery is also commercially available. An example of a roll-to-roll machine on which all processing steps, except lamination and contacting, can be done is shown in figure 6.1. Despite all elements needed is there, local production of OPV modules should not be put on the agenda before the market is ready and the demand is sufficient for carrying the production volumes associated with roll-to-roll processing.

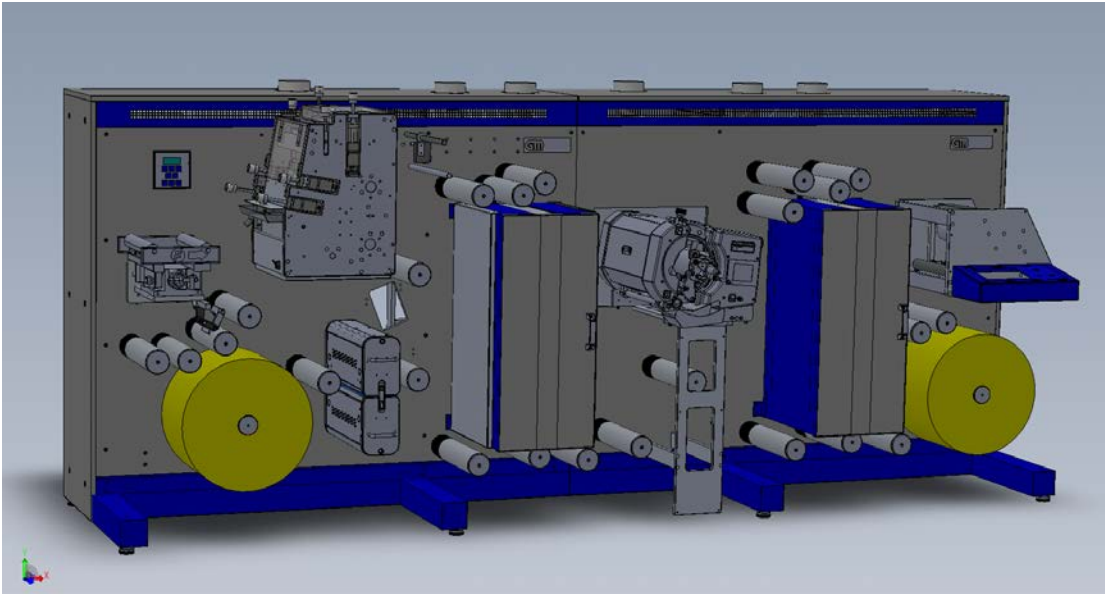

Figure 6.1: Example of full scale roll-to-roll machinery that can handle most of the processes needed for manufacturing of OPV modules. Supplier: Grafisk Maskinfabrik.

Building local manufacturing of OPV modules with lasting competitiveness requires R&D capacity at local universities. OPV is a fast evolving technology, i.e. what is best practice today will for sure not be best practice tomorrow. Today there are groups at *Kwame Nkrumah University of Science and Technology (KNUST)* and *University of Ghana* working with the OPV technology and PV technologies in general, but their focus is highly scientific and the solar cell concepts studied do not always have industrial relevance. For supporting an upcoming manufacturing industry technology development especially in the field for relevant production technology (roll-to-roll solution processing) is needed. So is also the focus on solar cell concepts that are industrially applicable.

Another task needed, that is best lifted by universities, is the close following of the international R&D progress in the field in order to advice industry about upcoming new concepts and new knowledge that could be beneficiary for the competitiveness of their commercial product. Building strong and industrially relevant university knowledge requires time, and actions that motivate the universities to change their focus from science to technology development should be taken as early as possible. This could for example be done by seeking finance for bench-scaled machinery that mimics full scale roll-to-roll processing for OPV processing, see figure 6.2, and also for the training of university personnel in the processing of OPV on such machines. This will give the universities a unique opportunity to focus their R&D on OPV onto industrial relevant issues, and also for educating attractive candidates to the industry, not only a future OPV business but businesses working with advanced printing and coating technology, as Margins.



Figure 6.2: Bench-scaled machinery that mimics full-scale roll-to-roll processing: a roll-to-roll printer/coater from Grafisk Maskinfabrik (top) and a roll coater from FOM Technologies (bottom).

6.3 Conclusion

The infrastructure, knowhow and the value chain needed for establishing a Ghanaian business on assembly of OPV-powered products are available locally. Electronic components and OPV modules should be sourced from abroad.

The required knowhow in electronic circuitry design is to be found in the cross-field between industry already active in assembly of electronics (RLG Electronics, Group Nduom Electronics) and at universities/university colleges having basic electronics engineering on their scheme (KNUST, Ashesi University, Kumasi Polytechnics, and presumable more). Margins Group, a specialist in printed electronics, is also expected to have sound competence in this field. The two companies, RLG Electronics and Group Nduom Electronics, are both running industrial assembly of advanced electronics today, and their infrastructure and knowhow should be suited for also performing industrial assembly of circuitry for OPV products. Sourcing of electronic component via these companies might be interesting as prices for components are highly volume dependent. The companies Deng, Wilkins, Tradeworks and Strategic Power Solutions have all expertise in assembly of solar products. Tradework and Strategic Power Solutions are in the process of establishing assembly of solar panels locally based on silicon solar cells imported from China, whereas Deng and Wilkins have been assembling solar panels and lanterns previously. The technical

expertise and infrastructure of these companies will for sure be of benefit for an upcoming industry on assembly of OPV products.

The competences and infrastructure listed above have to be complemented by non-PV specific expertise from Ghana's manufacturing industry (injection moulding is present and will be relevant), from the emerging Ghanaian design business and universities having design, product development and engineering on the scheme. The technical expertise should be matched with expertise in distribution, marketing and sales, and this is most adequately done by teaming up with partners already strong in this part of the value chain, for example Deng or Wilkins.

Building a local business on processing of the OPV module itself is far more demanding and has to be built on a sound platform of knowledge covering solution processing and the understanding of the chemistry and physics of OPV. Margins Group is strong in printed electronic, i.e. solution processing of a related product. The company is regarded as highly qualified for running a production of OPV modules, and they have also shown interest in doing so. However, establishing a domestic production should await a local build-up of the market. OPV is a fast developing technology, and building a strong business in this field requires also strong competences in R&D. KNUST and University of Ghana have scientific activities in the field of OPV. For being able to support a future business the present focus should be turned in the direction of technology development and should be enlarged in scope to also cover production technology.

APPENDIX 1: POLICY

A1.1 List of stakeholders consulted

Organization	Directorate	Persons contacted	Contact email
Policy makers			
Ministry of Power	Directorate for RE	Wisdom Ahiataku-Togobo	wtogobo@gmail.com
Energy Commission	Renewable Energy Division	Mr. Julius Nkansah-Nyarko	
	Strategic Planning and Policy Division (SPPD)	Dr. Joseph Essandoh-Yeddu	jeyeddu@hotmail.com
	SE4All Secretariat	Ms. Paula Edze	pedze@energycom.gov.gh
	Former Board member	Prof. F. Akuffo	
Ministry of Env., Sci, Tech. and Innov. (MESTI)	Ag. Dep. Dir., Science, Technology and Innovation	Ms. Adelaide Asante	adelaidegh@yahoo.co.uk
Academic and research institutions			
KNUST	TEC	Mr. Ato Quansah	david.ato.quansah@gmail.com
KNUST	TEC	Mr. Joseph Akowuah	akowuahjoe@yahoo.co.uk
Kumasi Polytechnic	CREK	Mr. Edem Bensah	edem.bensah@gmail.com
NGOs, CBOs and others			
CEESD	Co-Director	Mr. Edward Antwi	
New Energy	Director	Mr. Amadu Mahama	mahama.amadu@gmail.com
Solar businesses			
Aeko Solar	Staff	Isaac Edwin	edwinadjei@gmail.com

A1.2 Beginning of implementation of the 200,000 solar rooftop programme

Page 38 Website: www.ghananationtimes.com.gh Monday, February 9, 2016 The Ghanaian Times



ENERGY COMMISSION

PRESS RELEASE

ENERGY COMMISSION TO BEGIN IMPLEMENTATION OF CAPITAL SUBSIDY FOR ROOFTOP SOLAR PV PROGRAMME

The Ministry of Power, through the Energy Commission, is implementing a Rooftop Solar Photovoltaic (PV) Programme in the country. The programme is in fulfillment of the President's Rooftop Solar PV initiative announced in 2015. As part of the preparatory activities, the Energy Commission has implemented some pilot projects to ascertain the technical feasibility and viability of the initiative. As at today, a number of rooftop solar systems of different capacities have been installed under different scenarios including the use of Net Meters which will enable the beneficiaries to sell electricity generated from solar systems back to the distribution companies who will credit the beneficiary with the supply.

In order to kick-start the actual implementation of the programme, the Energy Commission has been tasked to facilitate the installation of 20,000 rooftop solar PV systems in residential facilities (homes) under a Capital Subsidy Scheme in 2016.

Under the programme, a capital subsidy will be given to beneficiaries in two forms, as either:

- cash payment for solar panels component of the solar PV system; or
- the supply of actual solar panels after the beneficiary has purchased and installed the requisite Balance of System (BoS) components such as inverter, batteries, charge controllers, etc.

The maximum capacity of solar panels that will be granted each beneficiary under the programme shall be up to 500Watts.

A number of commercial banks have expressed interest in providing loan facilities to interested beneficiaries in respect of the procurement of BoS components for the solar PV systems of their choice.

Programme Objective

The primary objective of the programme is to provide 200MW peak load relief on the national grid through solar PV technology in the medium term.

Who can be a Beneficiary?

- Residential Facilities (Homes)

Qualification Criteria

Prospective beneficiaries shall satisfy the following conditions:

- Change all lamps in their facility to LED lamps;
- Be willing to purchase BoS Components;
- Install only deep cycle batteries designed for solar PV systems;
- Ensure that BoS meet the minimum Standards set by Ghana Standards Authority (GSA); and
- Use only solar PV installers licensed by the Energy Commission for all the installation works.

How to become a Beneficiary

- Pick an Application Form from the Office of the Energy Commission or its website, fill and submit it;
- Receive approval of application from the Energy Commission;
- Obtain a list of accredited solar vendors where BoS must be purchased from the Energy Commission;
- Purchase the requisite BoS components (batteries, charge controllers, inverter, changeover switch and wires) from an accredited solar vendor of your choice;
- Invite Energy Commission field officers to come and inspect the installation of the BoS; and
- Obtain from the Energy Commission solar panels to be coupled to the installed BoS or a cash refund for the cost of the solar panels already purchased and installed, if the criteria is met.

Application Form

Application Forms may be downloaded at www.energycom.gov.gh

Completed Application Forms should be submitted at the Office of the Energy Commission or addressed to:

The Programme Director
National Rooftop Solar Programme
Energy Commission
PMB, Ministries Post Office
Accra.

A1.3 Questionnaire for Stakeholder Interviews

DRAFT BASELINE SURVEY QUESTIONNAIRE TO IDENTIFY POLICIES AND SUPPORT SCHEMES THAT CAN FACILITATE OR JEOPARDIZE SOLAR OPV PRODUCTS IN GHANA

Background: Solar Organic Photovoltaic products are a type of solar PV technology that are cheaper, have low production costs, but low efficiency (approximately 4-5%) and often applied at the small scale level, such as for solar lanterns, mobile phone chargers and stand-alone home systems.

NB: Questions with * are targeted at policy makers, i.e. ministries and their departments / agencies. If any interviewees falling outside of this scope is willing to provide an answer, he/she is free to do so.

There is popular opinion that solar may become the most developed RE technology in Ghana, do you agree with this assertion? Any reasons why you do or do not agree?

Enabling framework and market actors

Solar lanterns, chargers for mobile phones and solar home systems (SHS) are increasingly sold at the market in Ghana. Do you know of any specific support schemes (donor, NGO or government) for increased diffusion of products for these three markets, – such as tax exemptions, finance schemes, guaranties, awareness campaigns, quality control.

Do you know of any trade regulations that hinders import of these technologies?

Do you know of any trade regulations that hinders assembly of small scale solar applications mentioned above?

Do you know which companies are market leaders on the marketing for these three products and do you know which countries they import from?

Can you list any Ghanaian companies, who import, sell, install or rent out lanterns, mobile phone chargers or SHS?

Local production, assembly and industry development

What are the prospects of solar component assembly and manufacturing business in Ghana?

Do you know of any specific plans in the past or in the future of local product assembly in Ghana?

In case of such Ghanaian assembly plants – were they targeting the small scale market, such as solar lanterns, battery chargers, the market for Solar PV or the market for large grid connected solar PV

Theories of innovation would prescribe that new technologies such as PV develop in a niche for small scale products and that the technology gradually develop to broader and more competitive markets. In this context this would imply that there is a linkage between the PV markets for solar lanterns, solar chargers, solar home system and large grid-connected systems. On a scale of 1 to 5 (5 being the most likely); I would be grateful if you could respond to the following questions?

- Can such a linkage be established on a time scale --- small moving towards large

1 2 3 4 5

- Are the large grid connected installations politically acceptable in Ghana, because people and policy makers have experience with and trust in PV, or is it seen as a new grid technology

1 2 3 4 5

- Are large grid connected installations in Ghana building on knowledge in existing enterprises dealing with small scale solar PV (importers, installers, maintenance companies) or are these installations mainly based on knowledge and expertise from abroad

Local knowledge 1 2 3 4 5

- To which extent are large grid connected installations in Ghana

- using expertise from Ghanaian universities

1 2 3 4 5

- using Ghanaian engineering expertise

1 2 3 4 5

- procuring material through Ghanaian importers

1 2 3 4 5

- using Ghanaian skilled personnel with knowledge of PV

1 2 3 4 5

- How and to which extent are companies, knowledge and products related to large grid-connected installations in Ghana providing positive (spill-over) effects to existing enterprises dealing with small scale solar PV? Such effects could e.g. be cheaper products (panels, converters), training of personnel, exchange of personnel, demonstration effects, or linkage to international suppliers

Technology

There are different types of solar PV technology: e.g. amorphous silicon, monocrystalline and polycrystalline modules. Do you foresee any particular type becoming a preferred technology in Ghana, especially for small-scale applications?

What solar technologies for small scale applications do you anticipate to have a higher prospect in Ghana?

Are you aware if policy/planning documents support new PV technologies that are still under development?

Organic PV

Are you aware of Solar Organic Photovoltaic technology?

On a scale of 1 to 5 (5 being the highest); How strongly do you foresee OPV being accepted by policy makers in Ghana if it met all international solar PV technology standards?

1 2 3 4 5

Has any manufacturer or researcher ever discussed this technology with you or your institution?

Could there be possible reasons why it **would not** be accepted even if it met all international solar PV technology standards?

On a scale of 1 to 5 (5 being the highest); Do you foresee the use of OPV for small scale applications aiding in its acceptance and patronage across Ghana. Please state your reasons.

1 2 3 4 5

*As a policy maker, have you or your ministry/agency ever had any intentions to restrict solar products to some specific technology (ies)? If yes, please indicate the technology (ies)

On a scale of 1 to 5 (5 being the most likely); is it likely, trade regulation **could** restrict this technology in the future?

1 2 3 4 5

Barriers or enablers for OPV

*Would the Ghanaian government accept a manufacturer who intends to set up a solar OPV technology manufacturing plant in Ghana?

What incentives are in place to encourage new ideas and technology like solar OPV?

*If a solar OPV plant were to be set up, what components of the manufacturing plant are likely to be tax exempt? What other tax exemptions/incentives are available?

What are the challenges you foresee for solar component assembly and manufacturing businesses in Ghana?

Do you foresee the government ever restricting the export of solar OPV if it were manufactured in Ghana?

What are the possible policy challenges you anticipate with regards to solar OPV development in Ghana general?

Any further comments?

APPENDIX 2: MARKET

A2.1 Market prices for solar lanterns

This Appendix provides July 2013 retail prices for a number of solar lighting products in Senegal. The first table include products meeting Lighting Africa's minimum quality standards. The second table include products that have not been tested or which are not meeting the standards. The table is included to illustrate the price level in West Africa, but the reader should consider that prices may have been reduced significantly in the last three years (Dalberg, 2013a)²⁸

Products marketed in Senegal which are meeting Lighting Africa's Minimum Quality Standards

Name of product	Retail price F CFA (€s)	City/ Village	Area (urban/rural)
Met Lighting Africa's Minimum Quality Standards			
Greenlight Plane (Sun King – ECO)	7,500 (€11.43)		Rural
Greenlight Plane (Sun King – SOLO)	10,500 (€16.01)		Rural
Greenlight Plane (Sun King – PRO)	24,500 (€ 37.35)		Rural
d.light S10	7,000 (€10.67)	Dakar	Urban
	6,500 (€9.91)	Fatick	Rural
d.light S250	20,000 (€30.49)	Dakar	Urban
	19,500 (€29.73)	Fatick	Rural
SCHNEIDER ELECTRIC	30,000 (€45.73)	Dakar	Urban
IVT	30,000 (€45.73)	Dakar	Urban
STECA 220 -240 V	25,000 (€38.11)	Dakar	Urban
Little Sun <i>(distribution had not yet started at the time of writing)</i>	7,500 to 8,000 (€11.43 - €12.20)		Urban and rural
Sundaya U1, 2, 3 and 4 <i>(distribution had not yet started at the time of writing)</i>	40,000 - 130,000 (€60.98 - €198.18)	Dakar	Urban

²⁸ Exchange rate as of 19.04.2016 : 1 EUR is 1.18 USD: <https://www.oanda.com/currency/converter/>

Products not meeting Lighting Africa's minimum quality standards

Name of product	Retail price F CFA (€s)	City/ Village	Area (urban/rural)
<i>Have not been tested, or did not meet LA's Minimum Quality Standards</i>			
PHLIGHT	5,000 (€7.62)	Fatick	Semi-Urban
Maxima 3W (Chinese product, looks very much like d.light S250/ S300)	2,500/5,000 (€3.81 / €7.62)	Dakar	Urban
	5,000 (€7.62)	Fatick	Semi-Urban
LED IBRIGHT	2,500 (€3.81)	Kaolack	Semi-urban
Britex	1,500/2,500 (€2.29 / €3.81)	Dakar	Urban
POOKIN	5,000 (€7.62)	Dakar	Urban
SOLARTEX	300/700/1,000 (€0.46/1.07/1.52)	Dakar	Urban
SKYPEN	1,500 (€2.29)	Dakar	Urban
NOKIA (Chinese)	2,000 (€3.05)	Dakar	Urban
LEU LIGHTS	2,300 (€3.51)	Dakar	Urban
Longlife	1,000/3,000 (€1.52 / 4.57)	Fatick	Semi-urban
Unknown Chinese brand	900/1,000/1,500 (€1.37/1.52/2.29)	Dakar	Urban
	3,000 (€4.57)	Fatick	Semi-urban
KANY	1,000/1,500 (€1.52/2.29)	Kaolack	Semi urban
Orbiteck	2,000 (€3.05)	Kaolack	Semi urban

A2.1 Lighting Africa quality verified products

This appendix is copied from Appendix 2 of the Off-grid solar market trends report 2016 published by Lighting Africa (Orlandi et al., 2016)

SOLAR HOME SYSTEM KITS

FOSERA GROUP

LSHS 9800+Lamps+Panel



MOBISOL

Mobisol Family SHS 19" TV



OMNIVOLTAIC POWER CO. LTD.

OvCamp HS1-144_LB2244



OvCamp Solar Home System



SOLARWORKS!

Solar Home System



ZIMPERTEC

Litio Solar Home System Kit



PICO SOLAR PRODUCTS

ANJI DASOL SOLAR ENERGY SCIENCE & TECHNOLOGY CO.

SSL200



AZURI TECHNOLOGIES LTD.

Indigo Duo Solar Home System



BAREFOOT POWER LTD.

Barefoot Firefly/
Firefly Mobile



GO 250/GO 255



Connect 600



D.LIGHT DESIGN

A1



S20



D20



S100



S2



S300



PICO SOLAR PRODUCTS (continued)

FOSERA GROUP

Pico Solar Home System
Family – PSHS 2800, PSHS
7000 and others



FREEPLAY ENERGY

Solar Energy Centre



FUTURA

Energy Station Plus



GREENLIGHT PLANET INC

Sun King Home Eco



Sun King Pro 2



Sun King Home Plus



Sun King Pro All Night



Sun King Home



Sun King Solo



Sun King Mobile



GS YUASA INTERNATIONAL LTD.

AKARi



Mini Moshi-Moshi



INDIA IMPEX SUNLITE

JS30-MOB



JUA ENERGY

Home Mate



M-KOPA SOLAR

M-KOPA 3



MIBAWA SUPPLIERS LTD.

Mibawa Solarpack 3



MICROMARK

Compact LED Solar Light



PICO SOLAR PRODUCTS (continued)

NIWA NEXT ENERGY PRODUCTS LTD.

Home Run 400 X3



Multi 300 XL



MSS-Modular Solar Systems (Family)



Office 200 X2



Multi 100 Plus



Uno 50



NURU ENERGY

NL3-800



NL3-1000/Laerdal Light



OFF-GRID SOLUTIONS B.V.

WakaWaka



OMNIVOLTAIC POWER CO. LTD.

MB2-090



MB2-380



MB2-200



OvCamp HS1-36_LB1122



MB2-290



OvPilot X



ORB ENERGY

Solectric 10



Solectric 15



Solectric 30



PANASONIC CORPORATION

Solar Lantern



RENEWIT SOLAR LIMITED

Solarway G1 Solar Power Lantern/
Solarway G1 Lantern



Solar Homework Light



SCHNEIDER ELECTRIC

Mobiya TS120S/Awango TS120



PICO SOLAR PRODUCTS (continued)

SINOWARE TECHNOLOGY CO. LIMITED

Solar Lamp



SOLARLAND (WUXI) ELECTRONIC POWER TECHNOLOGY LTD.

Solar Power Pack 5.0



SOLARWORKS!

Solar Kit Lithium



ZHEJIANG HOLLEY

Solar Lantern



A2.3 Photo Album showing products available from retailers in Accra



Seller/Supplier: Ama Assanwaa
 Product/Service: Solar lights and phone charging solar panel



Seller/Supplier: Mohammed (Royal Tech)
 Product/Service: Rechargeable solar fans



Seller/Supplier: GeoPat
 Product/Service: Rechargeable lamp with solar panel. Comes with torch and three light bulbs. Has usb port for charging phones



Seller/Supplier: Okyere
 Location: Achimota
 Product/Service: Solar power bank. Can be charged with electricity also. Has two ports for charging devices.



Seller/Supplier: Suntech Energy
 Location: Accra
 Product/Service: Supply and install solar panels



Seller/Supplier: Ben
 Location: Ako Adjei Estates
 Product/Service: Sells solar generators. Can power TV, laptop and appliances less than 100 watts



Seller/Supplier: Alfred Akil Location: Accra
 Product/Service: Sells solar rechargeable lamps. Comes with LED lights and solar panel. Has usb port



Seller/Supplier: Bright Location: Achimota
 Product/Service: Sells solar panels, solar batteries and street lights

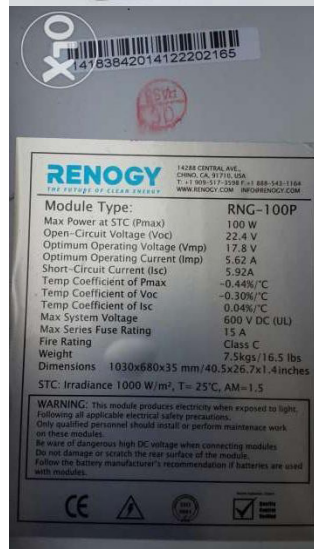

Seller/Supplier: Sowah Location: Adenta
 Product/Service: Sells a 100 watts solar panel, Solar charge controller and digital meter



Seller/Supplier: Rahaman Location: Lartebiokoshie
 Product/Service: Sells solar lighting system. Comes with a radio. Has pen drive and SD card slots and usb port for charging phones



Seller/Supplier: Nii Adu Mensah Location: Accra
 Product/Service: Sells solar panels and solar batteries



Seller/Supplier: Datavoice Network Systems Location: Accra
 Product/Service: Supplies and installs monocrystalline and polycrystalline panels of all sizes and capacity for homes and offices



Seller/Supplier: Eric Location: Accra
 Product/Service: Sells solar lanterns with solar mobile chargers. Has SOS Flashing and emergency signal, Solar Energy and adapter 5v for power generations, usb port to charge phones and other digital products. Can be used as flashlight without lamp shade stretching



Seller/Supplier: Jay Location: Kwashieman
 Product/Service: Sells GD light solar power system for LCD TV, fans, laptop, phones and all your home appliances



Seller/Supplier: Naa Location: Dansoman
 Product/Service: Sells Solar LED light with remote control
 Features: 25 pieces high brightness SMD LED bulbs (Long Lifespan of 50000 hours of light, Rechargeable for more than 200 times)
 Battery Types: Lead Acid battery with 3.7V 800mA, Duration time is more than 7 hours, 3 modes of lighting, Very portable, 1W/ 6V Solar panel, can be used to charge smartphones



Seller/Supplier: Prince Isaac Location: Tema
 Product/Service: Sells 25 pieces LED solar lamp
 Features: Lifespan of 50000 hours of light. Rechargeable for more than 200 times.
 Battery type: Lead Acid battery with 3.7V 800 mA. Duration time: more than 7 hours, 3 modes of lighting, very portable, 1W/ 6V Solar panel. Can be used to charge smartphones.



Seller/Supplier: My Glory in Him Ltd. Location: Nungua
 Product/Service: Sells 23000mAh solar panel power bank for smartphones and laptops
 Brand: Poweradd™
 Features: Battery Type: Li-Polymer battery cells with solar panel
 Capacity: 23000mAh/85Wh
 Input: 15-20V 1.2A
 Output: 1 x USB 5V 2.1A + 1 x DC12V/16V/19V 3A
 Solar Charger: 15V 230mA (max)
 Size: 8.85x4.92x0.86 inches
 Weight: 1.44 lbs
 Package included: 1 x Poweradd Apollo Pro 23000mAh Solar Panel Power Bank, 3 x Mobile Phone Connectors, 10 x Note-book Connectors, 1 x Micro USB Cable, 1 x DC Cable, 1 x AC Adapter, 1 x User Manual



OLX



Seller/Supplier: Jay Location: Accra
 Product/Service: Sells solar power bank for charging phones. Has two ports. Capacity: 5000 mAh



Seller/Supplier: Derrick (Wilkins) Location: North Kaneshie
 Product/Service: Sunking solar lamp. Can be used to charge phones



OLX

Seller/Supplier: Solomon Location: Burma
 Product/Service: Sells solar panel with light, USB port which charges all mobile phones and portable mp3 players



OLX



OLX

Seller/Supplier: Prince Location: Accra
 Product/Service: Sells solar lantern. Come with a solar panel, remote control and digital display to show runtime

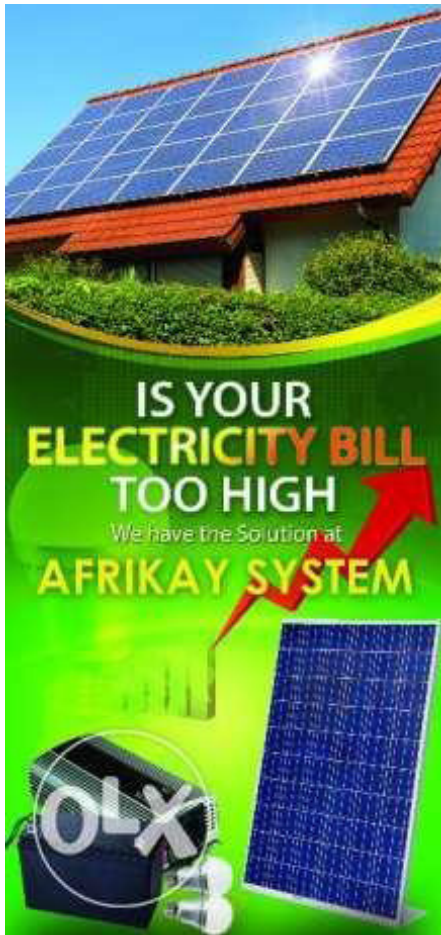

Seller/Supplier: Afrikay System Location: Adenta
 Product/Service: Sells and install solar panels and other solar products



Seller/Supplier: Shakur
 Product/Service: Sells Power Plus solar lanterns
 220/240V AC charger
 12V DC car charger



Seller/Supplier: Collins Location: Accra
 Product/Service: Sells solar power inverter (2000w)
 Features: Deep cycle gel solar batteries, PV solar panels, Intelligent battery chargers, Solar charge controllers



Seller/Supplier: Godwin Ahuble (Powerlink Solar Installations)
 Location: Accra
 Product/Service: Installs solar power inverters



Seller/Supplier: Vision Energy
 Location: Accra Newton
 Product/Service: Sells a variety of solar powered products which include: Solar panels, solar fridge, solar air conditioner